

2026 national curriculum tests

Key stage 1

Mathematics

Paper 2: reasoning

First name	
Middle name	
Last name	

Total marks	
-------------	--



Ajay



Amy



Ben



Kemi



Sam



Sita

Practice question

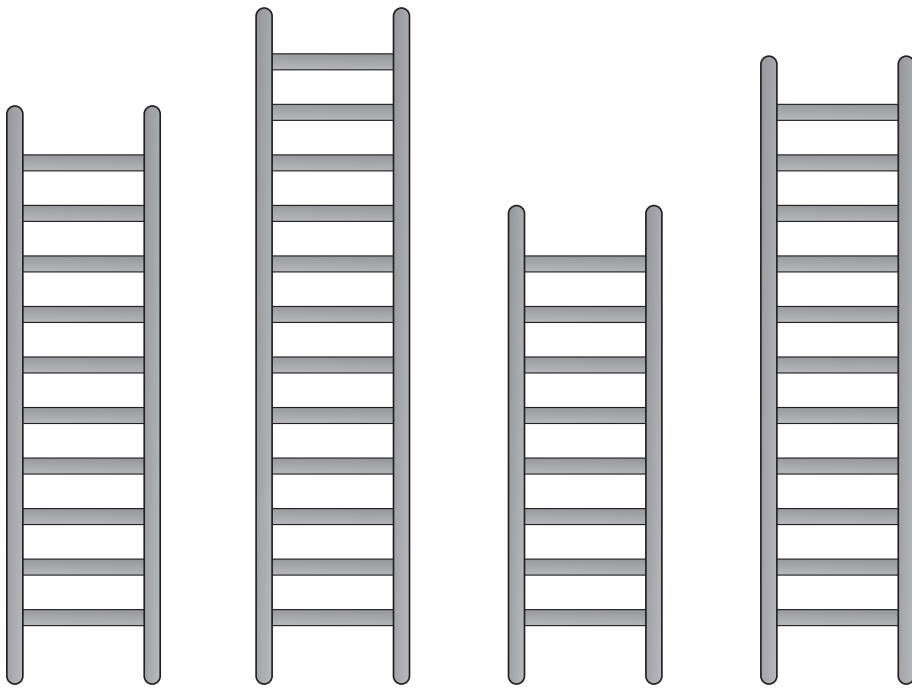

1

55 56 57 58 59...



1 mark

2

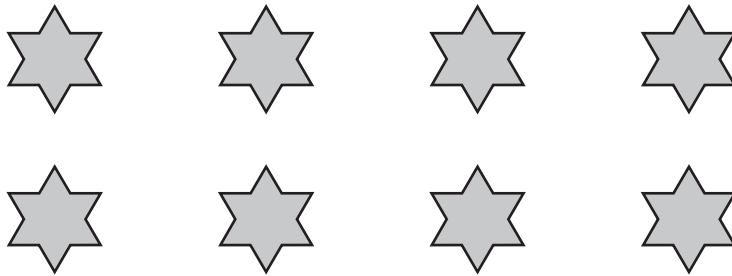

1 mark

3

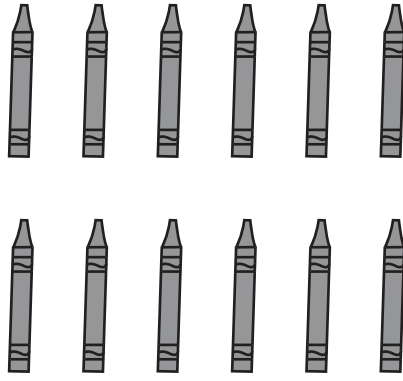

$$6 - 2$$

$$6 \times 2$$

$$6 \div 2$$

$$6 + 2$$



1 mark

4

86

20



1 mark

5

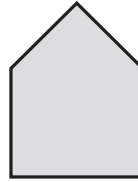
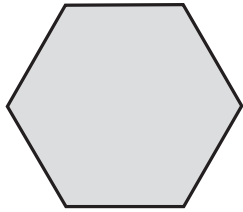
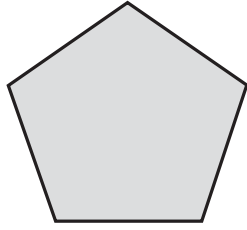

1 mark

6

The numbers on these teddy bears are ordered from the smallest to the largest.

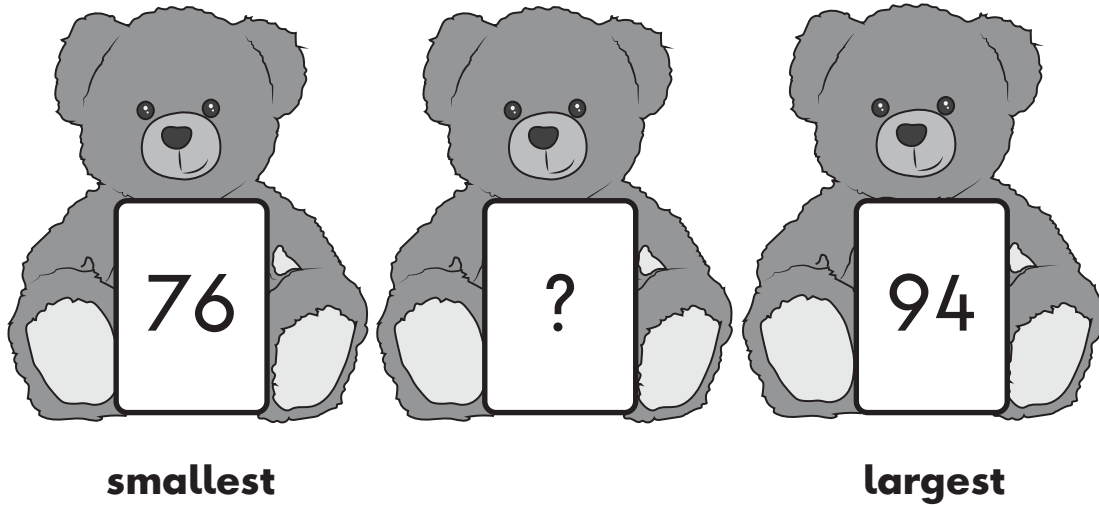

Tick the correct number for the middle teddy bear.

67

49

83

96



1 mark

7

This is **one** stick.



This is a bundle of **ten** sticks.



How many sticks are there in the box below?

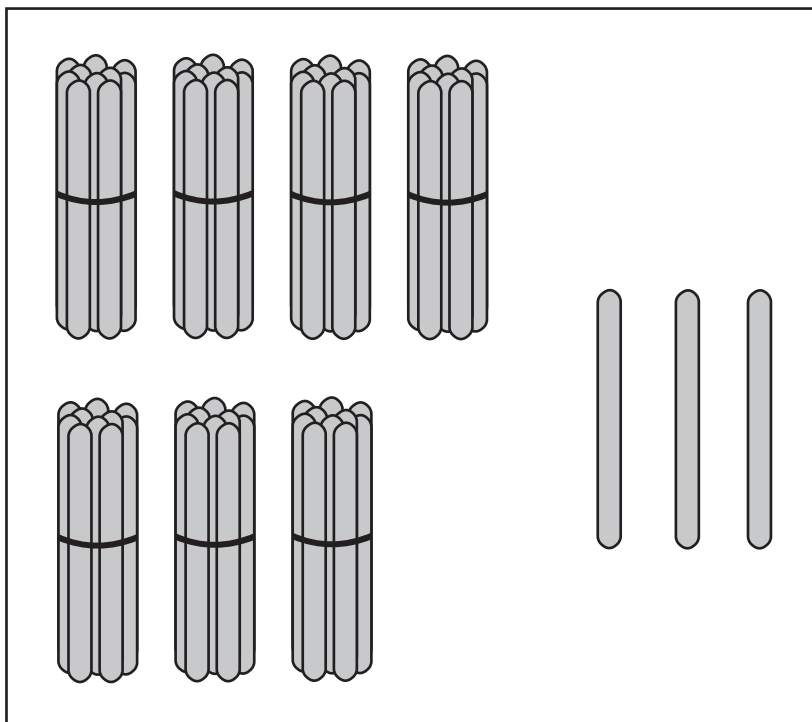

sticks



1 mark

8 Ben wants to buy a robot.

It costs **£20**

He has **£11**

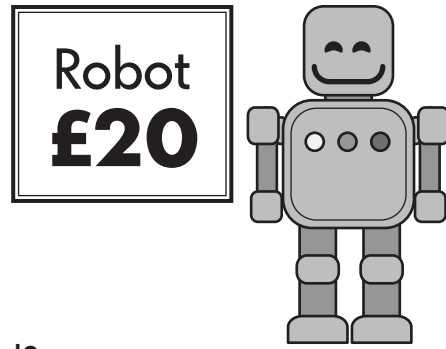

How much **more** money does he need?

£

1 mark

9 Circle **all** the numbers that have **6 tens**.

16 26 61 56 66

1 mark

10

Compare the lengths of pencils using these signs.

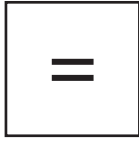
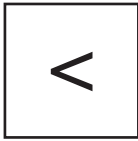
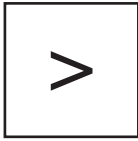

Pencil A



Pencil B



Pencil C



Write the correct sign in each box.

length of Pencil A

length of Pencil B

length of Pencil A

length of Pencil C



1 mark

11 A bag has **100g** of pasta.

Sam uses **70g**.



How much pasta is **left** in the bag?

g

1 mark

12 Draw lines to order these times from the shortest to the longest.

6 weeks

6 years

6 months

6 days

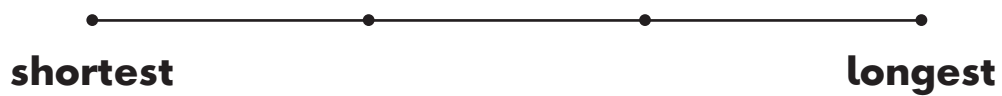

1 mark

13

Amy collects stickers.

She buys a pack of **5** stickers each week.

How many stickers does Amy buy in **4** weeks?

Circle your answer.



5 10 15 20 25

1 mark

14

Draw line B on the grid so that it is **double** the length of line A.

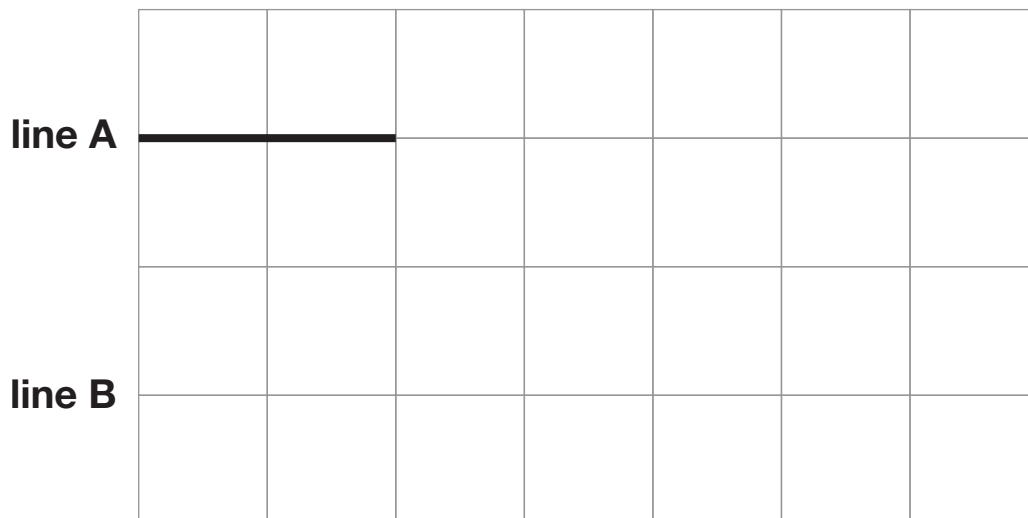

1 mark

15

This diagram shows different ways to make the **total 100**

Complete the diagram.

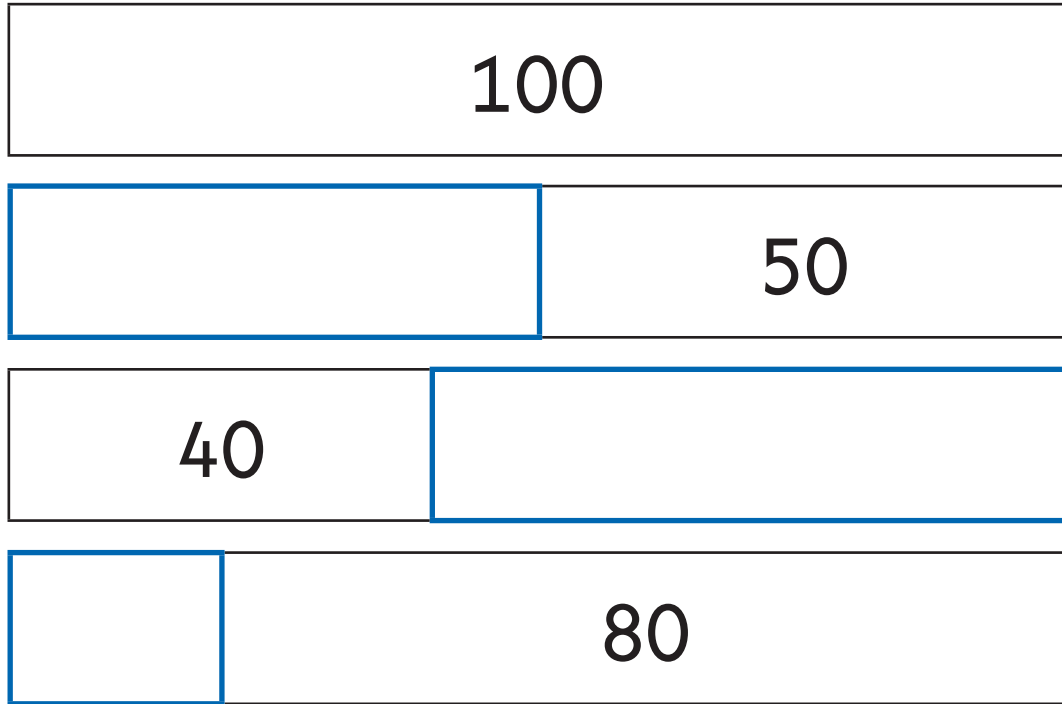

1 mark

16Tick **odd** or **even** next to each number.

One is done for you.

	odd	even
11	<input checked="" type="checkbox"/>	<input type="checkbox"/>
48	<input type="checkbox"/>	<input type="checkbox"/>
72	<input type="checkbox"/>	<input type="checkbox"/>
63	<input type="checkbox"/>	<input type="checkbox"/>



1 mark

17

How many **faces** does a triangular prism have?

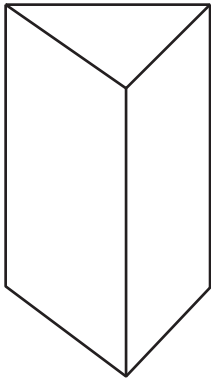

triangular prism

faces



1 mark

18

Kemi has **7** toy cars.

Sam has **3** toy cars.

Kemi



Sam

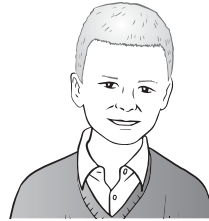

Kemi gives Sam some of her cars.



They now have the **same** number of cars.

How many cars did Kemi give Sam?

cars



1 mark

Weather	Number of days
 Snowy	
 Sunny	
 Rainy	/

How many sunny **and** rainy days were there **altogether**?

 days

1 mark

20

Here are three number cards.



Use the number cards to make two **different** calculations.

$$\square \times \square = \square$$

$$\square \div \square = \square$$



1 mark

21

This is an array of oranges.

Some of the oranges are hidden.

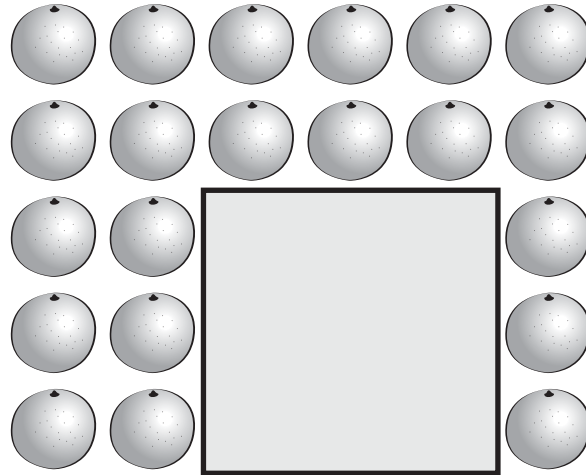

How many oranges are hidden?

oranges

1 mark

22

Here are some number cards.

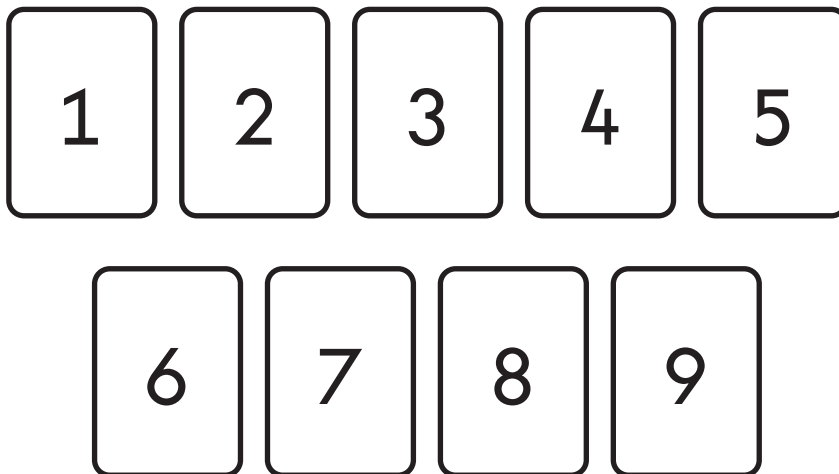

Use the number cards to make the calculation correct.

$$7 + \square + \square = 20$$

○
1 mark

Now use two **different** number cards to make the calculation correct.

$$7 + \square + \square = 20$$

○
1 mark

23

Sam has **two** coins.

The two coins are the **same**.

His coins **total** one of these amounts.

Circle **one**.

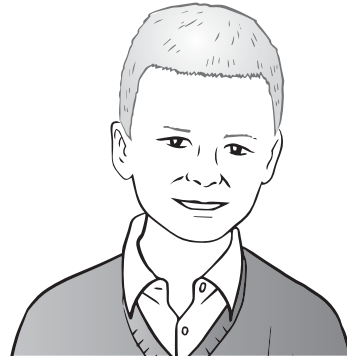

30p

35p

40p

45p



1 mark

24

This number line is divided into **equal** steps of 3

What number is the arrow pointing to?

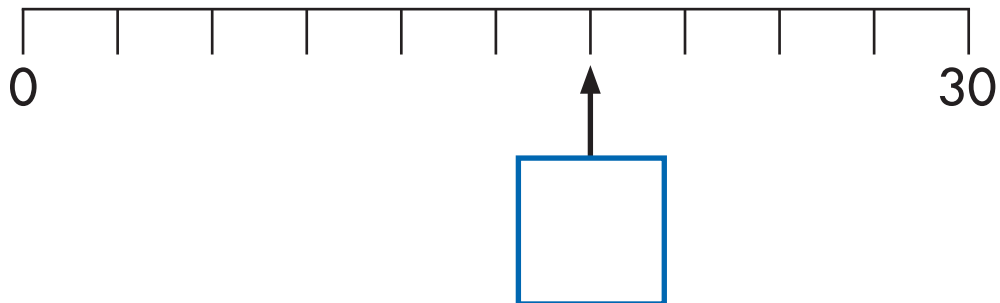

1 mark

25

Sita is building towers using cubes.

Each tower has **5** cubes.

Sita has **45** cubes.

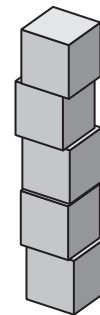

How many towers does she make?

towers

1 mark

26

A class has **20** sports balls altogether.

The block diagram shows how many there are of each type.

Draw the missing blocks to show how many netballs there are.

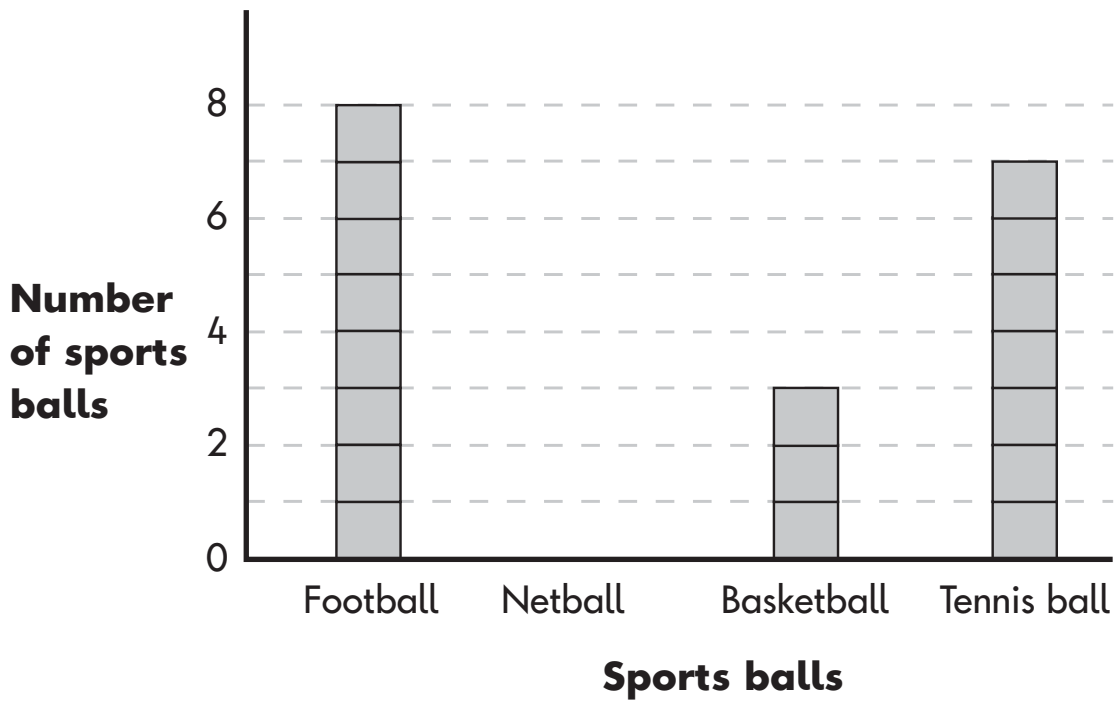

1 mark

27

Write four coins that **total 27p**.



1 mark

28

There are **6** boxes of crayons.

Each box has **5** crayons.

Ajay takes **16** crayons.

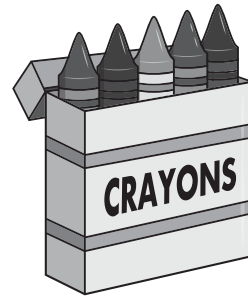

How many crayons are **left**?

Show
your
working

crayons

2 marks

29

Look at this card.

$$\frac{1}{2}$$

Tick a card below that shows the **same amount**.

$$\frac{3}{4} \quad \square$$

$$\frac{2}{4} \quad \square$$

$$\frac{1}{4} \quad \square$$

$$\frac{1}{3} \quad \square$$



1 mark

30

Kemi builds some towers with cubes.

The towers get bigger each time by the **same amount**.

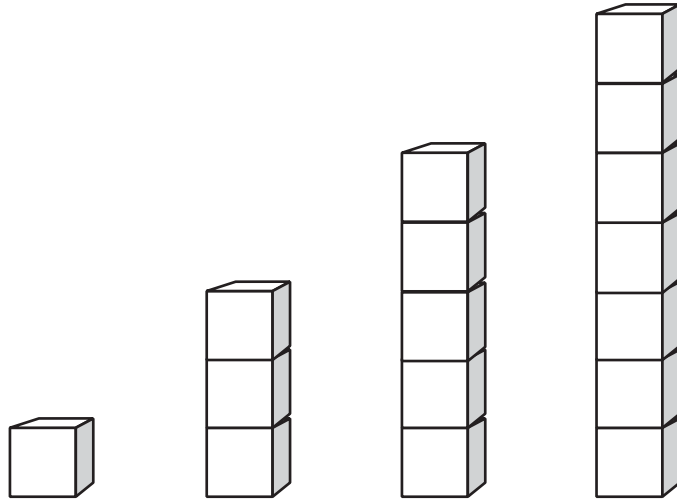

How many cubes will Kemi need for her **next** tower?

cubes



1 mark

31

Sam is baking cakes.

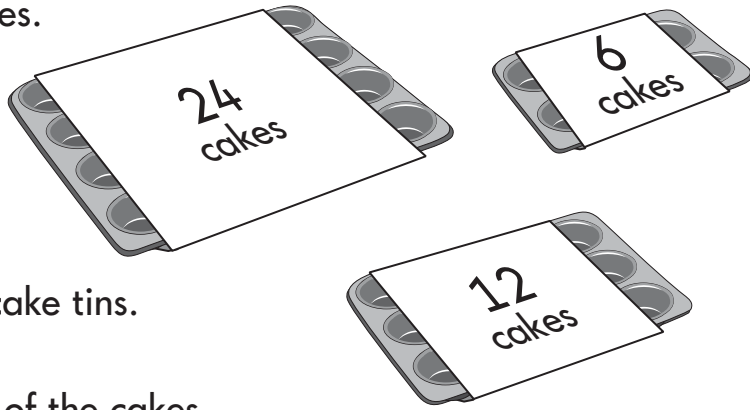

He fills **all** these cake tins.

His family eat **15** of the cakes.

How many cakes are **left**?

Show
your
working

cakes

2 marks

Team A	Team B
38	51

Team B has **more** points than Team A.

How many more?

Tick **one**.

27

17

23

13



1 mark

End of test



Standards
& Testing
Agency

Key stage 1 mathematics Paper 2: reasoning
Product code: STA/26/9008/e ISBN: 978-1-83507-459-6

For more copies

This document can be downloaded from www.ncportal.education.gov.uk during May 2026, or afterwards from www.gov.uk/government/collections/national-curriculum-assessments-past-test-materials.

© Crown copyright

The materials in this booklet are Crown copyright. You may re-use them (not including logos) free of charge in any format or medium in accordance with the terms of the Open Government Licence v3.0, which can be found on the National Archives website and accessed via the following link: www.nationalarchives.gov.uk/doc/open-government-licence.



If you have any queries regarding these test materials, please contact the national curriculum assessments helpline on 0300 303 3013 or email assessments@education.gov.uk.