



## **JADTEU AIRPORTABILITY INFORMATION AND DESIGN GUIDE**

# **GUIDELINES FOR INTERNAL AIR TRANSPORTABILITY OF VEHICLES AND EQUIPMENT IN UK MILITARY AIR TRANSPORT AIRCRAFT**

**ISSUE 18  
MAY 2026  
EXTERNAL USE**

**JOINT AIR DELIVERY TEST AND EVALUATION UNIT  
AIRPORTABILITY SECTION  
RAF BRIZE NORTON  
CARTERTON  
OXON OX18 3LX**

**THIS PUBLICATION IS REVIEWED ANNUALLY IN JULY AND UPDATED IN  
DECEMBER AS REQUIRED**

## CONTENTS

<a href="#">CHAPTER 1 .....</a>	<a href="#">GENERAL INFORMATION</a>
<a href="#">CHAPTER 2 .....</a>	<a href="#">PRINCIPLES OF RESTRAINT</a>
<a href="#">CHAPTER 3 .....</a>	<a href="#">EQUIPMENT DESIGN - CONSIDERATIONS</a>
<a href="#">MERLIN HC MK 4 DATA SHEET .....</a>	<a href="#">ANNEX A</a>
<a href="#">CHINOOK ALL MKS DATA SHEET .....</a>	<a href="#">ANNEX B1</a>
<a href="#">CHINOOK ALL MARKS CABIN BALLISTIC PROTECTION .....</a>	<a href="#">ANNEX B2</a>
<a href="#">CHINOOK ALL MARKS CABIN BALLISTIC PROTECTION .....</a>	<a href="#">ANNEX B3</a>
<a href="#">C-17A GLOBEMASTER DATA SHEET.....</a>	<a href="#">ANNEX C</a>
<a href="#">A400M DATA SHEET.....</a>	<a href="#">ANNEX D</a>

**Please read this manual carefully before clicking the link below to access the leaflets listed.**

## EVIDENCE FOR JADTEU AP ASSESSMENT

<a href="#">LEAFLET 1 .....</a>	<a href="#">GENERAL INFORMATION</a>
<a href="#">LEAFLET 2 .....</a>	<a href="#">VEHICLES WHEELED</a>
<a href="#">LEAFLET 3 .....</a>	<a href="#">VEHICLES TRACKED</a>
<a href="#">LEAFLET 4 .....</a>	<a href="#">TRAILERS</a>
<a href="#">LEAFLET 5 .....</a>	<a href="#">HELICOPTERS</a>
<a href="#">LEAFLET 6 .....</a>	<a href="#">GROUND SUPPORT EQUIPMENT</a>
<a href="#">LEAFLET 7 .....</a>	<a href="#">ISO CONTAINER, CABIN AND CONTAINERS</a>
<a href="#">LEAFLET 8 .....</a>	<a href="#">MARINE CRAFT</a>

**CHAPTER 1**  
**GENERAL INFORMATION**  
**CONTENTS**

Para		Page
1	CONSULT EARLY .....	4
2	COMPLIANCE .....	4
3	JSP 800 VOLUME 7 DEFENCE MOVEMENT AND TRANSPORT REGULATIONS - LOAD SAFETY REGULATIONS AND TIE DOWN SCHEMES - DIRECTIVE .....	4
4	TASKING JADTEU AIRPORTABILITY SECTION .....	5
5	AIRPORTABILITY TASK PROCESS .....	5
6	AIRCRAFT TYPES .....	5
7	CLEARANCES AND READY ACCESS .....	9
8	WEIGHT AND BALANCE .....	10
9	EQUIPMENT DATA (Information required when requesting airportability clearance) .....	10
10	CARGO RESTRAINT .....	11
11	AIRCRAFT LOADING METHODS .....	11
12	DRIVEN IN .....	11
13	WINCHED IN .....	12
14	PALLETISED LOADS .....	13
15	TIE DOWN SCHEMES/TIE DOWN NOTES .....	13
16	TIE DOWN NOTE (TDN) .....	13
17	TIE DOWN SCHEME (TDS) .....	14
18	DANGEROUS GOODS .....	16
19	PUBLICATIONS .....	16

Figures

Image 1 - C-17AGlobemaster .....	6
Image 2 - Loading Submarine Rescue Vehicle into a C-17A .....	6
Image 3 - C-17A Globemaster Cargo Hold .....	6
Image 4 - A400M .....	7
Image 5 - A400M Cargo Hold .....	7
Image 6 - Chinook HC Mk 6A .....	7
Image 7 - Chinook HC Mk 5 .....	8
Image 8 - Vehicle restrained inside Chinook HC Mk 6 .....	8
Image 9 - Merlin HC Mk 4 .....	8
Image 10 - Merlin HC Mk 4 winched into a C-17A Globemaster .....	9
Figure 1 - Minimum clearances and Ready access requirements .....	10
Figure 2 - C-17A - Loading a MAN SV .....	12
Figure 3 - Cabin on mobiliser wheels winched into a C-17A .....	12
Figure 4 - Palletised trolley - secured to air cargo pallet with an aircraft net .....	13
Figure 5 - Example of C-17A TDN .....	14
Figure 6 - Example of a C-17A TDS .....	15

## 1 CONSULT EARLY

The JADTEU Airportability Information and Design Guide is a publication from the JADTEU Airportability (AP) Section to aid organisations who have a requirement for cargo to be capable of being transported by air, internally in UK Military Air Transport aircraft. That is to be airportable. This publication will offer guidance for the design and development of cargo intended to be airportable. It is not definitive, it is advised that JADTEU AP Section should be consulted early in the design and development process. In addition to the Airportability Section in JADTEU, there are 4 other lead sections. These are Aerial Delivery, Parachute Test Team, Helicopter (for external under slung loads) and Training. Refer to the website for further information.

This guide is applicable only to equipment that is to be internally air transported and will be assessed by the JADTEU Airportability Section. For guidance from the other sections of JADTEU contact them directly or via the JADTEU Task Co-Ordinating Officer (Refer to Para 4).

## 2 COMPLIANCE

Def-Stan 00-003, Section 2, Para 10 (Design Guidance for Transportability of Equipment) specifies the requirements for loading, carriage and off-loading of equipment intended to be airportable internally in UK Military air transport aircraft.

The UK MOD has also agreed to comply with a number of NATO Standardisation Agreements (STANAG) for air transport and an Allied Tactical Publication (ATP). These are:

- 2.1 STANAG 7213 -Tactics, Techniques and Procedures for NATO Air Movements (Supercedes STANAG 3400 and 3548). This STANAG refers to ATP 3.3.4.1 as the standard to be complied with.
- 2.2 ATP 3.2.49.2.2 Technical Criteria for the Transport of Cargo Helicopters (Supersedes STANAG 3542).
- 2.3 ATP 3.3.4.1 - Tactics, Techniques and Procedures for NATO Air Movements (Chapter 7).

It is essential if you have identified a requirement for materiel to be airportable that you are aware of Def-Stan 00-003, the relevant STANAGS and the ATP and the equipment is designed and manufactured to be compliant with these standards. Therefore, equipment sponsors should ensure that the contracted equipment supplier provides a product that complies with Def-Stan 00-003 and STANAG 7213, and 3542 and ATP 3.3.4.1 Chapter 7.

Normally, JADTEU are tasked by DE&S Delivery Teams (DT), although we do accept tasking from other MOD and Government organisations. When a task is submitted the task applicant will be expected to provide technical data required for an airportability and engineering airworthiness assessment to be carried out. In order to achieve an airportability clearance the equipment has to be within the relevant aircraft limitations (dimensions, weight, floor loading, etc). It must also be proven to comply with Def-Stan 00-003 and must achieve a JADTEU engineering airworthiness clearance.

The JADTEU AP Hangar is equipped with Cargo Hold Mock-Ups (CHMU) of the C-17A, A400M, Chinook and Merlin. The majority of airportability clearance trials are carried out using these CHMUs.

A common problem encountered by JADTEU is that Equipment Sponsors have not considered airportability or sufficiently understood airportability during the appropriate stage of the equipment acquisition process. Therefore, when JADTEU are tasked it may be late in the acquisition process; this could result in expensive modifications. Also, contracts may be signed that do not include a requirement for the equipment to obtain JADTEU airportability clearance with no reference to compliance with Def-Stan 00-003. It should be noted that equipment could be airportable on civilian charter aircraft (in compliance with the Civil Aviation Authority) or other nation's military aircraft, but that does not automatically mean they are airportable on UK Military Air Transport aircraft (in compliance with the UK Military Aviation Authority); this capability can only be assessed and authorised by JADTEU.

## 3 JSP 800 VOLUME 7 DEFENCE MOVEMENT AND TRANSPORT REGULATIONS - LOAD SAFETY REGULATIONS AND TIE DOWN SCHEMES - DIRECTIVE

JSP 800 Volume 7 mandates that the DE&S DT introducing new or updated equipment have a Tie Down Scheme (TDS) developed to meet minimum standards of load restraint. A DT delivering new or modified equipment and vehicles into service should consult with JADTEU at the initial stages of the project, to understand the extent of movement data and TDS required and to ensure compliance with the KiD Support Solutions Envelope. The provision of a TDS is mandatory at the point when the vehicle enters service.

#### 4 TASKING JADTEU AIRPORTABILITY SECTION

The tasking procedure for JADTEU is outlined in Defence Instruction Notice 2025DIN04-024. Advice on how to task JADTEU is available from the JADTEU Task Co-ordination (TCO) Office. JADTEU is formally tasked by submitting a Task Initiation Form (TIF) to the TCO (accessed from the JADTEU Sharepoint Homepage).

#### 5 AIRPORTABILITY TASK PROCESS

On acceptance of a JADTEU TIF, the Airportability Task Process is:

- 5.1 AP Trials Management Officer (TMO) and Trials Engineering Officer (TEO) will be assigned to the task.
- 5.2 TMO contacts the Task Sponsor to arrange a Start Up Meeting (SUM).
- 5.3 SUM will require as a minimum, attendance by the Task Sponsor, but should also aim to include technical representatives from the equipment manufacturer.
- 5.4 The aim of the SUM is to begin the task process, briefing the Task Sponsor and manufacturer on our requirements and for the TMO and TEO to be briefed on the equipment. A SUM will normally be held on MS TEAMS, but can be face to face at JADTEU or could be offsite, at the manufacturers' site for instance.
- 5.5 The TMO and TEO will normally wish to view the equipment, details for this will be arranged at the SUM.
- 5.6 Sponsor must provide the TMO with data required for an airportability and engineering airworthiness assessment to be carried out.
- 5.7 When the TMO determines that all the necessary data has been supplied a loading assessment period will be agreed. Loading assessments will normally be carried out on the appropriate JADTEU CHMUs. Typically 5 working days are required per equipment on each aircraft type.
- 5.8 Loading assessment - The Sponsor provides the equipment in the condition that it will fly – at the correct weight, build standard and prepared for air transport.
- 5.9 Loading assessment - may require, Sponsor, manufacturer and suitably qualified and experienced operators present. The TMO will specify.
- 5.10 Airportability assessment carried out by the TMO and Engineering Airworthiness Assessment carried out by a JADTEU TEO. Loading and restraint schemes devised on the mock-ups.
- 5.11 Loading assessments may also be carried out on live static aircraft. This may take longer, depending on the availability of an aircraft.
- 5.12 Tie Down Schemes/Tie Down Notes and task report produced.
- 5.13 Task Sponsor acknowledges task report.
- 5.14 Tie Down Schemes/Tie Down Notes published in appropriate aircraft publications.

#### 6 AIRCRAFT TYPES

This Design Guide refers to the principal UK Military transport aircraft that JADTEU routinely authorise airportability clearances for. These are the:

- 6.1 C-17A - Globemaster.
- 6.2 Chinook (All marks).
- 6.3 Merlin HC Mk 4.
- 6.4 A400M.



Image 1 - C-17AGlobemaster



Image 2 - Loading Submarine Rescue Vehicle into a C-17A

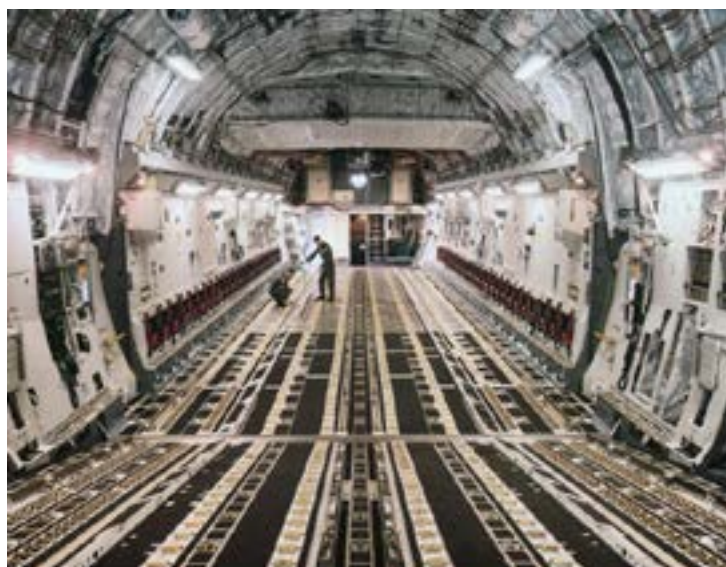

Image 3 - C-17A Globemaster Cargo Hold



Image 4 - A400M



Image 5 - A400M Cargo Hold



Image 6 - Chinook HC Mk 6A



Image 7 - Chinook HC Mk 5



Image 8 - Vehicle restrained inside Chinook HC Mk 6



Image 9 - Merlin HC Mk 4



Image 10 - Merlin HC Mk 4 winched into a C-17A Globemaster

## 7 CLEARANCES AND READY ACCESS

There are aircraft data sheets at Annexes A to D. These show basic information about the aircraft, and are intended as an aid only, JADTEU should always be consulted as there are many factors to consider. For example, although the data sheets show the internal dimensions these cannot be taken as the maximum size of the load, we must also consider a minimum clearance to the airframe and components, ready access, how the load behaves when traversing the ramp (overhang, axle spacing etc), attachment of restraint chains and many other factors. Each aircraft has its own limitations for floor loading intensity, axle weights and compartment loading, these must all be assessed.

In UK Military transport aircraft and helicopters there is to be a minimum all round clearance, between the aircraft structure (above floor level) of 1 in. during loading and 3 in. during flight (See Figure 1). In addition, ready access must also be provided to:

- 7.1 The crew compartment and crew stations.
- 7.2 Cabin consumer facilities.
- 7.3 Emergency controls.
- 7.4 Safety and survival equipment.
- 7.5 Emergency exits (as appropriate to the number of passengers carried and the route to be flown).
- 7.6 Dangerous goods, when carried.

To meet the requirements listed above a ready access 'clearway' must be provided from one end of the aircraft to the other as defined in Figure 1. The minimum ready access requirement is one of the following:

- 7.7 14 in. between the load and the fuselage wall on one side of the cabin/hold.
- 7.8 30 in. (square) between the top of the load and the fuselage roof.

Space under the load is not considered for ready access requirements. Experience has shown that ready access is a particular issue for the Chinook and Merlin.

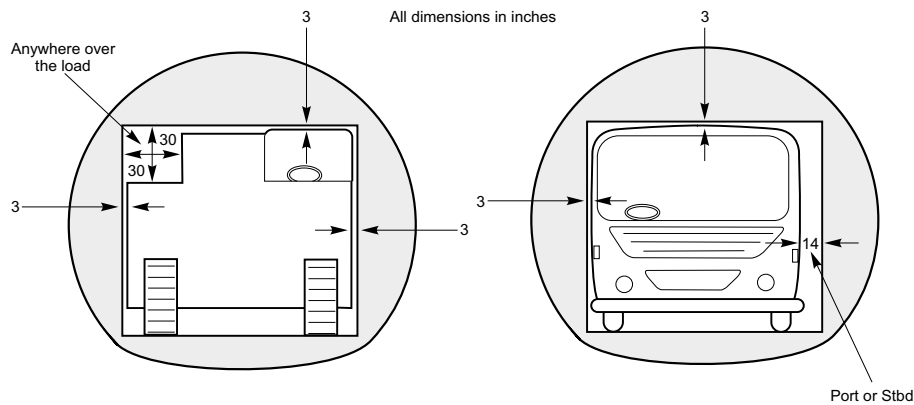

Figure 1 - Minimum clearances and Ready access requirements

## 8 WEIGHT AND BALANCE

Aircraft weight and balance has to be considered for any cargo loaded in the aircraft cargo hold to ensure that the aircraft trim stays within a safe range or envelope. This requirement directly affects the allowable weight distribution in the aircraft. Single load items acceptable to dimensional and floor-loading limitations are not necessarily acceptable for aircraft trim and are always to be considered as part of the overall load. JADTEU will advise as necessary.

The available payload for an aircraft depends on:

- 8.1 The maximum permissible All Up Weight (AUW) of the aircraft. This may vary with temperature, humidity, runway length, and height above sea level, runway load bearing factors and the selected or mandatory cruising height of the route to be flown.
- 8.2 The fuel load (which will depend upon stage lengths), expected weather conditions en-route and the position of diversion airfields etc.
- 8.3 The basic weight of the aircraft. This often varies considerably between individual aircraft of the same type and mark.
- 8.4 The weight of role equipment (loading ramps, dunnage, aircraft pallets etc) and support personnel required for a particular load.

## 9 EQUIPMENT DATA (Information required when requesting airportability clearance)

To assist JADTEU in progressing an airportability clearance as a minimum the following will be required:

- 9.1 An outline drawing of the vehicle or equipment, preferably in pdf or other electronic format. This should show the plan view and both side views including major dimensions to allow JADTEU to produce a scaled outline drawing.
- 9.2 Photographs of the vehicle or equipment.
- 9.3 Weights and dimensions of the vehicle or equipment, in the condition in which it is to be transported (include the weight of each contact point of the load on the aircraft floor).
- 9.4 Compliance with Def Stan 00-003, Section 2, Para 10.
- 9.5 The ultimate strength of all load attachment points in any direction. (Refer to Chapter 2 Para 7 for information on load attachment points).
- 9.6 The ultimate axle/chassis capability of wheeled or tracked equipment (Refer to Chapter 2 Para 2.3).
- 9.7 Vertical centre of gravity.
- 9.8 Concept of Operations.
- 9.9 Dangerous Goods (DG) – Details of DG fitted and carried by the parent equipment (Refer to Chapter 1 Para 18).

## 10 CARGO RESTRAINT

All airlifted loads must be restrained so they will not move during any of the flight conditions that can normally be experienced by the aircraft (take-off, flight and landing) up to extreme flight conditions. Dynamic forces caused by various flight conditions (air turbulence, heavy landings, aggressive flight manoeuvres, survivable crashes, etc.) tend to move the cargo in a forward, aft, lateral or vertical up or down directions, or combinations of these directions. These forces are directly proportional to the cargo object's mass and to the rate of change on the aircraft flight velocity. These forces are commonly expressed in multiples of the acceleration of gravity (g).

These dynamic forces may be resisted by the application of restraining static loads to equal the dynamic loads. With the exception of vertically down, restraining the static load is achieved by using nets, ratchet straps and chains attached to the load and the aircraft. The amount of restraint required in each primary direction (fwd, aft, lateral left, lateral right and vertical up) is equal to the weight of the object multiplied by the g loads as defined in Def-Stan 00-003, Section 2, Para 10. (eg minimum of 3g fwd, 1.5g lateral left and right, 1.5g aft and 2g vertical).

Restraint forces applied to the load to prevent movement are identified by the direction in which the cargo would move if it were unrestrained relative to the direction of flight of the aircraft. Thus, forward restraint prevents the load from moving forward, aft restraint prevent the cargo from moving aft, lateral restraint prevents side to side movement, and vertical up restraint prevents the load from rising off the aircraft floor. Vertical down restraint is provided by the aircraft floor interface.

The contents of all loads and all externally mounted ancillary equipment (e.g. cabin air con units, ISO internal loads, spare wheels, ladders) must also be secured or restrained to the parent load to comply with the requirements of Def-Stan 00-003, Section 2, Para 10.

## 11 AIRCRAFT LOADING METHODS

There are a number of ways to load equipment, the method is normally apparent by the size, weight and load design. Put simply, the load has to be capable of being moved up a ramp or be secured onto aircraft pallets that can then be loaded from a transfer loader onto an aircraft by moving the pallet over floor located rollers.

## 12 DRIVEN IN

If a vehicle has enough power it could be driven or reversed up an aircraft ramp (Figure 2). Amongst other factors, consideration has to be given to the ground clearance and vehicle overhangs to ensure sufficient clearances to the aircraft is achieved. The aircraft data sheets (Annexes A to D) show the aircraft ramp angles when on a level surface, if the ramp angle presents a problem approach angles could be reduced by use of additional ramps or shoring (softwood planks), or the ramp could be used as a lift (C-17A only), JADTEU will advise.



Figure 2 - C-17A - Loading a MAN SV.

### 13 WINCHED IN

If a load is to be winched using the internal aircraft winch, it would normally be winched in backwards and there must be sufficient clearances to allow the load to traverse the ramp (Figure 3). The load must have winch attachment points rated to take the calculated line pull and capable of taking a chain winch bridle or chains. The number of winch attachment points will depend on the weight of the load. In the case of trailers, the jockey wheel must be capable of taking the load that would be transferred to it when traversing backwards up an aircraft ramp.



Figure 3 - Cabin on mobiliser wheels winched into a C-17A

## 14 PALLETISED LOADS

Equipment can be loaded by securing the load to an aircraft pallet (or linked pallets) (Figure 4). The aircraft pallet is then loaded onto a transfer loader that will transfer the load onto the aircraft. This method will limit the weight and size of the load because of a number of factors, the pallet size and load limitations, capability of the transfer loader, aircraft roller limitations. Palletising of loads is normally used for flat bottomed equipment such as ISO containers or smaller items of equipment (wheeled or flat bottomed). A load that is secured to a pallet with an air cargo net cannot overhang the pallet. Cargo, when secured with an air cargo net on a single pallet, must be within the pallet surface area of 104 in. x 84 in. JADTEU will advise.



Figure 4 - Palletised trolley - secured to air cargo pallet with an aircraft net

## 15 TIE DOWN SCHEMES/TIE DOWN NOTES

The output from JADTEU will be a loading and restraint procedure, a Tie Down Scheme (TDS) or a Tie Down Note (TDN) incorporated into the relevant aircraft Topic 11B.

## 16 TIE DOWN NOTE (TDN)

A TDN can be produced in some cases for vehicles and equipment that are found to conform mainly to 'general cargo' parameters but specific points (which may be mandatory) need to be highlighted. The equipment could be loaded and restrained in accordance with the general principles promulgated in DAP 101A-1101-1 and in conjunction with the relevant aircraft loading manual. A typical example of a TDN is at Figure 5.

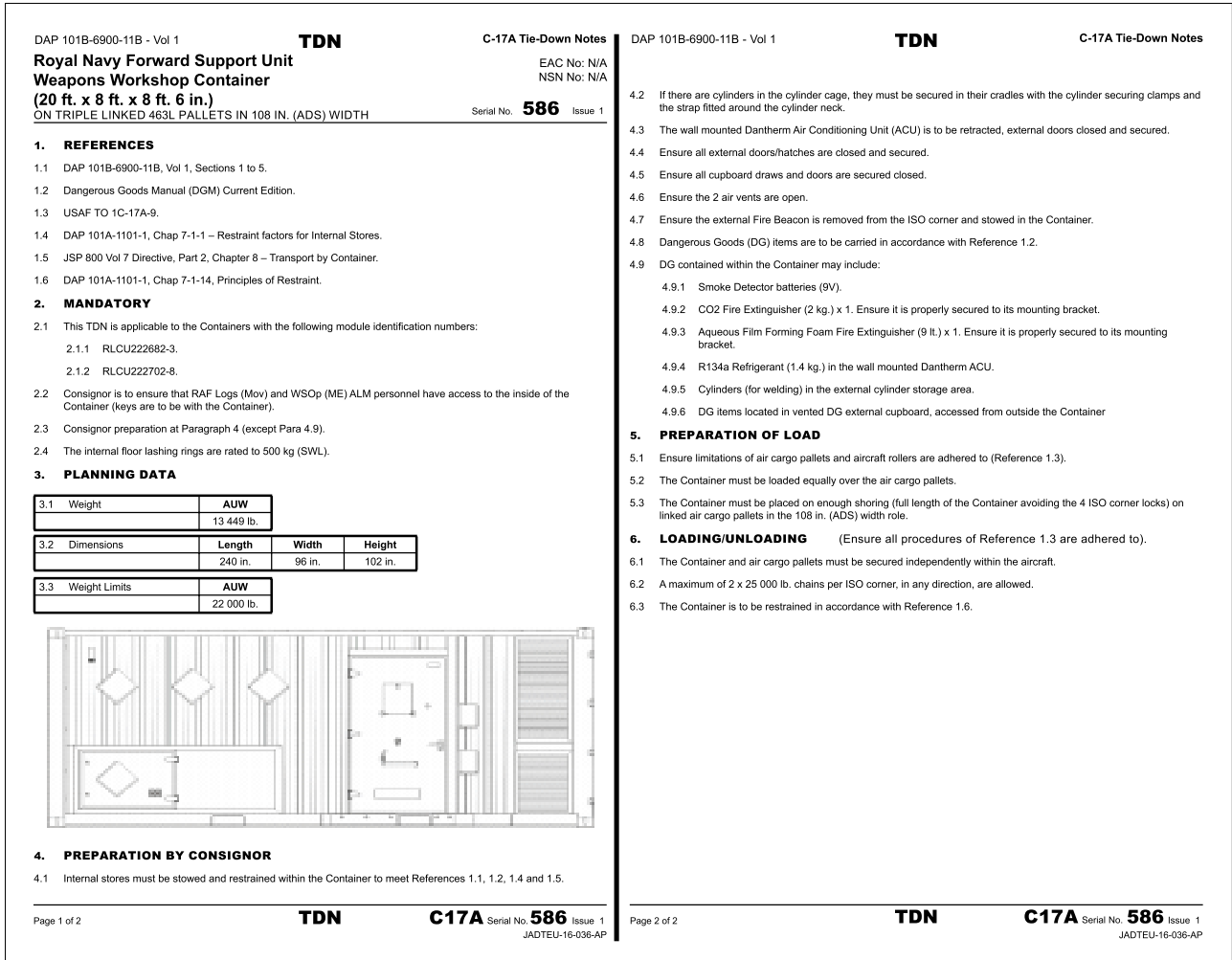

Figure 5 - Example of C-17A TDN

**17 TIE DOWN SCHEME (TDS)**

A TDS is the most common output; it is a more detailed loading document than a TDN. It will provide all the necessary guidance information to plan the load, carry out the consignor preparation of the item, for air transport and to load/unload and restrain to the aircraft. It will normally contain mandatory requirements, typically these would be the consignor preparation (e.g. component removal, provide tie down shackles) and provision of qualified personnel to operate the equipment when loading. Task Sponsors should take note of the consignor requirements as they will be responsible for ensuring user units are aware, and it may incur further cost. A typical example of a C-17A TDS is shown at Figure 6.

Page 1 of 3

C-17A Serial No. 593A Issue 1 JADTEU-20-118-AP

**C-17A Tie-Down Scheme**  
**Mercedes Benz Sprinter Van AWD – Gasket 1c**  
**(DSTL – Van A and Van B) \*Sprinter**  
 DRIVEN IN - CENTRE LINE.  
 NSN No. 2320-99-337-1921 (VAN A)  
 NSN No. 2320-99-671-3797 (VAN B)

DAP 101B-6900-11B - Vol 2

C-17A Tie-Down Schemes

LAPs	Restraint Location
1 and 2	Around front axle forward wishbone arms.
3 and 4	Through most forward Load Attachment Points (LAPs).
5 to 8	Through LAPs in front of rear axle.
9 and 10	Through aft LAPs.
11 and 12	Through LAPs behind rear axle.

**Ancillaries**  
12 x 10 000 lb. chains and tensioners.

**Approach Shoring**  
4 x (72 in. x 10 in. x 2 in.),  
4 x (22 in. x 10 in. x 2 in.),  
4 x (22 in. x 10 in. x 1 in.).

**Parking Shoring**  
6 x (22 in. x 10 in. x 2 in.).

**C-17A** Serial No. **593A** Issue 1

DAP 101B-6900-11B - Vol 2

C-17A Tie-Down Schemes

**Mercedes Benz Sprinter Van AWD – Gasket 1c (DSTL – Van A and Van B) \*Sprinter**  
 DRIVEN IN - CENTRE LINE

Serial No. **593A** Issue 1

**1. REFERENCES**

- DAP 101B-6900-11B, Vol 2, Sections 1-5.
- Dangerous Goods Manual (DGM) Current Edition.
- USAF TO 1C-17A-9.
- AESP 0000-D-000-101.

**2. MANDATORY**

- Cross check the NSN on the vehicle identification plate against the NSNs on page 1 to identify whether the Sprinter is DSTL Van A or Van B.
- The vehicle must be driven by a Suitably Qualified and Experienced Person (SQEP).
- Ensure vehicle ignition is always switched off when not in use, as this will render the vehicle un-serviceable if left turned on.
- Ensure the 3 auxiliary batteries are isolated by operating the isolator switch in the rear office space.
- Vehicles keys are not to be left in the vehicle under any circumstances due to the automatic central locking capability. During flight they are to be removed and left in the custody of the WSO (ME) ALM.
- Consignor preparation - Paragraph 5 (excluding Para 5.3).
- The vehicle cannot be winched as there are no suitable load attachment points.

**3. PLANNING DATA**

3.1 Dimensions	Length	Width	Height
Van A and Van B	279 in.	92 in.	115 in.

NOTE: The weights given are for planning purposes only, use actual weights when available.

3.2 Planning Weights	AUW	RAW	FAW
Van A	10 538 lb.	6217 lb.	4321 lb.
Van B	0000 lb.	0000 lb.	0000 lb.

3.3 Load Stations (subject to trim)	FWD	AFT
Extreme Locations (front axle located)	FS 414	FS 859

NOTE: The front axle must be located on a flight station. When the front axle is located on FS 834 to FS 859, chains 9 to 12 are affected by the compressed grid - therefore these chains are moved aft by 1 TDR.

3.4 Weight Limit of this tie-down scheme	AUW	RAW	FAW
Van A and Van B	11 023 lb.	6669 lb.	4354 lb.

3.5 The All Up Weight (AUW) must not be exceeded as the axle/chassis capability is the limiting factor. The individual maximum axle weights must not be exceeded. The sum of the 2 axle weights must not exceed the AUW.

**4. AIRCRAFT ROLE**

- C-2 - Clear floor.

**LOADING / UNLOADING INSTRUCTIONS**

**5. PREPARATION BY CONSIGNOR**

- Carry out the relevant instructions for the preparation of air transported equipment as detailed in Reference 1.1.
- Provide a SQEP driver to assist with the loading and unloading.

DAP 101B-6900-11B - Vol 2

C-17A Tie-Down Schemes

**5.3** Ensure dangerous goods are prepared in accordance with the current edition of Reference 1.2. The vehicle may include the following dangerous goods:

- Vehicle battery. The vehicle is fitted with 1 x non-spillable batteries located under the vehicle bonnet, isolated by switching off the ignition.
- Auxiliary batteries. 3 x non-spillable batteries located in an underfloor cassette behind the rear axle. Isolated by the isolator switch and RCBO circuit breakers in the rear office space.
- Fire extinguisher. 2 x 2 kg, ABC powder handheld extinguishers inside the vehicle restrained within their housing.
- Refrigerant R134a – Refrigerant contained in standard vehicle air conditioning and additional Webasto air conditioning system for vehicle office space.
- Petrol 2KW Generator – located on the vehicle rear office space floor.

5.4 Ensure all equipment inside the vehicle is stowed/positively restrained.

5.5 If there is equipment stowed on the internal racking, the racking cargo net must be fitted.

5.6 If present, the petrol generator and other equipment should be secured to the office space floor using the vehicle net. The net must be fitted to a minimum of 4 load attachment points (tie down eyes or loading rails) and tensioned using the ratchets in each corner of the net.

**6. PREPARATION OF LOAD**

- Undertake a physical check to ensure that consignor preparation has been completed.
- Obtain accurate axle weights and AUW.
- Calculate the Centre of Balance (CB) and mark on both sides of the Sprinter.

**7. PREPARATION OF AIRCRAFT**

- Prepare the aircraft for loading/unloading from ground level.
- Approach shoring required (Diagram A).

**8. LOADING** (Ensure all procedures of Reference 1.3 are adhered to)

- Position the vehicle in line with the centre line of the aircraft, driven in.
- Locate the parking shoring (22 in. x 10 in. x 2 in.) and step-up shoring (22 in. x 10 in. x 1 in.) for each wheel on the final location.

**CAUTION:** Under body clearances are to be monitored during loading due to the close proximity of rear step to the toe ramps on approach.

- Drive the vehicle into the aircraft and locate on the parking shoring at its final load station.
- Apply parking brake.
- Remove and stow the step-up shoring.
- Ensure battery ignition is 'switched off' at all times when not in use.
- Apply the restraint scheme as shown on page 1.

**9. UNLOADING** (Ensure all procedures of Reference 1.3 are adhered to)

- Reverse of loading pay particular attention to the CAUTION.

**CAUTION:** Under body clearances are to be monitored during unloading due to the close proximity of rear step to the toe ramps.

Page 3 of 3

**C-17A** Serial No. **593A** Issue 1 JADTEU-20-118-AP

Figure 6 - Example of a C-17A TDS.

## 18 DANGEROUS GOODS

JADTEU will request information regarding the Dangerous Goods (DG) applicable to the equipment requiring airportability clearance. All DG must be declared, JADTEU are not the authority on DG and we can only assess the DG against the current regulations. DG is defined by IATA (Dangerous Goods by Air Regulations) and Dangerous Goods Manual (DGM) Current Edition. JADTEU will request the Task Sponsor to provide the following DG information:

- 18.1 Identify all goods classed as DG by IATA that will be air transported with the equipment (Quantity, location and type of DG).
- 18.2 Manufacturers Safety Data Sheets.
- 18.3 Fire Extinguishers/Fire suppressants (type/quantity/how are they isolated etc.)
- 18.4 Fuel – number of fuel tanks, location, fuel tank material, venting?
- 18.5 Batteries – type; quantity; location. How are they isolated?
- 18.6 Security of attachment (e.g Fire Extinguisher mounting bracket).

## 19 PUBLICATIONS

Useful publications include:

- 19.1 Def-Stan 00-003 - Design Guidance for the Transportability of Equipment.
- 19.2 STANAG 7213 – Tactics, Techniques and Procedures for NATO Air Movements (Supersedes STANAG 3400 and 3548). This STANAG refers to ATP 3.3.4.1 as the standard.
- 19.3 Allied Tactical Publication (ATP) 3.3.4.1 – Tactics, Techniques and Procedures for NATO Air Movements.- Chapter 7 (Information on restraint factors and tie down fittings)
- 19.4 ATP 3.2.49.2.2 Technical Criteria for the Transport of Cargo Helicopters (Supersedes STANAG 3542).
- 19.5 The following publications are available through MODNET or from the DefNet Homepage as follows:
  - Publications
  - RAF Publications
  - Air Publications
  - JADTEU
- 19.5.1 DAP101A-1101-1 - Air Transport Operations Manual, General and Technical Information Fixed Wing Aircraft.
- 19.5.2 DAP101A-1105-1C - Air Transport Operations Manual, Carriage of Cargo by Helicopters.
- 19.5.3 DAP101C-0500-11D – Chinook (All Marks) Loading Manual.
- 19.5.4 DAP101C-1703-11D – Merlin Mk 4/4A Loading Manual.
- 19.5.5 DAP101B-6900-11B – Air Transport Operations Manual (C-17A) – Tie Down Schemes.
- 19.5.6 DAP101B-8300-11B - Air Transport Operations Manual (A400M) - Tie Down Schemes.
- 19.5.7 DAP101C-0500-11B - Chinook Air Transport Operations Manual (Chinook all marks) - Tie Down Schemes.
- 19.5.8 Airportability Information and Design Guide.

19.6 TO 1C-17A-9 - C-17A Loading Instructions.

19.7 A400M Loadmaster Operating Manual (LMOM).

19.8 A400M Weight and Balance Manual.

19.9 The following publications are available through the Defence Safety Authority – Movement and Transport Policy:

19.9.1 Dangerous Goods Manual (DGM) Current Edition.

19.9.2 JSP 800 Vol 3 - Movement of Materiel and DCoP 3 - Movement of Materiel by Air.

19.9.3 JSP 800 Vol 6 – Container Management Regulations.

19.9.4 JSP 800 Vol 7 – Load Safety Regulations and Tie Down Schemes.

19.9.5 Defence Land Safety and Environmental Regulations  
- Schedules to Regulation 510 - Schedule 3 - Movement of Materiel by Air.

19.10 The US Department of Defense Interface Standard – MIL-STD-1791 – Designing for Internal Aerial Delivery in Fixed Wing Aircraft (equivalent to Def-Stan 00-003).

19.11 US Department of Defense Interface Standard for Lifting and Tie Down Provisions - MIL-STD-209K.

**CHAPTER 2**  
**PRINCIPLES OF RESTRAINT**  
**CONTENTS**

Para	Page
1 INTRODUCTION.....	19
2 RESTRAINT REQUIREMENTS .....	19
3 RESTRAINT OF EQUIPMENT – GENERAL.....	20
4 TIE DOWN CHAINS.....	21
5 AIRCRAFT FLOOR TIE DOWN POINTS.....	22
6 EQUIPMENT LOAD ATTACHMENT POINTS (LAPs).....	22
7 STRENGTH OF LOAD ATTACHMENT POINTS (LAPs).....	24
8 DISPOSITION OF LOAD ATTACHMENT POINTS (LAPs). .....	25
9 ESTIMATING THE QUANTITY OF EQUIPMENT LOAD ATTACHMENT POINTS (LAPs) REQUIRED .....	25

Figures

Figure 1 - Plan view of a vehicle on a C-17A floor plan – Symmetrical Chain Pattern.....	20
Figure 2 - Example of Tie Down Chain Component Forces .....	21
Figure 3 - C-17A – 25 000 lb. Tie-down chains and tensioners.....	21
Figure 4 - A400M - 4535 kg. Tie-down chain and tensioner .....	22
Figure 5 - Various types of Load Attachment Points.....	23
Figure 6 - Load Attachment Point size reference (Refer to Table 1).....	25

Tables

Table 1 - ATP 3.3.4.1, Chap 7 Dimensions of equipment Load Attachment Point.....	24
--	----

**1 INTRODUCTION**

Items of load carried in an aircraft will resist any change in the speed or direction of flight, i.e. when the aircraft rapidly accelerates (for example during take-off), decelerates, or changes direction. When these conditions are encountered, each item of load will attempt to continue moving at the original speed and in the original direction. Items of load that move are a danger to the crew, passengers and the aircraft structure, therefore every item of load must be restrained, that is the item must be secured to the aircraft to prevent movement. In addition, all load contents and externally mounted items installed to the parent equipment must be positively restrained/attached or contained to withstand the loads specified in Def-Stan 00-003.

The extreme instances of the load attempting to move will occur during an emergency, such as an aborted take-off or a controlled crash landing. Under these circumstances, it is essential that the movement of items of load should not become an additional hazard. The restraint requirements specified below are therefore designed to minimise the possibility of the load moving under forces well in excess of those likely to be encountered during normal flight.

**2 RESTRAINT REQUIREMENTS**

The forces attempting to move the load are expressed in multiples of 'g' (gravitational acceleration). The restraint required to prevent items of load from moving (called restraint factors) are also expressed in terms of 'g'. The restraint to be applied to each individual item of load is always to equal or exceed the 'g' forces likely to be imposed on the item. For example, if the maximum force acting on an item of load is likely to be 3g, then the load must be restrained to an ultimate factor of 3g (3 times the weight of the item). For air transportation the restraint required (restraint factor) is ULTIMATE. Service restraint equipment (used for internal loads) is used at its ULTIMATE strength and restraint attachment points (to be provided on equipment) are to be considered at their ULTIMATE strength (see Para 7).

During flight the forces acting on a load will be of a greater magnitude in some directions than in others; the minimum directional restraint factors are:

2.1 For UK military fixed and rotary wing aircraft operating in the air cargo only transport role.

Forward (against forward movement)*	...	...	3g.
Aft (against movement aft)...	...	...	1.5g.
Vertical (against movement up)	...	...	2g.
Vertical (against movement down)	...	...	4g.
Side (against movement to port or stbd)	...	...	1.5g.

**\*NOTE:**

Def-Stan 00-003 requires 9g forward restraint to be achieved if personnel are in the same compartment as the load (this is true for the Chinook, Merlin, A400M and C-17A), however, there is a dispensation from the Operational Duty Holder (ODH) to deliver as high a forward restraint as is practicable but the restraint achieved must meet the ATP 3.3.34.1 Chap 7 (formerly STANAG 3400) minima of 3g forward. Refer to Def-Stan 00-003, Section 10.

The following additional factors must also be considered:

2.2 Normally vertical (down) restraint is provided by the aircraft floor, with the equipment located on the floor but items suspended above the floor (e.g. equipment attached to the walls of cabins such as air conditioning units, or cabin internal shelving) are to be sufficiently robust so they do not fail when subjected to a 4g vertical down force.

2.3 The axles/chassis of wheeled or tracked equipment have to be capable of supporting an ultimate down force of 4g vertically down without collapsing. This is a low cycle event.

2.4 Additionally, when transporting dedicated air transportable containers (e.g. missile boxes), the containers should be constructed to withstand 4 times the weight of any container(s) stacked on top. (JADTEU can advise).

2.5 The restraint factors given above are an extract from Def-Stan 00-003 (Section 2, Para 10) – refer to this standard for restraint factors as they may be revised periodically. However, all TDSs issued by JADTEU are to deliver as high a restraint as is practicable, but all must meet the ATP 3.3.4.1, Chap 7 minima (formerly STANAG 3400).

2.6 The direction in which the load will face within the aircraft is at the prerogative of JADTEU and is subject to a number of additional considerations not discussed in this Publication, but JADTEU will advise as necessary. This would typically be relevant to ISO containers that could be loaded in either direction.

### 3 RESTRAINT OF EQUIPMENT – GENERAL

Depending on the type of load, type of aircraft and its operating role, load restraint can be achieved by the use of tie-down devices (chains or webbing straps), nets or cabin floor side guidance. Tie down chains are the most adaptable and frequently used items of restraint on fixed wing aircraft.

JADTEU must achieve restraint of a load in accordance with the restraint factors of Def-Stan 00-003. Restraint of the load is normally achieved by attaching sufficient number of restraint devices (tie down chains) to the load, in a symmetrical pattern (Figure 1).

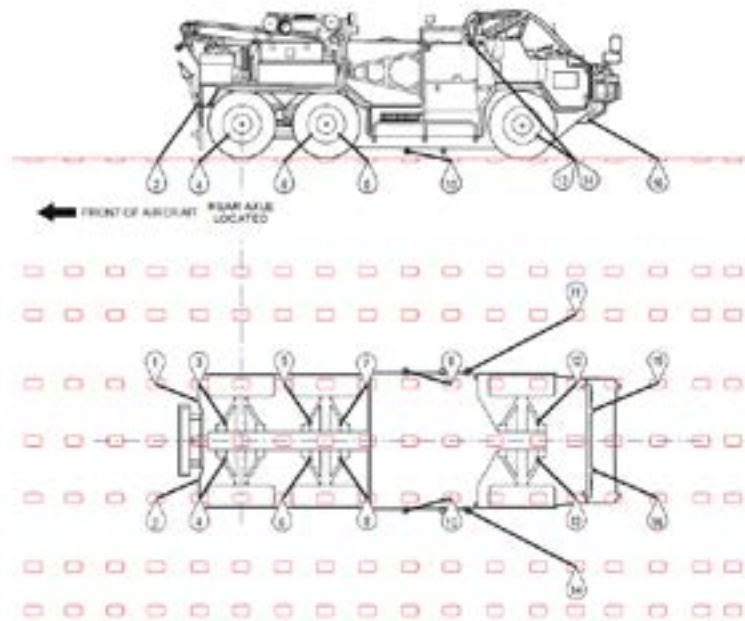

Figure 1 - Plan view of a vehicle on a C-17A floor plan – Symmetrical Chain Pattern

Every tie down chain is capacity-rated based on its ability to withstand a force exerted parallel to and in the opposite direction of its line of application (standard pull test). While it is possible to attach tie down chains to act in the same way, it is not efficient to do so since attachment in such a manner provides restraint against movement in only one direction. Separate acting tie down chains would have to be applied to resist movement in the other directions to fully restrain the item. The total number of tie down chains needed to fully restrain a heavy object in this manner would be prohibitive. By attaching a tie down chain at some angle to the direction of anticipated movement, it is possible to apply restraint in more than one direction, depending on the angle of pull. By varying the angle of pull, one tie down chain can provide simultaneous restraint in three directions.

The tie down shown in Figure 2 will provide simultaneous restraint in all three directions (longitudinal, vertical, and lateral). This illustrates the most desirable and efficient configuration for each tie down chain used. Full restraint of the item in Figure 2 would be obtained by attaching the tie down chain symmetrically, in pairs, to the opposite corners/ends of the cargo item. Each tie down chain attached to the load will provide restraint in the same component directions. By totalling up the sum of the component forces from each tie down chain in each direction (longitudinal, lateral and vertical up) we determine that sufficient restraint of the complete load has been achieved. This is known as orthogonal restraint.

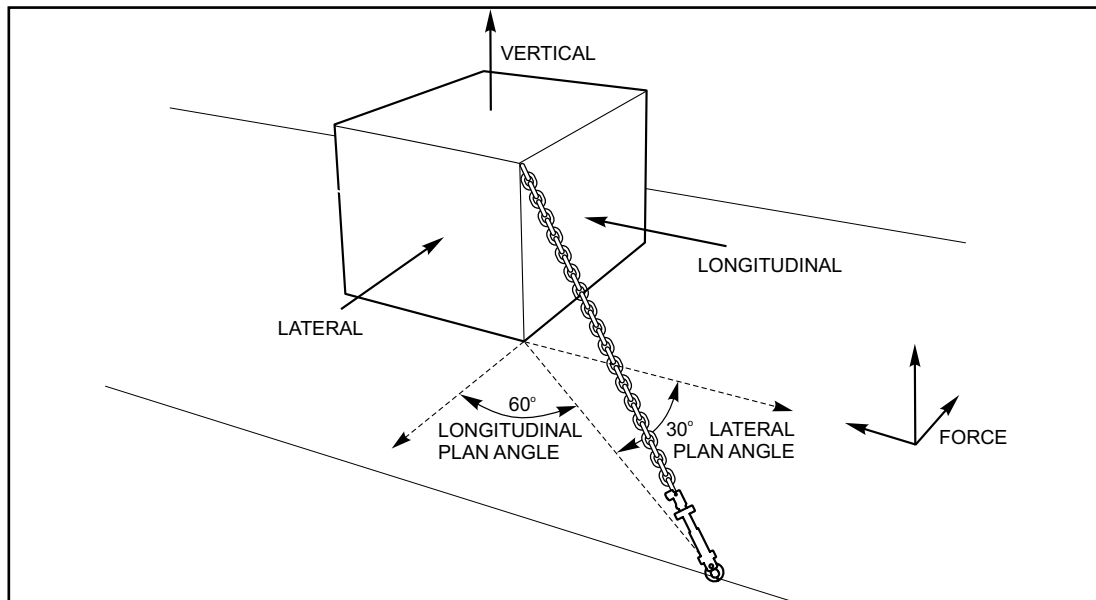

Figure 2 - Example of Tie Down Chain Component Forces

The item sitting on the aircraft floor or the axles/chassis being rated to 4g vertically down achieves vertical down restraint. Items fitted to the parent equipment must be attached or restrained such that if subjected to the 'g' loads specified in Def-Stan 00-003, they will not present a hazard by becoming detached.

#### 4 TIE DOWN CHAINS

The most commonly used method of restraint on fixed wing RAF transport aircraft is the tie down chain and tensioner. Other methods of restraint are webbing ratchet straps and nets; JADTEU will advise on the appropriate restraint device. Only aircraft approved devices can be used for restraint on an RAF aircraft – consult JADTEU if you are considering use of bespoke restraint devices. If a new restraint device is required JADTEU and the Task Sponsor may have to seek the authority of the relevant aircraft platform.

A tie down chain (Figures 3 and 4) consists of a length of chain with a hook at one end. In use the chain is looped around a suitable attachment point on the load and is fastened back on itself by means of a grab hook. The free end of the chain is then gripped by a tensioning device that is attached to the aircraft tie down point on the aircraft floor. The chain tensioner is tightened by hand until the chain is tensioned. The tensioner takes up the chain slack, it does not preload it. Each aircraft platform uses different designs of restraint devices supplied and authorised by the aircraft manufacturer and RAF aircraft authorities.



Figure 3 - C-17A – 25 000 lb. Tie down chains and tensioners



Figure 4 - A400M - 4535 kg. Tie down chain and tensioner

The C-17A and A400M tie down chains are rated to 25 000 lb. (11 340 kg.) and 10 000 lb (4535 kg.).

## 5 AIRCRAFT FLOOR TIE DOWN POINTS

The cargo floor and aircraft ramp is fitted with floor tie down points, the tie down chains are attached to these. The floor points form a grid over the entire cargo floor compartment, the distance between each floor point depends on aircraft type. Refer to the aircraft data sheets at Annexes A to D for the grid pattern on each aircraft type. The floor points on a C-17A and A400M are rated to 25 000 lb. (11 340 kg), these ratings are an ultimate. The floor point is designed to take one restraint chain, as typically the rating of an aircraft restraint chain matches the rating of the floor point however, on the C-17A and A400M 2 x 10 000 lb. (4535 kg.) chains acting in the same direction could be attached to a 25 000 lb. (11 340 kg.) floor point.

## 6 EQUIPMENT LOAD ATTACHMENT POINTS (LAPs)

The LAP on the equipment is the location to which the tie down chain will be attached. LAPs are ideally specifically designed and located for the purpose of restraint. Such items as lifting and tie down rings and clevises are commonly used as LAPs. However, LAPs which naturally result from item configuration are acceptable for use provided their strength is adequate to provide the required restraint. Examples of such LAPs are vehicle frames, axles and cross members, pintle hooks, and cut-outs or other openings in structural members. See some examples at Figure 6.



Figure 5 - Various types of Load Attachment Points.

**7 STRENGTH OF LOAD ATTACHMENT POINTS (LAPs)**

The ultimate strength of LAPs on vehicles and equipment should at least equal the ultimate strength of the tie down device likely to be used. If this requirement cannot be met, the actual ULTIMATE strength of the attachment point should be provided. The essential requirement for an air transportation clearance is that it should not break loose when subjected to the forces detailed in Def-Stan 00-003, Section 2, Para 10.8.6; under such circumstances the possible deformation of the LAP (or damage to the load itself) is not a consideration. A tie down chain cannot be secured to just any convenient location on the equipment without due consideration of the strength of the attachment point and the load path from that attachment point.

For design purposes, it should be assumed that:

- 7.1 Chinook and Merlin All Marks - the tie down chains are rated to 2250 kg. (5000 lb.) ULTIMATE.
- 7.2 A400M and C-17A - the tie down chains are rated to 4535 kg. (10 000 lb.) or 11 340 kg. (25 000 lb.) ULTIMATE. The rating of the tie down device used will depend on the mass and design of the equipment to be restrained.
- 7.3 Vehicle/Equipment LAP Size. The dimensions of LAPs will depend on a number of factors:
  - 7.3.1 The type and rating of the restraint chain (10 000 lb. or 25 000 lb.).
  - 7.3.2 The type and rating of the ratchet strop (5000 lb. or 10 000 lb.).
  - 7.3.3 The ultimate rating of the LAP – this could dictate the type of chain to be used.
  - 7.3.4 Clearance around the LAP, sufficient to allow access for a chain or ratchet strop.

JADTEU will advise on the size of LAPs. Equipment that is to be air transported by A400M must have LAPs that comply with ATP 3.3.4.1 (formerly STANAG 3548). ATP 3.3.4.1, Chap 7, Annex B states that the dimensions of the LAPs are:

<b>CAPACITY</b>	<b>Minimum Diameter 'D'</b>	<b>Minimum Dimension 'H'</b>	<b>Minimum Diameter of Cross Section 'X'</b>
22.24 kN. (5000 lb.)	60 mm. (2.36 in.)	60 mm. (2.36 in.)	11 mm. (0.43 in.)
44.48 kN. (10 000 lb.)	60 mm. (2.36 in.)	67 mm. (2.50 in.)	19 mm. (0.75 in.)
111.2 kN. (25 000 lb.)	76 mm. (3.00 in.)	76 mm. (3.00 in.)	22 mm. (0.87 in.)

Table 1 - ATP 3.3.4.1, Chap 7 dimensions of equipment Load Attachment Point

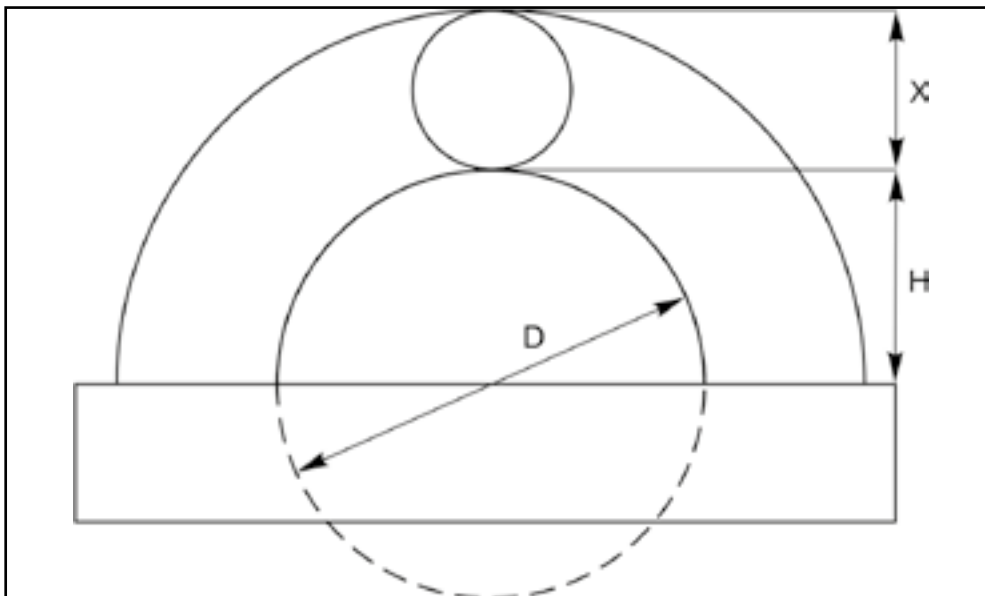

Figure 6 - Load Attachment Point size reference (Refer to Table 1).

**8 DISPOSITION OF LOAD ATTACHMENT POINTS (LAPs).**

Load attachment points provided on the equipment should be positioned in symmetrical pairs, i.e., it is a requirement that a tie down, taken from a floor point on one side of the load, should be matched by one taken from a corresponding point on the opposite side of the load. Ideally each tie down will be attached to provide restraint in 3 directions (orthogonal restraint) and LAPs should be positioned to facilitate this. Load attachment points should be evenly distributed about the load. Some attachment points may have to be fitted to enable tie downs to be attached to the load so that their actual or projected lines of action cross ABOVE the vertical c of g of the load. This ensures that adequate restraint is provided to prevent ‘overturning’ of the load (For further information consult JADTEU). To facilitate the maximum use of available aircraft floor space, the tie downs used for restraint should be arranged whenever possible (although in practice this is often not possible), to terminate at aircraft floor tie down points within the plan outline of the vehicle or equipment.

**9 ESTIMATING THE QUANTITY OF EQUIPMENT LOAD ATTACHMENT POINTS (LAPs) REQUIRED**

Many factors will determine the number of chains required to restrain a load, and therefore the number and location of the equipment LAPs. There is no magic software programme to determine the number of chains required to provide sufficient restraint in all directions (fwd, aft, lateral and vertical up). These will depend on such things as the chain angles, access to LAPs, strength of LAPs (provided the tie down point is rated it is perfectly acceptable to take 2 or more chains from that point). The actual quantity of chains will normally only be determined by attaching the chains to the equipment and aircraft floor points. Chain angles of 30 degrees vertically up from the floor and when viewed from above provides the best compromise for adequate restraint of the load in all directions. However, it is rarely possible to achieve a 30 degree angle due to the configuration of aircraft floor points in relation to the equipment tie down points.

The following formula can be used to estimate the number of restraint chains required, and therefore it follows the number of LAPs required on the equipment. It is assumed that the tie downs are applied to the load at an angle of 30 degrees, both to the aircraft floor and to its centre line. When applied at this angle, the tie down chain will also provide the optimum longitudinal, vertical and lateral restraint. We work out the number of chains required to provide forward restraint, because the chains are at an angle they will also provide lateral and vertical restraint. The number of chains required to give aft (and lateral and vertical) restraint will be half the number required for forward restraint.

The approximate number of tie down chains can be estimated as follows:

$$\text{Forward restraint} = \frac{\text{Equipment weight} \times 3 \text{ (restraint factor of } 3g\text{)}}{50\% \text{ of Tie Down Chain rating}}$$

The answer is rounded up to the nearest even number.

Aft restraint will be 50% of the answer from above (rounded up to the nearest even number).

To estimate the number of chains required for forward restraint for the following tie down chain ultimate ratings:

a. Chinook/Merlin - 2250 kg. tie down chains/strops:

$$\text{Number of chains required} = \frac{\text{Equipment weight} \times \text{restraint factor (3g)}}{(2250 \text{ kg.} \div 2)} = 1125 \text{ kg.}$$

b. C-17A – 10 000 lb. tie down chains:

$$\text{Number of chains required} = \frac{\text{Equipment weight} \times \text{restraint factor (3g)}}{(10\,000 \text{ lb.} \div 2)} = 5000 \text{ lb.}$$

c. C-17A – 25 000 lb. tie down chains:

$$\text{Number of chains required} = \frac{\text{Equipment weight} \times \text{restraint factor (3g)}}{(25\,000 \text{ lb.} \div 2)} = 12\,500 \text{ lb.}$$

**Question:**

What are the estimated number of chains required to restrain a vehicle with an AUW of 52 000 lb. in a C-17A using 25 000 lb. tie down chains?

$$\begin{aligned} \text{No. of Fwd restraint chains} &= \frac{52\,000 \text{ lb.} \times 3g}{12\,500 \text{ lb.}} \\ &= 12.48 \end{aligned}$$

Rounded up to the nearest *even* number = 14 chains for forward restraint

$$\text{No of Aft restraint chains} = 14 \div 2 = 7$$

Rounded up to the nearest *even* number = 8 chains for aft restraint.

**Answer:**

Therefore it is estimated this vehicle will require sufficient LAPs to attach 22 chains - 14 chains for forward restraint and 8 chains for aft restraint, with chains and tensioners that are rated to 25 000 lb.

**CHAPTER 3**

**EQUIPMENT DESIGN - CONSIDERATIONS**

**CONTENTS**

Para		Page
1	INTRODUCTION.....	28
2	DIMENSIONAL CONSIDERATIONS.....	28
3	AIRCRAFT STRUCTURAL LIMITATIONS .....	28
4	SHORING .....	29
5	LOAD ATTACHMENT POINTS (LAPs) .....	30
6	RATING OF A LOAD ATTACHMENT POINT (LAP) .....	31
7	SPRUNG VEHICLES AND EQUIPMENT .....	31
8	WINCHING POINTS .....	32
9	PALLETISED LOADS.....	32
10	DANGEROUS GOODS.....	32
11	AIRWORTHINESS EVIDENCE.....	32
12	LEAFLETS .....	32

Figures

Figure 1 - Approach shoring used to reduce approach angle .....	29
Figure 2 - Rear axle sleeper shoring using standard shoring.....	30
Figure 3 - Front axle sleeper shoring using bespoke sleeper shoring, manufactured from plywood .....	30

Table

Table 1 - Provision, location and rated capacity .....	31
--	----

## 1 INTRODUCTION

Def-Stan 00-003 is the top level publication and is the authority for the air transport of equipment. This chapter provides guidance for those design requirements applicable to equipment intended to be internally air transported in UK Military transport aircraft. It should not be considered definitive; JADTEU should always be consulted for specific design advice. Because of the differences in the characteristics of equipment to be transported and the aircraft used to transport them, not all requirements will apply in every case.

The manufacturer should aim to design the equipment so it can be loaded into an aircraft in its operational configuration. When necessary, sectionalisation or partial disassembly of items may be performed as a means of achieving this goal; however, care must be taken not to exceed the user's organic capability to reassemble the item within a specified period under field conditions. Consideration should also be given to the Concept of Operations (Con Ops). The design and capability of the equipment may be compromised so that it may be transported in a smaller tactical transport aircraft, whereas the Con Ops may require strategic transport in a larger aircraft. The dimensional and structural characteristics of candidate transport aircraft which establish the equipment design limits are summarized in the Annexes A to D for each aircraft. JADTEU must however be consulted on specific details. When considering the aircraft internal dimensions refer to para 2 below for the mandatory clearances to the aircraft structure.

## 2 DIMENSIONAL CONSIDERATIONS

**Cargo compartment clearances:** Equipment and cargo in its prepared airportable configuration shall be sized such that it can be on/offloaded and delivered without causing damage to the aircraft structure or to the equipment/cargo. Equipment/cargo to be air transported shall be designed such that a minimum clearance-between the top/sides of the equipment and aircraft interior is maintained at all times during loading and flight. The minimum clearance during loading is 1 in. (25.4 mm) and when located 3 in. (76.2 mm).

A ready access 'clearway' must also be provided from one end of the aircraft to the other alongside or over the equipment. This must be a minimum of 14 in. on one side or 30 in. square above the equipment. Refer to Chapter 1 Paragraph 7 for more details.

**Equipment Projection limits:** The design of vehicles and other wheeled cargo items which are to be loaded from the ground up the inclined aircraft ramp should aim to be loaded without use of approach shoring (wood planks used to reduce the approach angle to the ramp) while maintaining the cargo compartment clearances. The ramp angles for each aircraft type are shown in Annexes A to D. Equipment height, overhang, and projection limits are established by the Cargo Projection Limits and the Vehicle Projection Limits charts shown in the relevant aircraft loading information publication (JADTEU will advise).

**Vehicle overhang:** Equipment design should minimize front and rear overhang and maximize ground clearance. Overhang should be limited such that interference between the equipment and the ramp or ground is avoided during inclined ramp loading procedures. The design of equipment which are to be loaded from the ground up the inclined aircraft ramp should aim to be loaded without the use of approach shoring while maintaining clearance at the ground as well as at the ramp. Vehicle wheelbase, overhang, and ground clearance limitations are established by the Loading Overhang Limits in the relevant aircraft loading information publication (JADTEU will advise).

**Ramp cresting:** Wheeled/tracked vehicles and other cargo to be loaded from the ground should be able to negotiate the crest of the aircraft inclined ramp without damage to the aircraft or the cargo item. A minimum clearance of 1 in. (25.4 mm) is mandatory when loading. Vehicle and ground clearance dimensions limitations are established by the Ramp cresting limits in the relevant aircraft loading information publication (JADTEU will advise).

**Vehicle/Equipment dimension considerations:** It must be understood even if the vehicle/equipment dimensions meets all the criteria above then it does not mean it can be loaded and restrained in an aircraft. In addition to the dimension limitations above there must be space around the vehicle/equipment for the restraint chains to be attached to the cabin floor. This is sometimes over looked at the design or selection stage of new vehicles/equipment. This is a particular challenge for the Chinook and Merlin.

## 3 AIRCRAFT STRUCTURAL LIMITATIONS

**Aircraft compartment limits:** Equipment shall not impose loads in any compartment in excess of the values shown in the compartment load limit charts for the aircraft under consideration. Both loading and flight limits must be observed and items occupying more than one compartment must be selectively located so they do not overload any compartment. (JADTEU will advise).

**Wheel/tyre loads:** Vehicles and other wheeled equipment shall not impose pneumatic tyre loads or steel/hard rubber wheel loads in excess of the aircraft zone and compartment limitations for both flight and loading conditions. In addition, pneumatic tyres shall not be loaded beyond their rated capacity at the selected inflation pressure. The limit for pneumatic tyre inflation pressure is 100 PSI (6.9 Bar), above this they are considered as solid tyres. The limitation for solid tyres will depend on the tyre width and diameter. Gel or foam filled tyres are to be considered to have the same characteristics as solid tyres. This is a disadvantage over pneumatic tyres. In addition gel filled tyres tend to settle over time resulting in a flat spot, making it difficult to offload.

**Axle loads and axle spacing limits:** Vehicle and other wheeled axle loads cannot exceed the aircraft zone and compartment load limits at the appropriate axle spacing shown in relevant aircraft loading information publication (JADTEU will advise). Both flight and loading limits must be observed

**Concentrated load:** Loads imposed by equipment over relatively small areas of the cargo floor shall not exceed the concentrated load pressures in the relevant aircraft publication. In addition, spacing between load concentrations shall be no less than that specified for the candidate aircraft.

**Linear loads:** Equipment in their airportable configuration shall not impose a running load in excess of the linear floor/ramp loading limits for the zone and compartment applicable to the relevant aircraft loading information publication (JADTEU will advise).

**Treadway/non-treadway loads:** Equipment shall be designed to utilise the higher strength treadway sections of the aircraft floor/ramp whenever such design does not impair item performance. This is most applicable to the A400M, Chinook and Merlin. In all cases, loads imposed by such equipment shall not exceed limit loads for the aircraft zone and compartment under both loading and flight conditions.

#### 4 SHORING

**Shoring:** Shoring is a material used to distribute a load over a larger area. Thus it is possible to carry a load with a higher weight concentration than would normally be allowed. Both plywood and dimension timber are commonly used for shoring purposes. If the loading trial identifies a requirement for shoring that is of a bespoke design the Task Sponsor will be responsible for manufacture and providing it for air transport. JADTEU will produce the design. If bespoke shoring is required it is normally sleeper shoring for vehicles and occasionally approach shoring (ramps). The use of bespoke shoring will be avoided whenever possible, as it will impose additional cost and logistic problems.

**Approach shoring:** Approach shoring is used to reduce the ramp angle that a vehicle must traverse during aircraft on/offloading (Figure 1). Reduction of the ramp angle becomes necessary to avoid interference problems where there are minimal underside, overhead, or overhang clearances. Approach shoring could require large amounts of timber. It should not be considered as an acceptable alternative to a good design that would provide adequate clearances.



Figure 1 - Approach shoring used to reduce approach angle

Floor protection shoring: Shoring that is protecting the aircraft ramps and cargo compartment floor from damage during on/offloading and flight of tracked vehicles or vehicles with wheels that have lugs, cleats, studs, metal rolling surfaces or small diameters.

Parking shoring: Shoring that is required under the wheels or tracks of vehicular cargo to distribute loads.

Rolling shoring: Shoring that is required to distribute weight on the cargo floor during on/offloading.

Sleeper shoring: Sleeper shoring is used to prevent the movement of a vehicle due to gust and flight manoeuvre load conditions where tyres or suspension system cannot withstand these loads without failure or depression producing slack in tie down devices (Figures 2 and 3). This type of shoring is placed between the aircraft floor and a structural part of the vehicle such as the frame.



Figure 2 - Rear axle sleeper shoring using standard shoring.



Figure 3 - Front axle sleeper shoring using bespoke sleeper shoring, manufactured from plywood

## 5 LOAD ATTACHMENT POINTS (LAPs)

Equipment restraint provisions: The equipment shall be capable of being restrained against and withstanding the forces imposed by air turbulence, heavy landings, aggressive flight manoeuvres, survivable crashes, etc. All equipment, except cargo loaded onto 463L air cargo pallets and restrained by aircraft nets, shall meet the applicable requirements of Chapter 2 Para 6 (Equipment LAPs).

Equipment shall be provided with not less than four LAPs which can adequately restrain the equipment when subjected to the accelerations specified in Def-Stan 00-003, Section 2, Para 10.8.6. The LAPs will be capable of accommodating the applicable chains for the aircraft type it will be air transported on. The LAPs shall be capable of accepting the maximum number of tie down devices as required by the tie down grid pattern. These LAPs shall be suitable for use in conjunction with the tie down points on the aircraft floor, which in general, have a capacity of 10,000 lb. or 25 000 lb. Refer to Annexes A to D for the applicable aircraft floor tie down point grid pattern.

**6 RATING OF A LOAD ATTACHMENT POINT (LAP)**

Presenting the rating of a LAP. JADTEU must know the ultimate rating of any LAP provided or identified on the equipment. There are a number of ways these can be presented, the preferred layout would be as shown in Para 6.3:

- 6.1 LAP is rated to 25 000 lb. in all directions.
- 6.2 LAP is rated to 25 000 lb. at an angle between 0 to 45 deg (or 50 or 60 etc - as applicable).
- 6.3 Table 1 provides the rating of the entire permitted LAP (in pounds) in the longitudinal, lateral and vertical directions.

Location	Longitudinal	Lateral	Vertical
Centre LAP	52 800	52 800	52 800
Front LAP	52,800	52 800	52 800
Rear LAP	52 800	52 800	52 800
Forward Lifting Lug	26 400	5 500	26 400
Rear Lifting Lug	13 200	26 400	26 400
Hitch Pin	33 600	33 600	2 240
Front Axle	52 800	52 800	52 800
Rear Axle	52 800	52 800	52 800

Table 1 - Provision, location and rated capacity

**7 SPRUNG VEHICLES AND EQUIPMENT**

Sprung vehicles require special consideration to ensure that movement in flight does not impact the airframe. The sprung part of the load is considered to be anything above and including the spring upper attachment points. All sprung vehicles, including those with torsion bar suspension, are to be restrained to the following rule:

- 7.1 Tie downs providing lateral and longitudinal restraint may be attached either to the sprung or unsprung parts of the load.
- 7.2 For the vertical component, restraint should ideally come from the sprung part of the load. However, when this is impractical, up to 50% of vehicle/equipment restraint may be taken from the unsprung part of the vehicle providing the provisions of paragraphs 7.2.1 and 7.2.2 (below) are adhered to:
  - 7.2.1 Sufficient clearance is to exist between the top of the load and the aircraft roof, so that the load can rise on its suspension without striking the roof when the aircraft is subjected to an acceleration of 2g downwards.
  - 7.2.2 Sufficient clearance is to be provided to allow the load to 'roll' on its suspension, without striking the aircraft structure or other items of cargo.

## 8 WINCHING POINTS

Winching points should be fitted to all equipment that requires towing or winching into the aircraft. The winching points should aim to be of sufficient strength to enable the load to be towed or winched up an incline of at least 17 degrees (A400M - worst case toe ramp angle, refer to Annexes A to D for ramp angles). To enable the in-service towing bridle to be fitted, the minimum working size of the internal cut-out is to be 3 in. x 1.5 in. (76 mm. x 38 mm.). In addition, a minimum of 8 in.(203 mm.) is to be kept clear either side of the towing point to provide sufficient working space for the bridle to be fitted. A minimum of 2 rated winching points will be required on the equipment. Winching points may also be used as load attachment points if they conform to all load attachment point requirements as specified in this publication.

## 9 PALLETISED LOADS

Equipment can be transported on aircraft pallets. These lock into the aircraft integral rail system. Smaller equipment transported on pallets can be secured to the pallet using chains, webbing straps and nets. Larger, heavier equipment (that is within the pallet, aircraft roller and aircraft ground handling equipment limitations) could be transported using the aircraft pallet as a 'skid'. If the pallet is used as a skid the pallet is locked into the aircraft integral rail system; the equipment is then secured directly to the aircraft floor points using aircraft restraint chains. This method is typically used for ISO Containers and cabins.

## 10 DANGEROUS GOODS

Where equipment is capable of carrying or having attached to itself Dangerous Goods (DG), the containment or packaging of these materials shall meet the requirements of IATA Dangerous Goods by Air Regulations and Dangerous Goods Manual (DGM) Current Edition. Contact - SO2 Air-Dangerous Goods Safety Advisor (Air-DG Safety Advisor)-HQ Air-Hurricane Block-RAF High Wycombe for advice. The containment, packaging, or other preparation of these materials shall be performed and certified such that they do not jeopardise the safety of cargo handlers, flight crews, or the aircraft.

## 11 AIRWORTHINESS EVIDENCE

It is the responsibility of the Task Sponsor to ensure that JADTEU are provided with the evidence required to achieve an airportability and airworthiness clearance. JADTEU will request written evidence provided by a competent person that is sufficient to satisfy the airportability and airworthiness assessment of the subject equipment. The equipment has to be shown to comply with Def-Stan 00-003 Section 2, Para 10 and and JADTEU Airportability has to ensure the equipment is loaded and restrained in accordance with Def-Stan 00-003 Section 10. The characteristics of each item of equipment will vary considerably so a definitive list of requirements is difficult to provide. When tasking JADTEU there will be a request for information to provide data on the subject equipment; this should be provided as comprehensively as possible. If there are gaps in information at the time of a task application these will have to be addressed before airportability clearance is achieved. Refer to Chapter 1 Para 9 for guidance on the minimum data required.

## 12 LEAFLETS

Airportability Design Advice for different categories of equipment: Leaflets 1 to 8 provide airportability advice and guidance on different categories of equipment. These are not exhaustive but do highlight many of the common issues experienced by JADTEU. When submitting a task the data requested in the leaflet should be provided. All boxes should be completed (N/A if required); this will form the basis of the airportability assessment. However, JADTEU understands that a fully completed leaflet may not always be possible at the point of task submission. But, the information requested in the leaflet is necessary to provide an airportability clearance. Advice should be sought from the Airportability Trials Management Officer.

## LEAFLET 1 PALLETISED EQUIPMENT

### 1 463L Air cargo pallet

Equipment could be transported on aircraft pallets. The most commonly used pallet in RAF fixed wing aircraft is the 463L Air Cargo Pallet (C-17A and A400M). A 463L pallet is 108 in. x 88 in, it is of riveted aluminium alloy construction, the useable flat surface is 104 in. x 84 in. Twenty two tie down rings (rated to 7500 lb. in all directions) are fitted around the periphery of the pallet outside frame to accept net anchor hooks, chains, tensioners etc. The 463L pallet is not cleared for the Chinook.

### 2 General Cargo

Equipment classed as General Cargo is routinely loaded on pallets; they are also used for flat bottomed equipment such as containers or non-wheeled Ground Support Equipment. A single pallet weight limit is 4535 kg. (10 000 lb.), equipment is normally secured using a 10 000 lb. rated air cargo net. The maximum height of a palletised load when secured by a cargo net is 96 in. (2438 mm.). Pallets can be linked together to allow for larger loads. However, if the cargo is secured by nets a weight limit of 4535 kg. (10 000 lb.) still applies, also the load cannot overhang the pallet when netted. JADTEU must be consulted on the specific requirements for individual equipment that may be transported by air cargo pallets.

For a single pallet the load cannot extend beyond 104 in. x 84 in. However, pallets can be linked together, so JADTEU will advise.



Image 1 - Palletised equipment loaded into a C-17A using an Atlas Transfer Loader



Image 2 - SUV secured by linked Air Cargo Nets to linked 463L Pallets



Image 3 - Item secured to 463L Pallet using 5000 lb. chains

**3 Leading Particulars of 463L Air Cargo Pallet (ACP)**

Air Cargo Pallet .....	1670-00-820-4896.
Planning weight of pallet.....	269 lb. (122 kg.).
Planning weight of pallet plus 4535 kg. net .....	357 lb. )162 kg.).
Overall dimensions.....	108 in. (L) x 88 in. (W) x 2.19 in.(H).
Useable Surface Area.....	104 in. (L) x 84 in. (W).
Load capacity (with Air Cargo Net).....	10 000 lb. (4535 kg.).

**Maximum permissible loading:**

Uniformly distributed.....	10 000 lb. (4535 kg.).
Concentrated .....	250 lbf/in <sup>2</sup> . (175 800 kg.).

Maximum height of load C of G (measured from surface of pallet).....	48 in. (1219 mm).
Max height of a load secured with an Air Cargo Net (measured from surface of pallet) .....	96 in. (2438 mm).

**Tie-Down Rings (rated to 7500 lb.):**

On each 108 in. side.....	6
On each 88 in. side.....	5

**C-17A only**            463L ACP can be loaded in different orientations. Logistics (LOGS) 88 in. width or Aerial Delivery System (ADS) 108 in. width.

**A400M**                    463L ACP can only be loaded in ADS 108 in. width.

**A400M and C-17A**    Maximum height of a load from ACP surface, when restrained with an Air Cargo Net, is 96 in. (2438 mm).

#### 4 Single 463L Air Cargo Pallet (ACP) Dimensions

Overall Dimensions ADS

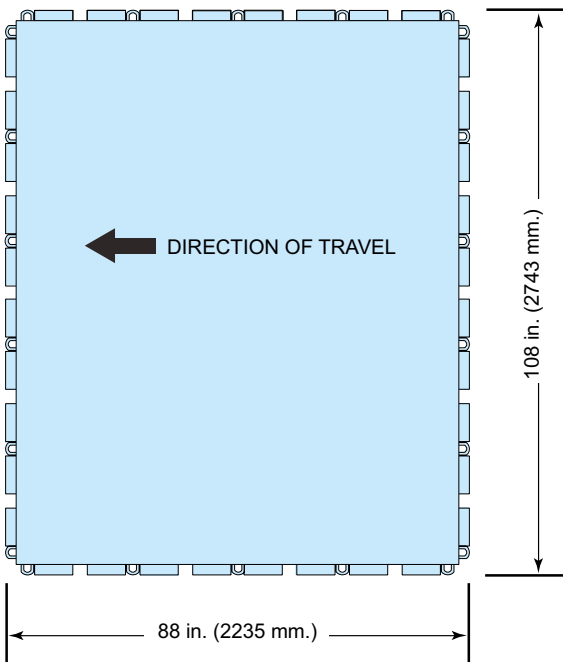

Overall Dimensions LOGS

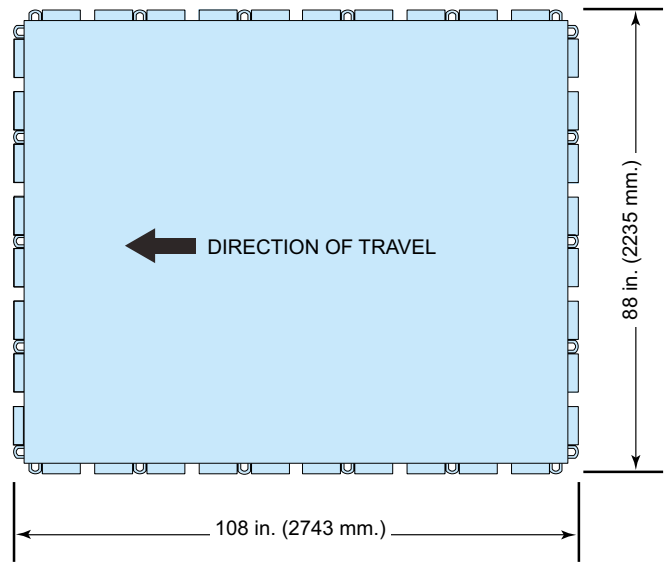

Useable Surface Area Of 463L ACP

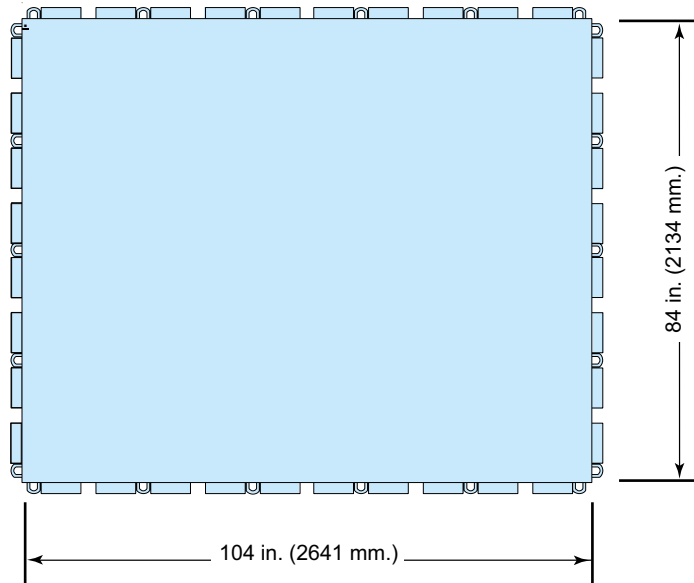

When the load is restrained with an air cargo net, the load cannot overhang the pallet surface area.

### 5 Double Linked 463L ACP Dimensions

LOGS - Double ACP - Dimensions

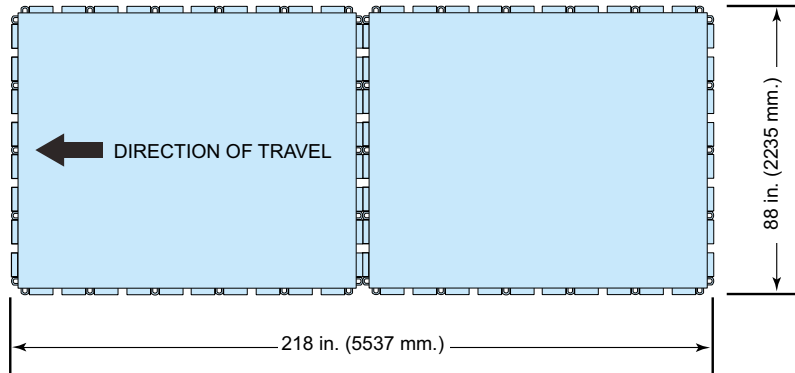

LOGS - Double ACP - Dimensions of Usable Surface

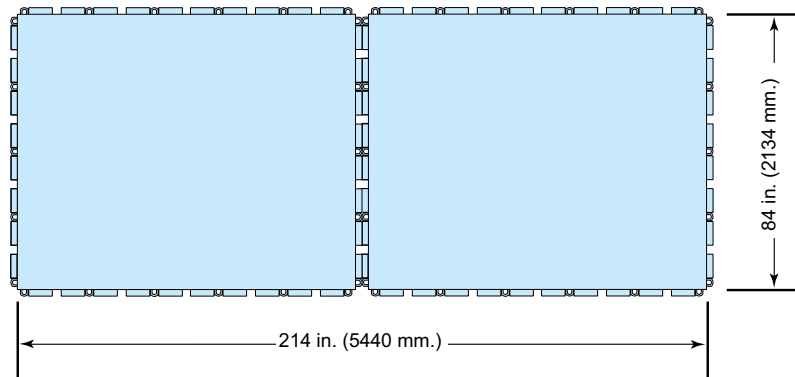

ADS - Double ACP - Dimensions

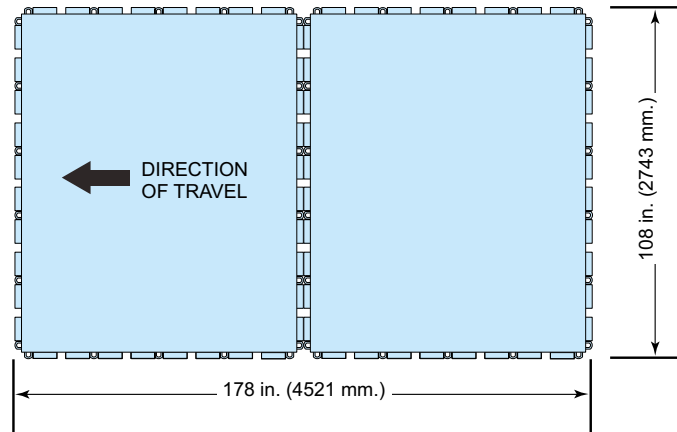

ADS - Double ACP - Dimensions of Usable Surface

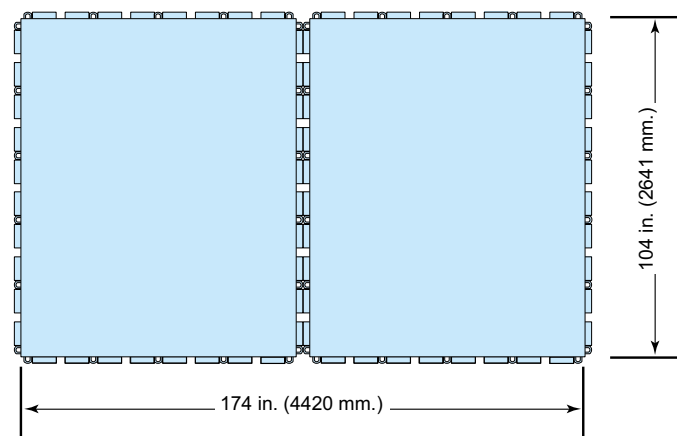

## 6 Triple Linked 463L ACP Dimensions

LOGS - Triple Linked ACP - Dimensions

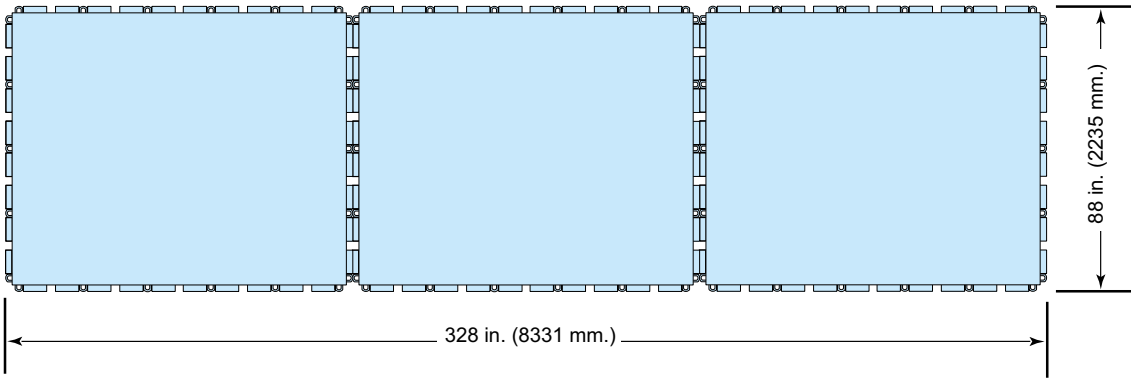

LOGS - Double ACP - Dimensions of Usable Surface

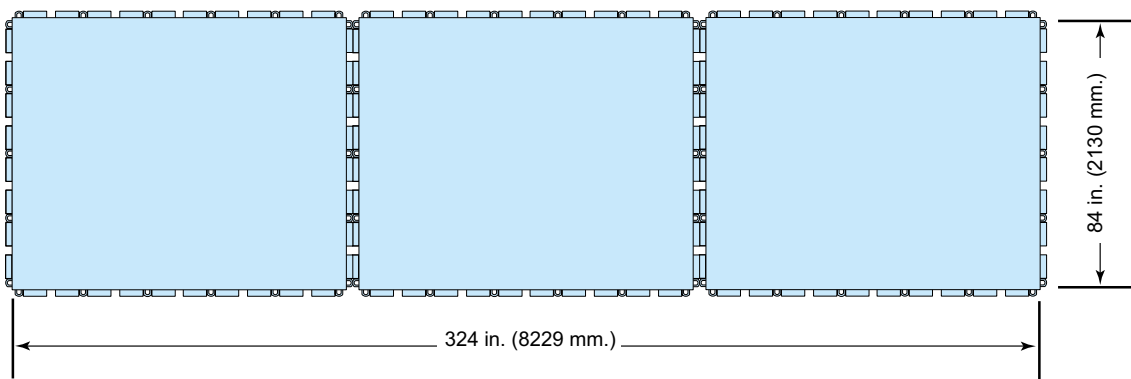

ADS - Triple ACP - Dimensions

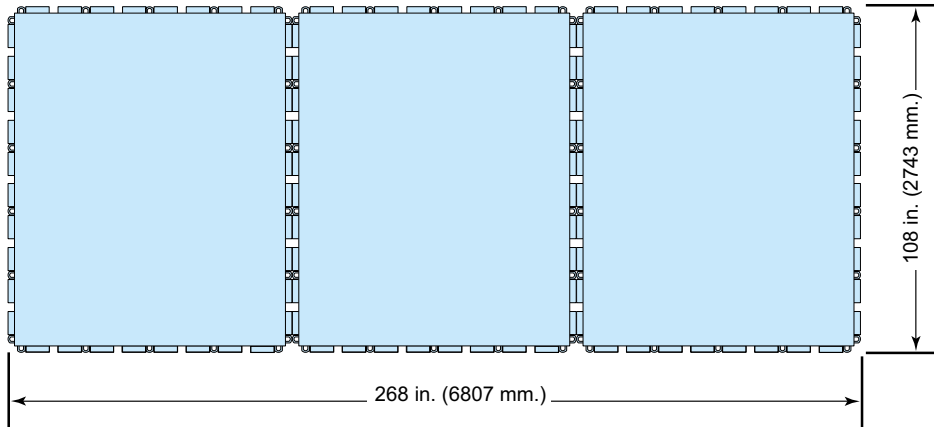

ADS - Triple ACP - Dimensions of Usable Surface

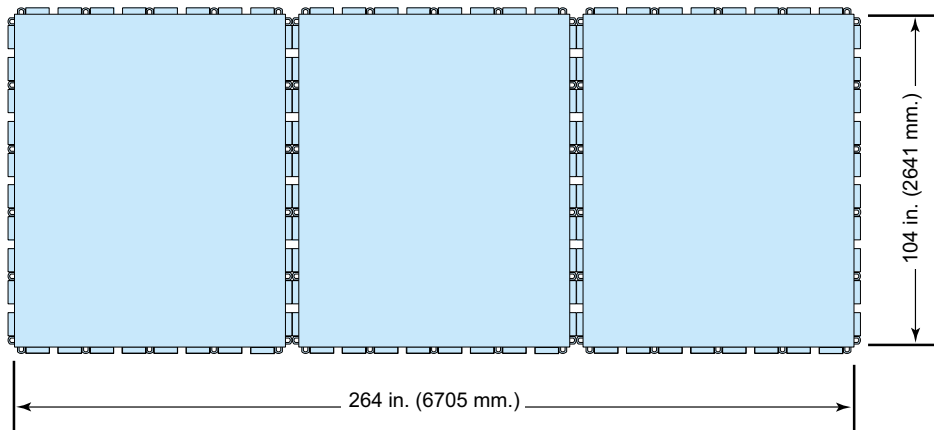

## 7 Quadruple Linked 463L ACP Dimensions

LOGS - Quad Linked ACP - Dimensions

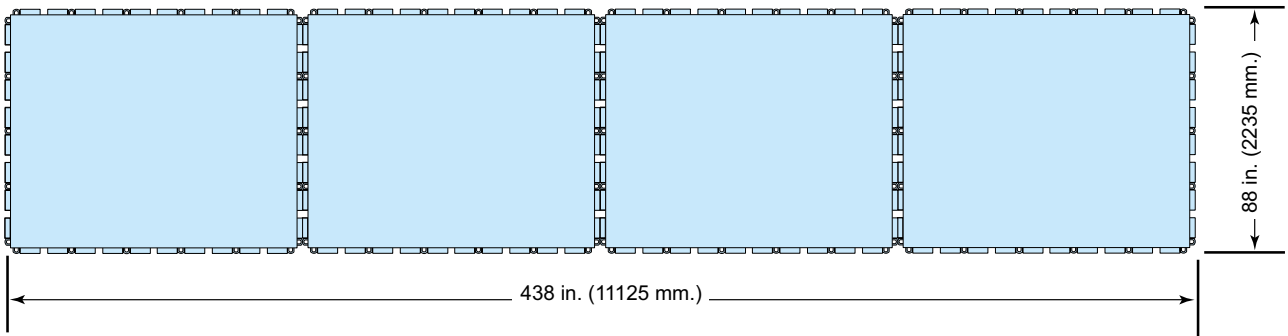

LOGS - Quad ACP - Dimensions of Usable Surface

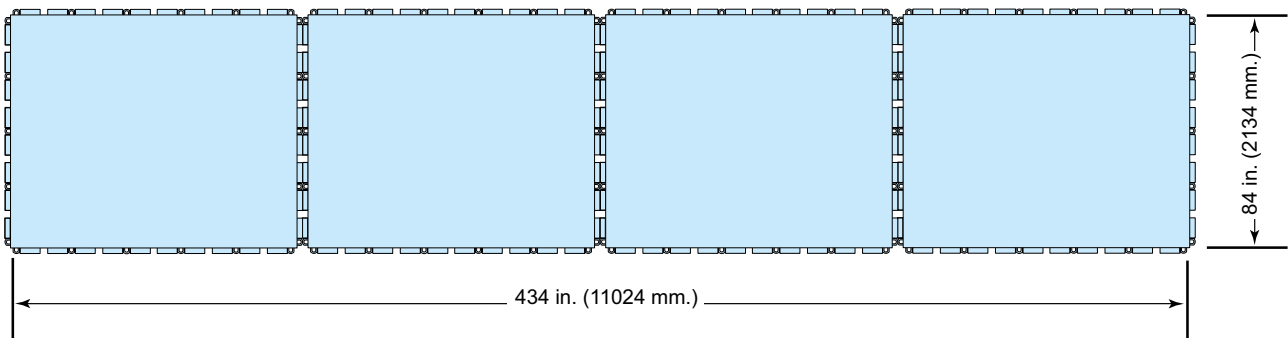

ADS - Quad ACP - Dimensions

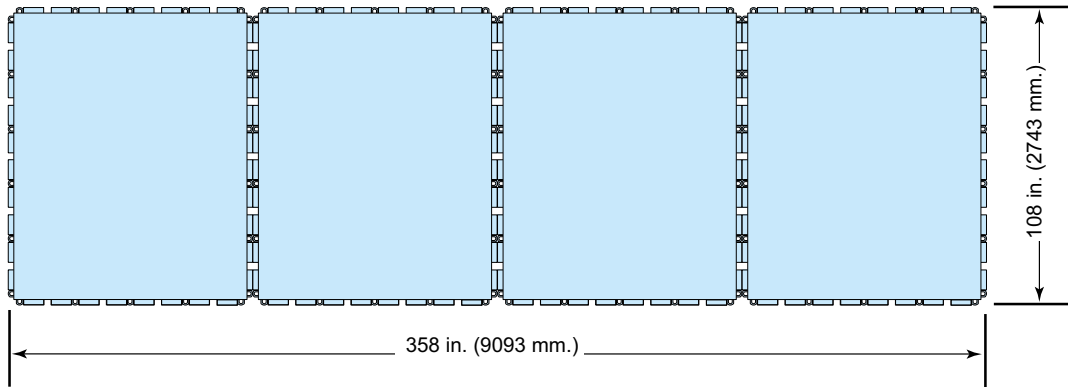

ADS - Quad ACP - Dimensions of Usable Surface

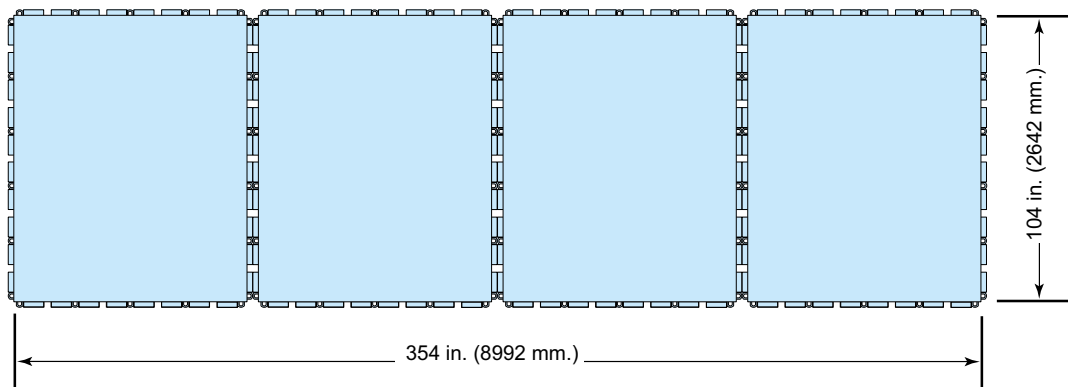

**LEAFLET 2 VEHICLES - WHEELED**

**1 Ramp angles**

Wheeled vehicles will normally be driven or reversed up an aircraft ramp. They should be capable of traversing a ramp angle of 15 degrees (C-17A); this can be reduced to 9 degrees (C-17A). The A400M ramp angle is 12 degrees, which can be reduced to 8 degrees by 'kneeling' the aircraft. The A400M toe ramps are 16.5 degrees, these can be reduced to 11 degrees by using metal ramp extensions.

Aircraft	Main Ramp Angle	Toe Ramp Angle	Reduced Toe Ramp Angle (using Ground Handling Ramps)
C-17A	9 Deg	15 Deg	9 Deg
A400M	12 Deg	16.6 Deg	11 Deg
A400M (Kneeled)	8 deg	16.5 Deg	11 Deg
Merlin	19 Deg	N/A	N/A
Chinook	6 Deg	6 Deg	Not Applicable

The designer should be aware of the structural limitations of the aircraft it is intended to fly in, considering the axle spacing, axle pitch and axle weights. Pneumatic tyre pressure limit is 100 PSI (6.9 bar). Although the vehicle height may be within the limit of the aircraft cabin, the vehicle overhang and projection may cause it to contact or become too close to the aircraft structure when moving up the ramp. Ground clearance should also be considered, low mounted equipment may reduce ground clearance and cause the underside of vehicle to come in to contact with the ramp.

The vehicle will normally be restrained with chains, typically attached to axles, recovery eyes, suitable structure and fitted tie down shackles.

Any fitted equipment (e.g. spare wheels, ladders, crane turntables, jibs) must be attached such that they will not fail when subjected to the g forces quoted in Def-Stan 00-003.



Image 1 - Mercedes Benz Sprinter



Image 2 - Restraint chains attached to fitted vehicle load attachment points

**NOTE**

Not all chains necessary for this vehicle are shown.

**LEAFLET 2**  
**VEHICLES WHEELED - EVIDENCE FOR JADTEU AIRPORTABILITY ASSESSMENT**

Vehicle Name

Vehicle Description

NSN

EAC

GEMS

MOD Task Sponsor

Manufacturer

Manufacture Contact Person

External Dimensions (mm. & in.)

Weight (kg. & lb.) (Prepped for Air Transport Configuration)

Individual Axle Wts (kg. & lb.) (Prepped for Air Transport)

Max AUW (kg. & lb.)

Individual Max Axle Wts (kg. & lb.)

Date

This leaflet is a guide for the presentation of evidence to JADTEU to gain airportability clearance.

This leaflet should be submitted to JADTEU, with all content considered and signed off by a competent person.

All equipment presented for trial or assessment by JADTEU is to be representative of Theatre Entry Standard or in the configuration that it would be presented for air transport. It should be fully fitted out and at the representative weight that it will be transported.

**DEF-STAN 00-003, SECTION 2, PARA 10**

- 1 Has the equipment been designed to comply with Def-Stan 00-003, Section 2, Para 10?      Yes                      No

**LOAD ATTACHMENT POINTS**

- 2 Is the vehicle fitted with bespoke load attachment points to be used for restraining the vehicle in an aircraft?      Yes                      No

3 State the quantity, type and location of the load attachment points.

4 What is the ULTIMATE rating of the load attachment points? (See AP Design Guide Chapter 3)

5 What limitations, if any, are there on the angle of restraint chains from the load attachment points?

6 Are the ratings of load attachment points marked on the GSE adjacent to the load attachment points?  
 Is this the Safe Working Load (SWL) or Ultimate Load?  
 What is the safety factor to yield?  
 What is the safety factor to the ultimate tensile stress?

7 What is the internal and cross section diameter of the load attachment points?  
 (Refer to Chapter 2, Para 7).

8 Are there any locations on the structure that could be used to attach restraint chains?

9 If so, what is the **ULTIMATE** rating of the load attachment points on the structure? (i.e can 10 000 lb. or 25 000 lb. chains be attached to the structure).

**WINCHING POINTS**

10 Is the vehicle fitted with recovery eyes?      Yes                      No

11 Can these be used for restraining the vehicle in an aircraft?      Yes                      No

12 Do the recovery eyes comply with any STANAGS, Def-Stan or Mil Standard? If so state which ones.

13 State the quantity, type and location of the recovery eyes.

14 What is the **ULTIMATE** rating of the recovery eyes?

15 What limitations, if any, are there on the angle of restraint chains from the recovery eyes?

16 Are the ratings of recovery eyes marked on the vehicle adjacent to the load attachment points? Is this the Safe Working Load (SWL) or Ultimate load? What is the safety factor to yield? What is the safety factor to the ultimate tensile stress?

17 What is the internal and cross section diameter of the recovery eyes? (Refer to Chapter 2, Para 7).

#### **AXLES**

18 Can restraint chains be attached to the axles?      Yes                      No

19 Which axles can restraint chains be attached to?

20 What are the axles rated to when they are used as load attachment points?

Is this **ULTIMATE** or Safe Working Load?

**OR**

How many 25 000 lb. or 10 000 lb. chains can be attached to the axles for restraint?

(e.g. Front Axle - 2 x 25 000 lb. chains in the forward and aft direction. Rear Axle - 2 x 25 000 lb. chains in one direction only).

- 21 Are the axles rated to take a 4g vertical down force? (This is an ultimate force, not the designed load. This would be a very low cycle, static load, almost once only event that may occur in the event of an aircraft emergency).

## GENERAL

- 22 Is there a JSP 800 Vol 7 Leaflet? If so, please include details.

- 23 Internal Equipment.

Is all internal equipment exceeding a mass of 23 kg. (50 lb.) positively restrained or contained to meet the load factors of Def Stan 00-003, Section 2, Para 10.8.6 (3g fwd, 1.5g lateral, 2g up, 1.5g aft and 4g down)? (Note: all internal equipment must be restrained or contained).

**Provide evidence to show how all internal equipment exceeding a mass of 23 kg. (50 lb.) (e.g Vehicle Jack, Weapon System, Sand Ramps, Jerry Cans) are restrained or contained to meet the load factors of Def Stan 00-03, Section 2, Para 10.8.6 (3g fwd, 1.5g lateral, 2g up, 1.5g aft and 4g down)?**

24 External Equipment.

Is all external equipment positively restrained to meet the load factors of Def Stan 00-003, Section 2, Para 10.8.6 (3g fwd, 1.5g lateral, 2g up, 1.5g aft and 4g down)?

**Provide evidence to show how any external equipment is restrained to meet the requirements of Def Stan 00-003, Section 2, Para 10.8.6 (3g fwd, 1.5g lateral, 2g up, 1.5g aft and 4g down)?**

25 Provide details of externally mounted equipment (i.e. Spare wheels; crane jib; tipper body etc).

26 Provide evidence that externally mounted equipment listed above is secured to meet requirements of Def-Stan 00-003, Section 2, Para 10.8.6 (3g fwd, 1.5g lateral, 2g up, 1.5g aft, 4g down). Describe how this equipment is secured (ie. locking pins, slew locks, ratchet strops etc).

27 What is the VERTICAL C of G position of the vehicle when prepped for air transport?

28 Is there any aspect of the equipment that could present a hazard because of differential air pressure conditions – as detailed in Def-Stan 00-003, Section 2, Para 10.11?

29 Are there any specific requirements required to cope with differential air pressure (opening of vents, inward/outward relief valves)?

30 Is the equipment complete and at the final build standard?

31 What are the individual tyre pressures? (PSI).

32 Are there any specialist operating conditions?

33 Does the vehicle require a specifically qualified person to operate it?

34 Attach drawings to show the general arrangement, plan view, side elevations and overall dimensions in the air transport configuration?

35 If possible, provide photographs of the vehicle.

36 Has a different variant been cleared for air transport in UK military aircraft?

37 Has this vehicle been cleared for airportability in other nation's military aircraft?

**DANGEROUS GOODS (DG) - DG HAS TO BE CLEARED IAW IATA DG REGULATIONS AND DANGEROUS GOODS MANUAL (DGM) CURRENT EDITION.**

38 Does the equipment incorporate any permanent magnets or retain any level of magnetic flux after powering down which could interfere with aircraft systems?

- 39 State the quantity, type and location of any Dangerous Goods (DG). (e.g. Refrigerant, fire extinguishers, batteries, fire suppressant etc).
- 40 Attach the Material Safety Data Sheet (MSDS) for all declared DG.
- 41 Batteries – Is there an Uninterrupted Power System (UPS)?
- 42 Batteries – Describe how all the batteries are isolated? Provide details of the location of isolator switch (es)/circuit breakers.
- 43 Is the vehicle fitted with a Fire Suppression system? If so, how is it isolated to prevent automatic or manual operation?

## **DECLARATION**

To be signed by a competent person.

The person signing below confirms that to the best of their knowledge the details provided in this leaflet are accurate and correct.

Signed:

Name:

Job Title:

Date:

**LEAFLET 3 VEHICLES - TRACKED**

**1 Ramp angles**

Tracked vehicles will normally be driven or reversed up an aircraft ramp. They should be capable of traversing a ramp angle of 15 degrees (C-17A), this can be reduced to 9 degrees (C-17A). The A400M ramp angle is 12 degrees, which can be reduced to 8 degrees by 'kneeling' the aircraft. The A400M toe ramps are 16.5 degrees, these can be reduced to 11 degrees by using metal ramp extensions.

Aircraft	Main Ramp Angle	Toe Ramp Angle	Reduced Toe Ramp Angle (using Ground Handling Ramps)
C-17A	9 Deg	15 Deg	9 Deg
A400M	12 Deg	16.6 Deg	11 Deg
A400M (Kneeled)	8 Deg	16.5 Deg	11 Deg
Merlin	19 Deg	N/A	N/A
Chinook	6 Deg	6 Deg	Not Applicable

The designer should be aware of the structural limitations of the aircraft it is intended to fly in, considering the linear loading and concentrated floor loads. Tracked vehicles normally contact the cargo floor through pads; the pad area needs to be computed to determine allowable floor limitations. Non-articulated suspension causes extreme weight to be concentrated on the ramp/floor crest prior to vehicle teetering onto the cargo compartment floor.

Although the vehicle height may be within the limit of the aircraft cabin, the vehicle overhang and projection may cause it to contact or become too close to the aircraft structure when moving up the ramp. Ground clearance should also be considered, low mounted equipment may reduce ground clearance and cause the underside of vehicle to come in to contact with the ramp.

The vehicle will normally be restrained with chains, typically attached to axles, torsion bars, recovery eyes, suitable structure and fitted tie down shackles.

The vehicle will normally be loaded with wooden floor protection to prevent damage to the aircraft floor.

Any fitted equipment (e.g. spare wheels, ladders, crane turntables, jibs) must be attached such that they will not fail when subjected to the G forces quoted in Def-Stan 00-003.

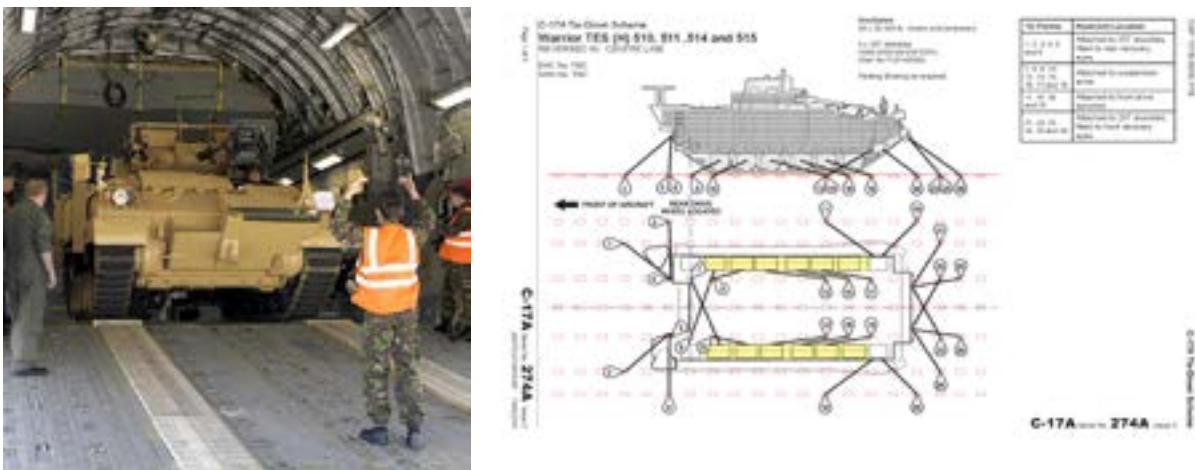

Image 1 - Warrior Armoured Tracked Vehicle on C-17A

**LEAFLET 3**  
**VEHICLES TRACKED - EVIDENCE FOR JADTEU AIRPORTABILITY ASSESSMENT**

Vehicle Name

Vehicle Description

NSN

EAC

MOD Task Sponsor

Manufacturer

Manufacturer Contact Person

External Dimensions (mm. & in.)

Weight (kg. & lb.) (Prepped for Air Transport Configuration)

Max AUW (kg. & lb.)

Date

This leaflet is a guide for the presentation of evidence to JADTEU to gain airportability clearance.

This leaflet should be submitted to JADTEU, with all content considered and signed off by a competent person.

All equipment presented for trial or assessment by JADTEU is to be representative of Theatre Entry Standard or in the configuration that it would be presented for air transport. It should be fully fitted out and at the representative weight that it will be transported.

**DEF-STAN-00-003, SECTION 2, PARA 10**

1 Has the equipment been designed to comply with Def-Stan 00-003, Section 2, Para 10?      Yes                      No

**LOAD ATTACHMENTS POINTS**

2 Is the vehicle fitted with bespoke load attachment points to be used for restraining the vehicle in an aircraft?      Yes                      No

3 State the quantity, type and location of the load attachment points.

4 What is the **ULTIMATE** rating of the load attachment points? (Refer to AP Design Guide, Chapter 3).

5 What limitations, if any, are there on the angle of the restraint chains from the load attachment points?

6 Are the ratings of load attachment points marked on the vehicle adjacent to the tie down points?  
Is this the Safe Working Load (SWL) or Ultimate load? What is the safety factor to yield? What is the safety factor to the ultimate tensile stress?

- 7 What is the internal and cross section diameter of the load attachment points? (Refer to Chapter 2, Para 7).
- 8 Are there any locations on the structure that could be used to attach restraint chains?
- 9 If so, what is the **ULTIMATE** rating of the load attachment points on the structure? (i.e can 10 000 lb. or 25 000 lb. chains be attached to the structure).

#### **RECOVERY EYES**

- 10 Is the vehicle fitted with recovery eyes?    Yes                      No
- 11 Can these be used for restraining the vehicle in an aircraft?    Yes                      No
- 12 Do the recovery eyes comply with any STANAGS, Def-Stan or Mil Standard? If so state which ones.
- 13 State the quantity, type and location of the recovery eyes.
- 14 What is the **ULTIMATE** rating of the recovery eyes?
- 15 What limitations, if any, are there on the angle of restraint chains from the recovery eyes?

16 Are the ratings of recovery eyes marked on the vehicle adjacent to the load attachment points?  
Is this the Safe Working Load (SWL) or Ultimate load? What is the safety factor to yield? What is the safety factor to the ultimate tensile stress?

17 What is the internal diameter of the recovery eyes? (Refer to Chapter 2, Para 7).

#### **SUSPENSION STRUTS**

18 Can restraint chains be attached to the suspension struts/trailing arms?      Yes                      No

19 Which suspension struts/trailing arms can restraint chains be attached to?

20 What are the suspension struts/trailing arms rated to when they are used as load attachment points?  
Is this **ULTIMATE** or Safe Working Load?

**OR**

How many 25 000 lb. or 10 000 lb. chains can be attached to the suspension struts/trailing arms for restraint?  
(e.g. 2 x 25 000 lb. chains in the forward and aft direction).

- 21 Is the vehicle rated to take a 4g vertical down force? (This is an ultimate force, not the designed load. This would be a very low cycle, static load, almost once only event that may occur in the event of an aircraft emergency).

### **TRACK AND SUSPENSION**

- 22 Is the suspension system articulated or rigid?

- 23 What material are the tracks manufactured from?

- 24 Are the tracks fitted with grousers? If so what is the depth of the grouser?

- 25 Provide dimensions and drawings of the track pads.

### **GENERAL**

- 26 Is there a JSP 800 Vol 7 Leaflet? If so, please include details.

- 27 Internal Equipment.  
Is all internal equipment exceeding a mass of 23 kg. (50 lb.) positively restrained or contained to meet the load factors of Def Stan 00-003, Section 2, Para 10.8.6 (3g fwd, 1.5g lateral, 2g up, 1.5g aft and 4g down)? (Note: all internal equipment must be restrained or contained).  
**Provide evidence to show how all internal equipment exceeding a mass of 23 kg. (50 lb.) (e.g Vehicle Jack, Weapon System, Sand Ramps, Jerry Cans) are restrained or contained to meet the load factors of Def Stan 00-03, Section 2, Para 10.8.6 (3g fwd, 1.5g lateral, 2g up, 1.5g aft and 4g down)?**
- 28 Provide details of externally mounted equipment (i.e. Spare wheels; crane jib; tipper body, gun turrets, bar armour etc.).
- 29 How is the gun turret locked into position?
- 30 External Equipment.  
Is all external equipment positively restrained to meet the load factors of Def Stan 00-003, Section 2, Para 10.8.6 (3g fwd, 1.5g lateral, 2g up, 1.5g aft and 4g down)?  
**Provide evidence to show how any external equipment is restrained to meet the requirements of Def Stan 00-003, Section 2, Para 10.8.6 (3g fwd, 1.5g lateral, 2g up, 1.5g aft and 4g down)?**  
Describe how this equipment is secured (i.e. locking pins, slew locks, ratchet strops etc).



37 Attach drawings to show the general arrangement, plan view, side elevations and overall dimensions in the air transport configuration?

38 If possible provide photographs of the vehicle.

39 Has a different variant been cleared for air transport in UK military aircraft?

40 Batteries – Is there an Uninterrupted Power System (UPS)?

**DANGEROUS GOODS (DG) - DG HAS TO BE CLEARED IAW IATA DG REGULATIONS AND DANGEROUS GOODS MANUAL (DGM) CURRENT EDITION.**

41 Does the equipment incorporate any permanent magnets or retain any level of magnetic flux after powering down which could interfere with aircraft systems?

42 State the quantity, type and location of any Dangerous Goods (DG). (e.g. Refrigerant, fire extinguishers, batteries, fire suppressant etc).

43 Attach the Material Safety Data Sheet (MSDS) for all declared DG.

44 Batteries – Is there an Uninterrupted Power System (UPS)?

45 Batteries – Describe how all the batteries are isolated? Provide details of the location of isolator switch (es)/circuit breakers.

46 Is the vehicle fitted with a Fire Suppression system? If so, how is it isolated to prevent automatic or manual operation?

**DECLARATION**

To be signed by a competent person.

The person signing below confirms that to the best of their knowledge the details provided in this leaflet are accurate and correct.

Signed:

Name:

Job Title:

Date:

## LEAFLET 4 TRAILERS

### 1 Normal procedure

Trailers will normally be winched up the ramp, reversed in. They are not normally towed onto the aircraft with a prime mover.

### 2 Major airportability design considerations are:

- 2.1 Winched in backwards – a minimum of 2 points of known strength at the rear to attach the winch.
- 2.2 Winch attachment points should be low down, at the rear.
- 2.3 Ground Clearance – consider overhang and ground clearance to ensure the ramp is cleared.
- 2.4 Double Axle or Triple Axle– a double axle tends to cause the jockey wheel to float, causing the tow bar to rise dangerously. This can be mitigated by raising the ramp towards co-planar and or adjusting the jockey wheel height.
- 2.5 Jockey wheel – when a trailer is winched up the ramp incline significant weight transference onto the jockey will occur. Before loading, JADTEU will require evidence that the jockey wheel can support the loads that may be expected. Most jockey wheels are solid wheels. This often causes an issue of exceeding aircraft floor loading. This can be mitigated by using rolling shoring, which adds time and complexity to aircraft loading. If possible, a pneumatic tyre is preferred.
- 2.6 The trailer drawbar will be located on a shoring stack when located in the aircraft. The jockey wheel will be raised clear of the floor. The drawbar should have a suitable flat area on the underside to locate the shoring. The drawbar is required for steering when winching the trailer into the aircraft.
- 2.7 Boats on trailers. The boat and trailer (unless unitised) will be restrained separately to the aircraft floor. Therefore, the boat and trailer will each require rated load attachment points. The trailer should be capable of supporting the boat/trailer weight at 4g vertical down. For marine craft refer to Leaflet 8.



Image 1 - 24 ft. RIB being winched into the C-17A mock-up



Image 2 - 24 ft. RIB and trailer individually restrained to the aircraft floor

**LEAFLET 4**  
**TRAILERS - EVIDENCE FOR JADTEU AIRPORTABILITY ASSESSMENT**

Trailer Name

Trailer Description

NSN

EAC

MOD Task Sponsor

Manufacturer

Manufacturer Contact Person

External Dimensions (mm. & in.)

Weight (kg. & lb.) (Prepped for Air Transport Configuration)

Individual Axle Wts kg. & lb.) (Prepped for Air Transport)

Jockey Wheel Wt (kg. & lb) (Prepped for Air Transport)

Max AUW (kg. & lb.)

Individual Max Axle Wts (kg. & lb.)

Date

This leaflet is a guide for the presentation of evidence to JADTEU to gain airportability clearance.

This leaflet should be submitted to JADTEU, with all content considered and signed off by a competent person.

All equipment presented for trial or assessment by JADTEU is to be representative of Theatre Entry Standard or in the configuration that it would be presented for air transport. It should be fully fitted out and at the representative weight that it will be transported.

**DEF-STAN 00-003, SECTION 2, PARA 10**

1 Has the equipment been designed to comply with Def-Stan 00-003, Section 2, Para 10?      Yes                      No

**LOAD ATTACHMENTS POINTS**

2 Is the trailer fitted with bespoke load attachment points to be used for restraining the trailer in an aircraft?      Yes                      No

3 State the quantity, type and location of the load attachment points.

4 What is the internal and cross section diameter of the load attachment points? (Refer to Chapter 2, Para 7).

5 What is the ULTIMATE rating of the load attachment points? (See AP Design Guide Chapter 3, Para 6 for preferred layout of data).

6 What limitations, if any, are there on the angle of the restraint chains from the load attachment points?

7 Are the ratings of load attachment points marked on the vehicle adjacent to the load attachment points? Is this the Safe Working Load (SWL) or Ultimate load? What is the safety factor to yield? What is the safety factor to the ultimate tensile stress?

- 8 Is there any structure that could be used to attach restraint chains? (tow bar, trailer framework etc).  
If so, what is the ULTIMATE rating? (i.e. can 10 000 lb. or 25 000 lb. chains be attached to the structure).

### WINCHING POINTS

- 9 Is the trailer fitted with winching points?      Yes                      No
- 10 If there are no winch points is there a location on the GSE to attach chains/chain bridle. (i.e. structure/axles).      Yes                      No
- 11 What is the rating of the winch points?
- 12 What is the location and quantity of the winch points? (Generally a minimum of 2 locations is required at the rear of the trailer). Refer to Chapter 3, Para 8).
- 13 What is the internal diameter of the winch points?
- 14 Are the points identified as winch points?

**AXLES/TYRES**

15 Can restraint chains be attached to the axles?      Yes                      No

16 Which suspension struts/trailing arms can restraint chains be attached to?

17 How many chains (25 000 lb. or 10 000 lb.) can be attached to the axles for restraint?  
(e.g. Front Axle - 2 x 25 000 lb chains in the forward and aft direction. Rear Axle - 2 x 25 000 lb chains in one direction only).

18 Are the axles rated to take a 4g vertical down force? (This is an ultimate force, not the designed load. This would be a very low cycle, static load, almost once only event that may occur in the event of an aircraft emergency).

19 If tyres are pneumatic, what are the tyre pressures?

20 If the tyres are solid, state the following.	Diameter (in.)	Contact width (in.)	Material (Rubber/metal etc)
---	----------------	---------------------	-----------------------------

**JOCKEY WHEEL**

21 Is the trailer fitted with a jockey wheel?      Yes                      No

22 Describe how the jockey wheel is attached to the trailer, locked and height adjusted.

23 What is the maximum weight capacity of the jockey wheel?

24 Will the jockey wheel support the weight transference when the trailer is winched in reversed up an aircraft ramp?

9 Deg (C-17A)

11.5 Deg (A400M)

15 Deg (C-17A)

16.6 Deg (A400M)

25 Is the jockey wheel tyre pneumatic or solid?

26 If tyre is pneumatic, what is the tyre pressure?

27 If the tyres are solid, state the following.

Diameter (in.)

Contact width (in.)

Material (Rubber/metal etc)

**GENERAL**

28 Is there a JSP 800 Vol 7 Leaflet? If so, please include details.

- 29 Describe the type of tow bar. (Swan neck, NATO Standard towing eye, etc).
- 30 Is the trailer equipped with stabiliser legs? Are these rated to 4g down?
- 31 In simple terms describe how to operate the brake system.  
Do the brakes require air pressure to operate? How many brake operations are there when the air tank is fully charged?  
Do the brakes lock on if the air pressure is dissipated? Can the brakes be mechanically released in the event of the air pressure discharging?  
If applicable, describe how the brakes can be mechanically released.
- 32 Internal Equipment.  
Is all internal equipment exceeding a mass of 23 kg (50 lb.) positively restrained or contained to meet the load factors of Def Stan 00-003, Section 2, Para 10.8.6 (3g fwd, 1.5g lateral, 2g up, 1.5g aft and 4g down)? (Note: all internal equipment must be restrained or contained).  
**Provide evidence to show how all internal equipment exceeding a mass of 23 kg. (50 lb.) (e.g Wheel Jack, Weapon System, Sand Ramps, Jerry Cans) are restrained or contained to meet the load factors of Def Stan 00-003, Section 2, Para 10.8.6 (3g fwd, 1.5g lateral, 2g up, 1.5g aft and 4g down)?**
- 33 What is the VERTICAL C of G position of the trailer? If applicable, also state the the vertical C of G with the the load mounted on the trailer.(e,g boat)

- 34 Is there any aspect of the equipment that could present a hazard because of differential air pressure conditions – as detailed in Def-Stan 00-003, Section 2, Para 10.11?
- 35 Are there any specific requirements required to cope with differential air pressure (opening of vents, inward/outward relief valves)?
- 36 Is the equipment complete and at the final build standard?
- 37 Are there any specialist operating conditions?
- 38 Does the trailer require a specifically qualified person to operate it?
- 39 Attach drawings to show the general arrangement, plan view, side elevations and overall dimensions in the air transport configuration?
- 40 If possible provide photographs of the trailer.
- 41 Has a different variant been cleared for air transport in UK military aircraft?

- 42 Has this trailer been cleared for airportability in other nation's military aircraft?
- 43 Provide details of equipment mounted on the trailer (generators, boxes, boat).
- 44 Is the equipment listed at line 43 positively restrained to meet the load factors of Def Stan 00-03, Section 2, Para 10.8.6 (3g fwd, 1.5g lateral, 2g up, 1.5g aft and 4g down)?  
**Provide evidence to show how any external equipment is restrained to meet the requirements of Def Stan 00-003, Section 2, Para 10.8.6 (3g fwd, 1.5g lateral, 2g up, 1.5g aft and 4g down)?**
- 45 Is a marine craft mounted on the trailer? If so, refer to Leaflet 8 and complete it.

**DANGEROUS GOODS (DG) - DG HAS TO BE CLEARED IAW IATA DG REGULATIONS AND DANGEROUS GOODS MANUAL (DGM) CURRENT EDITION.**

- 46 Does the equipment incorporate any permanent magnets or retain any level of magnetic flux after powering down which could interfere with aircraft systems?
- 47 State the quantity, type and location of any Dangerous Goods (DG). (e.g. Refrigerant, fire extinguishers, batteries etc).

48 Attach the Material Safety Data Sheet (MSDS) for all declared DG.

49 Batteries – Is there a Uninterrupted Power Supply (UPS) system?

50 Batteries – How are they isolated – location of isolator switches.

#### **DECLARATION**

To be signed by a competent person.

The person signing below confirms that to the best of their knowledge the details provided in this leaflet are accurate and correct.

Signed:

Name:

Job Title:

Date:

## LEAFLET 5 HELICOPTERS

### 1 Normal procedure

Helicopters with a nose u/c are normally winched in tail boom first. They will either be loaded on their undercarriage or they may be fitted with a jury wheel system (Air Transport Kit – ATK) in place of the undercarriage. This ATK may be used to reduce the height (Merlin HC Mk4) or because the helicopter is fitted with skids (Bell 212). An ATK is also a generic term for the equipment supplied by the consignor required to load and restrain the helicopter. This can include load attachment points (i.e shackles), winch bridles, blade restraint kit, etc.

All helicopters are winched; suitable winch attachment points will be required.

Sufficient load attachment points will be required, due to the nature of helicopter design it can be difficult to achieve. Other methods used are load beams that pass through the cabin to which chains are attached.

The undercarriage (or if an ATK is fitted) must be rated to 4g vertical down.

If transported with main rotor blades fitted – suitable blade support/attachment will be required, securing the blades in all directions in compliance with Def-Stan 00-003, Section 2, Para 10.

Load attachment points may be fitted to the ATK; the ATK must be attached to the helicopter to take the loads that may be imparted under flight conditions (Def-Stan 00-003).

Helicopters are prone to ‘bouncing’ during air turbulence (dependent on undercarriage design), This could require additional airborne checks and increased clearance above the mandated minimum 3 in. from the transport aircraft structure.



Image 1 - Chinook stripped for air transport in a C-17A



Image 2 - Chinook loading into a C-17A

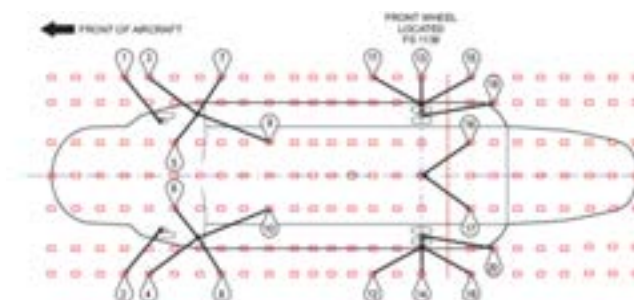

Image 3 - Chinook C17A tie-down scheme plan view

**LEAFLET 5**  
**HELICOPTERS - EVIDENCE FOR JADTEU AIRPORTABILITY ASSESSMENT**

Name

Description

MOD Task Sponsor

Manufacturer

Manufacturer Contact Person

External Dimensions (mm. & in.)

Weight (kg. & lb.) (Prepped for Air Transport Configuration)

Individual Landing Gear Wts (kg. & lb.) (Prepped for Air Transport)

Ancillary Equipment removed for air transport(rotor blades etc)

Date

This leaflet is a guide for the presentation of evidence to JADTEU to gain airportability clearance.

This leaflet should be submitted to JADTEU, with all content considered and signed off by a competent person.

All equipment presented for trial or assessment by JADTEU is to be representative of Theatre Entry Standard or in the configuration that it would be presented for air transport. It should be fully fitted out and at the representative weight that it will be transported.

**DEF-STAN 00-003, SECTION 2, PARA 10**

- |   |   |     |    |
|---|---|-----|----|
| 1 | Has the equipment be designed to comply with Def-Stan 00-003, Section 2, Para 10?<br>As this is an air vehicle it should comply with this Def-Stan 00-003, derived from Def-Stan 970. | Yes | No |
|---|---|-----|----|

**LOAD ATTACHMENT POINTS**

- |   |  |     |    |
|---|--|-----|----|
| 2 | Is the helicopter fitted with bespoke load attachment points to be used for restraining in the transport aircraft? | Yes | No |
|---|--|-----|----|
- 3 State the quantity, type and location of the load attachment points.
- 4 What is the ULTIMATE rating of the load attachment points? (See AP Design Guide Chapter 3).
- 5 What limitations, if any, are there on the angle of the restraint chains from the load attachment points?
- 6 Are the ratings of load attachment points marked on the helicopter adjacent to the load attachment points? Is this the Safe Working Load (SWL) or Ultimate load? What is the safety factor to yield? What is the safety factor to the ultimate tensile stress?

- 7 What is the internal and cross section diameter of the load attachment points? (Refer to Chapter 2, Para 7).
- 8 Are there any locations on the structure that could be used to attach restraint chains?
- 9 If so, what is the **ULTIMATE** rating of the load attachment points on the structure? (i.e can 10 000 lb. or 25 000 lb. chains be attached to the structure).

**LANDING GEAR**

- 10 Can restraint chains be attached to the landing gear?    Yes                      No
- 11 Which landing gear can restraint chains be attached to?
- 12 What is the landing gear rated to when they are used as load attachment points?  
Is this **ULTIMATE** or Safe Working Load?  
**OR**  
How many 25 000 lb. or 10 000 lb. chains can be attached to the landing gear for restraint?

13 Is the landing gear rated to take a 4g vertical down force? (This is an ultimate force, not the designed load. This would be a very low cycle, static load, almost once only event that may occur in the event of an aircraft emergency). Provide the ultimate rated design capacity of each landing gear.

14 What are the individual tyre pressures? (PSI).

**An ATK is also a generic term for the equipment supplied by the consignor required to load and restrain the helicopter.  
This can include load attachment points (i.e shackles), winch bridles, blade restraint kit, etc.**

15 Is an ATK required to load this helicopter? Has this been provided by the manufacturer?

16 Has the ATK been certified by the manufacturer for use as an air transport system for this helicopter?

17 Describe the ATK. Provide drawings/pictures of the ATK.

- 18 Has the ATK been designed to air transport the helicopter in a specific type of transport aircraft?
- 19 Is the ATK attached to the helicopter to meet requirements of Def-Stan 00-003, Section 2, Para 10.8.6?
- 20 Is the ATK fitted with attachment points for winching?
- 21 How is the ATK attached to the helicopter?
- 22 Are the ATK wheels pneumatic or solid? What are the tyre pressures?
- 23 Is the ATK fitted with a brake system?

**GENERAL**

- 24 What is the helicopter publication reference(s) for preparation for air transport? Provide a copy of this reference.

- 25 How is the helicopter steered when winching into the transport aircraft?
  
- 26 What locations on the helicopter can be used to attach a winch to?
  
- 27 When stripped for air transport can the helicopter brake system be used for loading?
  
- 28 Provide details of ancillary equipment that has to be removed for air transport. (weight/dimensions/how they are to be transported).
  
- 29 What is the VERTICAL C of G position of the helicopter when prepped for air transport?
  
- 30 Are there any specific requirements required to cope with differential air pressure (opening of vents, inward/outward relief valves)?

- 31 Is the helicopter complete and at the final build standard?
  
- 32 Are there any specialist operating conditions?
  
- 33 Attach drawings to show the general arrangement, plan view, side elevations and overall dimensions in the air transport configuration?
  
- 34 If possible provide photographs of the helicopter.
  
- 35 Has a different variant been cleared for air transport in UK military aircraft?
  
- 36 Has this helicopter been cleared for airportability in other nation's military aircraft?

**DANGEROUS GOODS (DG) - DG HAS TO BE CLEARED IAW IATA DG REGULATIONS AND DANGEROUS GOODS MANUAL (DGM) CURRENT EDITION.**

- 37 Does the equipment incorporate any permanent magnets or retain any level of magnetic flux after powering down which could interfere with aircraft systems?

38 State the quantity, type and location of any Dangerous Goods (DG). (e.g. Refrigerant, fire extinguishers, batteries fire suppressant, etc.).

39 Attach the Material Safety Data Sheet (MSDS) for all declared DG.

40 Batteries – Describe how all the batteries are isolated? Provide details of the location of isolator switch(es)/circuit breakers.

41 Is the helicopter fitted with a Fire Suppression system? If so, how is it isolated to prevent automatic or manual operation?

**DECLARATION**

To be signed by a competent person.

The person signing below confirms that to the best of their knowledge the details provided in this leaflet are accurate and correct.

Signed:

Name:

Job Title:

Date:

**LEAFLET 6 GROUND SUPPORT EQUIPMENT - EVIDENCE FOR JADTEU AP ASSESSMENT**

**1 Information and advice**

Ground Support Equipment (GSE) is generally not self-powered and can be transported as a palletised load and or loaded to the aircraft floor. The range of sizes and types of GSE is varied; the item could be classed as General Cargo and therefore would not require a specific TDS or TDN. Alternatively, it may be of a size and weight that requires the design and construction of the GSE to encompass airportability criteria in order for it to be loaded and restrained in RAF transport aircraft. In such cases JADTEU advice and trials will be required. Non-powered GSE will normally require winching into the aircraft and load attachment points fitted suitable for the aircraft restraint chains.

It is preferable for GSE to be equipped with pneumatic tyres (less than 100 PSI – 6.9 bar), fitted with 2 winch attachment points and sufficient load attachment points to attach aircraft restraint chains. It must be constructed to meet the requirements of Def-Stan 00-003, Section 2, Para 10, so any items (e.g. Engine,) fitted are sufficiently secure so they will not breakaway if subjected to the ‘g’ forces quoted in Def-Stan 00-003 Section 2, Para 10.

When submitting a JADTEU Task application for GSE this leaflet should be completed to allow an airportability assessment to be carried out.



**Liquid Cooling Cart (LCC)  
Cooling Trolley**  
- OFFSET

- 10 x 10 000 lb. chains and tensioners.
- 1 x 5000 lb. ratchet strops.
- Sleeper shoring
- 6 x (22 in. x 10 in. x 2 in.).
- 2 x (22 in. x 10 in. x 3/4 in.) shim.
- 2 x (22 in. x 10 in. x 1/4 in.) shim.
- 2 x 9 degree toe ramp extensions & blocks.

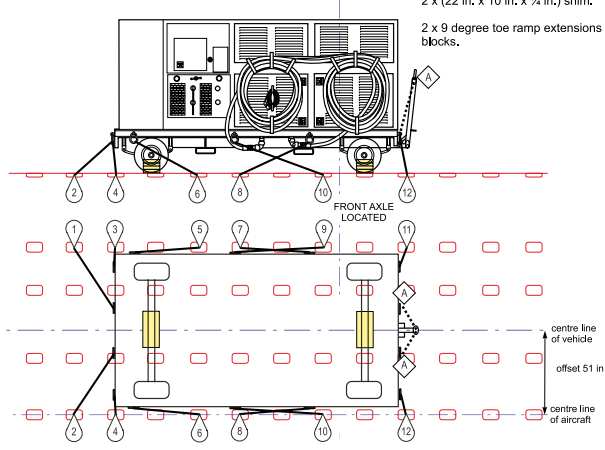

Image 1 - Liquid cooling cart in the C-17A mock up - offset, and TDS



Image 2 - Aircraft jack in a C-17A - loaded on pallets

**LEAFLET 6**  
**GROUND SUPPORT EQUIPMENT - EVIDENCE FOR JADTEU AP ASSESSMENT**

GSE Name

GSE Description

NSN

EAC

GEMS

MOD Task Sponsor

Manufacturer

Manufacture Contact Person

External Dimensions (mm. & in.)

Weight (kg. & lb.) (Prepped for Air Transport Configuration)

Individual Axle Wts (kg. & lb.) (Prepped for Air Transport)

Jockey Wheel Wt (kg. & lb.) (Prepped for Air Transport)

Max AUW (kg. & lb.)

Individual Max Axle Wts (kg. & lb.)

Date

This leaflet is a guide for the presentation of evidence to JADTEU to gain airportability clearance. This leaflet should be submitted to JADTEU, with all content considered and signed off by a competent person. All equipment presented for trial or assessment by JADTEU is to be representative of Theatre Entry Standard or in the configuration that it would be presented for air transport. It should be fully fitted out and at the representative weight that it will be transported.

**DEF-STAN 00-003, SECTION 2, PARA 10**

1 Has the equipment been designed to comply with Def-Stan 00-003, Section 2, Para 10?      Yes                      No

**LOAD ATTACHMENT POINTS**

2 Is the GSE fitted with bespoke load attachment points to be used for restraining the trailer in an aircraft?      Yes                      No

3 State the quantity, type and location of the load attachment points.

4 What is the ULTIMATE rating of the load attachment points? (See AP Design Guide Chapter 3)

5 What limitations, if any, are there on the angle of restraint chains from the load attachment points?

6 Are the ratings of load attachment points marked on the GSE adjacent to the load attachment points?  
 Is this the Safe Working Load (SWL) or Ultimate Load?  
 What is the safety factor to yield?  
 What is the safety factor to the ultimate tensile stress?

7 Is there any structure that could be used to attach restraint chains? (tow bar, framework etc).  
 If so, what is the ULTIMATE rating? (i.e. can 10 000 lb. or 25 000 lb. chains be attached to the structure).

**WINCHING POINTS**

- 8 Is the GSE fitted with winching points?      Yes                      No
- 9 If there are no winch points is there a location on the GSE to attach chains/chain bridle, (i.e. structure/axles)?      Yes                      No
- 10 What is the rating of the winch points?
- 11 What is the location and quantity of the winch points? (Generally a minimum of 2 locations is required at the rear of the trailer).
- 12 Are the points identified as winch points?
- 13 What is the internal diameter of the winch points?

**AXLES/TYRES**

- 14 Can restraint chains be attached to the axles?      Yes                      No
- 15 Which axles can restraint chains be attached to?

- 16 How many chains (25 000 lb. or 10 000 lb.) can be attached to the axles for restraint?  
(e.g. Front Axle - 2 x 25 000 lb. chains in the forward and aft direction. Rear Axle - 2 x 25 000 lb. chains in one direction only).
- 17 Are the axles rated to take a 4g vertical down force? (This is an ultimate force, not the designed load. This would be a very low cycle, static load, almost once only event that may occur in the event of an aircraft emergency).
- 18 If tyres are pneumatic, what are the tyre pressures?
- 19 If the tyres are solid, state the following.
- |  | Diameter (in.) | Contact width (in.) | Material (Rubber/metal etc) |
|--|----------------|---------------------|-----------------------------|
|--|----------------|---------------------|-----------------------------|

**GENERAL**

- 20 Is there a GEMS Leaflet? If so, please include details.

- 21 Describe the type of tow bar. (Swan neck, NATO Standard towing eye, etc).
- 22 Is the GSE equipped with stabiliser legs? Are these rated to 4g down?
- 23 In simple terms describe how to operate the brake system.  
Do the brakes require air pressure to operate?  
How many brake operations are there when the air tank is fully charged?  
Do the brakes lock on if the air pressure is dissipated?  
Can the brakes be mechanically released in the event of the air pressure discharging?  
If applicable, describe how the brakes can be mechanically released.

24 Internal Equipment.

Is all internal equipment exceeding a mass of 23 kg (50 lb.) positively restrained or contained to meet the load factors of Def Stan 00-003, Section 2, Para 10.8.6 (3g fwd, 1.5g lateral, 2g up, 1.5g aft and 4g down)? (Note: all internal equipment must be restrained or contained). **Provide evidence to show how all internal equipment exceeding a mass of 23 kg. (50 lb.) (e.g Wheel Jack, Weapon System, Sand Ramps, Jerry Cans) are restrained or contained to meet the load factors of Def Stan 00-003, Section 2, Para 10.8.6 (3g fwd, 1.5g lateral, 2g up, 1.5g aft and 4g down)?.**

25 What is the VERTICAL C of G position of the GSE?

26 Is there any aspect of the equipment that could present a hazard because of differential air pressure conditions – as detailed in Def-Stan 00-003, Section 2, Para 10.11.?



- 33 Has a different variant been cleared for air transport in UK military aircraft?
- 34 Has this GSE been cleared for airportability in other nation's military aircraft?
- 35 Provide details of equipment mounted on the GSE (generators, boxes, boat).
- 36 Is the equipment listed at line 35 positively restrained to meet the load factors of Def Stan 00-03, Section 2, Para 10.8.6 (3g fwd, 1.5g lateral, 2g up, 1.5g aft and 4g down)?  
**Provide evidence to show how any external equipment is restrained to meet the requirements of Def Stan 00-03, Section 2, Para 10.8.6 (3g fwd, 1.5g lateral, 2g up, 1.5g aft and 4g down)?**

**DANGEROUS GOODS (DG) - DG HAS TO BE CLEARED IAW IATA DG REGULATIONS AND DANGEROUS GOODS MANUAL (DGM) CURRENT EDITION.**

- 37 Does the equipment incorporate any permanent magnets or retain any level of magnetic flux after powering down which could interfere with aircraft systems?

- 38 State the quantity, type and location of any Dangerous Goods (DG). (e.g. Refrigerant, fire extinguishers, batteries fire suppressant etc).
- 39 Attach the Material Safety Data Sheet (MSDS) for all declared DG.
- 40 Batteries – Is there an Uninterrupted Power Supply (UPS) system?
- 41 Batteries – How are they isolated – location of isolator switch (es).

## **DECLARATION**

To be signed by a competent person.

The person signing below confirms that to the best of their knowledge the details provided in this leaflet are accurate and correct.

Signed:

Name:

Job Title:

Date:

**LEAFLET 7 ISO CONTAINERS, CABINS AND CONTAINERS**

**1 Pallets**

ISO Containers and cabins are normally transported on linked 463L air cargo pallets. The number of pallets depends on the size of the ISO Container/cabin. For example a 20 ft. x 8 ft. x 8 ft. ISO requires 3 linked 463L pallets (in 108 in. width). The ISO Container/cabin is located on the pallets and is secured in the aircraft with chains and tensioners to the aircraft floor points; the pallet is secured independently to the aircraft integral rail system. This method requires a transfer loader to load the ISO Container/cabin located on the linked air cargo pallets into the aircraft. The RAF currently uses an AMSS Atlas Loader; this can handle up to 4 linked air cargo pallets. Transfer loaders at civilian airports are normally only capable of handling 2 linked air cargo pallets (therefore limiting the size of the ISO Container/cabin).

**2 Wheeled mobilisers**

ISO Containers and cabins can also be fitted with wheeled mobilisers (provided by the user unit). This allows them to be loaded without the use of a transfer loader and they can be located on the aircraft floor negating the requirement to use air cargo pallets. This method would aid operations at austere locations or civilian airports. There are different types of mobilisers on the market, they are to be provided by the Sponsor of the equipment and have to be assessed by JADTEU for airportability with the ISO Container/cabin.

**3 Shoring**

The ISO Container/Cabin is normally located on 10 in. wide and 2 in. high shoring (wooden planks) that runs the length of the base under the outer beams. The ISO container/cabin must have sufficient flat areas on the base to allow it to be located on air cargo pallets without exceeding the load limitations of the air cargo pallet or aircraft rollers.

**4 Internal and external equipment**

Internal and external equipment fitted to or inside the container must be positively restrained or contained to meet the static ultimate safety factors quoted in Def-Stan 00-003, Section 10 (Para 10.8.6). This can be achieved by various means, such as mechanical attachment or by using restraint devices attached to suitably rated load attachment points. The regulations applicable to ISO containers regarding internal restraint and DG are also applicable to cabins. Evidence will be required to prove the equipment is sufficiently restrained.

**5 Maximum dimensions and weights**

The standard maximum dimensions and weights for ISO Containers/Cabins that have been cleared by JADTEU are:

<b>Aircraft</b>	<b>Height</b>	<b>Width</b>	<b>Length</b>	<b>Weight Limit Length up to 120 in.</b>	<b>Weight Limit Length 121 to 360 in.</b>	<b>Remarks</b>
A400M	2591 mm. (102 in.)	2438 mm. (96 in.)	6096 mm. (240 in.)	See Remarks	See Remarks	Max weight of a 6096 mm. (L) ISO is 16 500 kg.
C-17A	119 in. (3022 mm.)	96 in. (2438 mm.)	360 in. (9144 mm.)	10 000 lb. (4535 kg.)	36 375 lb. (16 499 kg.)	Note: It can be possible to load ISO containers/cabins up to 40 ft. in length – JADTEU can advise

## 6 ISO containers and cabins that exceed

It may be possible to clear ISO containers and cabins that exceed by a small margin the above dimensions and weights, this will depend on many factors (e.g construction, weight, weight distribution, quantity, location and rating of tie down points.). Generally if the ISO Container/Cabin is within the above limitations it will not require a loading assessment.

## 7 ISO corners

An ISO container is restrained using the ISO corners. ISOs or Cabins may not have compliant ISO corners (See ISO standards below) , if not they should be fitted with sufficient rated load attachment points (JADTEU will advise). JADTEU will require evidence that they have been built to ISO standards. The following information is available for ISO containers/cabins:

- 7.1 ISO Build Standards:
- ISO 668:2020. - Series 1 Freight Containers - Classification, dimensions and ratings.
  - ISO 1161:2016 - Series 1 Freight Containers - Corner and Intermediate Fittings - Specifications.
  - ISO 1496-3:2019 - Series 1 Freight Containers - Specification and Testing.

## 8 MOD ISOs

The MOD policy publication for ISO containers is the JSP 800, Vol 6 – Container Management Regulations. JSP 800 Vol 3 (Movement of Materiel) by Container promotes the key safety considerations relevant to loading and unloading materiel for movement by container.

## 9 Dangerous Goods (DG)

If Dangerous Goods (DG) are to be carried inside the ISO Container/Cabin refer to the IATA (Dangerous Goods by Air Regulations), Dangerous Goods Manual (DGM) Current Edition and/or contact Defence Safety Authority - Movement and Transport Safety Regulator (Defence Air Freight) - SO2 Air-Dangerous Goods Safety Advisor (Air-DG Safety Advisor), HQ Air, Hurricane Block, RAF High Wycombe, for advice.

## 10 Mobilisers

ISO Containers/Cabins fitted with mobilisers. The following applies:

- 10.1 They should be capable of being winched up and down the applicable aircraft ramp incline.
- 10.2 Are they attached to the cabin/container with sufficient strength to be considered a unitised load?  
– If not the mobilisers and cabin/container will be restrained separately.
- 10.3 Provision (i.e. fitted/identified load attachment points) should be made to allow the cabin/container and mobilisers to be restrained separately.
- 10.4 Winch attachment points will be required on the mobilisers.

## CONTAINERS (E.G. MISSILES OR UAVS)

### 11 Pallets

Containers (e.g. for missiles or UAVs) should be designed and manufactured to be airortable in RAF Air Transport aircraft to meet the requirements of Def-Stan 00-003 Section 2, Para 10 and JADTEU. They will normally be transported on 463L air cargo pallets (108 in. x 88 in.) and may be secured to the air cargo pallet(s) using chains and tensioners (restraint devices) or air cargo nets. The method of restraint will depend on the size and design of the container. If the container cannot be transported on 463L air cargo pallets it will require a wheeled mobiliser system to be provided and fitted by the container owner (Delivery Team).

The container should be able to fit on to 463L air cargo pallets. These can be linked into pallet trains, up to 4 pallets in length.

## 12 Internal and external equipment

Internal and external equipment fitted to or inside the container must be positively restrained or contained to meet the static ultimate safety factors quoted in Def-Stan 00-003, Section 2, (Para 10.8.6). This can be achieved by various means, such as mechanical attachment or by using restraint devices attached to suitably rated load attachment points. Evidence will be required to prove the equipment is sufficiently restrained.

Equipment secured inside a container such as UAVs may require a fuel venting system to vent outside of the container.

## 13 Restraint of container using Load Attachment Points

Design considerations for a container that is to be restrained using restraint devices are:

- 13.1 The container must be fitted with sufficient load attachment points (LAPs) to attach sufficient restraint devices to achieve the minimum restraint of the container in compliance with Def-Stan 00-003, Section 10.
- 13.2 The LAPs must be located in suitable locations on the container to permit access from the tie down point to the air cargo pallet tie down rings and/or aircraft floor tie down points.
- 13.3 The LAPs must be rated to a minimum of 10 000 lb. (ULTIMATE) in all directions.
- 13.4 The LAPs must be capable of accepting restraint chains or ratchet stops.

## 14 Restraint using Air Cargo Nets

Design considerations for a container that is to be restrained using air cargo nets are:

- 14.1 The mass of the container (including contents) cannot exceed 4535 kg. (10 000 lb.).
- 14.2 The dimensions of the container must be within the dimensional limits of the air cargo net (JADTEU will advise).
- 14.3 The container height must not exceed 96 in. This will be reduced if shoring is required between the container and air cargo pallet.
- 14.4 The structure of the container must be capable of accepting the loads imparted by an air cargo net that will be tensioned over it to restrain it to the air cargo pallet(s).
- 14.5 LAPs should be fitted to permit the attachment of safety chains/strops.

Provision (i.e. fitted/identified LAPs) should be made to allow the cabin/container and mobilisers to be restrained separately.



Image 1 & 2 - 20 ft. ISO Container located on 463L air cargo pallets being loaded using an Atlas Transfer Loader.

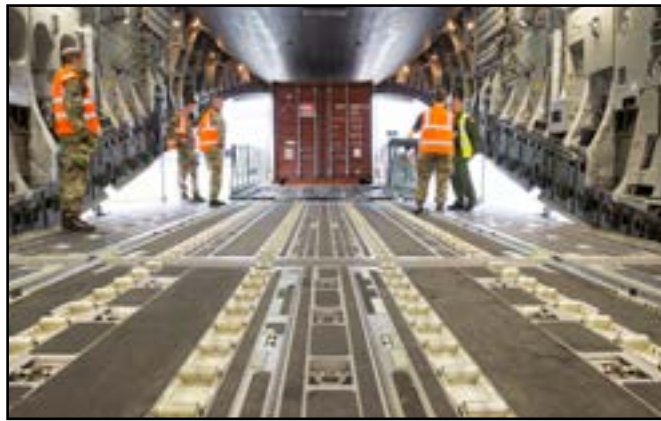

Image 3 & 4 - Transferring a 20 ft. ISO Container located on 463L air cargo pallet onto the C-17A - rollers configured for ADS.



Image 5 & 6 - 20 ft. ISO Container is pushed on, with cabin floor rollers and side guidance in the ADS configuration. The ISO is safety chained to the air cargo pallets at this stage.



Image 7 - 20 ft. ISO Container viewed looking aft. It is restrained to the cabin floor using aircraft chains. The air cargo pallets are locked into the side guidance system.

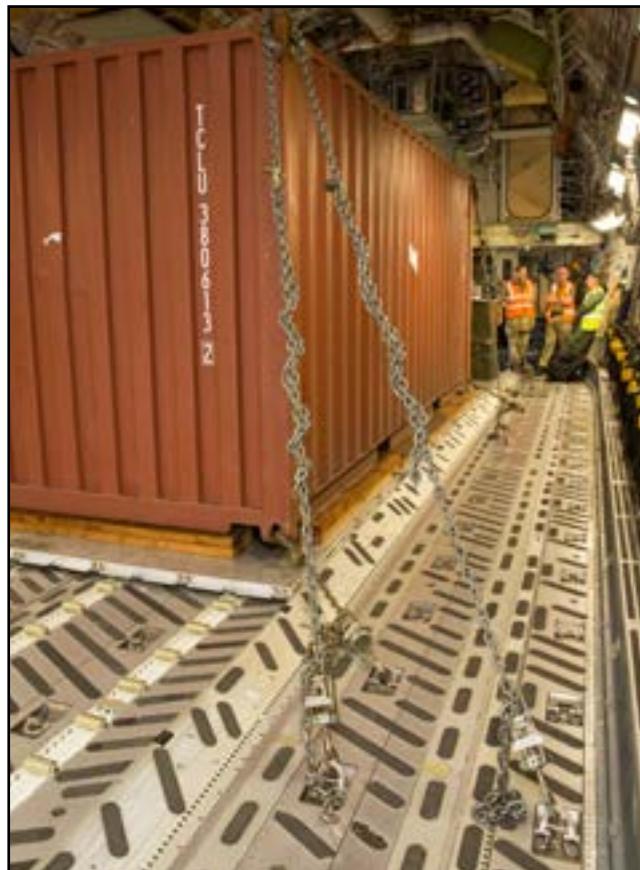

Image 8 - 20 ft. ISO container viewed looking forward



Image 9 - Cabin on mobilisers - to be winched into a C-17A



Image 10 - Cabin on mobilisers - Located and restrained by chains and tensioners inside a C-17A



Image 11 - Missile containers restrained to 2 x linked 463L air cargo pallets using chains and tensioners



Image 12 - UAV container positioned inside a C-17A - located on linked air cargo pallets, restrained to the aircraft floor from load attachment points on the container

**LEAFLET 7**  
**ISO CONTAINER, CABIN AND CONTAINERS**  
**EVIDENCE FOR JADTEU AIRPORTABILITY ASSESSMENT**

Equipment Name

Equipment Description

MOD Task Sponsor

External Dimensions (in.)

Weight (Air Transport Configuration) (lb.)

Manufacturer

Date

This leaflet is a guide for the presentation of evidence to JADTEU to gain airportability clearance.

This leaflet should be submitted to JADTEU, with all content considered and signed off by a competent person. Fill in the details for either ISO Containers/Cabins (Para's 1 to 13 and 31 to 50) or Containers (Para's 14 to 50).

All equipment presented for trial or assessment by JADTEU is to be representative of Theatre Entry Standard or in the configuration that it would be presented for air transport. It should be packed and be fully fitted out and at the representative weight that it will be transported.

**ISO CONTAINERS AND CABINS DEF-STAN 00-003, SECTION 10**

- 1 Has the equipment been designed to comply with Def-Stan 00-003, Section 2, Para 10?
  
- 2 Is the container certified with an in date Convention for Safe Containers (CSC) plate.  
NOTE: Containers cannot be air transported without an in date CSC plate.
  
- 3 Is the container fitted with standard ISO corners compliant with the build standard of ISO containers?  
ISO 668:2020. - Series 1 Freight Containers - Classification, dimensions and ratings.  
ISO 1161:2016 - Series 1 Freight Containers - Corner and Intermediate Fittings - Specifications.
  
- 4 Is the container fitted with external load attachment points other than ISO corners?
  
- 5 Is the structure between the ISO corners/load attachment points capable of withstanding the tensile and compressive forces imparted by restraint chains/strops? (The structure should at least match the rating of the ISO corners/load attachment points).

- 6 If fitted, what is the ultimate rating of the load attachment points – and in what direction?
- 7 If fitted, state the number and type of load attachment points.
- 8 If fitted, are the load attachment points ratings marked next to the tie down points?  
Is this the SWL or Ultimate load?
- 9 Internal Equipment.  
Is all internal equipment exceeding a mass of 23 kg. (50 lb.) positively restrained or contained to meet the load factors of Def Stan 00-003, Section 2, Para 10.8.6 (3g fwd, 1.5g lateral, 2g up, 1.5g aft and 4g down)?  
(Note: all internal equipment must be restrained or contained).  
**Provide evidence to show how all internal equipment exceeding a mass of 23 kg. (50 lb.) (e.g Internal Racking, Air Conditioning Units, Internal Generators, Filing Cabinets) are restrained or contained to meet the load factors of Def Stan 00-003, Section 2, Para 10.8.6 (3g fwd, 1.5g lateral, 2g up, 1.5g aft and 4g down)?**
- 10 External Equipment.  
Is all external equipment positively restrained to meet the load factors of Def Stan 00-03, Section 2, Para 10.8.6 (3g fwd, 1.5g lateral, 2g up, 1.5g aft and 4g down)?  
**Provide evidence to show how any external equipment is restrained to meet the requirements of Def Stan 00-003, Section 2, Para 10.8.6 (3g fwd, 1.5g lateral, 2g up, 1.5g aft and 4g down)?**
- 11 Are installations installed above the floor (i.e. Air Conditioning Units) restrained to the requirements of Def-Stan 00-003, Section 2, Para 10.8.6 (including 4G vertical down)? **Provide evidence.**
- 12 What is the maximum permitted all up weight of the ISO container/cabin.

- 13 What is the C of G position (X and Y)?
- 14 Is there any aspect of the equipment that could present a hazard because of differential air pressure conditions – as detailed in Def-Stan 00-003, Section 2, Para 10.11.?
- 15 Are there any specific requirements required to cope with differential air pressure (opening off vents, inward/outward relief valves)?

**CONTAINERS OTHER THAN ISO TYPE CABINS (E.G. MISSILE OR UAV CONTAINERS)  
DEF-STAN 00-003 SECTION 10**

- 16 Has the container been designed to comply with Def-Stan 00-003, Section 2, Para 10?
- 17 Is the container fitted with external load attachment points?
- 18 Describe the load attachment points (e.g fixed ring, rotating shackle, RUDD shackles etc).
- 19 What is the ultimate rating of the load attachment points? (Should be no less than 7500 lb.).
- 20 Are there any angle limitations for the load attachment points (ideally there should be no limitation).
- 21 State the quantity and type of load attachment points.
- 22 Are the load attachment point ratings marked next to the tie down points?  
Is this the SWL or Ultimate load?
- 23 Are there other locations on the container of known strength that can be used as load attachment points?

- 24 If so, what is the ultimate rating of the load attachment points?
- 25 Are all load contents and all externally mounted installations, exceeding a mass of 23 kg. positively restrained or contained to the requirements of Def-Stan 00-003, Section 2, Para 10.8.6 (3g fwd, 1.5g lateral, 2g up, 1.5g aft and 4g down)?  
Provide evidence to show how all internal load contents and externally mounted installations exceeding a mass of 23 kg. (e.g UAV Fuselage, UAV Engine, etc) are restrained to the requirements of Def-Stan 00-003, Section 2, Para 10.8.6 (3g fwd, 1.5g lateral, 2g up, 1.5g aft and 4g down)?.
- 26 Does the container have sufficient strength to support the loads applied by an air cargo net for restraint?
- 27 Can the container be stacked for air transport (the container will have to support the weight of the stacked of the container to meet a 4g ultimate down force)?
- 28 Is there any limitation on the direction of travel? If so what is it?
- 29 Can the container be located on an aircraft ramp for air transport?
- 30 What is the C of G position (X and Y)?
- 31 Is there any aspect of the equipment that could present a hazard because of differential air pressure conditions – as detailed in Def-Stan 00-003, Section 2, Para 10.11.?
- 32 Are there any specific requirements required to cope with differential air pressure (opening off vents, inward/outward relief valves)?

## GENERAL

- 33 Is the equipment complete and at the final build standard?
- 34 Are drawings attached to show the general arrangement, plan view, side elevations and overall dimensions in the air transport configuration?
- 35 Is the outside of the ISO/Cabin/Container clean and without external protrusions that may add to the external dimensions or impede access to restraint chains?

- 36 If applicable, describe any external protrusions.
  
- 37 Is the equipment designed to be DROPS compatible?
  
- 38 Is it fitted with forklift apertures?
  
- 39 Can it be lifted by a crane?
  
- 40 State the number and type of available lifting points.
  
- 41 Are the locations of each lifting point identified?
  
- 42 Is the container to be air transported using mobilisers?
  
- 43 What type of mobilisers are to be fitted?
  
- 44 If mobilisers are fitted attach details and seek advice from JADTEU.
  
- 45 Does the internal design provide satisfactory stowage positions and load attachment points for GFE items.
  
- 46 Does the internal design allow stowage boxes to be secured internally to meet the requirements of Def-Stan 00-003, Section 2, Para 10.8.6 (3g fwd, 1.5g lateral, 2g up, 1.5g aft and 4g down)?
  
- 47 What is the ultimate rating (or SWL) of internal load attachment points?  
How many internal LAP(s) are fitted? Where are they located?
  
- 48 Are there any specialist operating conditions? If so, provide details.

**DANGEROUS GOODS - (DG) DG HAS TO BE CLEARED IAW IATA DG REGULATIONS AND DANGEROUS GOODS MANUAL (DGM) CURRENT EDITION.**

49 Does the equipment incorporate any permanent magnets or retain any level of magnetic flux after powering down which could interfere with aircraft systems?

50 State the quantity, type and location of any DG, (e.g. Refrigerant, fire extinguishers, batteries etc.).

51 Attach the MSDS for all declared DG.

52 Batteries – Is there a UPS system?

53 Batteries – How are they isolated – location of isolator switch(es).

**DECLARATION**

To be signed by a competent person.

The person signing below confirms that to the best of their knowledge the details provided in this leaflet are accurate and correct.

Signed:

Name:

Job Title:

Date:

## LEAFLET 8 MARINE CRAFT

### 1 Air Transporting Marine Craft – General Information

Marine Craft will normally be mounted onto a trailer for air transport. When considering air transport of a Craft the manufacturer must ensure the trailer is suitable for air transport with the Craft mounted on it. The trailer will be winched into the aircraft, with the tow bar facing aft. Alternatively, it may be possible to load the trailer connected to a prime mover. Ideally, the Craft will be secured to the trailer (in compliance with Def Stan 00-003, Section 2, Para 10). The trailer will then be restrained to the aircraft floor using the applicable aircraft restraint devices. The manufacturer can also design the Craft and trailer so they can be restrained separately in the aircraft.



Image 1 Craft Restrained to Andover Trailer in the C-17A Cargo Hold Mock-Up.

### 2 Major Airportability design considerations are:

- 2.1 The Craft will require Load Attachment Points (LAPs) to be fitted to restrain the Craft to the trailer and/or aircraft floor.
- 2.2 If the Craft is to be restrained to the aircraft floor the LAPs must be capable of accepting the different aircraft restraint devices (each aircraft uses different restraint devices).
- 2.3 If the Craft is restrained to a trailer (with no restraint to the aircraft floor), the LAPs can be designed to fit and use restraint devices supplied by the manufacturer.
- 2.4 There must be enough, suitably located LAPs to restrain the Craft in accordance with restraint requirements in Def Stan 00-003, Section 2, Para 10.
- 2.5 If the Craft is to be restrained to the aircraft floor the manufacturer must consider the following:
  - 2.5.1 Access from the Craft LAPs to the aircraft floor tie down points – will the trailer interfere with the routing of the restraint devices?
  - 2.5.2 The pattern of the floor tie down points is different on each aircraft, this may affect the design, or positioning of the trailer and Craft LAPs.
- 2.6 The Craft will normally be reversed into the aircraft (stern first). The LAPs must be located on the Craft so that in this configuration sufficient restraint can be achieved.
- 2.7 The dimensions of the Craft mounted on the trailer must be within the internal dimensions of the aircraft cabin.
- 2.8 The Craft hull must be capable of sustaining a 4g down force, mounted on the trailer, without failure.

**LEAFLET 8**  
**MARINE CRAFT - EVIDENCE FOR JADTEU AIRPORTABILITY ASSESSMENT**

**Marine Craft Name**

Description

NSN

Manufacturer

Manufacturer Contact Person

External Dimensions (mm. & in.)

Weight (kg. & lb.) (Prepped for Air Transport)

**CONTINUE ON NEXT PAGE**

**Trailer Name**

Description

NSN

Manufacturer

Manufacturer Contact

External Dimensions (mm. & in.)

Axle/Jockey Wheel Weights (kg. & lb.) (Prepped for Air Transport)

Trailer Leaflet 4 completed?    Yes                      No

Marine Craft on Trailer - External Dimensions (mm. & in.)

Axle and Jockey Weights (kg. & lb.) (Prepped for Air Transport)

MOD Task Sponsor

Date

This leaflet is a guide for the presentation of evidence to JADTEU to gain airportability clearance.

This leaflet should be submitted to JADTEU, with all content considered and signed off by a competent person.

All equipment presented for trial or assessment by JADTEU is to be representative of Theatre Entry Standard or in the configuration that it would be presented for air transport. It should be fully fitted out and at the representative weight that it will be transported.

**DEF-STAN 00-003, SECTION 2, PARA 10**

1 Has the equipment been designed to comply with Def-Stan 00-003, Section 2, Para 10?      Yes                      No

**LOAD ATTACHMENT POINTS (LAPS)**

2 Is the Craft fitted with suitable LAPS to be used for restraining the Craft in an aircraft?      Yes                      No

3 State the quantity, type and location of the LAPS.

4 What is the ULTIMATE rating of the LAPS? (Refer to AP Design Guide, Chapter 3)

5 What limitations, if any, are there on the LAPS? For example, angle limitations.

6 Are the ratings of LAPS marked on the Craft adjacent to the LAPS? Is this the Safe Working Load (SWL) or Ultimate load? What is the safety factor to yield? What is the safety factor to the ultimate tensile stress?

- 7 What is the internal and cross section diameter of the LAPs? (Refer to Chapter 2, Para 18).  
Do the minimum dimensions of the LAPs comply with ATP 3.3.4.1 - Chapter 7 dimensions? (Refer to AP Design Guide Chapter 2, Para 7). If not, provide the dimensions.
  
- 8 Are there any locations on the Craft structure that could be used to attach restraint chains or ratchet strops?
  
- 9 If so, what is the **ULTIMATE** rating of the points on the structure? (i.e can 5000 lb.,10 000 lb. or 25 000 lb. chains or ratchet strops be attached to the structure).
  
- 10 Deck Tie Down Points - What are the SWL and **ULTIMATE** ratings of any deck tie down points (if applicable).
  
- 11 Deck Tie Down Points - What are the quantity and location of any deck tie down points.

## GENERAL

### 12 Equipment fitted to the Craft

Is all equipment exceeding a mass of 23 kg. (50 lb.) positively attached, restrained or contained to meet the load factors of Def Stan 00-003, Section 2, Para 10.8.6 (3g fwd, 1.5g lateral, 2g up, 1.5g aft and 4g down)? (3g fwd, 1.5g lateral, 2g up, 1.5g aft and 4g down)?

(Note: all equipment fitted to the Craft must be attached, restrained or contained).

**Provide evidence to show how all equipment exceeding a mass of 23 kg. (50 lb.) (e.g. Lowered aerial mast, Weapon System, Seats) are attached, restrained or contained to meet the load factors of Def Stan 00-003, Section 2, Para 10.8.6 (3g fwd, 1.5g lateral, 2g up, 1.5g aft and 4g down)? (3g fwd, 1.5g lateral, 2g up, 1.5g aft and 4g down)?**

13 What is the VERTICAL C of G position of the Craft when located on the trailer?

14 Is there any aspect of the equipment that could present a hazard because of differential air pressure conditions – as detailed in Def-Stan 00-003, Section 2, Para 10.11?

15 Are there any specific requirements required to cope with differential air pressure (e.g. RHIB - deflating of float chambers, inward/outward relief valves)?

- 16 Is the Craft complete and at the final build standard?
- 17 Are there any specialist operating conditions? (e.g Does the mast need to be lowered and secured for air transport?).
- 18 Attach drawings to show the general arrangement, plan view, side elevations and overall dimensions in the air transport configuration with the Craft mounted on the trailer.
- 19 If possible, provide photographs of the Craft and trailer.
- 20 Has a different variant of the Craft and/or trailer been cleared for air transport in UK military aircraft?
- 21 Has this Craft and trailer been cleared for airportability in other nation's military aircraft? If so, provide details.

**DANGEROUS GOODS (DG) - DG HAS TO BE CLEARED IAW IATA DG REGULATIONS AND DANGEROUS GOODS MANUAL (DGM) CURRENT EDITION.**

- 22 Does the Craft incorporate any permanent magnets or retain any level of magnetic flux after powering down which could interfere with aircraft systems?

- 23 State the quantity, type and location of any DG. (e.g. Refrigerant gas, fire extinguishers, nitrogen inflation cylinders etc).
- 24 Batteries – Describe how they are isolated.
- 25 Batteries – Identify the type, quantity and location.
- 26 Fuel System – Location, type and total capacity of the fuel tank(s). A fuel tank cannot be above  $\frac{3}{4}$  full for air transport.
- 27 Fuel System – Provide details on how the fuel system operates. How are the fuel contents checked?
- 28 Fire Suppressant System (FSS) – Is the Craft fitted with a FSS?      Yes                      No
- 29 FSS – Identify the components of the FSS and where they are located.
- 30 FSS – How is the FSS isolated to prevent manual or automatic operation. (Mandatory requirement for air transport).

**31 Attach the Material Safety Data Sheet (MSDS) for all declared DG.**

**DECLARATION**

To be signed by a competent person.

The person signing below confirms that to the best of their knowledge the details provided in this leaflet are accurate and correct.

Signed:

Name:

Job Title:

Date:

**ANNEXES**

**CONTENTS**

Subject	Annex
MERLIN HC MK 4/4A DATA SHEET .....	ANNEX A
CHINOOK ALL MKS DATA SHEET .....	ANNEX B1
CHINOOK ALL MARKS CABIN BALLISTIC PROTECTION .....	ANNEX B2
CHINOOK ALL MARKS CABIN BALLISTIC PROTECTION .....	ANNEX B3
C-17A GLOBEMASTER DATA SHEET .....	ANNEX C
A400M DATA SHEET .....	ANNEX D

MERLIN HC MK 4/4A DATA SHEET

ANNEX A

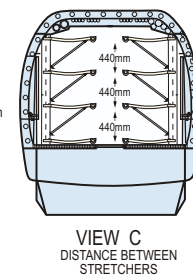
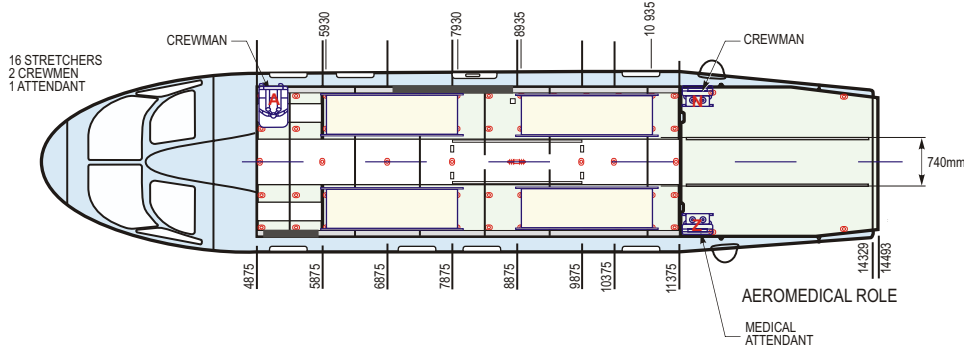
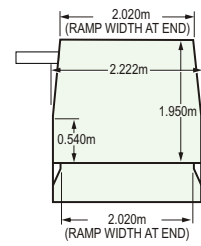
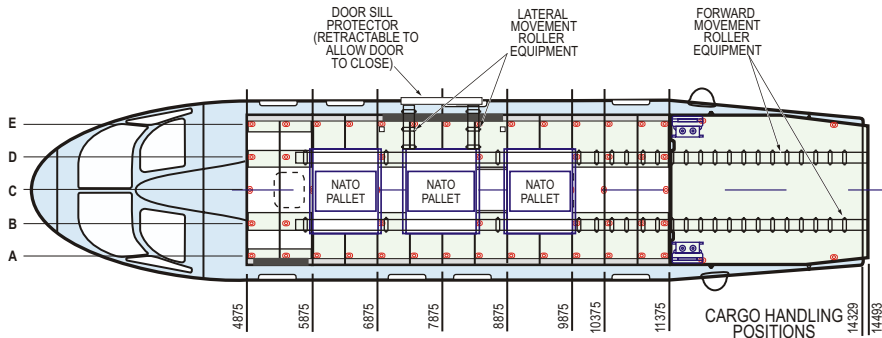
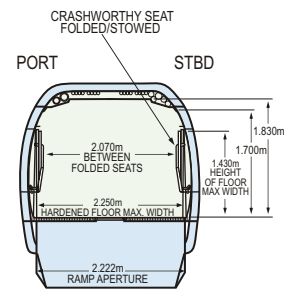
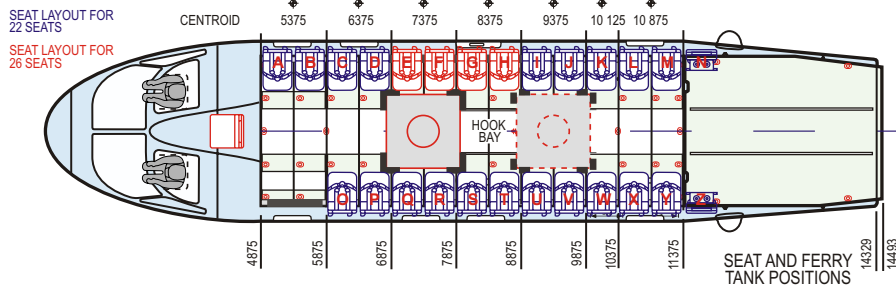
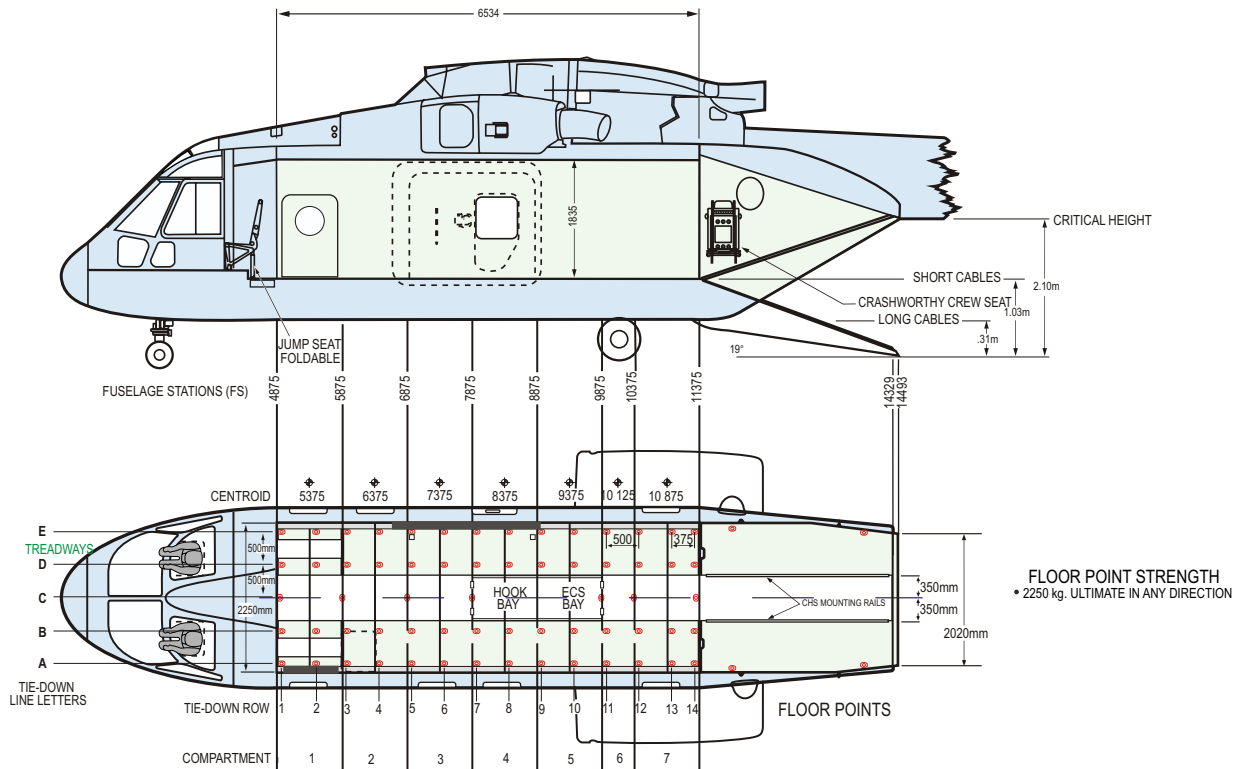

MERLIN HC MK 3/4 DATA SHEET

ANNEX A

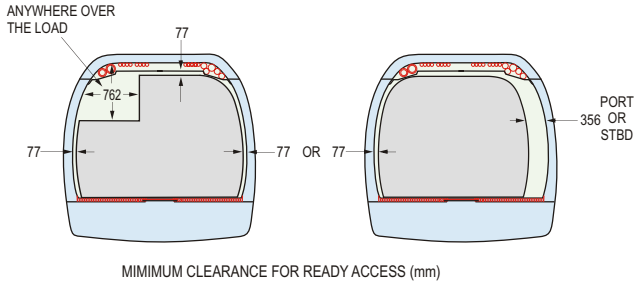

FLOOR LOADING

TREADWAYS: (COMPARTMENT 2 - 7)  
EACH CONCENTRATED LOAD NOT TO EXCEED ... 3.37 kg/sq cm  
(up to a maximum area of 329 sq cm)

REMAINDER OF CABIN FLOOR:  
EACH CONCENTRATED LOAD NOT TO EXCEED ..... 1.50 kg/sq cm  
(up to a maximum area of 67.5 sq cm)

UD LOADING OF MAIN CABIN FLOOR:  
ALL AREAS NOT TO EXCEED ... 1460 kg/sq m

COMPARTMENT LOADING  
LOAD IN A SINGLE COMPARTMENT NOT TO EXCEED ... 1850 kg.

RAMP LOADING  
REFER TO TOPIC 11D

CAPACITIES  
MAXIMUM NUMBER OF SEATS AVAILABLE 24 + 2 CREWMEN  
Wheel axle weight 1850kg.

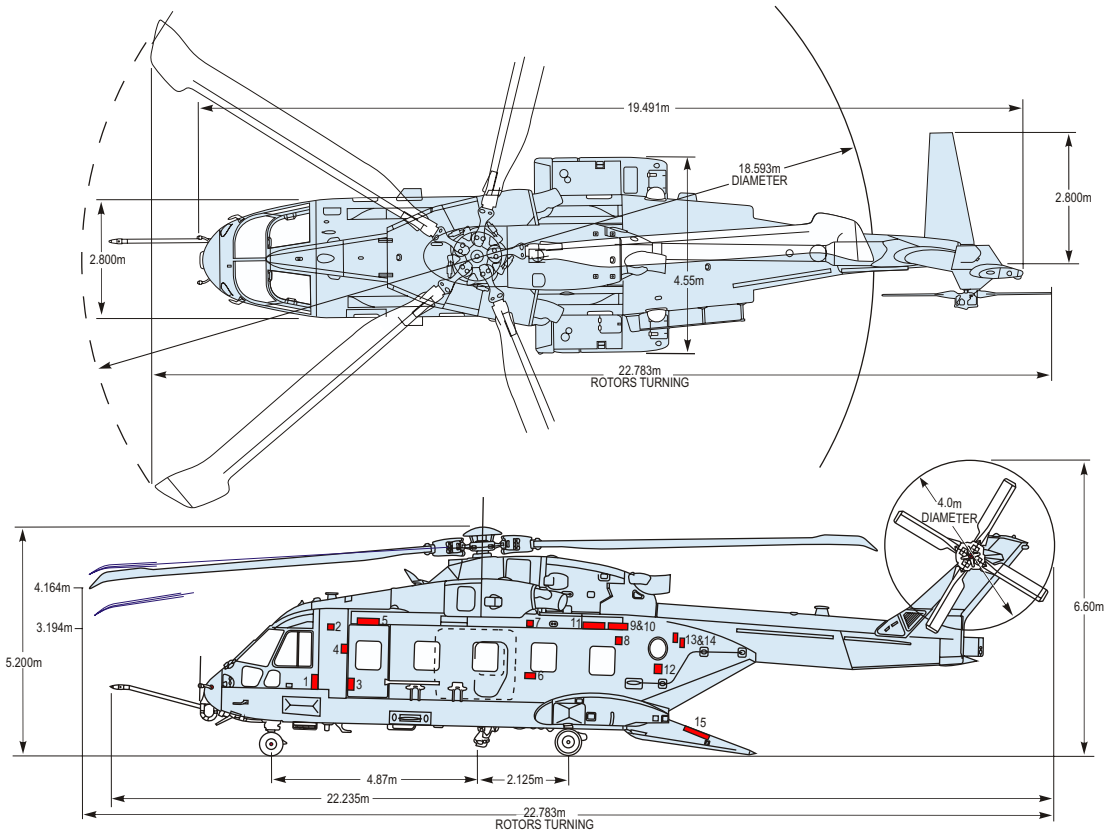

ITEMS REQUIRING ACCESS DURING LOADING AND/OR IN FLIGHT

ITEM No.	DESCRIPTION	ACCESS		LOCATION		
		LOADING	IN FLIGHT	PORT	STBD	OVERHEAD
1	FIRE EXTINGUISHER	/	/	/	/	/
2	VERY PISTOL / FLARES	/	/	Left & Right of centre aisle		
3	ELFAK & FIRE GLOVES	/	/	/	/	/
4	CCU	/	/	/	/	/
5	FAKPA	/	/	/	/	/
6	APU EMERGENCY SHUTDOWN CONTROL	/	/	/	/	/
7	CCS	/	/	/	/	/
8	RAMP RELEASE HANDLE	/	/	/	/	/
9	RAMP CONTROL	/	/	/	/	/
10	CCS	/	/	/	/	/
11	FAKPA	/	/	/	/	/
12	CCS	/	/	/	/	/
13	FIRE EXTINGUISHER	/	/	/	/	/
14	FIRE AXE	/	/	/	/	/
15	RESTRAINT EQUIPMENT	/	/	Ramp under floor stowage bins		

**CAUTIONARY NOTE**  
ALL DATA ON THIS SHEET IS ADVISORY ONLY  
ANY AIRPORTABILITY APPLICATIONS SHOULD  
BE UNDERTAKEN IN CONSULTATION WITH  
DEF STAN 00-3 AND JADTEU

ALL DIMENSIONS ON THIS SHEET ARE APPROXIMATE AND IN METRIC

ISSUED BY: JOINT AIR DELIVERY TEST AND EVALUATION UNIT (JADTEU)  
BRIZE NORTON  
OXFORD  
OX18 3LX

CHINOOK ALL MKS DATA SHEET

ANNEX B1

FLOOR LOADING

MAXIMUM WHEEL LOADS IN TREADWAY:

ENSURE THAT NO INDIVIDUAL WHEEL LOAD EXCEEDS 1360 kg. (3000 lb.)  
 ENSURE THAT TYRE CONTACT PRESSURES DO NOT EXCEED 60 kg./sq.in OR 135 lb./sq.in. (PNEUMATIC TYRES) AND 40 kg./sq.in. OR 90 lb./sq.in. (SOLID RUBBER TYRES)

TREADWAYS:

EACH CONCENTRATED LOAD NOT TO EXCEED ... 1360 kg. (and 40 kg./sq.in.)

REMAINDER OF CABIN FLOOR:

EACH CONCENTRATED LOAD NOT TO EXCEED ... 450 kg. (and 40 kg./sq.in.)

UD LOADING OF MAIN CABIN FLOOR:

FWD OF FS 200. NOT TO EXCEED ... 1000 kg./sq lin ft.  
 AFT OF FS 200. NOT TO EXCEED ... 1500 kg./sq lin ft.

MAIN CABIN

The main cabin floor area is approximately 30 ft. 6 in. long by 7 ft. 6 in. wide. Generally, the cabin height is 6 ft. 6 in. Critical frame dimensions are shown opposite.

Construction of the main cabin floor provides a treadway (between BL 20 and 44 left and right) which extends aft from FS 160 to FS 486. The floor between FS 200 and 400 and between BL 44 left and right, is isolated by insertion of rubber blocks between floor panels and aircraft sub-structure.

The tie-down point floor fittings are inset integral rings. These fittings are mainly of 2250 kg. (5000 lb.) ultimate strength, but 8 of 4535 kg. (10,000 lb.) tie-down points are located (4 each - port and stbd) in tie-down lines A and E.

NOTE:

The MFOS crewman seat is a standard fit. A DAS tower may be fitted on the cabin floor. When fitted the tie-down points A3, A4, B3 and B4 cannot be used. If the starboard mini gun is fitted the useable tie-down points start at row 5. If the extended range tank is fitted useable tie-down points start at row 9.

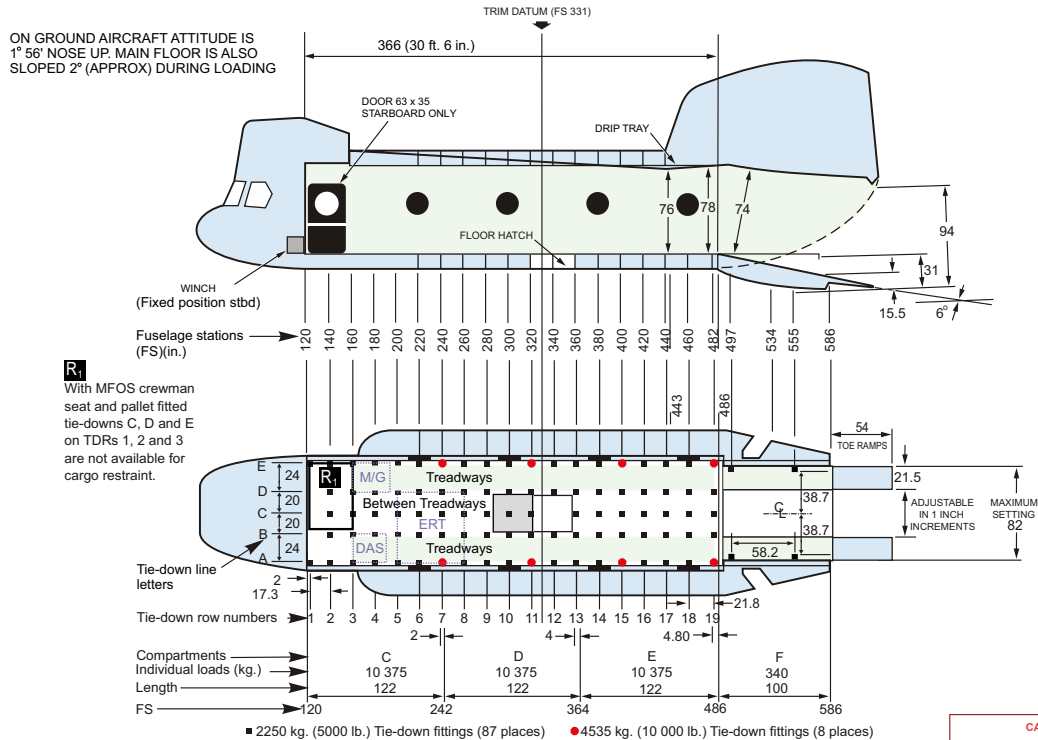
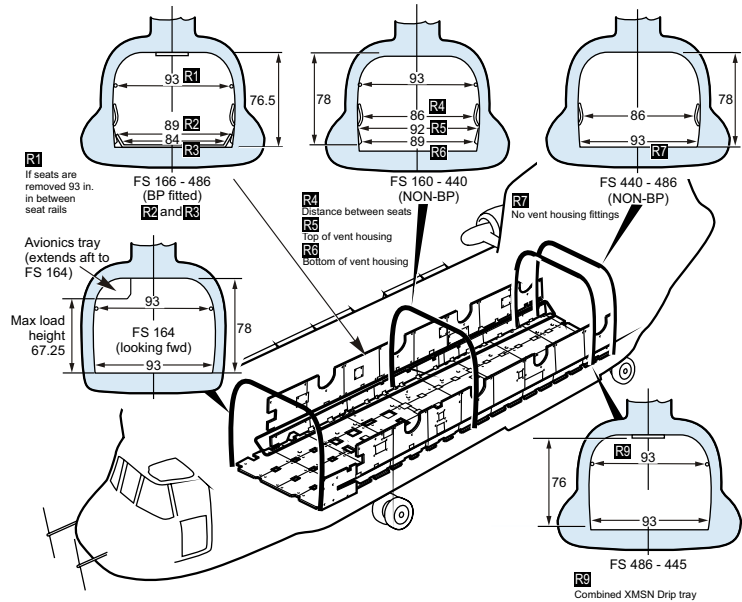

**CAUTIONARY NOTE**  
 ALL DATA ON THIS SHEET IS ADVISORY ONLY. ANY AIRPORTABILITY APPLICATIONS SHOULD BE UNDERTAKEN IN CONSULTATION WITH DEF STAN 00-5 AND JADTEU

ALL DIMENSIONS ON THIS SHEET ARE APPROXIMATE AND IN INCHES

ISSUED BY: JOINT AIR DELIVERY TEST & EVALUATION UNIT (JADTEU)  
 BRIZE NORTON  
 OXFORD  
 OX18 3LX

CHINOOK ALL MKS DATA SHEET

ANNEX B1

READY ACCESS

Ready access requirements in the main cabin are as follows:

- A minimum of 14 inches between the load and the fuselage wall (at waist height) along one side of the aircraft, OR
- A minimum of 30 inch (square) between the top of the load and the fuselage roof.

On the ramp a minimum of 14 inches between the load and the aircraft structure is required on both sides.

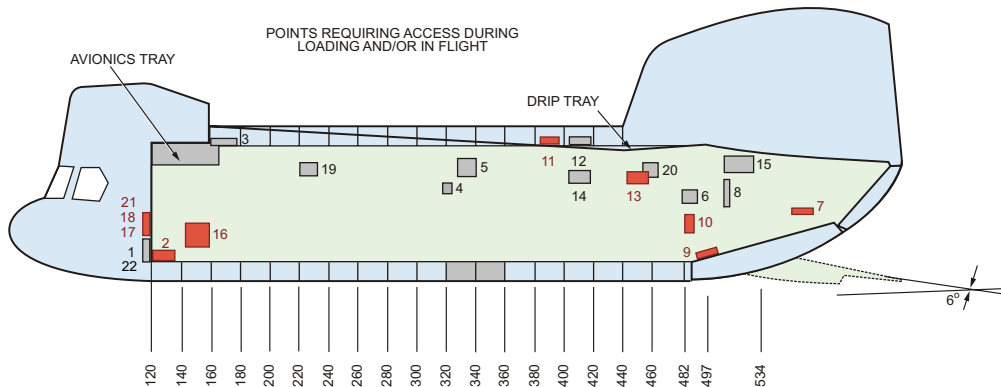
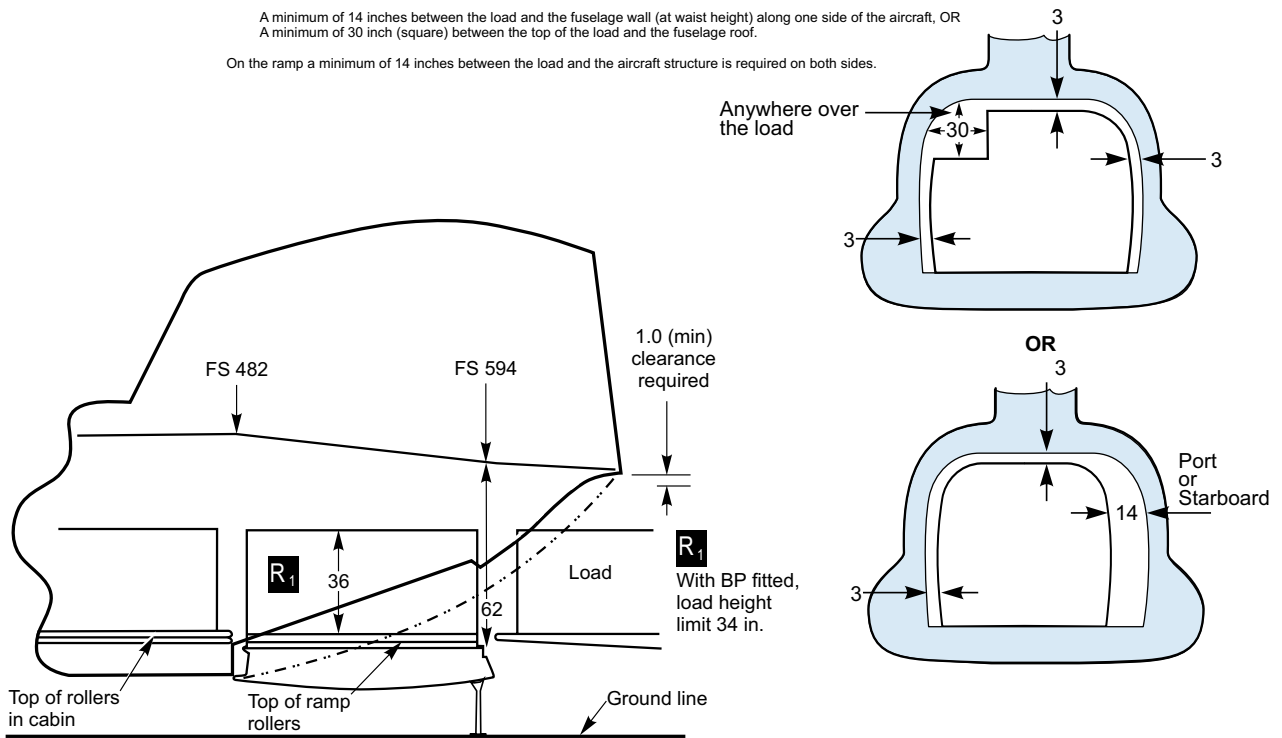

ITEM No.	DESCRIPTION	ACCESS REQUIRED		LOCATION	
		LOADING	IN FLIGHT	PORT	STBD
1	FIRE EXTINGUISHER	NO	YES		●
2	ELFAK	NO	YES	●	
3	CCS CONTROL	NO	YES		●
4	CCS CONTROL	YES	YES		●
5	WINCH CONTROL	YES	NO		●
6	RAMP CONTROLS	YES	YES		●
7	APU FUEL SHUT-OFF VALVE	YES	YES	●	
8	RAMP HAND PUMP LEVER				●
9	RAMP DOOR EMERGENCY CONTROL			●	
10	FIRE EXTINGUISHER	YES	YES	●	
11	No 1 DECU	NO	YES	●	
12	No 2 DECU	NO	YES		●
13	No 1 AUX PDP	NO	YES	●	
14	No 2 AUX PDP	NO	YES		●
15	MAINT PANEL	NO	YES		●
16	VEREY PISTOL/FLARES	NO	YES	●	
17	FIRE AXE	NO	YES	●	
18	FIRE GLOVES	NO	YES	●	
19	DUFAK	NO	YES		●
20	DUFAK	NO	YES		●
21	AVIONICS COMPARTMENT	NO	YES	●	
22	HEATER COMPARTMENT	NO	YES		●

READY ACCESS

There is to be an all round clearance between the load and the aircraft structure above floor level, of 1 inch during loading and 3 inches during flight. Ready access is also required to the crew compartment/crew stations, one of the two emergency exits at FS 160 and to all the items/locations shown on the left.

**CAUTIONARY NOTE**  
ALL DATA ON THIS SHEET IS ADVISORY ONLY. ANY AIRPORTABILITY APPLICATIONS SHOULD BE UNDERTAKEN IN CONSULTATION WITH DEF STAN 00-3 AND JADTEU

ALL DIMENSIONS ON THIS SHEET ARE APPROXIMATE AND IN INCHES

ISSUED BY: JOINT AIR DELIVERY TEST & EVALUATION UNIT (JADTEU)  
BRIZE NORTON  
OXFORD  
OX18 3LX

CHINOOK ALL MARKS CABIN BALLISTIC PROTECTION

ANNEX B2

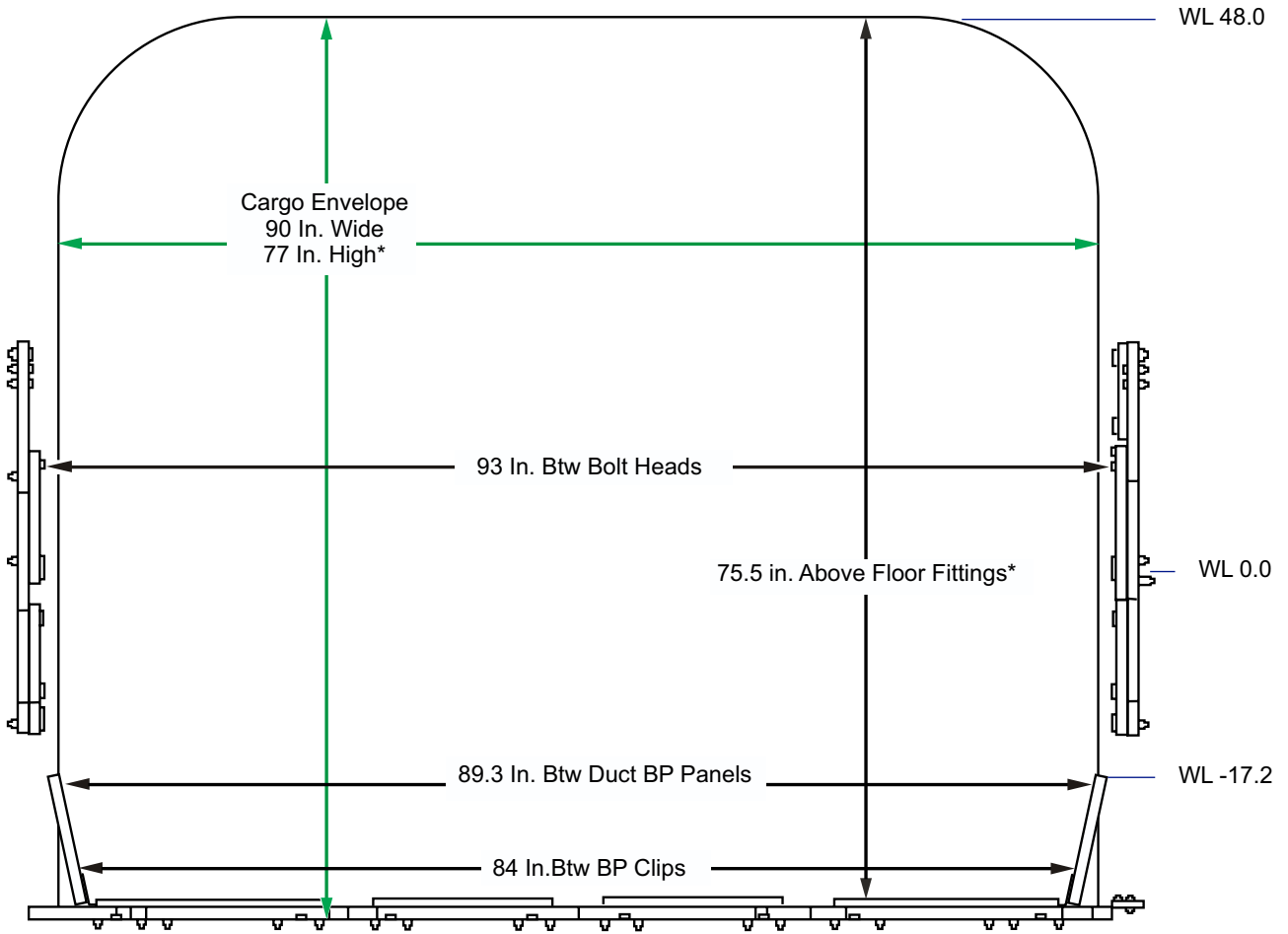

\*Between FS 166-443

CHINOOK ALL MARKS CABIN BALLISTIC PROTECTION

ANNEX B3

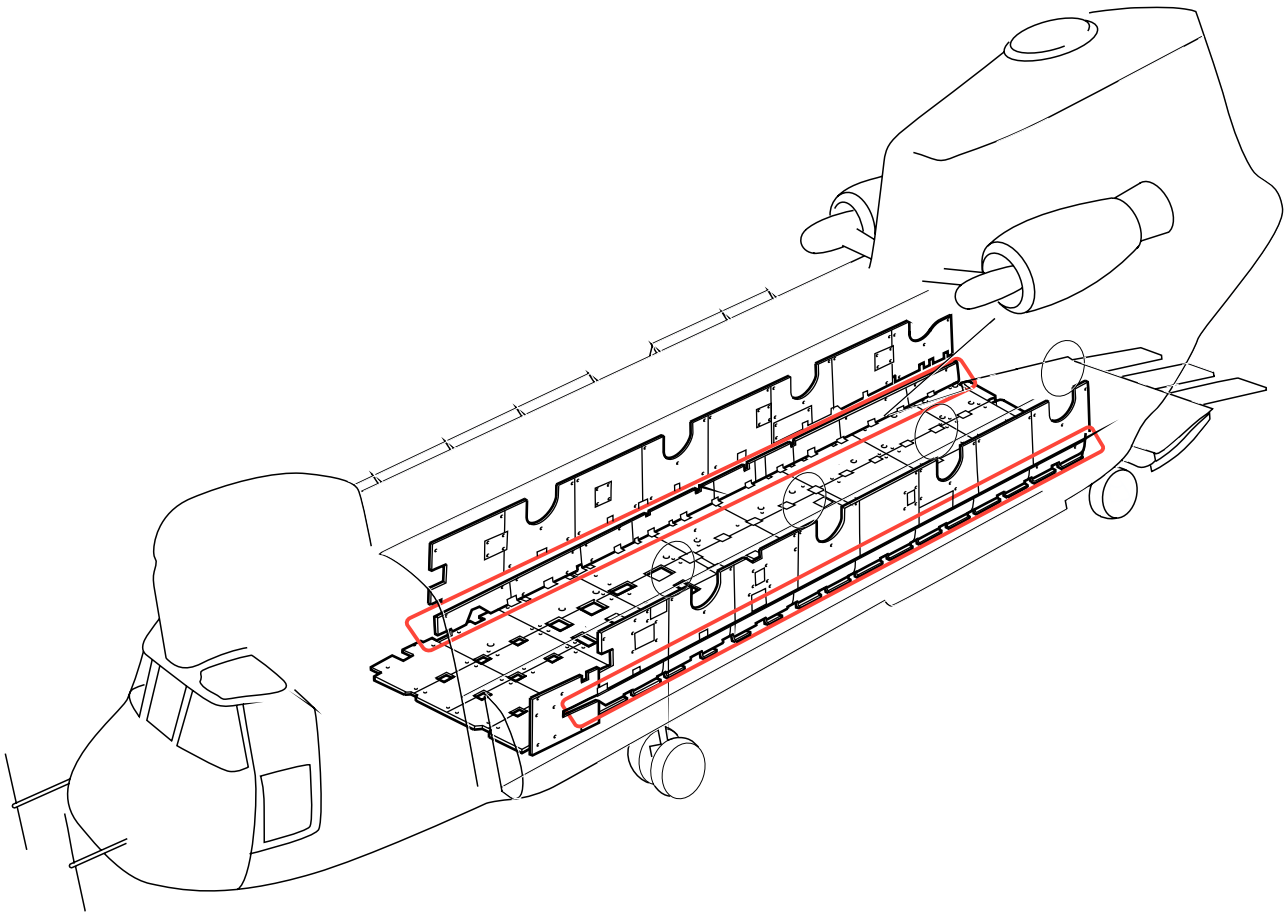

Areas that encroach on 90 in.  
Cargo Envelope  
-Buffer Board Panels LH and RH

C-17A GLOBEMASTER DATA SHEET

ANNEX C

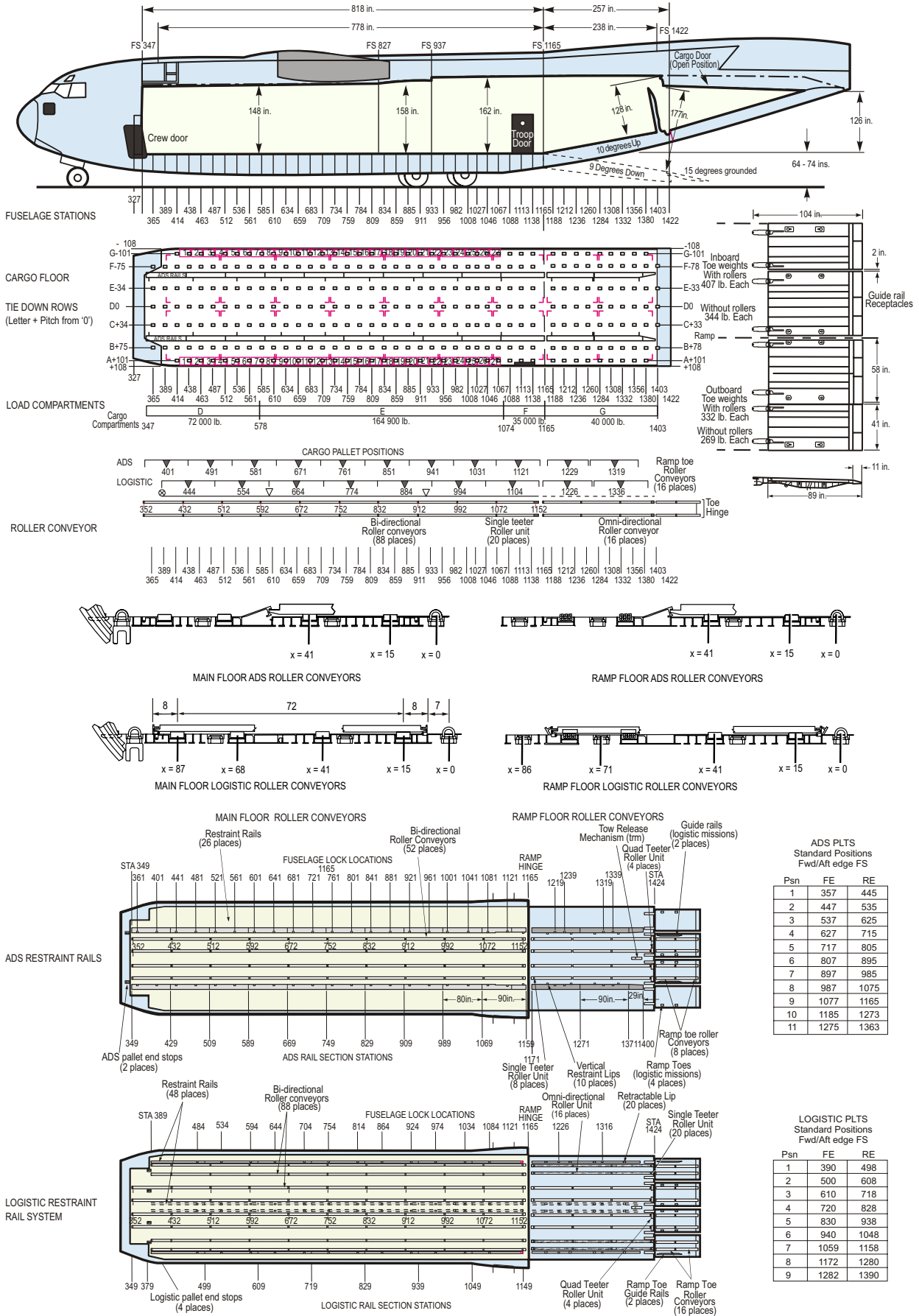

ADS PLTS Standard Positions Fwd/Aft edge FS

Psn	FE	RE
1	357	445
2	447	535
3	537	625
4	627	715
5	717	805
6	807	895
7	897	985
8	987	1075
9	1077	1165
10	1185	1273
11	1275	1363

LOGISTIC PLTS Standard Positions Fwd/Aft edge FS

Psn	FE	RE
1	390	498
2	500	608
3	610	718
4	720	828
5	830	938
6	940	1048
7	1059	1158
8	1172	1280
9	1282	1390

C-17A GLOBEMASTER DATA SHEET

ANNEX C

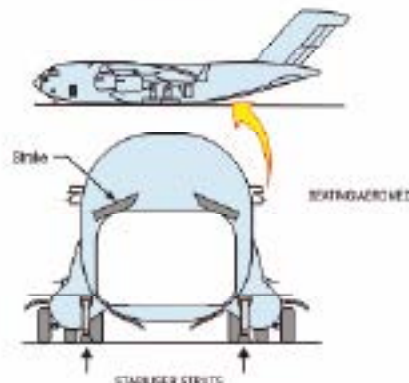
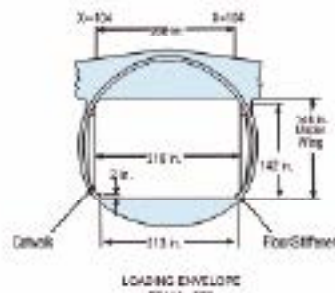
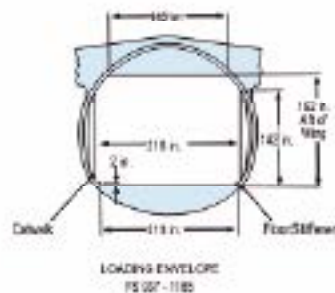
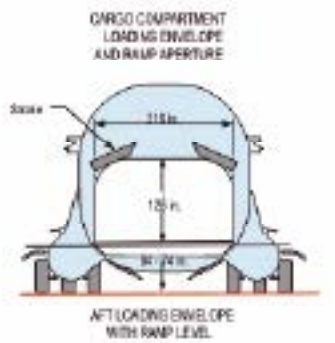

PS 1180-Port & Starboard  
Can be deployed for loading  
or airtank parking operations  
(Refer to TO-1C-17A-1)

**CAUTIONARY NOTE**  
ALL DATA ON THIS SHEET IS ADVISORY ONLY  
ANY AIRPORTABILITY APPLICATIONS SHOULD  
BE UNDERTAKEN IN CONSULTATION WITH  
EMF STAFF 063 AND JADTEU

ISSUED BY: JOINT AIR DELIVERY TEST & EVALUATION UNIT (JADTEU)  
RAF BRIDEHOPE  
CARTBERTON  
OX18 2LK

<b>MAXIMUM LOAD WEIGHT</b> .....	164 000 lb.
<b>MAXIMUM LOAD - Left or Right of 0'</b> .....	93 000 lb.

**SEATS**

Sideview (Fixed) .....	94
Centreline (8 x 6-seat modules) .....	48
<b>Total Seating capacity</b> .....	102

**AIRCRAFT** .....

**PALLETS (MEL Type)**

AOS (108 width single row) .....	11
LOGISTICS (80 width double row) .....	10
<b>Pallet Height Limits</b>	
AOS/LOGS pallet combination at FS 1160..	60 in.

**FLOOR ROLLER LIMITS** .....

B-Directional roller .....	2000 lb / 2000 lb
Omn-Directional roller .....	1949 lb / 1000 lb
Single Taster roller .....	3000 lb / 3000 lb

**FLOOR LOADING**

Max Pneumatic Tyre Pressure .....	100 PSI+
+ If above 100 PSI refer to TO-1C-17A-4	
Max Single Axle Weights (C/L Loaded) .....	22 000-27 000 lb.
Compartments D+E+G .....	27 000-36 000 lb.
Max Cargo Weights	
Compartments D+E+F+G .....	164 000 lb.
Compartments E .....	164 000 lb.

**CARGO FLOOR TIE-DOWNS**  
(All directional crating) .....

	25 000 lb.
--	------------

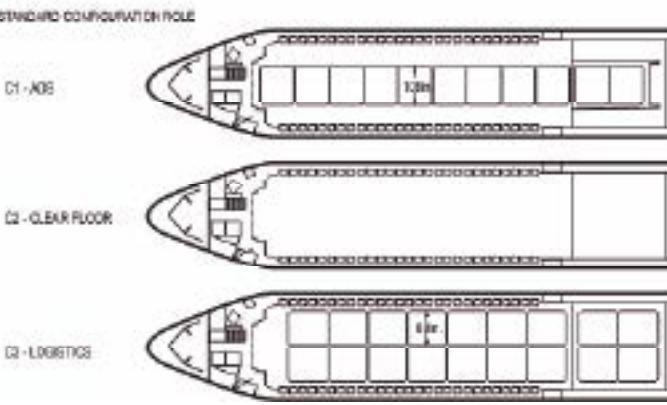
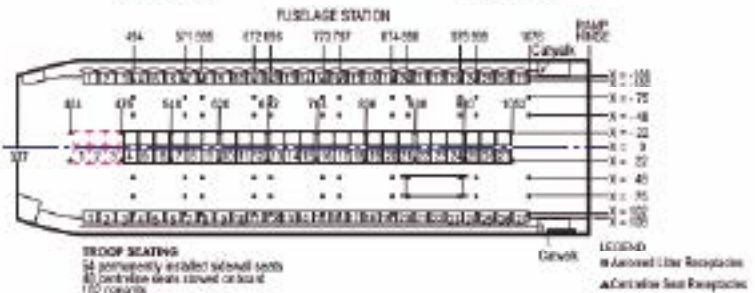
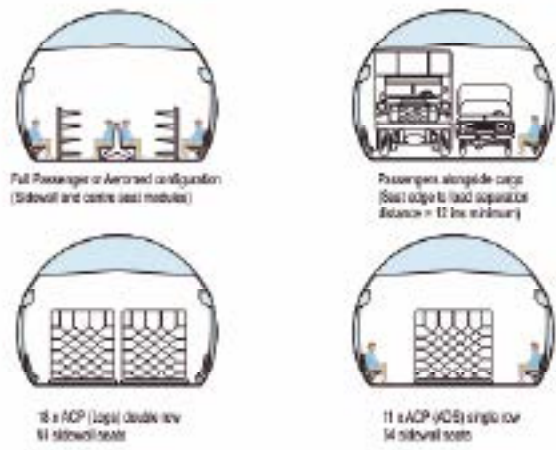

A400M DATA SHEET

ANNEX D

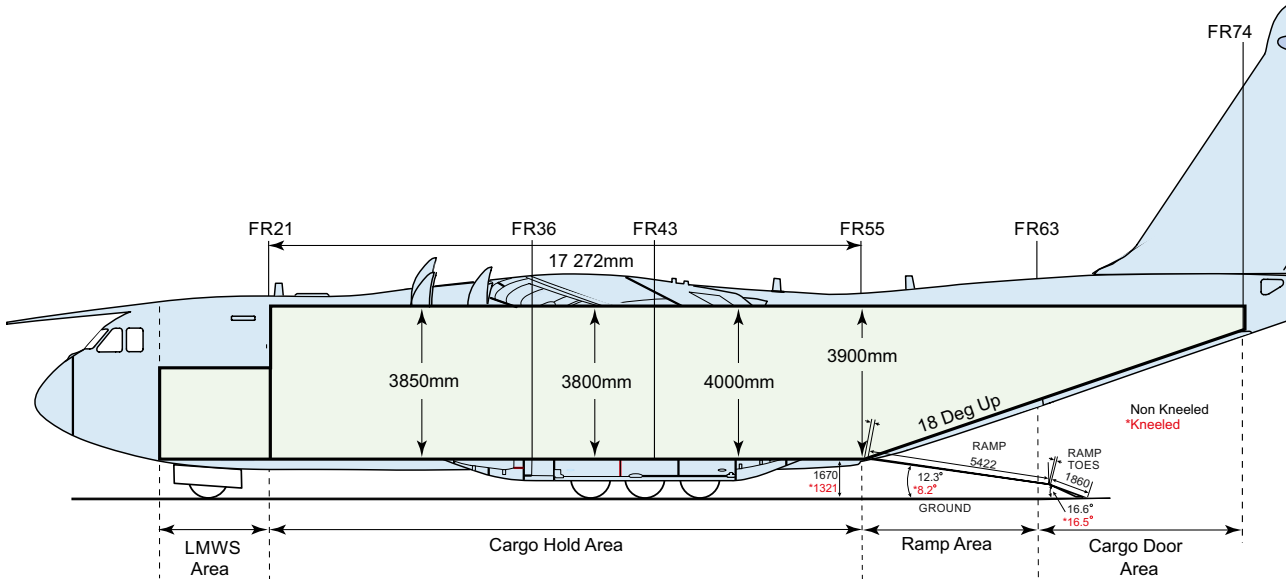

Cargo Floor Plan

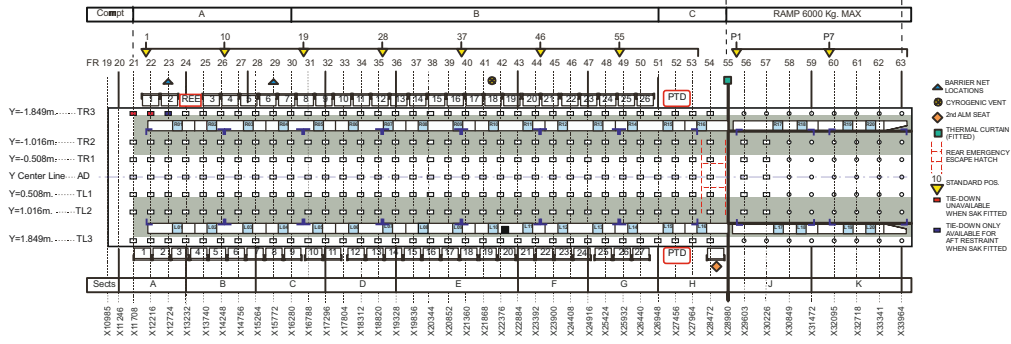

Toe Ramp Detail

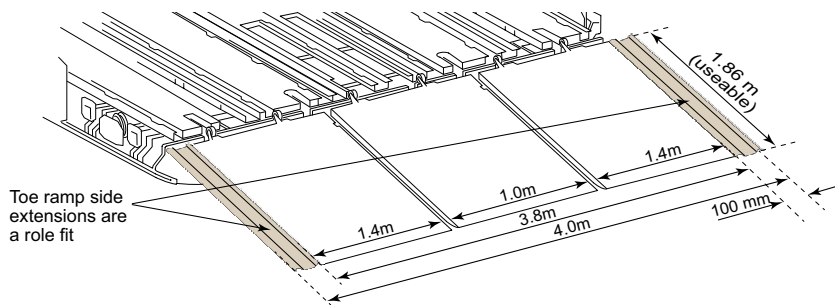

A400M Cabin Hold Floor Tie-Down Points

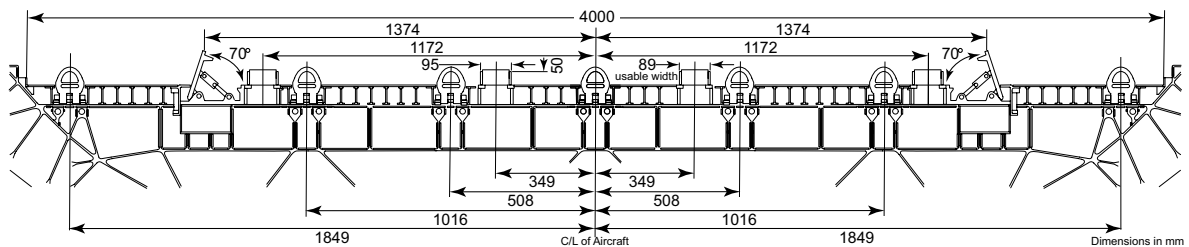

CABIN HOLD FLOOR TREADWAY AND NON TREADWAY

The cargo hold floor is divided in the Y axis (lateral) into treadways and non treadways, with different load limitations. The treadway area has the higher load limits, this is between Y = 0.582 m and Y = 1.775m left and right of the cabin centre line (AD).

**A400M DATA SHEET**

**ANNEX D**

**Wheeled Loads**

Factors to be considered to determine the limitations for wheeled loads are: axle weight; number of axles; suspension; pneumatic or solid tyres; track; axle spacing and track.

**Roller Restraint System for 463L (HCU-6/E)**

**Air Cargo Pallets**

The aircraft can be configured with a roller restraint system for 108 in. wide 463L air cargo pallets. The roller system has four roller conveyor rows in the longitudinal direction that enables the loading of the air cargo pallets. A maximum of 7 pallets can be accommodated in the cargo hold area and 2 on the ramp in a single row. The maximum weight of the pallet is limited by the running load it generates over each supporting roller track and the limitation of the 463L air cargo pallet. JADTEU must be consulted to provide advice on air cargo pallet limitations.

**Tracked Loads**

Factors to be considered to determine the limitations for tracked vehicles are: suspension (articulated or rigid suspension); vehicle weight; max vehicle running load; max weight per track; max track running load; contact area of each wheel; separation distance between wheels. JADTEU must be consulted to provide advice on vehicle limitations.

**Aircraft Kneeling**

The landing gear kneeling system enables:

- The reduction of the height of the cargo hold floor in order to reduce the crest angle between the cargo hold floor and the ramp floor.
- The control of the aircraft roll angle in order to adjust the cargo hold floor and the ramp floor to a truck bed, or a ground handling equipment.

**463L Pallet Positions - RAF Standard Positions**

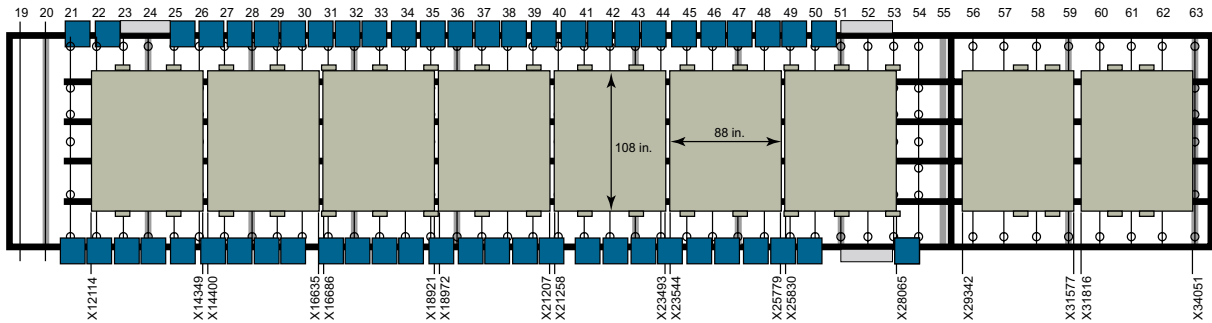

**Roller Conveyor Assemblies**

Main Floor Conveyor

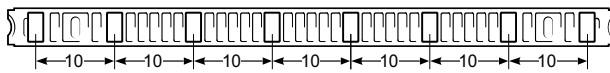

Fwd Ramp Conveyor

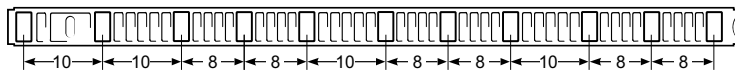

Aft Ramp Conveyor

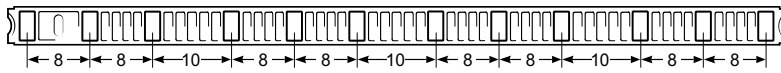

Dimensions in inches

**Cargo Door and Ramp Opening**

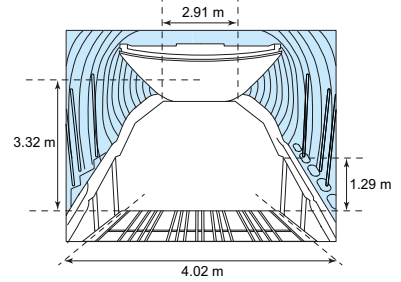

When the ramp is in horizontal position and the cargo door is open, the opening for loading of ULD, or for airdrop of load, is defined by the following dimensions:  
 The maximum height between the ramp floor and the cargo door is 3.32 m.  
 The width is 4.02 m from ramp floor to the height of 1.29 m.  
 The width at the maximum height between the ramp floor and the cargo door is 2.91 m.  
 From the height of 1.29 m to the maximum height of 3.32 m, the available width opening reduces gradually from 4.02 m to 2.91 m.

Max running load and max weight	Cargo hold area			Ramp area
	Comp A FR21 - FR30	Comp B FR30 - FR51	Comp C FR51 - FR55	Ramp FR55A - FR63
Inboard roller conveyor (Y = + 0.349 m)	1390 kg/m 353 kg per roller	1470 kg/m 373 kg per roller	1390 kg/m 353 kg per roller	990 kg/m 251 kg per roller
Outboard roller conveyor (Y = + 0.349 m)	1680 kg/m 427 kg per roller	1780 kg/m 452 kg per roller	1680 kg/m 427 kg per roller	990 kg/m 251 kg per roller

**Cargo Hold Envelope FS 21 - FS 36**

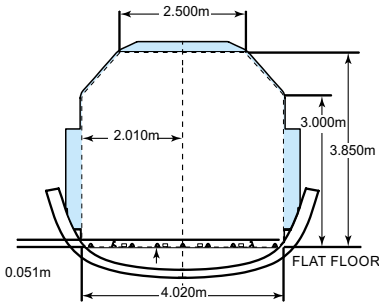

**Cargo Hold Envelope FS 36 - FS 43**

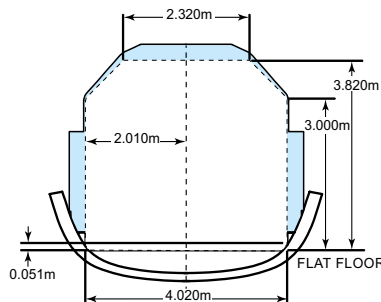

**Cargo Hold Envelope FS 43 - FS 55**

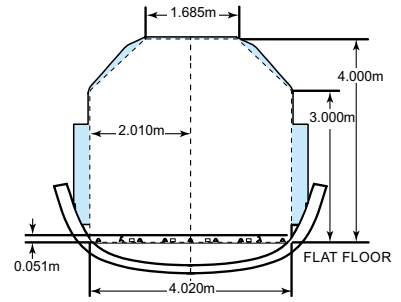

**CAUTIONARY NOTE**  
 ALL DATA ON THIS SHEET IS ADVISORY ONLY  
 ANY AIRPORTABILITY APPLICATIONS SHOULD  
 BE UNDERTAKEN IN CONSULTATION WITH  
 DEF STAN 003-3 AND JADTEU

ISSUED BY: JOINT AIR DELIVERY & TEST EVALUATION UNIT  
 (JADTEU)  
 RAF BRIZE NORTON  
 CARTERTON