



# Monolithic MOFs for Enhanced Cryoadsorbed Hydrogen Storage

HySupply Phase 2 Final Report



© Crown copyright 2025

This publication is licensed under the terms of the Open Government Licence v3.0 except where otherwise stated. To view this licence, visit [nationalarchives.gov.uk/doc/open-government-licence/version/3](https://nationalarchives.gov.uk/doc/open-government-licence/version/3) or write to the Information Policy Team, The National Archives, Kew, London TW9 4DU, or email: [psi@nationalarchives.gov.uk](mailto:psi@nationalarchives.gov.uk).

Where we have identified any third-party copyright information you will need to obtain permission from the copyright holders concerned.

## Executive Summary

The project, funded by DESNZ under the NZIP Low Carbon HySupply Programme (Stream 1) and officially titled “*Monolithic MOFs for Enhanced Cryo-adsorbed Hydrogen Storage*,” set out to advance and demonstrate the potential of monolithic Metal-Organic Framework (m-MOF) technology for hydrogen storage. It aimed to move from laboratory-scale investigations through to the design, construction, and testing of a full demonstrator system integrated into a hydrogen fuel cell bus. The work was structured across several phases, including material development and characterisation, test-rig, and prototype systems design and testing, demonstrator construction and validation, and techno-economic and environmental assessment.

The project successfully delivered three major hardware milestones: the 2 L test rig, the 20 L prototype, and the ~200 L demonstrator system. The demonstrator was installed on a fuel cell electric bus, enabling a successful driven test, which represented a key target outcome for the project and which validated the feasibility of operating MOF-based storage in real-world transport conditions. The learning from building the engineering system identified areas for refinement in future work. Several lessons were learned during the project that will inform future development. Complementary studies provided further important insights; the techno-economic and environmental assessments indicated that MOF technology holds significant promise for intermediate hydrogen storage applications, where performance targets and cost thresholds may be achievable. This opens a valuable pathway for commercialisation beyond mobility applications.

Overall, the project has successfully demonstrated the potential of m-MOF-based hydrogen storage at scale, delivered valuable operational experience with a full demonstrator in a real-world setting, and established a foundation for further development in both transport and intermediate storage applications.

## Contents

Executive Summary .....	3
Abbreviations .....	7
1. Background.....	8
2. Project Overview.....	10
3. Design Considerations and Challenges .....	12
4. Demonstrator Study .....	34
5. Project Metrics .....	44
6. Secondary Project Benefits.....	46
7. Project Management.....	47
8. Commercialisation Plans.....	48
9. Conclusions and Next Steps .....	52
10. References .....	53

## List of Figures

Figure 1 - High Level Project Schedule .....	11
Figure 2 - Packed density of 2.8mm diameter spheronised pellets, mixed length.....	16
Figure 3 - Test Rig Schematic.....	18
Figure 4 - Test Rig: Photograph of the Constructed Test Rig.....	19
Figure 5 - Prototype Operations .....	20
Figure 6 - Fuel Cell Bus Mission Profile for Prototype Simulation .....	21
Figure 7 - MTC Prototype Tank.....	22
Figure 8 - Prototype Tank Assembly .....	23
Figure 9 - Demonstrator Tank with Integrated System .....	25
Figure 10 - Tank (Encircled) Installation on Bus.....	26
Figure 11 - Bus Onboard Installation.....	27
Figure 12 - Ground System Setup Build.....	28
Figure 13 - Experimentally validated equilibrium model of hydrogen uptake .....	29
Figure 14 – Prototype (left) and Demonstrator (right) Tank Epoxy .....	33
Figure 15 - Safety requirements derivation .....	34
Figure 16 - Tank Reactivation Temperatures .....	37
Figure 17 - Initial Cooling Cycle .....	38
Figure 18 - Final Cooling Cycle .....	38
Figure 19 - Coil Cooling from Ambient .....	39
Figure 20 - Improvements to Cooling Temp. from Initial to Final (Orange) Cooling Cycle .....	39
Figure 21 - Tank Ice Formation Pre-Vacuum Jacket Improvements .....	40
Figure 22 - Tank Ice Build .....	40
Figure 23 - Tank Pressure vs FC Consumption .....	42
Figure 24 - Contributions to GWP for the three phases considered in the LCA study .....	45

## List of Tables

Table 1 - Demonstration Testing Schedule .....	35
Table 2 - LN2 Consumption .....	40

## Abbreviations

<b>Abbreviation</b>	<b>Description</b>
AHFC	Aggregated Hydrogen Freight Consortium
ARC	Abbott Risk Consulting
BET	Brunauer-Emmett-Teller
CAPEX	Capital Expenditure
CFD	Computational fluid dynamics
COTS	COTS Commercial Off-The-Shelf
DAQ	Data Acquisition
DSEAR	Dangerous Substances and Explosive Atmospheres Regulations
GHG	Greenhouse Gas
GWP	Global Warming Potential
HAZOP	Hazard and Operability Study
HRS	Hydrogen Refuelling Stations
LN <sub>2</sub>	Liquid nitrogen
LCOH	Levelised Cost of Hydrogen stored
LCOS	Levelised Cost of Storage
LDES	Long-Duration Energy Storage
MOF	Metal organic framework
MTC	Manufacturing Technology Centre
PEM	Polymer Electrolyte Membrane
RTD	Resistance Temperature Detector
RGA	Residual Gas Analyser
SOFC	Solid Oxide Fuel Cell
TRL	Technology Readiness Level

## 1. Background

### 1.1. Company Information

Immaterial Ltd is a cleantech company based in Cambridge, United Kingdom, founded in 2015 as a spin-out from the University of Cambridge. The company currently employs around 35 science and engineering professionals plus administrative support staff. The company specialises in developing and supplying unique monolithic metal-organic frameworks (*m*-MOFs) with superior volumetric capacity, together with process system designs that maximise the efficacy of these materials in use. These advanced materials are designed for applications such as carbon capture from point sources and volume-efficient, low pressure hydrogen storage.

The founding team includes Prof. David Fairen-Jimenez, who serves as Chief Scientific Officer, and leads the development of the company's fundamental technology. He is Professor of Molecular Engineering in the Department of Chemical Engineering at the University of Cambridge, where he leads the Adsorption & Advanced Material Laboratory. The company is headquartered at 25 Cambridge Science Park, Milton Road, Cambridge, England CB4 0FW and is constructing a new *m*-MOF manufacturing facility at Accelerator Park, Sawston, England, CB22 3FG.

### 1.2. Project Background

Cryo-adsorbed technology has been considered one of the most promising concepts for tackling the challenge of low cost, high volume, ergonomic storage of hydrogen for many years. This type of storage uses relatively benign conditions to store hydrogen in an adsorbed phase using ultra-porous materials that soak up gas like a sponge soaks up water.

The most significant challenge for cryo-adsorbed hydrogen is volumetric storage capacity. *m*-MOFs have shown excellent gravimetric uptake when formed as ultrafine powders. However, conventional MOF powders pack poorly and, if compacted, their porosity collapses reducing both volumetric and gravimetric capacities.

Immaterial's unique, patented technology produces *m*-MOFs as dense crystal "monoliths". This drastically increases volumetric capacity while maintaining gravimetric uptake. Additionally, the size of monolith particles may be controlled to maximise packing efficiency in use, the technology platform can be applied to any *m*-MOF chemistry opening a range of potential materials, and the monoliths can be optimised for heat capacity and thermal conductivity, further enhancing their performance.

Phase 1 of the Low Carbon HySupply 2 – Stream 1 programme carried out a feasibility study, which included a techno-economic analysis comparing state-of-the-art high-pressure (350 bar)

hydrogen storage tanks with Immaterial's m-MOF cryo-adsorbed hydrogen storage solution. This analysis confirmed that Immaterial's approach can deliver:

- greater volumetric storage
- significantly lower operating pressure requirements
- improved total cost of ownership in selected applications
- enhanced energy efficiency across the hydrogen supply chain

As part of this feasibility study, a computational fluid dynamics (CFD) model was developed to understand m-MOF bed behaviour during loading, dormancy, and unloading. For the first time, experimental work collected heat-and-mass transfer data in monoliths to validate and inform the CFD model. In parallel, Immaterial advanced second-generation materials with substantially higher capacities, optimised for thermal conductivity, stability, and cost-effective synthesis.

Phase 1 concluded with optimised materials and the most comprehensive cryo-adsorption model to date, that together underpinned a preliminary design for a demonstrator that was proposed as the next phase of the project.

This project (Phase 2 of the Low Carbon HySupply 2 - Stream 1 programme) has developed a system demonstrator based on Immaterial's record breaking materials [1]. The demonstrator is designed and installed on a prototype hydrogen fuel cell electric bus provided by a third-party partner (Ricardo). In addition to Ricardo, the project has been developed in partnership with the Manufacturing Technology Centre (MTC) with support from Element Digital Engineering (Element) - formerly "Filton Systems Engineering", Glacier Energy, (Glacier) and Abbott Risk Consulting Ltd (ARC).

This phase 2 project follows an iterative "build-test-refine" pathway, first constructing an experimental test rig that demonstrated basic loading/storage/unloading cycles and refined the Phase 1 computational system model of cryo-adsorbed hydrogen storage that is based on first-principles simulations of adsorption and desorption behaviour, thermodynamics, and system energy flows. This refinement increased model fidelity, ensuring accurate performance predictions to guide subsequent prototype and demonstrator developments.

A prototype implemented learnings from the test rig and addressed challenges for system control, thermal management, and safety. Finally, a demonstrator was built for quantifiable system performance, well-understood behaviour in different use scenarios, and a pathway towards commercialisation.

## 2. Project Overview

### 2.1. Aims and Objectives

The overarching technical aim of this project is to demonstrate the feasibility of a cryo-adsorbed hydrogen storage system, culminating in the integration of a demonstrator into a commercial hydrogen fuel-cell bus.

Current *state-of-the-art* storage technologies rely on high-pressure (350 bar) compressed gas tanks, that typically achieve storage capacities of around 22 g/L. While proven, these systems impose high energy penalties for compression, involve costly infrastructure, and raise safety and regulatory challenges due to high storage pressures.

Immaterial's approach, based on advanced metal–organic framework (MOF) materials and cryo-adsorption, seeks to deliver a step change in performance. Compared to compressed tanks, the project targets increased volumetric hydrogen densities at substantially lower operating pressures, offering a safer, more energy-efficient, and potentially lower-cost alternative. Beyond storage capacity, the technology can offer reduced boil-off losses and improved overall efficiency across the hydrogen supply chain.

At the outset, the technology sits at TRL 4, with technology validated in the lab. By the end of the project, the objective is to advance to TRL 6, demonstrating a full-scale storage system operating in a relevant environment.

### 2.2. Schedule, Deliverables and Financial Information

#### 2.2.1. Deliverables and Schedule

The project was structured into six main work packages (WP), with three of these focused on the design, development, and construction of the m-MOF-based hydrogen storage tanks at increasing scales: the 2 L Test rig, the 20 L Prototype tank, and the ~200 L Demonstrator tank installed on the hydrogen bus. Together, these form the core technical work packages of the project.

The remaining parts of the project were designed to support and inform these major deliverables: Work Package 1 (WP1) and Work Package 2 (WP2) addressed the upstream requirements necessary for successful demonstrator development, focusing respectively on the development and delivery of scaled-up MOF materials, and a detailed manufacturing cost estimate (WP1), and on comprehensive material characterisation studies (WP2). These activities ensured that the project was using robust data for material properties, scalability, and economic viability.



a two-week testing period and subsequent reporting. The successful completion of this stage provided essential proof-of-concept data and informed the design of the subsequent prototype tank.

Development of the 20L prototype tank commenced in September 2023 and was extended to completion of testing in February 2025.

Activities on the ~200L demonstrator tank began with design and development in June 2024. Fabrication and integration followed, leading to a comprehensive testing campaign that took place during July and August 2025. The demonstrator phase represented the culmination of the project, showcasing the demonstrator system in the driven operation of a double-decker hydrogen bus on 31<sup>st</sup> of July 2025.

In parallel, MOF material development, scale-up, and production were carried out at Immaterial's laboratories. This work commenced near the start of the project and continued through to November 2024, providing a sufficient supply of material for the successive testing phases.

### **2.2.3 Financial Information**

The total funding received from DESNZ for this project was £3,459,378.52.

## **3. Design Considerations and Challenges**

### **3.1 WP1 Material Fabrication Scale-up**

#### **3.1.1. Scaled-up Material Delivery for test rig, prototype and demonstrator**

Converting conventional synthesis pathways to green and cost-effective processes is crucial to realising scaled-up production. Implementing significant changes to the standard procedures necessitated various optimisations, including precursor concentration, reaction time, modulator concentration, and reaction temperature. These optimisations were necessary in producing the best-performing material with large porosity, high density, and a favourable reaction yield.

Two high-potential material candidates were identified during phase 1: MOF-15 and MOF-18. To improve scalability, affordability and environmental friendliness, the standard synthesis route for MOF-15 was adapted, using chemical alternatives and modifying the reaction parameters. Similar improvements were also produced for MOF-18 synthesis.

These modifications have resulted in the successful production of optimised materials for rig testing (2 kg each) that exemplify desirable properties at a reaction batch scale of 30 L. MOF-15 is optimised for storage at 25-50 bar, MOF-18 for storage at 100 bar.

Notwithstanding the successful synthesis of both materials for testing, it was decided to proceed with MOF-15 over MOF-18 for further production and testing. This decision was influenced most significantly by the emergence of understanding during detailed design and simulation of the

total system, that the total energy required to cool the system and compress the hydrogen reached a plateau at around 20-40 bar. Given this, it was decided to focus the testing on MOF-15, which was optimised for operation at 25-50 bar.

The production process for the prototype material (10 kg) was developed and further improved for the demo material (100 kg). Changing some batch processes into continuous processes helped massively to reduce manual work and time. Also, learnings from the production of the rig test material and the prototype were applied in the demo material production.

85 batches were synthesised in a 30 L reactor, producing 170 kg of demonstration material. Final products met the target densities (0.88–0.95 g/cm<sup>3</sup>) and BET surface areas (1280–1400 m<sup>2</sup>/g) consistent with Immaterial's patented technology.

The surface area of the materials was monitored throughout production using BET analysis of N<sub>2</sub> adsorption at -196°C (77K) to ensure consistent, high-quality output. Samples from activated batches were routinely tested, starting with the first batch in November 2024. To verify stability, a sample from that batch was reopened and reanalysed, showing identical isotherms to a sample activated on January 14<sup>th</sup>, 2025, confirming that packaging effectively preserved the material's capacity.

### **3.1.2 MOF Manufacturing Cost Estimate**

A robust estimate of the manufacturing costs for MOF15 was developed, to assess both commercial feasibility and scale-up potential. The work was based on figures estimated for a pilot plant designed by Immaterial in parallel with the HySupply project, to produce 5 tons of m-MOF per year, sufficient to supply material for approximately 45 MOF storage tanks annually. These cost estimates were informed by available process data, industry-standard costing methodologies, and reasonable engineering assumptions.

While the pilot plant was not yet fully operational at the time of the assessment, the costing exercise provides valuable insight into the economic drivers of MOF production, the scale-up challenges, and the potential areas for optimisation in future development phases.

The production costs at pilot scale depend on several categories, including raw materials, utilities, labour, capital expenditure, facility costs, maintenance, and other operational expenses. The estimates were calculated on the basis of a continuous 24/7 operation, with a conservative approach taken for any figures where there was a high degree of uncertainty.

#### **3.1.2.1 Key Cost Breakdown**

At small scale, the current estimated production cost for MOF15 is around £200 per kg.

### **3.1.2.2 Considerations and Exclusions**

Some simplifying assumptions are made, and the following were not include in the estimate but could have an impact once confirmed: shipping and logistics costs to customers, amortisation of intangible assets egal and accounting fees.

### **3.1.2.3 Industrial Scale Projection**

In parallel with the pilot-scale analysis, a preliminary cost estimate was developed for an industrial-scale facility producing 1000 tons/year of MOF15, to align with the estimated requirement for 10,000 MOF tanks. This scale-up exercise first calculated the yearly pilot plant output under continuous operation and then applied the six-tenths rule to estimate the capital cost for the larger facility. Operational costs were then estimated using standard cost factors from Plant Design and Economics for Chemical Engineers [2].

This industrial-scale projection provides a useful reference point for assessing economies of scale and identifying cost reduction opportunities. However, the figures are subject to significant uncertainty until more detailed engineering design and pilot plant operational data are available.

### **3.1.2.4 Conclusion**

When scaled up to an industrial facility producing 1000 tons/year, and after applying scaling factors and cost estimation methodologies, the projected cost drops to less than £20 per kg. This reduction demonstrates the substantial economies of scale achievable in MOF manufacturing.

As the process moves into operational phases, both the pilot- and industrial-scale estimates will be refined with actual performance and cost data.

## **3.2 WP2 Material Characterisation**

### **3.2.1 Material Robustness**

The mechanical durability of m-MOF materials has been enhanced to improve their mechanical strength while maintaining their adsorption capacity. Our assessment involved subjecting them to rigorous vibration testing using a vortex shaker. Both the monolithic materials exhibited impressive resilience and stability, with no signs of dusting or mass loss following the intensive vibration test conducted after the optimisations.

### **3.2.2 Packing Optimisation**

Increasing the packed density of MOF particles in hydrogen storage vessels offers a direct route to improved system level storage capacity, complementing material chemistry optimisation. A literature review and prior experimental observations identified key factors influencing packed

density: particle size distribution (PSD), average particle size and aspect ratio, particle shape, and the filling method.

The review showed that broader PSDs improve packing by allowing smaller particles to fill gaps between larger ones, and that particle shape and aspect ratio are also critical, with short spherocylinders often outperforming spheres and irregular forms. Filling techniques such as vibration during loading and dense phase loading devices can further enhance. These findings guided the subsequent experimental programme to determine the optimal particle form and loading method for large-scale hydrogen storage.

### 3.2.3. Key Conclusions

- **Particle Size Distribution (PSD)** – A broader PSD significantly improves packed density by enabling smaller particles to occupy voids between larger ones.
- **Particle Shape and Aspect Ratio** – Short, uniform shapes such as pellets can achieve efficient packing, potentially exceeding that of irregular cut material, though they lack the natural PSD advantage.
- **Pellet Benefits** – Pellets offer smoother surfaces, improved regularity, reduced manufacturing waste, and compatibility with continuous production processes, making them attractive for scale-up despite PSD limitations.
- **Filling Method Optimisation** – Techniques such as tank vibration during loading and dense phase loading devices can meaningfully increase packing efficiency by promoting uniform particle distribution. See the difference in packing density using vibration and funnels compared to direct pouring in Figure 2.

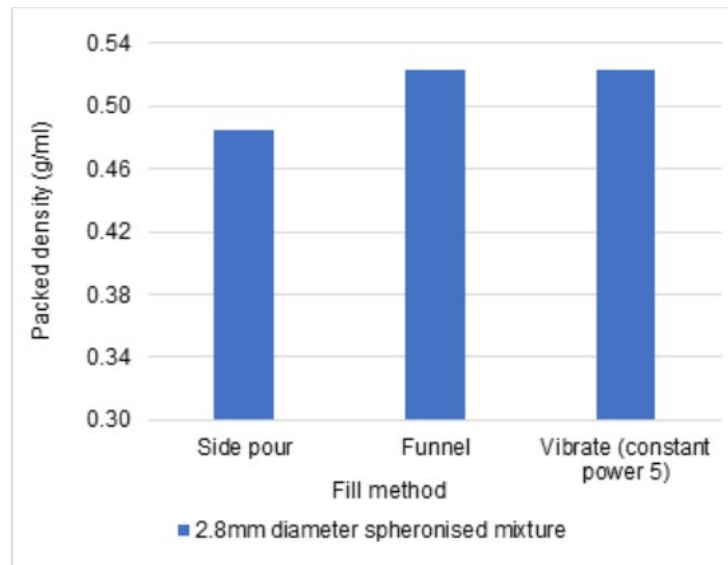

Figure 2 - Packed density of 2.8mm diameter spheronised pellets, mixed length

### 3.2.4. Tank Filling in Practice

The first prototype had a small inlet diameter which restricted the flow of MOF into the tank. The filling made use of vibration pads that increased the packing density. The MOF used was the original non-pelletised particles. The measured packing density was 345 kg MOF/m<sup>3</sup> tank.

The second prototype was the same as the first, but the MOF pellets were used for the first time. This larger form was difficult to charge into the tank, and a poor and sporadic flowrate was achieved with blockages occurring. Vibration was used to assist the charge of MOF through the inlet and to pack the MOF. High packing densities were observed, achieving 570 kg MOF/m<sup>3</sup> tank.

The demonstrator had a larger inlet and there was no restriction for pouring MOF into the tank. Limited vibration was used and the demonstrator achieved the highest packing density, 597 kg MOF/m<sup>3</sup> tank (0.597 g/ml).

As each tank fill was a one-off operation, it was not possible to fully investigate the variations of vibration and flowrates on the packing density for each vessel.

It can be concluded that the MOF pellets significantly increase the packing density of MOF.

### 3.3. System Design Including Detail on Engineering Design

The project and system design were developed through the three stages previously described.

### **3.3.1. WP3 Test Rig Build, Model Validation and Refinement**

The first design iteration of the cryo-adsorbed hydrogen storage system was the 2L test rig, designed to validate CFD simulations and first use of the MOF at scale. This included demonstrating the total equilibrium storage capacity of the MOF material, assessing heat transfer coefficients, and sensitivity testing of various modelling assumptions.

The design focussed on achieving cryogenic storage of hydrogen within the MOF prior to development of the final demonstrator system. A basic system was developed; the schematic can be seen in Figure 3 and the built system in Figure 4. The MOF was contained within a 2L vessel, with integrated probes providing temperature readings within the bed of MOF. Liquid hydrogen was flowed through the MOF bed providing simultaneous direct cooling and adsorption, with the whole setup contained within a vacuum cryostat to provide thermal insulation.

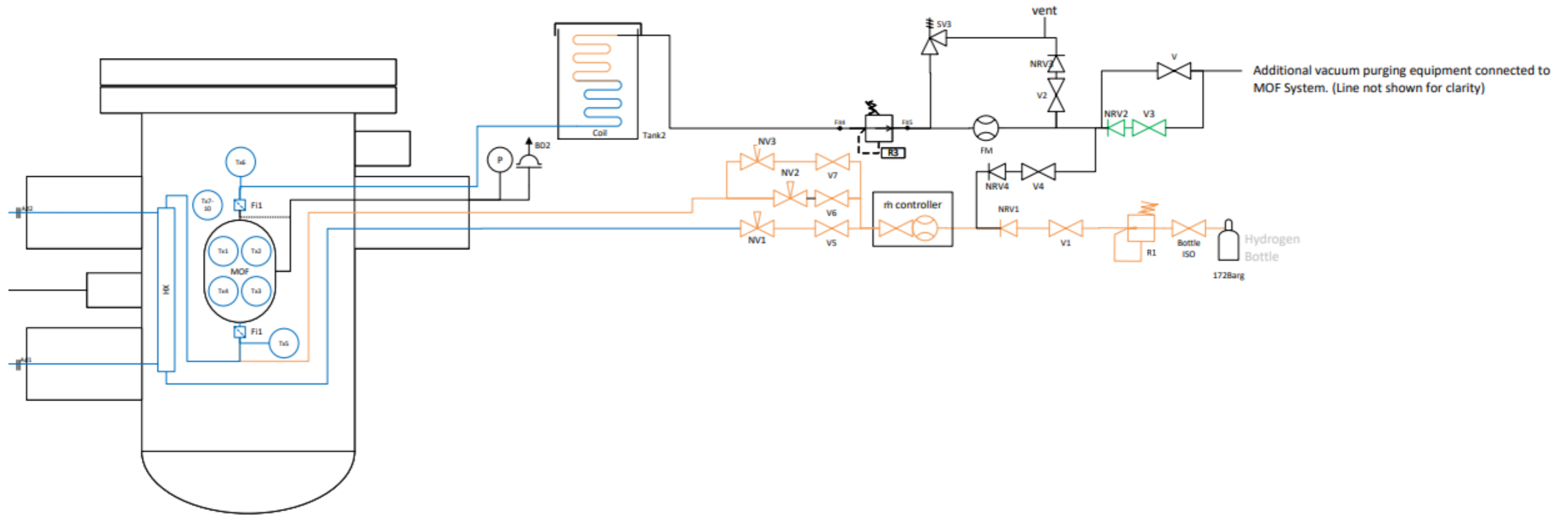

Figure 3 - Test Rig Schematic



**Figure 4 - Test Rig: Photograph of the Constructed Test Rig**

The photograph on the left of Figure 4 shows the constructed test rig, including its internal components and integrated connections housed within the storage cylinder.

The photograph on the right provides an external view of the cylinder, showing how it interfaces with the ground-based system. Visible in this image are the external fittings, pipework, and connection points that link the test rig cylinder to the supporting ground infrastructure used for filling, monitoring, and control during testing.

### **3.3.2. WP4 Prototype Design and Build**

The prototype stage of the development was a first attempt at designing, building and testing an operational MOF system. Objectives included developing feasible solutions for cooling, controlled (heating) discharge, verification of discharged hydrogen purity, and further validation of scaled up CFD models.

The prototype also included the design and build of a 20-litre tank for storage of MOF and hydrogen at cryogenic temperatures, with built-in insulation.

The prototype design moved away from the use of liquid hydrogen due to the quantities and costs required, and developed solutions using liquid nitrogen, that being more readily available and considerably cheaper than liquid hydrogen.

#### **3.3.2.1. Development of the Prototype System**

The prototype system was designed to operate a full storage cycle of hydrogen. Figure 5 illustrates the main operational steps for a cycle.

*Purging* with nitrogen removes other gases from the system ensuring that no flammable atmospheres are created with the introduction of hydrogen, and to removing potential contaminants.

*Reactivation* is an in-situ process in which the MOF is heated to remove any previously adsorbed gases and moisture. This process had two stages; first hot nitrogen flowed directly through the MOF bed to heat it to  $\sim 150^{\circ}\text{C}$ , and then the elevated MOF temperature was maintained by flowing hot nitrogen through the tank's coil while pulling a vacuum across the MOF bed to remove residual gases.

*Pressurisation* introduces hydrogen into the system up to operating pressure of 25 barg.

*Charging* is the process in which the system is cooled using liquid nitrogen using two methods. The first was direct cooling, recirculating hydrogen through an external liquid nitrogen heat exchanger and into the tank to directly cool the MOF. The second was indirect cooling, flowing liquid nitrogen through the tank's internal coil.

*Discharging* is the process of controlled discharge of hydrogen, heating the MOF tank to desorb hydrogen. This was achieved by flowing ambient compressed air/nitrogen through the tank's internal coil to heat the MOF.

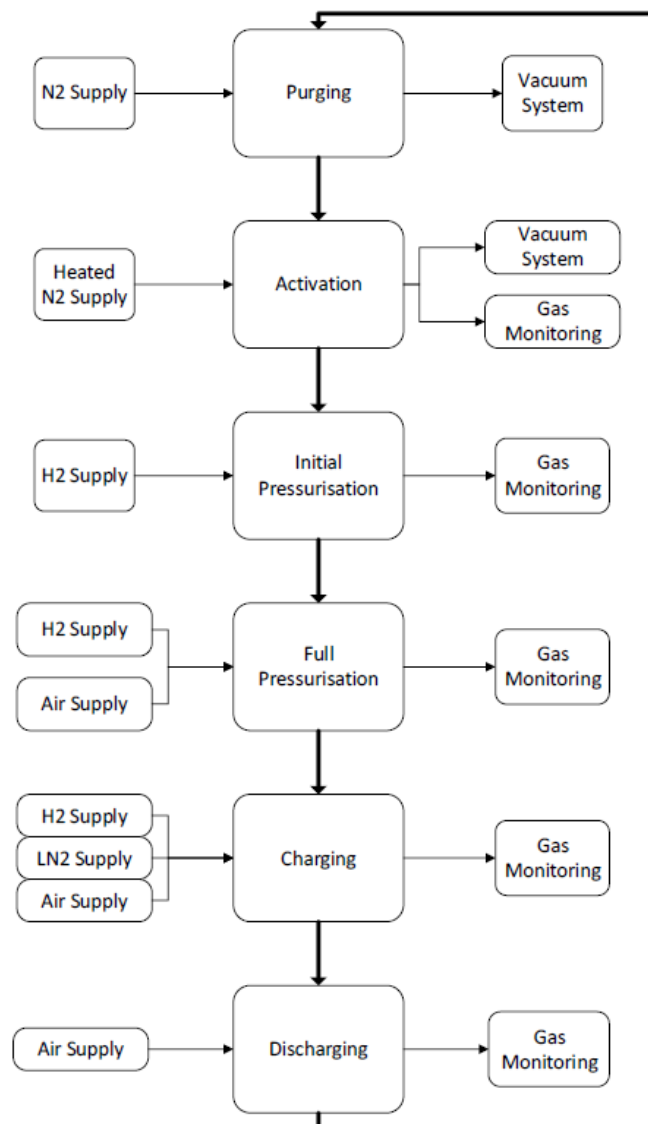

**Figure 5 - Prototype Operations**

The prototypes design was a first iteration on the path to full integration within the demonstrator bus. Therefore, the prototype had the additional objectives:

- To prove the system could discharge at the equivalent demand of a bus by using a mass flow controller to simulate a variable demand on the system's discharge. Project partner Ricardo provided fuel cell mission profiles for the bus, as seen in Figure 6.
- To assess the purity of the discharged hydrogen gas to ensure that the bus's fuel cell is not poisoned using a Residual Gas Analyser (RGA) incorporated into the system on a dedicated sampling line.

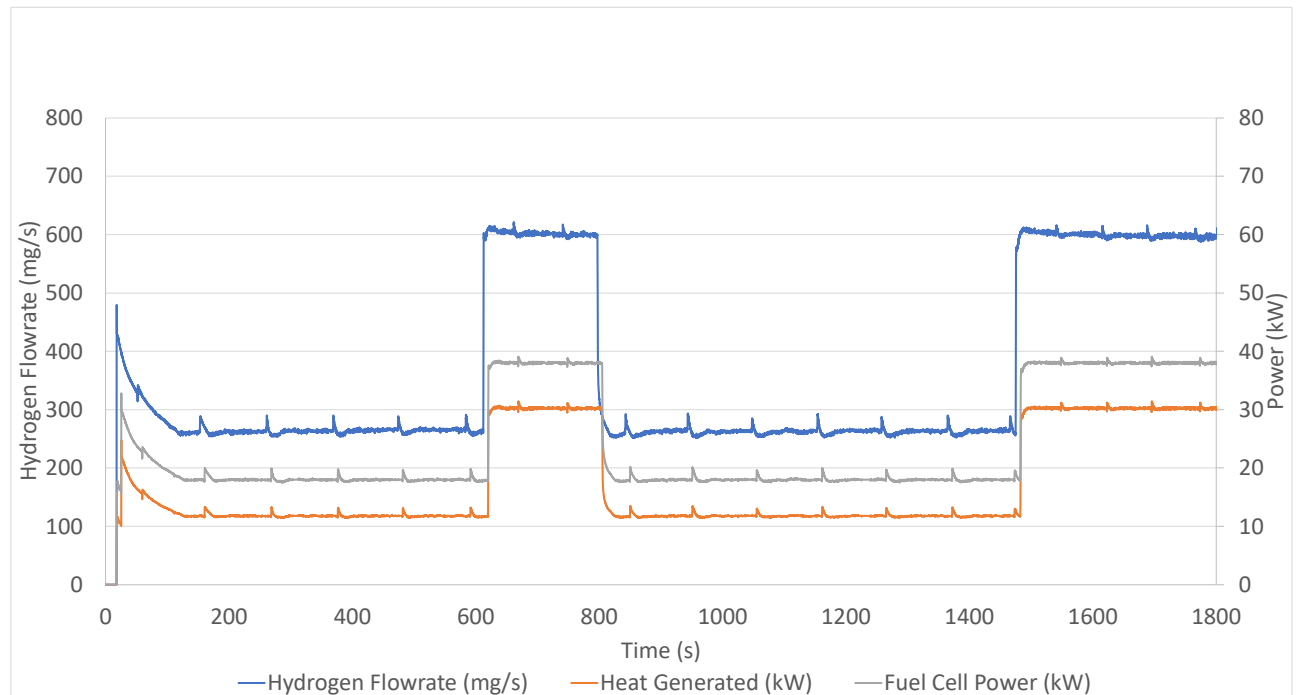

**Figure 6 - Fuel Cell Bus Mission Profile for Prototype Simulation**

To achieve the intent of the prototype testing, the system was designed with the following key features:

- To directly cool the MOF, a LN2 heat exchanger was built in the form of a cryogenic dewar filled with liquid nitrogen containing a coiled copper.
- The direct cooling method relied on the circulation of hydrogen through the LN2 heat exchanger and the MOF bed. It was not feasible to procure cryogenic-capable equipment, so a system was devised to make use of an ambient temperature gas booster. This required the cold hydrogen exiting the MOF tank to be warmed up, allowing it to be pumped back around the circuit and be cooled down to LN2 temperatures. This is obviously an inefficient cooling system, but it allows for the use of standard off-the-shelf equipment to demonstrate the concept.
- The use of mass flow controllers on the inlet and outlets of the system enabled the measurement of the hydrogen inventory in the system and the simulation of the bus demand profile.
- A sample line was tied into the inlet and outlet lines, allowing the gases to be sampled by the RGA.

### 3.3.2.2. Development of the Prototype Tank

The prototype system uses a custom-made MOF tank developed by the MTC. The tank incorporates several key features that are listed below and illustrated in Figure 7.

- Double-skinned vacuum insulation.
- Small ½” tube inlet and outlets.
- Coiled copper pipe for cooling and heating of the inner vessel and MOF bed.
- Integrated RTDs to measure the active temperature across the inner vessel.
- Flexible pressure line at the inlet to the tank to avoid thermal expansion stresses at the fixed points

The prototype MOF vessel design underwent rigorous analysis via simulation of the material stresses as well as modelling of the thermal performance.

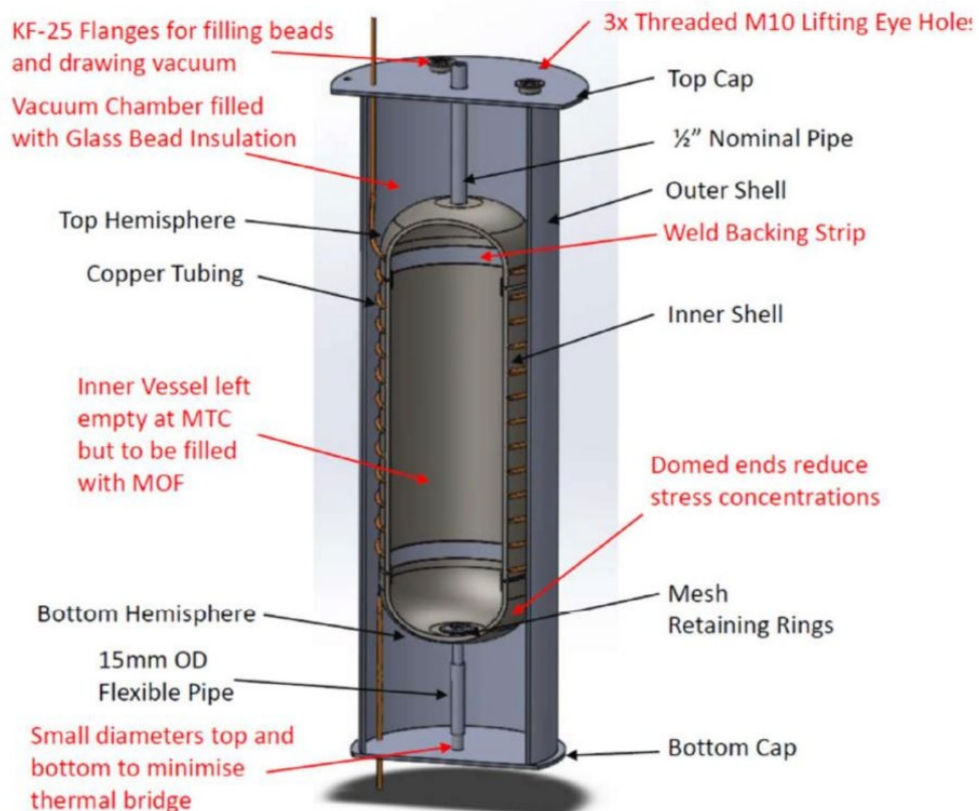

**Figure 7 - MTC Prototype Tank**



**Figure 8 - Prototype Tank Assembly**

The photograph on the left in Figure 8 shows the prototype inner tank, also visible is the integrated cooling and heating coil.

The photograph on the right shows the corresponding outer tank, into which the inner tank is inserted. The outer tank provides structural support, insulation, and an additional layer of containment.

### **3.3.3. WP5 Demonstrator Design and Build**

The demonstrator phase of the project aimed to integrate the developed MOF system into the final application, a hydrogen fuel cell bus. Project partner Ricardo led the modification designs for an existing bus in tandem with Element leading the system design.

The demonstration testing had the following objectives:

- To demonstrate system volumetric capacity.
- To cool the MOF to achieve storage conditions.
- To demonstrate the system is able to cool the MOF, tank walls and stored hydrogen from ambient to  $<-191^{\circ}$  (82K) in 20 minutes.
- To achieve MOF with a particle density of at least  $800 \text{ kg/m}^3$ .
- To pack the MOF into the tank with a void fraction less than 40%.
- The bus must drive for a minimum of 1 hour replicating a realistic city bus route and speed, without venting or fuel cell tripping events.

#### **3.3.3.1. Progression from the Prototype**

The demonstrator system was a 10-fold scale up of the prototype system, capacity increasing from 20 to 200L. The system was similar to the prototype with the following changes:

- 
- The operating pressure of the MOF system was increased from 25 to 40.5 barg to maximise the potential storage capacity of the MOF.
  - The demonstrator had to use the same gas booster as the prototype for recirculation flow as it was not feasible to procure additional boosters.
  - The gas analysis work was completed in the prototype testing, and so the sampling capability of the system was not required.
  - Heaters were added to the discharge system to maximise the desorption from the MOF.

### **3.3.3.2. Development of Demonstrator System**

The design was split into two sub-systems between the vehicle and the ground. As the bus was required to drive, these systems had to operate independently of each other while allowing for safe control throughout all operations.

The vehicle contained the following systems and equipment:

- The MOF tank, the tank enclosure and the supports to secure the enclosure on the bus.
- Piping system.
- Gas detectors and the emergency stop buttons.
- The onboard Data Acquisition System (DAQ).
- Additional batteries to support the MOF system heaters.

The ground system consisted of refuelling equipment, including:

- Hydrogen bottles for supplying the system.
- Nitrogen bottles to supply reactivation and purging activities.
- LN2 dewars and the associated heat exchanger to cool the hydrogen.
- The gas booster and recirculation equipment, including air compressors and dryers.
- Vent systems with built in heat exchangers to ensure any cryogenic gas is vented at ambient temperatures.
- A ground based DAQ to compliment the vehicle DAQ.

The key interfaces between the ground and vehicle systems are the piping system.

### 3.3.3.3. Development of Demonstrator Tank

Building on the learning from the prototype tank, the demonstrator tank was constructed in a similar fashion by Glacier Energy. The tank maintained the key features as a stainless steel construction, housing MOF within an internal vessel, an outer vessel vacuum jacket, and an internal copper coil providing heating and cooling. The main changes to the tank design were as following:

- The tank is scaled up to 200L from the prototypes 20L.
- The outer vessel incorporated domed ends instead of the flat plates.
- There were aluminium fins within the internal vessel, to provide increased heat transfer within the MOF bed to aid cooling and heating.
- An increased inlet and outlet pipe size from ½” to 4” to allow for ease of charging the larger MOF pellets into the tank and to ensure the tank could be filled with MOF around the new internal fins.
- Insertable grates in the inlet and outlet held in place by the flange connections to hold the MOF in place and avoid fluidisation and losses into the downstream system.
- An additional pressure relief line within the boundary of the grates to ensure high pressures were adequately vented in the unlikely event of a reaction.
- An aluminium frame to contain the vessel for securing within the bus and for transport.
- Additional standard vacuum fittings with nominal bore size of 40mm (KF40) were manufactured into the end domes to allow for alternative access or additional vacuum connections to the tank.

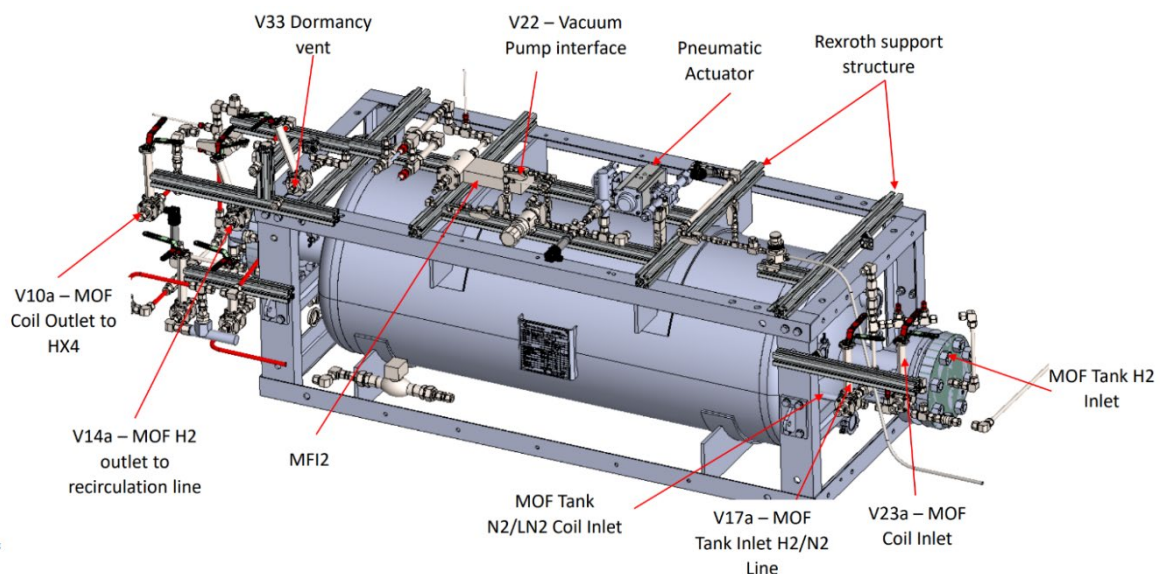

**Figure 9 - Demonstrator Tank with Integrated System**

### 3.3.3.4. System Build

The tank was installed to the rear of the bus lower deck passenger compartment., to avoid unnecessary modification to the bus and its existing fuel system, and to allow full access to the tank and equipment during testing. The installed tank can be seen in Figure 10.



**Figure 10 - Tank (Encircled) Installation on Bus**

The tank is contained within an enclosure, mounted over the rear wheel arch. The hydrogen fuel cell supply line was easily accessible in this location and allowed for access to operate and troubleshoot throughout testing. The tank, frame and equipment were designed to be within the equivalent weight ratings of the 6 seats removed for its installation, plus safety margin.



**Figure 11 - Bus Onboard Installation**

The ground system was built on the edge of the hydrogen testing platform, allowing the bus to be parked adjacent to it and connected. The ground system including valving arrangements, heat exchangers and the flexible piping is shown in Figure 12.



**Figure 12 - Ground System Setup Build**

### **3.3.4. Verification Activities and Testing**

At each stage of the testing, a thorough commissioning and test procedure has been produced and followed. All build and test documentation was reviewed by the Designers, Element, and by Immaterial to ensure that the design is safe and fit for purpose. Safety assessments have been held with a multi-disciplined team to ensure the designs were safe and operable as intended. Commissioning activities verified that all systems and equipment operated as intended before testing.

Throughout each stage the manufactured MOF was subject to Brunauer-Emmett-Teller (BET) to evaluate the available surface area for adsorption. The Brunauer-Emmett-Teller is a scientific method used to measure the surface area of a material. From this, it estimates the specific surface area — typically expressed in square meters per gram ( $\text{m}^2/\text{g}$ ). This is a direct measure of the quality of MOF production and its potential for hydrogen adsorption.

#### **3.3.4.1. Test Rig Results**

The test-rig, as described in Section 3.3.1 was used to perform a cyclic test consisting of the following five steps:

- Pressurisation
- Cool-down
- Dormancy
- Depressurisation
- Heat-up

The test rig system was tested at a range of pressures from 4 bara up to 40 bara. During each experiment, the dormancy period was used to extract the isobars of the MOF, i.e., the amount of hydrogen stored in the MOF at constant pressure while varying the temperature. From these data, a plot of the expected uptake (according to equilibrium models) and the experimentally obtained values was produced (Figure 13). The experiments demonstrated very good reproducibility which is illustrated in the multiple data sets at 25 bar and 10 bar.

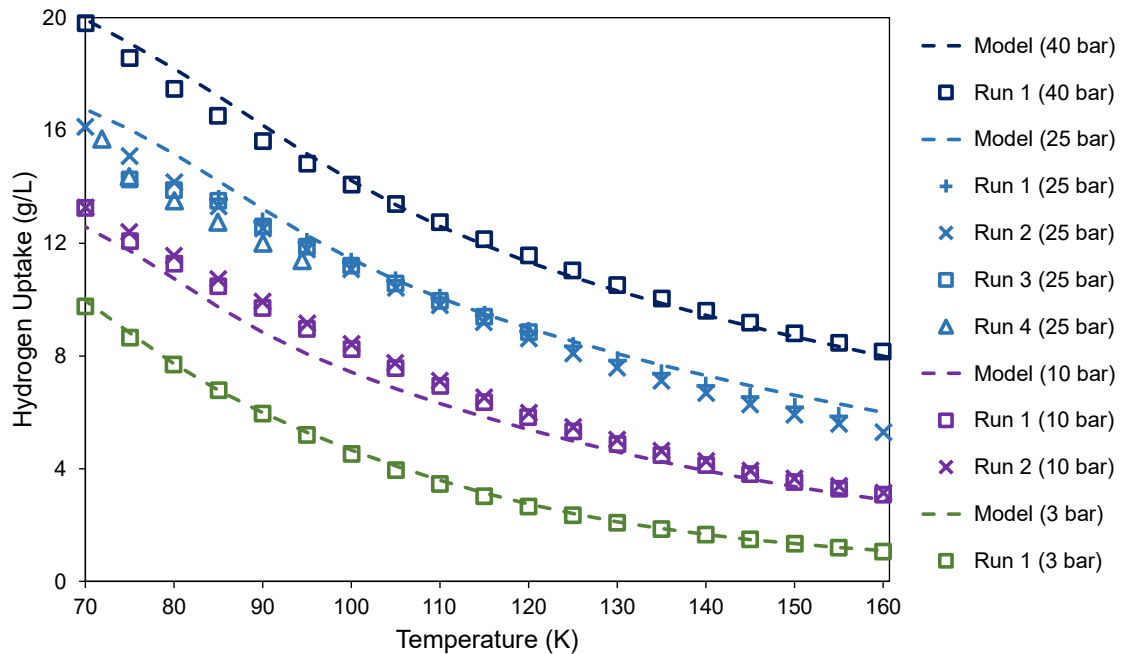

**Figure 13 - Experimentally validated equilibrium model of hydrogen uptake**

The testing achieved a MOF tank capacity at 17 g/L, and identified a number of opportunities to further improve on this value. The packaging and storage of the MOF did not sufficiently protect the MOF from degradation caused by air and moisture. The packing efficiency in the tank was below optimum due to the rough cut finish of the MOF produced by the original bench top production process. All of these opportunities have been addressed through later stages of the project.

At a system level, it was found that as expected, significant quantities of liquid hydrogen were required to operate the system and cool the MOF. Alternatively, liquid nitrogen is available in general abundance and is significantly cheaper than liquid hydrogen. Therefore, the prototype would be designed to use liquid nitrogen as a cooling source.

### 3.3.4.2. Prototype Tests

The first prototype tests took place in August 2024 with a second phase in January-February 2025. The prototype represented the first comprehensive testing of the system at a functional level and provided an opportunity to troubleshoot a range of challenges.

The key insights are as follows:

- **Tank Thermal Performance:** The double skinned tank with vacuum insulation maintained cryogenic temperatures well, producing temperature trends as expected from the simulations. There was minimum heat ingress through the ½” inlet and outlet tubes. In reactivation the tank and MOF did not achieve the lowest target temperatures, it was found that the epoxy used to increase contact area between the internal coil and inner vessel was black and fully covered the coil. The black epoxy increased the emissivity causing higher heat losses via radiation.
- **Direct Cooling:** This method of cooling was significantly quicker than the indirect method. However, it used larger quantities of LN2 than expected and was not able to achieve target MOF temperature with the quantity of LN2 that available on site at the time. A larger inventory was required.
- **Indirect Cooling:** There was insufficient LN2 available to test indirect cooling method in combination with direct cooling. However, it did show that it was capable of cooling the MOF and confirmed that it was the slower of the two methods.
- **Discharge:** The discharge method using ambient air through the tanks coil to heat the MOF did not desorb sufficient hydrogen to maintain a constant system pressure. This was expected and is an area of improvement considered in the demonstrator tank and system design.
- **Hydrogen Volumetric Capacity:** The measured capacity at the achieved average temperature showed to be close to the theoretical isotherm, indicating that the MOF in the system had good performance and had the potential to achieve the target 24 g/l if target temperatures towards -196°C were achieved.
- **RGA Purity Testing:** Progressive testing throughout testing showed that the use of the MOF system did not introduce any contaminants or airborne species that could poison the demonstrator fuel cell. This was the most significant technical risk to the project as it had not been tested previously.

#### 3.3.4.3. Demonstrator Tests

Demonstrator tests and tests results are described in full in Section 4 of this report.

#### 3.3.5. Safety Reviews

Each phase of the system design has undergone thorough safety reviews. This has been delivered in the form of HAZIDs and HAZOPs, where multi-disciplined teams from all designers and Immaterial have systematically reviewed the designs and operation intent to identify potential hazards and recommended mitigations in response to them.

In the prototype stage, these were led internally by Element as the main designer. However, for the demonstrator, another level of independent review was introduced by having Abbot Risk Consulting (ARC) chair the HAZOP.

In addition to the workshop reviews, ARC was commissioned to develop a risk management report and hazard log. The report provided an overview of the current outcomes of the application

of the engineering and safety management system and acts as a single consolidated point of reference for the information associated with and generated by the safety assurance activities for the project.

### **Equipment Specification and Selection**

While the tank and bus modifications were fabricated to design, the majority of the hydrogen system designed and built by Element was constrained to the specification and selection of existing components.

The selection of the majority of equipment followed the standard practice on Element's site to allow for seamless integration with and use of their existing systems and equipment.

Sound engineering principles of the system have been implemented to minimise the risk of a dangerous atmosphere from forming and to mitigate the impact in the event that a dangerous atmosphere does form.

#### **3.3.5.1. Cooling and Recirculation**

The most challenging aspect of developing the prototype and demonstrator system was equipment selection to handle cryogenic gases. The approach adopted in the previous prototype phase provided a feasible approach for the project, but the inefficiency described has adverse effects on the quantities liquid nitrogen required. For the technology to move to successful commercialisation, an appropriate cryogenic recirculation device would be sourced or developed.

#### **3.3.5.2. MOF Heating**

Once cooled and saturated with hydrogen, the MOF requires controlled heating to assist the desorption of hydrogen for discharge to the fuel cell.

The tank already had the copper coil designed to aid in cooling operations and therefore was decided to make use of this coil for heating as the most feasible option.

#### **3.3.6. Control Logic**

The control logic for the prototype and demonstrator systems are fundamentally similar.

The key controlled element is the discharge of the tank which can be controlled by manipulating pressure and temperature. The fuel cell bus to be used has a built-in regulator with a set point mid-range of the tank operation, so the system is configured to be manipulated by changes in temperature.

As the fuel cell demands hydrogen, the available gas in the tank system is consumed, which starts to depressurise the tank. To cause hydrogen desorption and maintain the tank pressure, the tank and MOF are heated. This is achieved by flowing ambient or heated air or nitrogen through the internal coil of the tank, transferring heat into the MOF bed.

Ultimate protection of the system is provided by a series of e-stops built in to ensure that the onboard operators or bus driver can shut down the system at any point. The built-in overpressure

protections are designed to maintain safe conditions in the tank by venting excess gas pressure to a safe location.

Similarly, local gas detectors are installed on the bus. If these are triggered, they isolate the discharge and heating line, and all power to eliminate all ignition sources.

### **3.3.7. Procurement and Fabrication Activities**

The majority of procurement activities for equipment, consumables (LN<sub>2</sub>, H<sub>2</sub> etc.) and third party services were managed by Element as the lead sub-contractor. Glacier managed all procurement activities associated with building the demonstrator tank, and similarly MTC with the prototype tanks.

Immaterial have managed additional procurement that has fallen outside of the agreed scopes of the sub-contractors.

### **3.3.8. Lessons Learnt**

#### **3.3.8.1. Test Rig**

- Packing efficiency is a key determinant of system capacity: System-level hydrogen storage capacity can be significantly impacted, and improving packing efficiency was crucial to achieve higher gravimetric capacities in future prototypes.
- Material quality during storage must be controlled: Analysis of MOF used in the test rig revealed a 30–40% reduction in BET surface area compared to freshly manufactured material.
- Packaging solutions can mitigate material degradation: Extended storage in polyethylene packaging led to significant losses in adsorption capacity, whereas the use of aluminium-polyethylene laminates preserved MOF performance.
- Reactivation can recover performance: Reactivation of MOF using nitrogen flow at elevated temperatures restored the BET area and adsorption capacity, showing that controlled reactivation can mitigate losses that occur during storage.

#### **3.3.8.2. Prototype**

In addition to the key outcomes of the prototype testing, this phase of the project provided additional learning events that were considered within the demonstrator design:

- Two prototype tanks were used in the project. In the first the internal coil was found to have a leak, rendering it inoperable. This was thought to be a combination of the brazing technique used to attach the coil to the internal tank surface, and the vibration required to fill the tank with MOF. This is valuable learning during prototyping.

- In the first prototype tank, glass bubbles were used in the insulation space to provide further insulation. These proved difficult to handle, and added only marginally to performance.
- The second prototype tank used a black epoxy to increase contact between the coil and the internal vessel. This resulted in a significant portion of the internal tank being painted black which is thought to have increased the emissivity of the internal vessel and resulted in significant heat losses



Figure 14 – Prototype (left) and Demonstrator (right) Tank Epoxy

### 3.3.8.3. Demonstrator

Demonstrator related lessons learnt are captured in Section 4.

### 3.3.9. Consents, Permitting Applications and other Regulatory Approvals / Considerations

As a development system it is important to adhere to all regulatory requirements. The use of hydrogen vehicles on roads is currently subject to regulations or standards that are themselves relatively new. The Ricardo bus was previously modified with a hydrogen fuel cell subject to Regulation (EC) No 79/2009, which has since been repealed and replaced by Regulation (EU) 2019/2144.

These regulations apply to driving on public roads but are not required for driving on privately owned roads. Element's test site is located on a privately owned airfield who have provided consent for the bus testing on their premises. So, at this stage of development the new MOF-based system does not need to adhere to all requirements of EC79. Further development for road-use would require additional testing, the majority of the necessary features are easily implemented and would not affect the design or installation significantly.

The support from ARC and use of the risk management report ensures the project considers the necessary safety requirements. Figure 15 illustrates the derivation of the safety management process that considers standards and regulations.

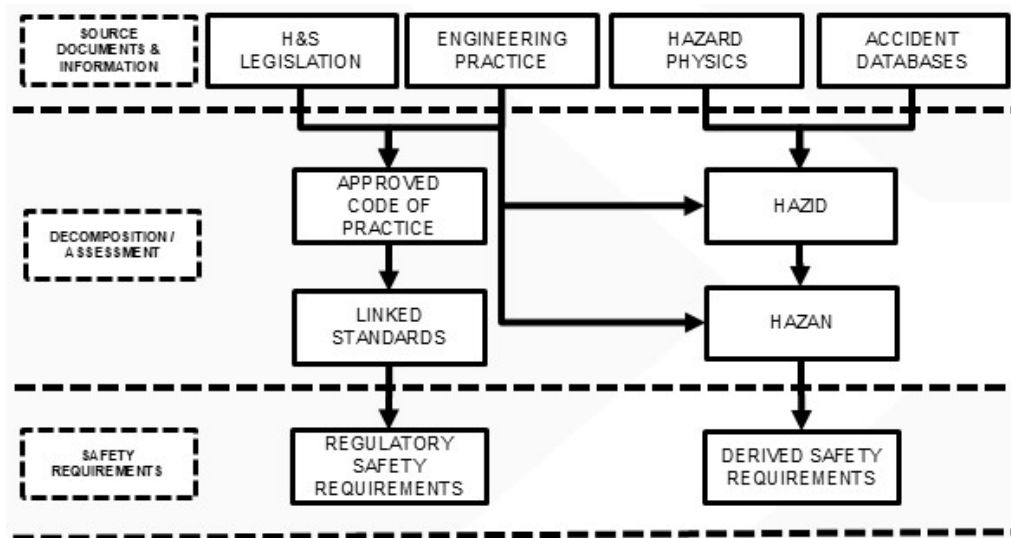

**Figure 15 - Safety requirements derivation**

The principal items of legislation relevant to high-pressure hydrogen gas systems are:

- The Pressure System Safety Regulations (PSSR) and the associated Pressure Equipment (Safety) Regulations 2016.
- The Dangerous Substances and Explosive Atmospheres Regulations (DSEAR).

## 4. Demonstrator Study

The demonstrator study was conducted over a 6 week period from 30<sup>th</sup> June 2025 to 8<sup>th</sup> August 2025 including full functional commissioning work and a series of tests, culminating in a driven demonstration to stakeholders, to obtain all the relevant data to meet the project objectives, as set out in Section 3.3.3.

#### 4.1. Testing Schedule

The demonstration schedule originally planned for the following main test structure:

- Reactivation,
- Dead volume testing,
- Fuel Cell (FC) refinement and reconditioning activities,
- Static discharge testing,
- Driven discharge testing including the demonstration,
- Dormancy.

1 captures the schedule that was delivered throughout testing. The testing window had a hard cut off due to operator availability onsite. Therefore, the testing schedule was modified and adapted as new challenges and troubleshooting arose. Therefore, it was not delivered in the same order as originally planned.

**Table 1 - Demonstration Testing Schedule**

Planned Activities	Purpose of Activity	Outcomes
Reactivation	To remove all contaminants within the MOF adsorbed in build and commissioning since the lab based initial activation.	Partial reactivation was achieved.
Fuel Cell (FC) Reconditioning	The bus's fuel cell is reconditioned after a long dormant period by supplying hydrogen from a bottle source through the MOF system. The MOF system is ambient and passive for this test.	The fuel cell was successfully reconditioned to confirm that the required net electrical output from the fuel cell required for the mission profile could be achieved within its standard hydrogen consumption parameters.
Dead Volume Testing	To evaluate the true system volume using hydrogen gas. The volume is calculated using the mass of hydrogen charged into the system and the system temperatures and pressures.  The test was performed in sections:  1. Fill line, tank and recirculation system. 2. Fill line and tank. 3. Fill line.	The test was successfully completed with multiple repeats. The volumes were calculated and validated by the repeats.
First Cooling Cycle.	The first cooling cycle was to be performed in readiness of the FC Refinement test and was the first attempt to cool the system.	The tank achieved -140°C hydrogen at the outlet FC Refinement testing was delayed.
Cooling Test	Initial cooling cycles were conducted to test the functionality of the system.	With some troubleshooting around the gas booster, a full cooling cycle was achieved.
Coil Cooling Test	A test was conducted to investigate the performance of coil cooling independently.	The test showed that coil cooling does provide some cooling to the tank and MOF but is less effective than direct cooling.

FC Refinement	The refinement test is the first time the fuel cell is supplied by hydrogen desorbed from the MOF.	The FC refinement test concluded that there was sufficient hydrogen in the MOF system to supply the fuel cell for the driven mission profile.
Initial Dormancy Test	An initial dormancy test on the back of a cooling cycle to evaluate the total hydrogen storage within the MOF system.	This test achieved a volumetric capacity that was expected due to the tank being warmer than target temperature.  Further tests were planned to improve system cooling by manipulating the use of the gas booster and system pressures to achieve higher flowrates around the recirculation loop.
Driven Demonstration	To demonstrate the operation of the system on the hydrogen fuel cell bus to stakeholders.  Complete the one-hour mission profile using the MOF system to supply hydrogen to the buses fuel cell to produce electrical power.	The driven test was completed without fault and successfully proved that the MOF system supplied the fuel cell with sufficient hydrogen to complete the full mission profile.
Cooling Optimisation	In an attempt to obtain the best possible data from the final test the system was optimised to reduce heat losses and improve the operation of the recirculation systems by manipulating the gas boosters operation.	Work was completed ahead of final testing.
Final Cooling From Ambient	To obtain the best cooling data, a final test was conducted from fully ambient conditions.	The increased flowrate through the booster achieved significantly better cooling times (by approx. a third), and more uniform tank temperatures.
High Pressure Dormancy (Pressure Varied Discharge)	The final test aimed to achieve the best possible conditions within the MOF tank and to measure the full mass of hydrogen desorbed and discharged from the MOF system via the dormancy line.	The test achieved its best ultimate temperatures using the higher gas booster flowrates.  The volumetric capacity was significantly improved and measured at 20 g/l.

## 4.2. Test Results

### 4.2.1. Reactivation

In the final stage of production, the MOF is activated in vacuum ovens to remove any gases or moisture adsorbed through production. However, the MOF is further exposed to air during the tank filling process and tank installation into the demonstrator system, despite measures to minimise this.

The MOF therefore requires an in-situ reactivation to remove these new impurities and ensure the MOF pores are free for hydrogen adsorption.

Figure 16 illustrates the achieved tank temperatures of the first (blue/top) and second (orange/bottom) reactivation attempts.

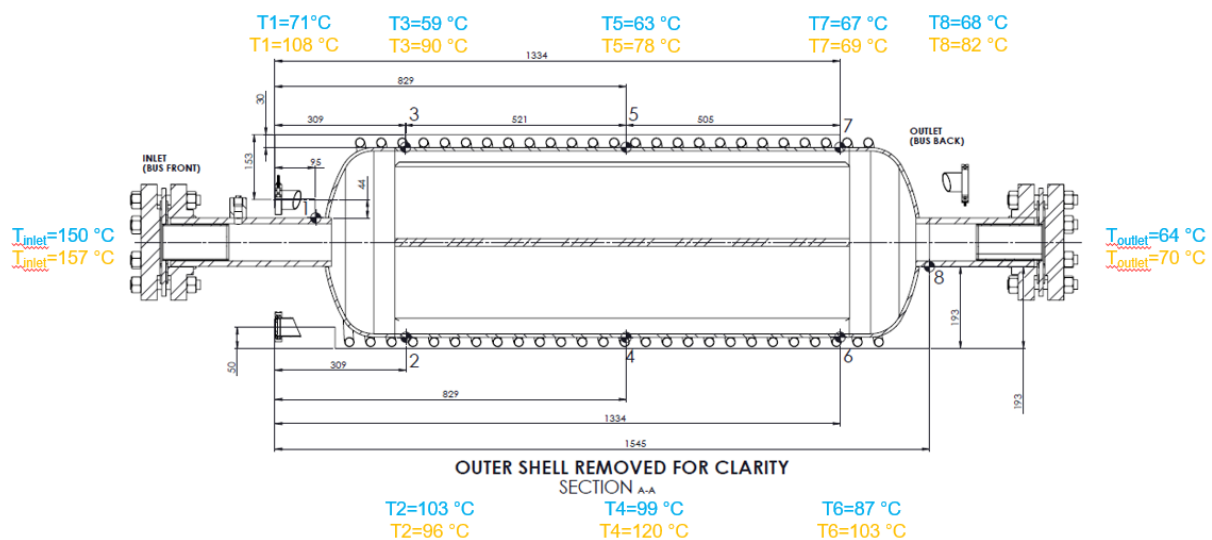

**Figure 16 - Tank Reactivation Temperatures**

The maximum achievable temperatures of the MOF tank were limited by heat loss from the tank, and by the maximum to which the inlet nitrogen could be heated.

The MOF was therefore partially reactivated, but as it did not achieve temperatures towards 160°C it is expected that trace amounts of impurities may have remained in the MOF, which could limit the performance.

### 4.2.2. Cooling

#### 4.2.2.1. Direct Cooling

Direct cooling is the primary method for achieving cryogenic temperatures in the MOF tank.

Figure 17 and Figure 18 illustrate the first cooling cycle from ambient temperature and the equivalent final cooling cycle. The two temperatures are those of the hydrogen entering and exiting the tank during cooling. The cooling process was continuously improved throughout

testing with specific improvements made to vacuum insulation, management of system pressure, improved control of recirculation flow rate, and improvements to the system piping.

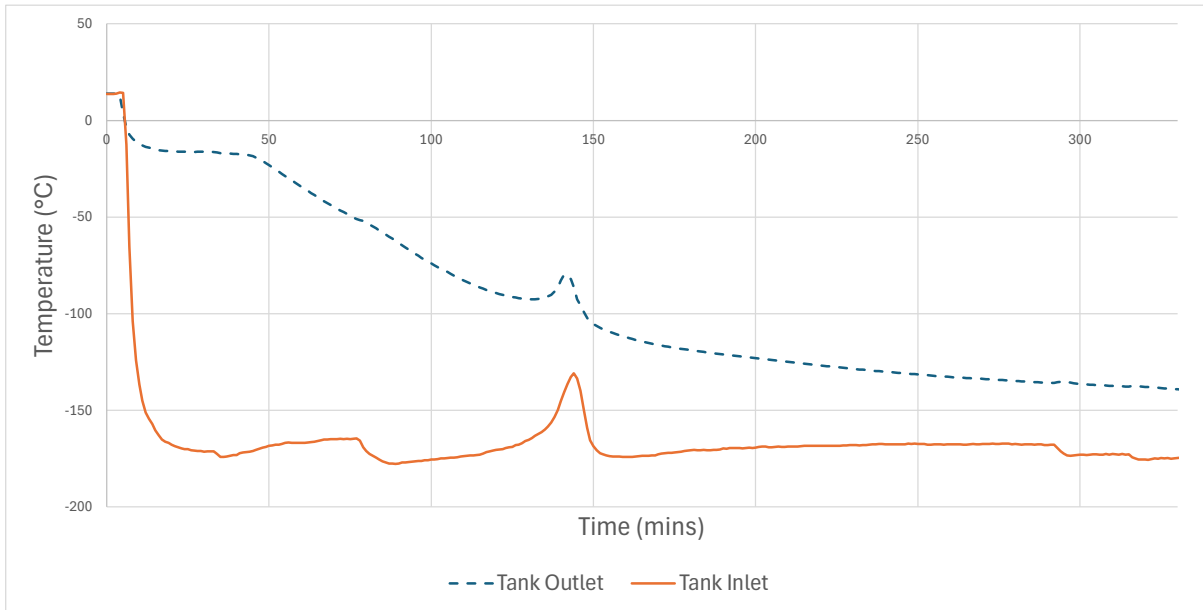

**Figure 17 - Initial Cooling Cycle**

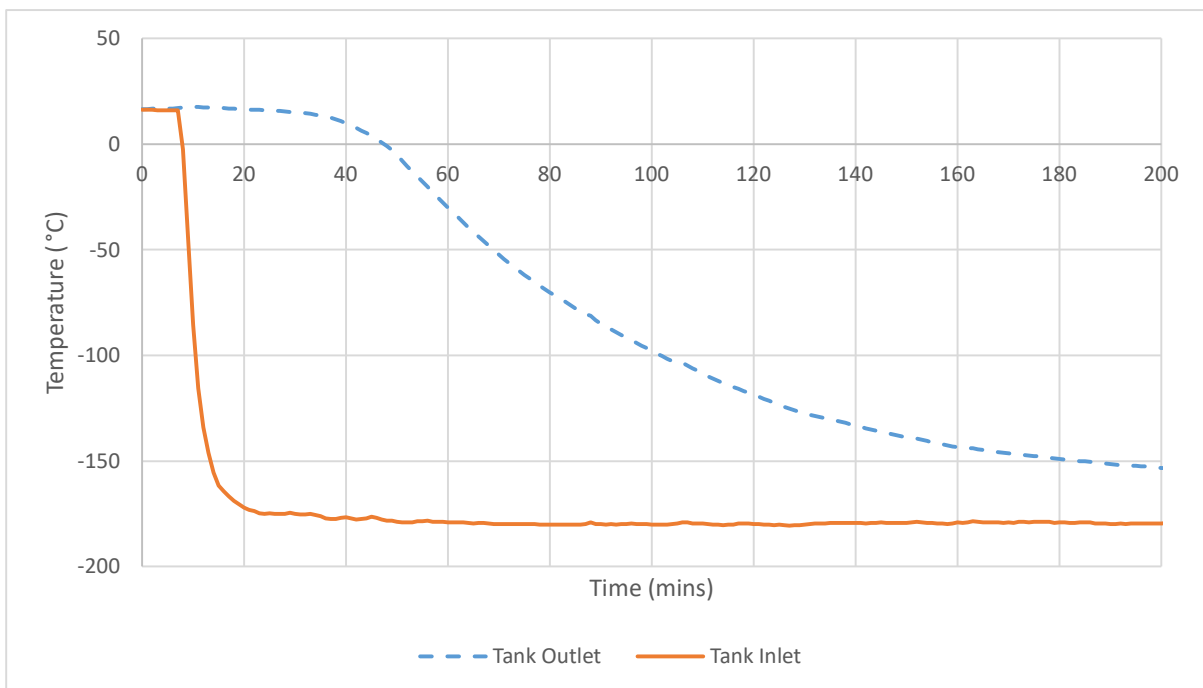
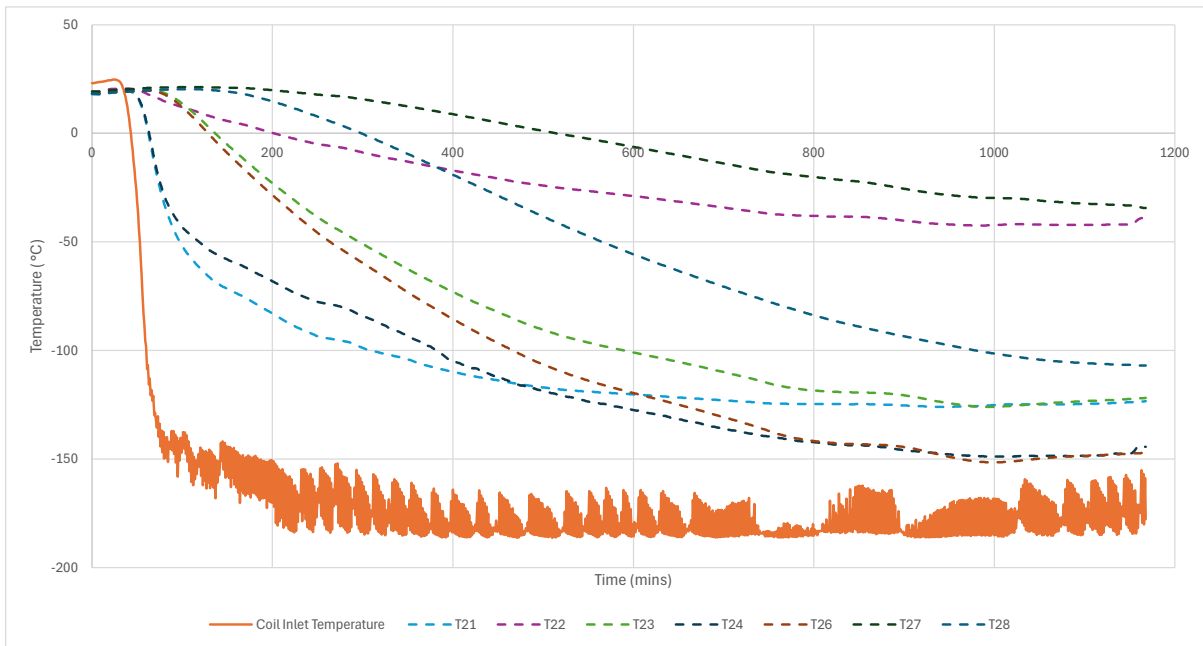

**Figure 18 - Final Cooling Cycle**

#### 4.2.2.2. Coil Cooling

The purpose of coil cooling was to be used at the end of direct cooling in parallel to further decrease the MOF temperature.

A opportunity was taken to investigate coil cooling to show its capability. Figure 19 illustrates how the coil clearly cools the tank, but over significantly longer time than the direct colling method.



**Figure 19 - Coil Cooling from Ambient**

#### 4.2.2.3. Ultimate Temperature Improvements

Figure 20 illustrates the difference in tank temperatures of the initial cooling cycle (blue) compared to the final cooling cycle (orange). Note that the RTD labelled T5 failed early in testing and did not produce useable data.

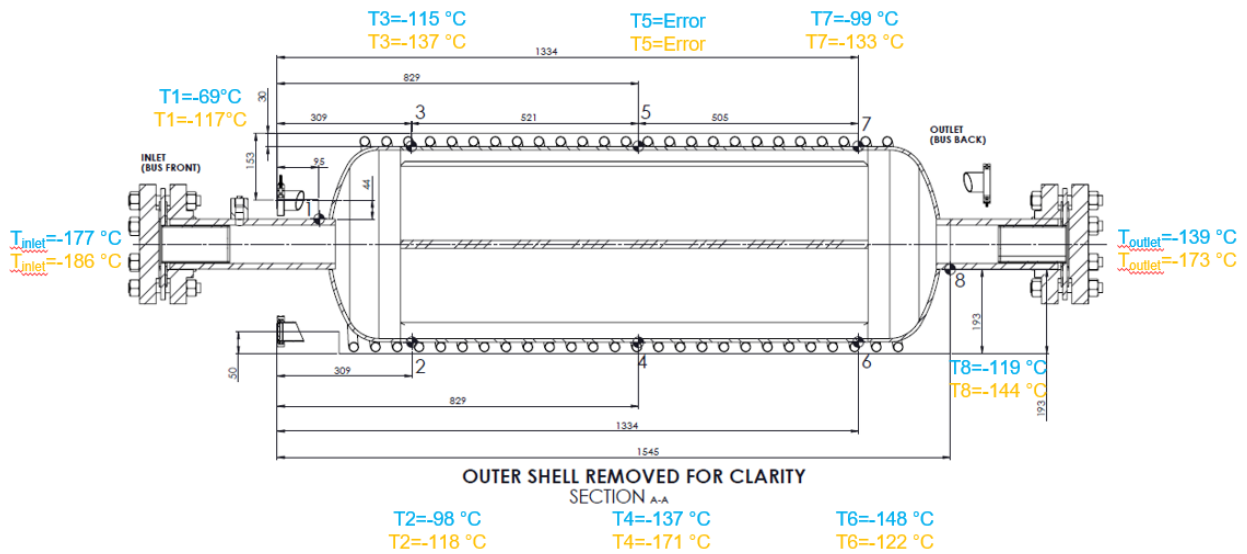

**Figure 20 - Improvements to Cooling Temperatures from Initial (Blue) to Final (Orange) Cooling Cycle**

During initial cooling, ice build-up was observed on the tank. Before the vacuum pump setup was improved, ice formation could be seen across the length of the tank cylinder. See Figure 21.

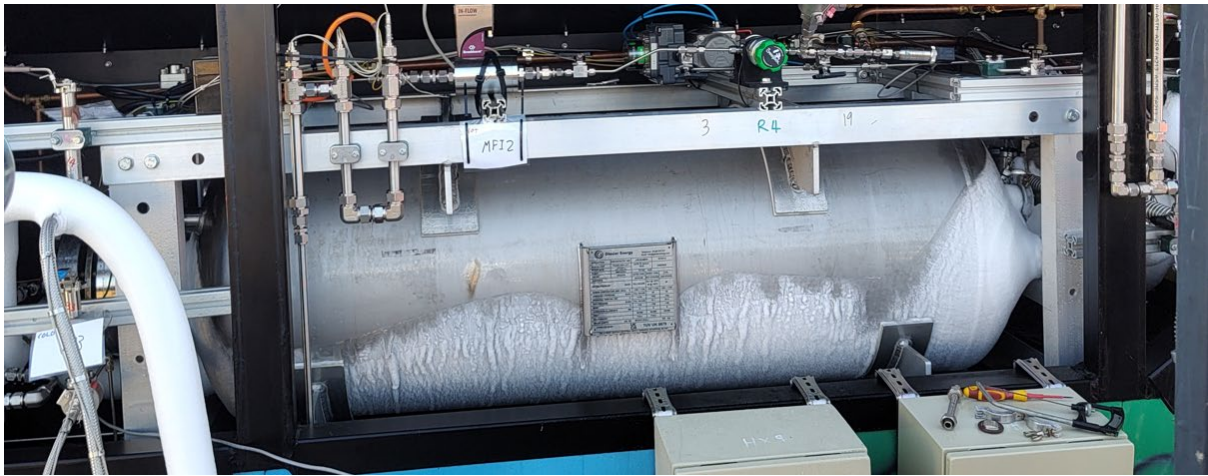

**Figure 21 - Tank Ice Formation Pre-Vacuum Jacket Improvements**

Once the vacuum was improved the ice formation only formed on the inlet and outlets of the tank, as seen in the circled sections in Figure 22.



**Figure 22 - Tank Ice Build**

## LN2 Consumption

The improvements to cooling times across the tests resulted in more efficient consumption of LN2 that could not be previously tested with the prototype system.

A comparison of LN2 consumptions can be seen in Table 2. The natural boil-off of LN2 from the heat exchanger dewar was measured as a baseline.

In repeated tests, lower system pressures could be acceptable to achieve approach temperatures before the system pressure is increased for lower ultimate temperatures.

A comparison has been provided for the LN2 consumption when using the coil to cool the MOF. The flowrates through the coil vary significantly, affected by ambient temperature, LN2 supply ullage pressure and pressure variation likely due to the multiphase nature of the flow.

Table 2 - LN2 Consumption

Consumption Method	LN2 Consumption	Mass Flowrate (g/s)
Natural Boil-off	3.1 kg in 90 mins	0.57
11 barg System Pressure	9 kg in 5 mins	30
18 barg System Pressure	14.5 kg in 5 mins	48.3
Coil Cooling	-	5.9

#### 4.2.3. Driven Discharge Test (Demonstration)

The driven test successfully completed the 63.5 minutes mission profile fuelled by the MOF system. The driven test was conducted on privately owned land that implemented a speed limit of 20 mph and was designed to imitate a city bus route, with continuous acceleration and deceleration. This required an average net power supply from the fuel cell of ~11 kW.

On completion of the 63.5 minute mission profile, the bus was parked and a static test was continued for an additional 51.4 minutes. The static test continues to consume hydrogen and produce power at a constant 20 kW, but as the bus is not driven, this is stored fully within the onboard battery.

The test was terminated when the MOF system was depleted of available gaseous hydrogen.

#### Discharge Control

The prototype testing had previously highlighted the challenge of the temperature-based discharge control and so the demonstrator tank had additional internal aluminium fins to increase the bulk conductivity within the tank, and heaters were also installed on the discharge system so that the temperature of the nitrogen heating the tank via the coil could be increased up to 60 °C from ambient.

In the driven demonstration the system achieved good temperatures in cooling. Figure 23 illustrates that the tank pressure was maintained by the control system for a period of approximately 15 minutes during discharge to the fuel cell (375-390 mins).

This method has shown it can work and there is potential for it to be further improved as the MOF is cooled closer to the target temperature.

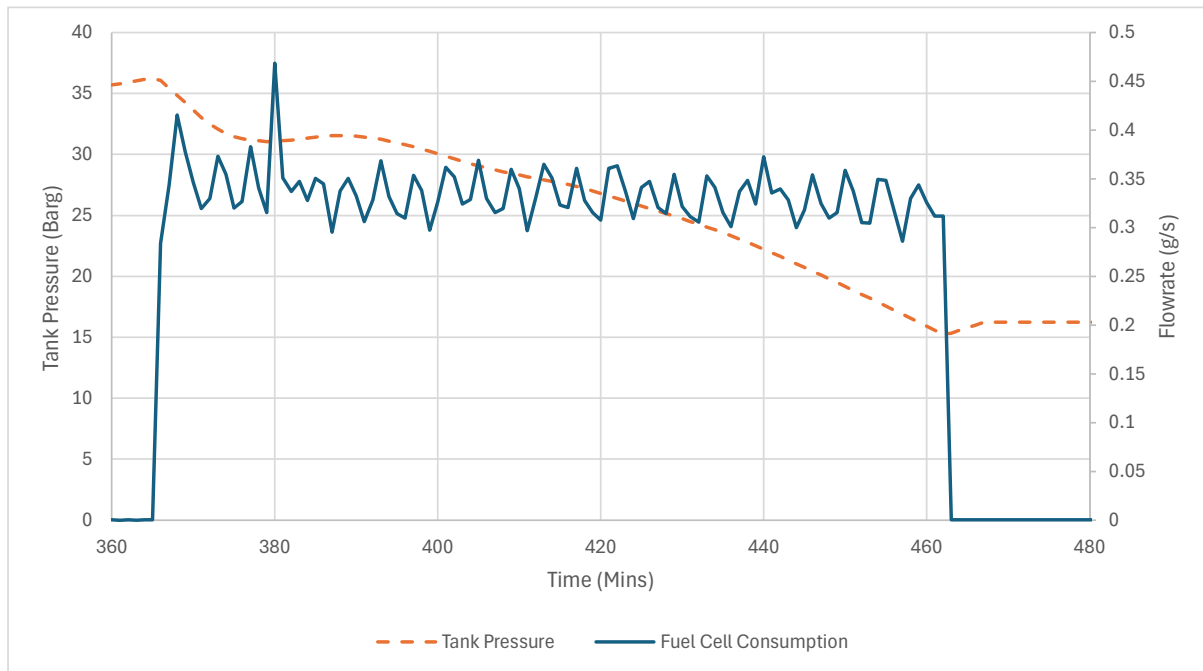

**Figure 23 - Tank Pressure vs FC Consumption**

#### 4.2.4. Expected vs Delivered Volumetric Capacity

##### 4.2.4.1. Dormancy

The final test was devised as a higher pressure dormancy test, achieving the coldest temperature in the MOF using all the improvements identified throughout testing determined as  $-173^{\circ}\text{C}$  based on the tank outlet temperature. It is possible that the average MOF temperature is lower than this.

The dormancy test measured the discharge of hydrogen via a vent line using an MFI from operating pressure down to atmospheric vent pressure. Accounting for residual hydrogen gas remaining in the system, the system held 3683g of hydrogen. Note that the MOF would still contain a small amount of adsorbed hydrogen at ambient conditions which cannot be desorbed without reactivation.

##### 4.2.4.2. Volumetric Capacity

The measured volumetric capacity of the system is therefore 20 g/l.

This value is lower than the project target of 24 g/l. However, this lower value was expected as the MOF was not cooled to the target temperatures, reducing its capacity for adsorption.

The performance of the MOF is compared to the isotherm at the achieved temperature and shows good agreement.

The higher target capacity can be achieved by further improvements to thermal insulation and to in-situ re-activation.

## Objectives Review

The objectives below have been reviewed to assess how well they have been achieved by the project, and to identify further improvement opportunities:

Achieve a system volumetric capacity greater than 24 g H<sub>2</sub>/L.

- The system achieved a volumetric capacity of 20 g/L due to the thermal limitations of the system and tank design, and partial reactivation. These aspects can be improved, which would enable the system to achieve the target capacity.

Cool the MOF to -191° (82K) or lower to achieve storage conditions.

- The lowest temperature measured within the MOF tank was -173°C. Therefore, it is likely that the average MOF temperature was higher than this. The system had thermal limitations as above that can be addressed and improved in future iterations or changes of application.

Manufactured MOF with a particle density of at least 800 kg/m<sup>3</sup>.

- The improved production methods achieved particle densities of 880-950 kg/m<sup>3</sup>.

Pack the MOF into the tank with a void fraction less than 40%.

- The MOF tank achieved a void fraction of 37%.

Drive the bus for a minimum of 1 hour replicating a realistic city bus route and speed, with zero venting or fuel cell tripping events.

- The demonstration driven test achieved the full 1-hour mission profile (63.5 mins completed), and an additional 51 minutes of static discharge charging the bus battery.

### 4.3. Lessons Learnt

The key learnings from the demonstrator testing compliment the test analysis:

- The system was hindered by thermal losses in heating and cooling. The tank design can be improved by modifications such as reducing the inlet and outlet diameters and achieving higher insulation vacuums.
- The tank cooling time and uniformity are affected by the gas flowrate through the tank.
- The ultimate temperature of the MOF is limited by the inlet hydrogen temperature into the tank, which is subject to significant heat ingress over the length and complexity of the piping.
- The internal fins of the tank likely hinder uniform heating/cooling more than it improves the bulk thermal conductivity for discharge control.
- Activation can be performed using recirculated batch volumes of nitrogen using the cooling system.
- Some design limitations associated with application on a bus can be more readily overcome in static application.

---

## 5. Project Metrics

### 5.1. TRL at Start and End of the Project

At the start of the project, the technology was assessed at Technology Readiness Level (TRL) 4 – *Technology validated in lab*. By the end of the project, it was expected to reach **TRL 6** – *Technology demonstrated in a relevant environment*, reflecting significant progress in system development, integration, and validation under conditions representative of real-world application. TRL 6 has been achieved in this project.

### 5.2. Delivered price of Hydrogen

In this report we have used the Levelised Cost of Hydrogen (LCOH) as a metric that includes both fuel cost and onboard efficiency. This metric includes the hydrogen cost, cost of delivery to the storage system and cost of releasing hydrogen to fuel cell (for vehicle application) or any other receiving system.

The figures presented below are based on a projected production scale of 10,000 tanks per year. For these calculations, a hydrogen cost of £2/kg has been applied, in line with the value reported in the IEA Global Hydrogen Review 2021 [3].

LCOH for 10,000 MOF tanks / year is calculated as £3.79/kgH<sub>2</sub>

LCOH for 10,000 350-bar tanks/ year is calculated as £3.01/kgH<sub>2</sub>

The difference in cost can readily be closed by implementing the improvements identified to thermal management of tanks, and by the use of charging and discharging equipment that is specifically designed for purpose, rather than being limited to items off the shelf. Achievement of the initial target 24 g/L alone will offer a 20% reduction in the per kg storage cost.

### 5.3. Hydrogen Storage and Handling Parameters for Demonstration

- *% purity required for input and % purity of output, storage conditions (temperature, pressure, physical form of hydrogen, energy requirements in kWh/kg H<sub>2</sub>); release rate (kgH<sub>2</sub>/day); volumetric H<sub>2</sub> density (kgH<sub>2</sub>/m<sup>3</sup>; gravimetric H<sub>2</sub> density wt%) [yes]*

The bus fuel cell system requires a hydrogen purity of greater than 99.97%. Standard BOC high purity hydrogen products supply hydrogen at 99.99%. The prototype system investigated whether the MOF produced contaminants which could poison the fuel cell. No contamination was observed, nor was there any observable reduction in the fuel cell efficiency during operation with the MOF system.

The systems volumetric capacity was measured at 20 g/l, below the target of 24 g/l due to the limitations in the system thermal performance and the partial reactivation of the MOF. Improving these factors would result in greater MOF capacity.

#### 5.4. Global Warming Potential and GHGs mitigated

For a final commercial product rolled out as expected, the total life cycle Global Warming Potential (GWP) is estimated as 75.453 t CO<sub>2</sub>e to store a total of 12.819 t of hydrogen per tank. This equates to  $7.5453 \times 10^{-5}$  MtCO<sub>2</sub>e/year for one tank at 10,000 MOF tanks per year production.

Figure 24 shows the contributions to the overall GWP of the three phases included in this study: synthesis phase or tank manufacturing, use phase and disposal. The environmental impact of the MOF tank is dominated by the use phase.

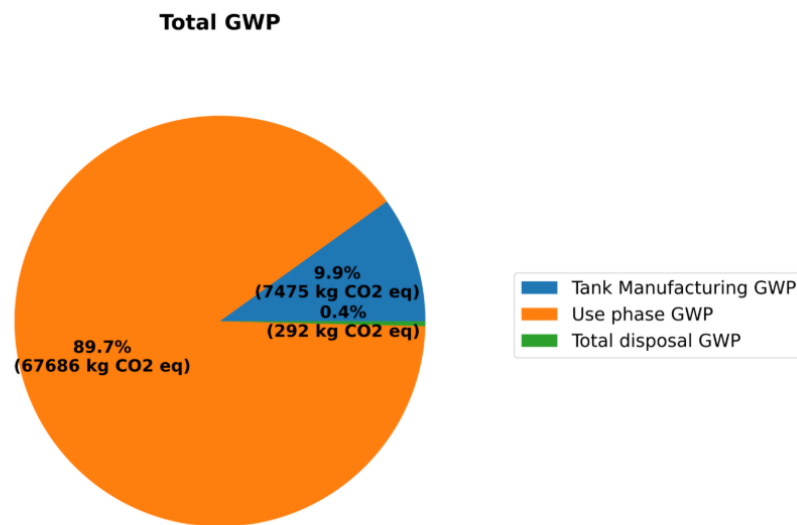

**Figure 24 - Contributions to GWP for the three phases considered in the LCA study**

Based on the analysis, the MOF tank technology demonstrates significant greenhouse gas (GHG) mitigation potential compared with conventional diesel technology. Using IPCC database [6], diesel-powered heavy-duty vehicles emit approximately 0.78 kg CO<sub>2</sub> eq/km, whereas the hydrogen demonstrator bus equipped with the MOF tank emits only 0.10 kg CO<sub>2</sub> eq/km. This represents an 87% reduction in emissions per kilometre compared to diesel. On a yearly basis, the MOF bus mitigates around 35,784 kg CO<sub>2</sub> eq, equivalent to the annual emissions of about four diesel vehicles. Over a 10-year operational lifetime, the MOF bus would prevent the release of roughly 358 tonnes CO<sub>2</sub> eq, highlighting the substantial environmental benefit of adopting MOF-based hydrogen storage systems for public transport applications.

#### 5.5. Potential hydrogen storage capacity for demonstrator and final commercial product

For the demonstrator, a total of 3.68 kg of hydrogen storage was achieved. This is lower than the estimated capacity of 4.9 kg per tank (calculated as 19.7 kg ÷ 4 tanks) projected for a MOF bus. The shortfall is primarily due to thermal limitations of the system.

At a commercial production scale of 10,000 MOF tanks per year, each bus can store a total of 19.7 kg of hydrogen across 4 tanks. Considering the lower heating value (LHV) of hydrogen, where 1 kg H<sub>2</sub> corresponds approximately to 33.33 kWh, the total energy stored per bus can be calculated as follows:

1 kg of H<sub>2</sub> ≈ 33.33 kWh (LHV)

KWh/year = kg H<sub>2</sub>/year × 33.33

19.7 × 33.33 = 656.6 KWh/year per MOF bus

For comparison, 10,000 conventional 350-bar compressed hydrogen tanks, installed on buses stores approximately 676.7 kWh/year per bus across 5 tanks. This demonstrates that the MOF tank system achieves a hydrogen storage capacity broadly comparable to the conventional compressed gas alternative.

## 6. Secondary Project Benefits

### 6.1 IP generated from project

Patent application WO2024241066 (plus related applications) was filed to cover the properties and characteristics of a high bulk density/high storage capacity compositions based on MOF extrudates for use in a gas storage vessel. The MOF material developed by Immaterial for the large-scale testing was covered by this patent application.

### 6.2 Dissemination activities

The HySupply project has actively pursued a diverse and impactful programme of dissemination and knowledge exchange to maximise awareness, build stakeholder engagement, and prepare the market for future commercialisation of Immaterial's cryogenic *m*-MOF hydrogen storage technology. Over the course of the project, we have co-produced and participated in over 15 national and international events dedicated to sharing insights and technical progress with relevant industry, academic, and policy audiences. These include high-visibility exhibitions such as Climate Tech London (2023) and Innovation Zero London (2024 and 2025), where our hydrogen technology was showcased in the Innovation Gallery, as well as the Hydrogen Europe platform through which our technology was presented to a broad pan-European hydrogen audience.

In parallel, team members directly involved in the HySupply project have engaged in targeted knowledge exchange events across multiple geographies, including European Hydrogen Week in Brussels, the Hydrogen Technology Expo in Bremen, Utility Week Live in Birmingham, and CERA Week in the United States. These engagements have supported bilateral dialogues with potential customers and collaborators across mobility, energy, and heavy industry sectors. In addition, participation in programmes such as the Innovate UK Global Business Innovation Programme in South Korea and the UK–Basque Trade Mission further embedded our presence in international ecosystems of innovation.

We have also cultivated deep engagement through ongoing participation in technical working groups, industry consortia, and knowledge networks. Immaterial is an active member of Hydrogen Europe and the Clean Hydrogen Technology Alignment Cooperative (CHyTAC), regularly contributing to webinars, regulatory workshops, and thematic working groups. We are engaged with the UKCCSRC for cross-sector knowledge sharing, and in discussions to join the UK Aggregated Hydrogen Freight Consortium (AHFC).

Beyond events, the project has also generated impactful communication products to support education and outreach. These include a professionally produced educational video on cryo-adsorbed hydrogen storage, and a strategic update of the Immaterial website to highlight our hydrogen technology offering. Further dissemination products are in development, including a technical white paper scheduled for release following the completion of our demonstrator testing, which will consolidate learnings and performance data to inform commercial engagement.

Collectively, these dissemination activities have significantly elevated the visibility of the HySupply project and positioned Immaterial's *m*-MOF storage solution within the hydrogen innovation landscape. They have not only helped to build demand-side awareness and de-risk future market adoption but also fostered partnerships that will be instrumental in scaling up the technology post-demonstration.

## 7. Project Management

### 7.1. Key risks and mitigations, and detail of any risks that materialised into issues

- **Risk:** H<sub>2</sub> purity at prototype or demonstration phase is not sufficient for use in an appropriate fuel cell.  
**Mitigation:** No evidence of MOF poisoning was observed throughout the course of demonstrator testing.
- **Risk:** MOF degrades during storage, handling, transport, or filling to tank.  
**Mitigation:** This has been carefully monitored throughout the project. New aluminium, vacuum-sealed packaging was introduced to protect the MOF during storage and transport.
- **Risk:** Not achieving full activation temperature across the tank.  
**Mitigation:** This risk materialised during testing, where temperature monitoring showed that reactivation temperatures were not achieved, and variations were seen across the tank. The failure to fully achieve reactivation will have impacted performance in the demonstrator testing.
- **Risk:** MOF tank failure (vacuum jacket).  
**Mitigation:** Throughout the prototype and demonstrator, the vacuum jackets have been reasonably effective but have required continuous pumping. The root cause of this issue has not been identified and would be addressed in future tank designs.

- **Risk:** MOF filling insufficient leading to gas channelling  
**Mitigation:** The demonstrator testing did suggest some initial gas channelling in the early tests however, improvements to the system flowrates improved the distribution.
- **Risk:** Discharge system is unable to cause controlled desorption of hydrogen from MOF bed.  
**Mitigation:** The discharge system showed some limitations that would be addressed in subsequent engineering development.

## 8. Commercialisation Plans

### 8.1. Route to Market

The route to market for Immaterial Ltd's cryogenic monolithic *m*-MOF hydrogen tank has been shaped through a combination of techno-economic analysis, stakeholder engagement, feasibility evaluation, and practical field demonstrations. The process has focused not only on assessing where hydrogen storage is needed today, but also where it can deliver disproportionate impact in the future, particularly in segments where current technologies fall short.

Given the modularity, safety, and volumetric efficiency of Immaterial's cryogenic tank system, the aim has been to identify application domains where these attributes create unique value, either through infrastructure cost savings, space efficiency, or improved operational safety.

From this process, two priority sectors have been identified for near-term commercialisation: hydrogen mobility, and industrial hydrogen storage for process decarbonisation. Additional opportunities such as bulk transport, long-duration energy storage, and off-grid applications are under consideration for future alignment. The following sections explore each focus area in turn.

### 8.2. Hydrogen in Mobility: From Commercial Buses to Rail and Heavy-Duty Off-Road Vehicles

Hydrogen mobility initially emerged as a key application for cryogenic *m*-MOF tanks, especially in public transport. Immaterial's demonstration in a fuel cell electric double-decker bus validated the technology's performance, safety, and integration benefits offering longer range, rapid refuelling, and simplified depot infrastructure. However, the commercial landscape has shifted since the project was initially conceived. With battery-electric buses expected to make up over 70% of new fleet purchases by 2030 in many regions, including the UK, hydrogen's near-term opportunity in this space is now limited to longer-range, rural, or niche applications.

This shift is further reinforced by broader market contraction across hydrogen infrastructure. In 2024, more than 20% of announced hydrogen projects across Europe were cancelled or placed on hold [5]. High-profile UK examples include Air Products' cancellation of its £2 billion ammonia import terminal at Immingham, citing weaker demand signals, and ScottishPower's decision to pause several green hydrogen developments despite securing subsidies, pointing to uncertain

offtake and challenging economics. These trends underscore the need for hydrogen technologies to compete not just on cost but on performance and fit-for-purpose deployment.

As the market adapts, hydrogen's strongest mobility potential lies in sectors where batteries fall short due to weight, volume, or operational demands. These include regional and non-electrified rail networks, heavy-duty construction, mining vehicles, and long-haul freight. In these use cases, the compact, modular, and low-pressure design of Immaterial's cryogenic *m*-MOF tanks offers distinct advantages, potentially delivering up to 34 g/L volumetric capacity. With the global hydrogen mobility market projected to exceed £94 billion by 2030, targeting high-density, hard-to-electrify mobility segments positions Immaterial at the forefront of this emerging growth frontier.

While the current LCOS and LCOH for *m*-MOF tanks are slightly higher than those of incumbent 350-bar systems, commercialisation plans remain viable in strategically aligned segments. Our commercial focus is now on applications where compact footprint, operational safety, and system-level benefits outweigh capital cost alone. In sectors such as intermittent storage, *m*-MOF tanks provide advantages that compressed or liquefied systems cannot replicate. These include improved volumetric energy density, reduced permitting complexity, and lower infrastructure risk. As production scales and design is further refined, cost reductions are expected, improving competitiveness over time.

### **8.2.1. Buses**

Hydrogen buses remain critical for zero-emission transit in cities prioritising air quality and range. Operators like TfL, Wrightbus, Caetano, and ADL are expanding deployments in the UK and Europe. *m*-MOF tanks can boost range by 15–20% or reduce storage volume to free space for passengers. Lower operating pressure improves depot safety and cuts refuelling infrastructure costs by up to 30%, making the tanks ideal for urban routes.

### **8.2.2. Rail**

Hydrogen rail enables decarbonisation of the 40% of European railways that remain unelectrified. Fuel must be carried onboard within tight space and weight limits. *m*-MOF tanks support extended range and reduce carriage volume compared to 350-bar alternatives. OEMs like Alstom, Stadler, and Siemens are active in this market, with hydrogen rail projected to exceed €3 billion in Europe by 2030.

### **8.2.3. Truck**

Hydrogen trucks are gaining traction for long-haul freight, with OEMs such as Daimler, Hyundai, and Volvo leading pilots in Europe and North America. *m*-MOF tanks provide modular, dense storage at low pressure, enabling a significantly higher grams per litre working capacity, translating to up to 1,000 km of driving range depending on configuration. For logistics depots, the technology offers safer, more efficient refuelling compared to compressed systems.

#### 8.2.4. Refuelling Infrastructure

As hydrogen mobility expands across road, rail, and off-road sectors, refuelling infrastructure must evolve to support safe, efficient, and scalable operations. Hydrogen refuelling stations (HRS), particularly in urban, port, or depot environments, face challenges related to storage footprint, boil-off management, and permitting. Immaterial's cryogenic *m*-MOF tanks offer a compact, low-pressure alternative to traditional high-pressure or liquefied hydrogen storage, addressing these critical barriers.

*m*-MOF tanks can act as intermediate buffers between electrolyzers and dispensers, reducing pressure drops, improving thermal stability, and cutting boil-off losses during idle or peak refuelling periods. Their low-pressure operation (<50 bar) enhances safety and simplifies permitting, while requiring less insulation and enabling more modular station design. This is particularly valuable in space-constrained or off-grid depots. As modular terminal storage, these tanks improve refuelling throughput and reduce site-level CAPEX.

By 2030, over 5,000 HRS are expected to be operational globally, led by growth in Europe, Japan, Korea, and California. Companies such as Chart Industries, Rhzyme2, Enagás, and Shell are developing large-scale LH<sub>2</sub> terminals and decentralised refuelling infrastructure, applications where *m*-MOF tanks can reduce energy consumption, enhance operational responsiveness, and enable safer, more flexible system integration.

### 8.3. Static Hydrogen Storage: Enabling Decarbonisation Beyond Mobility

While mobility offers a compelling early application for Immaterial's cryogenic *m*-MOF tanks, a broader and more enduring opportunity may lie in static hydrogen storage across industrial, grid, and decentralised use cases. Many of these sectors are constrained by the limitations of high-pressure or liquefied hydrogen systems, particularly in safety, footprint, and permitting. The modular, low-pressure, and high-density design of *m*-MOF tanks offering higher volumetric capacity makes them suitable for retrofitting brownfield sites, buffering intermittent electrolyser output, and scaling hydrogen adoption in constrained environments.

These applications span intermittent industrial buffering, grid balancing, bulk transport, and off-grid energy access. They support the growing hydrogen economy in geographies like the UK, EU, and North America regions investing heavily in electrolyser deployment, clean industrial feedstocks, and regional hydrogen hubs. This section outlines how *m*-MOF storage technology addresses the evolving needs of these use cases.

#### 8.3.1 Intermittent Industrial Storage

Electrolyser-driven hydrogen production is inherently variable when powered by renewable sources such as solar and wind. Industrial users ranging from steelmakers to refineries require a steady hydrogen supply that can be decoupled from these fluctuations. Immaterial's cryogenic *m*-MOF tanks offer a modular, low-pressure buffer that can safely store surplus hydrogen during high-output periods and release it steadily during low-output phases. With higher volumetric capacity at <50 bar, the system offers high-density storage while reducing infrastructure complexity, safety risks, and space requirements critical for brownfield integration.

Target geographies include the UK, Germany, Sweden, and North America regions investing in green industrial clusters, often without dense hydrogen pipeline networks. Projects like British Steel and BP's H2Teesside to deploy hydrogen infrastructure, Thyssenkrupp in Duisburg, and SSAB in Oxelösund and Luleå highlight the need for decentralised, compact hydrogen storage solutions to stabilise intermittent supply. As electrolysis scales, *m*-MOF tanks provide a practical route to ensure reliable feedstock for continuous industrial processes.

### **8.3.2 Long-Duration Energy Storage (LDES) and Backup Power**

As renewable energy generation penetration increases, the need for flexible, dispatchable energy grows particularly over multi-day or weekly timescales where batteries become less viable. Hydrogen, as a chemical energy carrier, is uniquely positioned to fulfil this role. Immaterial's *m*-MOF tanks offer a compact, low-pressure storage solution that integrates with PEM and SOFC fuel cells, supporting both grid-level LDES and backup power systems. Their modularity and safety profile make them particularly suited for sensitive sites such as hospitals, data centres, and remote substations.

The global LDES market is projected to reach £39–62 billion by 2030, with hydrogen demand forecast at 2 Mt/year in the EU, 0.5 Mt/year in the UK, and 4 Mt/year in North America. Key players include Bloom Energy (SOFC), Microsoft and Google (data centre backup), and NHS Trusts replacing diesel gensets with cleaner alternatives. *m*-MOF tanks reduce the permitting and CAPEX barriers that have historically limited hydrogen's role in this space opening the door to scalable, decentralised long-duration storage.

### **8.3.3 Bulk Hydrogen Transport (up to 5,000 km)**

In regions lacking extensive pipeline networks, hydrogen must be transported via road, rail, or intermodal containers especially between decentralised electrolyser sites and industrial or refuelling hubs. Immaterial's *m*-MOF tanks are optimised for this use case, offering 1.5–2x the volumetric hydrogen density of Type IV tanks while operating at under 40 bar. This enables denser and safer transport, reduces swap frequency, and simplifies regulatory compliance compared to high-pressure or liquefied options.

The technology aligns with strategic corridors such as the Netherlands-Germany industrial belt and Iberia's emerging hydrogen export routes to northern Europe. Companies like Nikola, DB Schenker, and Linde are actively piloting hydrogen logistics, where *m*-MOF tanks can improve payload efficiency and reduce operational complexity. As REPowerEU and the Hydrogen Backbone strategies accelerate cross-border hydrogen trade, cryogenic MOF-based storage offers a uniquely efficient and scalable solution for medium-distance hydrogen transport.

### **8.3.4 Remote and Off-Grid Energy Access**

Remote communities, island grids, and off-grid industrial operations often face high energy costs and diesel dependency. Hydrogen, produced from renewables and stored locally, can offer cleaner and more resilient alternatives. Immaterial's cryogenic *m*-MOF tanks are particularly well suited for these settings, compact, modular, and easy to transport with minimal operational complexity. They avoid boil-off issues associated with liquefied hydrogen and eliminate the safety and permitting challenges tied to high-pressure systems.

Initiatives like the Scottish Islands Energy Hub and Croatia's solar-powered hydrogen pilots demonstrate early demand for such decentralised storage. Globally, over one billion people live in energy-insecure regions, and hydrogen-based mini-grids are increasingly being funded through national and multilateral programmes. Immaterial's tanks provide the enabling storage infrastructure to make these off-grid hydrogen ecosystems viable, reducing cost, improving autonomy, and accelerating clean energy access.

#### **8.4. Outcome(s) of Discussions with Prospective End Users**

Discussions with prospective end users during HySupply advisory board meetings and follow-up engagements highlighted strong synergies between Immaterial's cryogenic *m*-MOF tanks and the evolving needs across mobility and decentralised storage applications. Several stakeholders emphasised the relevance of the technology in off-grid and island-based hydrogen-powered EV charging infrastructure, validating its suitability in stationary, decentralised contexts where low-pressure, high-density storage can buffer intermittent renewables. Technical follow-ups were requested on compatibility with small-scale electrolyzers and performance benchmarking against alternative storage systems, with some parties indicating interest in facilitating commercial introductions within the wider e-mobility ecosystem.

In the rail sector, insights from OEMs helped define key operating parameters such as onboard hydrogen storage capacity (200–300 kg per train), refuelling intervals (1–2 days), and refill time targets ( $\leq 30$  minutes). Long system lifetimes (30 years for trains, up to 10 years for fuel cells), modularity, and durability were identified as essential. Immaterial's demonstrator performance and techno-economic assessments were welcomed as part of ongoing alignment with rail integration needs.

Heavy-duty transport stakeholders shared storage targets of 80 kg H<sub>2</sub> per truck at 700 bar, with vehicle lifetime expectations of up to 1.2 million km. Refuelling time (10–15 minutes), system weight, and volume constraints were considered critical to commercial viability. Immaterial's development progress, including a 200-litre demonstrator tank and 25 tpa *m*-MOF manufacturing scale-up has attracted interest, especially with higher volumetric & working capacity performance targets. End users encouraged referencing public benchmarks (e.g., NOW, DOE) and highlighted heat transfer and system integration improvements as key enablers for future adoption.

### **9. Conclusions and Next Steps**

The project has successfully demonstrated the feasibility of MOF-based hydrogen storage across progressively scaled systems, from a 2 L test rig, through the 20 L prototype, and culminating in the full-scale 200L demonstrator tank. A major milestone was achieved with the integration of the demonstrator system into a hydrogen bus and the completion of a successful driven test, thereby validating the technology under real operating conditions.

While all performance targets were not fully achieved, the project met its primary objective of proving the technical viability of *m*-MOF for hydrogen delivery and identifying the key factors that

govern system-level performance. The demonstrator achieved 3.68 kg of stored hydrogen, lower than the projected 4.9 kg capacity per tank, with the shortfall attributable to system cooling limitations. These outcomes provide essential learning to inform future design improvements, and there are routes by which these may be overcome.

The supporting work packages also delivered valuable results. Material production and characterisation highlighted the importance of storage stability and activation protocols, while the development of 1D and 2D CFD models established robust predictive tools for system design and optimisation. Importantly, the techno-economic assessment indicated that MOF technology shows potential feasibility for intermediate hydrogen storage applications.

Overall, the project achieved its overarching goal of demonstrating the technical feasibility of MOF-based hydrogen storage, both at laboratory and demonstrator scales, and provided the experimental and analytical evidence necessary to support further development towards commercial readiness.

## Next Steps

Building on the achievements of this project, the next phase of work should focus on several key areas. First, a dedicated study into the application of MOF technology for intermediate hydrogen storage is recommended, as the techno-economic assessment has indicated promising feasibility in this area. This study should explore both technical performance and cost-effectiveness in real-world operating contexts.

Second, refinement of the demonstrator system design is necessary to address the limitations observed during testing. Particular attention should be given to improving consistent cooling performance, and optimising packing efficiency to increase overall hydrogen storage capacity.

Finally, the techno-economic analysis should be scaled and updated to reflect the revised system performance and the insights gained from the demonstrator. This will provide a more robust understanding of the commercial potential of MOF-based hydrogen storage and define the conditions under which the technology can be competitive with established alternatives.

## 10. References

[1] J. Am. Chem. Soc. 2022, 144, 30, 13729–13739

[2] Plant Design and Economics for Chemical Engineers (Peters & Timmerhaus)

[3] <https://www.iea.org/reports/global-hydrogen-review-2021/executive-summary>

[4] D.M. Ruthven (1985). *Principles of adsorption & adsorption processes*, John Wiley & Sons, 1984, xxiv + 433 pp. *AIChE Journal*, 31(3), 523–524. <https://doi.org/10.1002/aic.690310335>

[5] Erofeev. Y, (Dec 2024), More than 20 percent of hydrogen projects in Europe have been frozen or canceled, Medium, <https://medium.com/@erofeev.yury/more-than-20-percent-of-hydrogen-projects-in-europe-have-been-frozen-or-canceled-5171b52443c3>, Accessed on: 07.10.25.

[6] <https://www.ipcc.ch/data/>



