



Department
for Transport

Specification for the Reinstatement of Openings in Highways

Fourth edition



May 2020

The Department for Transport has actively considered the needs of blind and partially sighted people in accessing this document. The text will be made available in full on the Department's website. The text may be freely downloaded and translated by individuals or organisations for conversion into other accessible formats. If you have other needs in this regard, please contact the Department.

Department for Transport
Great Minster House
33 Horseferry Road
London SW1P 4DR
Telephone 0300 330 3000
Website www.gov.uk/dft
General enquiries: <https://forms.dft.gov.uk>



© Crown copyright 2020

Copyright in the typographical arrangement rests with the Crown.

You may re-use this information (not including logos or third-party material) free of charge in any format or medium, under the terms of the Open Government Licence. To view this licence, visit <http://www.nationalarchives.gov.uk/doc/open-government-licence/version/3/> or write to the Information Policy Team, The National Archives, Kew, London TW9 4DU, or e-mail: psi@nationalarchives.gsi.gov.uk

Where we have identified any third-party copyright information you will need to obtain permission from the copyright holders concerned.

Contents

Foreword	10
Definitions	11
S0 Preamble	16
S0.1 General	16
S0.2 Outline of the specification	16
S0.3 Outline of the appendices	16
S0.4 Outline of the Notes for Guidance	17
S0.5 Using the specification and appendices	17
S1 Operational principles	19
S1.1 General	19
S1.2 Guarantee period	19
S1.3 Road categories	20
S1.4 Footway, footpath and cycle track categories	20
S1.5 Excavation and trench categories	21
S1.6 Alternative options	21
S1.7 Immediate works	22
S1.8 Apparatus in roads, footways, footpaths and cycle tracks	22
S1.9 Geosynthetic materials, geotextiles and reinforcement grids	23
S1.10 Trees	23
S1.11 Conciliation and arbitration	23
S2 Performance requirements	24
S2.1 General	24
S2.2 Surface profile	26
S2.3 Fixed features	28
S2.4 Surface regularity	30
S2.5 Structural integrity	31
S2.6 Skid resistance	33
S2.7 Sampling and testing	38
S2.8 Works in deteriorated or distressed areas	38
S3 Excavation	40

S3.1	Breaking the surface	40
S3.2	Excavation	40
S3.3	Excavated material	41
S3.4	Side support	41
S3.5	Drainage	41
S3.6	Shallow or aborted excavations	41
S3.7	Mole ploughing and trenchless pipelaying	42
S4	Surround to apparatus	43
S4.1	General	43
S5	Backfill	44
S5.1	Backfill material classification	44
S5.2	Alternative reinstatement materials (ARMs)	45
S5.3	Additional requirements	45
S6	Flexible and composite roads	47
S6.1	Reinstatement methods	47
S6.2	Sub-base reinstatement	48
S6.3	Base reinstatement	48
S6.4	Surface reinstatement	50
S6.5	Small openings, narrow trenches and access chamber covers	54
S6.6	Micro trenching	56
S6.7	Large diameter cores	59
S6.8	Base and edge preparation	63
S6.9	Tolerances	69
S7	Rigid and modular roads	70
S7.1	Reinstatement methods	70
S7.2	Sub-base reinstatement	71
S7.3	Concrete road slab reinstatement	71
S7.4	Large diameter cores	73
S7.5	Edge support and preparation	73
S7.6	Reinforcement	76
S7.7	Overlays	78
S7.8	Modular roads	78
S7.9	Tolerances	79
S8	Footways, footpaths and cycle tracks	80
S8.1	Reinstatement methods	80
S8.2	Sub-base reinstatement	81

S8.3	Surface reinstatement	82
S8.4	Micro trenching	84
S8.5	Large diameter cores	84
S8.6	Edge requirements	84
S8.7	Vehicular trafficking	86
S8.8	Tolerances	86
S9	Verges and unmade ground	87
S9.1	General	87
S9.2	Adjacent road structures	87
S9.3	Cultivated areas	88
S9.4	Grassed areas	88
S9.5	Verges, ditches and drainage courses	88
S10	Compaction requirements	89
S10.1	Introduction	89
S10.2	Compaction of materials	89
S10.3	Equipment operation and restrictions	91
S11	Ancillary activities	94
S11.1	Traffic signs, road markings, studs and verge markers	94
S11.2	Street furniture and special features	96
S11.3	Traffic sensors, etc.	96
S11.4	Water-related matters	96
S11.5	Ironwork in roads, footways, footpaths and cycle tracks	97
S11.6	Test holes	100
S12	Remedial works	102
S12.1	General	102
S12.2	Safety requirements	102
S12.3	Repair of cracking	102
S12.4	Repair of settlement beyond reinstatement limits	104
S12.5	Repair of other significant defects	105
Appendix A1	Backfill materials	106
A1.1	Class A – Graded granular materials	106
A1.2	Class B – Granular materials	106
A1.3	Class C – Cohesive/granular materials	106
A1.4	Class D – Cohesive materials	106
A1.5	Class E – Unacceptable materials	107
A1.6	Field identification tests	107

Appendix A2 Key to materials	111
A2.0 Introduction	111
A2.1 Hot rolled asphalt (HRA) mixtures	111
A2.2 Stone mastic asphalt (SMA) mixtures	114
A2.3 Asphalt concrete mixtures	115
A2.4 Cold-lay surfacing materials	117
A2.5 Flowable materials	117
A2.6 Reinstatement materials for micro trenches	120
A2.7 Structural layer thickness tolerances	121
A2.8 Compacted lift thickness	122
A2.9 Bituminous laying temperatures	124
A2.10 Identification of structural layers	125
A2.11 Key to materials	130
A2.12 Key to reinstatement methods	132
A2.13 Summarised selection process for hot lay flexible materials	134
Appendix A3 Flexible roads	138
A3.1 Flexible roads type 0	138
A3.2 Flexible roads type 1	139
A3.3 Flexible roads type 2	140
A3.4 Flexible roads type 3	141
A3.5 Flexible roads type 4	142
A3.6 Sub-base construction for flexible roads	143
Appendix A4 Composite roads	144
A4.1 Composite roads type 0	144
A4.2 Composite roads type 1	145
A4.3 Composite roads type 2	146
A4.4 Composite roads types 3 and 4	147
A4.5 Sub-base construction for composite roads – types 0, 1 and 2	148
A4.6 Sub-base construction for composite roads types 3 and 4	149
Appendix A5 Rigid roads	150
A5.1 Rigid roads type 0	150
A5.2 Rigid roads type 1	151
A5.3 Rigid roads types 2, 3 and 4	152
Appendix A6 Modular roads	153
A6.1 Modular roads (bituminous base) types 3 and 4	153
A6.2 Modular roads (composite base) types 3 and 4	154

A6.3 Modular roads (granular base) types 3 and 4	155
Appendix A7 Footways, footpaths and cycle tracks	156
A7.1 Flexible footways, footpaths and cycle tracks	156
A7.2 Composite footways, footpaths and cycle tracks	157
A7.3 Rigid footways, footpaths and cycle tracks	158
A7.4 Modular footways, footpaths and cycle tracks	159
Appendix A8 Compaction requirements	160
A8.1 Granular, cohesive and cement bound materials	160
A8.2 Chalk materials	162
A8.3 Bituminous mixtures	163
Appendix A9 Alternative reinstatement materials and technologies	164
A9.1 Introduction	164
A9.2 General requirements for ARMs and ATs	165
A9.3 Structural materials for reinstatements (SMRs)	166
A9.4 Treated materials for fills (TMFs)	168
A9.5 Outline scheme for approval trials	170
Appendix A10 Additional standard materials	175
A10.0 General	175
A10.1 Modified Type 1F Unbound Mixture (0/20)	175
A10.2 Hydraulically bound materials (HBMs)	177
Appendix A11 Product Equivalence	185
Appendix A12 Reinstatement of modular surface layers	186
A12.1 Interim reinstatement	186
A12.2 Permanent reinstatement	186
A12.3 Provision of replacement modules	189
A12.4 Joint inspections and recovery of costs	189
NG1 Operational principles	192
NG1.1 General	192
NG1.2 Guarantee period	192
NG1.3 Road categories	193
NG1.5 Excavation and trench categories	195
NG1.6 Alternative options	196
NG1.7 Immediate works	198
NG1.8 Apparatus within the road structure	198
NG1.9 Geosynthetic materials, geotextiles and reinforcement grids	198
NG1.10 Trees	199

NG2	Performance requirements	201
NG2.2	Surface profile	201
NG2.3	Fixed features	202
NG2.4	Surface regularity	203
NG2.5	Structural integrity	203
NG2.6	Skid resistance	203
NG2.8	Works in deteriorated or distressed areas	204
NG3	Excavation	207
NG3.1	Breaking the surface	207
NG3.2	Excavation	207
NG3.4	Side support	207
NG4	Surround to apparatus	208
NG4.1	General	208
NG5	Backfill	209
NG5.1	Backfill material classification	209
NG5.3	Additional requirements	209
NG6	Flexible and composite roads	211
NG6.2	Sub-base reinstatement	211
NG6.3	Base reinstatement	211
NG6.4	Surface reinstatement	212
NG6.5	Reinstatement of small openings and narrow trenches	214
NG6.6	Micro trenches	215
NG6.7	Large diameter cores	217
NG6.8	Base and edge preparation	220
NG7	Rigid and modular roads	225
NG7.1	Reinstatement methods	225
NG7.3	Concrete road slab reinstatement	225
NG7.5	Edge support and preparation	226
NG7.6	Reinforcement	226
NG7.8	Modular roads	226
NG8	Footways, footpaths and cycle tracks	227
NG8.2	Sub-base and binder course reinstatement	227
NG8.3	Surface reinstatement	227
NG9	Verges and unmade ground	229
NG9.1	General	229
NG10	Compaction requirements	230

NG10.1	Introduction	230
NG10.2	Compaction of materials	230
NG10.3	Equipment operation and restrictions	232
NG11	Ancillary activities	236
NG11.1	Traffic signs, road markings, studs and verge markers	236
NG11.2	Street furniture and special features	236
NG11.3	Traffic sensors etc.	236
NG11.4	Water-related matters	236
NG11.5	Ironwork and apparatus	237
NG12	Remedial works	238
NG12.1	General	238
NGA2	Key to materials	239
NGA2.0	Introduction	239
NGA2.1	Hot rolled asphalt (HRA) mixtures	239
NGA2.2	Stone mastic asphalt (SMA) mixtures	240
NGA2.3	Asphalt concrete mixtures	242
NGA2.4	Cold-lay surfacing materials	242
NGA2.7	Structural layer thickness tolerances	243
NGA2.9	Bituminous laying temperatures	243
NGA2.13	Selection process for hot lay flexible materials	245
NGA8	Compaction requirements	246
NGA8.3	Bituminous mixtures	246
NGA9	Alternative reinstatement materials and technologies	247
NGA9.1	Introduction	247
NGA9.2	General requirements for ARMs and ATs	248
NGA9.4	Treated materials for fills (TMFs)	249
NGA9.5	Outline scheme for the approval trials	249
NGA10	Additional standard materials	254
NGA10.0	General	254
NGA10.2	Hydraulically bound materials (HBMs)	254
NGA12	Reinstatement of modular surfaces	256
NGA12.1	General	256
NGA12.2	Examples of cement or concrete infills	256
NGA12.3	Examples of reinstatement of modular patterns	256

Foreword

Our road network and the way we operate it has a direct impact on everyone's lives. Whilst the primary purpose of our highways is to facilitate safe and convenient travel for all, they also serve an important function in accommodating the essential services on which we all rely - water, gas, electricity and telecommunications.

To make sure these services operate reliably, utility companies must, from time to time, maintain, repair and install apparatus under our roads. Given the impact these works can have on the travelling public, it is important that they are completed as quickly and efficiently as possible. At the same time, utilities have to reinstate the roads to certain standards to ensure they do not shorten their life or create uneven running surfaces.

This statutory code of practice, published under Section 71 of the New Roads and Street Works Act 1991, is key to achieving these aims. The previous edition was last updated in April 2010 and much has changed since then. Apart from issues that have arisen over its interpretation, many innovations in reinstatement techniques and materials have been introduced that were not covered.

The 4th edition is intended to address these issues and bring the document up to date. It supports innovation and allows new techniques and materials to be used. It should help reduce the time taken to carry out street works and make it easier for utilities to get their reinstatements right first time, and so avoid return site visits. It should also improve the quality and durability of reinstatements, and help to protect this vital national asset.

We would especially like to thank members of the SROH working party (a Highway Authorities and Utilities Committee working group) for the considerable contribution they made in developing this edition. Their advice was invaluable in helping us to identify the issues to be addressed and in suggesting ways to resolve them.

We would also like to thank the wider group of experts from across this sector for their input, advice and contributions to the new SROH, and AECOM/Arup who led on the update of this document and delivered a technical specification that will support and deliver our aims for high quality and well-managed street works.

This version of the Code replaces the 3rd edition in England and comes into force as statutory guidance on 10th May 2021. It can be used by agreement with local authorities until then, especially if it helps during the coronavirus pandemic.

Definitions

AAV	Aggregate Abrasion Value - the standard measure of an aggregate's resistance to abrasion.
Authority	The authority as defined in the Act.
Bond coat	Proprietary materials certified by a Product Acceptance Scheme, generally formulated to provide cohesion between bituminous layers.
CBGM base	Cement bound granular mixture – a mixture of controlled graded aggregate using cement that sets and hardens by hydraulic reaction. This is a specific type of relatively strong hydraulically bound material (HBM) typically used for base layers in composite roads.
CBR	California bearing ratio - a penetration test for the mechanical strength of soils and granular materials.
Composite footway, footpath or cycle track construction	A pavement comprising lean mix concrete or other hydraulically bound material (including cement bound granular mixtures) overlaid with a bituminous surface course or a bituminous surface and binder course.
Composite road construction	A pavement comprising concrete, lean mix concrete, CBGM base or some other hydraulically bound granular material with a bituminous overlay of 100 mm or more. Where the bituminous overlay is less than 100 mm or there is no bituminous overlay, the pavement is considered rigid.
Cut-back	See 'stepped joint'.
Cycle track	A way constituting or comprised in a highway, being a way over which the public have a right of way on pedal cycles only, with or without a right of way on foot.

Deep opening	Any opening, excavation, core or trench where the depth of cover over the apparatus is greater than 1.5 m but not including openings with a depth of cover intermittently greater than 1.5 m over lengths of less than 5 m.
DMRB	Design Manual for Roads and Bridges.
Emergency works	Works required to prevent the occurrence of circumstances likely to cause danger to persons or property. See S52 of the Act for the formal definition.
FCR	Foamed Concrete for Reinstatements.
Flexible construction	A structure where the base comprises a bituminous or granular material, or a combination thereof.
Footpath	A way over which the public has a right of way on foot only, not being a footway.
Footway	A way comprised in a highway, which also comprises a carriageway, being a way over which the public has a right of way on foot only.
Geosynthetic materials	A generic term describing a product at least one of whose materials components is made from a synthetic or natural polymer in the form of a sheet or a 3D structure and used in contact with soil or other materials in geotechnical and civil engineering applications.
HBM	Hydraulically bound material – material comprising a mixture of soil and/or graded granular material with hydraulic binder and water that sets and hardens by hydraulic reaction.
Immediate reinstatement	Works comprising the orderly replacement of excavated material, reasonably compacted to finished surface level, usually with a cold-lay surfacing. This technique is used when it becomes necessary to temporarily reinstate an excavation to permit immediate trafficking.
Interim reinstatement	The orderly placement and proper compaction of reinstatement layers to finished surface level, including any temporary materials.
Intervention	Repair to a compliant condition of a reinstatement that does not comply with the performance requirements of this Code.

LA	Los Angeles abrasion value – a measure of an aggregate's resistance to abrasion.
Large diameter core	A core over 150 mm in diameter.
Major works	Standard works that have been identified specifically in the undertaker's annual operating programme or which, if not specifically identified in that programme, are normally planned at least 6 months in advance of works commencing.
MCHW	Manual of Contract Documents for Highway Works.
Micro trench	An opening up to 60 mm wide and over 1 m long.
Modular construction	A structure where the surface comprises setts, concrete blocks, brick pavers or paving slabs etc. laid on an appropriate sub-construction.
msa	Million standard axles – based on the expected traffic to be carried over 20 years. See S1.3.
Narrow trench	An opening over 60 mm and up to 300 mm wide and over 1 m long.
NRSWA	See "The Act".
Other openings	Any opening, excavation or core that is not a micro trench, a narrow trench, a large diameter core, a small opening or a deep opening.
Pen	The penetration grade of a bituminous binder.
Permanent reinstatement	The orderly placement and proper compaction of reinstatement layers up to and including the finished surface.
PMMA	Polymer modified mastic asphalt to BS EN 13108-6.
Preferred	The favoured choice between permitted options.
Product Acceptance Scheme	Product Acceptance Scheme in accordance with 100 Series of the MCHW, Clauses 104.15 and 104.16 (such as British Board of Agrément certificates).

PSV	Polished Stone Value.
Restricted area	Small openings, openings less than 200 mm wide or other areas where conventional compaction equipment cannot be used effectively.
Rigid construction	A pavement quality concrete surface slab (that may be reinforced) which also performs as the base or a concrete base with less than 100 mm bituminous overlay. Where the bituminous overlay is 100 mm or more the pavement is considered to be composite.
Road & footway structure	The surface course, binder course, base and sub-base.
Small features	Frames and surface boxes smaller than 600 mm x 600 mm.
Small openings	An excavation with a reinstatement surface area, excluding the apparatus surface area, up to 2 m ² in road types 0, 1 and 2 and up to 4 m ² in road types 3 and 4 and in footways, footpaths and cycle tracks, that is not a large diameter core, a micro trench or a narrow trench.
SRV	Skid Resistance Value – a measure of the frictional properties of a surface using a pendulum test device.
Stepped joint	A step where the reinstated binder and/or surface courses are made wider than the reinstatement below to provide higher resistance to water ingress.
Street	The whole or any part of the following, irrespective of whether it is a thoroughfare: <ul style="list-style-type: none"> a) any highway, road, lane, footway, alley or passage, b) any square or court, and c) any land laid out as a way whether it is for the time being formed as a way or not; and for the avoidance of doubt includes land on the verge of a street or between two carriageways. Where a street passes over a bridge or through a tunnel, references to the street include that bridge or tunnel (NRSWA Section 48 etc.).
Street manager	As referred to in the Act, Section 49(4).

Surface treatment	A thin protective layer (e.g. surface dressing) applied to the surface to restore skid resistance and/or to seal it. This does not include high amenity or high duty surfaces, or surfaces with an aesthetic requirement.
The Act	The New Roads and Street Works Act 1991 (NRSWA).
Trim-line	The cut face that defines the outer edge of an excavation at the surface.
Trimback	The area between the trim-line and a fixed feature and the edge of an excavation.
UKAS	United Kingdom Accreditation Service.
Undertaker	A person with a statutory right to execute street works or the holder of a street works licence.
Verge	The area of the highway outside the carriageway (and footway if present). A verge may be slightly raised but is exclusive of embankment or cutting slopes and is generally grassed.
Wheel tracking	A test to determine the resistance to deformation (rutting) of, primarily, surface courses.

S0 Preamble

S0.1 General

This Code applies to all undertakers reinstating the highway. It prescribes materials that may be used, the expected standards of workmanship and performance standards to be complied with at both interim and permanent reinstatement stages, and for the duration of the relevant guarantee period, as defined in S1.2.

S0.2 Outline of the specification

The 'S' sections are the Code's specification and they are ordered to reflect what practitioners need to know before commencing works, what will be required to complete the works, and the obligations upon undertakers once works are completed.

S1 and S2 respectively set out the general parameters associated with reinstatements and the expected performance requirements.

S3, S4 and S5 follow the normal sequence of operations for undertakers, namely excavation, placing surround material to apparatus and backfilling.

S6 and S7 set out the detailed requirements and permissible reinstatement methods for bound materials in carriageways. Limitations on the use of preferred and permissible materials (more fully detailed in appendices A1, A2, A9 and A10) are described. Similarly, S8 and S9 set out the requirements for reinstatements in footways and verges.

S10 sets out the fundamental requirements for compaction of reinstatement materials, and includes guidance on the degree of compaction necessary to comply with the Code and its end performance requirements.

S11 and S12 respectively cover ancillary activities that might be encountered during street works and the prescribed remedial measures in the event that the reinstatement is defective or causes settlement beyond the limits of the reinstatement.

S0.3 Outline of the appendices

The 'A' section contains the appendices. They complement the specification section, setting out technical details and the design of different reinstatements. They reflect the various categories of surfaces normally encountered in carriageways, footways and verges.

S0.4 Outline of the Notes for Guidance

The Notes for Guidance complement the Code and some of the appendices. However, whilst Notes for Guidance contain information thought to be useful to support practitioners, they are not enforceable.

S0.5 Using the specification and appendices

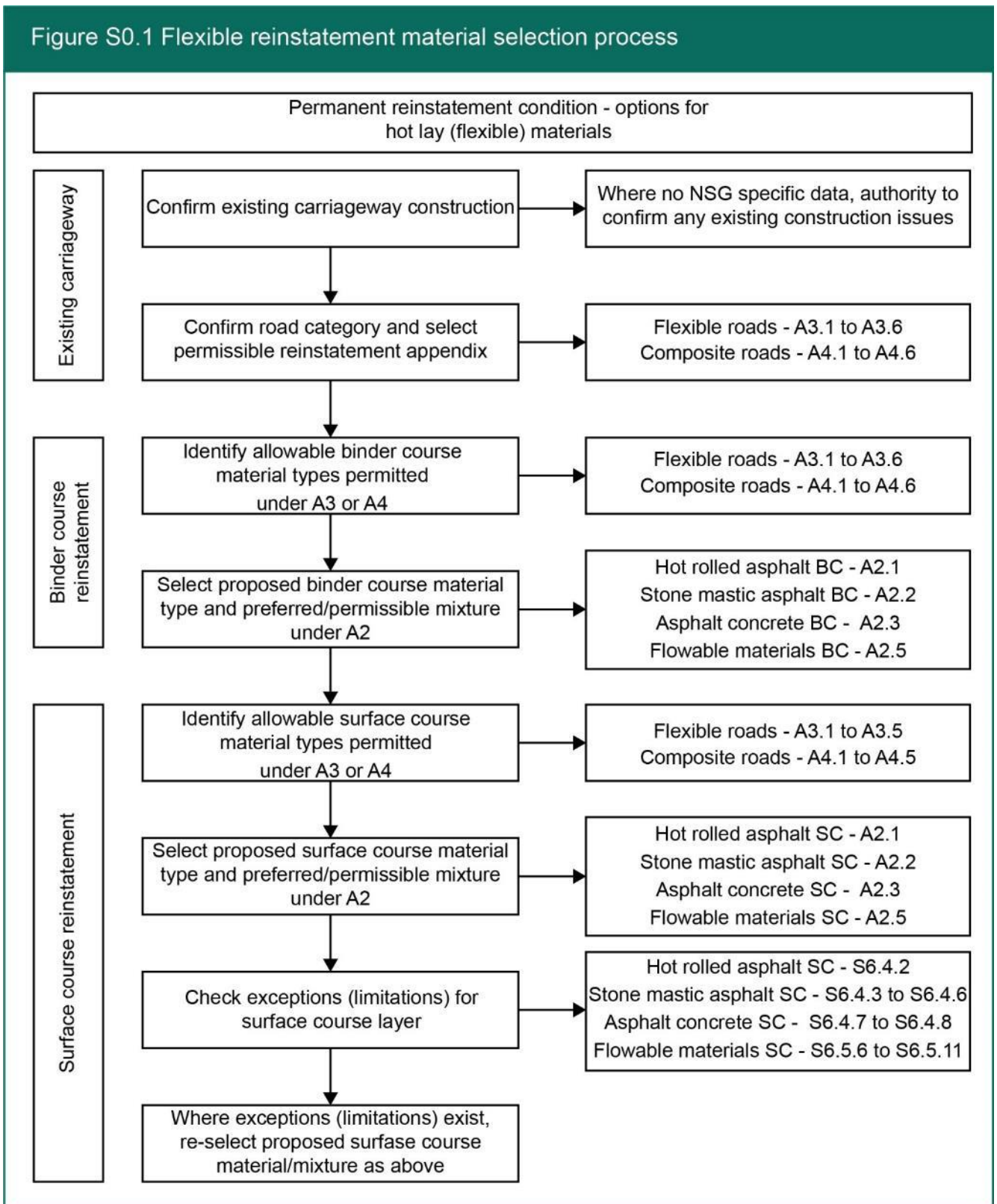
There are references to reinstatement materials in various parts of the specification and the appendices. These include:

- 1) the overall class of materials, such as hot rolled asphalts (HRA), stone mastic asphalts (SMA), asphalt concretes (AC) and traditional concretes used in some roads;
- 2) different types of mixture within each class of material. These tend to relate to the relative position of the mixture within the overall reinstatement (e.g. AC surface course, AC binder course) and reflect the design function of the layer;
- 3) different preferred (and permissible) mixtures for different layers;
- 4) different thicknesses of mixture layers;
- 5) specific requirements and limitations for surface courses.

Each of the above has been assigned to different parts of the Code and it is essential that they are taken into account when selecting the reinstatement design for a particular surface category.

The reinstatement of flexible roads (and footways) is particularly complex at the reinstatement design selection stage. To assist practitioners, Figure S0.1 sets out the intended materials selection process for flexible (and composite) carriageways.

Figure S0.1 Flexible reinstatement material selection process



S1 Operational principles

S1.1 General

- S1.1.1 This Code incorporates terminology introduced under the BS EN series of standards for asphalt, concrete, unbound and hydraulically bound mixtures.
- S1.1.2 An undertaker executing street works must comply with this Code and guarantee the performance of the reinstatement for the relevant guarantee period.
- S1.1.3 Reinstatement must be carried out using a permitted method incorporating the highest degree of interim or permanent reinstatement, as considered appropriate for the circumstances in the opinion of the undertaker.
- S1.1.4 If, at any time during a guarantee period, the reinstatement fails any relevant requirements in S2 of this Code, then the undertaker must carry out remedial action to restore it to a compliant condition. An interim reinstatement must normally be made permanent within six months.
- S1.1.5 When it is discovered at any time that the reinstatement does not conform to a requirement in this Code, other than those detailed in S2, then remedial work must be assessed in accordance with S12. In this case the guarantee period will not commence until the remedial works have occurred.
- S1.1.6 The requirements of this Code apply to streets that are maintainable at public expense. In the case of all other streets, only the parts of the Code relating to “surround to apparatus” and “backfill” apply. Surfacing layers should be reinstated to match existing construction as far as is reasonably practicable. The exception to this is where options are provided within this Code for selection of asphalt surfaces, including details of where they may be used. In all cases, reinstatement must be to the reasonable satisfaction of the street manager. Specific provisions are given for high amenity areas (S1.4.2) in this Code.

S1.2 Guarantee period

- S1.2.1 The undertaker must ensure that an interim reinstatement conforms to the prescribed standards until the permanent reinstatement is completed, and that the permanent reinstatement conforms to the prescribed standards throughout the guarantee period.
- S1.2.2 The guarantee period begins on completion of the permanent reinstatement and runs for two years in general, or three years in the case of deep openings. Note that it is the completion of the permanent

reinstatement, rather than the date of informing the authority that the reinstatement is completed, that triggers the start of the guarantee period.

S1.3 Road categories

S1.3.1 There are five categories of road, each with a limiting capacity expressed in millions of standard axles (msa) as shown in Table S1.1.

Road category	Traffic capacity
Type 0	Roads carrying over 30 to 125 msa
Type 1	Roads carrying over 10 to 30 msa
Type 2	Roads carrying over 2.5 to 10 msa
Type 3	Roads carrying over 0.5 to 2.5 msa
Type 4	Roads carrying up to 0.5 msa

- S1.3.2 Roads carrying more than 125 msa are not covered in this Code. Reinstatement designs for such roads must be agreed between the undertaker and the authority.
- S1.3.3 The road categories in Table S1.1 are based on the expected traffic to be carried over the next 20 years. Each authority must categorise its road network on this basis and the undertaker must use the most current information available from the authority.
- S1.3.4 Valid traffic flows must be assessed by accurately monitoring commercial vehicles excluding cars and light vans. Traffic growth rates must be determined from the average of at least three separate assessments carried out over at least three years. Where traffic growth rates are expected to increase significantly because of changing traffic patterns, only predictions generated from a recognised planning process may be used. A zero-traffic growth rate must be assumed until accurate information is available.
- S1.3.5 The reinstatement must be designed using materials specified in A1, A2, A9 and A10. The overall layer thickness must be as specified in A3 to A7 for the various categories of road, footway, footpath, cycle track, verge or unmade ground, and must be compacted to the requirements of S10 and A8.

S1.4 Footway, footpath and cycle track categories

Footways, footpaths and cycle tracks are categorised as follows:

- S1.4.1 High duty – routes designated as principal routes and used by an exceptionally large number of pedestrians and/or cyclists.
- S1.4.2 High amenity – routes surfaced with one of the following surfaces, and constructed and maintained to a high standard:
- 1) Surfaces chosen specifically for decorative purposes, with special colours, textures or surface finishes; or
 - 2) Flexible surfaces with a particular texture or distinctive coloured finish. Such surfaces will usually be situated in conservation, leisure or

ornamental areas, pedestrian precincts or where an authority has installed high quality paving.

S1.4.3 Other – surfaces that are neither high duty nor high amenity.

S1.4.4 Where an authority can demonstrate that a high duty or high amenity footway, footpath or cycle track has been constructed and maintained to a standard in excess of that prescribed in S2.2 to S2.5 (and registered accordingly) the reinstatement must meet the authority's standard of maintenance and their declared intervention criteria.

S1.5 Excavation and trench categories

Excavations and trenches are categorised as follows:

S1.5.1 Large diameter core – a core over 150 mm in diameter.

S1.5.2 Micro trench – an opening up to 60 mm wide and over 1 m long.

S1.5.3 Narrow trench – an opening over 60 mm and up to 300 mm wide and over 1 m long.

S1.5.4 Small openings – an excavation that is none of the above, with a reinstatement surface area, excluding the apparatus surface area, up to:

- 1) 2 m² in road types 0, 1 and 2; or
- 2) 4 m² in road types 3 and 4 and in footways, footpaths and cycle tracks.

S1.5.5 Other openings – any excavation or trench that is none of the above (S1.5.1 to S1.5.4).

S1.5.6 Deep opening – any of the above (S1.5.1 to S1.5.5) where the depth of cover over apparatus is greater than 1.5 m but not including openings with a depth of cover intermittently greater than 1.5 m over lengths of less than 5 m.

S1.6 Alternative options

S1.6.1 Subject to the provisions for alternative reinstatement materials (ARMs) and alternative technologies (ATs) in A9, an undertaker may adopt an alternative specification for materials and/or the installation process to take advantage of new or local materials and alternative compaction equipment, subject to the agreement of the authority. Agreement from the authority must not be unreasonably withheld (see A9). There can be no departure from the performance requirements during the guarantee period.

S1.6.2 Recycled or primary materials, or any combination thereof, are permitted by this Code provided they meet the performance requirements and any compositional requirements for the relevant material layer.

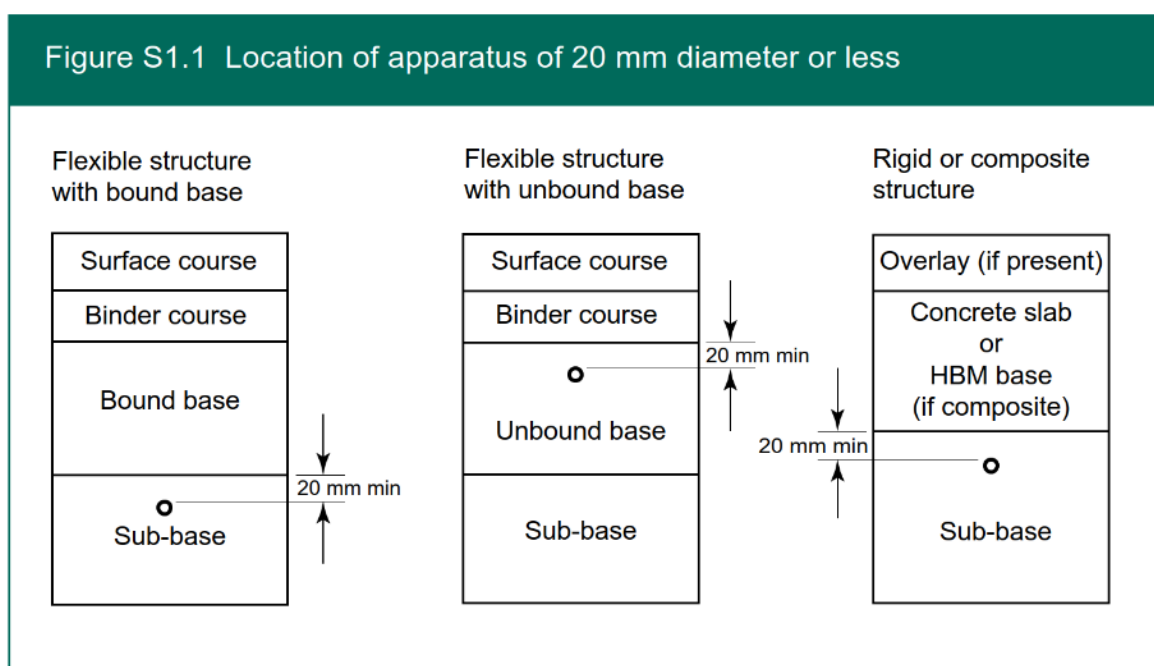
S1.6.3 Bound materials are permitted for use as surround to apparatus and at backfill and sub-base layers provided they meet the relevant performance requirements of this Code (see S4). This includes an upper limit on strength.

S1.7 Immediate works

- S1.7.1 There will be times when it becomes necessary to temporarily reinstate an excavation to permit immediate trafficking. In such circumstances, reinstatements may be completed using excavated or other materials compacted in 100 mm layers, with a minimum surfacing thickness of 40 mm of bituminous material.
- S1.7.2 All materials so placed that do not comply with the requirements of this Code must be re-excavated and reinstated to the appropriate interim or permanent standard as specified in S6, S7 or S8. This should be done as soon as practicable but, in any case, within 10 working days of completion of the immediate works or as agreed with the authority.

S1.8 Apparatus in roads, footways, footpaths and cycle tracks

- S1.8.1 Apparatus over 20 mm external diameter is not permitted within road, footway or cycle track structures unless special circumstances exist (for example shallow cover over culverted watercourses, utility apparatus etc). In these special circumstances the utility must consult the authority whose approval must not be unreasonably withheld.
- S1.8.2 Apparatus of 20 mm external diameter or less is not permitted above or within 20 mm of the following levels within a road structure (see Figure S1.1):
- 1) The base/binder course interface in a flexible structure.
 - 2) The underside of the base in a composite structure.
 - 3) The underside of the concrete slab in a rigid structure.
 - 4) The underside of the complete construction (formation layer) in a modular structure (refer to Figures A6.1 to A6.3).



- S1.8.3 Where other existing apparatus or surrounds occur within the road structure, the method of reinstatement must be determined by agreement.

S1.9 Geosynthetic materials, geotextiles and reinforcement grids

- S1.9.1 Where an authority knows of the existence of any of the above materials in areas likely to be affected by an undertaker's work, it should inform the undertaker before works start so that an appropriate reinstatement method can be agreed.

- S1.9.2 If the undertaker is not informed of the existence of any of the above materials before works start but encounters them during the works, the undertaker should inform the authority immediately so that an appropriate reinstatement method can be agreed. In these circumstances, the undertaker is not liable for the repair of any damage caused to geosynthetic materials, geotextiles or reinforcement grids before their existence was known.

S1.10 Trees

- S1.10.1 When working near trees, the National Joint Utilities Group Publication Volume 4 "NJUG Guidelines for the Planning, Installation and Maintenance of Utility apparatus in Proximity to Trees" should be followed. Relevant extracts of this publication are reproduced in NG1.10.
- S1.10.2 In addition to the recommendations of the NJUG guidelines, the use of tree root barriers may be considered. Specialist advice from an arboriculturist should be sought.

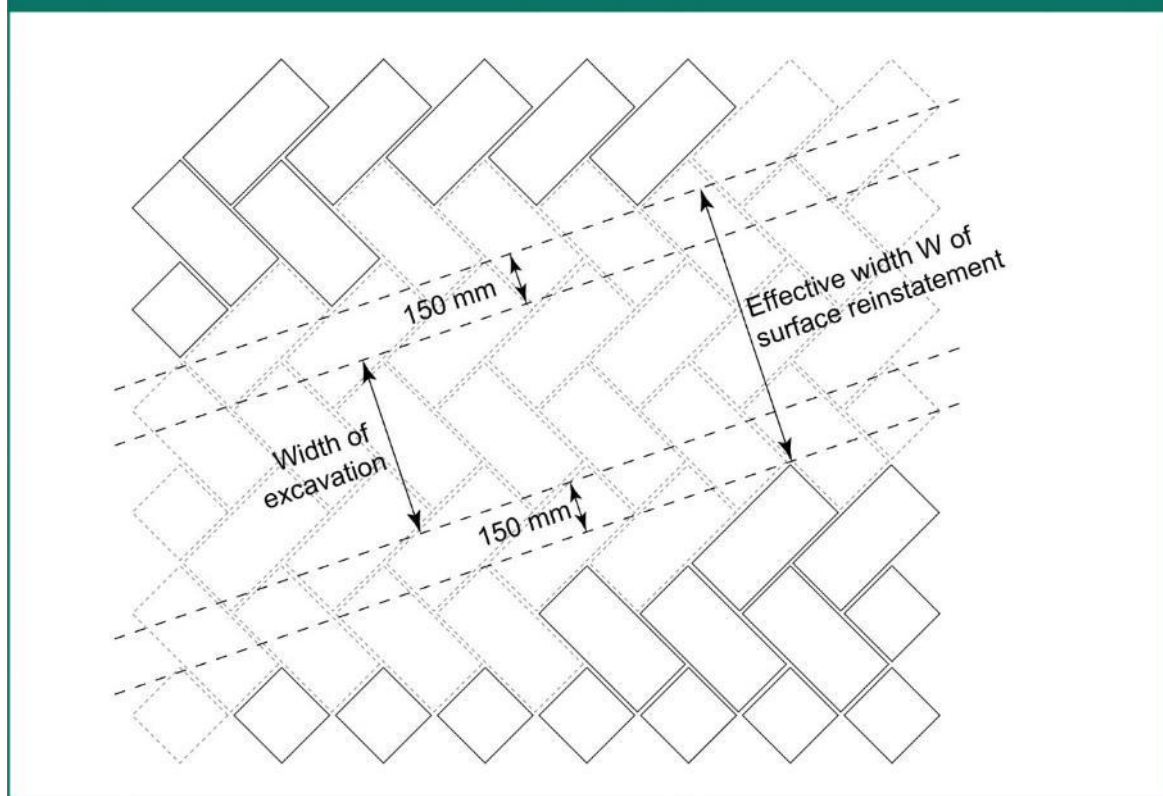
S1.11 Conciliation and arbitration

- S1.11.1 This Code is intended to provide sufficiently detailed guidance to enable agreement on its operation and implementation to be reached at local level. Authorities and undertakers should always work collaboratively and use their best endeavours to achieve a solution to disputes without having to refer them to conciliation. This might be achieved by referring the issue to management for settlement.
- S1.11.2 If agreement cannot be reached, the provisions set out in the *Code for the Co-ordination of Street Works and Works for Road Purposes and Related Matters* should be followed.

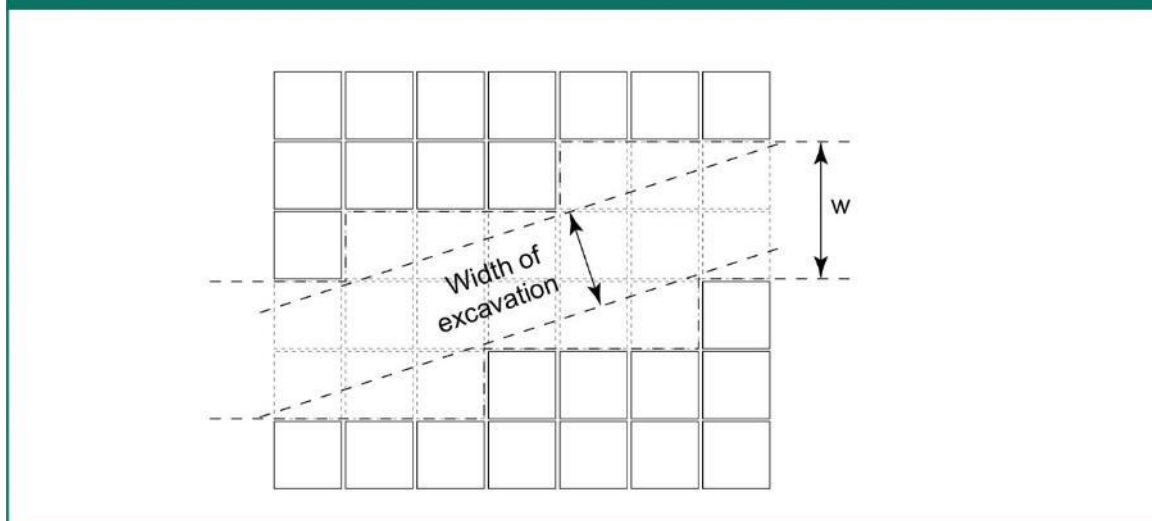
S2 Performance requirements

S2.1 General

- S2.1.1** The performance requirements of this Code apply to streets that are maintainable at public expense. In all other cases, the performance should match that of the existing construction, as far as reasonably practicable.
- S2.1.2** The performance requirements apply to immediate, interim and permanent reinstatements. For all interim reinstatements, the main consideration for meeting the requirements set out in S2 is maintaining highway safety. This is particularly important where deferred set mixtures (DSMs) are used in roads, especially the higher traffic road categories.
- S2.1.3** If the reinstatement exceeds any intervention limit set by S2 during any guarantee period, remedial action must be carried out to return it to the as-laid condition defined in S2.2.1.
- S2.1.4** No new guarantee period is required unless the cumulative settlement intervention limit is exceeded, and an engineering investigation has been completed in accordance with S2.5. Requirements for the re-excavation and subsequent reinstatement, as determined from the results of an engineering investigation, must be agreed and completed in accordance with S2.5.
- S2.1.5** Reinstatement of modular surface layers is described in A12. For modular surfaces the effective width of a reinstatement is as follows:
- 1) For modular surfaces where all sides of the module are 305 mm or less, the effective width of the reinstatement (W) is the distance between two parallel lines drawn 150 mm outside the edges of the excavation (see Figure S2.1a).

Figure S2.1a Surface area of reinstatement – modules ≤ 305 mm

- 2) For modular surfaces where any side of the module is greater than 305 mm, the effective width of the reinstatement (W) is the distance between the outer extremities of any modules that overlap the edge of the excavation (see Figure S2.1b).

Figure S2.1b Surface area of reinstatement – modules > 305 mm

- 3) Where there is evidence of adjoining modules being affected by the excavation, the effective width must be extended to include them.

S2.1.6 Surface deformation resulting from vehicles over-running reinstatements within paved footways, including footpaths and cycle tracks, must be excluded from all measurements carried out for the purposes of monitoring

the reinstatement surface performance unless such reinstatements have been carried out under the provisions of S8.7.

- S2.1.7 Paved footways and their reinstatements can be reasonably expected to withstand occasional overrun by vehicles less than 1.5 tonnes unladen. Where it can be shown that occasional over-run by such vehicles has caused surface deformation to a reinstatement within a paved footway and the adjacent surfaces do not show any associated surface deformation, the authority may notify the undertaker accordingly, whereupon the undertaker must restore the reinstatement to the as-laid profile.

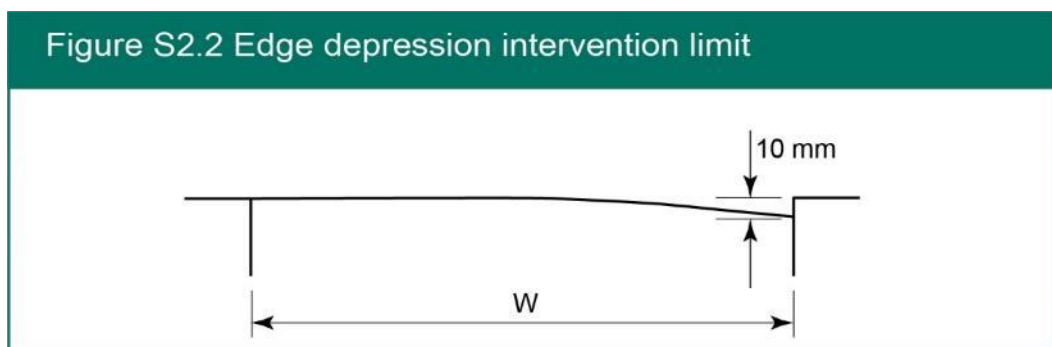
S2.2 Surface profile

As-laid profile

- S2.2.1
- 1) The reinstatement surface must be flush with the surrounding surfaces. There should be no significant depression or crowning present. The construction tolerance at the edges of a reinstatement is ± 6 mm.
 - 2) Once the reinstatement is registered as completed and opened to traffic, the intervention limits in S2.2.2 to S2.2.7 apply.
 - 3) During the guarantee period, where the profile of the surfaces adjacent to the reinstatement is uniform but the surface of the reinstatement is outside the intervention limits, the undertaker must carry out remedial works to restore the surface of the reinstatement to match the adjacent surfaces.
 - 4) It can be difficult to match a new surface to adjacent surfaces when using hand tools on reinstatements in restricted areas (e.g. around surface boxes). In such cases, localised variations in the hand-laid surface profile should be acceptable to the authority provided that they are within the specified tolerances.

Edge depression

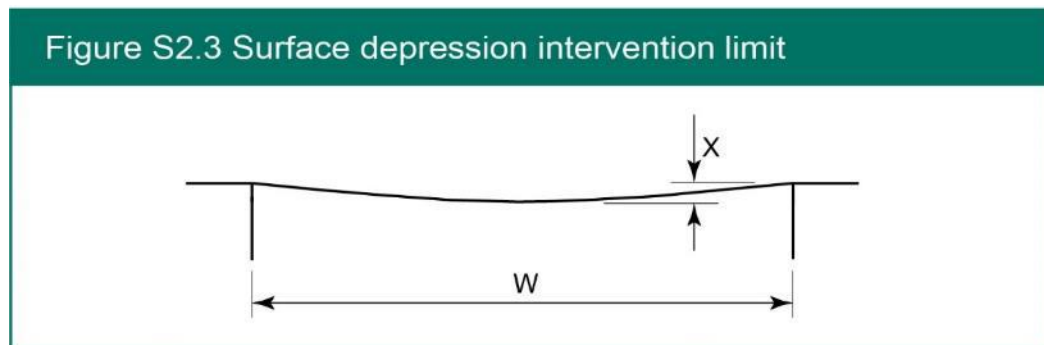
- S2.2.2 An edge depression is a level difference at the interface of a reinstatement and the adjacent surface or ironwork. Intervention is required where the edge depression exceeds 10 mm over a continuous length of more than 100 mm in any direction; see Figure S2.2.



Surface depression

- S2.2.3 A surface depression is a depressed area in a reinstatement having generally smooth edges and gently sloping sides; see Figure S2.3.

Intervention is required where the surface depression spanning more than 100 mm in any plan dimension exceeds the intervention limit X shown in Table S2.1.



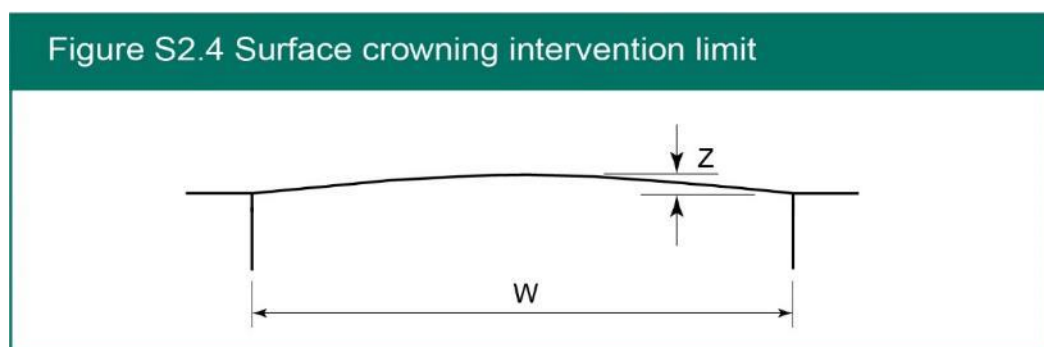
S2.2.4 Earlier intervention is required if the depression alone results in standing water wider than 500 mm or exceeding 1 m² in area, at 2 hours after the cessation of rainfall.

Table S2.1 Intervention limits for surface depression

Reinstatement width W (mm)	Intervention limit X (mm)	Combined defect intervention limit (mm)
Up to 400	10	10
Over 400 to 500	12	10
Over 500 to 600	14	12
Over 600 to 700	17	14
Over 700 to 800	19	16
Over 800 to 900	22	18
Over 900	25	20

Surface crowning

S2.2.5 Surface crowning is where the reinstatement lies above the mean level of the adjacent surfaces; see Figure S2.4. Intervention is required where the surface crowning spanning more than 100 mm in any plan dimension exceeds the intervention limit Z shown in Table S2.2.



S2.2.6 Earlier intervention is required if crowning alone results in standing water wider than 500 mm or exceeding 1 m² in area, at 2 hours after the cessation of rainfall.

Table S2.2 Intervention limits for surface crowning

Reinstatement width W (mm)	Intervention limit Z (mm)	Combined defect intervention limit (mm)
Up to 400	10	10
Over 400 to 500	12	10
Over 500 to 600	14	12
Over 600 to 700	17	14
Over 700 to 800	19	16
Over 800 to 900	22	18
Over 900	25	20

Combined defect

S2.2.7 A combined defect is an area in a reinstatement where any combination of edge depression, surface depression or crowning exists. Intervention is required where any of the individual defects, spanning more than 100 mm in any plan dimension, exceeds the combined defect intervention limit for the relevant defect, as defined in Table S2.1 and Table S2.2.

Condition at end of guarantee period

S2.2.8 At the end of the guarantee period the condition of a reinstatement is not required to be superior in any respect to the condition of the adjacent surfaces.

S2.3 Fixed features

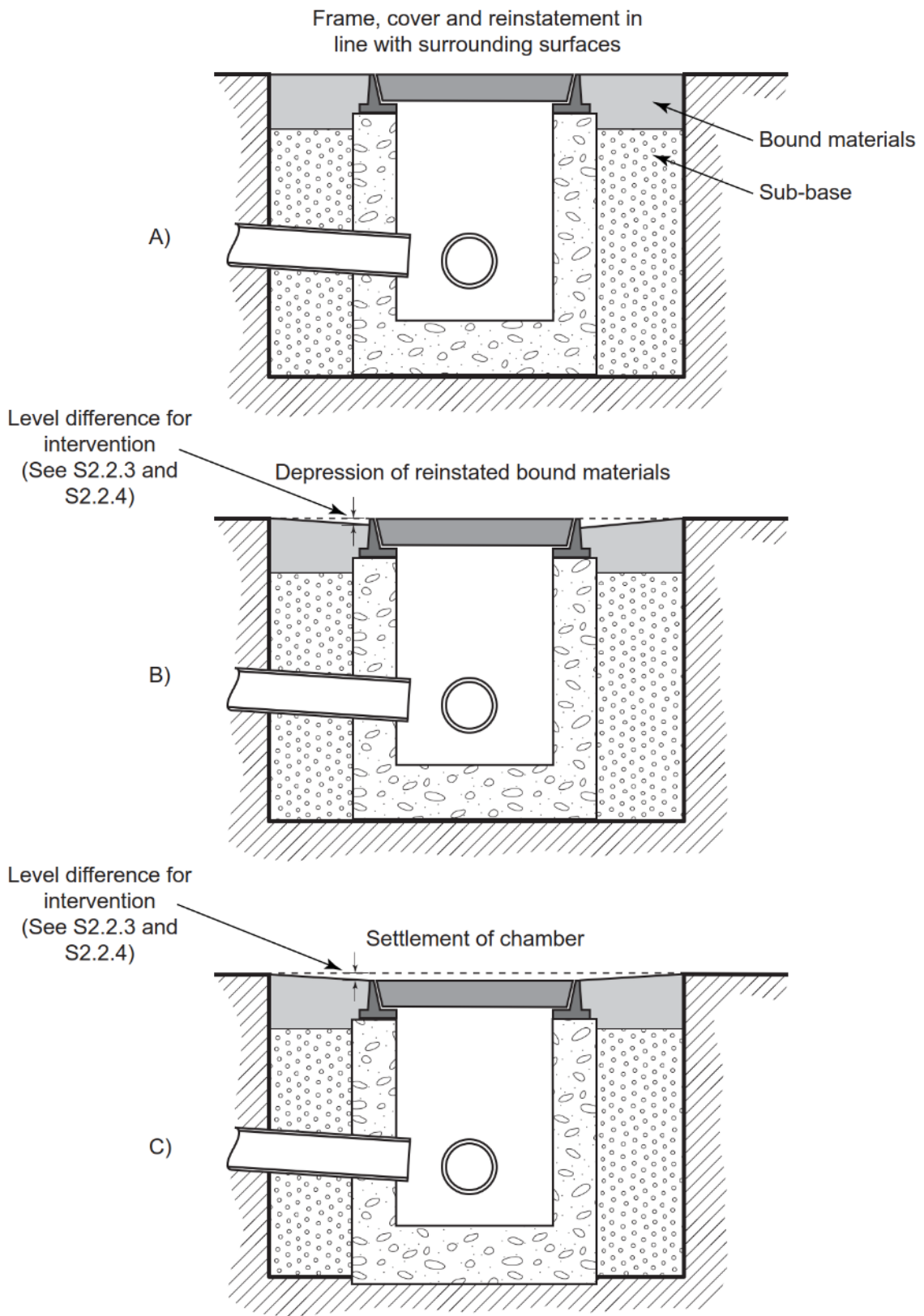
As-laid profile

S2.3.1 All fixed features, such as edgings, channel blocks, drainage fixtures, surface boxes and ironware etc., should be as level and flush as possible with the adjacent surfaces and must be installed to the following level criteria:

- 1) Fixed features must be laid to coincide with the mean level of immediately adjacent surfaces.
- 2) The construction tolerance between the level of the fixed feature (excluding drainage features) and immediately adjacent surfaces is ± 6 mm.
- 3) Drainage features must be installed flush with or up to 6 mm below the level of the adjacent surface.
- 4) At pedestrian crossing points where the kerb is flush with the carriageway, the kerb must be re-laid flush with, or not more than 6 mm above, the carriageway.

S2.3.2 Figure S2.5 illustrates the relationship between immediately adjacent surfaces and the surround reinstatement when setting the level of access covers and frames.

Figure S2.5 Fixed features relative to adjacent surfaces



Intervention

- S2.3.3** Intervention is required where the mean level of edgings, channel blocks, surface boxes and ironware etc., do not coincide with the mean level of the adjacent surfaces, within ± 10 mm.
- S2.3.4** For drainage fixtures, intervention is required where the feature differs from the mean level of the adjacent surfaces, within a tolerance of +0 mm to -15 mm.
- S2.3.5** For pedestrian crossing points, intervention is required where the edge depression at the interface between the paving (including tactile paving) and the dropped kerb exceeds 6 mm over a continuous length of more than 100 mm in any direction.

S2.4 Surface regularity

Requirements

- S2.4.1** At any time during the guarantee period, the surface regularity in the direction of traffic flow of a permanent reinstatement in the road and the adjacent wheel track must comply with the following requirements:
- 1) The number of longitudinal surface irregularities along a permanent reinstatement should not exceed the lower limit shown in Table S2.3.

Table S2.3 Surface regularity

Surface irregularities not less than (mm)	Irregularities per section		
	Lower limit	Multiplier	Upper limit
4	11	1.2	22
7	2	1.2	4
10	1	1.2	2

- 2) Where the number of longitudinal surface irregularities along a permanent reinstatement exceeds the lower limit in Table S2.3, the number of irregularities in the direction of traffic flow along the adjacent wheel track must be recorded for comparison.
- 3) Where the number of surface irregularities along a permanent reinstatement and the adjacent road both exceed the lower limit shown in Table S2.3, the number of longitudinal surface irregularities recorded along the reinstatement should not exceed the product of the number measured along the adjacent road and the multiplier shown in Table S2.3.

Measurement

- S2.4.2** Surface irregularities may be measured using a rolling straightedge. However, a rolling straightedge cannot be used to determine surface regularity where:
- 1) The line of a trench is parallel to the centreline of the road for less than 30 m; or

- 2) The line of a trench is parallel to the line of traffic flow for less than 30 m; or
- 3) The line of a road or trench follows a bend with a radius of less than 250 m; or
- 4) The number of surface irregularities recorded along the adjacent road exceeds the upper limit shown in Table S2.3.

Where the rolling straightedge cannot be used, the surface regularity must be assessed by another agreed method (e.g. 3 m straightedge).

Monitoring

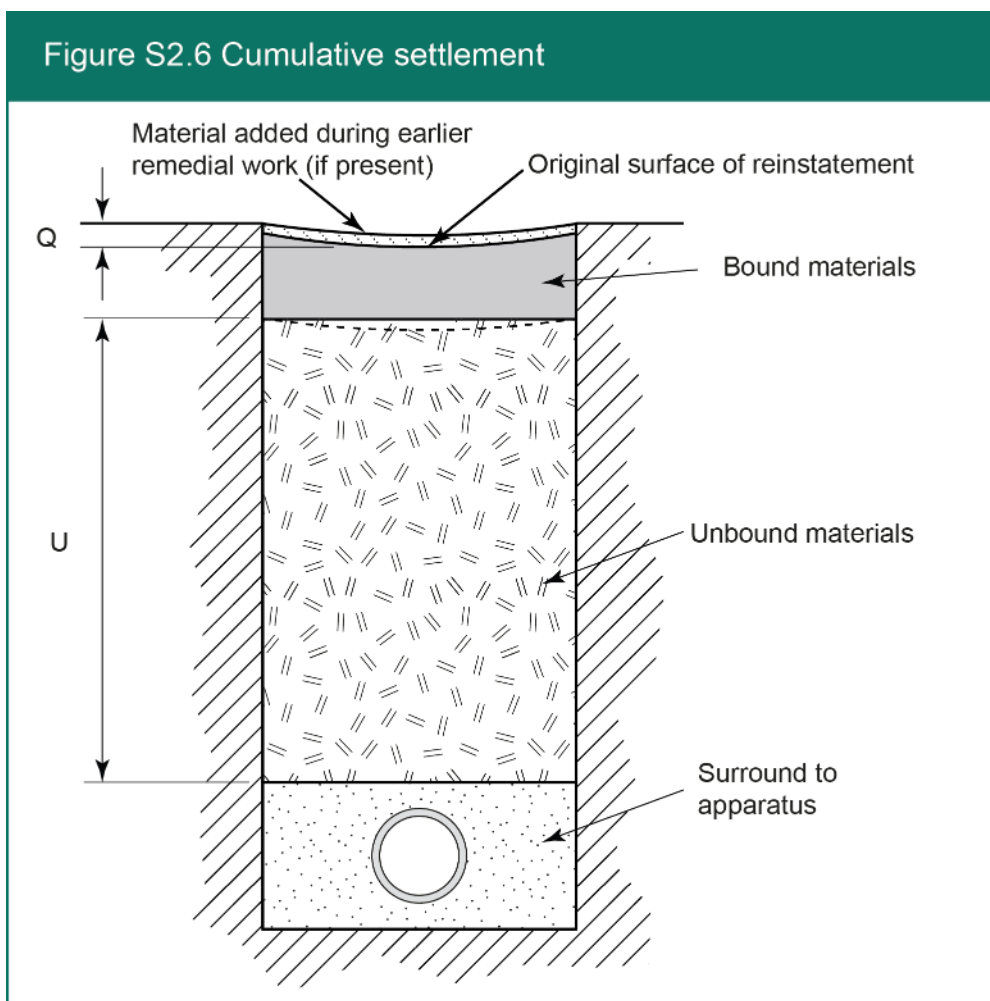
- S2.4.3** For the purposes of monitoring the surface regularity of road reinstatements, relevant lengths of the trench should be divided into test sections 30 m long. The upper and lower limit values for surface irregularities for each 30 m section are shown in Table S2.3. For the final section, which may exceed 30 m but will be less than 60 m, the limits should be calculated pro rata and rounded up to the nearest whole number.

S2.5 Structural integrity

The requirements for structural integrity are applicable to both paved and unpaved surfaces.

Cumulative settlement

- S2.5.1** The cumulative settlement of a reinstatement is the level difference, Q , between the adjacent surfaces and the original surface of the reinstatement – see Figure S2.6. This measurement will include the thickness of any materials added during any preceding remedial work.



- S2.5.2** If the cumulative settlement of a reinstatement exceeds the limits shown in Table S2.4 at any time within the guarantee period, an agreed engineering investigation must be carried out jointly with the authority. The investigation should establish whether settlement is likely to continue and determine the extent of remedial action required.

Table S2.4 Structural integrity

Reinstatement width (mm)	Intervention limit Q	
	Normal ground conditions	Bad ground conditions
Up to 1000	1.5% U or 30 mm whichever is greater	2.5% U or 30 mm whichever is greater
Over 1000	1.5% U or 35 mm whichever is greater	2.5% U or 35 mm whichever is greater

- S2.5.3** Where it is necessary to re-excavate a reinstatement to carry out an engineering investigation, the subsequent permanent reinstatement is deemed to be new and the guarantee period begins again.
- S2.5.4** Where very deep excavation work is carried out in bad ground, consideration should be given to an agreed extension of the interim reinstatement period. An appropriate extension will allow the reinstatement and surrounding ground to achieve an acceptable degree of stability

before permanent reinstatement is required. The performance requirements of S2 apply throughout the extended interim period.

Bad ground

S2.5.5 Bad ground is deemed to be natural or made-up ground between the base of the excavation and the binder course level that contains any of the following:

- 1) Class E Unacceptable materials, as specified in A1.5.
- 2) Materials that are loose or friable in their natural state and are not self-supporting at an exposed face.
- 3) An excessive amount of rocks or boulders, loose random rubble, penning, setts or cobbles etc, at any depth where their removal during excavation could cause loosening of the ground adjacent to the excavation.
- 4) Materials that are saturated, regardless of whether free or running water is present.

S2.6 Skid resistance

General

S2.6.1 The texture depth, Polished Stone Value (PSV) and Aggregate Abrasion Value (AAV) at the running surface of all interim and permanent reinstatements in all roads must comply with the following:

- 1) There is no requirement to provide a texture depth, PSV or AAV that is superior to that of existing running surfaces adjacent to the reinstatement.
- 2) For rigid roads, where the surface of the concrete is the running surface and it has been randomly grooved, a brushed surface finish to the requirements of Table S2.5 and Table S2.6 is permitted for small openings, narrow trenches and other openings less than 1 m wide.

Texture depth

S2.6.2 1) Subject to the requirements of S2.6.1, for bituminous surface course materials permitted in A2, and rigid roads where the surface of the concrete is the running surface, the texture depth must comply with the requirements of Table S2.5 and Table S2.6.

Table S2.5 Texture depth

Reinstatement location	Texture depth (mm)			
	Chipped HRA and surface dressings	SMA and TSCS	All other bituminous surfaces	Concrete carriageways
Roads where speed limit \geq 60 mph	1.5 average 1.2 minimum	1.3 average 1.0 minimum	0.6 minimum	See Table S2.6
All other roads	1.0 average 0.8 minimum	1.0 average 0.8 minimum	0.6 minimum	1.25 maximum 0.6 minimum

Table S2.6 Texture depth for concrete carriageways on roads where speed limit \geq 60 mph

Time of test	Required Texture depth (mm)		
		Specific value	Tolerance
Between 24 hours and 7 days after the construction of the slab or until the slab is first used by vehicles	An average of 10 measurements	1.00	± 0.25
Not later than 6 weeks before the road is opened to public traffic	An average of 10 measurements	1.00	+0.25 -0.35

2) The definitive method for measuring the average depth of carriageway surface macrotexture in this Code is the volumetric patch technique as per BS EN 13036-1 described in MCHW Clause 921 for bituminous surfaces and Clause 1026 for concrete surfaces. For concrete or narrow reinstatements, a modified version using 50% of the test medium (e.g. sand or glass beads) may be used.

3) Laser based macrotexture measurement devices correlated against the definitive method may be used as a supplementary method only (e.g. for rapid assessment before a targeted test plan using the definitive method). For the purposes of monitoring texture depth, the entire reinstatement must be divided into areas of 18 m² and tested as follows:

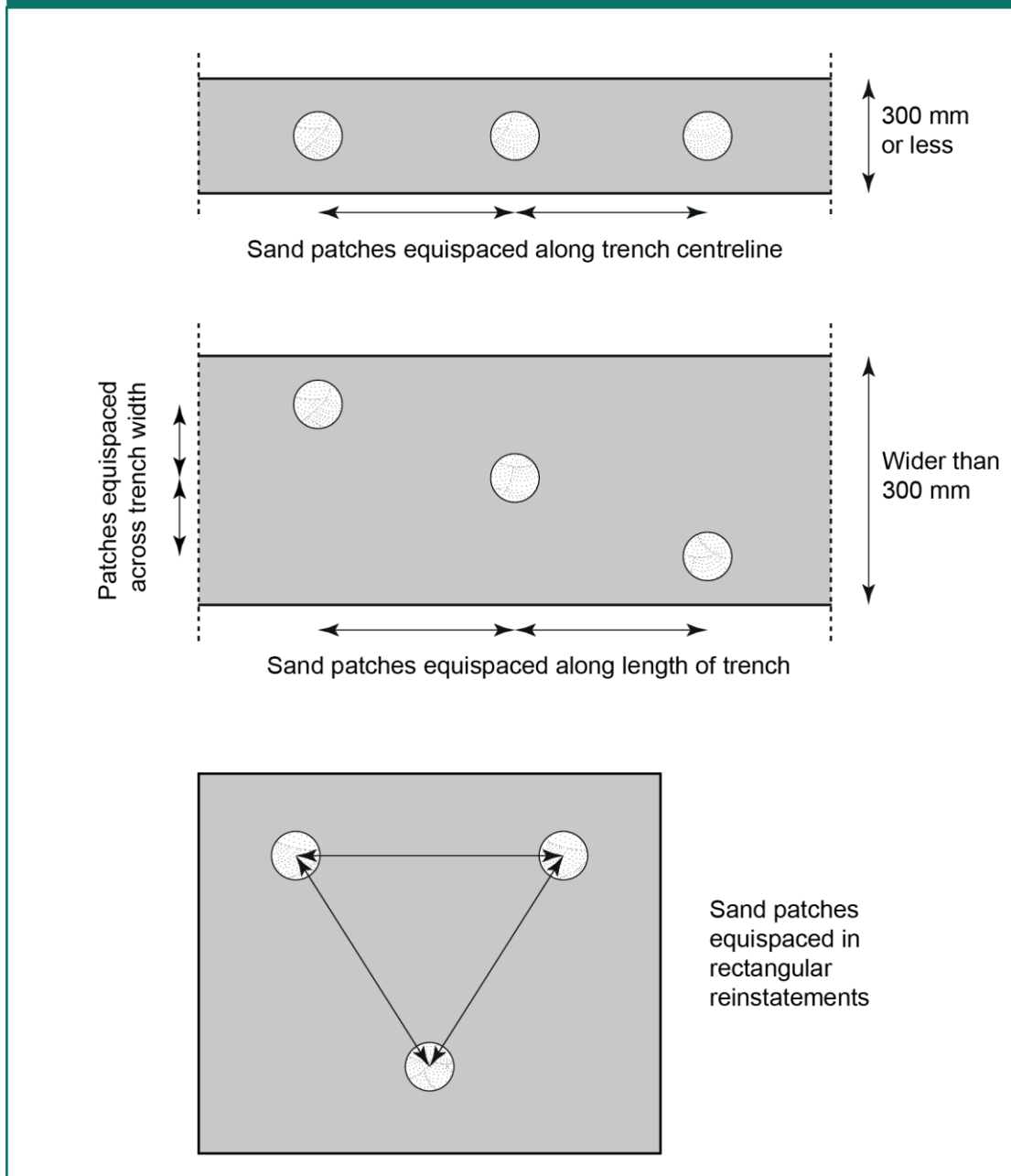
- 1) Reinstatement of small openings – single measurement centred within the reinstatement.
- 2) Reinstatement of >4 m² to 18 m² – 3 measurements.
- 3) Reinstatement >18 m² – 3 measurements per 18 m².
- 4) Trenches 300 mm wide or less – as above but positioned along the centreline of the trench.

Figure S2.7 illustrates the above requirements except for small openings.

4) Where the test patch extends beyond the edge of the reinstatement, the test must be repeated using half the volume of the test medium. Any comparison tests on the existing road should be carried out adjacent to the

test locations in the reinstatement, and as close to the reinstatement edge as practicable.

Figure S2.7 Sand patch testing - typical locations



Polished Stone Value (PSV)

- S2.6.3 1) To simplify the determination of the PSV requirements for aggregates in asphalt surface courses, reinstatements in roads are classified into two site categories according to the apparent degree of risk associated with the site location, as follows:

Site A – Potentially high risk

Includes:

- 1) Traffic signals, pedestrian crossings, railway level crossings – including 50 m approaches

- 2) Roundabouts and their exits - including 50 m approaches
- 3) Bends < 100 m radius where the speed limit is more than 40 mph (65 km/h) – including 50 m approaches
- 4) Downhill gradients over 10% for more than 50 m (single or dual carriageway)
- 5) Uphill gradients over 10% for more than 50 m (single carriageway only)

Site B – Average to low risk

All other situations on single and dual carriageways, including the following:

- 1) Generally straight sections of carriageway
 - 2) Approaches to and across major/minor road junctions
 - 3) Bends of 100 m radius or greater, at any speed limit
 - 4) Downhill/uphill sections of 10% gradient or less
- 2) Subject to the requirements of S2.6.1, for all bituminous surface course materials permitted in A2, the PSV of all pre-coated chippings and the coarse aggregate in all mixes used without pre-coated chippings at the running surface must comply with the requirements of Table S2.7. The coarse aggregate in all mixes used with pre-coated chippings at the running surface must have a minimum PSV of 45. The PSV must be tested in accordance with BS EN 1097-8.

Table S2.7 Bituminous roads – Polished Stone Value

Road type	Reinstatement minimum PSV	
	Site A Potentially high risk	Site B Average to low risk
0	68	68
1	68	65
2	65	60
3	65	53
4	65	53

Note: Limestone coarse aggregate is not normally used in the running surface of roads (PD 6691+A1, 2016); therefore, its use is only permitted by agreement.

3) Past use of these site categories and Table S2.7 has indicated that the minimum values noted are appropriate in most cases. However, where an authority has alternative requirements for aggregate properties (e.g. part of the DMRB or a published policy), this information must be supplied to the undertaker. Where this is the case the undertaker must specify aggregate properties in accordance with this information subject to S2.6.1 (1).

4) Where an interim surface course contains an aggregate that may not comply with the requirements of Table S2.7, a surface treatment may become necessary before the reinstatement is made permanent. In this

case, the requirements of Table S2.7 are applicable only to the coarse aggregate contained in the surface treatment and not the underlying aggregate in the interim surface course.

5) Where a high friction coating is to be applied to a reinstatement to match an existing coating, an alternative PSV may be specified, by agreement, in place of the requirements of Table S2.7, depending upon the nature of the site and the period over which the friction coating will be absent.

6) Where a permanent surface course contains more than one type of aggregate or aggregates from more than one source, all coarse aggregates within the mixture must comply with the PSV requirements of Table S2.7.

Aggregate Abrasion Value (AAV)

- S2.6.4 1) Subject to the requirements of S2.6.1, for all bituminous surface course materials permitted in A2, the AAV of all pre-coated chippings and the coarse aggregate in all mixes used without pre-coated chippings at the running surface must comply with the requirements of Table S2.8.

Table S2.8 Bituminous roads – Aggregate Abrasion Value

Road type	Reinstatement maximum AAV	
	All pre-coated chippings	All surface course mixtures to PD6691
0	10	12
1	12	14
2	12	14
3	14	16
4	14	16

(See also S6.4 for permitted surface course options)

2) The AAV must be measured in accordance with BS EN 1097-8.

3) Where an interim surface course material contains an aggregate that may not comply with the requirements of Table S2.8, a surface treatment may become necessary before the reinstatement is made permanent. In this case, the requirements of Table S2.8 are applicable only to the coarse aggregate contained in the surface treatment and not to the underlying aggregate in the interim surface course.

4) Past use of Table S2.8 has indicated that the minimum values noted are appropriate in most cases. However, where an authority has alternative requirements for aggregate properties then this information must be supplied to the undertaker. Where this is the case the undertaker must specify aggregate properties in accordance with this information subject to S2.6.1(1).

S2.7 Sampling and testing

- S2.7.1 All sampling and testing must be carried out by a laboratory holding current UKAS accreditation covering the specified method of testing, unless otherwise agreed.
- S2.7.2 The authority may carry out sampling and testing at its discretion. If there is no agreement between the authority and undertaker on the test results and findings, further testing may be undertaken by a UKAS accredited laboratory to reconcile the matter.

S2.8 Works in deteriorated or distressed areas

- S2.8.1 It can be difficult and sometimes impossible to construct a compliant reinstatement where:
- 1) existing surfaces are close to or exceed the intervention and construction tolerances in S2; or
 - 2) the road, footway, footpath or cycle track shows signs of deterioration or distress (either at the surface or during excavation); or
 - 3) the existing construction is under designed (e.g. layers are thinner than specified in this Code),
- S2.8.2 If at any stage, constructing a compliant reinstatement is not considered possible, it is the undertaker's responsibility:
- 1) to record the condition of the existing surface (ideally before excavation) and structure;
 - 2) to demonstrate risk management of the works to avoid or limit damage to comply with the specification (including the use of flowable materials, or enhanced materials as per A2.3 for surface course reinstatements, to avoid disruption of the surrounding structure during compaction);
 - 3) if practicable, to contact the authority and agree an appropriate reinstatement method.
- S2.8.3 Where there is no agreement, or reaching one is impractical owing to time constraints, the undertaker must provide evidence of the existing condition to the authority and explain why the reinstatement may not comply with the specification.
- S2.8.4 Where the undertaker has explained to the authority why the reinstatement may not comply with the specification:
- 1) the undertaker is under no obligation to extend the reinstatement works but must ensure that there is no edge depression (see S2.2.2) after construction;
 - 2) the undertaker must repair cracking (see S12.3) and settlement beyond reinstatement limits (see 12.4) that occur during the reinstatement works.
 - 3) for modular surfaces, it may be necessary to install different sized modules or cementitious infills (see A12.2.7 and A12.2.8) to minimise surface irregularities at the interfaces to meet the requirements of S2.
- S2.8.5 If, in the absence of an agreement on an appropriate reinstatement method, the reinstatement fails during the guarantee period, local

resolution should be sought in the first instance, or in any case, the hierarchy of resolution via the provisions set out in S13 of the *Code for the Co-ordination of Street Works and Works for Road Purposes and Related Matters* should be followed (see S1.11).

S3 Excavation

S3.1 Breaking the surface

- S3.1.1 Care must be taken when cutting surface layers to avoid undue damage to the running surface or to the bond between the surface course and binder course. Cutting by machine, e.g. road saw, coring equipment or planer, is preferred. All loose materials must be removed to ensure that the excavated edge is in a safe and stable condition.
- S3.1.2 When excavating in modular construction, the existing modules must be lifted carefully and stored for re-use. Where existing damage has resulted in fragmentation or breakage of modules made out of natural materials, the fragments must be removed and stored unless agreed otherwise with the authority.
- S3.1.3 When any material that may be of a historical or archaeological interest is identified (including natural material, cobbles or setts) excavation must stop. The authority must be informed as soon as possible and afforded the opportunity to inspect the material.
- S3.1.4 Modules must be reinstated in accordance with A12.

S3.2 Excavation

- S3.2.1 Excavation should be carried out in a manner that avoids undue damage to the surrounding area. If, before works commencing, an undertaker feels that it is unavoidable, they should contact the authority as soon as possible to discuss the best way forward. Furthermore, if damage is caused they should inform the authority immediately so that an appropriate reinstatement method can be agreed (also see S2.8).
- S3.2.2 Trench widths should be such that adequate access is available for placement and, where non flowable materials are used, compaction of the surround to apparatus.
- S3.2.3 Trench walls should be even and vertical with no undercutting of the running surface. If undercutting occurs and compaction is impossible, measures should be taken to fill any voids as soon as practicable or immediately after trench support has been provided.
- S3.2.4 Excavations must be protected, as far as is reasonably practicable, from the ingress of water, and water running into them must be drained or pumped to an approved disposal point. Any drainage sumps must be sited to prevent damage to the excavation.

S3.3 Excavated material

- S3.3.1 Excavated materials that are to be re-used should be protected from excessive drying or wetting during storage. Additionally, these materials should be excavated, stored, handled and laid to avoid contamination, segregation and loss of fines.
- S3.3.2 Excavated material unsuitable for re-use must be removed from site as soon as practicable. Excavated material retained on site must be stockpiled within the confines of site barriers, at a safe distance from the trench edge and prevented from entering any drainage system or water course.

S3.4 Side support

- S3.4.1 The sides of excavations in soft or loose ground must be provided with a side support system in most cases. The support system must be designed and installed to restrain lateral movement of the walls and should be installed without delay.
- S3.4.2 Supports must be progressively withdrawn as backfilling and compaction progresses, and all voids carefully filled.

S3.5 Drainage

- S3.5.1 The undertaker must take all reasonably practicable measures to prevent the permanent disturbance of artificial or natural drainage systems/paths. Where disturbance does occur, it must be notified immediately to the owners of the system and any landowners who are affected. Disturbed systems must be restored to the requirements of the owner; see S11.4.
- S3.5.2 For any works site where the authority is aware of a history of flooding or drainage problems, it should inform the undertaker in advance. In such situations the undertaker and the authority should liaise closely to identify a suitable method of working.
- S3.5.3 If site conditions indicate to the undertaker that the use of some reinstatement materials may be detrimental to drainage, advice on the selection of suitable materials should be sought from the authority.
- S3.5.4 See also S11.4 for other water-related matters.

S3.6 Shallow or aborted excavations

- S3.6.1 No shallow or aborted excavation is permitted to undermine the integrity of the remaining road structure. Any prematurely terminated excavation must be reinstated in accordance with the following requirements:
- 1) Where reinstatement can be achieved by laying a thicker surface course in accordance with A2, or S6.6 in the case of micro trenches, or S6.5 in the case of small openings and narrow trenches, no further excavation is required.

- 2) In all other cases, the binder course must be excavated to allow a binder course layer to be reinstated in accordance with A2. Where the existing depth of excavation is greater than 100 mm and the additional depth is less than the minimum layer thickness of base material, a thicker binder course may be laid.
- 3) In deeper excavations, no further excavation is required. Reinstatement must be carried out in accordance with the relevant requirements of S5 to S9, as appropriate.

S3.7 Mole ploughing and trenchless pipelaying

- S3.7.1** Mole ploughing uses a ploughing machine to pull a flexible pipe or cable below ground. It is employed in unmade ground and may be used in verges. The mole plough creates a slit in the surface of the ground which should not require reinstating provided that the surface profile is restored in accordance with S9. However, where connections are made to apparatus installed by mole ploughing, excavations must be carried out and reinstated in accordance with this Code.
- S3.7.2** Soil displacement moling and other trenchless methods do not create an excavation and, when carried out in a proper manner, do not require reinstatement. However, at launch and receive pits and at any intermediate excavations where connections are made to apparatus, reinstatement must be carried out in accordance with this Code.
- S3.7.3** Where, as a result of the use of trenchless methods, the authority has reasonable cause to believe that damage may have been caused to the structure of the road, footway, footpath or cycle track, the Investigatory Works Procedure described in the HAUC Code of Practice for Inspections should be commenced as if the defect was associated with a reinstatement defect for the purposes of that Code.
- S3.7.4** Any remedial work agreed between the authority and the undertaker to be necessary must be carried out in accordance with this Code and at the undertaker's expense if carried out by the undertaker. If the agreed remedial work is carried out by the authority at the undertaker's expense, the provisions of this Code do not apply.
- S3.7.5** In the absence of agreement between the authority and the undertaker, liability for any damage must be determined in accordance with section 82 of the Act (liability for any damage or loss caused).

S4 Surround to apparatus

S4.1 General

- S4.1.1 Surround to apparatus may be laid to a maximum thickness of 250 mm above the crown of the apparatus. The surround to apparatus must not intrude into the road structure. It may be necessary for the undertaker to lay apparatus deeper to avoid this.
- S4.1.2 Laying and compaction procedures used for all materials laid as surround to apparatus are the responsibility of the undertaker.
- S4.1.3 Selecting materials for the surround to apparatus is the responsibility of the undertaker. All materials used for the surround to apparatus must comply with the following requirements:
- 1) Class E Unacceptable materials, as defined in A1.5, and materials that contain particles greater than 37.5 mm nominal size cannot be used as surround to the apparatus.
 - 2) Hydraulically bound materials (HBMs) complying with A10.2 are permitted within the surround to apparatus as the entire layer or combined with any other permitted materials, in any proportion, within any reinstatement.
 - 3) An alternative reinstatement material (ARM) may be used for the entire surround to apparatus or any part thereof, in accordance with A9.
 - 4) Preformed modules or other protective measures may be placed within the surround to apparatus, according to the undertaker's requirements.

S5 Backfill

S5.1 Backfill material classification

General

S5.1.1 Backfill materials, whether imported or sourced from excavated materials, are classified as follows:

Class A – Graded granular materials

S5.1.2 Materials with a maximum of 10% by mass passing a 63 µm BS sieve, and with all material passing a 425 µm BS sieve showing a plasticity index of 6 or less, determined in accordance with BS 1377-2: Method 5.4, are classified as Class A graded granular materials.

S5.1.3 Class A Graded Granular Materials may include Type 2 Unbound Mixtures to MCHW Clause 804 (excluding natural sands and gravels) and Type 1 Unbound Mixtures to MCHW Clause 803.

S5.1.4 Class A Graded Granular Materials may also include the Modified Type 1F Unbound Mixture specified in A10.1. This is the preferred unbound material. This type of unbound mixture cannot be used if direct trafficking of the backfill could occur during construction.

Class B – Granular materials

S5.1.5 Materials with a maximum of 10% by mass passing a 63 µm BS sieve.

Class C – Cohesive/granular materials

S5.1.6 Mixtures of granular, silt and clay materials with between 10% and 80% by mass passing a 63 µm BS sieve.

Class D – Cohesive materials

S5.1.7 Clay, silt or mixtures of clay and silt with at least 80% by mass passing a 63 µm BS sieve.

Class E – Unacceptable materials

S5.1.8 Materials listed as unacceptable in paragraphs 2 ii) and 3 of MCHW Clause 601 cannot be used at any level in the permanent structure of any reinstatement. Materials classified as unacceptable are listed in A1.5.

FCRs and HBMs

S5.1.9 FCRs and HBMs, complying with A2.5.3 to A2.5.18 and A10.2 respectively, are permitted within the backfill as the entire layer or combined with any other permitted backfill materials, in any proportion, within any reinstatement. These materials are classified as Class A for the purposes

of determining the requirements for sub-base reinstatement in accordance with S6.2.

S5.1.10 The requirements of A1 apply to unbound backfill materials.

S5.1.11 Backfill materials Classes A to D must be compacted in accordance with A8. HBMs must be compacted in accordance with A10.2. and FCR as per A2.5.16.

S5.2 Alternative reinstatement materials (ARMs)

S5.2.1 ARMs may be used for the entire backfill layer, or any part thereof, in accordance with A9.

S5.3 Additional requirements

Frost heave susceptibility

S5.3.1 Frost susceptible material is deemed to be material with a mean heave greater than 15 mm when tested in accordance with BS 812-124 (as amended by MCHW Clause 801.8).

S5.3.2 Where frost susceptible materials exist within 450 mm of the surface, such materials may be reinstated to the same levels but, generally, frost susceptible material must not be used within 450 mm of a road surface. However, 300 mm of wholly bituminous material is considered to provide adequate insulation and may be used as an alternative.

S5.3.3 In the event of prior notification by the authority, where the existing depth of non-frost susceptible materials is more than 450 mm below the road surface and the authority requires such a thickness of non-frost susceptible material to be maintained, only non-frost susceptible materials can be used for the relevant depth.

S5.3.4 All frost heave susceptibility testing must be carried out by a laboratory holding current UKAS accreditation for the specified method of testing, unless otherwise agreed.

Maximum particle size

S5.3.5 The maximum particle size for granular materials used as backfill must comply with the following requirements:

- 1) All granular backfill materials must pass through a 75 mm BS sieve.
- 2) All granular backfill materials used in the reinstatement of trenches less than 150 mm wide must pass through a 37.5 mm BS sieve.

Surround to apparatus as backfill

S5.3.6 Where the excavation depth does not allow the use of a separate backfill layer, the sub-base layer must be laid directly onto the surround to apparatus. In such cases, the surround material represents backfill material and must be classified in accordance with Figure S5.1 for the purposes of determining the requirements for sub-base reinstatement in accordance with S6.2.

Protective measures to apparatus

S5.3.7 Preformed modules or other protective measures may be placed within the backfill, according to the undertaker's requirements.

Chalk

S5.3.8 Imported chalk materials used as backfill must comply with the following requirements:

- 1) The saturation moisture content must be determined before use.
- 2) The chalk must be laid and compacted to an approved compaction procedure developed in accordance with NG1.6 (4) and A9. The compaction procedure must be proven with chalk materials of similar saturation moisture content.

S5.3.9 Excavated chalk to be re-used as backfill must comply with the following requirements:

- 1) Excavated chalk must be stockpiled for re-use and must not be subjected to multiple handling.
- 2) During wet weather, excavated chalk must be protected against water ingress at all times.

S5.3.10 Chalk materials must be assessed by breaking up excavated fragments by hand or by driving a steel pin into unexcavated deposits, and classified in accordance with Table S5.1. If the classification falls between two densities, then the chalk must be assumed to be at the lower of the two densities.

Table S5.1 Suitability of chalk materials for use as backfill

Chalk density	Physical assessment	Backfill suitability
High	Very difficult/impossible to break up by hand Difficult to hammer in steel pin.	Carriageways, footways and verges.
Medium	Some difficulty in breaking up by hand. Some effort needed to hammer in steel pin.	Footways and verges only.
Low	Easy to break up or crush by hand. Steel pin can be pushed in by hand.	Unsuitable for use in any reinstatement.
<p>Note: Chalk often contains flint inclusions and care should be taken to ensure that:</p> <ol style="list-style-type: none"> a) the steel pin does not strike a flint b) the hand crushing sample does not contain any flints. 		

S5.3.11 Chalk materials must be compacted in accordance with A8.2.

S6 Flexible and composite roads

S6.1 Reinstatement methods

General

- S6.1.1 The undertaker must carry out reinstatement in accordance with one of the following methods and should endeavour to achieve the greatest degree of immediate permanent reinstatement. Reinstatement methods are listed in Table A2.10.
- S6.1.2 Permitted materials and layer thickness are specified in A1 to A4, A9 and A10.
- S6.1.3 Where the authority knows of any site with aggressive ground conditions, for example high sulphate levels, it must advise undertakers in advance of the works so that appropriate measures may be taken.

Method A – All permanent reinstatement

- S6.1.4 The excavation must be reinstated to a permanent standard at the first visit.

Method B – Permanent binder course reinstatement

- S6.1.5 The backfill, sub-base, base and binder course must be reinstated to a permanent standard at the first visit.
- S6.1.6 The permanent binder course material, or an alternative interim material, must be extended to the surface as the interim surface course, with or without a thin separating material layer of sand at the position of the binder course/surface course interface.
- S6.1.7 On the second visit, all interim surfacing materials must be removed to the top of the binder course, typically by cold planing, and a permanent surface course must be laid.
- S6.1.8 Where a sand separation layer is present, the sand must be removed, the surface brushed clean and a bond coat applied before reinstating the permanent surface course.

Method C – Permanent base reinstatement

- S6.1.9 The backfill, sub-base and base must be reinstated to a permanent standard at the first visit.
- S6.1.10 The interim surface course and part or all of the interim binder course may be deferred set material. Part or all of the entire interim binder course may be an unbound granular material.

- S6.1.11 On the second visit, all interim surfacing materials must be removed to the top of the base, and a permanent binder course and surface course must be laid.

Method D – Permanent sub-base reinstatement

- S6.1.12 The backfill and sub-base must be reinstated to a permanent standard at the first visit
- S6.1.13 The interim base must be granular and the interim surfacing must be in accordance with the requirements of S6.1.9 to S6.1.11.
- S6.1.14 On the second visit, all interim materials must be removed to the top of the sub-base, and a permanent base, binder course and surface course laid.

Method E – Permanent reinstatement incorporating interim surface overlay

Not applicable

Other reinstatement methods

- S6.1.15 S6.5 must be followed for small openings and narrow trenches. For micro trenches, large diameter cores and work around ironwork, S6.6, S6.7 and S11.5 must be followed respectively.

Alternative reinstatement materials

- S6.1.16 ARMs may be used in flexible and composite roads in accordance with A9.

S6.2 Sub-base reinstatement

General

- S6.2.1 Permitted options are shown in Figures A3.6, A4.5 and A4.6, subject to the following exceptions:
- 1) Sub-base equivalence: thickness of granular sub-bases may be reduced provided that the thickness of the bituminous binder course is increased proportionately, in accordance with S6.3.7.
 - 2) Small openings and narrow trenches: in composite roads with a CBGM base, this material may also be used as a sub-base regardless of whether the existing sub-base is cement bound.

S6.3 Base reinstatement

General

- S6.3.1 Permitted options are shown in A3 and A4, subject to the following exceptions:

CBGM base in flexible and composite roads

- S6.3.2 All composite roads constructed with a base of CBGM, lean-mix concrete or equivalent must be reinstated with a CBGM base.

S6.3.3 CBGM base must either be C16/20 (to Table A14 in BS 8500-1) or comply with the following:

- 1) the aggregate requirements for MCHW clause 822
- 2) particle size distribution of the mixture in accordance with BS EN 14227-1 CBGM 1 (0/20 or 0/14),
- 3) R_{Rc} must be ≥ 80 as per A10.2.14 and
- 4) the following strength requirements which are dependent on coarse aggregate type:
 - a) crushed rock aggregate: C8/10;
 - b) other sources of coarse aggregate (including gravel): C12/16

S6.3.4 Where a CBGM base is used, the reinstatement must:

- 1) be designed to be suitable for immediate overlay (see requirements in A10.2) for immediate overlay; or
- 2) have achieved a compressive strength of C3/4 (curing of samples used to determine the minimum compressive strength suitable for overlay must be representative of the site conditions) before overlay; or
- 3) be trafficked and overlaid depending on the road type, as follows:
 - a) in Types 0 and 1 roads, the CBGM base may either be surfaced on the same day or allowed 7 days curing. In either case, the CBGM base must be allowed 7 days curing before trafficking.
 - b) in Types 2, 3 and 4 roads, the CBGM base may either be surfaced on the same day or allowed 3 days curing. If the surface is placed in the same day, the road may be opened to traffic the following day.

S6.3.5 In composite roads, the reinstated CBGM base must be laid flush with the top of the existing CBGM, lean-mix concrete or equivalent.

S6.3.6 Continuously reinforced concrete bases that have been connected with dowel bars are not covered in this Code. Special conditions will apply and the reinstatement method must be agreed with the authority.

Base equivalence

S6.3.7 In Type 3 and 4 flexible roads, the thickness of granular bases may be reduced provided that the thickness of the bituminous binder course is increased proportionately in accordance with the following requirements:

- 1) Each 10 mm increase in bituminous binder course thickness is equivalent to a 35 mm decrease in thickness of Type 1 Granular sub-base at base and/or sub-base levels and vice versa.
- 2) This equivalence rule may be applied to include the total replacement of all granular materials at both sub-base and base levels, subject to the following restrictions:
 - a) Binder course and surface course thickness in Type 3 and 4 roads are minimum values and must not be reduced by application of the 10:35 equivalence of bituminous/granular materials; and
 - b) Where part of a granular base or sub-base is to be replaced by additional binder course material, the remaining total thickness of

granular material at base and/or sub-base level must not be less than 150 mm.

Modular materials within the excavation

- S6.3.8 Where cobbles or setts are encountered during excavation, they may be recovered and re-used for reinstatement of the relevant layer. Alternatively, and at the discretion of the undertaker, the layer may be reinstated using CBGM base laid to a thickness of 100 mm, or to match the original thickness, whichever is greater.
- S6.3.9 Modules, cobbles, setts, stones, rocks, or other large aggregate materials laid upright in an interlocking fashion, often termed 'penning', will exhibit a greater stiffness than an equivalent layer of cobbles/setts laid horizontally. Where such upright interlocking modules are encountered, the layer must be reinstated using CBGM base laid to a thickness of 100 mm, or to match the original thickness, whichever is greater.
- S6.3.10 Where surplus modules, cobbles or setts are removed from site, they remain the property of the authority. The undertaker must notify the authority and retain them for 10 days following such notification. Thereafter, the undertaker is free to dispose of them.
- S6.3.11 Where CBGM base is used at base level, it must be used in accordance with S6.3.2 to S6.3.6.

S6.4 Surface reinstatement

- S6.4.1 Permitted options are shown in A2 to A4 inclusive, subject to the exceptions set out in S6.4.

Hot rolled asphalt (HRA) surface

- S6.4.2 Where the existing surface course is HRA it must be reinstated in accordance with one of the HRA surface course options in A2.1, as appropriate for the type of road.

Stone mastic asphalt (SMA) and thin surface course systems (TSCS)

- S6.4.3 Where the existing surface course is SMA or a TSCS the road must be reinstated with either SMA surface course or, at the authority's request, a TSCS or, by agreement, with HRA. These options are subject to the following requirements:
- 1) SMA or TSCS must match the existing nominal aggregate size of the existing surface course material with the exception that 10 mm nominal aggregate size must be used to reinstate SMA/TSCS with 20 mm and 14 mm nominal aggregate size in situations where the hand-laying method is adopted.
 - 2) Preference must be given to the use of TSCS options suitable for the reinstatement works; including consideration of hand installation and compaction.
 - 3) The standard combined thickness of binder course and SMA surface course shown in Figures A3.1 to A3.5 is 100 mm.
 - 4) HRA must comply with the requirements of S6.4.2.

S6.4.4 Edge and base preparation details for permanent SMA reinstatements are as follows:

- 1) All edges must be saw cut or trimmed by saw, to a depth of 40 mm or the thickness of the surface course, before permanent reinstatement.
- 2) A certified bond coat (BS 594987, Clause 5.5) must be applied in accordance with S6.8.
- 3) An edge sealant must be applied in accordance with S6.8.7.

S6.4.5 Where the existing surface is a TSCS and the authority does not want the reinstatement to be completed using SMA, the authority must contact the undertaker and the surfacing material must be agreed in advance.

S6.4.6 Where the authority has a policy to grit or otherwise treat newly laid SMA surfaces, it must advise the undertaker of the required method and materials and the undertaker must comply.

Asphalt concrete surface course materials

S6.4.7 Where the existing surface course is asphalt concrete it may be reinstated with any of the surface course options in A2.

S6.4.8 Where used, asphalt concrete surface course materials must be AC10 close surf, laid 40 mm thick.

Asphalt concrete binder course materials

S6.4.9 Where asphalt concrete binder course is to be used as the running surface for more than 6 months, the usual supplier-declared target binder content must be increased by 0.5%.

Other bituminous materials

S6.4.10 Where it is necessary to use bituminous materials not included in A2, they must be used in accordance with the following:

S6.4.11 *General requirements*

- 1) Where existing road surfaces have been treated or constructed with high friction surfaces, porous asphalt or coloured surfaces, and local custom and practice has been to complete all previous resurfacing with like materials, permanent reinstatement must be carried out in accordance with the following requirements:
 - a) High friction surfaces must be permanently reinstated with like materials, or an agreed alternative, in accordance with S6.4.12.
 - b) In the event of notification by the authority, the reinstatement of any existing porous asphalt surface course (excluding reinstatement of small openings) must be carried out in accordance with the authority's requirements. Small openings must be reinstated as detailed in S6.5.
 - c) Coloured surfaces must be permanently reinstated with like materials, or an agreed alternative material, in accordance with S6.4.14.
 - d) Specific highway authority SMA must be permanently reinstated with SMA complying with S6.4.3 to S6.4.6. If the authority does not want

the reinstatement to be completed using SMA, it must contact the undertaker to agree on the surfacing material to be used.

- 2) Where the overall area is sufficiently large to facilitate machine laying, local custom has been to complete all previous resurfacing with like materials, and the authority wishes to request the use of like materials:
 - a) The authority must notify the undertaker accordingly at the planning or notice stage, or in the case of immediate works, before the permanent reinstatement.
 - b) When requested by the undertaker, the authority must identify an appropriate and reasonably commercially available source of suitable like or alternative materials, wherever possible. Where the authority is unable to identify an appropriate source of suitable material, the undertaker must provide a suitable material on the basis of best reasonable endeavours.
 - c) Where existing road surfaces have been treated or constructed with high friction surfaces, porous asphalt or coloured surfaces, and local custom and practice has not been to complete all previous resurfacing with like materials, the undertaker must consult with the authority to determine appropriate reinstatement requirements.
 - d) Where other specialist surfacing materials not included in A2 or S6.4.11 have been used, in general they may be permanently reinstated in accordance with S6.4.15.

S6.4.12 *High friction surfaces*

- 1) High friction surfaces must be permanently reinstated with a like material within 15 working days following the date of completion of the reinstatement unless the prevailing weather conditions or other site circumstances mitigate against successful application of the surfacing. Where this occurs, the permanent reinstatement must be deferred until unfavourable weather conditions or other site circumstances abate. Circumstances that justify delaying the reinstatement of a high friction surface include the manufacturer specifying that the new surface needs to be trafficked or aged before applying a cold-applied material.
- 2) Before applying any permanent or interim friction surfacing, warning signs must be displayed indicating a potentially slippery road surface.
- 3) All high friction materials must have a certificate from a Product Acceptance Scheme. These materials must be laid in accordance with the manufacturer's instructions by a contractor with suitable experience, as required by the Product Acceptance Scheme for such materials.
- 4) Some high friction surfacing materials have a limited manufacturer's guarantee and may be subject to wear and abrasion during the guarantee period. However, the reinstated area must not be inferior to the adjoining surface during the guarantee period.

S6.4.13 *Porous asphalt (small openings)*

Small openings that do not adversely affect the overall drainage characteristics of the site may be reinstated using SMA subject to the following:

- a) Reinstatement of multiple small openings using SMA must not be closer than 3 m to each other in the principal direction of fall or surface drainage flow.
- b) Porous asphalt surface courses must be reinstated to nominally match the thickness of the existing layer.
- c) The binder course of porous asphalt reinstatements must be HRA.
- d) All edges must be saw cut or trimmed by saw to a minimum depth of 50 mm (or the thickness of the surface course, if greater), before permanent reinstatement.

S6.4.14 *Coloured surfaces*

Coloured surfaces must be permanently reinstated using like materials of equivalent type and similar colour, subject to the following requirements:

- a) Where the coloured surfacing is overlaid onto a road surface, a coloured overlay must be applied to the same thickness.
- b) Where the coloured surfacing is laid full depth, a coloured material must be laid to the same thickness wherever possible and practicable. Where it is not possible or practicable, the coloured surfacing must be reinstated by agreement.
- c) Some high friction surfacing materials that are coloured have a limited manufacturer's guarantee and may be subject to wear and abrasion during the guarantee period. However, the reinstated area must not be inferior to the adjoining surface during the guarantee period.

S6.4.15 *Other specialist surfacing materials and asphalt surface traffic calming structures*

- 1) Specialist surfaces not included in A2 or S6.4.11 must generally be reinstated with SMA.
- 2) All other surfacing materials not covered above, including grouted bituminous materials, traffic calming materials/structures, etc., must be permanently reinstated by agreement.

Surface treatments

S6.4.16 In Types 0, 1 & 2 roads, where an existing surface treatment is readily apparent, the undertaker must reinstate the surface course with HRA as per S6.4.2 unless otherwise requested by the authority. In addition, the undertaker must apply an equivalent surface treatment if practicable and requested by the authority. Where requested by the authority, an appropriate timing and methodology for the works must be jointly agreed in accordance with national specifications and Codes of Practice (e.g. Road Note 39).

S6.4.17 Unless otherwise requested by the authority, surface dressing or other surface treatment is not required in Types 3 & 4 roads when any binder course and surface course option permitted by S6.4 is laid. When requested by the authority, the surfacing layer and equivalent surface dressing or other surface treatment must be agreed in advance of the works.

Coated chippings

S6.4.18 Pre-coated chippings must be as specified in A2.

S6.4.19 Where pre-coated chippings are to be embedded into a road surface, they must be spread to give a chipping density as per BS 594987, notwithstanding the requirements for surface texture specified in S2.6.

Composite roads

S6.4.20 The total combined thickness of the reinstated binder course and surface course must match the existing bituminous thickness. Wherever practicable, the required surface course thickness should be maintained by adjustment of the binder course thickness.

S6.5 Small openings, narrow trenches and access chamber covers

General

S6.5.1 A permanent surface course material in accordance with A2 may be laid in place of a permanent binder course material at base and/or binder course level:

- 1) in narrow trenches and small openings (as defined in S1.5.3 and S1.5.4); and
- 2) within 350 mm of access chamber covers.

S6.5.2 In all other cases, reinstatement in small openings and narrow trenches must comply with the relevant clauses in S6.5.

Compaction

S6.5.3 The preferred method for compaction in small openings and narrow trenches is in accordance with S10. This must be followed unless there are restrictions, such as kerbs, ironwork, street furniture, that do not allow it. Where these restrictions pre-exist, hand compaction may be used, but only if demonstrated to be appropriate. It is deemed appropriate if:

- 1) the width of the reinstatement is the width of the compaction tool sole plate plus a minimum of 30 mm; and
- 2) the performance requirements of S2 are met, unless agreed otherwise with the authority.

S6.5.4 If hand compaction is not demonstrated to be appropriate, Polymer Modified Mastic Asphalt (PMMA) as per S6.5.6 to S6.5.10 may be used.

Materials

- S6.5.5 For narrow trenches and small openings, materials specified in the following sections must be used:
- 1) S6.2 Sub-base reinstatement
 - 2) S6.3 Base reinstatement
 - 3) S6.4 Surface reinstatement
- S6.5.6 In addition, Polymer Modified Mastic Asphalt (PMMA) complying with A2.5.1 and A2.5.2 may be used. This material is a flowable asphalt and typically used around ironwork. No compaction is needed, so demonstrating compliance with S10 is not necessary.
- S6.5.7 PMMA may be used as bedding, backfill or surfacing material as specified in the following clauses. PMMA must be used within the stated location and limitations (including maximum width of the reinstatement) as detailed in the Product Acceptance Scheme certificate.
- S6.5.8 Reinstatements using PMMA must meet the requirements of S2, unless agreed otherwise with the authority.
- S6.5.9 When PMMA is used, Installation and Quality Control Procedures for all systems must be in accordance with an approved certificate from a Product Acceptance Scheme for each system, and with the current method statement. Quality assurance information and the results of all quality control checks carried out on site by the undertaker must be compiled in accordance with the requirements of the certificate.
- S6.5.10 Before installing any bedding, backfill or surfacing material, the receiving surface must be free of loose material and the area must be free of debris, oil, grease, dust or other visible contaminants. All exposed edges and joints must be primed to achieve a proper bond with the existing surface (see S6.8).
- S6.5.11 *PMMA installation*
- 1) Installation of PMMA can only be carried out in dry conditions at a temperature above -5°C, unless otherwise stated in the product certification.
 - 2) Ambient and road surface temperatures, including maximum and minimum temperatures, must be recorded during the installation process for future reference in the relevant street works notice or permit.
 - 3) PMMA can be supplied in block form for re-melting on site or in molten form in purpose-built hot charge transporters. All heating equipment must be suitable for re-melting or transporting the material as appropriate and must be capable of maintaining the mix at the manufacturer's recommended temperature.
 - 4) The PMMA must be placed into the reinstatement leaving a smooth finish with no gaps. The PMMA is left to stiffen and is assessed in accordance with the method of installation detailed in the Product Acceptance Scheme certificate.
 - 5) All exposed edges and joints must be primed to achieve a bond with the existing surface.

- 6) PMMA must be applied in lifts of 30 to 50 mm thick, and within the manufacturer's recommended temperature range. It must be spread to finish flush with the surrounding surfacing.
- 7) PMMA must be finished with a suitable treatment to provide the necessary skid resistance. This may be 6, 14 or 20 mm bitumen coated chippings or 1 to 3 mm calcined bauxite to the specified PSV. These treatments are applied directly to the hot material and when suitably cooled, lightly rolled or tamped to ensure adequate embedment. For footways only, hard stone grit or a stippled roller may be used as an alternative to chippings or bauxite to provide texture for skid resistance purposes.
- 8) PMMA must be allowed to cool to ambient temperature before opening to traffic, as specified in the Product Acceptance Scheme certificate. During the cooling period no disturbance or trafficking of the system is permitted. Assisted cooling during the installation by means of industrial fans may be required. The curing period must be adjusted for the prevailing weather conditions.
- 9) Excess aggregate must be removed at the end of the cooling period but before opening to traffic.

S6.6 Micro trenching

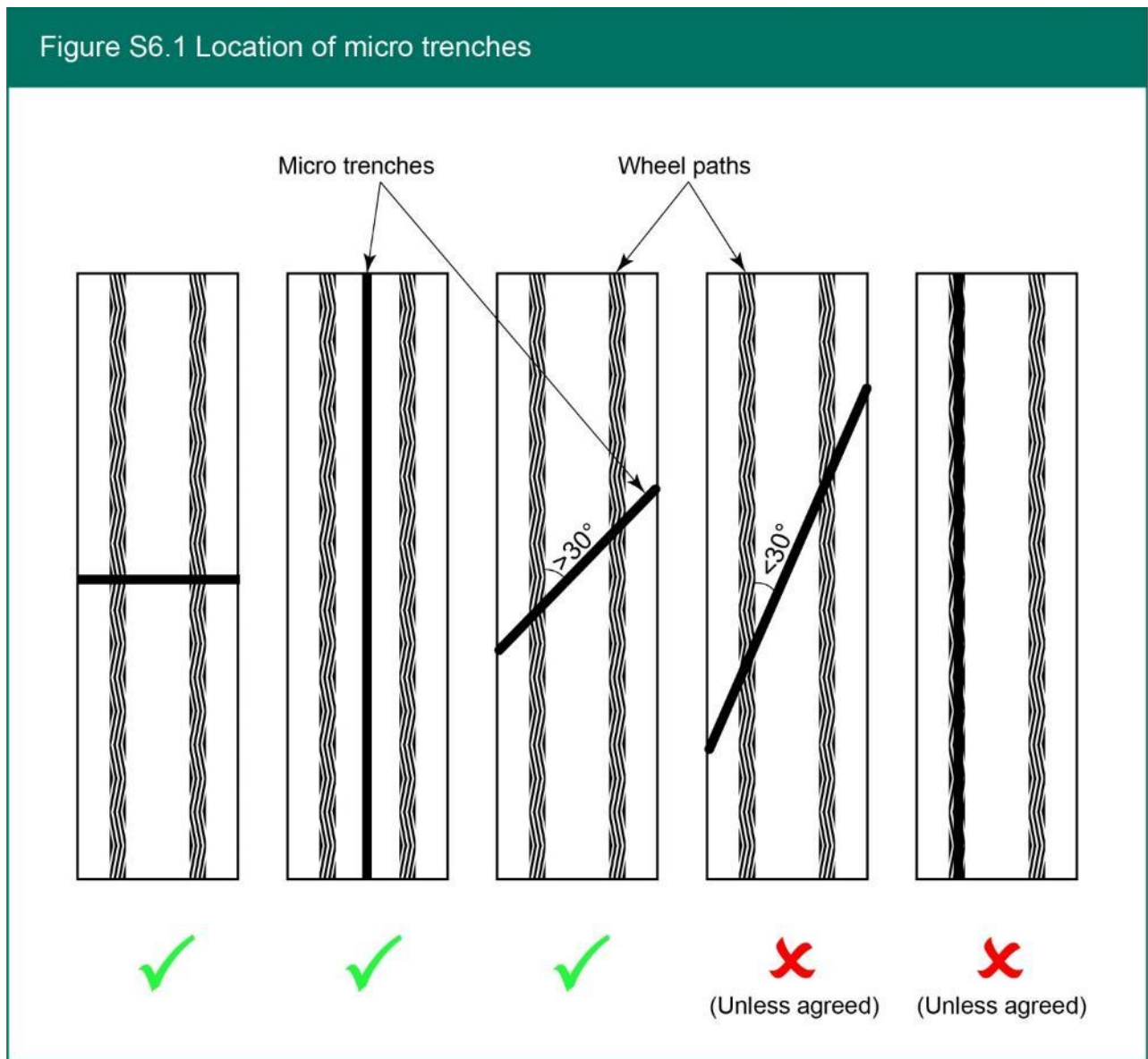
General

- S6.6.1** This section applies to micro trenching in flexible roads, footways, footpaths and cycle tracks (as per S8). It does not apply to micro trenching in verges (S9). Micro trenching in rigid or composite roads, footways, footpaths and cycle tracks requires approval via A9 (materials and technology).
- S6.6.2** Micro trenching is an innovative technique in which ducts or cables can be laid into a slot-cut trench up to 60 mm wide. It is cheaper, quicker and more environmentally friendly than traditional trenching.
- S6.6.3** Micro trenching may be carried out by agreement between the undertaker and the authority. The use of micro trenches cannot be unreasonably withheld by any authority and may only be denied in high duty or high amenity areas or for engineering reasons, e.g. safety, existing condition of the asset, etc.

Excavation/cleaning

- S6.6.4** Slots must be cut to the width of the duct(s) to be accommodated plus a minimum of 2 mm.
- S6.6.5** The minimum depth of excavation must be sufficient to enable reinstatement of the micro trench; including the minimum combined thickness of courses 1, 2 and 3 above the apparatus as specified in S6.6.16.
- S6.6.6** The line of a micro trench must be carefully planned before any excavation takes place. Micro trenches must not be placed under a wheel track zone

in the direction of travel as defined in Figure S6.1 without the agreement of the authority.



- S6.6.7 After cutting to the required depth, the excavation must be cleaned to produce a clear and dry slot.
- S6.6.8 Any large pieces of aggregate or agglomerations of aggregate protruding into the slot after the initial cleaning must be removed or hammered into the base of the slot so that it does not interfere with installation of the duct/cable. This can be done using a percussive tool with a narrow tip.
- S6.6.9 Where cutting or clearing the micro trench causes damage (e.g. visible cracking) or significant vertical or lateral disruption to the surrounding surface, the excavation must be carried out as per S3 and must be reinstated in accordance with S6.2, S6.3 and S6.4 or S6.5, as appropriate. Significant vertical disruption is where the surface has been raised or depressed by more than 6 mm, in line with S2.2.1. It is not necessary to prescribe a limit for lateral disruption as the requirements of S6.8.6 will

prevail. However, the frequency of lateral disruptions must be monitored to determine their significance.

Installation of ducts/cables

- S6.6.10 The duct/cable must be installed in the base of the slot and held in place using clips, plugs of high density foam, or other suitable means.
- S6.6.11 The finished level of the duct/cable must not vary from the agreed depth by more than 20 mm.
- S6.6.12 The duct/cable must incorporate a tracer (often an integral metal wire) to facilitate detection in future.

Backfilling and reinstatement

- S6.6.13 Once the duct/cable and locating strips have been installed, the trench must be reinstated in two or three courses, as follows.
 - 1) Course 1 (conditional only – see below) – granular bedding material
 - 2) Course 2 – indicator infill material
 - 3) Course 3 – surface infill material
- S6.6.14 Where the depth of the micro trench after installation of the duct/cable is greater than the adjacent depth of bound materials, granular bedding material or indicator infill material must be used up to the base of the adjacent bound layers.
- S6.6.15 The indicator and surface infill material must be used within the bound materials.
- S6.6.16 The minimum combined thickness of courses 1, 2 and 3 above the apparatus is 175 mm for roads and 100 mm for footways, footpaths and cycle tracks.
- S6.6.17 If the depth of the micro trench is fully within the bound layers after installation of the duct/cable, only indicator and surface infill material need to be used.
- S6.6.18 Granular bedding is not permitted within the bound layers of the adjacent structure.

Installation

- S6.6.19 *Course 1 – Granular bedding material*
 - 1) Granular bedding material must be vibrated into place using appropriate compaction equipment or tamped by hand. A vibrating plate attached to a steel block with dimensions appropriate to the width of trench and depth to the top of Course 1 may be used for this purpose.
 - 2) If the granular bedding material settles during vibration or tamping such that voids are formed, it must be topped up and re-vibrated or re-tamped as appropriate.
- S6.6.20 *Course 2 – Indicator infill material*
 - 1) This material must be installed using an appropriately shaped funnel or nozzle to completely fill the trench to within 15 mm to 10 mm of the

finished surface level, to create an effective bond on both sides of the slot.

- 2) It must be distinctively coloured to help prevent future works from damaging services in the micro trench.

S6.6.21 *Course 3 – Surface infill material:*

- 1) This is installed above the indicator infill material using an appropriately shaped shoe to completely fill the remaining depth of the trench, to restore the surface profile and to form an overlap seal onto the asphalt surface each side. Unless requested otherwise by the authority, this material must be black or dark grey in colour.
- 2) The overlapping element of the surface infill material must be no more than 3 mm thick. The width of the finished reinstatement must be the slot width plus a minimum of 20 mm either side up to a maximum overall width of 125 mm measured at any single point.
- 3) In carriageways and cycle tracks, before setting, Course 3 must be over scattered with a 3 mm dry, dust free, hard stone aggregate (with a minimum initial PSV of 60) to provide early life skid resistance and texture depth.
- 4) In footways and footpaths, a nominal 1 mm size dry, dust free, hard stone aggregate (with a minimum initial PSV of 60) may be used if requested by the authority.
- 5) Indicator and surface infill materials must be made of the same base resin material and be compatible with each other.

Materials specification

- S6.6.22 Materials used for reinstating micro trenches must comply with A2.6.

S6.7 Large diameter cores

S6.7.1 Large diameter coring is a technique whereby a core greater than 150 mm diameter is cut out of the bound layers of the road surface in one piece and stored for re-use when reinstating the road. Excavation of the underlying unbound material is typically accomplished by vacuum extraction. After work on the apparatus is complete, the unbound material is replaced and compacted, and the extracted core is re-fitted to the road in its original orientation and bonded to the surrounding surface. Reinstatement by re-using the extracted core is a specialist process and is described in S6.7.17.

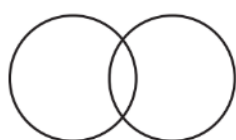
S6.7.2 Large diameter coring is particularly useful for gaining access to individual pieces of apparatus such as buried valves, and it is considerably quicker than conventional excavation and reinstatement methods. The technique should only be considered where the location of buried apparatus is precisely known. It is not permitted where there is a risk of cutting through services located within the bound layers.

S6.7.3 The method of reinstatement by core re-use is only permitted for single cores, two overlapping cores, or multiple cores with a minimum clear separation between core perimeters of 300 mm. The reason for these

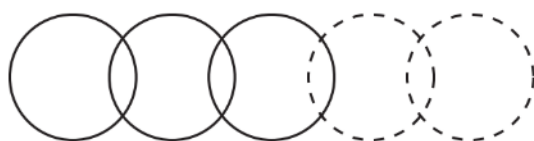
limitations is that three or more overlapping cores present too many bonded cuts to guarantee the integrity of the reinstated surface while very closely spaced cores create compaction problems in the unbound layers.

S6.7.4 As such, where there are three or more overlapping cores or where the separation between multiple cores is less than 300 mm, core re-use is not permitted unless agreed to by the authority (see Figure S6.2). Where this is the case, reinstatement must be carried out in accordance with S6.2, S6.3 and S6.4 or S6.5, as appropriate. Excavations resulting from aborted coring works must be considered as large diameter cores within the above.

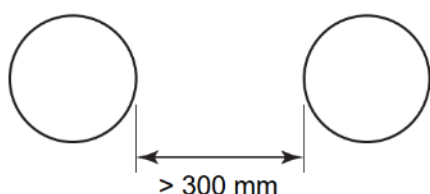
Figure S6.2 Large diameter cores location



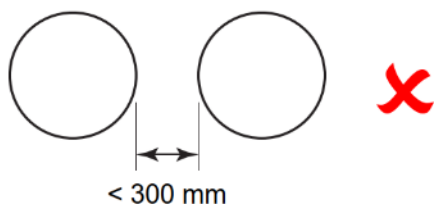
Core re-use is not permitted without the authority's approval when there are more than 2 interlocking large diameter cores (S6.7.4).



In such cases, reinstatement must be in accordance with S6.2, S6.3 and S6.4 or S6.5.



Individual cores are not permitted to be spaced closer than 300 mm without the authority's approval (S6.7.4).



In such cases, reinstatement must be in accordance with S6.2, S6.3 and S6.4 or S6.5.

S6.7.5 Where additional cores are extracted during the same day, the first core must be reinstated before excavating any further cores when the additional cores are within 600 mm of the original core.

Coring and removal of large diameter cores

- S6.7.6** Before cutting the main core, a pilot core (not exceeding 100 mm diameter and located in the centre of the main core) must be taken to determine the depth of the bound layers (or the slab in an unreinforced concrete road). If the depth of the bound layers/concrete slab is less than 100 mm, reinstatement by core re-use is not permitted.
- S6.7.7** Temporary location and alignment marks should be made on the road surface before cutting the main core to ensure that it can be replaced in its original orientation. Care must be taken when cutting surface layers to avoid undue damage to the surrounding surface and binder course.
- S6.7.8** Large diameter coring must only be undertaken with purpose-designed equipment and in accordance with the manufacturer's instructions. The cutter must be positioned perpendicular to the surface and extended to a depth that ensures that all the bound layers are removed as a single core.
- S6.7.9** Care must be taken to minimise dust and debris when core cutting. Water used for cooling the cutter must not contaminate water courses. Where the gradient or camber is significant, this must be considered as part of the overall site-specific risk assessment to ensure the operation can be safely completed.
- S6.7.10** Once the core has been removed, a further check must be undertaken to ensure that the depth of the bound layers is at least 100 mm around the full circumference of the core. If the depth is found to be less than 100 mm, reinstatement by re-using the core is not permitted.
- S6.7.11** *Excavation:*
- 1) Excavation must be carried out in accordance with S3 of this Code. Material may be removed by conventional excavation methods or by air lance and/or vacuum excavation. Irrespective of the method of excavation, care must be taken to avoid undermining the adjoining structure.
 - 2) Where undermining of the adjoining structure does occur, reinstatement by re-using the core is not permitted and reinstatement must be carried out in accordance with S6.2, S6.3 and S6.4 or S6.5, as appropriate. This may require further excavation of the bound layers, in accordance with S3, to enable compaction of the underlying layers.

Materials

- S6.7.12** *Bonding material for large diameter core reinstatement*
- 1) A bonding material certified by a Product Acceptance Scheme must be used. It must meet the requirements of BS 6319-3&7: (Testing of resin and polymer/cement compositions for use in construction) and BS EN 12390-3 (Testing concrete - Compressive Strength of test specimens).
 - 2) The manufacturer's instructions must be followed for the use, preparation and application of the bonding material, in accordance with the Product Acceptance Scheme.

Backfill and granular sub-base compaction

- S6.7.13 Backfill must be selected and placed in accordance with S5.
- S6.7.14 Granular sub-base material must be placed in accordance with S6.2. If the sub-base is bound it will be extracted as part of the core and reinstated in accordance with S6.7.17.
- S6.7.15 A layer of pea gravel may be used to aid levelling of the core. The layer must not exceed 50 mm in thickness at any point.

Core reinstatement and bonding

- S6.7.16 Suitability of extracted core for re-use
- 1) If the core is damaged, it cannot be re-used and the opening must be reinstated in accordance with S6.2, S6.3 and S6.4 or S6.5, as appropriate.
 - 2) A core is unacceptable for permanent reinstatement where any of the following conditions exist:
 - a) It contains any vertical open cracks ≥ 3 mm wide when measured on the face of the core; or
 - b) Horizontal delamination is present in any layer in the core; or
 - c) The core is less than 100 mm deep.
 - 3) If there is any doubt over the integrity of the core, core re-use is not permitted and it must be reinstated in accordance with S6.2, S6.3 and S6.4 or S6.5, whichever are applicable.

S6.7.17 *Reinstatement of removed large diameter core*

- 1) Large diameter cores must be prepared in accordance with the Product Acceptance Scheme of the bonding agent, orientated to their original alignment, and bonded in-situ.
- 2) The procedure for reinstatement must be included in the method statement for the works which must be available if requested by the authority.
- 3) The core must be reinstated so that it is as flush as possible with the surrounding surfaces. The construction tolerance at the edges of the reinstatement is 5 mm maximum at any time within the guarantee period.
- 4) Intervention is required if this tolerance is exceeded or there is any significant visual deterioration in the surface of the core compared with the surrounding surface.

S6.7.18 *Records*

- 1) A record containing the location and details of all large diameter cores must be registered within the relevant street works notice or permit.
- 2) Each core must be registered as an individual reinstatement within the works. For example, for a 600 mm diameter core, reinstatement measures (as registered on the street works notice or permit) should record a measure of 0.6 m x 0.6 m per core extracted. Where two 600

mm cores overlap by, say, 150 mm, the reinstatement should be registered as 0.6 m x 1.05 m (where $1.05 = 2 \times 0.6 \text{ minus } 0.15$).

- 3) There should also be a comment recorded in the works description area of the notice/permit, for example, “Large diameter core hole(s) outside No 1 High Street”.

S6.8 Base and edge preparation

Base preparation

- S6.8.1 All surfaces must be free of contamination before applying the bond coat. This is especially important after the removal of any sand separation layer.
- S6.8.2 A bond coat must be applied to the surface of all bound layers before overlaying in all circumstances.
- S6.8.3 The bond coat must be applied at a rate that ensures a minimum residual bitumen content of 0.15 kg/m^2 .
- S6.8.4 Multiple lifts of the same material laid during a single visit on the same day do not require treatment between lifts. However, a bond coat must be applied before placing the permanent surface course for work carried out in accordance with S6.5.
- S6.8.5 A bitumen emulsion edge sealant may be used as a bond coat in small openings and narrow trenches.

Edge preparation

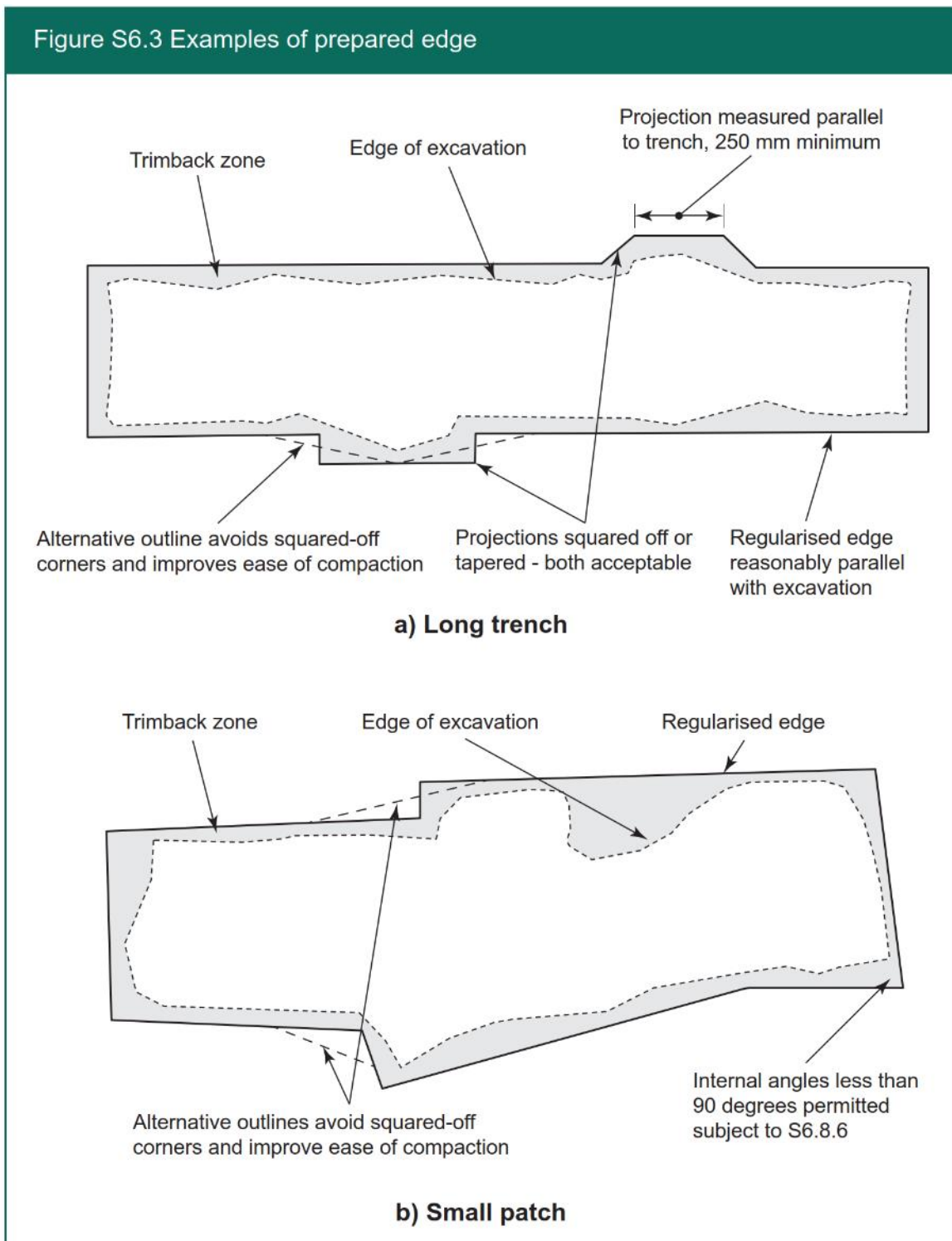
S6.8.6 *Edge regularity*

- 1) Where the existing surface is a bound material, the edges of excavations at the binder or surface course level must meet the following requirements:
 - a) Micro trenches must comply with S6.6.
 - b) Large diameter core excavations must comply with S6.7.
 - c) For all excavations other than micro trenches and large diameter cores, all edges must be essentially straight, smooth and vertical to enable compaction of the reinstatement materials. The preferred methods for this are by saw cut or trimmed by saw.
 - i. Overlapping edge cuts and corner cut outs should be kept to a minimum. All cuts extending into the existing surface must be filled with a flexible bituminous sealant.
 - ii. Internal corners should generally be 90° or more. Where internal corners are less than 90° then compaction equipment must be suitable for achieving compaction in the corners.
 - iii. There is no requirement to trim the sides of trenches solely to provide a uniform width provided that individual projections are not less than 250 mm long when measured parallel to the notional centreline of the trench. See Figure S6.3 (a).
 - iv. There is no requirement to trim small openings solely to provide a square or rectangular shape. Any shape, having no projection less

than 250 mm long, may be considered to be regular. See Figure S6.3 (b).

- v. Where the existing surfacing material is sound at the corners of an excavation, there shall be no necessity to cut out to a corner; a regular chamfer may be preferable.
- vi. The trim-line may be confined to the surface course provided the lower layers have not been damaged. In this case, the surface thickness must match the existing. If the lower layers have been damaged; trim line must include all layers and these must be fully reinstated following the requirements of this Code.

Figure S6.3 Examples of prepared edge



S6.8.7 *Edge sealant*

- 1) For all excavations other than micro trenches, all edges must be adequately prepared before applying edge sealant. This requires:
 - a) the removal of all excess water from the cut face.
 - b) all bound vertical edges to be free of contamination, loose material, slurry or dust, with any cut face of the aggregate in existing layers clearly visible.
 - c) any additional steps detailed in the manufacturer's instructions to be followed when using proprietary products.
- 2) For reinstatement of all excavations other than micro trenches, whether interim or permanent, the top 100 mm at least of all bound vertical edges at surface and binder course levels (and the equivalent area on kerbs and exposed fixed features) must be painted with an edge sealant or prepared with an edge sealing system. No significant splashing, spillage or deliberate over painting of the adjacent road surface is permitted.
- 3) The edge sealant or edge sealing system must comply with the following, if applicable:
 - a) hot bituminous binder must have a penetration of not less than 40 pen;
 - b) hot elastomeric polymer-modified bituminous binder must comply with BS EN 14023 with a penetration of not less than 40 pen;
 - c) if hot bituminous binder is not used, cold applied thixotropic bituminous compound of similar bitumen or polymer-modified bitumen grade may be used, i.e. cold applied aerosols;
 - d) polymer-modified adhesive bitumen strip must have a minimum thickness of 2 mm and must adhere to both cold and warm upstanding edges when the asphalt is applied. The product must be compatible with the material(s) installation process.
- 4) There should be evidence of the use of sealant. Evidence may include visual evidence or quality control records from the reinstatement works.

S6.8.8 *Overbanding*

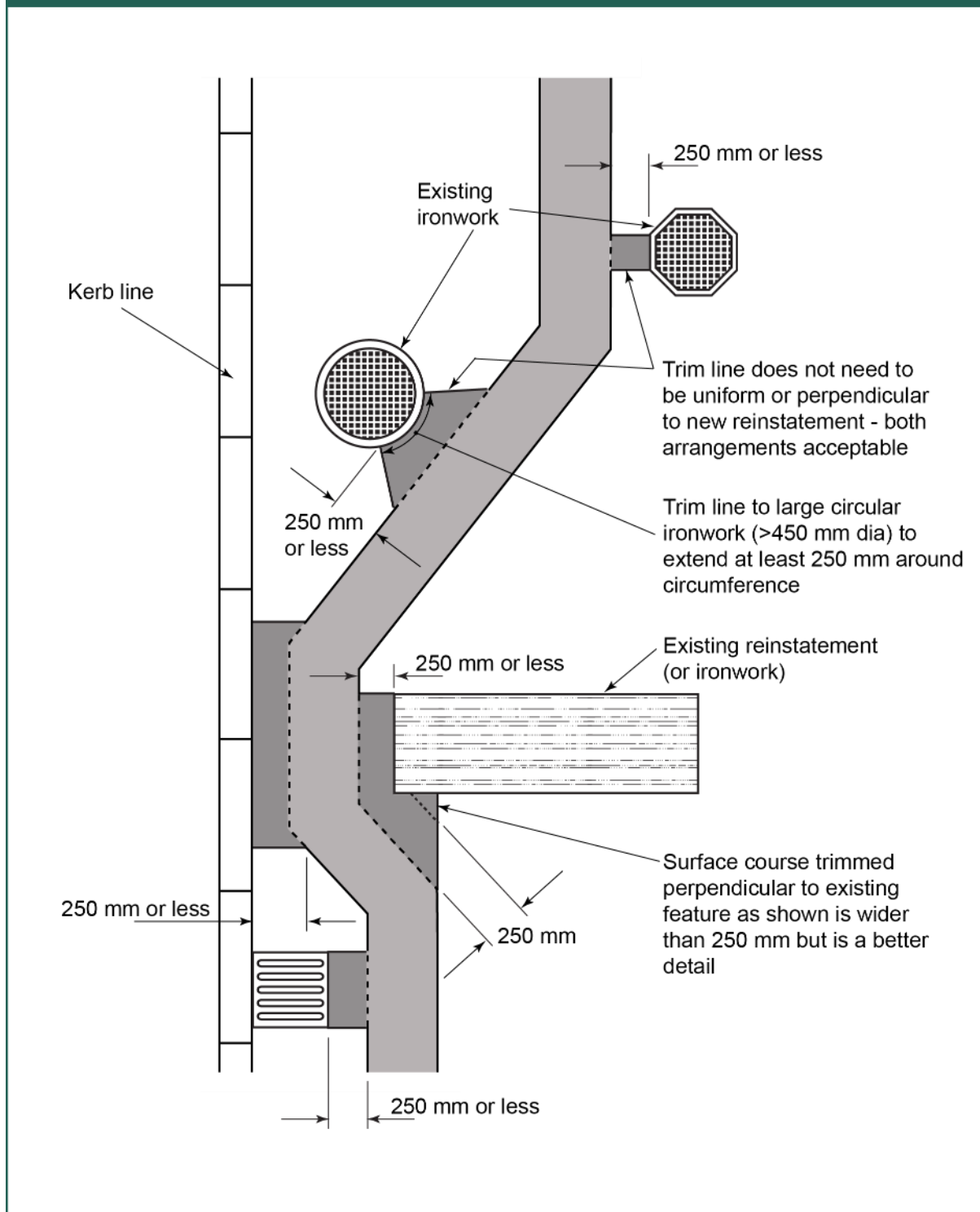
- 1) Overbanding may be used in reinstatements, including remedial works (see S12.3.3) to improve durability. If overbanding is used, it must comply with the reinstatement guarantee period.
- 2) Overbanding must be at least 3 mm wide, no wider than 40 mm, and be no more than 3 mm thick at the surface.
- 3) The overbanding system must have a current certificate by a Product Acceptance Scheme. Alternative certification is required to confirm suitability of use of the overbanding product for its in-service use.
- 4) Hot or cold applied systems may be used, subject to the manufacturer's recommendations.
- 5) Treatments must be black in colour, unless otherwise directed by the authority.

- 6) The minimum PSV for chippings applied to the repair systems is as specified for surfacing (see S2).
- 7) The initial skid resistance must be ≥ 55 SRV as measured by the pendulum tester using the narrow slider in accordance with BS EN 13036-4.
- 8) Installation and Quality Control Procedures for all systems must be in accordance with the Product Acceptance Scheme certificate for each system and the current Method Statement. The results of all quality control checks carried out on site by the undertaker and quality assurance information must be compiled in accordance with the requirements of the certificate.
- 9) Preparation must be in accordance with the installation method statement and must include cleaning and removal of debris and contamination. The substrate must be dried fully before applying crack or joint treatment.
- 10) Overbanding must not be used as a substitute for edge sealing.

S6.8.9 *Proximity to road edges and fixed features*

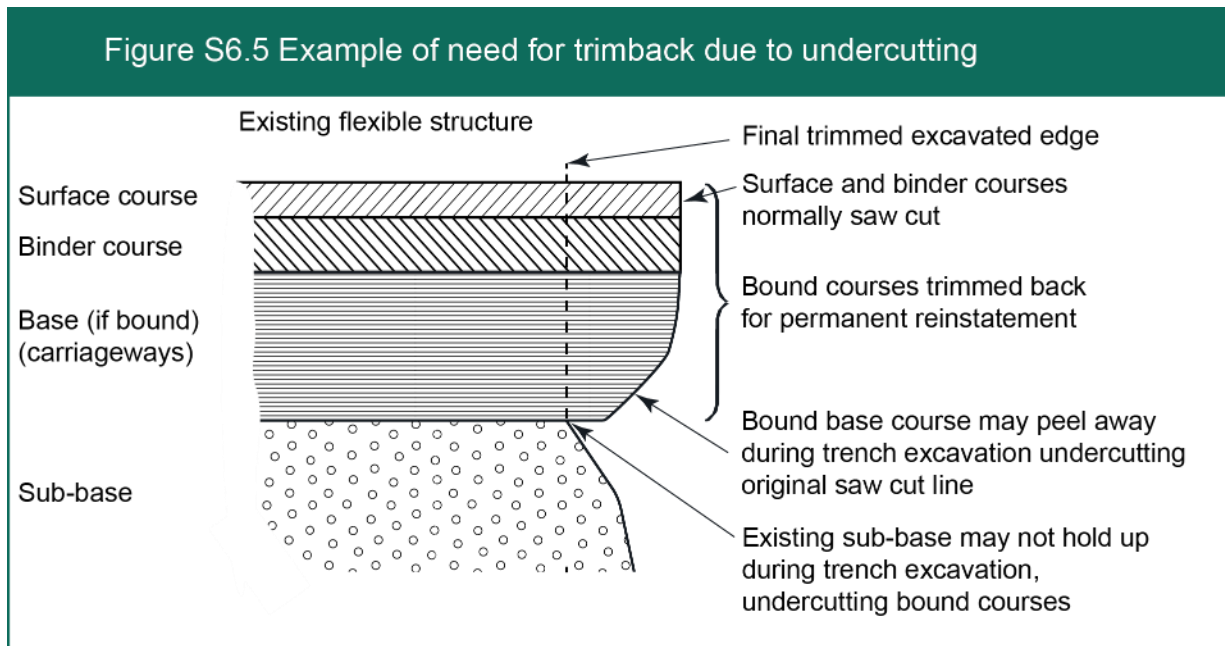
- 1) Where the trimmed edge of any excavation is within 250 mm of the road edge, kerbing, other fixed features or another reinstatement, the trim-line must be extended to the interface with the road edge, kerbing etc. See Figure S6.4.
- 2) The additional reinstatement area required by extending the trim-line may be confined to the surface course provided the lower layers have not been damaged. In this case, the surface thickness must match the existing. If the lower layers have been damaged, the trim line must include all layers and these must be fully reinstated in accordance with this Code.
- 3) Where an existing fixed feature is immediately adjacent to another (e.g. road gully, stop-cock valve cover, etc.) material selection must be appropriate to ensure adequate compaction and surface profile – see S2.2.

Figure S6.4 Edge requirements and trim lines in carriageways



S6.8.10 Undercutting

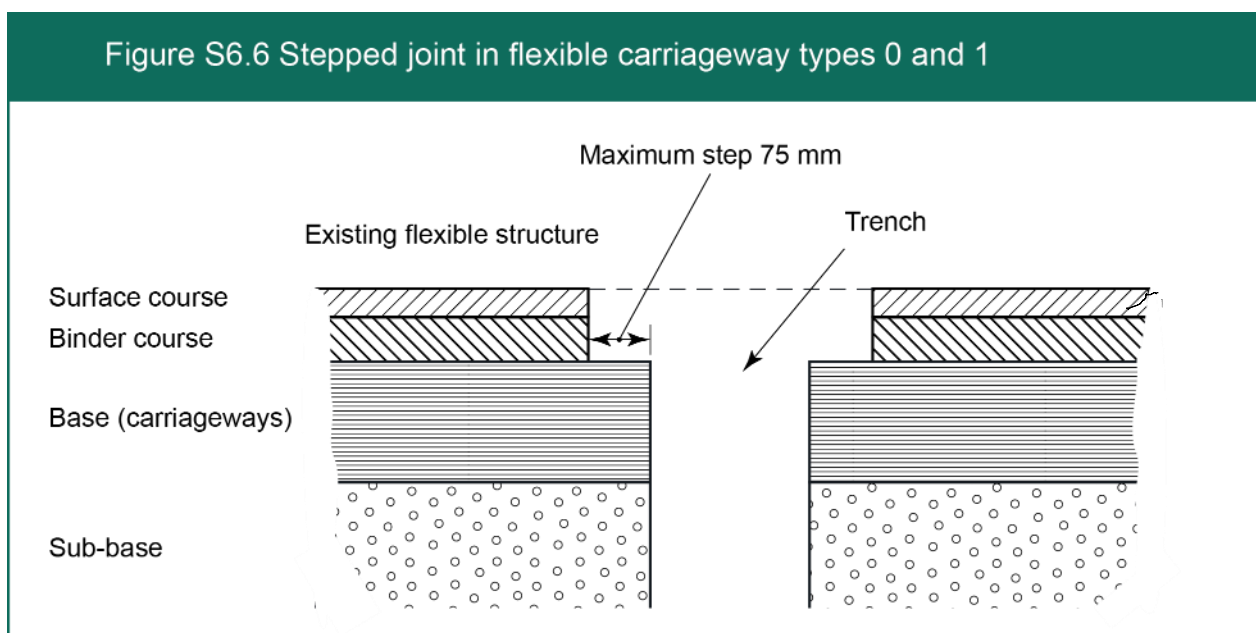
- 1) All bound edges must be fairly smooth and vertical with no significant undercutting, see Figure S6.5.



- 2) There may be no need for trimback when undercutting occurs if PMMA is used as sub-base and base. If an FCR or a FSMR (see A9) is used, then consideration of shrinkage during curing must be demonstrated to ensure support of the overlaying structure.

S6.8.11 Stepped joints

- 1) On Type 0 and 1 roads where it is the custom and practice of the authority to cut-back the surface or binder course to provide a stepped profile, this must be notified to the undertaker. Subject to the agreement of the authority, the stepped joint may be applied to reinstatements in Type 0 and 1 roads subject to the following:
- Large diameter cores, small openings and narrow transverse trenches are excluded.
 - The stepped profile must match the authority's policy subject to a maximum step of 75 mm— see Figure S6.6.



S6.9 Tolerances

- S6.9.1 Tolerances for bituminous materials permitted in A2 for the reinstatement of flexible and composite roads must be in accordance with the requirements of A2.
- S6.9.2 Tolerances for all other bituminous materials must be by agreement.

S7 Rigid and modular roads

S7.1 Reinstatement methods

General

- S7.1.1 When the total thickness of any bituminous overlay is 100 mm or more, it must be reinstated as a composite road in accordance with S6.
- S7.1.2 Some road constructions incorporating special design philosophies are outside the scope of this Code and reference should be made to NG 7.1.
- S7.1.3 The undertaker must carry out the reinstatement in accordance with one of the following methods and should endeavour to achieve the greatest degree of immediate permanent reinstatement. Reinstatement methods are listed in Table A2.10.
- S7.1.4 Permitted materials and layer thickness are specified in A1, A2, A5, A6, A9, A10 and A12.
- S7.1.5 Where the authority knows of any site with aggressive ground conditions it should advise undertakers in advance of the works so that appropriate measures may be taken.
- S7.1.6 Micro trenching in rigid and modular roads requires approval via A9 (materials and technology).

Method A – All permanent reinstatement

- S7.1.7 The excavation and concrete road slab must be reinstated to a permanent standard at the first visit. The bituminous overlay must not be laid until the cured road slab has achieved a compressive strength of $\geq 25 \text{ N/mm}^2$.

Method B – Permanent binder course reinstatement

- S7.1.8 Not applicable

Method C – Permanent base reinstatement

- S7.1.9 Not applicable

Method D – Permanent sub-base reinstatement

- S7.1.10 The backfill and sub-base must be reinstated to a permanent standard at the first visit.
- S7.1.11 In the interim period, the concrete road slab and overlay (if existing) can only be reinstated with a bound material. The interim surfacing must be a bound material to a thickness of 100 mm or 50 mm as shown in Figures A5.1 to A5.3.

S7.1.12 On the second visit, all interim materials must be removed to the top of the sub-base and a permanent concrete road slab reinstated. The road slab must be in accordance with S7.3. Any overlay may be reinstated to an interim standard in accordance with the relevant requirements of S6.1.9 to S6.1.11.

S7.1.13 At a later date, any interim overlay must be removed to the top of the concrete road slab and a permanent overlay must be reinstated.

Method E – Permanent reinstatement incorporating interim surface overlay

S7.1.14 Any bituminous surface overlay may be reinstated to an interim standard in accordance with the relevant requirements of S6.1.9 to S6.1.11.

S7.1.15 At a later date, any interim bituminous overlay must be removed to the top of the concrete road slab and a permanent bituminous overlay reinstated.

Alternative reinstatement materials

S7.1.16 ARMs may be used on rigid roads in accordance with A9.

S7.2 Sub-base reinstatement

General

S7.2.1 In a rigid road, the sub-base is deemed to be any layer of imported granular or HBM immediately below the base of the concrete road slab. Where such a sub-base exists, a similar or equivalent material must be laid to match the existing thickness subject to a minimum thickness of 150 mm.

S7.2.2 Permitted options as shown in A5 are subject to the following exceptions:

Small openings and narrow trenches

S7.2.3 A CBGM base may also be used as sub-base of 150 mm thickness in small openings and narrow trenches regardless of whether the existing sub-base is cement bound.

S7.3 Concrete road slab reinstatement

General

S7.3.1 Permitted options, as shown in A5, are subject to the following conditions:

Concrete specification

S7.3.2 Concrete road slabs must be reinstated with C32/40 concrete mixed in accordance with MCHW Clause 1001 and using an air entrainment admixture in the top 40 mm (at least) of the road slab. Exceptionally, where agreed, a concrete road slab may be reinstated with an alternative material to suit site conditions, e.g. a high early strength mix may be agreed to allow an earlier re-opening of a heavily trafficked road.

S7.3.3 Where concrete is mixed off site, Quality Assurance certificates detailing the specifications against which the concrete has been ordered and

supplied must be obtained by the undertaker for confirmation of material quality. Where possible, the concrete should be obtained from a plant that holds a Quality Assurance certificate.

- S7.3.4 In the case of small openings, a site-batched equivalent to C32/40 concrete detailed in S7.3.2 may be used.

Considerations related to pavement details

- S7.3.5 Information on the slab type and its condition, joint spacing and the presence of any other features near the proposed excavation should be requested from the authority by the undertaker. If this information is not made available, then an inspection survey commissioned by agreement may be carried out.

Joints

- S7.3.6 All expansion, contraction and warping joints removed or damaged during excavation must be replaced or reconstructed to a similar design, using equivalent materials at the time of permanent reinstatement.

Membranes

- S7.3.7 Any existing slip membrane must be reinstated beneath the road slab. A curing membrane must be used above the road slab.
- S7.3.8 Impermeable polythene or similar sheeting may be used for the slip and curing membranes.
- S7.3.9 Sprayed plastic film can be used as a curing membrane by agreement.

Texture depth

- S7.3.10 For small openings, narrow trenches and other openings less than 1 m wide, reference must be made to S2.6.1(2) and Table S2.5 and Table S2.6.
- S7.3.11 For all other excavations the authority must be consulted and a method agreed. The finished surface must comply with Table S2.5 and Table S2.6.

Opening to traffic

- S7.3.12 The cured road slab may be opened to traffic as soon as a compressive strength of 25 N/mm² has been achieved. The compressive strength may be measured on samples cured under conditions representative of the site conditions.

Damage

- S7.3.13 Corner and edge cracking and joint damage within the trench area must be repaired as a part of the reinstatement works.

S7.4 Large diameter cores

S7.4.1 Use of large diameter cores as an excavation and reinstatement technique is permitted in unreinforced rigid roads with the following conditions:

- 1) Large diameter cores cannot be taken within 300 mm of concrete slab corners or edges. This is to protect the integrity of the concrete pavement.
- 2) Where the technique is appropriate, it must be carried out in accordance with S6.7. To match the adjoining carriageway, between 100 mm to 150 mm of the sub-base may be removed.

S7.4.2 Large diameter cores may be used as an excavation method in continuously reinforced rigid roads. Trimming for reinstatement of the reinforcement may be required in accordance with S7.6. Re-using the excavated core is not permitted where there is a requirement to install connecting bars or lapped reinforcement.

S7.5 Edge support and preparation

S7.5.1 The edges of all excavations in rigid roads except large diameter cores (see S7.4) must comply with:

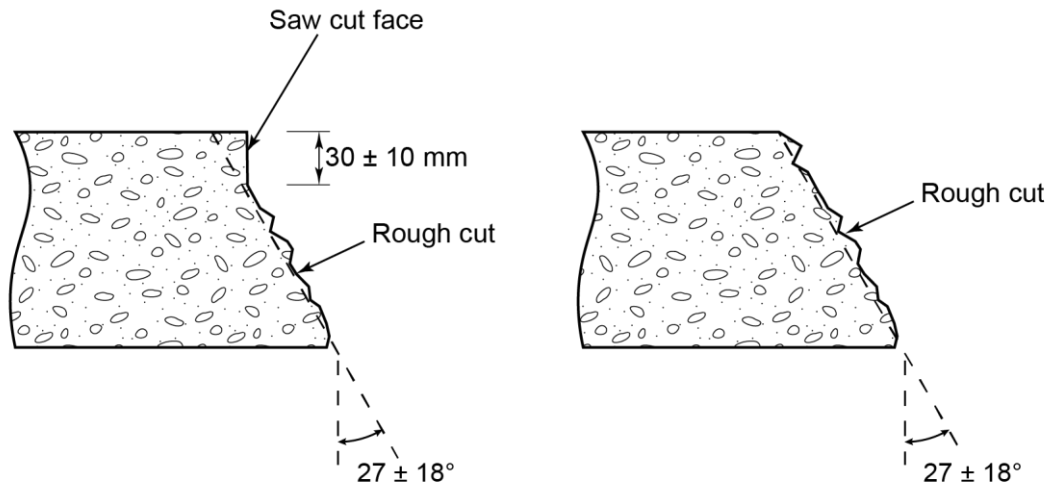
- 1) The use of edge taper support is only permitted in road categories 3 and 4. It may be used in road category 2 by agreement with the authority. If this method is used, S7.5.2 and S7.5.3 must be followed.
- 2) For road categories 0 and 1, dowel bars must be used as per S7.5.5 to S7.5.11. For road category 2, dowels must be used unless otherwise agreed with the authority.

Edge taper support

S7.5.2 Where the top of the slab is the running surface, the excavation must be delineated by pavement sawing to a depth of 30 mm \pm 10 mm. The remainder of the exposed faces should be rough cut, at an angle of 27° \pm 18° to the vertical; see Figure S7.1

S7.5.3 In all other cases, the exposed faces should be rough cut, at an angle of 27° \pm 18° to the vertical. Delineation by pavement saw, to a depth of 30 mm \pm 10 mm, may also be applied.

Figure S7.1 Slab edge taper options



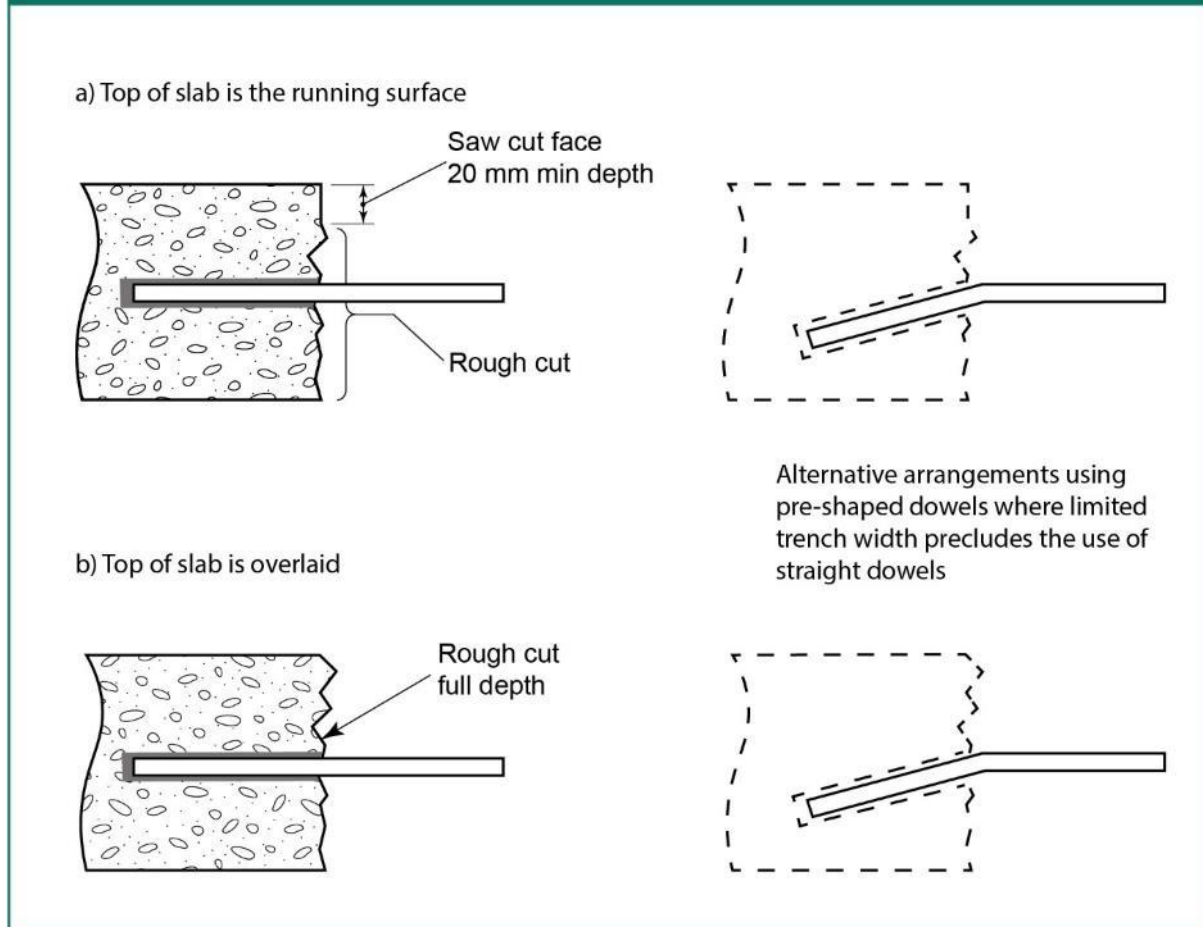
S7.5.4 The edge of the excavation must not be located within 300 mm of a kerb, ironwork, transverse or longitudinal joints or another reinstatement unless the trim-line and surface reinstatement can be extended up to the feature in question.

Dowel bar support

S7.5.5 Where the top of the slab is the running surface, the excavation must be delineated by pavement sawing to a minimum depth of 20 mm. Any unsawn section of the slab may be left rough-cut as long as it presents an approximately vertical surface - see Figure S7.2 (a). For overlaid slabs, the edges should be prepared as detailed in Figure S7.2 (b).

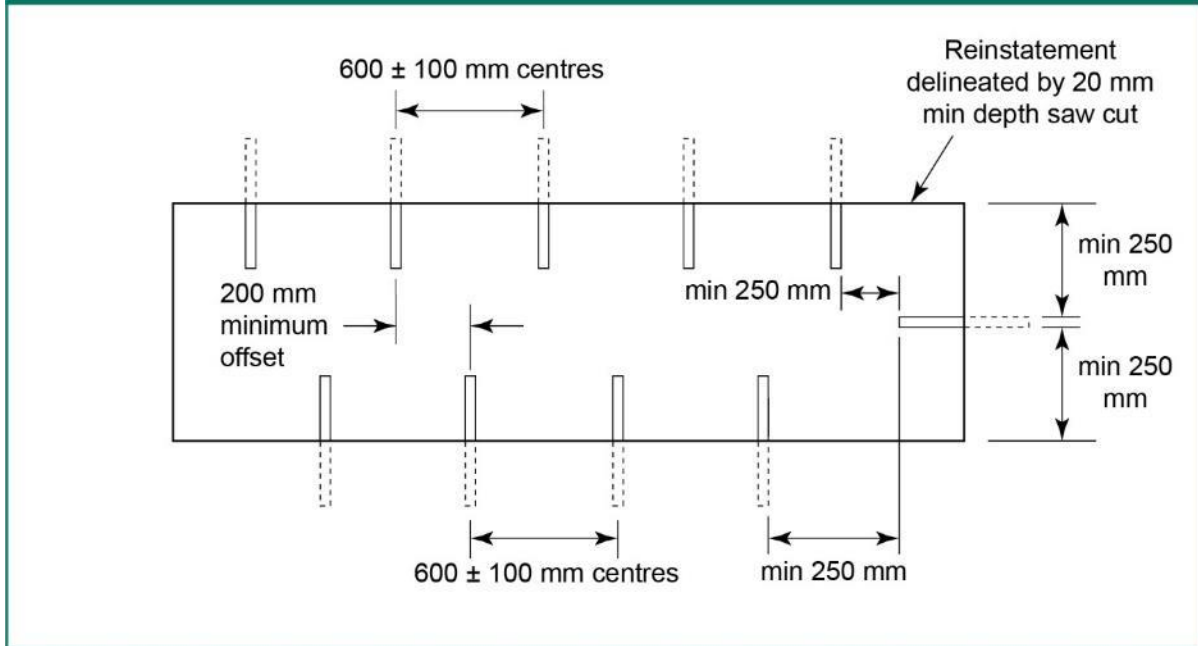
S7.5.6 In narrow trenches and small openings (S1.5.3 and S1.5.4) the cut section of concrete may need to be widened to accommodate dowel bar installation or the holes may be drilled at an angle to allow the use of pre-shaped (angled) dowel bars. They must be drilled along the centreline of the exposed faces, to provide a sliding fit for 20 mm or 25 mm diameter steel dowel bars.

Figure S7.2 Edge options



- S7.5.7** In other openings or deep openings (S1.5.5 and S1.5.6 respectively), a row of horizontal holes must be drilled along the centreline of the exposed faces to provide a sliding fit for 20 mm or 25 mm diameter steel dowel bars as shown in Figure S7.3.
- S7.5.8** The holes must be drilled at $600 \text{ mm} \pm 100 \text{ mm}$ centres, with the holes along one face offset, relative to the opposite face by at least 200 mm when viewed from above; see Figure S7.3. The nominal hole depth must be equal to 50% of the dowel bar length $\pm 50 \text{ mm}$.
- S7.5.9** The edge of the excavation must not be located within half of the dowel bar length plus 300 mm of a kerb, ironwork, transverse or longitudinal joints or another reinstatement unless the trim-line and surface reinstatement can be extended up to the feature in question, i.e. if 300 mm dowel bars are used, the minimum distance between the edge of the excavation and a kerb, ironwork, transverse or longitudinal joints or another reinstatement should be 450 mm.
- S7.5.10** Dowel bars must be located at a minimum distance of 250 mm from the edge of the excavation, see Figure S7.3.

Figure S7.3 Dowel bar arrangement - plan view



S7.5.11 The minimum dowel bar length is equal to the width of the reinstatement less 50 mm with a maximum dowel bar length of 400 mm. The first step in installing dowel bars is to place grout (cementitious or epoxy) into the back of each hole. The end of the bar that extends into the utility cut area should have a bond breaker applied to it to prevent bonding with the patch material. This bond breaker may be applied by the manufacturer or may be field-applied. Dowel bars must be clean, free of flaking rust, and epoxy-coated (or have equivalent anti-corrosion treatment) before installation.

Edge preparation

- S7.5.12** Where necessary, the edges of the reinstatement must be trimmed over part or all of slab depth to comply with the following requirements:
- 1) The edge regularity must comply with the requirements of S6.8.6.
 - 2) Any undercutting must comply with the requirements of S6.8.10.
 - 3) Where the adjacent road slab has cracked as a result of the excavation operation, the damaged area of the slab must be removed and included within the area to be reinstated.
 - 4) Where, after trimming, the excavation extends to within 300 mm of a slab edge, a joint, ironwork or another reinstatement, the relevant area of the slab must be removed and included within the area to be reinstated.
 - 5) All edges must be cleaned and wetted before placing concrete.

S7.6 Reinforcement

No reinforcement in existing concrete

S7.6.1 If the existing concrete is unreinforced and the trench is more than 1.5 times longer than it is wide, or where the reinstatement covers more than

one slab, the reinstated concrete must be reinforced to mitigate early life non-structural cracking.

S7.6.2 In this case, the reinforcement must be placed in the upper part of the slab (with a minimum cover of 60 mm).

S7.6.3 In all other cases, when the existing concrete has no reinforcement, no reinforcement is needed.

Reinforcement in existing concrete

S7.6.4 If the existing concrete is reinforced, there is no need to replicate the existing reinforcement if:

- 1) the only reinforcement in the existing reinforced slab is within the upper 90 mm (measured to the top of the reinforcement from the top of the slab), and
- 2) the reinforcement is a mesh with a diameter of 12 mm or less and the distance between bar centres is 210 mm or less; and
- 3) the trench length to width ratio is below 3:2, i.e. length is greater than 1.5 times the width.

S7.6.5 In all other cases, when the existing concrete is reinforced, the reinforcement within the excavation must be measured and recorded by the undertaker in the relevant street works notice or permit and the reinforcement in the reinstatement must replicate the original construction.

Tie ins

S7.6.6 No connecting bars or lapped reinforcement are required where:

- 1) the only reinforcement in the existing reinforced slab is within the upper 90 mm (measured to the top of the reinforcement from the top of the slab), and
- 2) the reinforcement is a mesh with a diameter of 12 mm or less and the distance between bar centres is 210 mm or less.

S7.6.7 All other reinforcement must be provided in accordance with the following requirements:

- 1) The new reinforcement must be lapped and connected to the existing reinforcement. Reliable methods of connecting the bars include tied splices, mechanical fastening and welded splices.
- 2) A minimum of 150 mm of the existing reinforcement must be exposed to allow adequate connection of the new reinforcement.
- 3) Where 150 mm of the exposed reinforcement cannot be preserved during the excavation, the concrete road slab must be trimmed as necessary to expose additional reinforcement. This additional trimming does not supersede any requirement to provide dowel bars.
- 4) Where additional trimming extends beyond 300 mm and the reinforcement cannot be preserved, then the new reinforcement is not required to be connected or lapped.
- 5) For narrow trenches and small openings, the cut section of concrete may need to be widened to accommodate tie ins.

S7.7 Overlays

General

- S7.7.1 Where the surface of the concrete road slab or the modular surface layer is overlaid with a bituminous material or surface treatment, a matching thickness of a similar or equivalent material must be laid.
- S7.7.2 Wherever practicable, the required surface course thickness should be maintained by adjustment of the binder course thickness. The surface course and binder course materials must not be laid to a thickness less than that required by A2 or A3 for the nominal size of each material laid.
- S7.7.3 Where the surface of the concrete road slab or modular surface has had a surface treatment including overlay, an equivalent surface treatment or overlay must be applied.

Surface reinstatement

- S7.7.4 Permitted options are shown in A4 and A5, subject to the following exceptions:
- 1) Edge preparation must be carried out in accordance with S6.8, except that the existing edge of the overlay must be trimmed to a distance equal to the nominal thickness of the surface course or 40 mm, whichever is the greater.
 - 2) Surface reinstatement must be carried out in accordance with the requirements of S6.4 or S6.5, whichever is applicable.

S7.8 Modular roads

- S7.8.1 Types 0, 1 and 2 modular roads are not included in this Code and reinstatement designs must be in accordance with BS 7533-3 and BS 6717.
- S7.8.2 The undertaker must carry out the reinstatement of Types 3 and 4 modular roads in accordance with one of the following methods and should endeavour to achieve greatest degree of immediate permanent reinstatement.
- S7.8.3 Permitted materials and layer thickness are specified in A1, A2, A6, A9, A10 and A12, subject to the following requirements.
- S7.8.4 Where modules of natural stone material are present in trafficked roads, refer to A12.

Method A – All permanent reinstatement

- S7.8.5 The backfill, sub-base (if present), bedding and modular surface layer must be reinstated to a permanent standard at the first visit.

Method B – Permanent sub-base reinstatement

- S7.8.6 The backfill and sub-base must be reinstated to a permanent standard at the first visit, together with an interim granular base and interim bituminous surface course, as per S6.1.12 to S6.1.14.

- S7.8.7 On the second visit, the interim reinstatement must be removed to the top of the sub-base and a permanent base, bedding and modular surface layer reinstated.

Sub-base reinstatement

- S7.8.8 Permitted options are shown in A6, subject to the requirements of S6.2.
- S7.8.9 The sub-base must be reinstated to match the existing materials and thicknesses, or its structural equivalent.

Base reinstatement

- S7.8.10 Permitted options are shown in A6, subject to the requirements of S6.3.
- S7.8.11 The base must be reinstated to match the existing materials and thicknesses, or its structural equivalent.

Surface reinstatement

- S7.8.12 The modular surface layer must be reinstated in accordance with A6 and A12. The requirements and recommendations for replacement modules are given in A12.

Alternative reinstatement materials

- S7.8.13 ARMs may be used in modular roads in accordance with A9.

S7.9 Tolerances

- S7.9.1 All performance requirements and tolerances permitted in the reinstatement of rigid and modular roads must be in accordance with the requirements of S2 and A2.

S8 Footways, footpaths and cycle tracks

S8.1 Reinstatement methods

General

- S8.1.1 The undertaker must carry out reinstatement in accordance with one of the following methods and should endeavour to achieve the greatest degree of immediate permanent reinstatement. Reinstatement methods are listed in Table A2.10.
- S8.1.2 In the event of prior notification by the authority, where local custom and practice is to surface footways, footpaths and cycle tracks with aggregates of a certain colour or minimum PSV, the undertaker must provide equivalent aggregate at the time of permanent reinstatement, subject to the requirements of S2.6.1.
- S8.1.3 Permitted materials and layer thickness are specified in A1, A2, A7, A9, A10 and A12. In all flexible reinstatements, the surface course material may also be used at binder course level, as shown in Figure A7.1.
- S8.1.4 Cycle tracks that are part of the carriageway must be reinstated to carriageway standards.
- S8.1.5 S6.5 must be followed for small openings and narrow trenches. For micro trenching, large diameter cores and work around ironwork, S6.6, S6.7 and S11.5 must be followed, respectively.

Method A – All permanent reinstatement

- S8.1.6 The excavation must be reinstated to a permanent standard at the first visit.

Method B – Permanent binder course reinstatement

- S8.1.7 In flexible structures, the backfill, sub-base and binder course must be reinstated to permanent standard at the first visit.
- S8.1.8 The permanent binder course material, or an alternative interim material, must be extended to the running surface with or without a thin separating medium at the binder course/surface course interface (as appropriate). The alternative interim material may be a bituminous mixture.
- S8.1.9 On the second visit, all interim surfacing materials must be removed to the top of the binder course and an appropriate permanent surface course laid.

- S8.1.10 Where a sand separation layer is present, before reinstating the permanent surface course, the sand must be removed, the surface brushed clean and a bond coat applied.

Method C – Permanent base reinstatement

Not applicable

Method D – Permanent sub-base reinstatement

- S8.1.11 The backfill and sub-base must be reinstated to a permanent standard at the first visit with an interim surfacing.
- S8.1.12 For flexible or rigid structures, the interim surface course and some or all of the interim binder course may be a bituminous mixture. The lower portion of the interim binder course may be an unbound granular material.
- S8.1.13 For modular structures, the interim surfacing may be a bituminous mixture, paving modules or any combination thereof.
- S8.1.14 On the second visit, all interim surfacing materials must be removed to the top of the sub-base and an appropriate permanent surfacing must be laid.

Method E – Permanent reinstatement incorporating interim surface overlay

Not applicable

Alternative reinstatement materials

- S8.1.15 ARMs may be used in flexible and composite footways, footpaths and cycle tracks in accordance with A9.

S8.2 Sub-base reinstatement

General

- S8.2.1 Flexible and composite footways, footpaths and cycle tracks must be reinstated with the permitted options shown in Figures A7.1 and A7.2 respectively, subject to the exceptions described in S8.2.3 to S8.2.6.
- S8.2.2 Rigid footways, footpaths and cycle tracks must be reinstated with the permitted options shown in Figure A7.3, subject to the exceptions described in S8.2.3 to S8.2.6.

Small openings and narrow trenches

- S8.2.3 In small openings and narrow trenches, the following options are permitted regardless of whether the existing sub-base is a bound material:
- 1) An HBM sub-base of 100 mm minimum thickness; or
 - 2) A 50/20 HRABC or 20 mm DBC material of minimum 40 mm thickness, laid in place of the granular sub-base; or
 - 3) Three equal layers of 15/10 HRASC, 6 mm DSC or 6 mm SMA material laid to a total thickness of 100 mm, as a combined sub-base, binder course and surface course.

Alternative reinstatement materials (ARMs)

- S8.2.4 Alternative reinstatement materials may be laid at sub-base level in accordance with A9.

Reinstatements adjacent to roads

- S8.2.5 Where road construction layers, foundation platforms, structural courses, kerb beams or backing providing the edge support to the road structure are found to extend below an adjacent footway, footpath, cycle track or verge, any reinstatement must take account of such provisions.
- S8.2.6 In such cases, the sub-structure of the footway, footpath, cycle track or verge must be reinstated to match the existing layer thickness with similar or equivalent materials.

S8.3 Surface reinstatement

General

- S8.3.1 Surface reinstatement options for flexible, composite and rigid footways, footpaths and cycle tracks are shown in A7, subject to the following exceptions:

High duty and high amenity areas

- S8.3.2 The authority must register all high duty/amenity footways, footpaths or cycle tracks and identify a source of reinstatement materials.
- S8.3.3 The undertaker should reinstate all registered high duty/amenity footways, footpaths or cycle tracks with matching materials from the identified source.
- S8.3.4 If the proposed material/product is not appropriate, the authority must work with the undertaker to locate an alternative source.
- S8.3.5 If the material is not identified by the authority, the undertaker should use best endeavours to match the existing surfacing material.
- S8.3.6 Where aggregates of a distinctive colour are encountered and local custom and practice has been to complete all previous surfacing in a similarly matching material, the reinstatement must be in accordance with S6.4.14.

Areas surfaced with bituminous materials

- S8.3.7 Footways, footpaths or cycle tracks surfaced with bituminous materials must be reinstated with the approved materials specified in A2 (see Figure A2.5 for options permitted).
- S8.3.8 Footways, footpaths or cycle tracks surfaced with HRA must be reinstated with HRA.
- S8.3.9 Footways, footpaths or cycle tracks surfaced with SMA must be reinstated with either SMA surface course or, by agreement, with HRA.
- S8.3.10 Footways, footpaths or cycle tracks surfaced with AC must be reinstated with either AC or HRA.

- S8.3.11 Where the authority has a policy of using a specific type of asphalt surfacing on footways (i.e. the material specification is not wholly contained within the options given in A2), the undertaker must take all reasonable measures to reinstate excavations with that material unless otherwise agreed with the authority.
- S8.3.12 The authority, when requested, should provide any details they have on suitable suppliers and specifications. Where no practicable source of supply can be found, the reinstatement must be carried out in accordance with S8.3.7.

Areas constructed in concrete

- S8.3.13 Concrete footways, footpaths or cycle tracks must be reinstated with C25/30 minimum strength concrete, as per S7.3.2 to S7.3.4, to match the existing thickness (see Figure A7.3). For small openings, site-batched concrete of equivalent strength may be used.
- S8.3.14 Where the authority knows of any site where air-entrained concrete has been used, it should advise undertakers in advance of the works.
- S8.3.15 Where the existing concrete has been air-entrained, air-entrained concrete to MCHW Clause 1001 must be used. Air-entrained concrete may be used elsewhere at the discretion of the undertaker.

Modular footways, footpaths and cycle tracks

- S8.3.16 Modular footways, footpaths and cycle tracks must be reinstated in accordance with the permitted materials and layer thickness specified in Figure A7.4.
- S8.3.17 The modular surface layer must be reinstated in accordance with A12. The requirements and recommendations for the provision of replacement modules are shown in A12.
- S8.3.18 For the reinstatement of natural stone modular surfaces, the following applies:
- 1) Natural stone modules within the area to be excavated must be removed and stored by the undertaker for re-use.
 - 2) Modules must be reinstated in accordance with A12.
 - 3) Where the authority has a policy that seeks to re-use existing modules that are damaged, the parts or fragments must be removed and stored by the undertaker for re-use. The undertaker must notify the authority and the method of reinstatement for these materials must be agreed, including any limitation on the size of the fragments.
 - 4) Where it has been agreed that damaged modules are to be re-used as part of the permanent reinstatement, the surface profile at the end of the guarantee period is not required to be superior to that existing at the time of excavation.
 - 5) The undertaker must use best endeavours to match existing profiles and meet the tolerances specified in S2, subject to the limitations outlined in A12.

Special materials

- S8.3.19 Other specialist surfacing materials must be reinstated in accordance with S6.4.15.
- S8.3.20 In high duty footways, footpaths and cycle tracks where local custom and practice has been to complete previous surface restoration of excavations with overbanding or other coating of a certain minimum skid resistance value, the undertaker must provide a similar minimum skid resistance value for the material used to overband reinstatement edges.

S8.4 Micro trenching

- S8.4.1 Micro trenching in flexible footways, footpaths and cycle tracks is covered in S6.6. Micro trenching in rigid and modular footways, footpaths and cycle tracks requires approval via A9 (materials and technology).

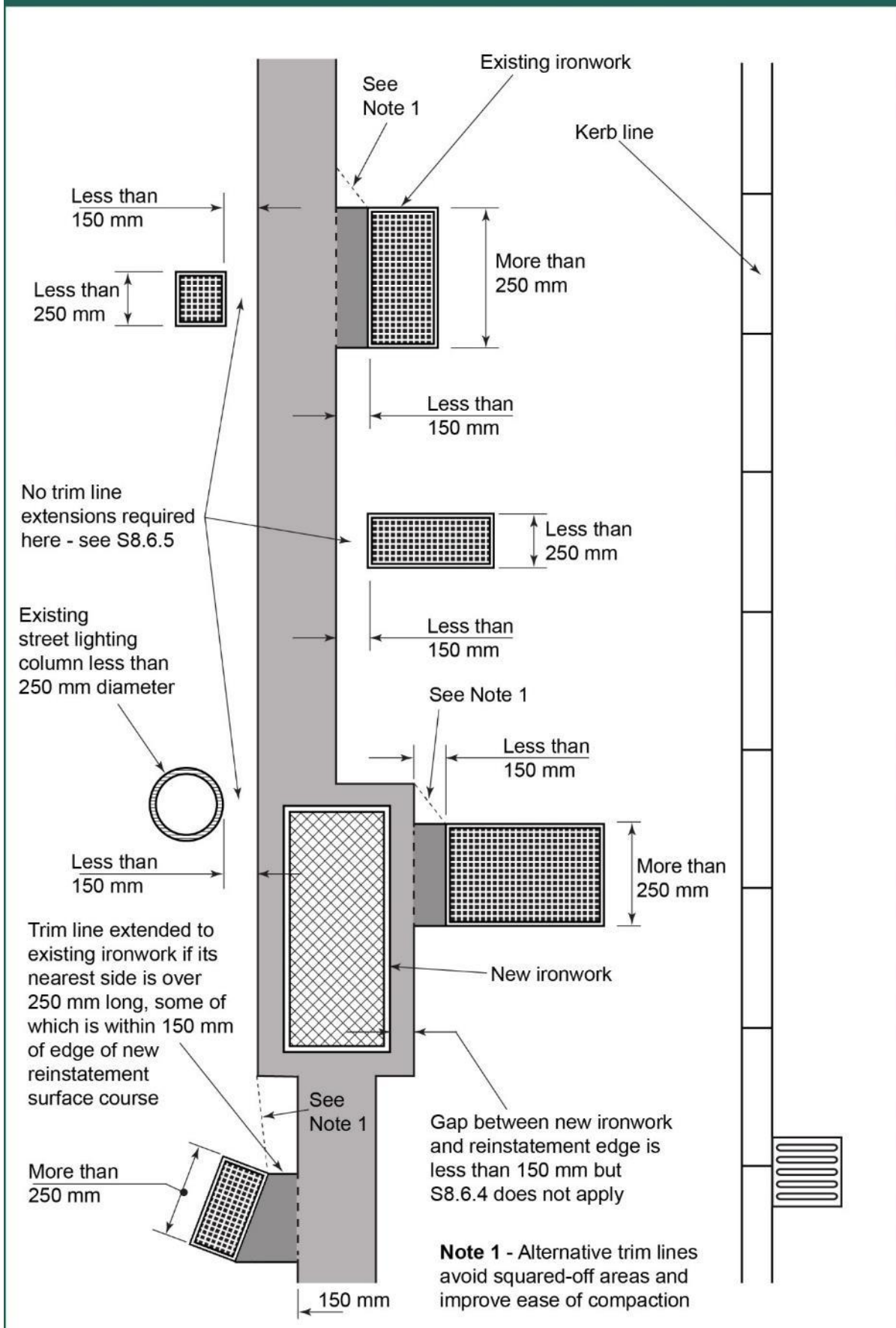
S8.5 Large diameter cores

- S8.5.1 Large diameter coring is permitted in footways, footpath and cycles tracks. This must be in accordance with S6.7 except that in footways, footpaths and cycle tracks, the minimum bound layer/slab depth is 60 mm (not 100 mm as per S6.7).

S8.6 Edge requirements

- S8.6.1 For all footways, footpaths and cycle tracks, the base and edge preparation must comply with S6.8.
- S8.6.2 For all concrete footways, footpaths and cycle tracks, the treatment of any cracking must comply with the requirements of S7.5.12 (3).
- S8.6.3 For all footways, footpaths and cycle tracks, where trim-lines for the reinstatement edges are within 150 mm of an edge, kerb, ironwork or other reinstatements, the trim-lines must be extended to the interface of the edge, kerb etc. This additional reinstatement may be confined to the surface course provided lower courses have not been damaged. In this case, the surface thickness must match the existing. If the lower layers have been damaged, the trim line must include all layers and these must be fully reinstated in accordance with this Code. See Figure S8.1.
- S8.6.4 Fixed features in the footway such as sign posts, lamp columns, stop-cock valve boxes, etc. that are less than 250 mm diameter or 250 mm wide on the side facing the reinstatement are exempt from the trim-line extension.

Figure S8.1 Edge requirements and trim lines in footways



S8.7 Vehicular trafficking

Commercial access

- S8.7.1 Where a recognised route for commercial vehicles crosses a footway, footpath or cycle track, the relevant area of the crossing is deemed to be a Type 4 road.
- S8.7.2 Reinstatement of the crossing area must comply with the relevant requirements of S6 or S7, as appropriate.
- S8.7.3 Where a special construction has been incorporated in the original design to cater for expected traffic greater than the Type 4 limiting capacity, the undertaker should consult the authority.

Domestic access

- S8.7.4 Where a recognised domestic vehicle route or occasional emergency service vehicle access route crosses a footway, footpath or cycle track, the existing structure may include thicker layers, higher quality materials or other strengthening measures.
- S8.7.5 Reinstatement of the crossing area must match the existing layer thickness using similar or equivalent materials.

Other trafficking

- S8.7.6 Where a footway, footpath, cycle track or specified pedestrian area is subjected to regular vehicle overrunning or parking, the existing structure may include thicker layers, higher quality materials or other strengthening measures.
- S8.7.7 Reinstatement of such areas must match the existing layer thickness using similar or equivalent materials.

S8.8 Tolerances

- S8.8.1 Performance requirements and tolerances permitted in the reinstatement of footways, footpaths and cycle tracks must be in accordance with the requirements of S2 and A2.

S9 Verges and unmade ground

S9.1 General

S9.1.1 Backfill materials must comply with the requirements of S5.

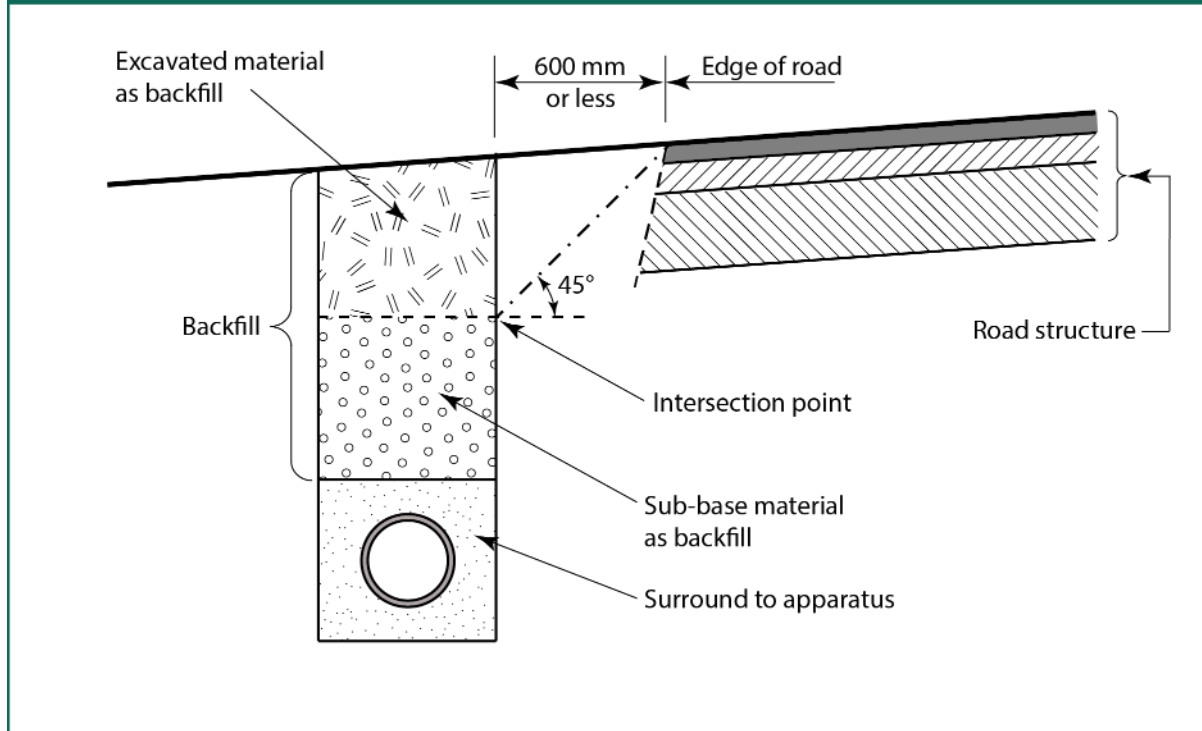
- 1) Topsoil within 200 mm of the surface of the verge must be stored and re-used. Where insufficient topsoil is available from the excavation, imported topsoil may be used to a depth of 100 mm or to match the existing depth, whichever is the lesser.
- 2) Care must be taken to ensure that imported topsoil is not contaminated with non-organic material or noxious weeds.
- 3) The re-use of excavated materials as backfill in verges and unmade ground is to be encouraged as part of a policy of environmentally sustainable construction.
- 4) Where invasive plant species are identified within the excavated materials, these materials must not be re-used in the reinstatement. Appropriate advice may be sought from the authority or DEFRA as to the means of permissible disposal.

S9.2 Adjacent road structures

S9.2.1 Where road construction layers (including any structural courses, foundations, kerbs or backing that provide edge support to road structures) extend below adjacent verges or unmade ground, any reinstatement must take account of such provisions. The reinstatement of such areas must match the existing layer thicknesses, with similar or equivalent materials.

S9.2.2 Where there is no edge support, if an excavation comes within 600 mm of the edge of a road and the backfill extends below the intersection point shown in Figure S9.1, sub-base material must be used for backfill below that point. The intersection point is where a 45° line extending downwards from the edge of the road surface intersects the side of the trench nearest the road. Above this point, excavated material can be used as backfill.

Figure S9.1 Verge reinstatement adjacent to unsupported road edge



S9.3 Cultivated areas

S9.3.1 Unless otherwise agreed, cultivated areas containing shrubs, plants or bulbs must be reinstated using the same or similar species. Thereafter, a reasonable growth must be established within the following 12 months. Where the authority knows of special features in verges (e.g. orchid sites etc.) it should inform the undertaker to agree the best means of conserving those features.

S9.4 Grassed areas

S9.4.1 Grassed areas must be reinstated using the original turf, replacement turf or an equivalent seed, depending on weather and growing season. In all cases, a reasonable growth must be established within the following 12 months.

S9.4.2 Where grassed areas have been mown, the reinstated surface must be demonstrably free from stones greater than 20 mm nominal size. All other debris arising from the works must be removed from the site. It should be recognised that stones in grassed areas tend to migrate to the surface over a period of time and this should not lead to repeated intervention.

S9.5 Verges, ditches and drainage courses

S9.5.1 Verges, ditches and drainage courses must be restored to their original profile unless otherwise agreed.

S10 Compaction requirements

S10.1 Introduction

- S10.1.1 All compaction equipment covered by this Code must be checked, adjusted, maintained and operated in accordance with working practices, maintenance schedules, operating procedures and vibration frequencies recommended by the equipment manufacturer. Where available, relevant records must be provided to the authority on request within a reasonable period of time.
- S10.1.2 If available, records can demonstrate to the authority that the undertaker is using calibrated equipment. If data is not available, the authority may monitor more closely to check on compaction.
- S10.1.3 All equipment and operating procedures used for compacting reinstatement materials laid above the surround to apparatus must comply with the following requirements:

S10.2 Compaction of materials

- S10.2.1 For all materials, compaction must be carried out in accordance with the requirements of A2 or A8 immediately after the material has been placed.

Unbound granular and cohesive materials

- S10.2.2 All Class A Graded Granular Materials, Class B Granular Materials and Class C Cohesive/Granular Materials must be compacted in accordance with the relevant requirements of A8.
- S10.2.3 All Class D Cohesive Materials must be compacted in accordance with the relevant requirements and restrictions of A8.
- S10.2.4 For restricted areas, compaction must be in accordance with the restricted areas provisions of A8.

Alternative reinstatement materials (ARMs)

- S10.2.5 Certain structural materials for reinstatements (SMRs) and treated materials for fill (TMFs) may not require the full compaction specified in A8 and may be damaged if over-compacted. Such materials should be placed and compacted in accordance with the manufacturer's recommendations with due regard to the requirements of A9.
- S10.2.6 FCRs must not be compacted or tamped unless specifically required by the manufacturer. Thereafter, such FCR materials must be placed and compacted in accordance with the manufacturer's recommendations with due regard to the requirements in A2.5.3 to A2.5.18.

Bituminous materials

S10.2.7 All bituminous materials permitted by A2, except those covered in A2.5, must be laid and compacted in accordance with the relevant requirements of A2 and Tables A2.5, A2.7 and A2.8, and A8.3.

S10.2.8 The in-situ air voids content for all bituminous materials as permitted in A2 must comply with the requirements shown in Table S10.1. The in-situ air voids content must be calculated as the average from all results obtained.

- 1) Cores must be extracted as per BS EN 12697-27.
- 2) The maximum density must be determined in accordance with BS EN 12697-5 Procedure A, in water.
- 3) The bulk density must be determined in accordance with BS EN 12697-6 Procedure C sealed specimen.
 - a) If two or more cores are retrieved from a reinstatement, wax sealing is the preferred method.
 - b) If only one core is retrieved from a reinstatement, alternative sealing methods permitted in BS EN 12697-6 Procedure C such as using self-adhesive aluminium foil or vacuumed plastic wrap may be used.
- 4) The maximum density and core bulk density must be used to determine air void content in accordance with BS EN 12697-8.

Table S10.1 In-situ air voids content requirements

Bituminous materials	Permitted air voids			
	Carriageways		Footways, Footpaths and Cycle tracks	
	Max %	Min %	Max %	Min %
AC6 dense surface course	NP	NP	13	2
AC10 close surface course	11	2*	11	2*
HRA surface course	7	2	10	2
SMA surface course	8	2	10	2
AC binder course	10	2*	12	2*
HRA binder course	9	2	12	2
SMA binder course	6	2	NP	NP
Permanent cold-lay surfacing materials (PCSM)	10	2	13	2
Any other bituminous materials within the specification	No air-voids limits apply. Guidance on compaction contained in NGA8.3			
NP = not permitted				
* If the binder content is increased as per A2.3.5 and A2.3.6 the minimum air voids is 0.5%.				

- S10.2.9 All surface course materials used at binder course level must comply with the in-situ air voids content requirement for the relevant surface course material.
- S10.2.10 To determine the in-situ air void content core samples must be taken at a rate of 1 per 6 m² or part thereof. However, the undertaker should be given the opportunity to accept the results or to agree to further coring if they suspect that the results reflect localised areas of non-compliance. The average void content must be calculated for each reinstatement covered by a single notice. All core samples must be 95 mm minimum diameter with no part of any core being within 100 mm of any surface apparatus within the reinstatement. Where there is a potential to encounter the edge of the frame or apparatus, this distance should be increased accordingly.
- S10.2.11 Unless agreed otherwise, all air voids testing must be carried out by a laboratory holding current UKAS accreditation for the specified test methods.
- S10.2.12 Where core samples are recovered from a location overlaying an unbound substrate, trimming the bottom of a core sample is only permitted where it exceeds the specified length. Trimming the upper part of a core sample is not permitted. In any case, the length of core samples subjected to testing must comply with this Code.
- S10.2.13 Where prevailing weather conditions or other site circumstances are considered likely to hamper the successful laying and compaction of any surfacing materials and the achievement of the required in-situ air voids content, consideration should be given to deferring the permanent surface reinstatement and, if necessary, to an agreed extension of the interim reinstatement period.

Hydraulically bound materials, CBGM base and concrete

- S10.2.14 Pavement quality concrete, laid as the surface slab of road, footway, footpath or cycle track reinstatements, must be compacted using a proprietary vibrator, selected and operated in accordance with the manufacturer's recommendations. However, proprietary vibrators may be unsuitable for concrete sections less than 100 mm wide or less than 0.5 m² in area. In such cases, as a minimum requirement, all concrete must be thoroughly tamped by hand.
- S10.2.15 CBGM base must be compacted in accordance with the relevant requirements of A8.
- S10.2.16 Where the HBM is not CBGM base, it must be compacted in accordance with the requirements of A10.2.

Modular surfacing materials

- S10.2.17 Compaction equipment must be operated in accordance with the manufacturer's instructions.

S10.3 Equipment operation and restrictions

- S10.3.1 All compaction equipment must be used in accordance with the requirements of A8.
- S10.3.2 Additional guidance on compaction procedures is included in NG10.3.

S10.3.3 Alternative technologies (ATs) may be used in accordance with A9.

Hand rammers

S10.3.4 Except as permitted in S2.2.1, S6.5.3, S6.5.4, S10.2.5, S10.2.6, S10.2.14 and S11.5, hand rammers can only be used to assist the initial placement of material.

S10.3.5 For all materials, full compaction must be applied, in accordance with the relevant requirements of A8.

Mechanical pole tampers

S10.3.6 Mechanical pole tampers may be used for compaction around iron work in footpaths, footways and cycle tracks.

Percussive rammers

S10.3.7 Percussive rammers are permitted for compacting reinstatement materials in accordance with the following requirements:

- 1) The nominal mass must not be less than 10 kg.
- 2) The width of the foot must not exceed 200 mm.
- 3) The contact length of the foot must not exceed 200 mm.

Vibrotampers

S10.3.8 Vibrotampers are permitted for compacting reinstatement materials in accordance with the following requirements:

S10.3.9 *50 kg minimum nominal mass*

- 1) The width of the foot must not exceed 5 mm/kg of the nominal mass.
- 2) The contact length of the foot must not exceed 350 mm nor be less than 175 mm.
- 3) The foot contact area must not exceed 1000 mm²/kg of the nominal mass.
- 4) The mass of any extension leg must not exceed 10% of the nominal mass.

S10.3.10 *25 to 50 kg nominal mass – permitted in restricted areas only*

- 1) The width of the foot must not exceed 150 mm.
- 2) The contact length of the foot must not exceed 200 mm.

Vibrating rollers

S10.3.11 Vibrating rollers are permitted for compacting reinstatement materials in accordance with the following requirements:

S10.3.12 *Single-drum vibrating rollers*

- 1) Single drum vibrating rollers must include a mechanical means of applying vibration to the roll. Single-drum rollers without a specific vibration unit are considered to be single-drum deadweight rollers and are not permitted for reinstatement purposes.

- 2) The minimum permitted mass of a single-drum vibrating roller is 600 kg/m width.

S10.3.13 *Twin-drum vibrating rollers*

- 1) Twin-drum vibrating rollers must include two vibrating rolls. Twin-drum rollers in which only one roll vibrates are considered to be single-drum vibrating rollers.
- 2) The minimum permitted mass of a twin-drum vibrating roller is 600 kg/m width.

S10.3.14 *All vibrating rollers*

- 1) The mass per metre width of a vibrating roller must be calculated by dividing the total mass supported by the roll(s) by the total width of the roll(s).
- 2) A minimum mass of 600 kg/m width is required for vibrating rollers for compacting bituminous material. Where existing roads, footways, footpaths or cycle tracks could be marked or otherwise damaged by the use of 600 to 1000 kg/m vibrating rollers, the authority must notify the undertaker accordingly, whereupon the use of lower weight vibrating rollers must be agreed.

Vibrating plate compactors

- S10.3.15** Vibrating plate compactors of 1400 kg/m² minimum mass are permitted for compacting reinstatement materials.

Other compaction equipment

- S10.3.16** Other compaction equipment, including machine-mounted compactors and all other compaction devices not specifically referenced within A8, may be permitted for compacting reinstatement materials(see NG10).

S11 Ancillary activities

S11.1 Traffic signs, road markings, studs and verge markers

General

- S11.1.1 Before opening any works to traffic, all traffic signs, road markings, studs and verge markers removed during the works must be reinstated to a permanent or temporary standard. Temporary traffic signs, road markings, studs and verge markers are permitted for a maximum of 15 working days following completion of the permanent reinstatement.
- S11.1.2 All traffic signs, road markings, studs and verge markers removed during works must be reinstated at their original locations wherever possible. Where this is not possible, they must be permanently reinstated to a new layout in accordance with the Traffic Signs Manual and the Traffic Signs Regulations & General Directions.
- S11.1.3 Where the layout of existing traffic signs, road markings, studs or verge markers is not in accordance with the Traffic Signs Manual and the Traffic Signs Regulations & General Directions, and the authority notifies the undertaker before starting the works, the layout of all traffic signs, road markings, studs or verge markers to be reinstated following the works must be determined by agreement. In this event, if the authority provides new traffic signs, studs or verge markers to replace obsolete or previously damaged items removed during the works, the undertaker must install them as part of the permanent reinstatement of the works.

Traffic signs, studs and verge markers

- S11.1.4 Wherever possible, all traffic signs, studs and verge markers removed during the works must be reused on completion. Where the original items cannot be reused, they must be replaced using items of equivalent type, colour, performance and dimensions.

Road markings – General

- S11.1.5 Before permanent reinstatement, temporary road markings may be made using quick drying, durable paint, adhesive strip or like materials of similar colour and dimensions to the original markings.
- S11.1.6 Road markings removed during the works must be permanently reinstated using materials of equivalent colour and dimensions.
- S11.1.7 Except where otherwise specified by the authority, the retro-reflectivity and skid resistance of all yellow and white lines must comply with BS EN 1436, as follows:

1) Dry retro-reflectivity to Table 3:

Yellow – Class R0

White – Class R2

2) Wet skid resistance to Table 7:

Yellow – Class S1

White – Class S3

S11.1.8 Unless otherwise agreed by the authority, all white thermoplastic road markings must be treated with surface-applied glass beads to achieve the performance requirements in S11.1.7.

S11.1.9 Hot-applied thermoplastic road marking materials with synthetic resin binder must be laid to the following thickness:

1) Screed lines – 3.5 mm ± 1.5 mm

2) Sprayed yellow edge lines (No Waiting, etc.) – 0.8 mm minimum

3) Sprayed lines, other than yellow – 1.5 mm minimum

4) Extruded lines – 3.0 mm ± 0.5 mm

S11.1.10 Cold applied road markings (e.g. methyl methacrylate) may be used as an alternative to hot-applied thermoplastic materials provided that they at least match the appropriate BS EN 1824 durability and BS EN 1436 performance requirements as set out in this section.

S11.1.11 The performance requirements for permanent road marking materials must have been established from road trials in accordance with BS EN 1824. The material used to reinstate road markings must be in accordance with Table S11.1.

Table S11.1 Performance requirements for road markings

Road type	Required toll-over class (BS EN 1824:2011 Table 3)
0	P5
1 to 4 & footways/footpaths/cycle tracks	P4

Road markings – Small openings

S11.1.12 Road markings for small openings (as defined in S1.5.4) must meet the criteria in S11.1.5 to S11.1.11. Alternative materials may be used, subject to the following:

1) Road marking tape may be used in place of thermoplastic markings or marking paint – individual tape lengths must be no more than 2.5 m.

2) Pre-formed thermoplastic markings may be used in place of hot applied thermoplastic materials – individual lengths must be no more than 2.5 m.

3) No alternatives may be used in place of specialist materials such as rib markings without the approval of the authority.

S11.2 Street furniture and special features

- S11.2.1 Street furniture and features such as tactile paving that have been removed to facilitate street works must be carefully stored during the works. They must be replaced in their original locations before opening the highway to traffic and pedestrians. Advice on replacement may be provided by the authority.

S11.3 Traffic sensors, etc.

- S11.3.1 Where excavation is planned at or near to traffic sensors etc, advice on precautions to avoid damage must be sought from the relevant authority before work starts.

S11.4 Water-related matters

Sewers, drains and tunnels

- S11.4.1 An undertaker executing street works that involve breaking up or opening a sewer, drain or tunnel that is vested in or owned by another responsible authority must obtain the approval of that authority before executing the works.
- S11.4.2 In the case of a public sewer, “responsible authority” means the sewerage undertaker (i.e. the water service company for the relevant area).
- S11.4.3 In the case of any other sewer, drain or tunnel, the “responsible authority” means the owner (or the authority, body or person) responsible for the management or control of the sewer, drain or tunnel.
- S11.4.4 Where the responsible authority knows of the existence of sustainable drainage systems (SuDS) in areas likely to be affected by the undertaker’s work, they must inform the undertaker, so that an appropriate excavation and reinstatement method can be agreed.

Water egress (reinstatements)

- S11.4.5 If water issues from a reinstatement, the street authority must initiate an investigatory works procedure to determine the cause. Before starting any investigatory work, the authority should contact any undertakers it believes may be responsible for the water egress. Undertakers must cooperate with the authority in its investigation.
- S11.4.6 If following the investigation the authority has reasonable cause to believe that water egress has been caused by an undertaker’s operations, remedial measures, at the undertaker’s cost, must be agreed between the authority and the undertaker.

Water egress (street surface and utility apparatus)

- S11.4.7 Notes for Guidance are provided to cover situations where water issues from the street surface or an undertaker's apparatus.

S11.5 Ironwork in roads, footways, footpaths and cycle tracks**Access covers, frames and surround**

- S11.5.1 The installation, construction and maintenance of apparatus such as access covers and frames form an integral part of street works. Works undertaken to apparatus must be to the standard and specification of the owner of the apparatus.
- S11.5.2 The sub-structure of an underground chamber supporting an access cover and frame is constructed in such a way that it is not usually possible to achieve a full depth reinstatement in the area defined as the 'access surround'. The access surround is the area between the fixed feature (access frame) and the point at which a full depth reinstatement can be achieved with a full load transfer. In the area of the access surround, it may not be possible to reinstate surface or binder courses to the required thickness, e.g. where the distance between the frame and the surface is less than 100 mm. In this case, a surfacing material may be used as binder course.

Reinstatement materials

- S11.5.3 Reinstatements around ironwork must comply with S4, S5, S6 for flexible roads, S7 for rigid and modular roads, S8 for footpaths, footways and cycle tracks. In addition, clauses S11.5.4 to S11.5.6 include alternative options specific to reinstatement around ironwork and apparatus.
- S11.5.4 Bedding materials that require curing for strength gain must be allowed to cure before constructing the next layer.
- S11.5.5 *Bedding materials used in reinstatements*
- 1) Bedding material, including C32/40 strength concrete may be used to fill the excavation to within 100 mm of the road surface and within 350 mm of the edge of the access chamber frame cover.
 - 2) To provide a long service life in high stress areas such as braking and turning areas, consideration should be given to the use of PMMA (see S6.5.6 to S6.5.10).

S11.5.6 *Backfill and sub-base*

Backfill and sub-base may be:

- 1) concrete with a Product Acceptance Scheme certificate. Installation and curing must be carried out as per the requirements in the certification. The substrate must be pre-wetted, and any standing water removed.
- 2) PMMA (see S6.5.6 to S6.5.10)
- 3) substituted by bedding materials (see S11.5.4.).

S11.5.7 *Surfacing*

Surfacing materials may be:

- 1) PCSM: must comply with A2.4. and must be suitable for reinstatements around ironwork. Compaction must be in accordance with A8. Before application, the outside of the frame and all exposed edges and joints must be primed with an edge sealant (see S6.8).
- 2) Asphalt: complying with CD 534. Also refer to A2 to A4.
- 3) PMMA (S6.5.6 to S6.5.10)

Compaction

S11.5.8 Compaction in accordance with S10.3. around ironwork and apparatus is the preferred method and it must be used, with the following restrictions:

- 1) Mechanical pole tampers may be used as an alternative in footways, footpaths and cycle tracks.
- 2) Flowable materials may be used as per S11.5.16 to avoid the requirement for compaction
- 3) In footways, footpaths and cycle tracks, hand compaction may be used if there are restrictions, such as kerbs, other ironwork or street furniture, that do not allow compaction in accordance with S10.3 or the use of mechanical pole tampers. In this case, hand compaction may be used only:
 - a) where it can be shown to be the undertaker's custom and practice for the works before this edition of this Code; or
 - b) via A9, using the track record of compliance with S2 requirement as evidence; or
 - c) by agreement.
- 4) In roads, hand compaction may be used if there are restrictions, such as kerbs, other ironwork or street furniture, that do not allow compaction in accordance with S10.3 or the use of mechanical pole tampers. In this case, hand compaction may be used only:
 - a) via A9, using the track record of compliance with S2 requirement as evidence; or
 - b) by agreement.

Excavation

S11.5.9 Before applying any bedding, backfill or surfacing material, the receiving surface must be free from loose excavation material and loose supporting materials, and the area must be clear of debris and free from oil, grease, dust or any other visible contaminant.

S11.5.10 Edge preparation of the excavation must comply with S6.8 for flexible roads, S7.5 for rigid and modular roads and S8.6 for footpaths, footways and cycle tracks.

S11.5.11 All loose excavation material and the existing frame must be removed and the structure prepared to receive the new frame.

- S11.5.12 All loose supporting materials e.g. proprietary packing materials, engineering bricks etc., must be removed.
- S11.5.13 A suitable edge sealant and, where necessary, a primer must be applied to the frame and on the bedding material where concrete is used as the bedding material.

Trimback

- S11.5.14 The width of trimback is dependent on the reinstatement materials used.

S11.5.15 *Reinstatement materials that require compaction*

If reinstatement materials are used that require compaction e.g. granular sub-base, HRA, etc., the width of trimback required will be the width of the frame base plus the width of the compaction tool sole plate plus 30 mm.

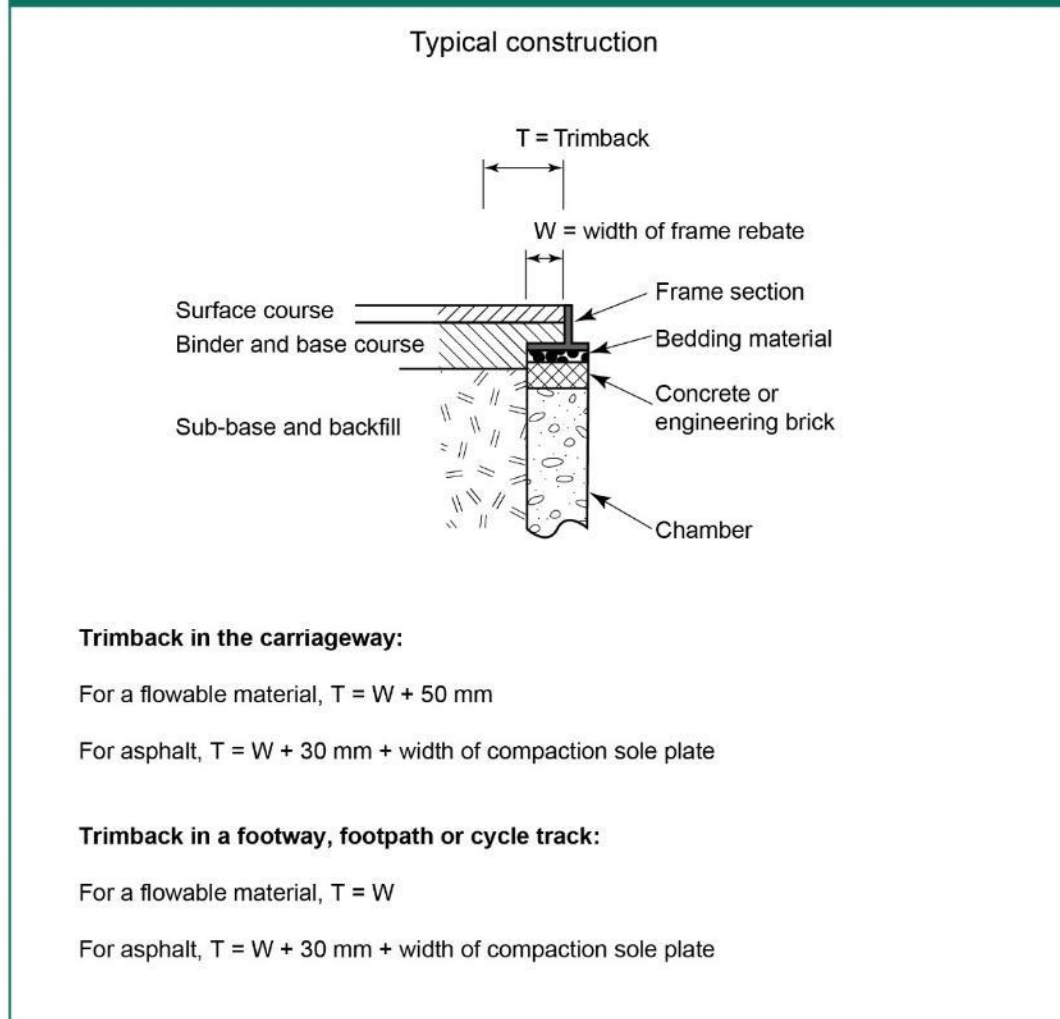
S11.5.16 *Reinstatement materials that do not require compaction*

If reinstatement materials are used that do not require compaction e.g. concrete or PMMA, then a minimum width of trimback will be required to install the apparatus and ensure depth of penetration of the reinstatement material. For roads this will be a minimum of 50 mm in excess of the flange width. For footways, footpaths and cycle tracks the minimum width of trimback is the width of the frame.

Typical construction details

- S11.5.17 Figure S11.1 shows typical construction for a reinstatement next to a chamber.

Figure S11.1 Reinstatement next to a chamber



Reinstatements around and between small features

- S11.5.18 When a reinstatement is needed around or between small features, PMMA complying with A2.5.1 and A2.5.2 may be applied as backfill, sub-base, base and surfacing material. Other materials permitted in Section S11.5 may be used if appropriate compaction can be achieved.

S11.6 Test holes

- S11.6.1 Test holes over 150 mm diameter are regarded as excavations and must be reinstated to comply with this Code. Test holes of nominal 150 mm diameter or less are not excavations for the purposes of this Code and must be reinstated to a permanent standard within 10 working days of completion of all associated work on site.

General

- S11.6.2 Before reinstatement, all test holes should be made safe and maintained in a safe condition.
- S11.6.3 Test holes up to 25 mm diameter must be reinstated to an immediate permanent standard.

S11.6.4 Test holes larger than 25 mm diameter may be reinstated to an interim standard if required.

S11.6.5 In modular surfaces, preference should be given to lifting individual modules before drilling test holes whenever reasonably practical.

S11.6.6 In unmade ground, test holes must be tamped closed or filled with appropriate materials.

50 mm diameter or less

S11.6.7 Test holes must be reinstated to finish flush with the surface by any of the following methods:

- 1) Using a fine aggregate bound with cement or bitumen for the upper layers as appropriate, and compacted in layers 100 mm thick, or less.
- 2) Using a self-compacting proprietary product.
- 3) Using a flexible sealing plug. The void beneath the flexible sealing plug must be reinstated using sand and cement mix or a proprietary product.
 - a) In bituminous surfaces, all sealing plugs must be coloured black (or dark grey).
 - b) In modular or concrete surfaces, sealing plugs must be coloured white (or light grey) or black (or dark grey) as appropriate.

S11.6.8 If a flexible sealing plug becomes dislodged during the guarantee period, the undertaker must replace it.

50 to 150 mm diameter

S11.6.9 In paved surfaces, test holes must be reinstated using a fine aggregate, appropriately compacted in layers 100 mm thick or less, and surfaced with appropriate cementitious, cold or hot-lay bituminous materials to finish flush with the surface.

S12 Remedial works

S12.1 General

S12.1.1 The undertaker is responsible for ensuring that reinstatements meet the required performance criteria throughout the guarantee period.

S12.1.2 When determining the exact scope of the remedial action for a non-compliant reinstatement, the quality of the reinstatement must be assessed relative to the condition of the adjacent structure. Other considerations are:

- 1) The long-term durability of the highway asset
- 2) The additional congestion that may be caused by the remedial work
- 3) The environmental impact
- 4) Public perception

Any agreement between both the authority and the works undertaker, including an agreement that no remedial works are required, should be recorded on the relevant street works notice or permit.

S12.1.3 Where remedial works are completed the guarantee period shall only be reset in accordance with S2.1.4.

S12.2 Safety requirements

S12.2.1 Should a reinstatement fail any safety requirements of this Code (S2), the surface must be restored to comply with such requirements.

S12.3 Repair of cracking

Interface cracking

S12.3.1 Cracking along the reinstatement interface greater than 2.5 mm wide at the surface for more than the maximum permitted length shown in Table S12.1 will require remedial action in accordance with S12.3.3.

Table S12.1 Interface cracking

Reinstatement	Surface	Maximum crack length
Small openings	All Surfaces	500 mm total cumulative length
Large diameter cores, micro trenches, narrow trenches, other openings and deep openings	Footway	1000 mm maximum crack length or 10% of reinstatement perimeter whichever is greater
	All carriageway Types	500 mm maximum crack length or 10% of reinstatement perimeter whichever is greater

Cracking beyond reinstatement limits

S12.3.2 Cracks remote from a reinstatement interface greater than 2.5 mm wide at the surface for more than 2 m of continuous length will also require remedial action in accordance with S12.3.3, provided it can reasonably be shown that such cracks occurred directly as a result of the undertakers' works.

Repair of interface cracking

S12.3.3 Cracking along the interface of a reinstatement must be repaired in accordance with the following:

- 1) Crack sealing systems must have a current Product Acceptance Scheme certificate.
- 2) Hot or cold applied systems may be used, subject to manufacturer's recommendation on application under the prevailing weather conditions.
- 3) Treatments must be black in colour, unless otherwise directed by the authority.
- 4) The minimum PSV of the repair system surface is as specified for the type of surfacing (see S2).
- 5) The initial skid resistance must be >55 SRV as measured by the pendulum tester using the narrow slider in accordance with BS EN 13036-4.
- 6) Installation and Quality Control Procedures for all systems must be in accordance with the Product Acceptance Scheme certificate. The results of all quality control checks carried out on site and quality assurance information must be compiled in accordance with the requirements of the Product Acceptance Scheme certificate.
- 7) Preparation must be in accordance with the installation Method Statement and must include cleaning and removal of debris and contamination with a hot air lance. The substrate must be dried fully before applying the crack treatment.
- 8) Depending on the width of the crack an appropriate sealing system must be chosen:
 - a) Cracks between 2.5 and 5 mm wide must be repaired with an overband sealing system, as described in S6.8.8.

- b) Cracks between 5 mm and 20 mm wide must be repaired by infilling it with a flexible bituminous sealant and then applying a surface sealing band up to 200 mm wide.
- c) Cracks widths over 20 mm require a surface repair, as follows:
 - i. The surfacing materials must be removed to the full depth of the surface course or to 40 mm, whichever is the lesser, for the full length of the crack or for 1 m length, whichever is greater. If the crack extends into the binder course layer, the affected materials must be removed and replaced in accordance with S6.4.
 - ii. Surfacing materials must be removed over sufficient width to ensure that the repair patch extends beyond the edges of the crack by a minimum distance equal to the nominal thickness of the replacement surface course. The minimum width of the repair patch is 100 mm.
 - iii. Inclusion of a geosynthetic material at the base of the repair patch could assist in limiting any reoccurrence of cracking.
 - iv. The replacement surface course patch must be laid in accordance with S6.4.
- 9) Where, as a result of an undertaker's works, a crack requiring repair in accordance with S12.3.3 exists within 300 mm of another similar crack repair, the intermediate area must be included in the new repair.

Cracking within high friction surfaces

- S12.3.4** Where cracks appear in high friction surfacing, then provided that the surfacing is well bonded to the substrate, and with the agreement of the authority, the cracking may be sealed using a suitable epoxy or similar resin and the high friction surfacing made good. Guidance on this should be sought from the system supplier or the Product Acceptance Scheme certificate.

S12.4 Repair of settlement beyond reinstatement limits

- S12.4.1** Where significant settlement of the surface beyond the edges of the reinstatement can reasonably be shown to have occurred as a direct result of an undertaker's works, the effective width of the reinstatement must be revised to include the actual width of the settled area. The relevant requirements of this Code apply over the revised width of the reinstatement.
- S12.4.2** The extent of any significant settlement beyond the reinstatement limits must be assessed, by agreement, from consideration of the following:
- 1) The apparent extent of any excessive areas of standing water following heavy rainfall; or
 - 2) The apparent extent of any significant deterioration of highway shape compared with the existing profile remote from the excavation; or
 - 3) The true extent of any significant deterioration of highway shape determined by profile measurements taken before and after the undertaker's works.

S12.4.3 Where the remedial works increase the dimensions of the original site registration this is a new reinstatement with a new guarantee period.

S12.5 Repair of other significant defects

S12.5.1 The requirement for, and extent of, any repair must be determined by agreement from a consideration of the existing and adjacent surfaces.

S12.5.2 Where it can reasonably be shown that a repair is required as a direct result of an undertaker's works, the undertaker must carry out remedial actions as necessary.

Appendix A1 Backfill materials

A1.1 Class A – Graded granular materials

- A1.1.1 Materials should be well-graded granular material with a uniformity coefficient greater than 10. Material must, at the time of compaction, be at an appropriate moisture content between +1% and -2% of the optimum moisture content as determined by BS 1377-4, Vibrating Hammer Method, Method 3.7, or must be acceptable when subjected to field identification test No.3.
- A1.1.2 Materials must show a maximum Los Angeles coefficient of LA60 when tested in accordance with BS EN 1097-2.
- A1.1.3 Modified Type 1F Unbound Mixture must comply with A10.1.

A1.2 Class B – Granular materials

- A1.2.1 Material at the time of compaction must be at an appropriate moisture content, between +1% and -2% of the optimum moisture content as determined by BS 1377-4, Vibrating Hammer, Method 3.7, or must be acceptable when subjected to field identification test No.3.

A1.3 Class C – Cohesive/granular materials

- A1.3.1 Materials with less than 50% granular content by mass must, at the time of compaction, have a moisture content of between 0.8 and 1.2 times the plastic limit or be acceptable when subjected to field identification test No.2.
- A1.3.2 Materials with a minimum of 50% granular content by mass must, at the time of compaction, have a moisture content of between +1% and -2% of the optimum moisture content as determined by BS 1377-4, Vibrating Hammer, Method 3.7, or must be acceptable when subjected to field identification test No.3.

A1.4 Class D – Cohesive materials

- A1.4.1 Cohesive materials at the time of compaction must have a moisture content of between 0.8 and 1.2 times the plastic limit or be acceptable when subjected to field identification test No. 2.
- A1.4.2 Clays that contain insufficient moisture when excavated, or have dried excessively during site storage, as defined by field identification test No. 2, may only be re-used provided that they are wetted to comply with A1.4.1 and compacted in accordance with A8 for Class D Cohesive Materials.

A1.4.3 It may be difficult to compact cohesive materials to uniformly achieve an adequate bearing capacity. Undertakers must select a lump size for clays within the limits specified in A2 and must ensure that all compaction equipment is operated within the requirements of A8. Failure to comply with A2 or A8 will result in unacceptable settlement and variable bearing capacity.

A1.4.4 High silt content materials, as defined by field identification test No. 1, must be compacted in accordance with A8 requirements for Class D Cohesive Materials.

A1.5 Class E – Unacceptable materials

A1.5.1 The following materials, listed as unacceptable in MCHW Clause 601 paragraphs 2(ii) and 3, must not be used at any level within the permanent structure of any reinstatement:

- 1) Peat and materials from swamps, marshes or bogs.
- 2) Logs, stumps and perishable materials.
- 3) Materials in a frozen condition. Such materials, if otherwise suitable, can be classified as suitable when unfrozen.
- 4) Clays having a liquid limit exceeding 90, determined in accordance with BS 1377-2 Method 4, or a Plasticity Index exceeding 65, determined in accordance with BS1377-2, Method 5.4.
- 5) Materials susceptible to spontaneous combustion.
- 6) Materials having hazardous chemical or physical properties requiring special measures for excavation, handling, storage, transportation, deposition and disposal.

A1.6 Field identification tests

A1.6.1 The following identification tests must be carried out immediately before placement and compaction of backfill material.

Field identification test No 1 – Silt identification

A1.6.2 High silt content materials can usually be identified by a simple hand test:

A1.6.3 *Preparation*

Select a moist sample of the fine material only.

A1.6.4 *Test – Silt identification*

With clean dry hands, rub the sample between the palms, remove the excess material by striking the palms together and wait a few minutes for body heat to dry out any material adhering to the hands. Finally, rub hands together briskly.

A1.6.5 *Result*

If no significant quantity of material remains adhering to the palms, i.e. the palms are relatively clean, then the sample tested is essentially a silt.

Note: The proportion of granular material discarded to produce the fine sample must be taken into account when estimating the approximate silt content of the bulk material.

Field identification test No 2 – Clay condition

A1.6.6 Clays suitable for compaction with pedestrian controlled compaction plant can usually be identified by a simple roll test:

A1.6.7 *Preparation*

Select a sample of small lumps of the fine material only, at a moisture content representative of the bulk material.

A1.6.8 *Test – Clay Condition*

With clean dry hands, take the sample and squeeze together in one hand and release. If the sample crumbles away and mostly fails to hold together into a ball then the sample is too dry for compaction. If not, break off part of the ball and roll between the palms or between one palm and any convenient clean dry flat surface, for example the back of a spade. Roll out the sample into a long thin cylinder until it fractures or begins to show significant transverse cracks.

A1.6.9 *Result*

If the strand can be rolled into intact or uncracked lengths that are thinner or longer than a typical pencil, i.e. less than 7 mm diameter or more than 175 mm length then the sample is too wet or too plastic for compaction. Any result between the ball and the pencil is acceptable for use provided the bulk of the material consists of lumps smaller than 75 mm.

Field identification test No 3 – Granular condition

A1.6.10 All granular materials including Clause 803 Type 1 granular sub-base must be compacted near to their optimum moisture content. The optimum moisture content can vary considerably depending on the average particle size and, to a much smaller extent, on the type of mineral or rock involved. However, a laboratory compaction test is invariably carried out on a sample of material from which the larger particles have been removed. The sample is always compacted in a small smooth sided steel cylinder and the standard methods of compaction bear little similarity with current compaction plant. Experience has shown that the most commonly specified laboratory compaction test i.e. BS 1377-4, Vibrating Hammer, Method 3.7 will produce an optimum moisture content result that is typically significantly wetter than the field optimum for a granular material that is to be compacted within a trench using a vibrotamper.

A1.6.11 Granular materials suitable for compaction by pedestrian-controlled plant can usually be identified by a simple visual examination. Typically, the test will identify materials within 1% to 1.5% of the field optimum moisture content depending on the mineral type. Experience has shown that compaction within this visual moisture range will not normally show any significant reduction in compaction performance. The test cannot indicate the actual moisture content of any material, but this is rarely of any relevance as far as an operator is concerned.

A1.6.12 *Preparation*

Depending on the size of the stockpile, dig out representative samples from beneath the outer surface, at several positions around the outside in a conical shape.

A1.6.13 *Test – Coarse aggregate*

Examine several of the medium and larger sized particles from each sample extracted.

A1.6.14 *Result*

- 1) Material within the target moisture content range will show a dull sheen when viewed obliquely against the light with all fines adhering to the larger particles, and no free water will be visible. Material at the dry limit will not show the characteristic sheen, fines will not be strongly adherent and many of the fines will be free. Material at the wet limit will begin to show free moisture collecting in surface grooves or amongst the fines, fines will not be strongly adherent and many of the fines will amalgamate as soggy clusters. Any result between the wet and dry limits is acceptable provided the bulk of the sample is reasonably well graded.
- 2) Sands used as fine fill or as a regulating layer also need to be used near to the optimum moisture content and can be identified by a simple squeeze test.

A1.6.15 *Test – Fine aggregate*

Take a small sample of representative sand, squeeze in one hand and release.

A1.6.16 *Result*

If the sample crumbles away and mostly fails to adhere together into a 'ball' then the sample is too dry. Any reasonable degree of adherence is acceptable provided no free water is squeezed out.

Field identification test No 4 – Granular grading

A1.6.17 All unbound granular materials must be reasonably well graded i.e. they must contain a range of particle sizes from fine to coarse, with an adequate proportion of particles of intermediate sizes. A well-graded material can be compacted to give a dense and stable structure of interlocking particles with a low proportion of air voids within the structure.

A1.6.18 *Preparation*

Depending on the size of the stockpile, dig out representative samples from beneath the outer surface at several positions around the outside.

A1.6.19 *Test – Granular grading*

Spread out each sample and examine under good light.

A1.6.20 *Result*

Class A graded granular materials – should not contain any particles greater than 75 mm nominal size and, in general, should be 50 mm or less. Smaller particles down to less than 5 mm nominal size should be present in gradually increasing numbers as the size decreases. Finer particles from sand size down to dust should be present and will usually be adhering to the larger particles. Fine particles should be visible adhering to around 30% or more of the surfaces of most of the larger particles.

Class B granular materials – should show the same general features as described above but will usually be less well graded overall compared with Class A Graded Granular Materials.

Class C Cohesive/granular materials – will usually contain a much larger proportion of fine material. The granular content should still be less than 75 mm nominal size, down to less than 5 mm nominal size and should not be single sized.

Appendix A2 Key to materials

A2.0 Introduction

- A2.0.1 The substantial majority of reinstatements are small rectangular openings and trenches. By implication, these reinstatements can be considered to be carried out in confined areas.
- A2.0.2 Undertakers primarily adopt hand laying operations in their reinstatements, rather than machine laying operations associated with new-build and larger surface area situations, i.e. relatively unconfined areas. In addition to the final compaction of asphalt layers, hand laying operations also include on-site transportation and handling of the asphalt materials.
- A2.0.3 Materials in this appendix are predominantly for hand laying operations. Some asphalts incorporating highly modified polymer modified binders (PMBs) may not be suitable for hand-laying and should only be used by agreement. Clause 943 HRA incorporating PMB must not be hand-laid.

Roads – General

- A2.0.4 In small openings and narrow trenches, the preferred binder course mixture may be replaced by any surface course mixture that complies with this Code for the respective road type provided that the same mixture is used in the surface course, see S6.5.

Footways, footpaths and cycle tracks – General

- A2.0.5 In all excavations, the preferred binder course mixture may be replaced by any surface course mixture that complies with this appendix and S8. This substitution is limited solely to the binder course layer. Void contents must meet the requirements of Table S10.1 for footpaths.

A2.1 Hot rolled asphalt (HRA) mixtures

- A2.1.1 All HRA must conform to BS EN 13108-4. Conformity must be established in accordance with BS EN 13108-20 and BS EN 13108-21. Natural gravels are not permitted as coarse aggregate for use in Types 0, 1 and 2 roads.
- A2.1.2 Deformation resistance must comply with the limiting wheel tracking requirements for site classifications in accordance with PD6691 Appendix C, Table C.3.
- A2.1.3 Design Type C mixtures listed in this section may only be used by agreement where satisfactory local experience has been gained in their use.

Surface course mixtures

- A2.1.4** The following preferred HRA surface course mixture options may be replaced by any of the permitted mixtures.
- A2.1.5** Chippings for surface application to HRA surface course mixtures must be coarse aggregate conforming to PD 6691 appendix C, C.2.3 and meet the requirements of C.2.8. The size and grading of chippings must be 14/20 as in Table C.5. Where the existing surface has 8/14 chippings, these may be used in the reinstatement. Where pre-coated chippings are to be embedded into a road surface, they must be spread to give a chipping density as per BS 594987 or reasonably matching that of the existing surface notwithstanding the requirements for surface texture specified in S2.6.
- A2.1.6** *Roads Type 0 and 1*
- 1) The preferred surface course mixture is HRA 35/14 F surf PMB with the wheel tracking requirements meeting classifications 2 for road Type 0 and classification 1 or 2 for road Type 1. The wheel tracking classification 2 for road Type 1, should be selected for heavily stressed areas such as bus lanes, roundabouts and approaches to pedestrian crossings and traffic lights. The approach areas are considered as the 50 m before the traffic light or pedestrian crossing. These areas may be extended depending on the likelihood of traffic having to brake unexpectedly.
 - 2) Alternative permitted mixtures are:
 - a) HRA 30/14 F surf PMB des
 - b) HRA 35/14 F surf 40/60 des
 - c) HRA 30/14 C surf 40/60 des (before use refer to A2.1.3)
 all with the wheel tracking requirements meeting classification 2 for road Type 0 and classification 1 or 2 for road Type 1. The wheel tracking classification 2 for road Type 1 should be selected for heavily stressed areas such as bus lanes, roundabouts and approaches to pedestrian crossings and traffic lights.
- A2.1.7** *Roads Type 2*
- 1) The preferred surface course mixture is HRA 35/14 F surf 40/60 des.
 - 2) Alternative permitted mixtures are:
 - a) HRA 30/14 F surf 40/60 rec
 - b) HRA 30/14 F surf 40/60 des
 - c) HRA 30/14 C surf 40/60 des (before use refer to A2.1.3)
 - d) HRA 35/14 surf 40/60 rec
- A2.1.8** *Roads Type 3 and 4*
- 1) The preferred surface course mixture is HRA 35/14 F surf 40/60 des.
 - 2) Alternative permitted mixtures are:
 - a) HRA 30/14 F surf 40/60 des

b) HRA 30/14 C surf 40/60 des (before use refer to A2.1.3)

c) HRA 30/10 or 30/14 F surf 40/60 rec

d) HRA 55/14 F surf 40/60 or 100/150 des

e) HRA 55/10 F surf 40/60 or 100/150 des

When a, b or c are used as the binder course in narrow trenches or small excavations, they must have wheel tracking requirements meeting classification 2.

A2.1.9 *Footways, footpaths and cycle tracks*

- 1) The preferred HRA surface course mixture is HRA 15/10F surf 100/150 rec.
- 2) HRA 30/10F surf 70/100 or 100/150 or 40/60 rec is an alternative permitted mixture.
- 3) Areas that exhibit signs of regular trafficking by commercial vehicles or such sites notified to the undertaker by the authority must be reinstated in accordance with S8.7.

HRA binder course mixtures

A2.1.10 *Road Type 0 & 1*

The binder course mixture must be HRA 60/20 F bin 40/60 des with the wheel tracking requirements meeting classification 2 for road Type 0, and classification 1 or 2 for road Type 1. For road Type 1, classification 2 should be selected for heavily stressed areas such as bus lanes, roundabouts, and approaches to pedestrian crossing or traffic lights.

A2.1.11 *Road Types 2, 3 and 4*

- 1) The preferred HRA binder course mixture is HRA 50/20 F bin 40/60.
- 2) Alternative permitted mixtures (a) and (b) below may be used by agreement where satisfactory local experience has been gained in their use.
 - a) Openings up to 500 mm width – HRA 50/14 F bin 40/60.
 - b) Openings over 500 mm width – HRA 60/20 F bin 40/60.

A2.1.12 *Footways, footpaths and cycle tracks*

- 1) The preferred binder course mixtures are HRA 50/20 F bin 100/150 or, HRA 50/20 F bin 70/100 or HRA 50/20 F bin 40/60.
- 2) Alternative permitted mixtures (a) and (b) below may be used by agreement where satisfactory local experience has been gained in their use.
 - a) Openings up to 500 mm width – HRA 50/14 F bin 100/150 or, HRA 50/14 F bin 70/100 or HRA 50/14 F bin 40/60.
 - b) Openings over 500 mm width – HRA 60/20 F bin 100/150 or, HRA 60/20 F bin 70/100 or HRA 60/20 F bin 40/60.
- 3) Areas that exhibit signs of regular trafficking by commercial vehicles or such sites notified to the undertaker by the authority must be reinstated

in accordance with S8.7. In such situations the preferred binder course mixture must not be replaced by any carriageway surface course mixture and 100/150 pen material must not be used.

- 4) In areas not subject to vehicular trafficking, the preferred binder course mixture may also be replaced by any permitted carriageway surface course mixture.

A2.2 Stone mastic asphalt (SMA) mixtures

A2.2.1 SMA must conform to BS EN 13108-5 and PD 6691. Conformity must be established in accordance with BS EN 13108-20 and BS EN 13108-21. The following SMA mixtures are permitted by this Code, depending upon the detail requirements of the relevant section.

A2.2.2 Requirements for deformation resistance as assessed by wheel tracking performance (WTR) are in accordance with PD6691 appendix D, Table D.2 and the note to that table.

Surface course mixtures

- 1) The required performance properties are to be set by agreement with the authority.
- 2) Certificated TSCS must comply with MCHW Clause 942 or the authority's specification.
- 3) SMA mixtures must match the existing nominal size aggregates except for when hand-laying, where mixtures with 10 mm nominal aggregate size must be used to reinstate the existing SMA materials with 20 mm and 14 mm nominal aggregate size. SMA incorporating PMB may only be hand-laid by agreement.

A2.2.3 *Roads Type 0 and 1*

- 1) The permitted mixtures are:
 - a) SMA 14 surf PMB
 - b) SMA 14 surf 40/60
 - c) SMA 10 surf PMB
 - d) SMA 10 surf 40/60
 all with wheel tracking requirements meeting classification 2.
- 2) Alternative permitted mixtures subject to the authority's approval are:
 - e) SMA 6 surf PMB
 - f) SMA 6 surf 40/60
 both with wheel tracking requirements meeting classification 2.

A2.2.4 *Roads Type 2, 3 and 4*

The permitted mixtures are:

- a) SMA 14 surf PMB or 40/60 or 100/150
- b) SMA 10 surf PMB or 40/60 or 100/150

Alternative permitted mixtures subject to the authority's approval are:

- c) SMA 6 surf PMB or 40/60 or 100/150 (see S6.4.3 to S6.4.6)

A2.2.5 *Footways, footpaths and cycle tracks*

The permitted surface course mixtures, unless advised otherwise by the authority, are:

- a) SMA 6 surf 40/60
- b) SMA 6 surf 70/100
- c) SMA 6 surf 100/150

SMA binder course mixtures

A2.2.6 *Roads Type 0 and 1*

- 1) The preferred binder course mixture is SMA 20 bin 40/60 with wheel tracking requirements meeting classification 2.
- 2) Alternative permitted mixture is SMA 14 bin 40/60 with wheel tracking requirements meeting classification 2.

A2.2.7 *Roads Type 2, 3 and 4*

The preferred binder course mixtures are:

- a) SMA 20 bin 40/60 or SMA 20 bin 100/150.
- b) Openings up to 500 mm width – as a) or SMA 14 bin 40/60 or SMA 14 bin 100/150.

A2.3 **Asphalt concrete mixtures**

A2.3.1 Asphalt concrete must conform to BS EN 13108-1. Conformity must be established in accordance with BS EN 13108-20 and BS EN 13108-21. The following coated mixtures to BS EN 13108-1 and PD 6691 are permitted depending upon the detailed requirements of the relevant section.

A2.3.2 Where the existing mixture is HDM (heavy duty mixture to PD 6691) or HMB (high modulus base) and the authority requires the reinstatement to be completed using a similar mixture, the authority must notify the undertaker accordingly.

A2.3.3 Deformation resistance must comply with the limiting wheel tracking requirements for site classification in accordance with PD 6691 appendix B, Table B.4 and the note to that table.

A2.3.4 For road Types 0 and 1, material must comply with the wheel tracking requirements for site classification 2. There is no wheel tracking requirement for other road types.

Surface course mixtures

A2.3.5 *All road types*

- 1) The coated surface course mixtures to PD 6691 must be AC10 close surf 100/150.

- 2) AC10 close surf can be specified to have binder content (B_{act}) higher than those specified in PD 6691 Table B.14 and Table B.15 respectively to enhance workability during installation and improve in-service life. This binder content increase must be done by agreement where evidence of successful experience has been presented; including avoiding adverse impact on rutting and skid resistance.

A2.3.6 *Footways, footpaths and cycle tracks*

- 1) The preferred coated surface course mixture is AC6 dense surf 100/150 complying with BS EN 13108-1. The binder content (B_{act}) can be specified to be higher than in PD 6691 Table B.15 to enhance workability during installation and improve in-service life.
- 2) Where AC10 close surf incorporating 100/150 bitumen complying with BS EN 13108-1 is used to reinstate a carriageway and it extends to the footway (maximum total of 10 linear m or 4 m² in the footway, footpath or cycle track for a continuous reinstatement), the same material can be used in the footway. The binder content (B_{act}) can be specified to be higher than in PD 6691 Table B.15 to enhance workability during installation and improve in-service life. Where the linear m or m² of the reinstatement in footways, footpaths and cycle tracks exceed the values in this clause, then AC10 may only be used by agreement.
- 3) The preferred mixture may be replaced by other agreed alternative materials where the existing surface is a coated mixture to the current PD 6691 of aggregate size finer than 6 mm nominal size.

Binder course mixtures

A2.3.7 *Road Type 0 & 1*

The preferred binder course mixture to PD 6691 is AC20 dense bin 40/60 with the wheel tracking requirements meeting classifications 2 for road Type 0 and 1 or 2 for road Type 1.

A2.3.8 *Road Types 2, 3 & 4*

The preferred binder course mixture to PD 6691 is AC20 dense bin 100/150.

A2.3.9 *Footways, footpaths and cycle tracks*

The binder course mixture in footways, footpaths and cycle tracks must be either AC20 dense bin 100/150 or AC14 dense bin 100/150. For hand compaction (see S6.5) AC14 dense bin 100/150 is preferred.

The binder content (B_{act}) can be specified to be higher than in PD 6691 Table B.15 to enhance workability during installation and improve in-service life.

A2.4 Cold-lay surfacing materials

Permanent cold-lay surfacing materials (PCSMs)

- A2.4.1 Only PCSMs with a current Product Acceptance Scheme certificate can be used for permanent reinstatements.
- A2.4.2 PCSMs must be stored, transported, handled and used strictly in accordance with the manufacturer's requirements contained in the Product Acceptance Scheme certificate for that material.
- A2.4.3 Approved PCSMs, laid and compacted in accordance with the Product Acceptance Scheme certificate may be used in substitution for any permitted equivalent bituminous material type, such as an SMA or AC, at the discretion of the undertaker, as follows:
- 1) Permanent cold-lay surfacing material (PCSM), at any position, in all reinstatements in footways, footpaths and cycle tracks.
 - 2) Permanent cold-lay binder course (PCBC) in all reinstatements in Type 3 & 4 roads.
 - 3) Permanent cold-lay surface course (PCSC) in all reinstatements in Types 3 & 4 roads.
- A2.4.4 The required thickness of the PCSM must be as stated in the Product Acceptance Scheme certificate.
- A2.4.5 Whenever a potential PCSM binder has begun a Product Acceptance Scheme PCSM approval trial, then regardless of aggregate or material formulation under trial, any material manufactured using that binder must be considered to be an approved deferred set material to PD 6691 for interim use only, with immediate effect.

Deferred set mixtures (DSMs)

- A2.4.6 Deferred set coated mixtures must be in accordance with PD 6691 and must be AC6 dense surf 160/220 DS (6 mm surface course) or AC10 close surf 160/220 DS (10 mm surface course) or AC20 dense bin 160/220 DS (20 mm dense binder course).
- A2.4.7 The binder grade and amount of flux oil may need to be amended to meet the performance requirements for surfacing mixtures for the duration of the interim reinstatement period. Advice on this is contained in PD 6691 appendix B.2.3.
- A2.4.8 Binder viscosity should be adjusted to give approximately the equivalent to 10 days deferred set.
- A2.4.9 Deferred set coated mixtures can be used at any position in interim and immediate reinstatements, but are not permitted within permanent reinstatements.

A2.5 Flowable materials

Polymer modified mastic asphalt (PMMA)

- A2.5.1 PMMA must be CE Marked to BS EN 13108-6 or have a Product Acceptance Scheme Certificate.

- A2.5.2 PMMA must have the following properties declared:
- 1) Grading limits as defined in section 5.2.2 from BS EN 13108-6:2016.
 - 2) Binder limits as defined in section 5.2.3 from BS EN 13108-6:2016. In any case, the minimum target binder content (B_{act}) must not be less than 8.0%.
 - 3) Indentation limits as defined in section 5.3.2 from BS EN 13108-6:2016. The indentation of specimens, determined in accordance with EN 12697-20 or EN 12697-21 using the conditions defined in EN 13108-20:2016, D.14, must not exceed category $I_{max10.0}$

Foamed concrete for reinstatements (FCR)

- A2.5.3 FCRs are cement-bound materials that have been prepared off-site or can be mixed on-site, generally as prescribed mixes, at an approved mixing plant and under appropriate quality control procedures. They are flowable and do not require compaction when placed. FCRs do not necessarily incorporate a coarse aggregate.
- A2.5.4 FCRs must not encase cables or be used within 300 mm of a gas pipe.
- A2.5.5 All aggregate used in FCRs must pass a 6.3 mm sieve and comply with the MP and FP grading limits given in BS EN 12620. Larger size aggregate may be used provided it can be shown to be practicable.
- A2.5.6 The composition of recycled aggregate including recycled concrete aggregate must be classified by hand sorting coarse aggregate particles in accordance with BS EN 933-11. The test must be carried out by a suitably trained laboratory technician competent in classifying the constituent classes in accordance with the test method. The content of other materials (Class X) must not exceed 1% by mass or by volume, whichever is the greater.
- A2.5.7 FCR permissible constituents must exclude potash and incinerator bottom ash aggregate (IBAA).
- A2.5.8 Layer thickness and compressive strength at 7 days requirements must be in accordance with Table A2.1.

Table A2.1 FCRs minimum layer thickness and compressive strength requirements

Layer	Road type					Footways, Footpaths and Cycle tracks
	0	1	2	3	4	
Combined Binder Course & Sub-base	NP	NP	NP	NP	NP	150 mm C1.5/2
Base	NP	NP	NP	300 mm C1.5/2	200 mm C1.5/2	---
Base & Sub-base	NP	450 mm C3/4	450 mm C3/4	450 mm C1.5/2	350 mm C1.5/2	---
Sub-base or below	150 mm C1.5/2	150 mm C1.5/2	150 mm C1.5/2	150 mm C1.5/2	150 mm C1.5/2	100 mm C1.5/2
Notes: NP = Not permitted Minimum asphalt overlay thickness as per A3 to A7. FCR is not permitted as CBGM base replacement.						

A2.5.9 FCR for backfilling excavations and trenches under carriageway must have the following compressive strengths:

- 1) A minimum cube compressive strength of 4 N/mm² at 7 days.
- 2) A maximum cube compressive strength of 10 N/mm² at 7 days.

A2.5.10 The compressive strength must be determined by testing foamed concrete cubes made in accordance with BS EN 12390-1, except that the FCR must be placed in the mould without any tamping or vibration other than gently rocking the mould on a firm base. Test cubes must be cured in accordance with BS EN 12390-2 and tested for compressive strength in accordance with BS EN 12390-3.

A2.5.11 The compressive strength of FCR must be determined in accordance with the principles of BS EN 12390-3, and the following:

- 1) Test specimens may be prepared at the time of placement by casting within a test mould or recovered from site by extracting cores from the reinstatement.
- 2) Specimen shape and dimensions must be in accordance with BS EN 12390-1 with the addition that specimens may also be manufactured with an aspect ratio of 1. Flowable moulds may be manufactured from cellular foam (preferably polystyrene) and include a cellular foam lid. The samples must not be compacted except for minimal tamping to allow the mould to be filled without leaving excessive areas of voids.
- 3) The top and bottom surfaces of core test specimens may be grouted to ensure flat, parallel loading surfaces.
- 4) Following preparation or recovery, the test samples must be stored upright at either 20°C or 40°C, depending on the nature of the material (in accordance with the manufacturer's instructions), and tested in compression at 7 days after placement of the material on site.

- A2.5.12 FCRs must be produced to prescribed mix formulations by an approved mixing plant in accordance with approved manufacturing processes under quality control procedures.
- A2.5.13 The wet density of FCRs must be checked before placement. Depending on the manufacturer's instructions, the quality of the foaming agent added on site must be checked before being incorporated in the mix. Any on-site addition of a foaming agent must be in accordance with the approved mix design.
- A2.5.14 In excavations containing water, the minimum density for foamed concrete is 1050 kg/m³.
- A2.5.15 The sub-base and base must not be reinstated over FCR until it has attained sufficient strength to allow compaction of the material.
- A2.5.16 FCRs must not be tamped or compacted unless otherwise specified by the manufacturer.
- A2.5.17 To avoid FCRs flowing into damaged drains or ducts in or adjacent to the excavation, plastic sheeting or other protective measures must be used during pouring and curing.
- A2.5.18 FCRs must be cured for the period specified by the manufacturer. During this period, the reinstatements must be protected.

A2.6 Reinstatement materials for micro trenches

Specification for granular material

- A2.6.1 The granular bedding material must comply with the requirements of Table A2.2.

Table A2.2 BS EN 13242 Fine aggregates for micro trenching

Category for general grading requirements	Category G _F 80
Category for tolerances on manufacturer's declared typical grading	GT _F NR (no requirement)
Category for maximum values of fines content	Gravel – f_3 Crushed rock recycled aggregate – f_{11}
Aggregate size, mm	0/4 or 0/6

- A2.6.2 The size fraction of the aggregate passing the 0.425 mm size test sieve must be non-plastic as defined by and tested in accordance with BS EN 17892-12 .

Specification for indicator infill material

- A2.6.3 This material must comply with the requirements of Table A2.3.

Table A2.3 Performance criteria for indicator infill material

Performance criteria	Procedure	Requirement
Material type	Not Applicable	Thermoset resin
Permanent deformation resistance	Wheel tracking to BS EN 12697-22 (Small device, Procedure A at 60°C)	WTR _{AIR15,0} and RD _{AIR7,0}
Tensile bond strength	Tensile bond tested in accordance with appendix J in TRL report 176	≥ 0.75 MPa
Elongation	BS EN ISO 527-1 & 3 – Plastics – determination of tensile properties	≥ 30%

Specification for surface infill material

A2.6.4 This material must comply with the requirements of Table A2.4.

Table A2.4 Performance criteria for surface infill material

Performance criteria	Procedure	Requirement
Material type	Not Applicable	Thermoset resin
Permanent deformation resistance	Wheel tracking to BS EN 12697-22 (Small device, Procedure A at 60°C)	WTR _{AIR15,0} and RD _{AIR7,0}
Tensile bond strength	Tensile bond tested in accordance with appendix J in TRL report 176	≥ 0.75 MPa
Elongation	BS EN ISO 527-1 & 3 – Plastics – determination of tensile properties	> 150%
Initial skid resistance on application	Skid resistance (SRV) by the pendulum method BS EN 13036-4: 2003 using the narrow slider with measurements on scale C	> 60 SRV
Retained skid resistance	Skid resistance (SRV) by the pendulum method BS EN 13036-4 using the narrow slider with measurements on scale C	> 50 SRV
Initial texture depth	Determined by the draft linear sand patch test	> 1.5 mm*
* Not applicable for footways and footpaths.		

A2.6.5 Alternative materials may be proposed for infill of micro trenching. This must be supported by a track record of use and a Product Acceptance Scheme accreditation. Otherwise, materials must follow A9 for approval.

A2.7 Structural layer thickness tolerances

A2.7.1 Several individual layers of material, commonly termed lifts, may be required to reinstate a structural layer.

- A2.7.2 The thickness of each complete structural layer is specified as a nominal value.
- A2.7.3 The lower tolerance for the thickness of a structural layer must be as follows:
- 1) -5 mm for the surface course
 - 2) -10 mm for any other structural layer comprising bound material
 - 3) -20 mm for any other structural layer comprising unbound material
- A2.7.4 There is no upper tolerance for structural layer thickness. However, where large thicknesses of surface course are used:
- 1) the requirements for compacted lift thicknesses under A2.8 must be met as must the in-situ air-voids through the full depth of the as-laid surface course layer, as set out in S10.2.8.
 - 2) the required combined binder and base course material thickness is still required unless the binder course mixture is replaced with surface course mixture, as permitted by A2.0.4 and A2.0.5.
 - 3) the surface profile performance requirements set out in S2.2 must not be exceeded.
- A2.7.5 Any combination of permitted tolerances for the thickness of each structural layer of bituminous or cement bound mixtures must not result in either of the following:
- 1) An overall reduction in thickness of the bound pavement, excluding the sub-base, of more than 15 mm from the specified nominal thickness in a road, subject to an absolute minimum of 100 mm of bound materials. See S6.8.9(2) for an exception to this requirement where only the surface is trimmed.
 - 2) An overall reduction in the thickness of the bound pavement, excluding the sub-base, of more than 10 mm from the specified nominal thickness in a footway, subject to an absolute minimum of 60 mm of bound materials. See S8.6.3 for an exception to this requirement where only the surface is trimmed.
- A2.7.6 If the combined thickness of the relevant layers equals or exceeds that of the Code requirements, then this will not be considered as a non-compliance with the Code provided that each individual lift meets the thickness requirements of Tables A2.5 and A2.6 and the bituminous mixtures meet the void requirements of S10.2.8.

A2.8 Compacted lift thickness

- A2.8.1 The compacted thickness of all individual lifts within all reinstatement structural layers must be in accordance with the following requirements:
- Bituminous mixtures**
- A2.8.2 The compacted thickness of all individual lifts of bituminous mixtures must be in accordance with Table A2.5 when checked in accordance with the destructive method in BS EN 12697-36.

Table A2.5 Compacted lift thickness (mm) – Bituminous mixtures

Material type	PD 6691 reference	Compacted lift thickness (mm)		
		Minimum at any point	Nominal lift thickness	Maximum at any point
6 mm DSC	AC6 dense surf	15	20 – 30	40
10 mm CGSC	AC10 close surf	25	30 – 40	50
15/10 HRA	HRA 15/10 F surf	25	30	50
30/10 HRA	HRA 30/10 F surf	30	35	45
30/14 HRA	HRA 30/14 F surf HRA 30/14 C surf	35	40	50
35/14 HRA	HRA 35/14 F surf HRA 35/14 C surf	40	45 - 50	60
55/14 HRA	HRA 55/14 F surf	40	45	55
55/10 HRA	HRA 55/10 F surf	35	40	50
6 mm SMA	SMA 6 surf	15	20 - 40	45
10 mm SMA	SMA 10 surf	20	25 - 50	55
14 mm SMA	SMA 14 surf	30	35 - 50	55
10 mm PA	PA 10*	25*	30 – 35*	40*
20 mm PA	PA 20*	40*	45 – 60*	65*
50/14 HRA	HRA 50/14 F bin	30	35 - 65	85
50/20 HRA BC	HRA 50/20 bin	40	45 - 80	100
60/20 HRA BC	HRA 60/20 bin	40	45 - 80	100
14 mm SMA BC	SMA 14 bin	25	30 - 60	65
20 mm SMA BC	SMA 20 bin	40	50 - 100	110
14 mm DBC	-	35	40 - 70	80
20 mm DBC	AC20 dense bin	40	50 - 100	110

Notes:

The binder course thickness must be adjusted accordingly to the thickness of the surface course to comply with the requirements in appendices A3 to A7.

* The use of Porous Asphalt (PA) is limited in the UK except for specialist uses such as sustainable drainage systems. Where porous asphalt surfaces are encountered refer to S6.4.13 (BS EN 13108-7 contains specifications for this group of asphalts and guidance on the appropriate material should be obtained from the authority).

** 14 mm DBC is not currently included in PD 6691. It should be referenced as AC14 dense bin.

Non-bituminous materials

A2.8.3 The compacted thickness of all individual lifts of non-bituminous materials must be in accordance with Table A2.6.

Table A2.6 Compacted lift thickness – Non-bituminous materials

Material	Compacted lift thickness (mm)		
	Minimum at any point	Nominal lift thickness	Maximum at any point
CBGM base	100	120 to 150	200
C25/30 concrete	100	As required	As existing
C32/40 concrete	100	As required	As existing
GSB1	75	100 to 150	200
Classes A & B	75	100 to 150	200
Classes C & D	75	100 to 150	200
SMF-A & SMF-B	75	100 to 150	200
SMF-C & SMF-D	75	100 to 150	200

A2.9 Bituminous laying temperatures

A2.9.1 The laying temperatures for bituminous mixtures must be in accordance with Table A2.7.

Table A2.7 Laying temperatures– Bituminous materials				
Material	Binder grade	Maximum temperature at any stage (°C)	Minimum temperatures (°C)	
			Arrival *	Minimum rolling #
CGSC	100/150	170	120	95
DSC	160/220	170	110	85
DBC	40/60	190	130	100
	70/100	180	125	95
	100/150	170	120	90
	160/220	170	110	80
HRA SC#	40/60	190	140	110
	70/100	180	125	90
	100/150	170	120	85
HRA BC	40/60	190	130	105
	70/100	180	125	90
	100/150	170	120	85
SMA SC SMA BC	40/60	200	130	100
	70/100	180	125	90
	100/150	170	120	85
Porous Asphalt	125	135	110	85
	190	145		

Notes:
1 * = In the lorry within 30 minutes after arrival on site.
2 For coated slag mixtures temperatures may be 10°C lower than the recommended values.
3 # = See Table A2.8 for the final rolling temperatures when chippings are applied to HRA surface courses.
4 To achieve acceptable air voids, most materials will require greater compactive effort as the temperature approaches the lower limit. Additives are available which can be used to assist compaction at lower temperatures

Table A2.8 Final rolling temperatures - HRA	
Binder grade	Minimum temperature (°C) at completion of rolling
40/60	85
70/100	80
100/150	75

Note: When using modified bitumen or additives, different temperatures might be applicable.

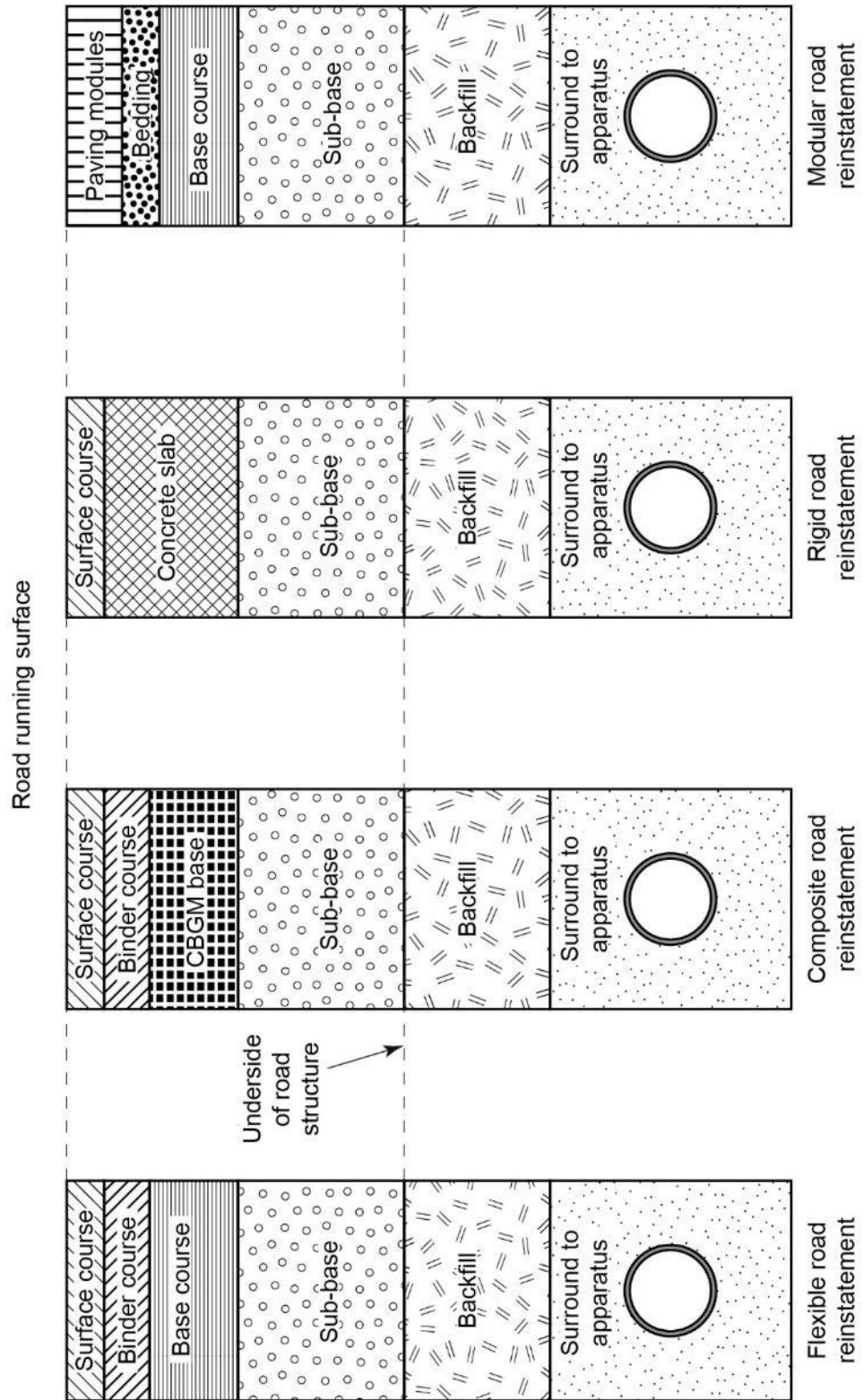
A2.10 Identification of structural layers

Road structures

- A2.10.1 For the purposes of defining permissible material options, layer thickness etc., this Code classifies road structures as being of flexible, composite,

rigid or modular design. Road structures assumed to be representative of each of these designs are shown in Figure A2.1. For each design, a typical reinstatement structure identifying the principal structural layers is also shown.

Figure A2.1 Typical reinstatement structure within recognised road designs



A2.10.2 Permitted materials and layer thickness for road structures are specified as follows:

- 1) Flexible design – see Figures A3.1 to A3.5
- 2) Flexible sub-structure – see Figure A3.6
- 3) Composite design – see Figures A4.1 to A4.4
- 4) Composite sub-structure – see Figures A4.5 to A4.6
- 5) Rigid design – see Figures A5.1 to A5.3
- 6) Modular design – see Figures A6.1 to A6.3

A2.10.3 All layer thicknesses are in millimetres.

Footway, footpath and cycle track structures

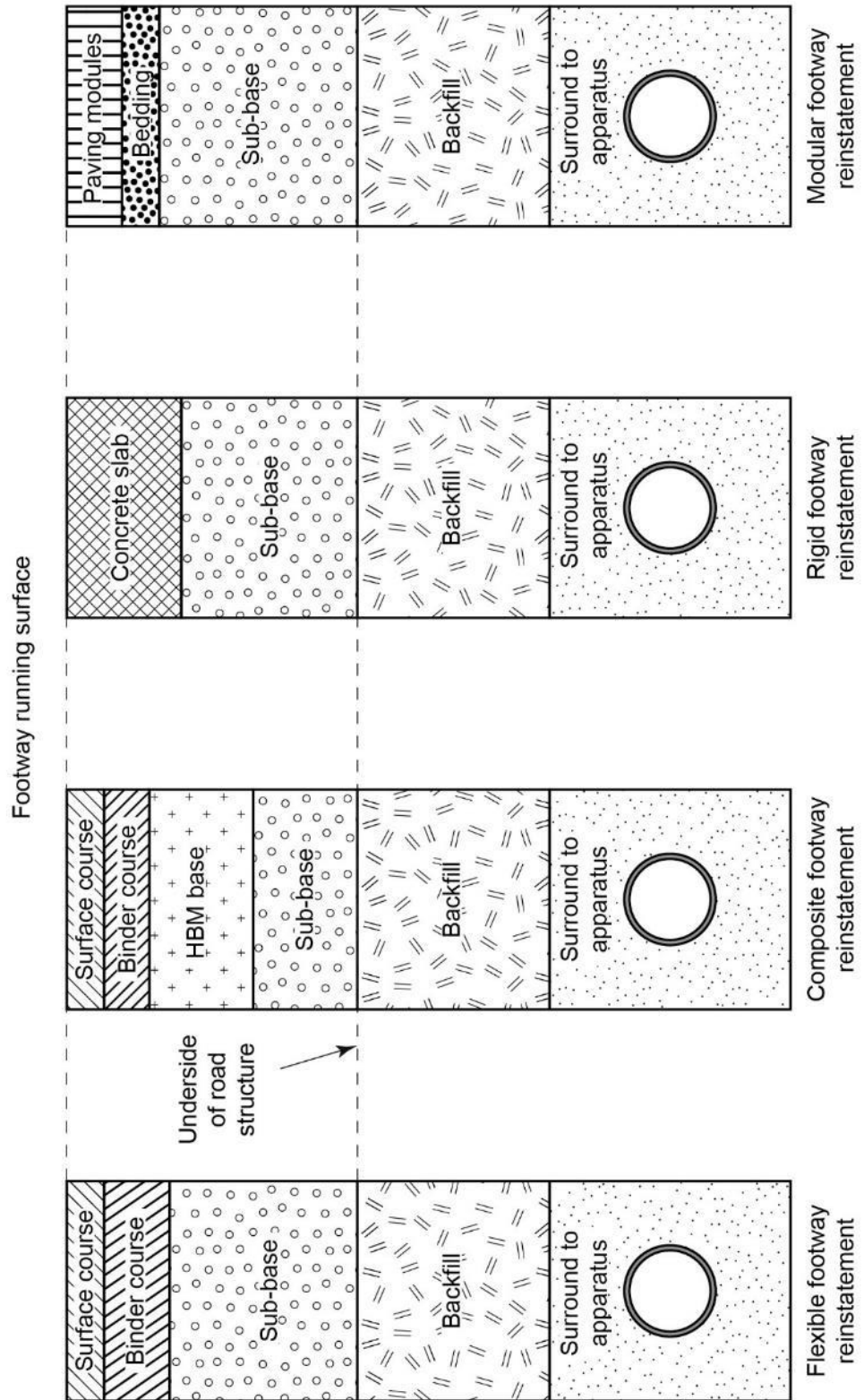
A2.10.4 Footway, footpath and cycle track structures are classified as flexible, composite, rigid or modular. Structures assumed to be representative of each are shown in Figure A2.2, including typical reinstatements, identifying the principal structural layers.

A2.10.5 Permitted materials and layer thickness for footway, footpath and cycle track structures are specified in:

- 1) Figure A7.1 for flexible;
- 2) Figure A7.2 for composite structures;
- 3) Figure A7.3 for rigid structures; and
- 4) Figure A7.4 for modular structures.

A2.10.6 All layer thicknesses are in millimetres.

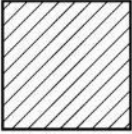

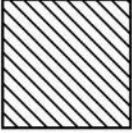

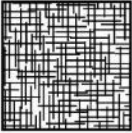




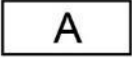



Figure A2.2 Typical reinstatement structure within recognised footway designs



A2.11 Key to materials

- A2.11.1 For the purposes of defining the main material options, layer thickness, etc. required by this Code, A3 to A7 inclusive show the principal structural layers within cross-sections of typical reinstatement designs in each of the main surface categories. Materials are denoted by the symbols in Table A2.9.
- A2.11.2 Proprietary asphalt materials are not included in Table A2.9, given their specialist and limited application, an example being PMMA which may be used in footway surface courses and access surrounds to larger apparatus in roads. PMMA must comply with the requirements of A2.5.1 and A2.5.2.
- A2.11.3 ARMs are not shown, given the wide range of options and material variations.

Table A2.9 Key to reinstatement materials

 <p>HRASC ACCSC SMASC</p>  <p>HRASC ACCSC ACDSC SMASC PCSC</p>	<p>HRASC - Hot Rolled Asphalt Surface Course See A2.1.1</p> <p>ACCSC - Asphalt Concrete Close Surface Course See A2.3.1</p> <p>ACDSC - Asphalt Concrete Dense Surface Course See A2.3.1</p> <p>SMASC - Stone Mastic Asphalt Surface Course See A2.2.1</p> <p>PCSC - Permanent Cold-lay Surface Course See A2.4.1</p>
 <p>HRABC ACBC SMABC</p>  <p>HRABC ACBC SMABC PCBC</p>	<p>HRABC - Hot Rolled Asphalt Binder Course See A2.1.2</p> <p>ACBC - Asphalt Concrete Binder Course See A2.3.2</p> <p>SMABC - Stone Mastic Asphalt Binder Course See A2.2.2</p> <p>PCBC - Permanent Cold-lay Binder Course See A2.4.1</p>
 <p>DSM PCSM</p>	<p>DSM - Deferred Set Mixtures See A2.4.2</p> <p>PCSM - Permanent Cold-lay Surfacing Material See A2.4.1</p>
 <p>Concrete</p>	<p>Concrete - Pavement Quality Concrete To SHW Clause 1001</p>
 <p>CBGM base</p>	<p>CBGM base - Cement Bound Granular Mixture See S6.3.3</p>
 <p>HBM</p>	<p>HBM - Hydraulically Bound Materials See A10.2</p>
 <p>GSB 1</p>	<p>GSB 1 - Type 1 unbound mixture or modified type 1 unbound mixture See A10.1</p>
 <p>Class A</p>	<p>Class A - Graded granular backfill material See A1.1</p>
 <p>Class B</p>	<p>Class B - Granular backfill material See A1.1</p>
 <p>Class C</p>	<p>Class C - Cohesive granular backfill material See A1.1</p>
 <p>Class D</p>	<p>Class D - Cohesive backfill material See A1.1</p>

A2.12 Key to reinstatement methods

- A2.12.1 S6.1, S7.1 and S8.1 set out the permissible reinstatement methods for all the main types of construction categories covered by the Code. A3 to A7, inclusive, indicate different materials and material thicknesses for each permissible reinstatement method, which may also vary between different road categories. Table A2.10 summarises these permissible reinstatement methods.

Table A2.10 Key to reinstatement methods

Reinstatement method (at first visit)	Flexible & composite roads S6		Rigid & modular roads S7			Footways, footpaths & cycle tracks S8		
	Flexible (A3.0 - A3.4 incl.)	Composite (A4.0 - A4.3 incl.)	Rigid (A5.0 - A5.2 incl.)	Modular		Flexible and composite (A7.1 and A7.2)	Rigid (A7.3)	Modular (A7.4)
All permanent	Method A (Types 0-4 incl.)	Method A (Types 0-4 incl.)	Method A (Types 0-4 incl.)	Method A (A6.1)	Method A (Composite base (roadbase) (A6.2))	Method A (Granular base (roadbase) (A6.3))	Method A	Method A
Interim with permanent binder course	Method B (Types 0-4 incl.)	Method B (Types 0-4 incl.)	N/A	N/A	N/A	N/A	Method B	N/A
Interim with permanent base	Method C (Types 3, 4 incl.)	Method C (Types 0-4 incl.)	N/A	N/A	N/A	N/A	N/A	N/A
Interim with permanent sub-base	Method D (Types 0-4 incl.)	Method D (Types 0-4 incl.)	Method D (Types 0-4 incl.)	Method D (Types 3, 4 only)	Method D (Types 3, 4 only)	Method D (Types 3, 4 only)	Method D	Method D
Permanent incorporating interim surface overlay	N/A	N/A	Method E (Types 0-4 incl.)	N/A	N/A	N/A	N/A	N/A

A2.13 Summarised selection process for hot lay flexible materials

- A2.13.1 Specific to the hot-lay reinstatement of flexible roads and footways (including footpaths and cycle tracks), different parts of the Code set out the following criteria:
- 1) overall class, layer designation and mixture design for HRA, SMA and AC (A2.1 to A2.3);
 - 2) different thicknesses of mixture layers (A3 and A7);
 - 3) specific requirements and limitations for surface courses (S6.4 and S8.3).
- A2.13.2 The overall process for selecting the correct materials to reinstate flexible roads and footways is particularly complex at the reinstatement design selection stage. Figure S0.1 provides a generic overview of this process, but to assist practitioners, Figures A2.3, A2.4 and A2.5 respectively set out the summarised overall processes specific to:
- 1) Types 0 and 1 flexible roads
 - 2) Types 2, 3 and 4 flexible roads
 - 3) Flexible footways, footpaths and cycle tracks

Figure A2.3 Permanent reinstatement options for hot lay flexible materials (roads types 0 and 1)

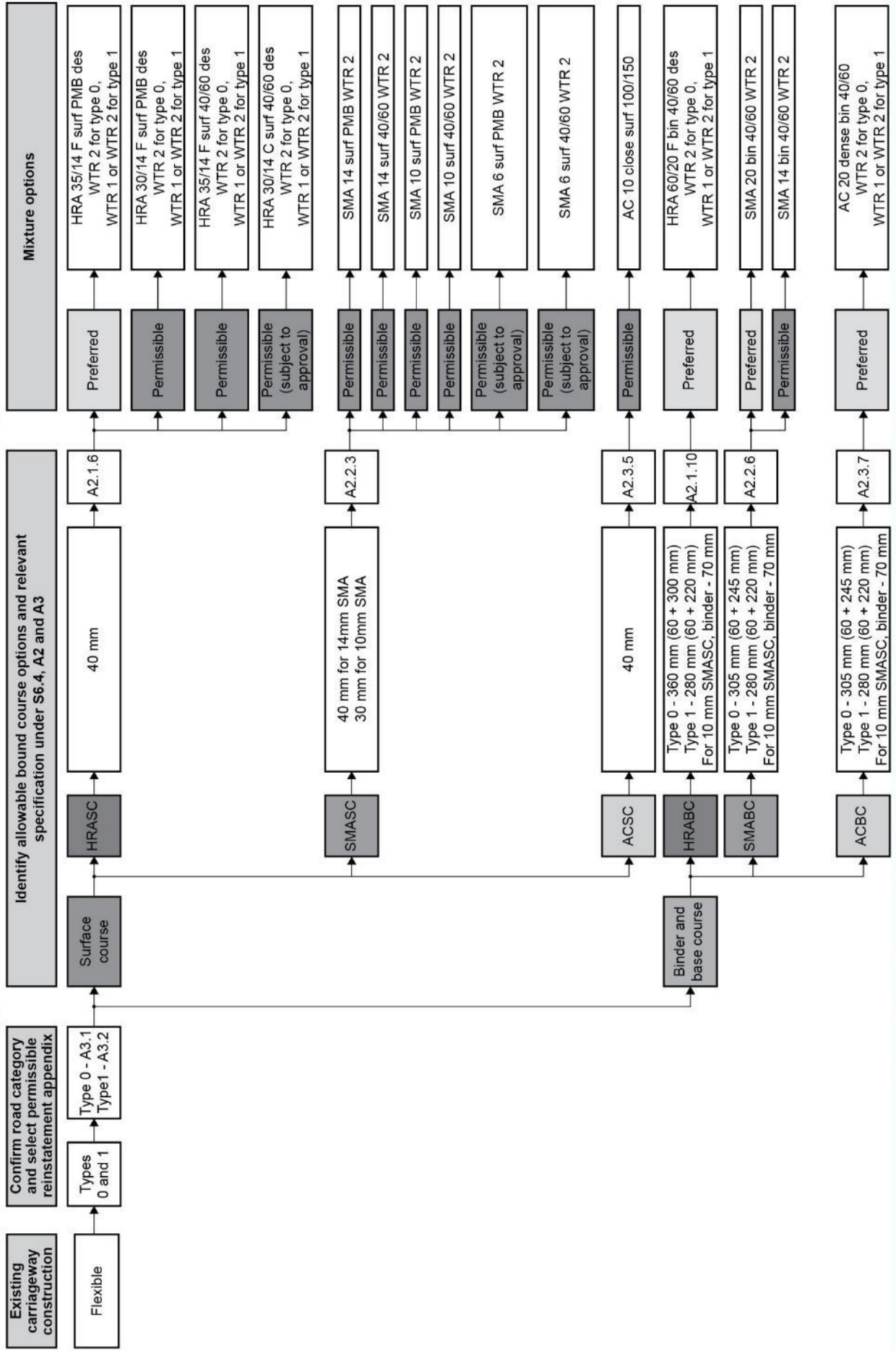


Figure A2.4 Permanent reinstatement options for hot lay flexible materials (road types 2, 3 and 4)

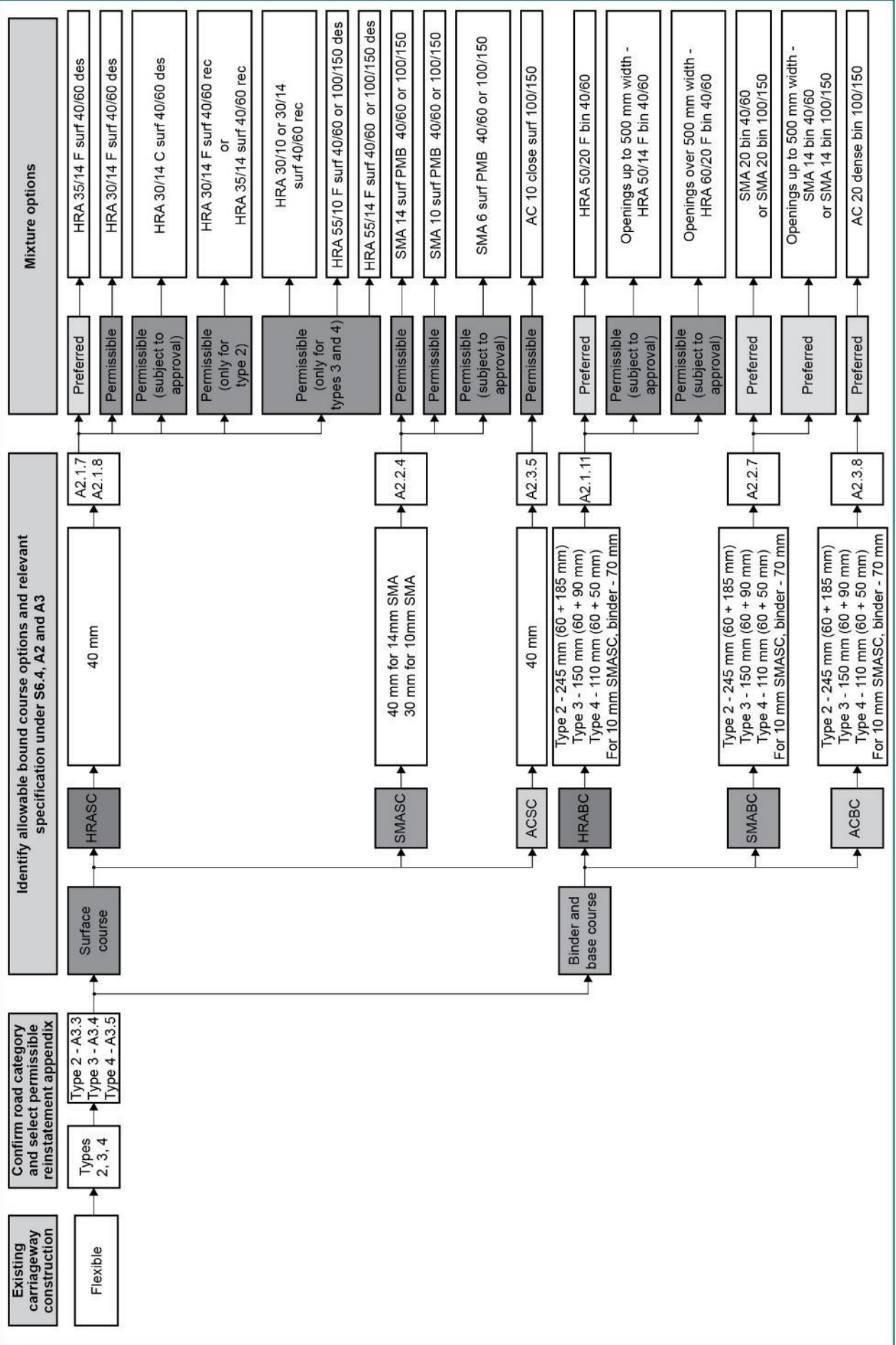
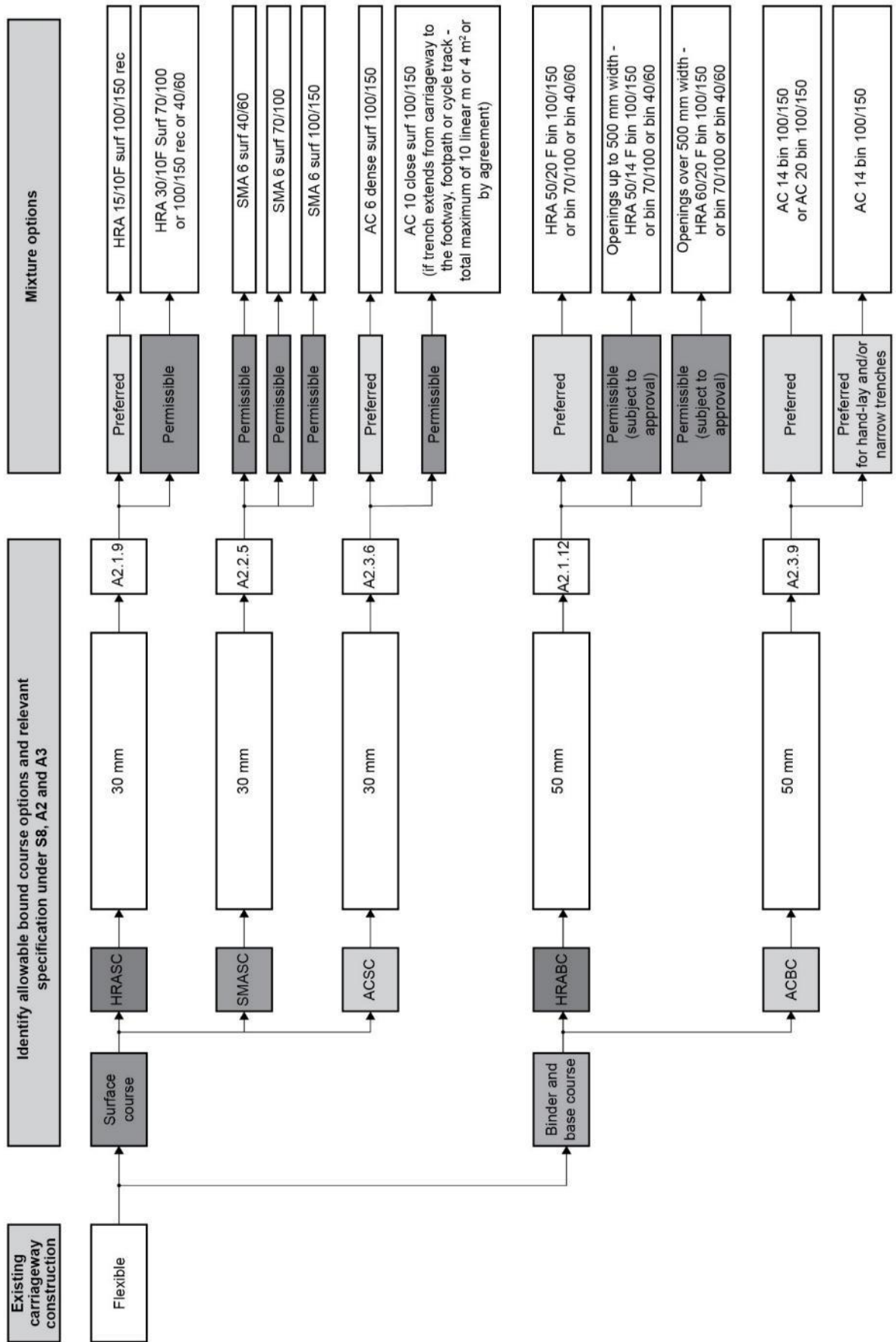


Figure A2.5 Permanent reinstatement options for hot lay flexible materials (footways, footpaths and cycle tracks)



Appendix A3 Flexible roads

Figure A3.1 Flexible roads type 0

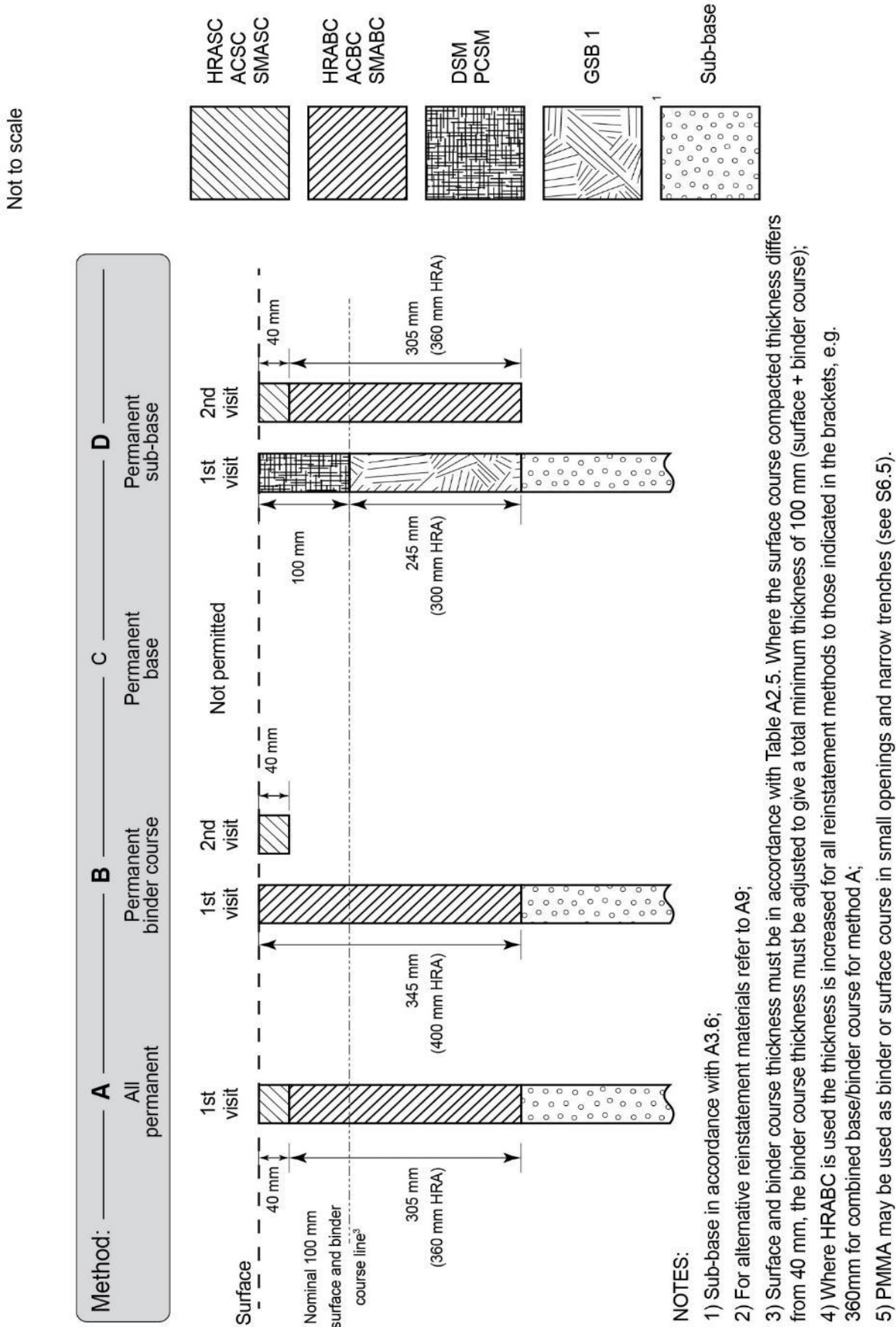
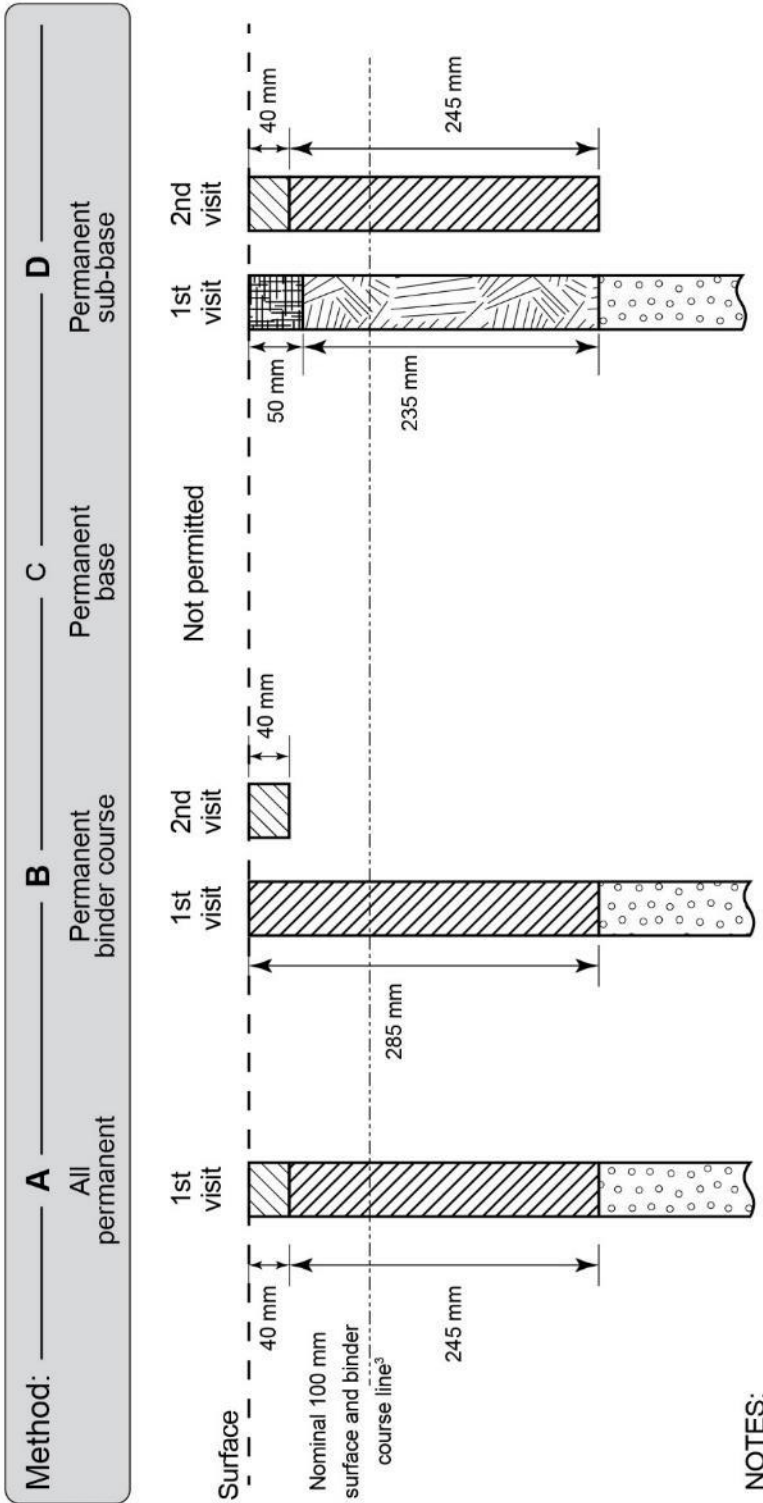


Figure A3.3 Flexible roads type 2

Not to scale



NOTES:

- 1) Sub-base in accordance with A3.6;
- 2) For alternative reinstatement materials refer to A9;
- 3) Surface and binder course thickness must be in accordance with Table A2.5. Where the surface course compacted thickness differs from 40 mm, the binder course thickness must be adjusted to give a total minimum thickness of 100 mm (surface + binder course);
- 4) Where a road has been constructed, by the authority, to HD 26 design standards, and informs the undertaker accordingly, the total asphalt thickness shall be increased to 320 mm (assuming 100/150 pen) by the use of additional binder course material;
- 5) PMMA may be used as binder or surface course in small openings and narrow trenches (see S6.5);
- 6) HBM and FCR can be used as combined sub-base and base with a minimum total asphalt overlay of 100 mm. See Tables A10.6 and A2.1, respectively.

Figure A3.4 Flexible roads type 3

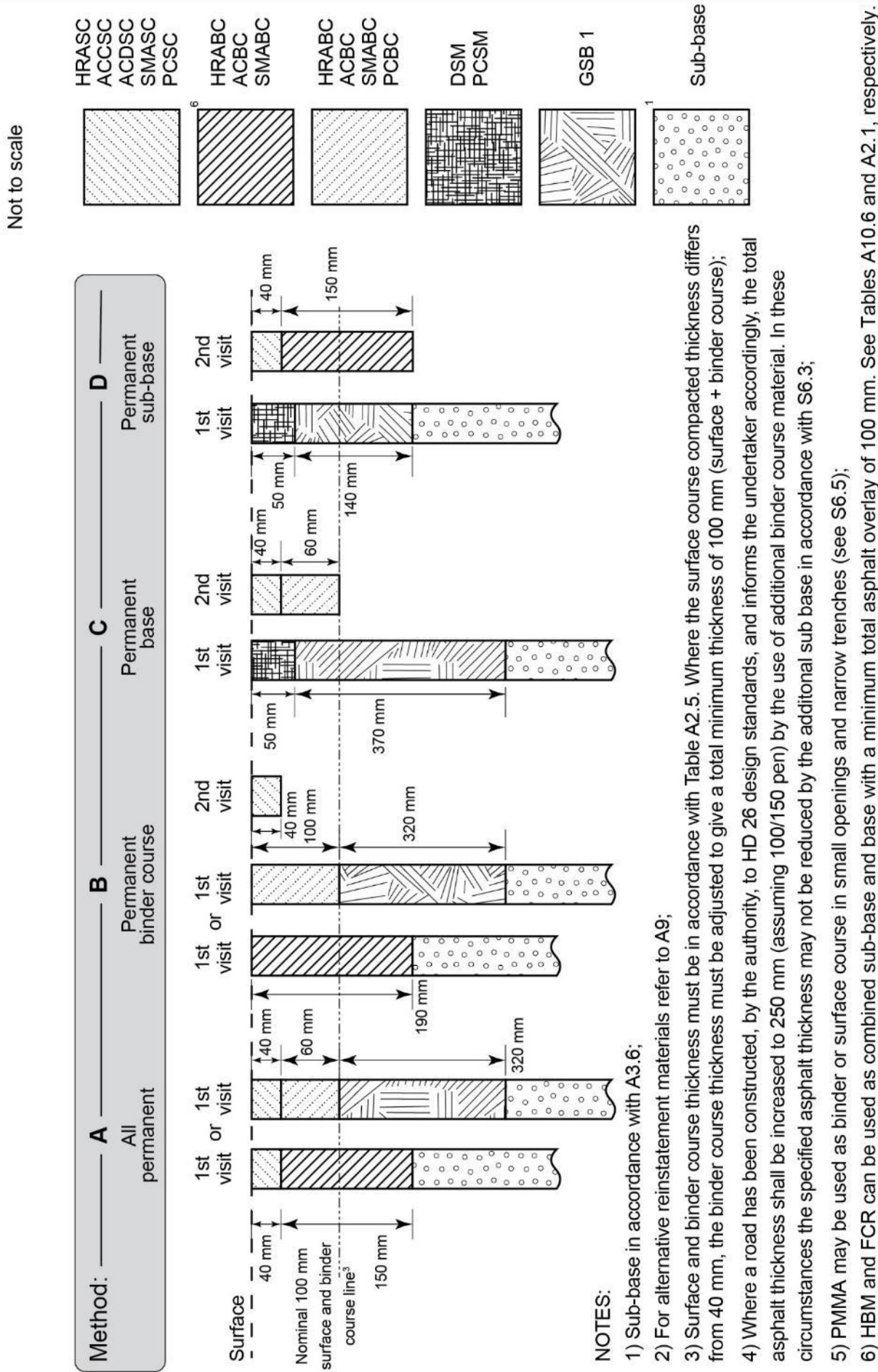
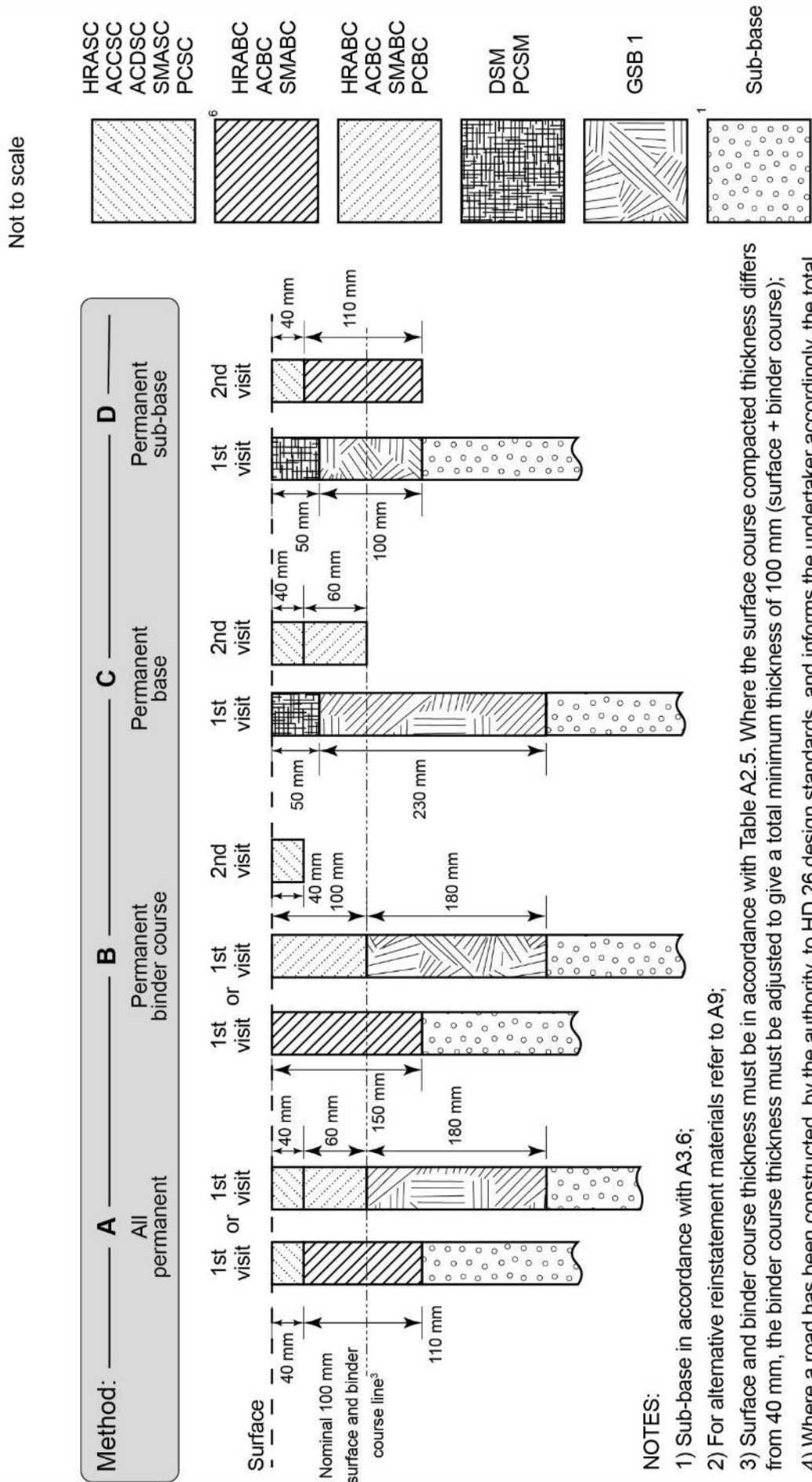


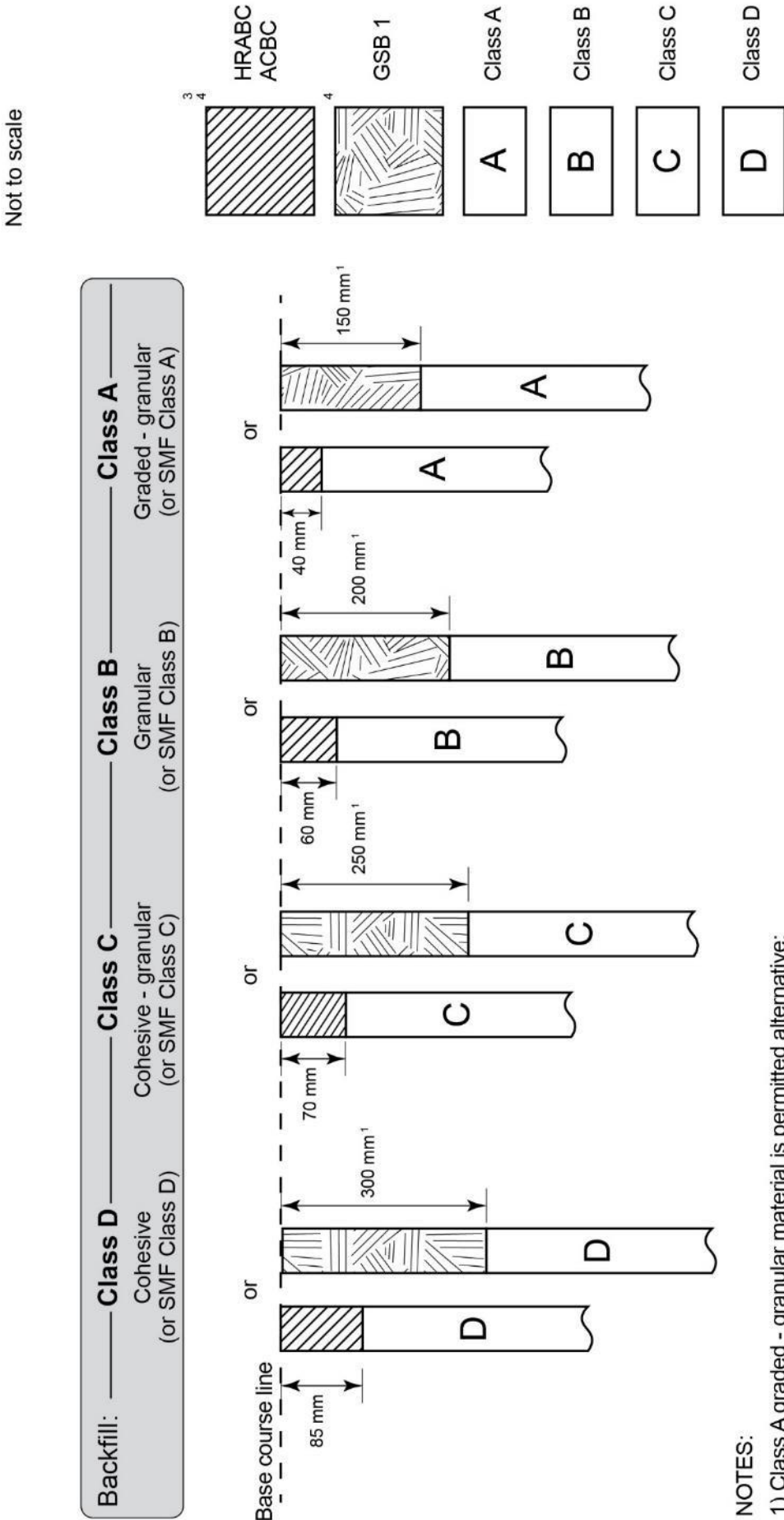
Figure A3.5 Flexible roads type 4



NOTES:

- 1) Sub-base in accordance with A3.6;
- 2) For alternative reinstatement materials refer to A9;
- 3) Surface and binder course thickness must be in accordance with Table A2.5. Where the surface course compacted thickness differs from 40 mm, the binder course thickness must be adjusted to give a total minimum thickness of 100 mm (surface + binder course);
- 4) Where a road has been constructed, by the authority, to HD 26 design standards, and informs the undertaker accordingly, the total asphalt thickness shall be increased to 250 mm (assuming 100/150 pen) by the use of additional binder course material. In these circumstances the specified asphalt thickness may not be reduced by the additional sub base in accordance with S6.3;
- 5) PMMA may be used as binder or surface course in small openings and narrow trenches (see S6.5);
- 6) HBM and FCR can be used as combined sub-base and base with a minimum total asphalt overlay of 100 mm. See Tables A10.6 and A2.1, respectively.

Figure A3.6 Sub-base construction for flexible roads



NOTES:

- 1) Class A graded - granular material is permitted alternative;
- 2) In addition to SMF classes A to D, for other alternative reinstatement materials refer to A9;
- 3) PMMA may be used as sub-base in small openings and narrow trenches (see S6.5);
- 4) HBM and FCR can be used as combined sub-base and base with a minimum total asphalt overlay of 100 mm. See Tables A10.6 and A2.1, respectively.

Appendix A4 Composite roads

Figure A4.1 Composite roads type 0

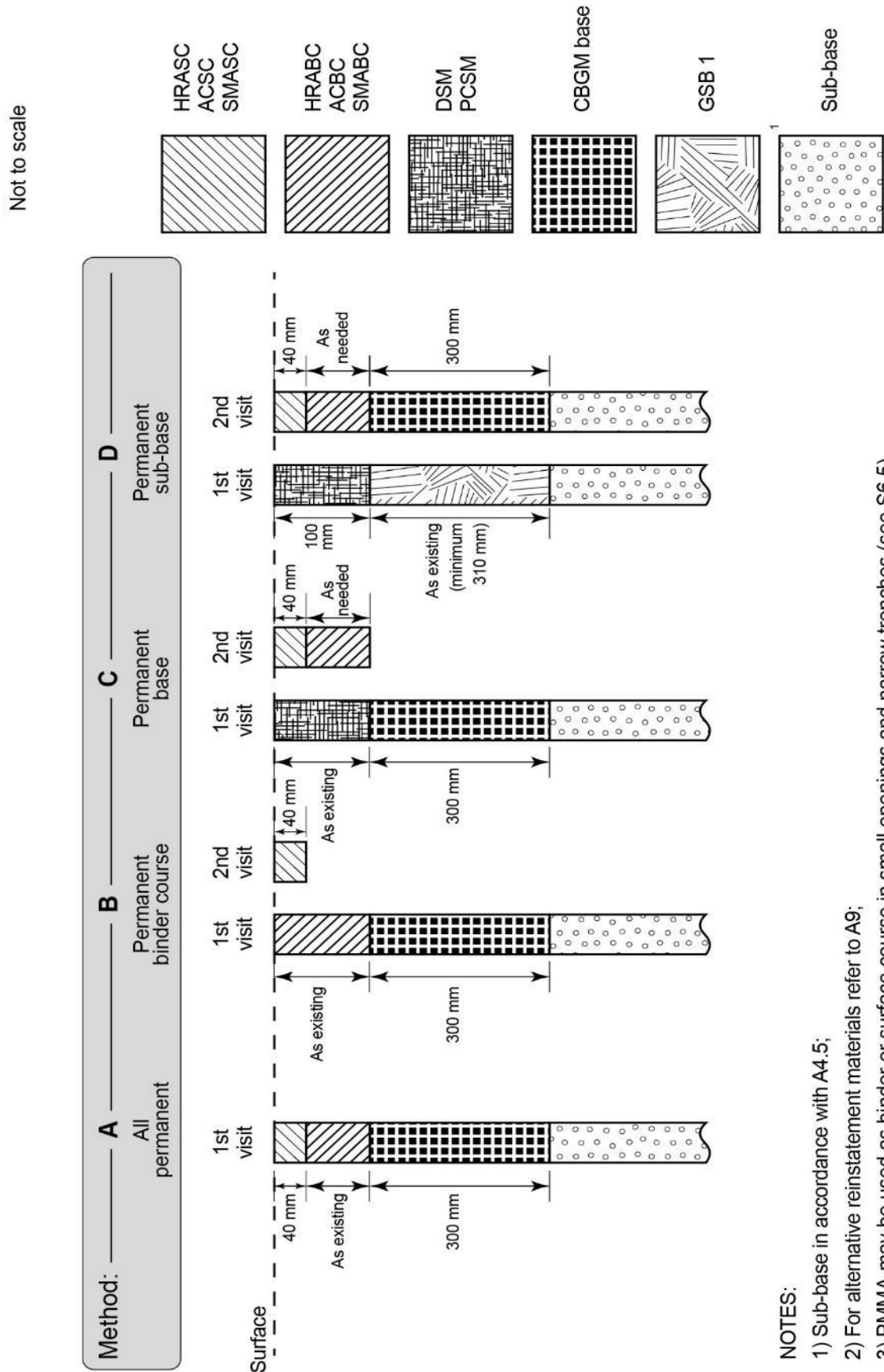
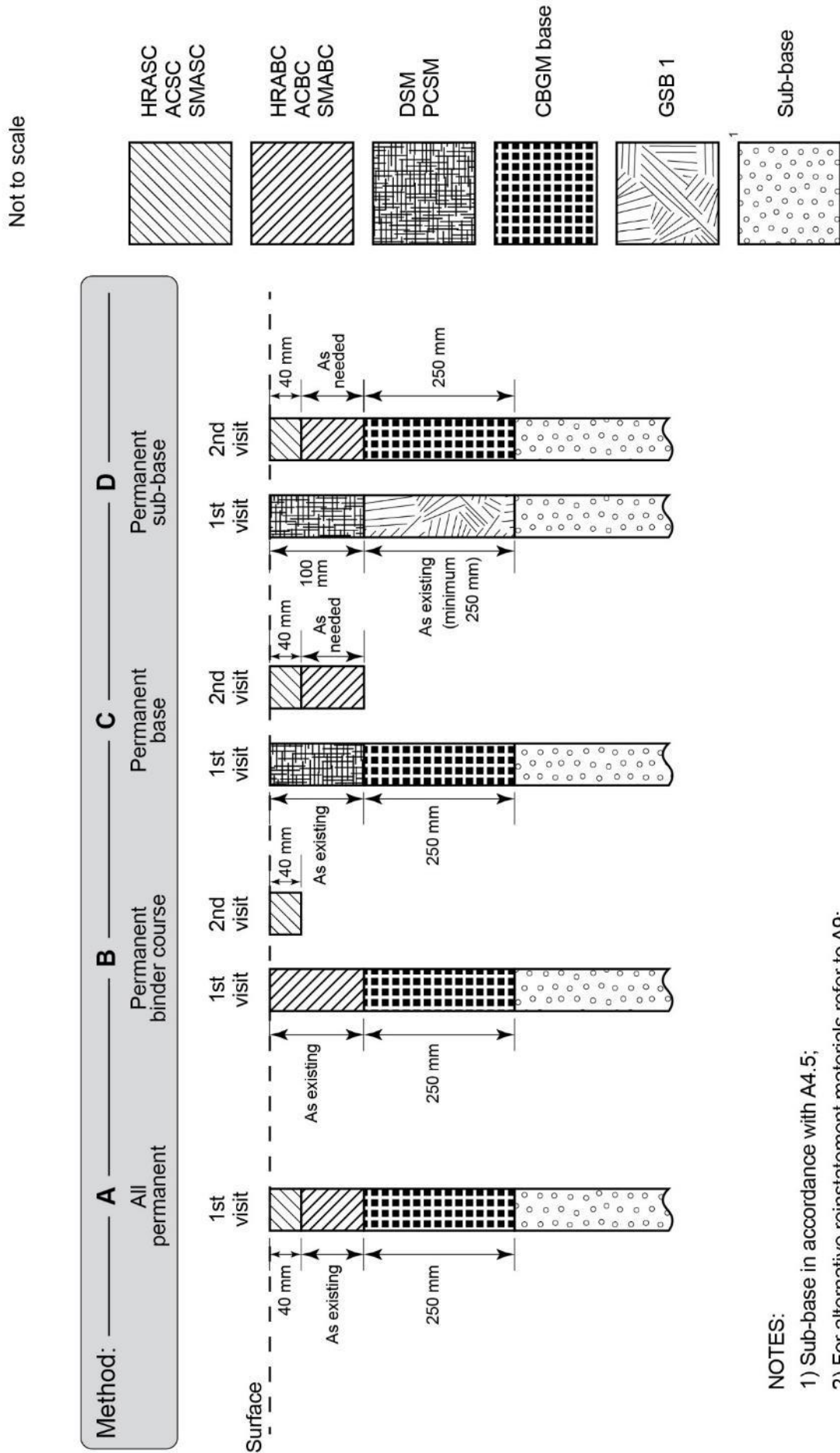


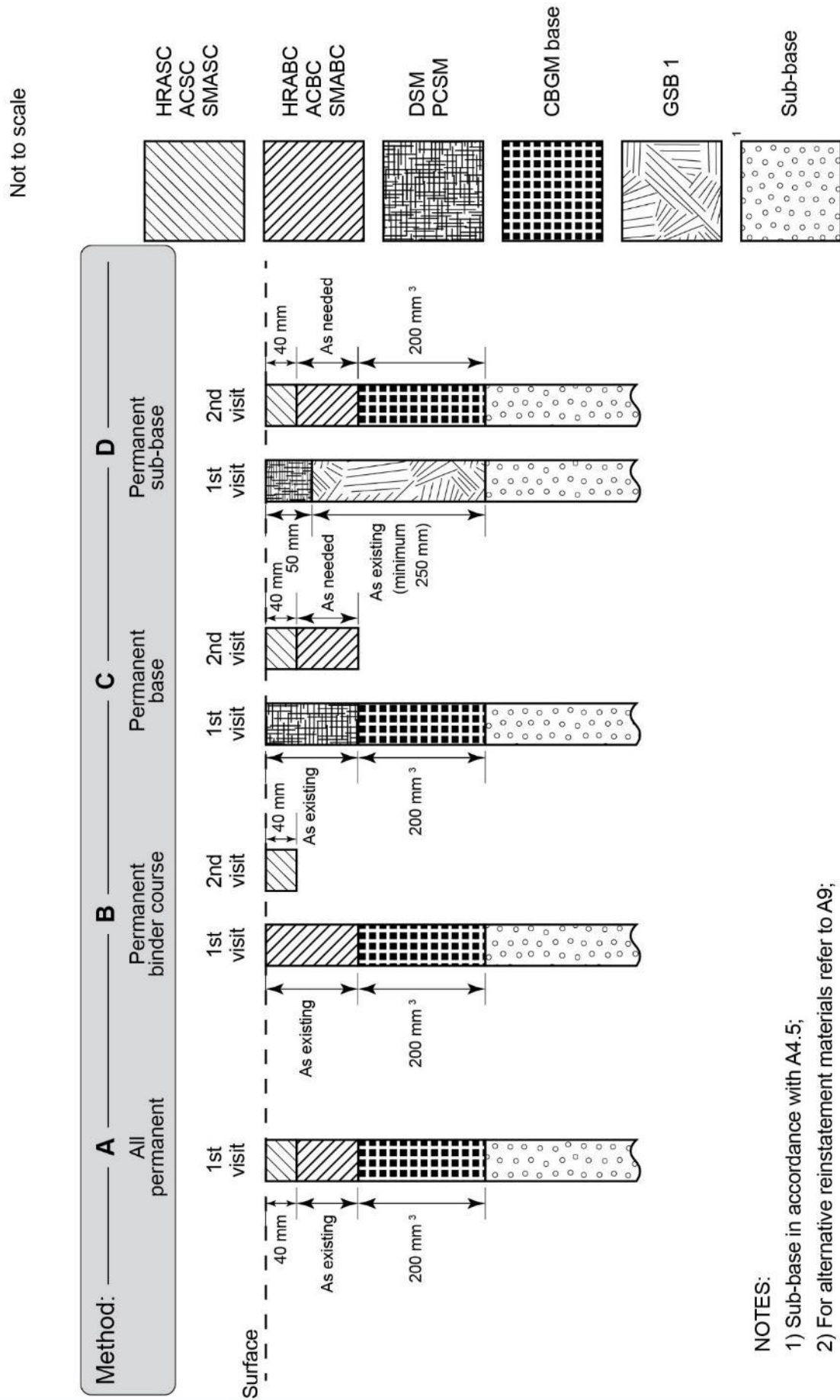
Figure A4.2 Composite roads type 1



NOTES:

- 1) Sub-base in accordance with A4.5;
- 2) For alternative reinstatement materials refer to A9;
- 3) PMMA may be used as binder or surface course in small openings and narrow trenches (see S6.5).

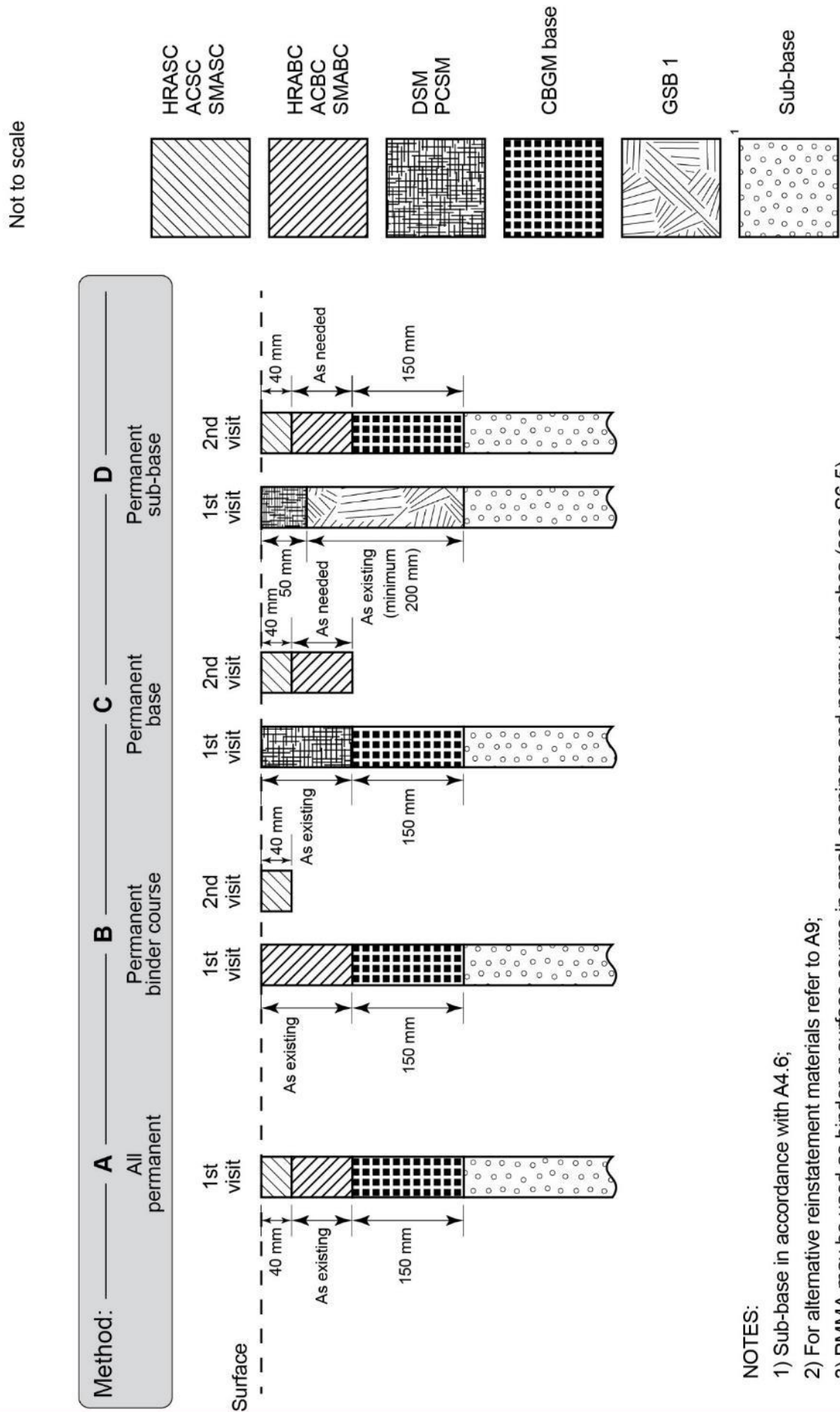
Figure A4.3 Composite roads type 2



NOTES:

- 1) Sub-base in accordance with A4.5;
- 2) For alternative reinstatement materials refer to A9;
- 3) Roadbase to be 250 mm thick if existing exceeds 200 mm;
- 4) PMMA may be used as binder or surface course in small openings and narrow trenches (see S6.5).

Figure A4.4 Composite roads types 3 and 4

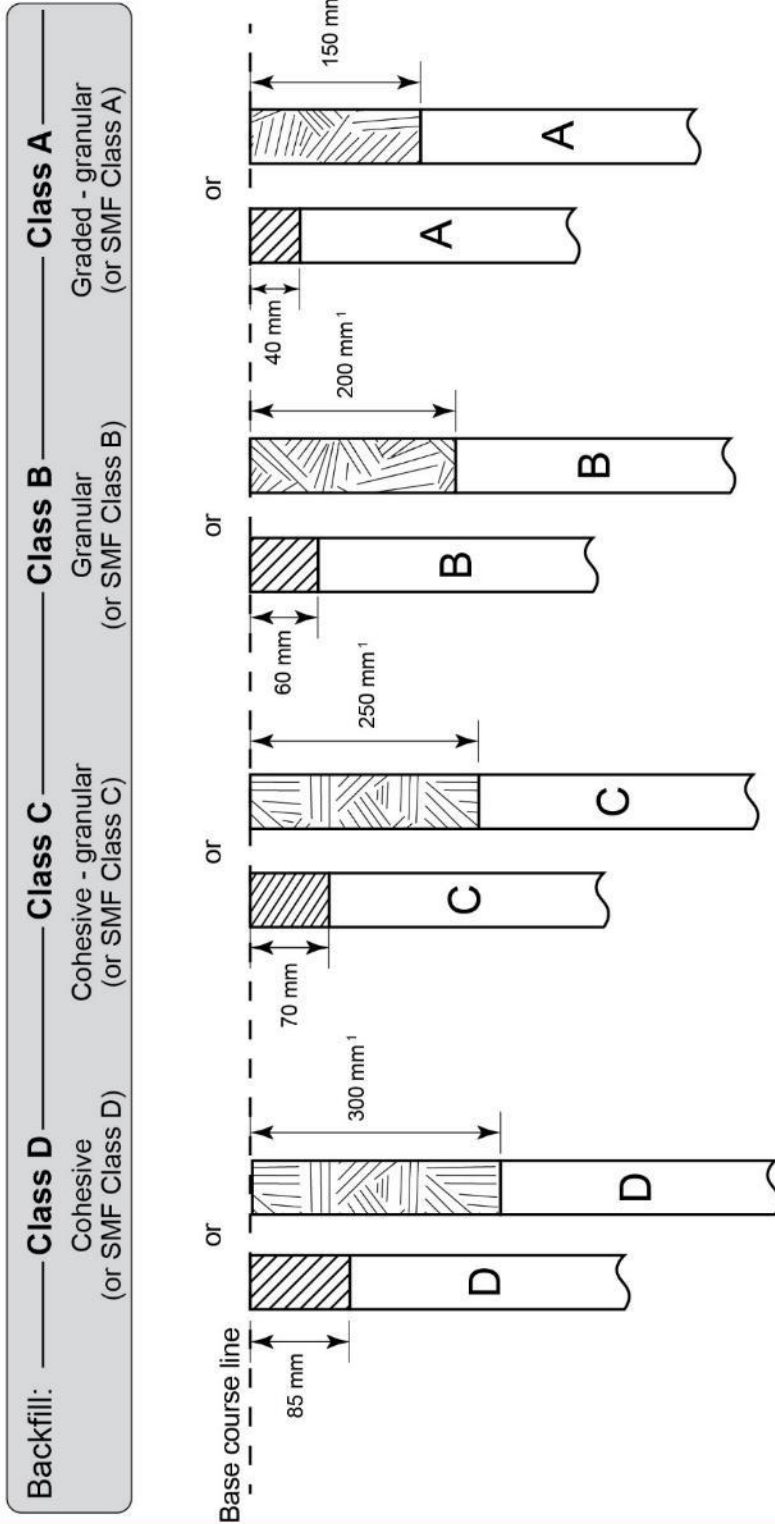


NOTES:

- 1) Sub-base in accordance with A4.6;
- 2) For alternative reinstatement materials refer to A9;
- 3) PMMA may be used as binder or surface course in small openings and narrow trenches (see S6.5).

Figure A4.5 Sub-base construction for composite roads - types 0, 1 and 2

Not to scale

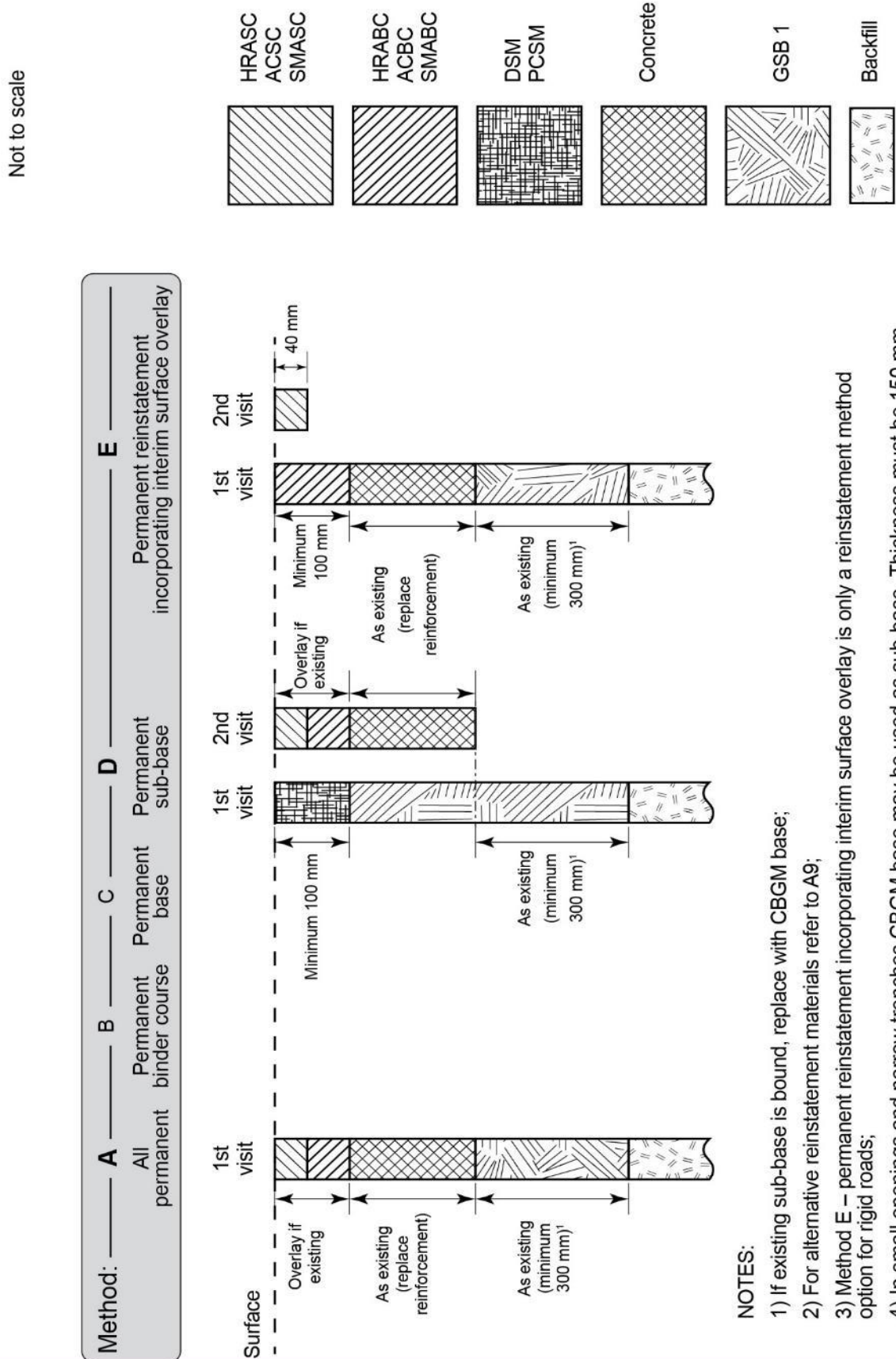


NOTES:

- 1) Class A graded - granular material is permitted alternative;
- 2) In addition to SMF classes A to D, for other alternative reinstatement materials refer to A9;
- 3) PMMA may be used as sub-base in small openings and narrow trenches (see S6.5);
- 4) In small openings and narrow trenches CBGM base may be used as sub-base. Thickness must be 150 mm and the base must be bound;
- 5) HBM and FCR can be used as combined sub-base and base with a minimum total asphalt overlay of 100 mm. See Tables A10.6 and A2.1, respectively.

Appendix A5 Rigid roads

Figure A5.1 Rigid roads type 0

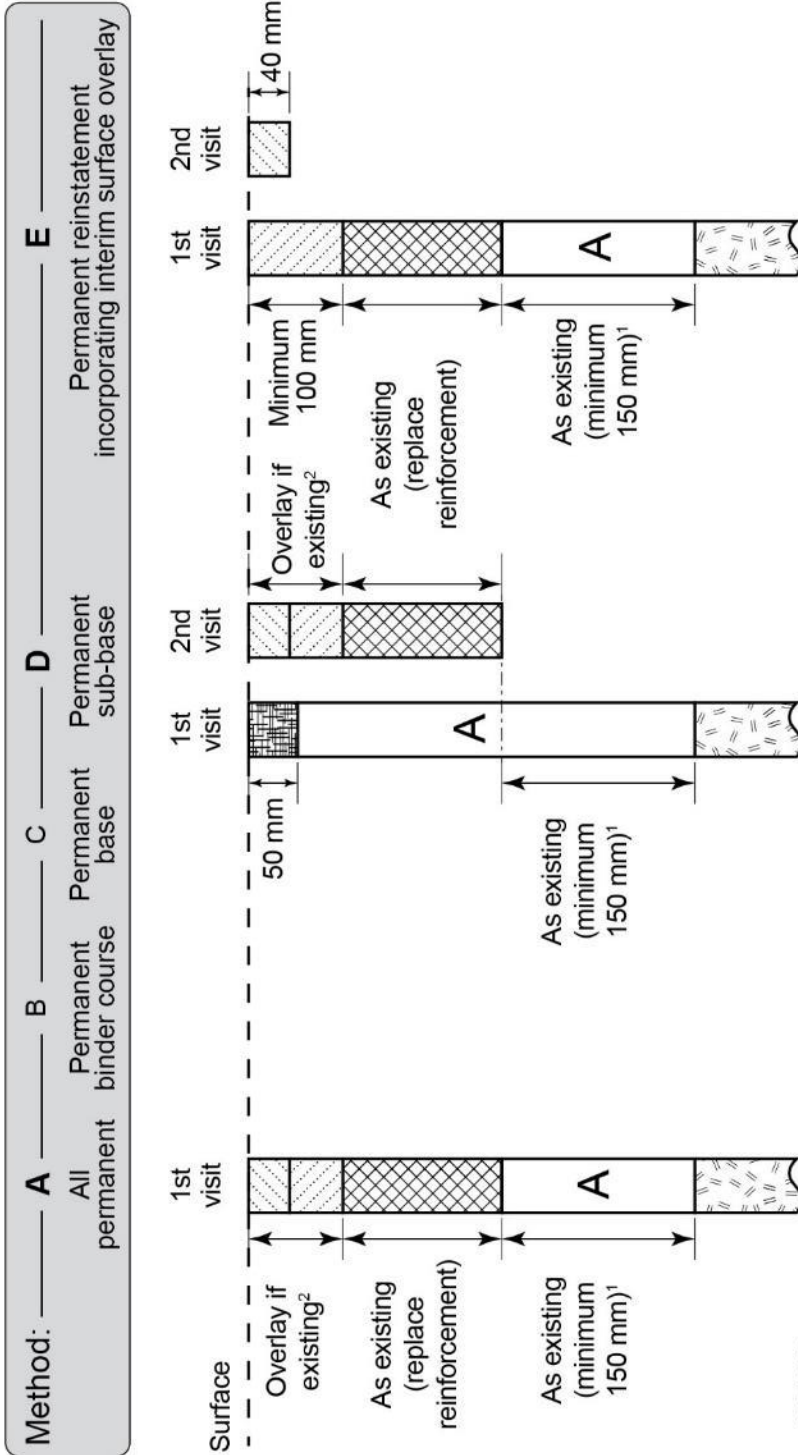


NOTES:

- 1) If existing sub-base is bound, replace with CBGM base;
- 2) For alternative reinstatement materials refer to A9;
- 3) Method E – permanent reinstatement incorporating interim surface overlay is only a reinstatement method option for rigid roads;
- 4) In small openings and narrow trenches CBGM base may be used as sub-base. Thickness must be 150 mm and the base must be bound.

Figure A5.3 Rigid roads types 2, 3 and 4

Not to scale



NOTES:

- 1) If existing sub-base is bound, replace with CBGM base;
- 2) PCSC and PCBC not permitted in type 2 roads;
- 3) For alternative reinstatement materials refer to A9;
- 4) Method E – permanent reinstatement incorporating interim surface overlay is only a reinstatement method option for rigid roads;
- 5) In small openings and narrow trenches CBGM base may be used as sub-base. Thickness must be 150 mm and the base must be bound.

Appendix A6 Modular roads

Figure A6.1 Modular roads (bituminous base) types 3 and 4

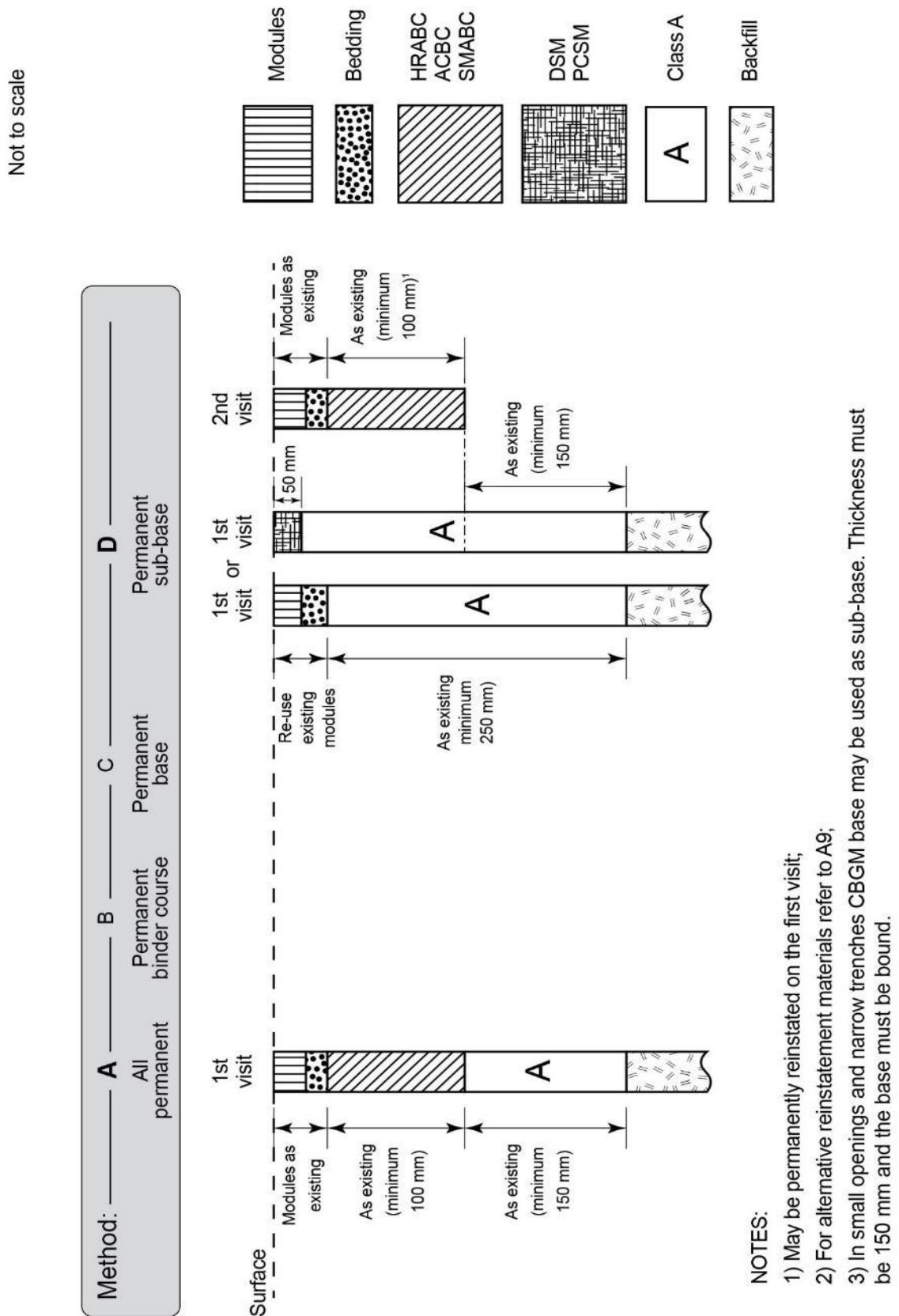
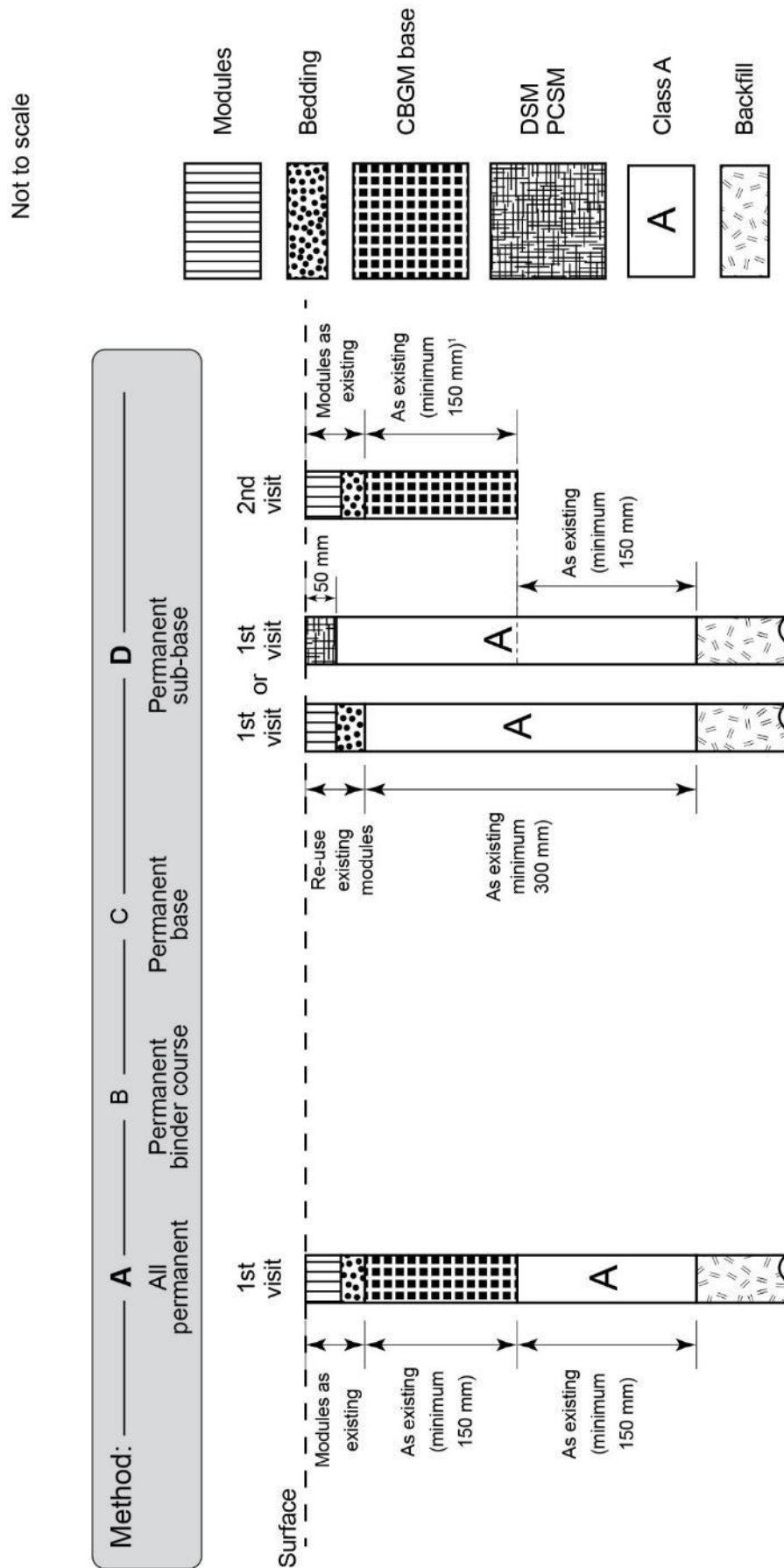


Figure A6.2 Modular roads (composite base) types 3 and 4

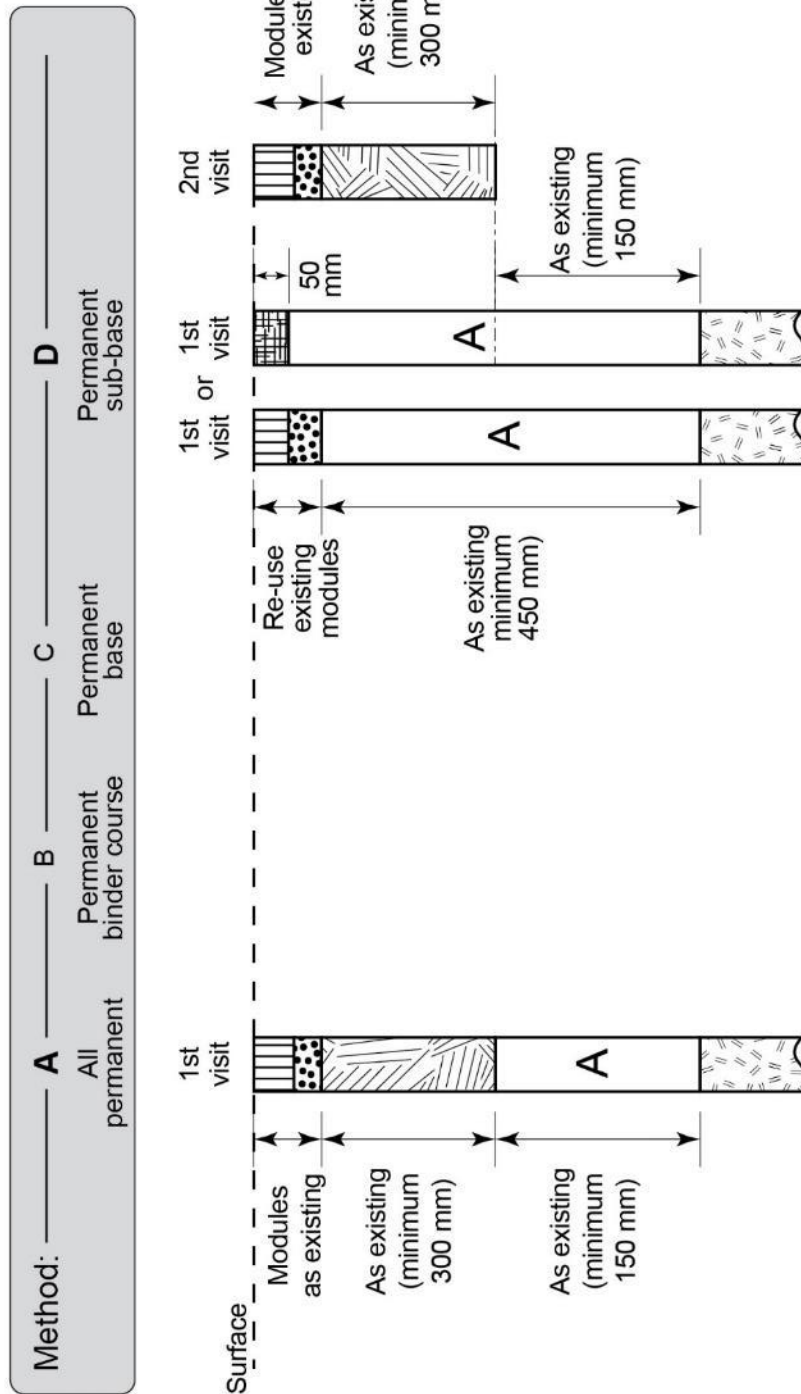


NOTES:

- 1) May be permanently reinstated on the first visit;
- 2) For alternative reinstatement materials refer to A9;
- 3) In small openings and narrow trenches CBGM base may be used as sub-base. Thickness must be 150 mm and the base must be bound.

Figure A6.3 Modular roads (granular base) types 3 and 4

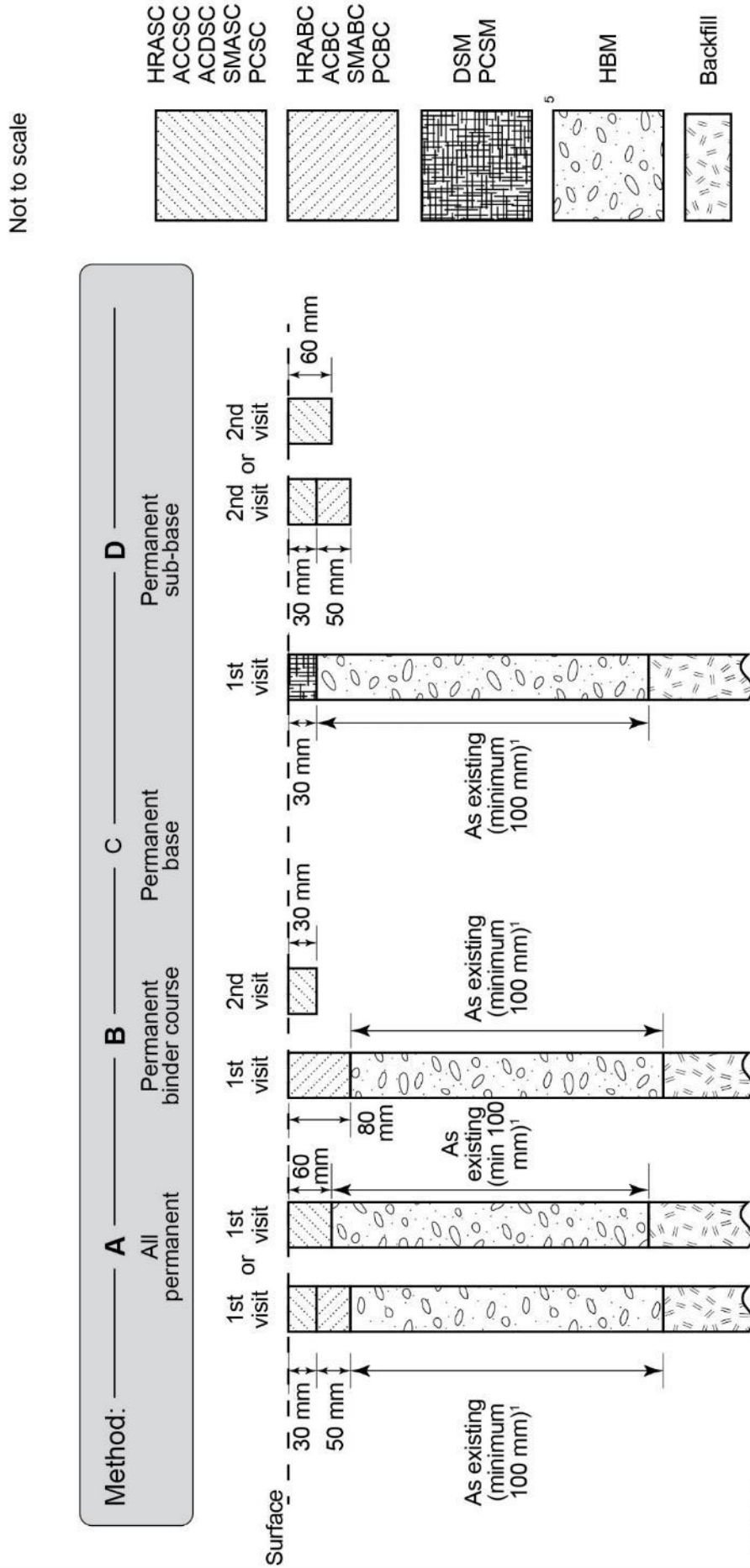
Not to scale



NOTES:

- 1) May be permanently reinstated on the first visit;
- 2) For alternative reinstatement materials refer to A9;
- 3) In small openings and narrow trenches CBGM base may be used as sub-base. Thickness must be 150 mm and the base must be bound.

Figure A7.2 Composite footways, footpaths and cycle tracks

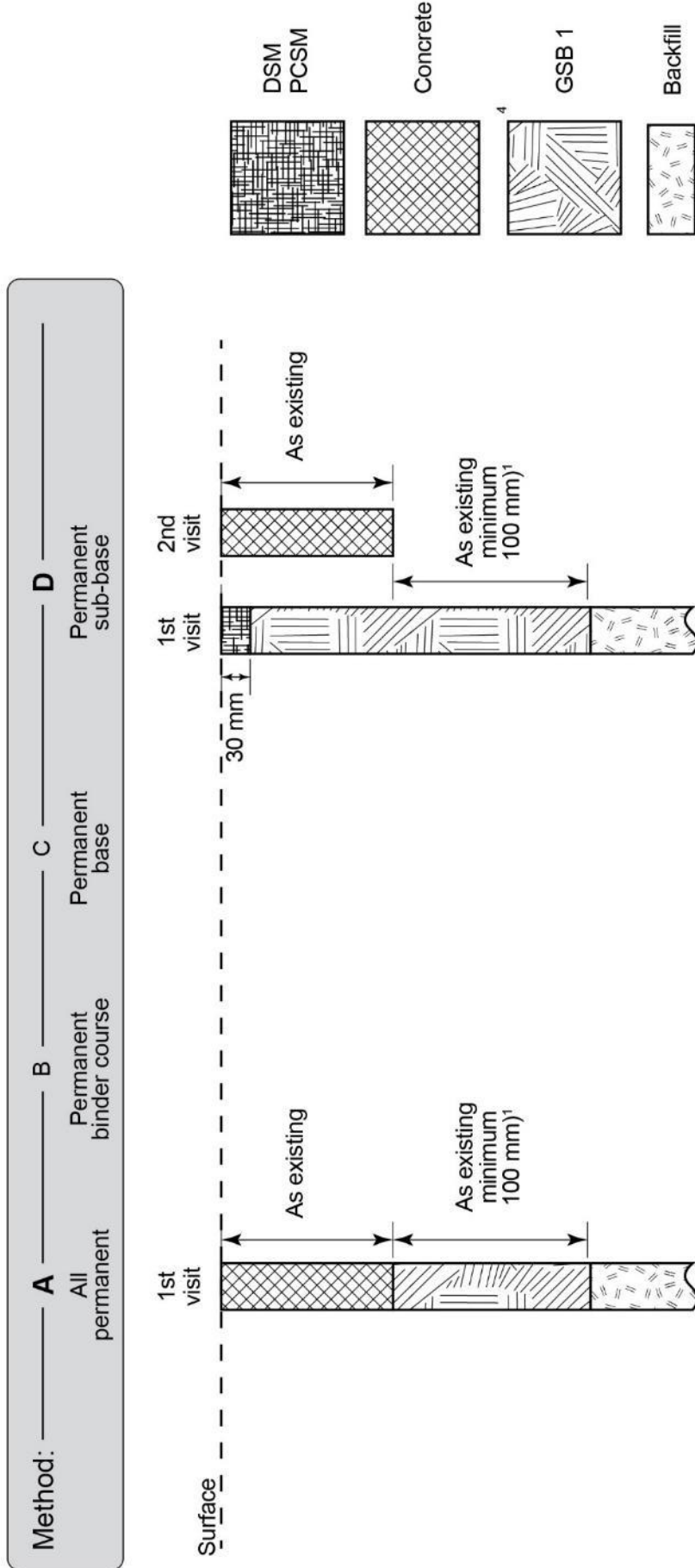


NOTES:

- 1) Class A graded granular is a permitted alternative;
- 2) For alternative reinstatement materials refer to A9;
- 3) PMMA may be used as sub-base, binder or surface course in small openings and narrow trenches (see S6.5);
- 4) In small openings and narrow trenches the sub-base can also be a HBM of 150 mm minimum thickness, a 50/20 HRABC or 20 mm DBC of 40 mm thickness or 3 layers of 15/10 HRA SC, 6 mm DCS or 6 mm SMA laid to a total thickness of 100 mm as combined sub-base, binder course and surface course;
- 5) See Table A10.6. FCR may be used in accordance with Table A2.1.

Figure A7.3 Rigid footways, footpaths and cycle tracks

Not to scale

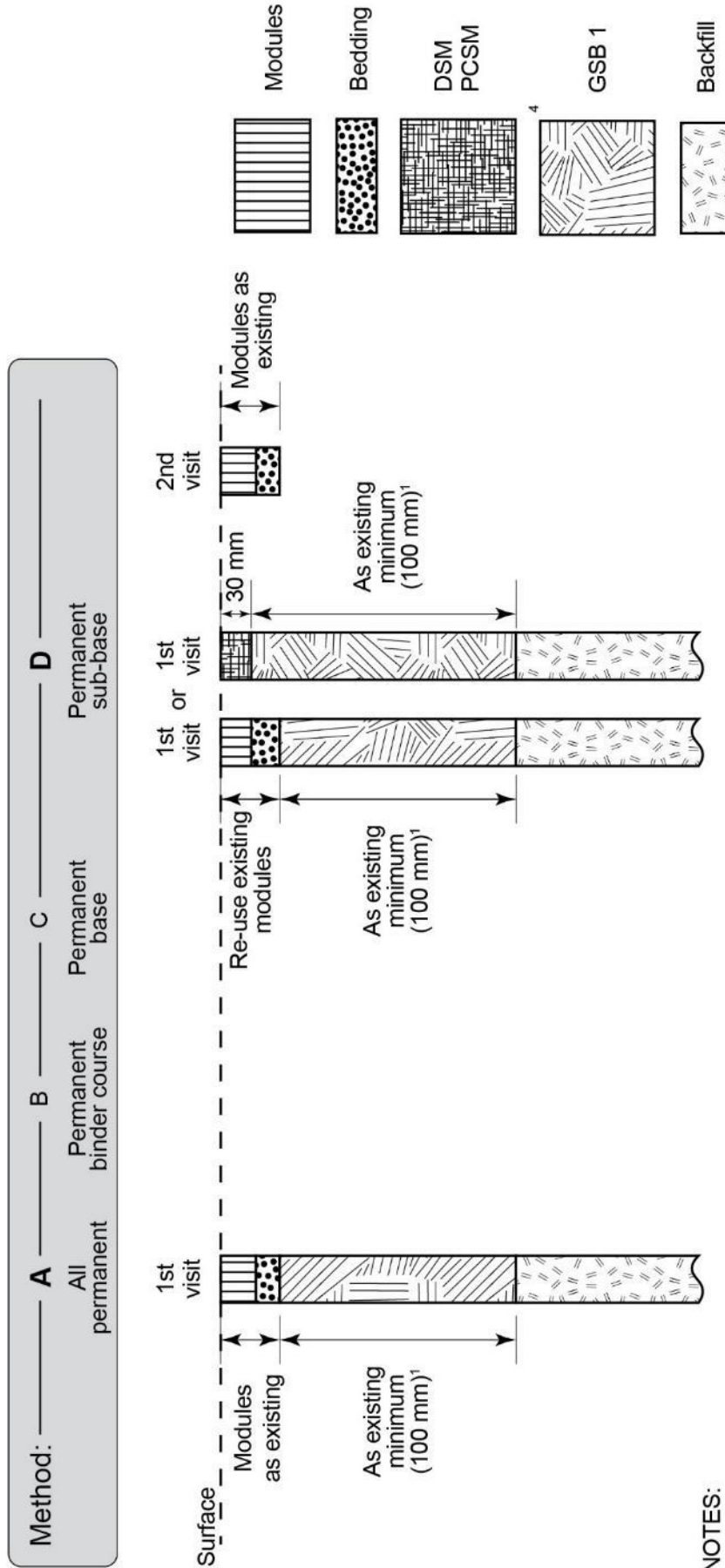


NOTES:

- 1) Class A graded granular is a permitted alternative;
- 2) For alternative reinstatement materials refer to A9;
- 3) In small openings and narrow trenches the sub-base can also be a HBM of 150 mm minimum thickness, a 50/20 HRABC or 20 mm DBC of 40 mm thickness or 3 layers of 15/10 HRA SC, 6 mm DCS or 6 mm SMA laid to a total thickness of 100 mm as combined sub-base, binder course and surface course;
- 4) HBM and FCR may be used in accordance with Table A10.6 and A2.1 respectively.

Figure A7.4 Modular footways, footpaths and cycle tracks

Not to scale



NOTES:

- 1) Class A graded granular is a permitted alternative;
- 2) For alternative reinstatement materials refer to A9;
- 3) In small openings and narrow trenches the sub-base can also be a HBM of 150 mm minimum thickness, a 50/20 HRABC or 20 mm DBC of 40 mm thickness or 3 layers of 15/10 HRA SC, 6 mm DCS or 6 mm SMA laid to a total thickness of 100 mm as combined sub-base, binder course and surface course;
- 4) HBM and FCR may be used in accordance with Table A10.6 and A2.1 respectively.

Appendix A8 Compaction requirements

A8.1 Granular, cohesive and cement bound materials

- A8.1.1 All granular, graded granular, cohesive/granular, cohesive and cement bound materials laid above the surround to apparatus must be compacted in accordance with Table A8.1.

Table A8.1 Compaction requirements for granular, cohesive and cement bound materials

Compaction plant and weight category	Cohesive material (less than 20% granular content)			Granular material (20% or more granular content including cement bound material)		
	Minimum passes/lift for compacted lift thickness up to			Minimum passes/lift for compacted lift thickness up to		
	100 mm	150 mm	200 mm	100 mm	150 mm	200 mm
Vibrotamper 50 kg minimum	4	8#	NP	4	8	NP
Single drum Vibrating roller 600-1000 kg/m	NP	NP	NP	12	NP	NP
1000-2000 kg/m	8	NP	NP	6	NP	NP
2000-3500 kg/m	3	6	NP	3	5	7
Over 3500 kg/m	3	4	6#	3	4	6
Twin drum Vibrating roller 600-1000 kg/m	NP	NP	NP	6	NP	NP
1000-2000 kg/m	4	8	NP	3	6	NP
Over 2000 kg/m	2	3	5#	2	3	4
Vibrating plate 1400-1800 kg/m ²	NP	NP	NP	5	NP	NP
Over 1800 kg/m ²	3	6	NP	3	5	7
All above plant	For maximum and minimum compacted lift thickness see Table A2.6					
Compaction of small openings and narrow trenches must comply with S6.5.						
Vibrotamper 25 kg minimum	Minimum 6 compaction passes Maximum 100 mm compacted lift thickness					
Percussive rammer 10 kg minimum						
Notes:						
1) NP = Not Permitted						
2) # = Not Permitted on wholly cohesive material i.e. clay or silt with no particles > 0.063 mm						
3) Single drum vibrating rollers are vibrating rollers providing vibration on only one drum						
4) Twin drum vibrating rollers are vibrating rollers providing vibration on two separate drums						
5) HBMs must be compacted in accordance with A10.2						
6) Mechanical pole tampers may be considered for compaction around iron work.						

A8.2 Chalk materials

A8.2.1 All chalk materials, including medium and high-density chawks must be compacted in accordance with Table A8.2. However, if the chalk is unstable after compaction, it must be removed and replaced with fresh material. Fresh chalk must be compacted in accordance with Table A8.2 except that the specified number of compaction passes must be reduced by one pass. If the chalk is still unstable after compaction, it must be replaced with suitable material.

Table A8.2 Compaction requirements for chalk materials			
Compaction plant and weight category	Chalk material		
	Minimum passes/lift for compacted lift thickness up to		
	100 mm	150 mm	200 mm
Vibrotamper 50 kg minimum	3	6	NP
Single drum Vibrating roller 600-1000 kg/m 1000-2000 kg/m 2000-3500 kg/m Over 3500 kg/m	12 6 NP NP	NP 8 4 NP	NP NP 6 4
Twin drum Vibrating roller 600-1000 kg/m 1000-2000 kg/m Over 2000 kg/m	6 2 NP	8 4 3	NP 6 4
Vibrating plate 1400-1800 kg/m ² Over 1800 kg/m ²	6 NP	8 6	NP 8
Alternative compaction plant for restricted areas			
Vibrotamper 25 kg minimum	Minimum of 6 compaction passes Maximum of 100 mm compacted lift thickness		
Percussive rammer 10 kg minimum			
Notes:			
1) NP = Not Permitted			
2) Single drum vibrating rollers are vibrating rollers providing vibration on only one drum			
3) Twin drum vibrating rollers are vibrating rollers providing vibration on two separate drums			
4) Mechanical pole tampers may be considered for compaction around iron work.			

A8.3 Bituminous mixtures

- A8.3.1 Bituminous mixtures for permanent reinstatements permitted in A2 must be compacted to the in-situ air void requirements of S10.2.8. Guidance on compaction procedures that may be capable of achieving the specified air voids values is given in NG A8.
- A8.3.2 Compaction should be discontinued if the mixture shows any signs of distress, regardless of whether the minimum number of passes suggested in NG A8 have been applied.
- A8.3.3 Compacted materials must be capable of being wet flush cored as follows:
- 1) Hot materials – upon reaching ambient temperature;
 - 2) PCSMs – at 6 months from the date of the permanent reinstatement.

Appendix A9 Alternative reinstatement materials and technologies

A9.1 Introduction

A9.1.1 New or alternative reinstatement materials (ARMs) and alternative technologies (ATs) may be developed for use in street works. ARMs and ATs might be used to improve safety or reduce disruption, cost, noise or other environmental impacts.

A9.1.2 There are three groups of ARMs:

- 1) Structural materials for reinstatements (SMRs, see A9.1.3)
- 2) Treated materials for fills (TMFs, see A9.1.4 and A9.1.5)
- 3) Other types of ARM, for example bituminous bound products (e.g. asphalt surfacing) that do not fit within the classification or application within A9.1. These can be used if they meet the performance requirements of this Code, are supported by a Quality System (A9.2.2) and are approved via A9 trials (see A9.5).

A9.1.3 SMRs include proprietary or alternative bound reinstatement materials that have a bituminous, cementitious, chemical or hydraulic binder or are inherently self-cementing. SMRs are categorised as follows:

a) Flowable SMRs (FSMRs)

- PMMA and FCR complying with A2.5 are not FSMRs and are not required to comply with A9.
- With the above exceptions, FSMRs comprise any type or combination of aggregates and binders that are flowable and do not normally require compaction.
- FSMRs may be used by agreement with the authority following the procedure detailed in A9.5.
- Layer thickness and compressive strength requirements must be in accordance with Table A9.1.

b) Non-flowable SMRs (NFSMRs)

- HBMs complying with A10.2 are not NFSMRs and are not required to comply with A9.
- With the above exceptions, NFSMRs comprise any type or combination of aggregates, soils and binders that are non-flowable mixes, and they normally require compaction on site. These materials may be used by agreement with the authority following the procedure detailed in A9.5.

- Layer thickness and compressive strength requirements must be in accordance with Table A9.1.

Table A9.1 SMR minimum layer thickness and strength requirements						
Layer	Road type					Footway, footpath or cycle track
	0	1	2	3	4	
Combined binder course & sub-base	NP	NP	NP	NP	NP	150 mm C1.5/2
Base	NP	NP	NP	300 mm C1.5/2	200 mm C1.5/2	---
Base & sub-base	NP	450 mm C3/4	450 mm C3/4	450 mm C1.5/2	350 mm C1.5/2	---
Sub-base &/or below	150 mm C1.5/2	150 mm C1.5/2	150 mm C1.5/2	150 mm C1.5/2	150 mm C1.5/2	100 mm C1.5/2
Strength class at 28 days	C3/4 minimum to C9/12 maximum C1.5/2 minimum to C9/12 maximum					
NP = Not Permitted (see A9.3.1)						

- A9.1.4 TMFs comprise any type or combination of aggregates, soils and binders that are non-flowable mixes and they normally require compaction on site. These materials may be used by agreement with the authority following the procedure detailed in A9.5.
- A9.1.5 CBR requirements must be in accordance with Table A9.2.

Table A9.2 TMF CBR requirements	
SMF class	% CBR
A	>15
B	7 to 15
C	4 to 7
D	2 to 4

- A9.1.6 New technologies, methods or techniques are termed alternative techniques (ATs) and may be used by agreement with the authority following the procedure detailed in A9.5. These include alternative excavation, compaction and any other alternative technology relevant to this Code.

A9.2 General requirements for ARMs and ATs

- A9.2.1 ARMs and ATs may only be used with the agreement of the authority obtained in accordance with the approval process described in A9.5.
- A9.2.2 The producer must maintain a Quality System that includes policy and procedures for production control. ARMs must be produced, handled, transported and used in accordance with the approved mix formulations

and procedures proven by prior development and testing. ATs must be used in accordance with the procedures established by prior development and testing.

- A9.2.3 The authority must be notified of any alterations to the proven mix formulations, mix proportions, aggregate type, admixtures, procedures, etc. Confirmation of their suitability must be agreed, and further development and testing may be needed.
- A9.2.4 ARMs used within 450 mm of the road surface must be non-frost susceptible, but see S5.3.2 and S5.3.3.
- A9.2.5 Where the authority is aware of areas with drainage or groundwater problems, it should notify the undertaker. Following such notification, the undertaker must provide ARMs that are permeable to a degree not less than the surrounding ground at backfill and sub-base levels within trench reinstatement. A backfill layer of pea gravel of 100 mm minimum thickness and surrounded by a geotextile filter fabric (where appropriate) may be considered to offer equivalent drainage potential.
- A9.2.6 Surfacing materials must not be reinstated until the ARM has attained sufficient strength or has an immediate bearing index sufficient to allow adequate compaction of overlaying materials and sustain adequate traffic loading.
- A9.2.7 FSMRs can flow into any damaged drains or ducts nearby. Where required, plastic sheeting may be needed to provide protection during pouring.

A9.3 Structural materials for reinstatements (SMRs)

Permitted uses of SMRs

- A9.3.1 SMRs may only be used as follows, and in any combination, regardless of the nature of the reinstatement materials in the layers above or below:
 - 1) At any position within the surround to apparatus or backfill, as the entire layer or combined with any other permitted backfill materials, in any proportion, within any reinstatement;
 - 2) As a sub-base within any reinstatement;
 - 3) As a combined sub-base and base within any reinstatement in road Types 1, 2, 3 & 4 and as base within any reinstatement in road Types 3 & 4;
 - 4) As a combined sub-base and binder course, within any reinstatement in footways, footpaths and cycle tracks.

General requirements for SMRs

- A9.3.2 SMRs must comply with the minimum layer thickness and compressive strength (Rc Class) requirements shown in Table A9.1.
- A9.3.3 Where the total thickness of SMR exceeds 1000 mm, the minimum strength class requirement of C3/4 must apply to the top 1000 mm with a minimum of C1.5/2 below this depth.

A9.3.4 The test must be carried out by a UKAS (or equivalent) accredited laboratory unless agreed otherwise.

Requirements for FSMRs

A9.3.5 Compressive strength must be determined in accordance with the principles of BS EN 12390-3, with the following exceptions or options:

- 1) Test specimens may be prepared at the time of placement by casting within a test mould or recovered from site after placement by extracting cores from the reinstatement.
- 2) Specimen shape and dimensions must be in accordance with BS EN 12390-1 with the addition that specimens may also be manufactured with an aspect ratio of 1. FSMR moulds may be manufactured from cellular foam (preferably polystyrene) and include a cellular foam lid. The samples must not be compacted except for minimal tamping to allow the mould to be filled without leaving excessive areas of voids.
- 3) The top and bottom surfaces of the extracted core may be grouted to provide flat and parallel loading surfaces.
- 4) Following preparation or recovery, the test samples must be stored upright at either 20°C or 40°C depending on the nature of the material, and tested in compression at 28 days after placement of the material on site.

A9.3.6 FSMRs must achieve the required performance without being tamped or compacted.

A9.3.7 In excavations containing water, the minimum recommended density for FSMRs is 1050 kg/m³.

A9.3.8 FSMRs are unlikely to provide adequate load bearing capacity for several hours after placement, depending on several variables including temperature and set time of the mix.

Requirements for NFSMRs

A9.3.9 NFSMRs

- 1) The compressive strength of NFSMRs must be determined in accordance with the principles of BS 1924-2 Section 7.3. Curing must be in accordance with BS 1924-2 section 7.2.4. Specifically, cores must be sealed or immersed in water at 20°C or 40°C (depending on the type of binder used) for 28 days.

Alternative sample manufacture techniques (including the use of cylinders or recovered cores of hardened specimens) may be adopted if they demonstrate equivalence to the above procedure.

- 2) NFSMRs may require compaction to ensure adequate strength. The compaction regime (i.e. details of plant type, weight category, lift/layer thickness and number of passes) must be specified before an NFSMR is used, and it should be determined by development and testing.

SMR material production

A9.3.10 FSMRs and NFSMRs must be prepared in accordance with an agreed process or with the procedures set out in the approval trial agreement (see

A9.5), and to the approved mix formulation(s) (derived from documented testing and compaction trials).

A9.3.11 FSMRs and NFSMRs may be delivered to site as ready-made materials or prepared partly or wholly on site.

A9.3.12 Mixing may be carried out using any equipment suitable for the manufacture of FSMRs and NFSMRs in the required quantities, provided the approved mixing procedure is used throughout. Mixing equipment must be maintained in accordance with the manufacturer's recommendations and checked regularly. All metering or weighing apparatus must be calibrated regularly according to a Quality Assurance Scheme.

A9.3.13 All binders, additives and admixtures, including diluted solutions thereof, must be stored according to the manufacturer's recommendations and used within the recommended shelf life.

A9.3.14 NFSMRs must be compacted in accordance with the manufacturer's recommendations or to an agreed compaction regime derived from development and testing.

A9.4 Treated materials for fills (TMFs)

Permitted use of TMFs

A9.4.1 TMFs may be used in place of other materials on a trial basis by agreement with the authority. They can be used in the layers appropriate to their CBR classification as defined by Table A9.2, and regardless of the nature of reinstatement materials used above and below, in any combination of the following:

- 1) At any position within the surround to apparatus or backfill, as the entire layer or combined with any other permitted backfill materials, in any proportion, within any reinstatement.
- 2) As a combined surround to apparatus and backfill within any reinstatement.
- 3) If classified as a TMF Class A material as per Table A9.2, it may also be used in the sub-base layer within any road, footway, footpath or cycle track.

A9.4.2 TMFs can only be used as described above.

Overall requirements for TMFs

A9.4.3 Each stabilisation or modification method and formulation must be classified with an equivalent to one of the four defined classes of backfill material permitted in A1, as follows:

- 1) Class A TMF Material – equivalent to Class A Graded Granular Backfill Material,
- 2) Class B TMF Material – equivalent to Class B Granular Backfill Material,
- 3) Class C TMF Material – equivalent to Class C Cohesive/Granular Backfill Material,

4) Class D TMF Material – equivalent to Class D Cohesive Backfill Material.

A9.4.4 The TMF material classification must be based on the soaked % CBR or equivalent value proven during the development and laboratory testing, in accordance with Table A9.2.

A9.4.5 The CBR value must be determined by laboratory testing in accordance with the principles of BS 1377 (soil) or BS1924 (material with hydraulic binder), with the following requirements:

- 1) Conventional steel test moulds may be unsuitable for some TMF materials (owing to the requirement to remove coarse aggregate >20 mm in size) and in-situ testing may therefore need to be considered. The preparation of TMF test samples may include test cores extracted from site.
- 2) Following preparation, the test samples are stored at ambient temperature for up to 90 days after the placement of the material on site.
- 3) The laboratory CBR test is performed on samples in a soaked condition (soaked for 4 days before testing).
- 4) The tests are carried out by a UKAS accredited laboratory unless mutually agreed otherwise.
- 5) On site, a recognised appropriate direct or indirect equivalent test method may be used.

TMF production

A9.4.6 TMFs must be prepared in accordance with an agreed process or with the procedures set out in the approval trial agreement (see A9.5), and to the approved mix formulation(s) derived from development and testing.

A9.4.7 TMFs can be prepared on site or delivered to site as a ready-mixed fill material. However, subject to results of development testing, the TMF mix may be transported by agreement with the authority,.

A9.4.8 Mixing can be carried out using any equipment suitable for the manufacture of TMFs in the required quantities, provided that the approved mixing procedure is used throughout. Mixing equipment must be maintained in accordance with the manufacturer's recommendations and checked regularly. All metering or weighing apparatus must be calibrated regularly according to a Quality Assurance Scheme.

A9.4.9 All binders, additives and admixtures, including diluted solutions must be stored according to the manufacturer's recommendations and used within the recommended shelf life.

A9.4.10 TMFs must be compacted in accordance with the manufacturer's recommendations or an agreed compaction regime obtained by prior development and testing.

A9.5 Outline scheme for approval trials

Introduction

- A9.5.1 Trials of ARMs or ATs may be carried under an approval trial agreement between the undertaker and the authority.
- A9.5.2 This section outlines a scheme under which trials of ARMs and ATs must be carried out. A9.5.5 gives general guidance relating to the organisation of an approval trial. A9.5.6 describes special conditions relating to the scale of an approval trial and its effect on organisational and reporting matters. A9.5.7 outlines the intended duties of each party within the approval trial. A9.5.9 to A9.5.11 provides a list of headings that describe the key requirements and stages of an approval trial. The headings are considered to represent the minimum essential information required to ensure that the approval trials are carried out in a controlled and agreed manner. The additional information under each heading is for guidance only. The parties to an approval trial (normally an undertaker (who would generally initiate or request the trial) and an authority) may, by agreement with the other party, add, amend or omit any details that do not affect the legal standing of the agreement.
- A9.5.3 When an ARM or AT has been approved by an authority following a successful trial, the undertaker can provide another authority with the trial data and ask permission to use the ARM or AT in its area. An ARM or AT trialled and approved by one authority must be accepted in different authority areas unless there is a reasonable engineering concern that requires local validation (for example, difference in type of road, pavement construction, position of the trench, etc.). Authorities can, within reason, request additional information if they have valid engineering concerns. If the undertaker is unable to satisfy the request for additional information, additional trials may be necessary.
- A9.5.4 ARMs and ATs can be used without trials if an authority agrees. However, where no trials have taken place, there is no requirement for another authority to accept the use of those ARMs or ATs.

General requirements, special considerations and duties of parties to approval trials

- A9.5.5 *General requirements for approval trials*
- 1) Trials may be undertaken in any road category with the approval of the authority. Trials cannot be undertaken in a high amenity or high duty footway, footpath or cycle track, or a site of special scientific interest unless by agreement. Off-site trials can also be used if appropriate.
 - 2) Approval trials in carriageways must be conducted on a minimum of three separate sites selected to represent a range of traffic conditions. A number of positions in the carriageway (e.g. within and outside a wheel track, longitudinal and transverse orientation (for trench reinstatements)) should also be considered.
 - 3) The duration of all approval trials must be agreed between the undertaker and the authority. The duration will depend on evidence of

performance, timescale to demonstrate performance and type of ARM or AT as follows:

- a) ATs used where the technology can be directly validated during the works (for example an alternative excavation or compaction method) should typically be less than a year. By the end of the trial, a technical report with evidence of compliance must be submitted.
 - b) For other ATs, if evidence of performance is presented (for example track record of use from other sectors or accelerated loading trials) the duration may be 2 years; however, in the absence of this it may be up to 5 years. By the end of the trial, a technical report with evidence of compliance must be submitted.
 - c) SMRs and TMFs complying with the requirements in A9 should be 2 years. By the end of the trial, a technical report with evidence of compliance must be submitted.
 - d) For other ARMs, if evidence of performance is presented (for example track record of use from other sectors, accelerated loading trials and durability testing) the duration may be 2 years. However, in the absence of this it may be up to 5 years. By the end of the trial, a technical report with evidence of compliance must be submitted.
- 4) A record of all test sites must be kept to enable effective monitoring and management of the asset. Specific details must be agreed as part of the Memorandum of Understanding for the approval process.
 - 5) The final inspection must be completed within one month following the end of trial period. The undertaker must notify the authority of the inspection date at least seven working days in advance. The authority must confirm their intention to attend or otherwise within seven working days of receipt of such notification. The inspection measures should be carried out on the notified date at an agreed time or an agreed alternative date. Where the authority does not attend the final inspection, the undertaker must provide the authority with a summary of the investigation within 28 days of the inspection. The undertaker should keep a photographic record of the approval trial reinstatements at the time of inspection and send copies to the authority.
 - 6) Core sampling and interim inspections of any type may be carried out on approval trial reinstatements at any time. Where required as part of the approval trial agreement, the undertaker must notify the authority at least five working days in advance of such works. Any holes created during these activities must be reinstated in accordance with the relevant requirements of this Code.
 - 7) Reinstatements may be accidentally damaged during the trial and rendered unsuitable for accurate assessment. It is therefore recommended that trials should include duplicate sites for each road type, category, position, orientation, etc.
 - 8) Where an approval trial reinstatement requires remedial action, then regardless of the reason, the undertaker must provide the authority with details of the remedial measures within one month of completion. Where practicable, records of surface measurements, photographs etc

taken before and after the remedial work should be kept by the undertaker and copies provided to the authority.

- 9) With the approval of the authority, further use of the ARMs or ATs under trial may be permitted before completion of the trial. Such approval will only apply to works carried out within the boundary of the authority that has given approval. Further use of ARMs or ATs can only be in road categories up to and including the highest category used for the approved trial.
- 10) On successful completion of the approval trial, the results, audit trail and Factory Production Control or Quality System documentation should be shared with other authorities from whom permission for further use is to be sought. By agreement between the parties involved, some or all of the details of the trials can be forwarded to Regional HAUC or National HAUC to allow them to be made available nationally. Further use of ARMs or ATs can only take place in road categories up to and including the highest category used for the approved trial.
- 11) After successful completion of an approval trial, permission for further use of the ARM or ATs must not be unreasonably withheld by any other authority and must only be denied for engineering reasons. Where reasonable engineering concerns are expressed, the nature of which must be stated, then additional assessment may be required by the authority.
- 12) It is recognised that the scope, extent and duration of ARM and AT approval trials may vary widely.

A9.5.6 *Special considerations for approval trials*

- 1) For small-scale approval trials intended to take place on a small number of sites and over a fixed period of time (e.g. for specially prepared approval trial excavations), the undertaker must notify the authority at least one month in advance of each trial.
- 2) Specially prepared excavations should be of similar depth and plan dimensions to the undertaker's routine excavations, and generally not less than 500 mm by 500 mm in plan, or not less than 200 mm wide for trench excavations. The total combined surface area of all approval trial sites should not be less than 2 m².
- 3) The location and position of the approval trial reinstatements should represent as wide a range as possible (see A9.5.5(2)). If specially prepared sites are to be used, the site locations may be jointly selected.
- 4) Large-scale trials, such as those where the material or technique is used during works, may take place over a longer time period. The undertaker must notify the authority of such trials at least one month before they start. Arrangements for notification and attendance at the trials should be included in the trial agreement.
- 5) Any restrictions on size, location and position, number of approval trial sites or the period during which the approval trial reinstatements may be carried out, should also be included in the approval trial agreement.

- 6) The agreed trial period starts on the date of installation. Dates for submission of an interim report on the trial should be agreed, with the report being submitted in the agreed period. The final review or reporting must be carried out when the trial sites have reached the agreed age.

A9.5.7 *Duties of parties to approval trials*

- 1) The initiator (usually the undertaker) would be expected to have carried out documented development work to ensure a high level of confidence in the proposed ARM or AT before starting the approval process. The results of such development work should not be unreasonably withheld from the authority.
- 2) The undertaker must provide as much notice of the approval trial reinstatement operation(s) (e.g. location, date/time, excavation, mixing, reinstatement, sampling, post-construction activities etc.) as practically possible, in accordance with the requirements of the approval trial agreement.
- 3) The undertaker must not unreasonably withhold information relating to any aspect of the approval trial from the authority.
- 4) The authority must not unreasonably obstruct approval trials or cause their termination provided they are carried out in accordance with the terms of the approval trial agreement.
- 5) Either party has the right to request confidentiality on any matter relating to the approval trial.

Suggested information for inclusion in approval trial agreement

A9.5.8 Before starting an approval trial, the following information should be considered by both parties for inclusion in the approval trial agreement.

A9.5.9 *General information*

- 1) Parties to trial** – names of undertaker and authority agreeing to approval trial
- 2) Confidentiality** – parties (if any) to whom trial information may be divulged
- 3) Geographical extent of trial** – county or district border, utility region or area boundary
- 4) Scope of trial** – total number of trial reinstatements or maximum number of sites
- 5) Time limit for trial** – start/end dates
- 6) Termination criteria** – conditions under which agreement may be ended and notice of termination
- 7) Signatories/witnesses** – approved officers of appropriate seniority who are permitted to commit their organisation to the execution of the approval trial and who can approve the terms and conditions of the trial
- 8) Record of sites where the ARM or AT has been used and dates of installation**

A9.5.10 *Procedural*

- 1) **Contemporary records** – details of records required, responsibility for record-keeping
- 2) **Notification details** – notice periods, arrangements for contacting relevant parties to an approval trial
- 3) **Attendance at trials** – parties who may attend an approval trial
- 4) **Review periods/meetings** – dates, participants, procedures for calling ad hoc meetings
- 5) **Post-construction assessment** – test methods to be employed and arrangements for periodic surveying, sampling, etc

A9.5.11 *Technical*

- 1) **Type of trial site** – routine utility excavations or specially excavated approval trial
- 2) **Location of trial site** – non-high-amenity or non-high-duty footway, cycle track, (including road classification Type 2 to 4) etc
- 3) **Positioning of trial site** – “as excavated”, within wheel track, etc
- 4) **ARMs or ATs to be trialled** – generic SMR or SMF materials
- 5) **ARM or AT details** – Mix design, binder details, additives, dependencies on site conditions or excavated/base material type and condition, details of prior development work
- 6) **ARM or AT preparation** – batching, mixing and placement procedures.
- 7) **Quality control on site** – any tests to be applied to ensure that an ARM has been prepared to the required design
- 8) **Compaction regime** – NFSMRs and SMRs only
- 9) **Sampling requirements** – types of samples and sampling frequency
- 10) **Testing laboratories** – contact details of accredited laboratories or otherwise
- 11) **Remedial measures for “failed” sites** – replacement with an alternative SMR or SMF material or other approved material or remove from the approval trial agreement
- 12) **Future of trial sites** – remove after trial completion or leave in place, future monitoring or testing
- 13) **Any specific assessment management or maintenance requirements.**
- 14) **Confirmation of compliance** with all SROH performance requirements; linked to inspection and defects

Appendix A10 Additional standard materials

A10.0 General

A10.0.1 This appendix includes specifications for hydraulically bound and unbound materials that are options for use in reinstatements drawn from BS EN standards. These materials may be used where listed as an option in this standard. Many of them have technical advantages compared with conventional alternatives, including a modified Type 1F Unbound Mixture (0/20) to mitigate technical risks associated with potential segregation and non-uniform compaction within reinstatements.

A10.0.2 The quality control requirements under A10 for HBMs are for production sites that include specific constituent storage, testing and other related quality control procedures, as specified in BS EN 14227. Products that do not comply with all the requirements of A10 may be proposed under A9.

A10.1 Modified Type 1F Unbound Mixture (0/20)

A10.1.1 Modified Type 1F Unbound Mixtures must be made from natural aggregate (excluding uncrushed flint based or quartz based gravels), recycled aggregates, manufactured aggregates or well burnt non-plastic shale, or a combination of these, and may contain up to 10% by mass of natural sand passing a 4 mm test sieve.

A10.1.2 The mixture must comply with BS EN 13285 and the grading requirements of Table A10.1.

Table A10.1 Grading for Modified Type 1F Unbound Mixture (0/20)

Sieve size, mm	Percentage by mass passing		
	Overall grading range	Supplier declared value grading range	Tolerance on the supplier declared value
40	100	---	---
20	75 - 99	---	---
10	43 - 81	54 – 72	± 15
4	23 - 66	33 – 52	± 15
2	12 - 53	21 – 38	± 15
1	6 - 42	14 – 27	± 13
0.5	3 - 32	9 – 20	± 10
0.063	0 - 12	---	---
Grading of individual batches – differences passing selected sieves			
Retained sieve size, mm	Passing sieve size, mm	Percentage by mass passing	
		Not less than	Not more than
4	10	7	30
2	4	7	30

A10.1.3 Aggregates used in the mixture must be in accordance with BS EN 13242 and Table A10.2.

Table A10.2 Requirements for aggregates used in Modified Type 1F Unbound Mixture

Crushed, or broken and totally rounded particles crushed rock, crushed manufactured and crushed recycled aggregates (see NOTE)	C _{90/3}
Resistance to fragmentation – Los Angeles test	LA ₅₀
Resistance to wear – micro-Deval test	MDE NR (no requirement). The supplier must state the value for the aggregate used
Resistance to freezing and thawing – magnesium sulphate soundness	MS ₃₅
Water absorption	WA24NR (no requirement). The supplier must state the value for the aggregate used.
Volume stability of blast furnace slags	Free from dicalcium silicate and iron disintegration
Volume stability of steel (BOF and EAF) slags	V ₅
All other BS EN 13242 aggregate requirements	Category NR (no requirement).
Note: BS EN 13242 assumes that crushed rock aggregates comply with category C90/3 without further testing.	

A10.1.4 The size fraction of the unbound mixture passing a 0.425 mm size test sieve must be non-plastic, as defined by BS EN 17892-12:2018, and tested in compliance therewith.

A10.1.5 Where the mixture contains recycled coarse aggregate or recycled concrete aggregate, it must be classified by hand sorting the coarse aggregate particles in accordance with BS EN 933-11. The test must be carried out by a suitably trained laboratory technician competent in classifying the constituent classes in accordance with the test method. Recycled coarse aggregate and recycled concrete aggregate must also comply with the requirements of Table A10.3.

Table A10.3. Recycled coarse aggregate and recycled concrete aggregate used in Modified Type 1F Unbound Mixtures

Component	Maximum permitted content (% by mass)
Asphalt (Class Ra)	50
Glass (Class Rg)	25
Other materials (Class X), including wood, plastic and metal	1

A10.1.6 The Modified Type 1F Unbound Mixtures must be non-frost susceptible. Material is classed as non-frost-susceptible if the mean heave is 15 mm or less when tested in accordance with BS 812-124. Comparator specimens with Annex B of BS 812-124 must be used.

A10.2 Hydraulically bound materials (HBMs)

A10.2.1 HBMs must be in accordance with one of the following standards, depending on the binder used:

- 1) BS EN 14227-1: Cement bound granular mixtures
- 2) BS EN 14227-2: Slag bound granular mixtures
- 3) BS EN 14227-3: Fly ash bound granular mixtures
- 4) BS EN 14227-5: Hydraulic road binder bound granular mixtures
- 5) BS EN 14227-15: Hydraulically stabilized soils

A10.2.2 Any HBMs not covered within A10.2 will require approval trials in accordance with A9.

A10.2.3 The HBM producer must make available to the undertaker and authority the information detailed in the 'Designation and Description' clause of the relevant part of BS EN 14227 for the selected HBM. In addition:

- 1) Target proportions of constituents must comply with the requirements of the relevant BS EN as per A10.2.1;
- 2) Mixture design details and results must be carried out in accordance with A10.2.11 to A10.2.16;
- 3) Mixture performance requirements must be in accordance with A10.2.17;

- 4) Method Statement for production, transport, placement and control must be in accordance with A10.2.37 to A10.2.40.

Constituents

A10.2.4 Aggregates and binders for HBM must comply with BS EN 14227, the respective BS EN specified in Table A10.4 and the requirements of this clause.

Table A10.4 Standards	
Constituent	BS EN
Aggregates	BS EN 13242
Water	BS EN 1008
Cement	BS EN 197-1
GBS (granulated blast furnace slag)	BS EN 14227-2
GGBS (ground granulated blast furnace slag)	BS EN 15167-1
Lime	BS EN 459-1
Gypsum	BS EN 14227-2 or BS EN 14227-3
FA (Fly ash)	BS EN 14227-4
ASS (Air-cooled steel slag)	BS EN 14227-2
HRB (Hydraulic road binder)	BS EN 13282

A10.2.5 The binder constituent proportions must comply with Table A10.5 and must be based on a laboratory mixture design procedure in accordance with A10.2.11 to A10.2.16.

Table A10.5 Minimum binder or binder constituent additions		
Binder or binder constituent	Mode of use (mode of use not listed below must be subject to approval by the authority)	Minimum addition by dry mass of mixture
Lime / cement / HRB / GGBS	when used with another binder constituent	2%
	when used as sole treating agent	3%
ASS & GBS	when used together	2.5% each
Dry fly ash	when used with cement	4%
	when used with lime	5%
Conditioned (i.e. wet) fly ash	All applications	6%

Storage of constituents at the central mixing hub

- A10.2.6 Aggregates must be stored on a firm and clean substrate for at least 24 hours before mixture production. Contamination with other constituents must be avoided.
- A10.2.7 Lime, cement, GGBS, HRB and dry fly ash must be stored sealed in, for example, a silo or suitable bags.
- A10.2.8 Conditioned (wet) fly ash must have no agglomerations greater than 10 mm size, measured by sieving samples through a 10 mm sieve with no more than 10 seconds gentle agitation. It must be stored under cover for at least 72 hours at a minimum water content of 10%, before mixture production.
- A10.2.9 GBS and ASS must be stored as aggregates and used within 3 months of delivery.
- A10.2.10 All constituents must be protected from freezing to ensure suitability for use.

Laboratory mixture design procedure for HBM

- A10.2.11 The producer must design the mixture in accordance with the procedure described here to meet the compressive strength of A10.2.17.
- A10.2.12 The composition of HBM must be based on mixture design testing carried out using a minimum of 3 binder contents and a minimum of two water contents at each binder content.
- A10.2.13 The immediate stability at the design water and binder content must be determined using the IBI test in accordance with BS EN 13286-47. The IBI value must be taken as the average of a set of 3 test specimen results.
- A10.2.14 The effect of immersion in water on compressive strength must be assessed in accordance with BS 1924-2 as follows:
- 1) y^1 and $y^2 = 20^\circ\text{C}$ for mixtures containing cement or 40°C for mixtures not containing cement
 - 2) R_{Rc} must be ≥ 80
 - 3) On completion of the immersion stage (y^2) the test specimens must show no signs of cracking or swelling
- A10.2.15 Strength is taken as the average of at least 3 specimens. The mean of the test results must be greater than the specified strength (C1.5/2 or C3/4) and no individual result can fall below 67% of the strength requirement class. In addition, the mean of the test results must not exceed C9/12.
- A10.2.16 HBM must be non-frost susceptible. Material is classed as non-frost-susceptible if:
- 1) the compressive strength class is C3/4 minimum, or
 - 2) the mean heave is 15 mm or less, when tested in accordance with BS 812-124, with the sample preparation in accordance with BS 1924-2.

Mixture performance requirements

A10.2.17 Layer thickness and compressive strength at an age of 28 days requirements must be in accordance with Table A10.6.

Table A10.6 HBMs minimum layer thickness and compressive strength						
Layer	Road type					Footway/ footpath/ cycle track
	0	1	2	3	4	
Combined Binder course & Sub-base	NP	NP	NP	NP	NP	150 mm C1.5/2
Base	NP	NP	NP	300 mm C1.5/2	200 mm C1.5/2	---
Base & sub- base	NP	450 mm C3/4	450 mm C3/4	450 mm C1.5/2	350 mm C1.5/2	---
Sub-base or below	150 mm C1.5/2	150 mm C1.5/2	150 mm C1.5/2	150 mm C1.5/2	150 mm C1.5/2	150 mm C1.5/2
Maximum strength class at 28 days	C9/12					C8/10
Notes: NP = Not permitted Minimum asphalt overlay thickness as per A3 to A7 HBMs are not permitted as CBGM base replacement						

Requirements for production, storage and transport of HBMs

- A10.2.18 The HBM must be produced at a central hub facility using a plant that batches by mass and mixes in a forced-action mixer allowing sufficient time in the mixer to produce a homogenous mixture.
- A10.2.19 The producer's quality manual should describe the characteristics of any constituent or mixture storage system and define their mode of operation. The producer must ensure through checks, inspections and records, that such systems are used correctly, and that constituents and mixtures maintain their suitability for use during storage.
- A10.2.20 The minimum temperature at the time of production of HBM is 3°C and rising.
- A10.2.21 At production, the constituents, and on leaving the production facility, the HBM must be free from ice and frozen agglomerations.
- A10.2.22 On leaving the production facility, HBM must have a water content suitable for compaction as determined during the design stage and monitored in accordance with the production quality control plan.
- A10.2.23 HBM must be transported directly to the point of placement and protected from the weather during transit and unloading.

Production control testing and checks

A10.2.24 The HBM producer must have an established and maintained quality manual describing policy and procedures for production control in accordance with the production control annex of BS EN 14227 and as follows.

A10.2.25 *Tests & checks before and during production*

- 1) Constituents sourced off-site require monthly certification (or by delivery for cement etc); aggregates to BS EN 13242, cement to BS EN 197, fly ash to BS EN 14227-4 and GBS and GGBS to BS EN14227-2 Annex A.
- 2) In accordance with BS EN 14277, and using the mixing plant's automated surveillance and data collection system where appropriate, characteristics that require control during production include:
 - a) pre-production properties of the constituents including plasticity, water content, and freedom from frozen agglomerations
 - b) proportioning of the constituents including added water
 - c) grading of the fresh mixture
 - d) water content of the fresh mixture
 - e) time of production
 - f) temperature at production
- 3) The proportioning must comply with the requirements of the target composition of the mixture.
- 4) The above tests and checks must be carried out daily and recorded.

A10.2.26 *Laboratory mechanical performance tests*

- 1) Each day of production, or as detailed in the Quality Manual/Method Statement, the producer must sample the HBM for compliance with the compressive strength of Table A10.7 Sampling must be in accordance with BS 1924-1.
- 2) Cubic or cylindrical specimen manufacture, curing and testing for compressive strength must be in accordance with Table A10.7. Cubes for compression testing must be 150 mm nominal size.
- 3) A representative sub-sample must be taken from each sample for the determination of water content in accordance with BS 1924-2. Sampling must be in accordance with BS 1924-1.

Table A10.7 Compressive strength testing requirements for HBMs

Cement used	Specimen manufacture, nominal wet density & curing regime	Curing temperature	Test method for determination of R_c	Age at test
Yes	BS 1924-2 and BS EN 13286-41	20°C	BS EN 13286-41	28 days (See note)
No		40°C		
Note: For control purposes, HBM may be assessed on the basis of 7-day or other early age strength, provided that a correlation is established between the early age and 28-day strength				

Requirements for placement, compaction, protection and overlay

A10.2.27 Laying and compaction of HBM layers, including any reworking and re-use, whether constructed in one or more lifts, must be carried out without segregation, drying out or before setting.

A10.2.28 The construction period, in degree hours, is the summation of the products of the average air temperature above 3 °C (temperature T in °C) and time for each period (time t in hours): i.e. construction period limit = $\Sigma(T.t)$. The air temperature during the interval, t, must not fluctuate by more than 4 °C. The construction periods are summarized in Table A10.8 and Table A10.9.

Table A10.8 Construction period for HBM when one binder constituent only or binder constituents added at the same time

Binder	Construction period (°C·h)
Other constituents, combinations, possibilities not listed below in this table	Producer to determine and evidence during the mixture design procedure
CEMI used as part of the mix	35
Lime with GGBS	200
Lime with SiFA (SiFA both as a binder constituent and as aggregate)	850
Lime alone	1700
GBS alone, ASS alone, GBS + ASS	3000

Table A10.9 Construction period for HBM when one binder constituent only or binder constituents added at the same time

Binder	Construction period (°C·h)
Other constituents, combinations, possibilities not listed below in this table	Producer to determine and evidence during the mixture design procedure
SiFA followed by CEMI	35 after cement addition
GGBS followed by CEMI	35 after cement addition but within 850 of GGBS addition
Lime followed by CEMI	35 after cement addition but within 1700 of GGBS addition
Lime followed by GGBS	200 after GGBS addition but within 1700 of lime addition
Lime followed by SiFA	850 after SiFA addition but within 1700 of lime addition
GBS + ASS	3 000 after final addition

- A10.2.29** The minimum layer thickness or lift thickness for layers constructed in two or more lifts is 100 mm. Where the total thickness laid exceeds 1000 mm, the minimum strength class requirement of C3/4 applies to the top 1000 mm only, with a minimum of C1.5/2 below this depth.
- A10.2.30** Making-up the surface level of the layer after initial compaction is not permitted for single lift working or for the uppermost lift in multiple lift working.
- A10.2.31** For multiple lift working, fresh HBM must not be laid on HBM that has been allowed to dry. The temporary intermediate surfaces of lifts must be kept moist.
- A10.2.32** The face of previously compacted HBM or other material must be vertical and straight before butting fresh material against it.
- A10.2.33** Compaction to refusal of the HBM must be carried out in accordance with the method for granular and cement bound materials in Table A8.1.
- A10.2.34** After compaction, the surface must be closed and free from cracks, loose or segregated material, visible voids and other defects. All defective areas must be rectified within the construction period for the binder stated in Table A10.8. If rectification is not completed within the construction period, the defective area must be removed to the full thickness of the layer, and new mixture laid and compacted.
- A10.2.35** *Cold and wet weather working*
- 1) HBM must not be laid on a frozen surface.
 - 2) In the case of heavy or persistent rain, works must cease and laid material must be compacted immediately.

A10.2.36 *Curing, protection and overlay of HBM*

- 1) Unless overlain immediately, the upper surface of the HBM must be cured to prevent loss of moisture by applying a bituminous emulsion spray complying with BS 434-1 at a minimum rate of 0.5 l/m² to produce an even and continuous coverage of bitumen. The surface must be free of loose material and standing water before spraying. The curing membrane must be protected from any damage until placement of the overlaying layer.
- 2) Overlaying of the HBM is permitted at any time for HBM with IBI category IPI25. Alternatively, overlay is only permitted once the material has gained sufficient strength to enable compaction of the overlying layer.

Method Statement

A10.2.37 The producer must provide a method statement for the HBM detailing best practice for placement, compaction, curing and protection of the reinstatement, including procedures for cold joints, inclement weather, plant breakdown and record keeping.

A10.2.38 The statement must include the intended mixture constituents and proportions, with supporting data from the mixture design results from A10.2.11 to A10.2.16 and/or historic records to justify the constituents and proportions including water content.

A10.2.39 The statement must include a sample record sheet for submitting the data required in A10.2.17.

A10.2.40 The undertaker must not change construction procedures without the agreement of the producer.

Appendix A11 Product Equivalence

The UK has now left the European Union, but European regulatory standards remain part of retained UK law, until determined otherwise. For the purposes of this document therefore, the use of any material or product from the EU that has been deemed to be equivalent to any material or product specified in this Code is considered to be in accordance with this Code until further notice.

Appendix A12 Reinstatement of modular surface layers

A12.1 Interim reinstatement

- A12.1.1 Where an interim reinstatement is required, the existing modules should be re-used, including any broken modules. Where damage has resulted in fragmentation or widespread breakage of modules [subject to the special case of natural material modules (as set out in A12.2.5 and A12.2.6)], then bituminous mixtures may be used for an interim reinstatement provided they meet the performance requirements of S2 and compaction of such mixtures does not result in further damage to adjacent modules.

A12.2 Permanent reinstatement

General

- A12.2.1 Permanent reinstatement of modular surface layers should be generally carried out in accordance with BS 7533.
- A12.2.2 Permanent reinstatement of modules must include all modules situated within or beyond the effective width of the reinstatement (W) described in S2.1.5 and must also include any other modules disturbed in the course of carrying out excavation or reinstatement.
- A12.2.3 Clean undamaged modules must be re-used for permanent reinstatement. Broken modules cannot be used for permanent reinstatement and must be replaced.
- A12.2.4 Laying course material must be sand or mortar, to match the characteristics of the existing type and thickness. Unless otherwise notified by the authority, where sand is present, laying course and jointing materials must be in accordance with BS 7533-3. For all roads and footways, the grading of the laying course material must be in accordance with Table D.3 Category II. Jointing materials to Section D1.2, must be applied to gaps between individual modules at the time of permanent reinstatement. Where mortar has been used for laying course material the undertaker must seek guidance from the authority as to the specification to be used. This information must not be unreasonably withheld.

Requirements for natural material modules

A12.2.5 *General for whole natural material modules*

The reinstatement of whole natural material modules must be in accordance with the general requirements of A12.2.1 to A12.2.4.

A12.2.6 *Damaged natural material modules*

- 1) Where damaged modules are to be re-used in the reinstatement, a joint inspection must be arranged before starting excavation to agree the extent of usage of damaged modules and the minimum size acceptable for re-use.
- 2) The undertaker should make a photographic record of the joint inspection which should be agreed between the undertaker and the authority.
- 3) The undertaker must use best endeavours to match existing profiles and meet the tolerances specified in S2. However, where the pre-existing profile of damaged modules is near or in excess of current intervention and construction tolerances specified in S2, it will be difficult for the undertaker to construct a complying reinstatement. The undertaker must use best endeavours to ensure that the interface between the reinstatement and the adjoining surfaces does not create a hazardous trips.

Infills in modular reinstatements

A12.2.7 *General*

- 1) Where gaps greater than 5 mm between the nearest module and the immediately adjacent fixed feature (such as edgings, channel blocks, drainage features, surface boxes, ironware) or boundary feature (such as walls, fences and the like) arise as a direct result of works, the undertaker should avoid the gap by cutting the modules to the proper dimensions. If this is not possible, the undertaker must fill the gaps to the full depth of the adjacent paving module as follows:
 - a) for smaller gaps a 1:4 cement to sand mortar ratio should be used;
 - b) for larger gaps, where aggregate can be used, a 1:5:3 cement to sand to aggregate concrete ratio should be applied, using a maximum aggregate size of 10 mm.
 - c) alternatively, PMMA can be used as infill prior agreement with the authority.
- 2) Infills should generally be as small as possible. Where the physical characteristics of the bond, fixed feature, or proximity of other fixed features do not allow for a small infill, then best endeavours should be used to achieve surface tolerances (see S2) with the smallest infill possible.
- 3) Infills should match existing work by the Authority.
- 4) If the gap requiring a new cement infill is the result of an uneven surface (existing before commencement of the works), the new cement infills

should be limited to a 1 year guarantee. All practicable effort should be made to avoid the use of cement infills for this application. For the 1 year guarantee to apply to the cement infills the undertaker is required to document the existing surface before commencement of works and must be able to demonstrate why all alternatives to the use of cement infills for this application have been ruled out.

A12.2.8 *Infill widths and limitations*

- 1) Where possible, infills should be limited to a maximum width of 50 mm in modular areas, irrespective of whether the existing footway was originally constructed in accordance with BS 7533.
- 2) In the case of modules where one side of the module is greater than 305 mm, there are instances where it is permissible to increase the width of the infill to a maximum of 150 mm to achieve a better engineered and more aesthetically pleasing reinstatement. These include instances where the intervening distance is less than 150 mm:
 - a) between the undertaker's newly laid apparatus and the nearest module (on any side), or
 - b) between two or more pieces of undertaker's newly laid apparatus, or
 - c) to an existing fixed or boundary feature.

Where it can be shown to be acceptable custom and practice, in exceptional cases the maximum permissible infill width may be increased to 200 mm for irregularly shaped apparatus. Typical examples are in NGA12.

- 3) Similarly, for modules where all sides are 305 mm or less, there are instances where it is permissible to increase the width of the infill to the same as the full width of module (measured on the shortest side) to achieve a better engineered and more aesthetically pleasing reinstatement. These include instances where the intervening distance is less than the full width of a module plus 25 mm (measured on the shortest side):
 - a) between the undertaker's newly laid apparatus and the nearest module (on any side), or
 - b) between two or more pieces of undertaker's newly laid apparatus, or
 - c) to an existing fixed or boundary feature.

Typical examples are in NGA12.

A12.2.9 *Acceptable localised loss of modular pattern*

- 1) Physical characteristics may prevent or limit the possibility of completing a uniform and closely matching modular reinstatement immediately adjacent to features. The physical characteristics of the module itself, the existing as-laid bond, as well as the physical characteristics of the fixed or boundary feature, may individually or collectively contribute to such a situation.
- 2) In all instances, the undertaker should attempt to minimise the width of the infill. However, the following exceptions are permissible:

- a) Where the above physical characteristics are present, permanently reinstated modules immediately adjacent to the feature may be laid with a degree of localised loss of bond pattern. The introduction of a stringer (or in some cases, soldier) course immediately adjacent to the feature is not considered as a loss of bond pattern. The loss of bond pattern should be limited, where practicable, to the first two rows beyond any stringer course, being laid in such a manner as to aesthetically integrate with the surrounded bond pattern. Typical examples are indicated in NGA12.
- b) If adjacent modules abut an existing contiguous infill such as at a property boundary, then the infill must match the existing.
- c) In the case of fixed features that are not rectangular, there is no requirement to cut modules to match the edge profile of the fixed feature to otherwise reduce the infill at irregular edges.
- d) Where localised custom and practice adopted by the authority for its own works differs from the above, infills may be laid to a standard consistent with that of the authority.

A12.3 Provision of replacement modules

- A12.3.1 Authorities are advised to retain stocks of modules used in their areas to enable them to provide replacements when required. Where no suitable replacements are available, authorities should assist undertakers in locating sources elsewhere.
- A12.3.2 Every effort should be made to match, in order of preference, the colour, shape and size of existing modules when reinstating the site.
- A12.3.3 Where modules are found to be damaged before work starts, the authority may provide suitable replacements to the undertaker, free of charge.
- A12.3.4 Where replacements modules are required owing to loss or breakages arising from the undertaker's works, the undertaker must reinstate with modules purchased at the undertaker's expense or purchased from the authority at reasonable cost.
- A12.3.5 If an appropriate module is not identified, the undertaker must use best endeavours to use the most appropriate source of modules.

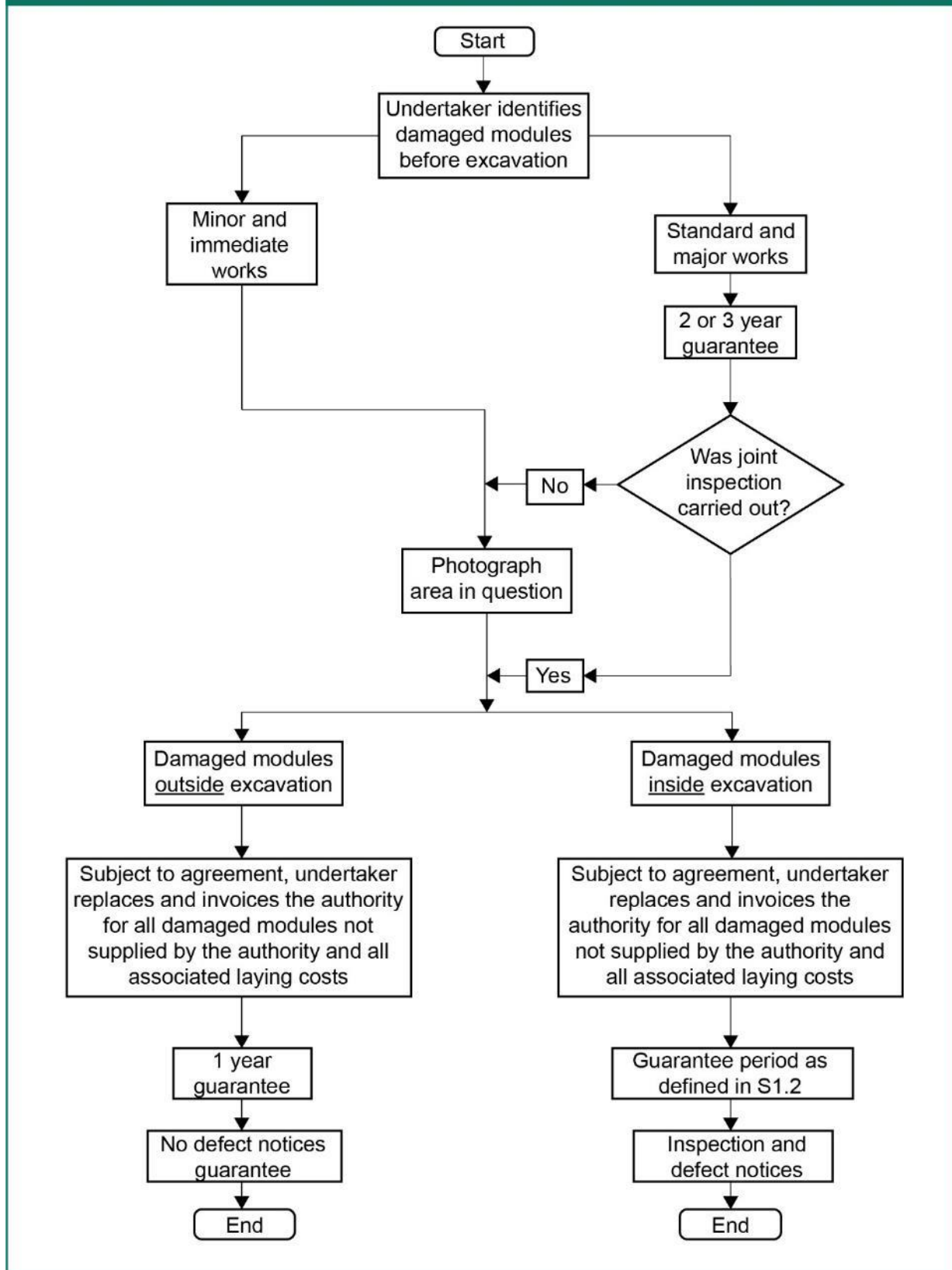
A12.4 Joint inspections and recovery of costs

- A12.4.1 Within limits of undertaker's works – Following notification from the undertaker, a joint inspection must be arranged before the commencement of all standard or major works to agree the extent of damaged, settled or deformed surfacing within the limits of the works. Where the authority does not provide suitable replacements to the undertaker in accordance with paragraph A12.3.1, it may contribute to the undertaker the sum notified by the undertaker as the cost of replacing the same.
- A12.4.2 Outside limits of undertaker's works – Following notification from the undertaker, a joint inspection must be arranged to agree the need and extent of any remedial measures outside of the limits of the undertaker's

works. An apportionment of the additional costs based on the relative areas of permanent reinstatement must be agreed. In the event of an authority failing to agree to meet a proportion of the costs of reinstating modules, the undertaker must proceed in accordance with S2.8.

A12.4.3 Prior joint inspections will usually be impractical for minor and immediate works. However, such works are usually small individual openings and a proportion of such works will be inspected by the authority within the sample inspection regime. On completion of all minor and immediate works, the undertaker must be free, and at its discretion subject to S2.8 and A12.3.3, to recover all reasonable costs from the authority according to the procedure illustrated in Figure A12.1.

Figure A12.1 Procedure for pre-existing damage to modular surfaces



NG1 Operational principles

NG1.1 General

- 1) The primary objective of this Code is to ensure that reinstatements are completed to a permanent standard and as soon as is practicable. Undertakers and authority personnel should work together, in close co-operation to achieve this.
- 2) Depending on the conditions, this may require a joint site inspection before starting work. Such joint pre-inspections may be of an informal nature, by agreement, and should be carried out at the earliest convenience of both parties. Where either party fails to attend any agreed pre-inspection, or where existing site conditions warrant concern, it is recommended that the undertaker retains a photographic record of the existing surfaces before starting work.
- 3) This Code may require a formal notification of circumstances or other requirements, depending on the conditions of the site, before starting works. Such pre-notifications should be issued at the earliest possible opportunity. Undertakers must comply with such notification issued at the street works notice stage and should make reasonable efforts to comply with any notification issued thereafter.
- 4) Where this Code allows several options, it is recommended, wherever practicable, to agree a preferred option from the alternatives available. This principle should be applied to all sections where alternatives are provided.

NG1.2 Guarantee period

- 1) Where an authority intends to resurface or reconstruct a section of road, the undertaker may complete any reinstatement to an alternative interim standard by agreement. The guarantee period must thereafter be waived unless the undertaker's reinstatement can be shown to be grossly substandard. It is expected that agreement to this procedure will be conditional upon all savings in costs made by not carrying out a permanent reinstatement being shared equally between undertaker and authority.
- 2) A reinstatement is deemed to be completed when fully compliant with this Code, this includes appropriate surfacing and road markings on the permanent carriageway, footway or cycle track reinstatement and restoration of verges including soil and seeding. If the reinstatement has been registered prior to completion, the guarantee period will be reset on compliant completion.

- 3) Where site circumstances are considered to militate against a successful permanent reinstatement, an interim period of up to a further 6 months may be adopted before it is necessary to complete the permanent reinstatement.
- 4) In designated high amenity locations and areas with high quality surfaces, there is benefit in completing the permanent reinstatement immediately or as expeditiously as possible. To facilitate a permanent reinstatement, materials need to be identified and ordered early in the works planning process. Advance notification through the normal co-ordination process is necessary to achieve this and the authority should assist the undertaker to locate sources of suitable similar or equivalent modules, especially if no stocks are available from the authority.

NG1.3 Road categories

- 1) Road categories 0 to 4 are based on the number of millions of standard axles (msa) carried by the road over a 20-year period. Reinstatements are designed on this basis.

Some roads that have been constructed in recent years (particularly new housing estate roads constructed under Section 38 of the Highways Act 1980) may have been designed and constructed to DMRB standards. In these cases, the authority must notify the undertaker, in advance of the works, and the undertaker must reinstate the excavation to match the existing construction thickness. It is not possible to match the engineering integrity of existing well-consolidated unbound layers with unbound reinstatement materials. Therefore, there may be significant differences between the existing carriageway construction and the requirements of the Code. The increased thickness of reinstatement materials compensates for this.

- 2) For any road, its msa rating gives the number of standard axle loads that it is expected to carry over a defined period of time. This msa rating is calculated using the following input data:
 - a) 24-hour annual average daily flow (AADF) of commercial vehicles in one direction. The use of AADF data in one direction, averaged from data in each direction, is recommended.
 - b) Average vehicle axle factor over a 20-year service life.
 - c) Actual sustained annual growth rate of commercial vehicles, averaged over several years, from valid census data.

This data, processed in accordance with DMRB procedures, provides the maximum number of commercial vehicles per day in each direction for all road types. Table NG1.1 has been prepared in accordance with the DMRB, showing the maximum AADF in one direction in commercial vehicles per day (cvd) for a single carriageway road, or for both lanes of a dual carriageway, for all road types and all likely traffic growth rates. Appropriate AADF rates for intermediate years within each five-year period can be calculated by interpolation.

Table NG1.1 – Maximum commercial vehicle traffic per road type						
Year of traffic count	Daily traffic flow - Commercial vehicles/day one direction - Single or dual carriageway					Average growth rate %
	Type 4	Type 3	Type 2	Type 1	Type 0	
0	66	240	638	1383	4499	0
5	66	240	638	1383	4499	
10	66	240	638	1383	4499	
15	66	240	638	1383	4499	
20	66	240	638	1383	4499	
0	60	217	578	1253	4079	1
5	62	226	601	1304	4245	
10	65	237	632	1370	4461	
15	68	249	664	1440	4689	
20	72	262	698	1514	4928	
0	54	196	521	1132	3690	2
5	58	212	564	1225	3994	
10	64	234	623	1353	4410	
15	71	259	687	1494	4869	
20	78	286	759	1649	5376	
0	49	176	469	1020	3333	3
5	55	198	528	1148	3751	
10	64	230	612	1331	4349	
15	74	266	709	1543	5041	
20	86	309	822	1789	5844	
0	43	157	420	916	3005	4
5	50	184	491	1072	3515	
10	61	223	598	1304	4277	
15	74	272	727	1586	5204	
20	91	331	885	1930	6331	
0	39	140	375	821	2704	5
5	47	170	456	998	3287	
10	61	317	582	1274	4195	
15	77	277	742	1626	5354	
20	99	354	948	2075	6833	
0	35	125	334	734	2430	6
5	44	158	422	927	3068	
10	59	211	564	1240	4105	
15	79	283	755	1660	5494	
20	106	378	1011	2221	7352	
0	31	111	297	655	2180	7
5	41	145	389	859	2858	
10	57	204	546	1204	4008	
15	80	286	766	1689	5621	
20	112	401	1074	2369	7884	
0	27	98	263	584	1953	8
5	37	133	358	795	2657	
10	54	196	526	1167	3904	
15	79	288	772	1715	5736	
20	117	423	1135	2520	8429	

Note: The datum for year 0 is the time of the reinstatement

3) Where the actual AADF rates for any road are significantly different for each direction and Table NG1.1 indicates different road types in each direction, the highest traffic category applies in both directions.

- 4) Where one-way traffic systems or other traffic management schemes result in multi-lane traffic, standard growth rate predictions and lane correction procedures may result in an inaccurate road classification overall. In such cases, whenever reasonably practical the flow of commercial vehicles should be monitored separately with traffic calculations completed for each traffic lane.
- 5) Where an existing road is near or beyond its service life and is expected to be re-constructed within the foreseeable future, a temporary re-classification of the road will usually be appropriate pending re-construction. Such temporary re-classifications should be undertaken by agreement between the parties involved. Similarly, where roads are expected to be re-constructed within the guarantee period of the reinstatement, it will usually be appropriate to amend methods, materials or performance requirements for those reinstatements by agreement.
- 6) The national network of roads carrying up to 125 msa within a 20-year period and classified as Types 0 to 4 roads according to the requirements of this Code will yield a distribution similar to that shown in Table NG1.2.

Table NG1.2 Estimated highway classification

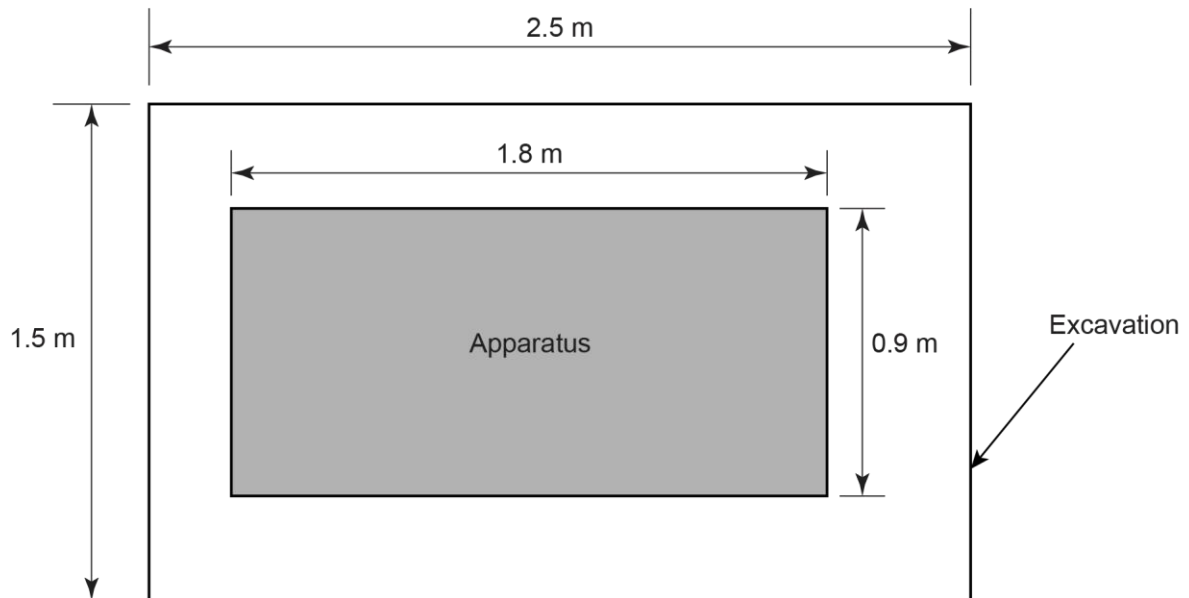
Road Type	% of total
0	< 1
1	< 1
2	< 5
3	< 9
4	> 84

- 7) It is expected that roads in any authority area will show a distribution similar to that shown in Table NG1.2, although there will be some local variations. In future years, there may be cases where traffic flows change to such a degree that re-classification will be necessary.

NG1.5 Excavation and trench categories

Figure NG1.1 shows how to measure the reinstatement area to classify the excavation category when apparatus is present at the surface.

Figure NG1.1 Classifying an excavation where surface apparatus is present



In this example:

$$A = \text{Excavation surface area}^* = 2.5 \times 1.5 = 3.75 \text{ m}^2$$

$$B = \text{Apparatus surface area} = 1.8 \times 0.9 = 1.62 \text{ m}^2$$

$$C = \text{Reinstatement surface area}^{**} = A - B = 2.13 \text{ m}^2$$

* to be recorded in register

** to categorise excavations as per S1.5

Excavation categories: Small excavations in road types 3 and 4 and in footways, footpaths and cycle tracks; other openings in road types 0, 1 and 2.

NG1.6 Alternative options

Alternative options may be progressed under A9. They include:

1) New materials

Research into new or improved reinstatement materials is often undertaken by various organisations and may produce materials that perform as well as or better than those given in this Code. To allow such materials to be proven by development testing, the materials and relevant layer thickness quoted in this Code may be amended or supplemented, subject to agreement.

2) Local materials

Materials may be available locally that have not been defined in any national specification but which, by experience, are known to give acceptable performance in service. In order to allow the use of such local materials, the materials and relevant layer thickness quoted in this Code may be amended or supplemented, subject to agreement.

3) Recycled materials

Recycled materials that do not meet the requirements of this Code (see S1.6.2) can be considered for use as ARMs.

The following is general guidance (not specifically related to ARMs) on recycling:

- a) Guidance on recycling asphalt containing tar can be found in "Managing Reclaimed Asphalt - Highways & Pavements" by ADEPT (<https://www.adeptnet.org.uk/system/files/documents/Managing%20Reclaimed%20Asphalt%20v2016-1a.pdf>). For information, there have been several technologies and material-based innovations within the Highways sector developed to recycle this type of material back into bound layers. Depending on scale/nature of works and the supply chain, some of these innovations may be applicable to street works and could be progressed via A9.
- b) Guidance on recycling on trench arisings can be found in "Recycled and stabilised materials in trench reinstatement" by WRAP (http://www.wrap.org.uk/sites/files/wrap/WAS005-002%20Utilities%20Evidence%20Base%20Report%20_2_.pdf). It provides evidence of material performance and explains where to find additional information.

4) Alternative compaction equipment (included under ATs)

Alternative compaction equipment not specifically permitted in S10 or A8 may be used provided it has been proven to be capable of achieving the performance requirements permitted in S10, A2 or A8. This should be progressed as an AT under A9.

- a) For all compaction plant not shown in A8, an approved operating procedure should be established by development testing in an appropriate trench environment with the relevant material options to meet the performance requirements permitted in S10, A2 or A8. The development testing may be verified by an independent, accredited laboratory.
- b) Where alternative compaction plant is intended to be used on more than one type of material, as defined in A8, an approved compaction procedure must be established for each intended category of material.

NG1.7 Immediate works

The minimum thickness of bituminous surfacing required by S1.7.1 for reinstating immediate works is 40 mm. A greater thickness may be required in areas subject to frequent or heavy traffic if further remedial works are to be avoided during the 10 days permitted duration of immediate works.

A temporary reinstatement may be used to fill an excavation before the apparatus is installed. The use of temporary reinstatement allows trafficking:

- 1) Before the bound layers are fully excavated and when the old backfill, surround and apparatus are in place; or
- 2) Where there is a delay in placing the bound layers of a permanent reinstatement.

Temporary reinstatements may be used:

- 1) For delays encountered during emergency or planned works (e.g. waiting for specialist staff or equipment to arrive)
- 2) On weekdays if work is limited to weekends
- 3) At weekends and public holidays if work is restricted to weekdays
- 4) For special events (e.g. parades, market days) when road plates are not appropriate.

The main factors to be considered for temporary reinstatements are trench volume, depth and shoring, materials availability, effect on apparatus, placement and compaction, removal and storage, asphalt specification and layer thickness.

NG1.8 Apparatus within the road structure

- 1) Apparatus may be present at a shallow depth in some road structures and special requirements may apply to their reinstatement. Both the undertaker and the authority are likely to have certain requirements and this Code may be altered or supplemented subject to agreement, to accommodate any such requirements.
- 2) Not all new apparatus needs to be installed to the full depth or width expected by this Code; an example is small diameter cabling and ducting for telecommunications, traffic controls, etc. This Code's requirements may be altered or supplemented subject to agreement, to accommodate these applications.

NG1.9 Geosynthetic materials, geotextiles and reinforcement grids

Where these materials are used the manufacturer's instructions must be followed, particularly in relation to appropriate overlaps, fixing and the like.

NG1.10 Trees

Prohibited, precautionary and permitted zones

PROHIBITED ZONE – 1 m from trunk. Excavations of any kind must not be undertaken within this zone unless full consultation with a highway authority tree officer is undertaken. Materials, plant and spoil must not be stored within this zone.

PRECAUTIONARY ZONE – beneath canopy or branch spread.

Mechanical plant should not be used when excavating in this zone. Precautions should be undertaken to protect any exposed roots. Materials, plant and spoil should not be stored within this zone. Consult with the highway authority tree officer if in any doubt.

PERMITTED ZONE – outside of precautionary zone. Excavation in this zone must be done with caution and the use of mechanical plant should be limited. Any exposed roots should be protected.

Precautions during excavation and reinstatement

1) THE PROHIBITED ZONE

Don't excavate within this zone.

Don't use any form of mechanical plant within this zone.

Don't store materials, plant or equipment within this zone.

Don't move plant or vehicles within this zone.

Don't lean materials against, or chain plant to, the trunk.

Do contact the highway authority tree officer or owner of the tree if excavation within this zone is unavoidable.

Do protect any exposed roots uncovered within this zone with dry sacking.

Do backfill with a suitable inert granular and top soil material mix as soon as possible on completion of works.

Do notify the highway authority tree officer or the tree's owner of any damage.

2) THE PRECAUTIONARY ZONE

Don't excavate with machinery. Where excavation is unavoidable within this zone excavate only by hand or use trenchless techniques.

Don't cut roots over 25 mm in diameter, unless advice has been sought from the highway authority tree officer.

Don't repeatedly move/use heavy mechanical plant except on hard standing.

Don't store spoil or building material, including chemicals and fuels, within this zone.

Do prune roots that have to be removed with a sharp tool (e.g. secateurs or handsaw). Make a clean cut and leave as small a wound as possible.

Do backfill the trench with an inert granular material and top soil mix. Compact the backfill with care around the retained roots. On non-highway sites backfill only with excavated soil.

Do protect any exposed roots with dry sacking, ensuring it is removed before backfilling.

Do notify the highway authority tree officer or the tree's owner of any damage.

3) THE PERMITTED ZONE

Don't cut roots over 25 mm in diameter unless advice has been sought from the highway authority tree officer.

Do use caution if it is necessary to operate mechanical plant within this zone.

Do prune roots which have to be removed with a sharp tool (e.g. secateurs or handsaw). Make a clean cut and leave as small a wound as possible.

Do protect any exposed roots with dry sacking, ensuring it is removed before backfilling.

Do notify the highway authority tree officer or the tree's owner of any damage.

NG2 Performance requirements

NG2.2 Surface profile

Edge depression

Pedestrians and two wheeled vehicles are particularly sensitive to edge depressions. Given that both modes use or cross roads, footways and cycle tracks, a single limit for all edge depressions is appropriate.

Surface depression

Excessive surface depressions reduce ride quality and give rise to noise and vibration. The maximum depth of surface depression within the area of a reinstatement is limited to approximately 2.5% of the width of reinstatement, which represents a mean slope of 1 in 20 (5% gradient). To prevent excessive areas of standing water, the maximum depth of a surface depression is limited to 25 mm regardless of the reinstatement width.

Surface crowning

Excessive surface crowning will reduce ride quality and give rise to noise and vibration. The maximum height of crowning within the area of a reinstatement is limited to approximately 2.5% of the width of the reinstatement, which represents a mean slope of 1 in 20 (5% gradient). To prevent excessive surface irregularity, the maximum height of crowning is limited to 25 mm regardless of the reinstatement width.

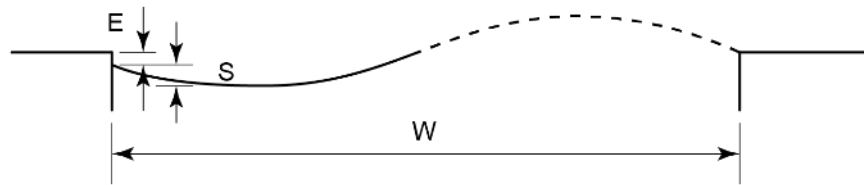
Combined defect

The intervention limits for surface depressions and surface crowning include a reduction in the intervention limit to 80% of the tabulated value, subject to a minimum of 10 mm, where surface depressions and/or crowning and/or edge depressions abut. The individual features must be measured, and the reduction applied, as follows:

1) Combination depressions

Where an edge depression abuts an area of surface depression, the area of abutting depression should be measured as shown in Figure NG2.1. Any surface crowning abutting an area of combined depressions should be measured separately, as shown in Figure NG2.2. The permitted depth of a combined depression is further limited if the depression results in standing water.

Figure NG2.1 Combination depressions

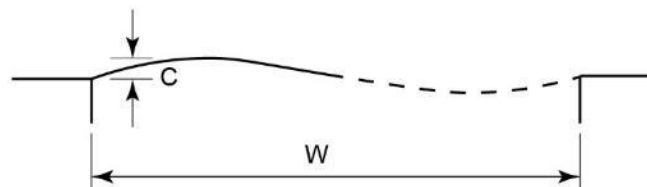


E is the edge depression contribution and S is the surface depression contribution. Once E and S are measured, they are compared with the combined defect intervention limits set in Table S2.1. If E or S is greater than the specified limit, intervention is needed.

2) Combination crowning

Where an area of surface crowning abuts an edge depression, a surface depression or any combination thereof, then the area of abutting crowning should be measured as shown in Figure NG2.2. The area of abutting depression should be measured separately, as shown in Figure NG2.1. The height of combination crowning should be reduced if it results in standing water.

Figure NG2.2 Combination crowning



C is the Surface crowning contribution. If this value is greater than the combined defect intervention limit specified in Table S2.2, intervention is needed.

NG2.3 Fixed features

Fixed features, e.g. kerbstones and related precast concrete products, channel blocks and drainage fixtures, surface boxes and ironware should be bedded on a sound foundation in accordance with the owner's requirements. In order to prevent excessive areas of standing water, it is necessary to set separate intervention limits for channel blocks, drainage fixtures, surface boxes and ironware.

NG2.4 Surface regularity

Where the use of a rolling straightedge is not permitted, the surface regularity must be assessed on an agreed basis. One method could be the use of a 2 m or 3 m straightedge.

NG2.5 Structural integrity

- 1) Reinstatement materials and compaction requirements have been specified in order to safeguard the pavement structure in and adjacent to the reinstatement. Any rapid or substantial settlement in a reinstatement may therefore indicate a potential reduction in the stability of the adjacent pavement structure, as well as potential defects in the reinstatement.
- 2) There will be cases in adverse circumstances where the correct application of this Code will still result in levels of settlement in the reinstatement that do not meet the requirements of S2.5 for structural integrity. For example, the type and condition of the adjacent ground or pavement structure may limit the degree of compaction that can be achieved, so influencing the amount of settlement that could occur.
- 3) Any engineering investigation is intended only to determine the likelihood and extent of any further settlement, and the most cost-effective and convenient method of restoring the structural stability and surface performance of failed sections of a reinstatement to a satisfactory condition.
- 4) In the case of large or deep excavations, it may be appropriate for the authority and the undertaker to agree an extended interim guarantee period, with additional interim surfacing materials laid to restore the running surface. When no further consolidation or settlement is considered likely, a permanent binder course and surface course may be laid, and the permanent guarantee period initiated. In any event, the location and extent of any re-excavation should be mutually agreed, taking full advantage of any bound materials already in place.

NG2.6 Skid resistance

- 1) Adequate skid resistance of the reinstated running surface must be maintained by selection of the polished stone value (PSV), aggregate abrasion value (AAV) and texture depth of the aggregate exposed at the road surface. The exposed aggregate may be precoated chippings rolled into the surface (HRA), coarse aggregate within the surface course, coated material to BS 594987, or any chippings or other aggregate applied in any form of surface dressing or slurry sealing treatment.
- 2) Reinstatements in smaller openings constitute a much lower degree of skidding risk, but the measurement of skid resistance, texture depth and surface regularity become progressively more difficult as the

reinstatement width reduces. However, material requirements and laying conditions remain unchanged and it is expected that the skid resistance of reinstatements in smaller openings will not be significantly different.

- 3) For the purposes of identifying reinstatement sites where the risk of skidding is potentially high (Site A, S2.6.3), sections of carriageway exceeding 10% gradient should be identified from existing steep hill warning signs or by notification from the authority. Similarly, bends of less than 100 m radius in roads where the speed limit is greater than 40 mph (65 km/h) should be identified from existing bend, double bend or chevron warning signs or by notification from the authority.
- 4) Given good site conditions, it is possible to obtain reasonably representative measurements of skid resistance and surface regularity on narrower reinstatements but amended test procedures and extra care are required. The Mini Texture Meter and Rolling Straightedge should always be fully contained within the limits of the reinstatement. The actual minimum practicable width for these instruments will depend on the trench alignment and radius of curvature. Measurements can be particularly difficult when testing on tight radius bends.
- 5) The undertaker should require the suppliers of bituminous materials to regularly supply details of the constituent materials within their bituminous mixtures and in particular, PSV/AAV test results for the coarse aggregate in surface course mixtures and the aggregate used for precoated chippings in HRA.
- 6) Past use of Table S2.7 indicates that the minimum values noted are appropriate in most cases.
- 7) The requirement for PSV only relates to the directly trafficked coarse aggregate size fraction, i.e. feedstock into the asphalt production retained on 4 mm sieve. Research for the use of 53 PSV aggregate was based on crushed hard stone. Some sources of coarse aggregate limestone can have a PSV of 53 or higher. These sources should not be used in without an evidenced in-service track record. The historic track record would be versus the 3rd Edition requirement of 55 PSV. The restriction on limestone should not be misinterpreted to prohibit its use as a fine aggregate, filler or in any other application other than the coarse aggregate in the running surface. For chipped HRA applications this requirement only relates to the chippings.

NG2.8 Works in deteriorated or distressed areas

Flexible footpaths, footways and cycle tracks can become relatively brittle with age. An aged asphalt surface may be prone to damage during utility or highway works so a collaborative approach is recommended to develop solutions agreeable to all parties. The authority might agree to meet the costs of reinstating an area of surfacing greater than that which would be required in normal circumstances. A joint site walkover is recommended.

Figure NG2.3 provides guidance on how to assess the surface condition and establish if it is visibly distressed.

Figure NG2.3 Examples of surface condition		
Flexible footway		
Good condition	Moderate condition	Poor condition
		
Rigid footway		
Good condition	Poor condition	
		
Modular surface		
Good condition	Moderate condition	Poor condition
		
Carriageway		
Good condition	Moderate condition	Poor condition
		

The undertaker should include which specification requirement (or requirements) may not be achieved and the respective reasons for each non-compliance. Some of the non-compliances that the undertaker should record may be:

- 1) modification of method of compaction during reinstatement works owing to evident cracking of the adjacent surfacing or lack of confinement offered by the surrounding structure;
- 2) difficulty in achieving edge regularity owing to adjacent surface cracking and breaking;
- 3) any post construction performance requirements that may not comply during the guarantee period, for example edge depression or surface regularity.

NG3 Excavation

NG3.1 Breaking the surface

High amenity and natural materials surfaces

- 1) When excavating modular construction within high amenity areas, or natural materials within any footway area (as defined in S1.4), the undertaker must lift the existing modules carefully and store for re-use.
- 2) More recent construction tolerances of existing modules in NG3.1(1) often make it unlikely that the first module in an individual excavation can be lifted without the module itself being damaged. In such circumstances, this damage may be inevitable, but damage should be limited to only one module in an individual excavation.

Aesthetics

The shape and line of larger trenches and their reinstatement should have regard wherever possible to the aesthetic appearance of the reinstatement and its impact on the street scene.

NG3.2 Excavation

- 1) HSG 150 “Health and Safety in Construction” gives guidance to those carrying out excavations.
- 2) Where possible, all excavations should be planned before commencement of works on site.
- 3) Work must be undertaken and supervised by competent personnel.

NG3.4 Side support

There must be sufficient quantities of appropriate materials available to provide safe trench support, if required.

NG4 Surround to apparatus

NG4.1 General

- 1) Undertakers often need to use a specific type or quality of material and special protective components in the immediate vicinity of certain types of underground apparatus. This material is usually referred to as the surround to the apparatus and may include fine unbound granular materials (usually termed 'fine fill'), bound materials, tiles, covers, tubular shields, etc., or any combination thereof. The resulting surround may be required for a variety of reasons, including structural support, low corrosion potential, protection for non-metallic materials or special coatings, etc.
- 2) The nature of the undertaker's apparatus, and the protective features of the surround, especially any fine unbound granular materials used within the surround, may impose additional restrictions on the type of compaction equipment that can be used and the necessary operating procedures. However, the entire surround will effectively form a foundation structure for the remainder of the reinstatement and must be capable of providing adequate support for all loading imposed on the reinstatement surface, as well as the weight of the reinstatement structure.
- 3) In selecting material for the surround to apparatus, undertakers should be mindful of the potential for the migration of fines from the adjacent ground or the overlying backfill into any surround material that is open-textured. Such migration will normally result in settlement of the adjacent ground and backfill. Migration of fines can be prevented by using a close textured surround or by enclosing the surround within a suitable filter membrane.
- 4) An ARM proposed for use as the surround to apparatus should have been approved for this specific application, which may also require consideration of different types of apparatus.

NG5 Backfill

NG5.1 Backfill material classification

The assumed limiting performance of the five classes of backfill material defined in A1 is shown in Table NG5.1.

Backfill material class	Material performance % CBR
A	Over 15
B	7 to 15
C	4 to 7
D	2 to 4
E	Less than 2

Modified Type 1F Unbound Mixture is the preferred option in narrow trenches and small openings. It has a lower nominal aggregate size compared with Type 1 Unbound Mixtures, making it more resistant to segregation during transport and placement. Performance within a trench will be comparable with Type 1 Unbound Mixtures.

NG5.3 Additional requirements

Frost heave susceptibility

The frost heave test described in BS 812-124 (as amended by MCHW Clause 801.8) is costly and time consuming and is not suitable for routine on-site control checks. The test is primarily intended as a method to establish whether an aggregate from a particular source is likely to be frost susceptible when used in road construction. Material for the frost heave test must be representative of the source or sub-grade encountered. Authorities usually maintain a list of “Approved Suppliers of Non-frost Susceptible Materials” and should have knowledge of frost susceptible sub-grades in their locality.

The following notes on identification of potentially frost susceptible material are for guidance but are not exhaustive:

- 1) Clay materials can be regarded as non-frost susceptible, particularly when the plasticity index is greater than 15%. Clay/silt mixtures are more difficult to assess and are likely to be of marginal frost susceptibility.
- 2) Silts, particularly those with more than 10% passing a 0.063 mm BS sieve size, are likely to be frost susceptible.

- 3) Cohesive/granular materials will often be frost susceptible; the quantity and type of granular aggregate and, to a lesser degree, the silt fraction are the controlling factors. If the aggregate is frost susceptible it is very likely that the mixture will also be frost susceptible.
- 4) Granular materials with more than 10% passing a 0.063 mm BS sieve size have a high potential for frost susceptibility, and granular materials with more than 12% passing 0.063 mm are likely to be frost susceptible.
- 5) All crushed chalks are frost susceptible. The amount of frost heave will increase with the saturation moisture content of the chalk.
- 6) Oolitic and magnesium limestones are likely to be frost susceptible, particularly those where the aggregate saturation moisture content exceeds 3.5%.
- 7) Hard carboniferous limestones are unlikely to be frost susceptible unless they have been contaminated with clay or have more than 12% passing 0.063 mm.
- 8) Crushed granites will only be frost susceptible if the percentage passing 0.063 mm exceeds 12% and is plastic.
- 9) 'As dug' sands and gravels are frequently frost susceptible especially if the percentage passing 0.063 mm BS sieve size is greater than 12% or if it is plastic. Sands and gravels won by "wet working" techniques are unlikely to be frost susceptible unless contaminated by a clay or a high silt fraction.

NG6 Flexible and composite roads

NG6.2 Sub-base reinstatement

- 1) It is expected that a bituminous sub-base would only be selected where the base is also bituminous.
- 2) When placing bituminous material directly onto backfill it is important to ensure that the exposed surface of the backfill has been compacted. This operation is essential to minimise the risk of a build-up of pore water pressure causing the subgrade to become spongy. It is also imperative that construction is phased such that excavated areas are covered on the same day with the first layer of bituminous material to prevent the ingress of water. Care should be taken in compacting this first layer. If pore water pressure builds up in the backfill at this stage, then rolling should cease and the material left overnight, or longer if necessary, before placing of any further layers.
- 3) The condition of sub-base material can be assessed using field identification test No. 3 in A1.

NG6.3 Base reinstatement

CBGM base in flexible and composite roads

CBGM base has a slump of zero and can be suitable for immediate overlay depending on the aggregate grading and interlock before any significant strength gain during curing. The relatively low cement-water ratio also means this type of material has low potential for shrinkage during curing. Conversely, concrete and wet lean concrete typically require strength gain to enable overlay without damaging the surface.

Overlaid modular layers

- 1) This Code permits the re-use of cobbles and setts for the reinstatement of the relevant layer. However, it is often extremely difficult to achieve a performance from reinstatements similar to that of the original, i.e. a well interlocked and 'stress hardened' layer. Failure to achieve this structural stiffness could result in failure of the reinstatement and particularly any surfacing materials laid thereon.
- 2) The Code does not permit the re-use of penning, in which modules are laid upright in an interlocking manner, thus exhibiting greater stiffness than an equivalent layer of cobbles or setts would.

NG6.4 Surface reinstatement

Hot rolled asphalt surfaces

- 1) HRA design mixtures give better resistance to deformation than recipe mixtures where queuing of heavy traffic is likely to occur, and it may be more economical to lay.
- 2) Type C mixtures use fine aggregates of a coarser grading than Type F mixtures, usually associated with the use of crushed rock fines. Such mixtures tend to be stiffer, more prone to fretting and less well suited to the reinstatement of small openings.
- 3) HRA 55/14F is a high stone content asphalt (HSC). HSC asphalts can be difficult to hand-lay and are relatively prone to segregation. If these risks are not mitigated, they can lead to problems including failure at joints and surface fretting. Consideration should therefore be given to the options below:
 - a) Reduce nominal aggregate size.
 - b) Softer binder grade.
 - c) Use of permitted materials in A2, by agreement with the authority.

Stone mastic asphalt (SMA) and thin surface course systems

Suitability of a SMA or TSCS for reinstatement works its appropriateness for small volume works and hand laying. This is a consideration when designing for maintenance in highways and when the authority is requested to identify a suitable material for reinstatements.

SMA and TSCS can be difficult to hand-lay, especially if they contain highly modified PMBs. If risks related to hand-laying are not mitigated, they can lead to problems including failure at joints and surface fretting. As a risk mitigation, a reduction in nominal aggregate size is included in S6.4 for SMA and TSCS. The suitability and availability of SMA or TSCS also need to be considered

Considerations include availability of a low volume supply of mixtures that use specified PMBs (link to tankage and supply from the asphalt plant) and whether any modifications to the mix can be adopted, such as workability agents, to mitigate installation risks. The underlying logic is that the performance of the reinstated surface is not detrimentally impacted and that materials are available for the works.

Increasing the surface area of reinstatements to enable use of paved material options only should be avoided unless by mutual agreement.

Other bituminous materials

Highway authority requirements for the use of specific materials within street works need to take into account the suitability of the material. In general terms this may mean that a highway authority specification for a SMA (or other material) that has been designed for paver installed resurfacing works may not be suitable for use within trench reinstatements without modification. NG6.4 gives guidance on this topic and the underlying logic is that the performance of the reinstatement

surface is not detrimentally affected and that materials are available for the works.

High friction surfaces

- 1) As high friction surfaces are usually laid for safety reasons they should be reinstated as soon as is practicable.
- 2) Performance on concrete may not be as good as on bituminous surfaces and the suitability of a system should be checked by reference to its Product Acceptance Scheme certificate.
- 3) Suppliers of some high friction surfacing systems may have specific requirements relating to the condition of the surface on which it is to be applied. Guidance on this should be sought either from the supplier or the Product Acceptance Scheme certificate.
- 4) It is recommended that high friction surfacing systems are applied to a surface course that has been trafficked for some weeks. This is to help prevent cracking of the surface course induced by the application of a newly laid high friction surface.

Porous asphalt

- 1) Edge sealing requirements specified in S6.8.7 may not be appropriate with porous asphalts because the free-flow characteristics of the material may be impeded.
- 2) Some application rates in this Code are quoted in kg/m² of residual bitumen. This differs from rates in l/m². For example, the rate of 0.50 kg/m² residual bitumen equates approximately to 1.2 l/m² of K1-40 or 0.80 l/m² of K1-60 emulsion.

Coloured surfaces

- 1) Coloured surfaces are sometimes used for marking bus lanes, accident prevention measures, traffic prioritisation schemes, etc. The use of warning signs, e.g. "Temporary Road Surface", should be considered until the coloured surface can be restored.
- 2) It may not be possible to obtain surfaces in a wide selection of colours so authorities may have to accept limitations in colour matching, especially as colours fade with age.

Other specialist surfacing materials

Texture depth requirements specified in S2.6.2 may not be appropriate for the increasing number of specialist surfacing materials currently being used by some authorities.

Surface treatments

In all roads, where the overall quality of existing surface treatments is to a high standard, it may be difficult to produce small openings or narrow trenches with surface dressings or other surface treatments that closely match the existing adjacent surfaces. Under such circumstances, if the requirement to reapply the surface treatment is only for aesthetic

reasons, some localised variation in surface appearance should be acceptable to the authority.

NG6.5 Reinstatement of small openings and narrow trenches

Compaction

The risk of material cooling is relatively high for narrow reinstatements. Depending on the specifics of the asphalt material, relatively fast cooling can lead to difficulty in achieving the required level of compaction, and this can result in reduced durability of asphalt materials. Therefore, dependent on the site specifics, resourcing to ensure compaction of asphalt materials in narrow trenches may require additional consideration. Examples of this includes material choice and working practice (number of operatives).

An alternative is hand compaction; however, it is not the preferred method and should only be used where conventional compaction equipment cannot be used, and only for the minimum possible proportion of the reinstatement. Where narrow trenches or small openings make compaction impracticable, and where conventional equipment cannot be used owing to existing restrictions, PMMA is preferred.

Materials

PMMA are recommended when compaction cannot be readily achieved with conventional materials or equipment owing to existing restrictions (kerbs, ironwork, street furniture, narrow trenches, etc).

In some systems pre-manufactured PMMA blocks can be lightly bedded into the hot PMMA. Sufficient space between the blocks is needed to allow the surrounding hotter material to flow around the blocks and fill any voids. For deeper excavations, extra layers of PMMA and blocks are used as required.

When all the blocks have been placed, the material is allowed to cool for 10 minutes. The excavation is typically filled to within 30 to 50 mm of the finished carriageway surface to allow final installation of the PMMA surfacing. The following information should typically be retained by the undertaker in relation to any potential future defects:

- 1) Confirmation from the certificate holder that the installer is approved to install the proposed system.
- 2) A copy of the Method Statement in line with the certificate for the chosen system.
- 3) A copy of the material data sheets and/or company COSHH sheets.
- 4) Results of all quality control checks carried out on site by the undertaker and quality assurance information compiled in accordance with the requirements of the certificate, including results from surveillance.

NG6.6 Micro trenches

General

Micro trenches are generally used for major works. Apparatus installed in a micro trench might comprise:

- 1) Mini-ducts, single or multiple, or
- 2) Directly buried cables, single or multiple.

After installation, ducts have cables installed inside them. Cable installation operations should not impact upon the reinstated micro trench.

Any surface cracking or other evidence of distress is likely to result in significant overbreak during excavation. In this case it is likely that reinstatement would be required using narrow trenching.

When planning the position of the micro trench, safety and ride quality for cyclists should be considered.

Excavation/cleaning

The method of cutting/excavation used for micro trenching can have a significant impact on the ability to achieve an effective reinstatement. The greatest threat to effective reinstatement is the presence of excess moisture. For this reason, a dry cutting process using a vacuum recovery system for the arisings is preferred.

The minimum combined thickness of courses 1, 2 and 3 above the apparatus has been specified for safety and technical reasons. This includes ensuring a minimum cover of the apparatus to remove the risk of strikes when milling the surface and binder course in maintenance operations.

Subsequent excavation and reinstatement by others

The following sub-paragraphs provide guidance to other undertakers or street authorities where their excavations expose ducts or cables in micro trenches.

During excavation, it is expected that the original reinstatement materials above the ducts/cables (materials 1 and 2 as per main paragraph 4) will be removed.

The exposed duct/cable will require temporary support and protection in the same manner as any other exposed service - a small amount of flexibility in the exposed duct/cable will be apparent at the time of excavation.

It is recommended that the owner of the duct/cable should specify that the exposed length should be sleeved inside split steel ducts at this point.

The steel ducts should be made freely available by the owner, and their use will provide:

- 1) Increased physical protection during these subsequent reinstatement operations;

- 2) Increased service traceability ahead of further re-excavation on future works;
- 3) Increased physical protection during the further re-excavation (as coloured material 1 will not have been reinstated).

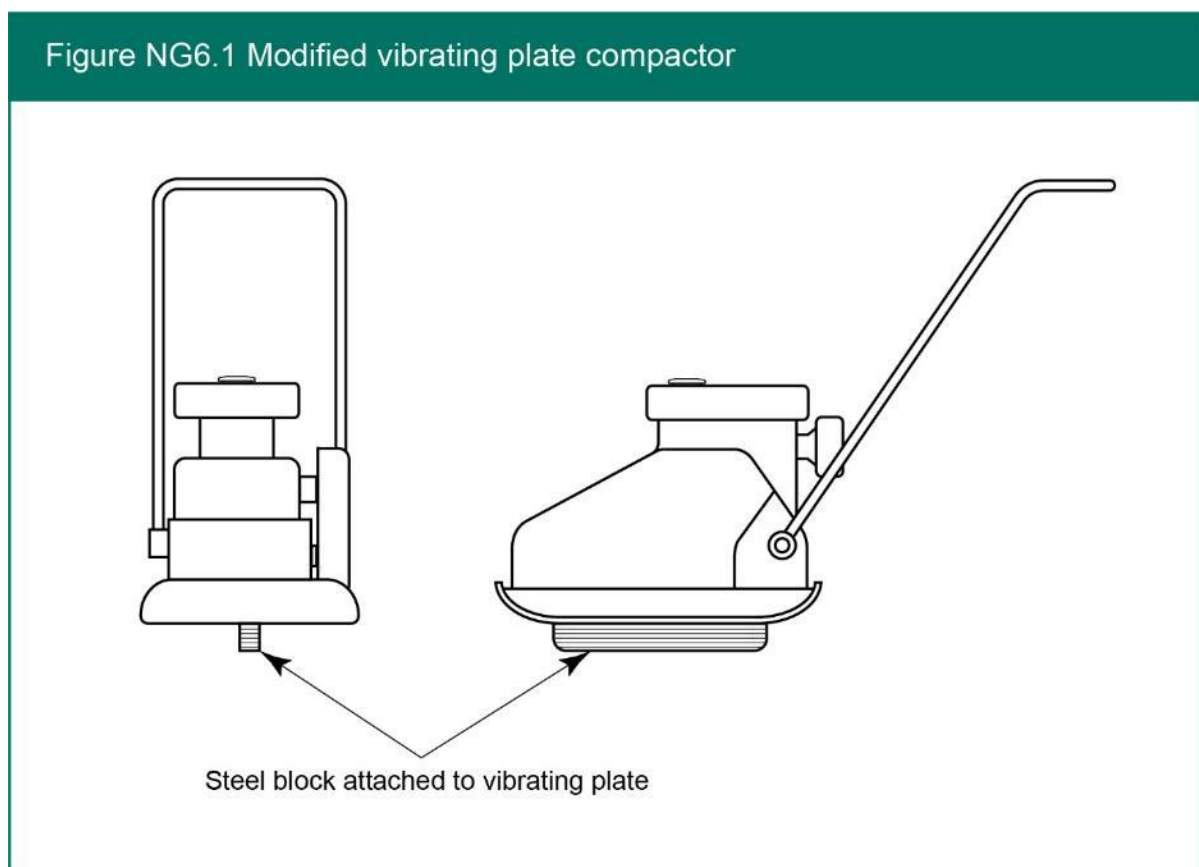
Reinstatement of the subsequent excavation will require the careful deposition and compaction of lower layer granular materials, in a similar fashion to current practices when working around other services.

The small amount of flexibility in the exposed duct/cable is unlikely to allow the line and depth of the duct/cable to deviate greatly from its original as-laid position. As a result, some depth of binder course materials will require careful deposition and compaction to the underside of the sleeved duct/cable.

In the same manner, the next lift of the binder course above the sleeved duct/cable will require careful deposition and compaction. However, with the added protection of the split steel ducts, normal compaction should be achieved, again in a similar fashion to current practices when working around other services in the bound asphalt layers.

Installation

In Figure NG6.1 an example of a suitable compaction tool is shown. This is for guidance only and other modified equipment to achieve compaction may be used.



For course 3, nominal means the approximate dimension by which a material is generally called or sold in trade, but which differs from the actual dimension.

Materials specification

Any alternative materials will be progressed via A9 and potentially then also supported by a Product Acceptance Scheme certificate. Desirable properties include skid resistance of the surface, flowability during reinstatement, adhesion of the product to the reinstatement edges post curing, mechanical performance under loading, volumetric stability during its in-service life and durability (including frost resistance and resistance to water)

NG6.7 Large diameter cores

Multiple interlocking or closely spaced large diameter cores have the potential to create areas of weakness in the pavement. This will depend on several site-specific factors including location of the core, composition of the pavement, and the coring arrangement. The authority should not withhold the use of multiple cores if it is proven to be common practice.

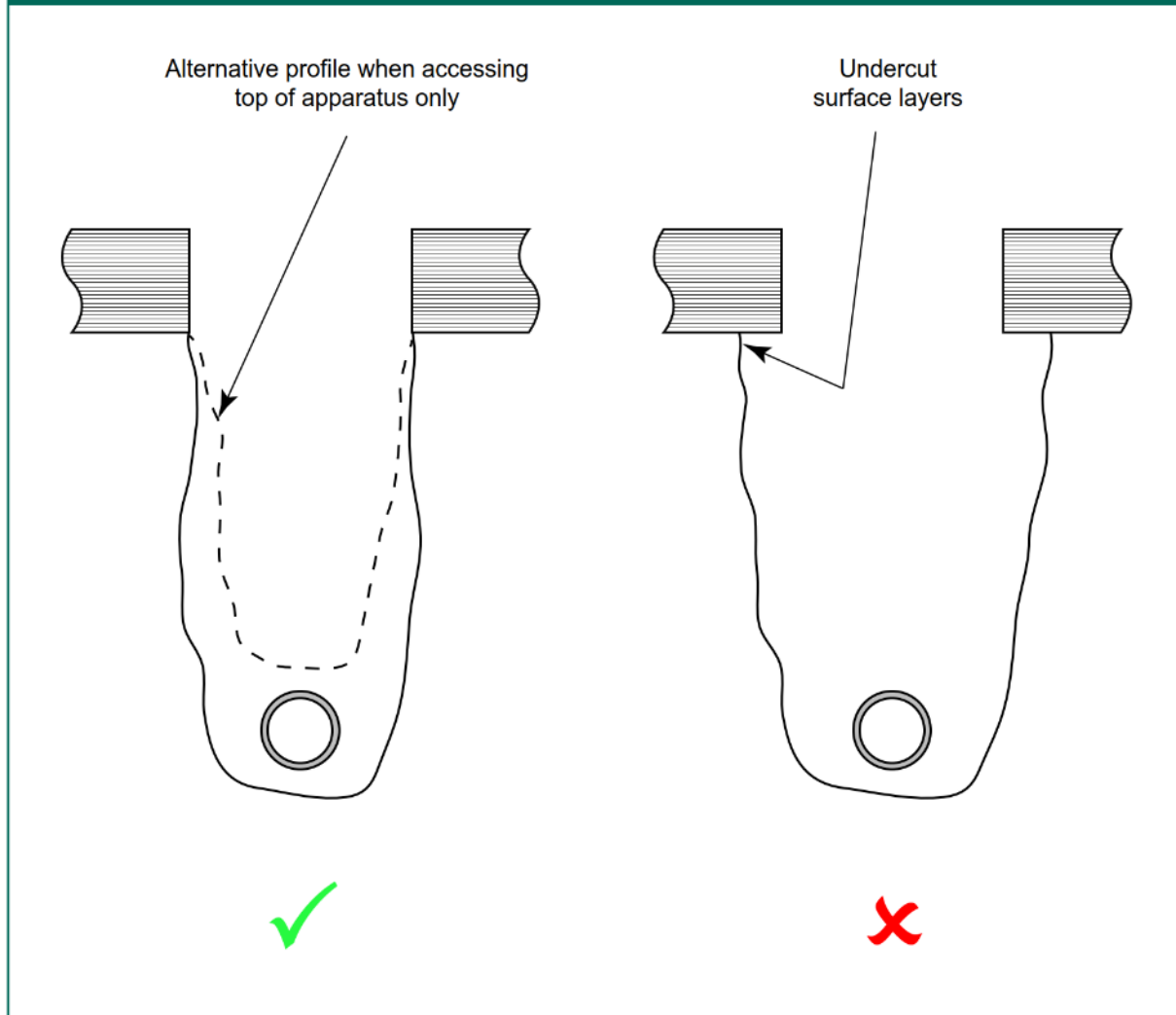
All measurements between core locations are taken as a horizontal measurement between the two closest edges of the cores.

Coring and removal of the large diameter core

Verticality of the core barrel set up on site and the specifics of the coring plant have an influence on the potential to damage the surrounding surface.

Figure NG6.2 shows a schematic cross section of acceptable and unacceptable excavations. The assumption behind not being able to complete the reinstatement in accordance with S6.7.17 is that there is a risk that compaction will not be achieved if structure has been undermined. This is particularly critical in the zone directly supporting the bound layer adjacent to the core hole. It may be that a suitable flowable material (e.g. PMMA or FCR or A9 FSMR) could be used as an alternative in this scenario.

NG6.2 Large core excavation limits



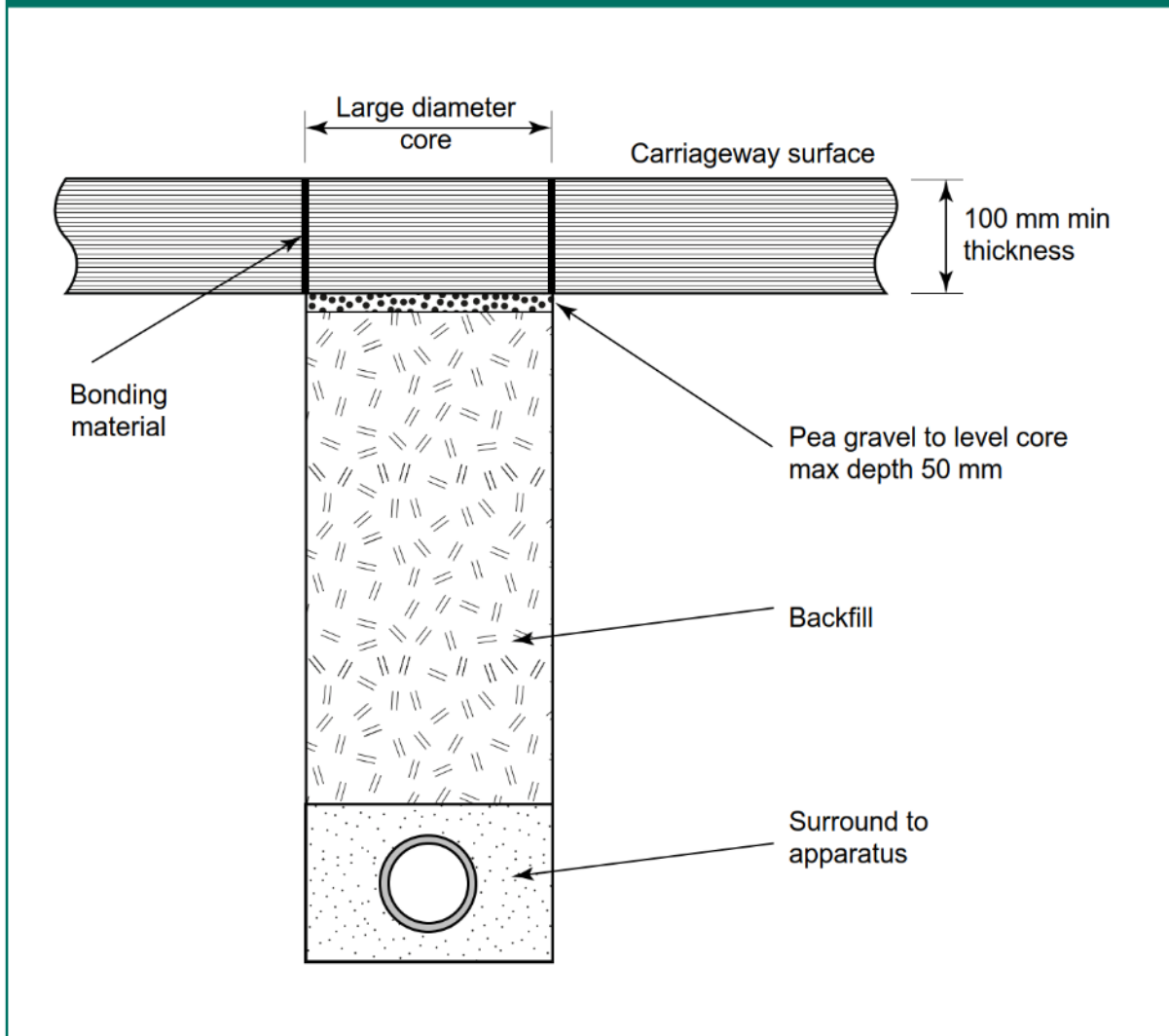
Materials

When reinstating using the core, the bonding material needs to fill the annular space between the core and the hole to securely bond the core to the existing surface. In addition, the bonding material must be volumetrically stable and resistant to cracking or water penetration.

Backfill and compaction

Figure NG6.3 shows typical large core reinstatement using pea gravel for levelling the core during the reinstatement process.

Figure NGA6.3 Typical large core reinstatement



Core reinstatement and bonding

Typical considerations in the Method Statement for a large diameter core reinstatement would include that:

- 1) The core must sit horizontally within the hole, 25 mm below the surrounding carriageway surface with a nominal gap of 7 mm between the core and the hole.
- 2) An alignment clip can be used to aid this process.
- 3) The core is then removed, and a sufficient quantity of bonding material is applied to ensure the 100 mm pilot core and the gap between the core and the hole is completely filled. There must be no visible voids present.
- 4) A satisfactory result is confirmed by the presence of a small amount of bonding material extruding to the surface.
- 5) When suitably cured, the excess material must be removed from the surface and adjacent areas. The reinstated core must be left in an acceptable visible condition. If power washing or similar processes are

applied, care should be taken to avoid washing contaminated fluids into drainage systems.

NG6.8 Base and edge preparation

Base preparation

- 1) Bond coating materials are generally based on rapid curing anionic or cationic bitumen emulsions to BS 434, with approximately 40% bitumen content. New bond coating materials are becoming available and the trial use of more modern variants is recommended.
- 2) Application rates in this Code are quoted in kg/m² of residual bitumen. This differs from the previous Code which quoted rates in l/m² of total emulsion. For example, the rate of 0.15 kg/m² residual bitumen equates approximately to 0.35 l/m² of 1-40 or 0.25 l/m² of K1-60 emulsion.
- 3) Further guidance on application of bond coats can be found in BS 594987.

Edge preparation

The shape of the trench should not hinder the compaction of material at the reinstatement perimeter. When angles less than 90° are used, special care must be taken to comply with compaction requirements. These include use of appropriately shaped hand compaction tools.

Edge sealant materials are generally based on rapid curing bitumen emulsions to BS EN 13808, typically in the range 40 to 100 pen and approximately 70% bitumen content, or hot bitumen to BS EN 12591 typically 50 or 70 penetration grade. An increasing number of high build and rubberised edge sealants are becoming available and, in general, are preferred. Alternatives to these materials exist and if there are any doubts as to their effectiveness they may be used on a trial basis (A9).

When using edge sealant materials, strict adherence to manufacturer's instructions is essential. Depending on weather conditions, brushed sealant drying times may vary between 5 minutes and 2 hours, whilst spray sealant times may vary from 1 to 15 minutes before reinstatement can take place.

Additionally, before application:

- 1) All excess water and loose material should be removed from the cut faces of the reinstatement;
- 2) All bound vertical edges must be clean and free from slurry and dust etc. with the stone in the existing layers clearly visible.

The following case study data sheets illustrate the results of edge sealant application under different edge conditions:

- 1) Figure NG6.4: Example 1 – dry and clean;
- 2) Figure NG6.5: Example 2 – wet;
- 3) Figure NG6.6: Example 3 – dirty and damp.

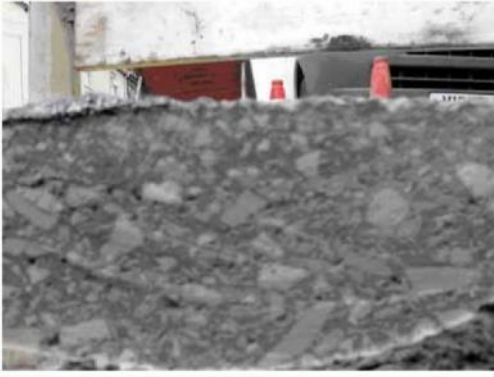



Figure NG6.4 Example 1	
A	 <p>EXAMPLE 1 DRY/CLEAN EDGE CONDITIONS GOOD BONDING [Weather: dry, warm, overcast]</p>
B	 <p>Photo A: Clean and dry saw-cut edge.</p> <p>Photo B: First application of edge sealant or edge sealing system.</p>
C	 <p>Photo C: Second application of edge sealant or edge sealing system to top of reinstatement edge following compaction of first reinstatement lift.</p> <p>Photo D – Core Comments:</p> <ul style="list-style-type: none"> • Core taken through joint shows that edge sealant or edge sealing system has adhered to vertical edge; • A good bond observed between reinstatement and adjacent surfacing.
D	 <p>Overall Comments: Reinstatement edge was clean, free of dust or 'caked' saw coolant.</p>

Figure NG6.5 Example 2









	<p>A</p>	<p>EXAMPLE 2 WET EDGE CONDITIONS POOR BONDING [Weather: dry, hot sunny]</p>
	<p>B</p>	<p>Photo A Coating of wet slurry on saw-cut edge.</p> <p>Photo B: First application of edge sealant or edge sealing system. [Only 5 minutes of drying time allowed before reinstatement commenced].</p> <p>Photo C: Second application of edge sealant or edge sealing system to top of reinstatement edge following compaction of first reinstatement lift. [Only 2 minutes of drying time allowed before reinstatement commenced].</p>
	<p>C</p>	<p>Photo D – Core Comments:</p> <ul style="list-style-type: none"> • Core taken through joint shows that the edge sealant or edge sealing system has not adhered to vertical edge; • No bond observed between reinstatement and adjacent surfacing.
	<p>D</p>	<p>Overall Comments:</p> <ul style="list-style-type: none"> • Reinstatement edge should have been washed and substantially dried before application of spray sealant; • Allowed drying time does not conform with manufacturer's instructions; • Incorrect application of edge sealant or edge sealing system could permit water penetration into joint, potentially leading to early life edge deterioration, settlement of trench and future (avoidable) defects.

Figure NG6.6 Example 3

	<p>A</p> <p>EXAMPLE 3 DIRTY/DAMP EDGE CONDITIONS POOR BONDING [Weather: light rain]</p>
	<p>B</p> <p>Photo A Coating of wet slurry on saw-cut edge.</p> <p>Photo B: First application of edge sealant or edge sealing system. [Only 5 minutes of drying time allowed before reinstatement commenced].</p> <p>Photo C: Second application of edge sealant or edge sealing system to top of reinstatement edge following compaction of first reinstatement lift. [Only 2 minutes of drying time allowed before reinstatement commenced].</p>
	<p>C</p> <p>Photo D – Core Comments:</p> <ul style="list-style-type: none"> • Core taken through joint shows that the edge sealant or edge sealing system has not adhered to vertical edge; • No bond observed between reinstatement and adjacent surfacing.
	<p>D</p> <p>Overall Comments:</p> <ul style="list-style-type: none"> • Reinstatement edge should have been washed and substantially dried before application of spray sealant; • Allowed drying time does not conform with manufacturer's instructions; • Incorrect application of edge sealant or edge sealing system could permit water penetration into joint, potentially leading to early life edge deterioration, settlement of trench and future (avoidable) defects.

Overbanding assists in preventing water ingress and seals the edge of a reinstatement at the surface. Skid resistance can be measured using the pendulum test. Overbanding can be detrimental if it creates localised ponding.

The following information is typically retained by the undertaker in relation to any potential future defects:

- 1) Confirmation from the certificate holder that the installer is approved for installation of their proposed system.
- 2) A copy of the Method Statement in line with the certificate for the chosen system.
- 3) A copy of the material data sheets and/or company COSHH sheets.
- 4) The results of all quality control checks carried out on site by the undertaker and quality assurance information compiled in accordance with the requirements of the Product Acceptance Scheme certificate, including results from surveillance visits must be made available on request.

The fact that a core may separate is not, on its own, evidence that no edge sealant has been used or of a lack of bond between layers. It may be due to damage during coring. Any investigation into bond should consider risk mitigation to avoid damage during the sampling and test preparation process.

NG7 Rigid and modular roads

NG7.1 Reinstatement methods

- 1) This Code applies to all rigid roads up to 125 msa traffic flow. All rigid roads with existing traffic flows exceeding 30 msa must be identified by the authority, before the commencement of works, so that reinstatement requirements can be agreed.
- 2) Some modern concrete roads constructed in accordance with current Government standards and specifications may incorporate special design philosophies that are beyond the scope of this Code. Similarly, there may be other existing rigid road designs that will also require the use of particular reinstatement methods. Such roads must also be identified by the authority, before the commencement of works, so that reinstatement requirements can be agreed.

NG7.3 Concrete road slab reinstatement

For small openings a proprietary C32/40 site-batched concrete may be used.

Considerations related to pavement details

Concrete pavements can be classified as jointed unreinforced concrete (URC), jointed reinforced concrete (JRC) and continuous reinforced concrete pavement (CRCP). URC slabs are typically up to 5 m long, JRC slabs are typically between 5 m and 25 m, and CRCP has no joints but will develop fine transverse cracks at 2 m to 3 m intervals. Dowel bars are used to transfer traffic load across transverse joints and tie bars are used in longitudinal joints between lanes.

Reinforcement for long trenches with a length to width ratio greater than 3:2 is typically located between 60 mm and 90 mm below the concrete surface and comprises steel mesh (typically A393 for roads). This mesh minimises the potential for cracking during curing and is not a structural mesh. Shallower (lower cover) reinforcement requires consideration of potential corrosion associated with chlorides. Sources of chlorides include the use of de-icing salt during winter maintenance. Guidance can be found in BS 8500-1.

Additional reinforcement in the concrete surround, should be considered around ironwork and other features to reduce the risk of sympathetic cracking within the reinstatement (see MCHW Volume 3 Series C for guidance).

It is envisaged that the requirement to include transverse joints within the reinstatement would be needed for works that cut across 5 or more concrete bays, or where there is a concern that the dowelled reinstatement will lock up the concrete pavement (i.e. prevent the pavement from contracting and expanding normally) increasing the risk of cracking associated with loading or sympathetic cracking.

NG7.5 Edge support and preparation

Using a grout into the back of the hole ensures that the material flows out around each bar, fully encasing it. Do not coat one end of the bar with grout or epoxy and then insert the bar into the hole – the air pressure inside the hole will force the grouting material back out of the hole, leaving a void around the bar.

For guidance, omission of dowels should be based on the consideration any load transfer requirements, geometry and size of the reinstatement. Consideration of the use of low shrinkage concretes, including proprietary products for concrete repair, is recommended for discussion in this case.

NG7.6 Reinforcement

Long and narrow concrete slabs and reinstatements tend to crack more than square ones. Mitigation of this risk typically includes the use of a mesh in the upper part of the slab. Reinstatement mesh is preferred to bar reinforcement for ease of installation.

Where there is any conflict at corners of reinforced concrete reinstatements then precedence for reinforcement positioning should be given in line with traffic flow.

Recoding the type of reinforcement within an excavation forms part of any quality assurance process. This can be done by taking photographs or by writing down the reinforcement position and measurements.

NG7.8 Modular roads

- 1) When excavating in modular roads, the modules must be lifted carefully and stored for re-use.
- 2) It is particularly important to ensure that bedding and jointing sands should meet the performance demands in areas subject to heavy vehicular traffic.

NG8 Footways, footpaths and cycle tracks

NG8.2 Sub-base and binder course reinstatement

Excavations adjacent to roads

The most heavily stressed area of a road is usually the inside wheel track adjacent to the road edge. Depending on ground conditions, it is often necessary to support the road edge by providing lateral restraint within the adjoining footway, footpath, cycle track or verge. The most common form of edge support is a section of unbound or CBGM base material. This construction will most commonly be encountered when the horizontal distance between the edge of the undertakers' excavation and the edge of the road surface is less than the expected depth of cover of the undertakers' apparatus.

NG8.3 Surface reinstatement

High duty and high amenity areas

- 1) In high duty footways the durability of the wearing surface is of prime importance, so simple cosmetic matching of materials may not be adequate. Specific grades of material such as Yorkstone modules or specific types of construction such as asphalt sand carpet (HRA 0/2 surf to BS EN 13108-4, also see PD 6691) may have been laid to give an acceptable performance under extreme conditions. In these cases, similar or equivalent grades of materials will need to be reinstated.
- 2) In high amenity footways, cosmetic matching of materials at the wearing surface may be of primary importance with durability of secondary importance.
- 3) When identifying a source of materials for reinstatement in high duty and high amenity areas, it is important that the material is suitable and readily available. Availability includes lead-in times for procurement and delivery of specific materials. Technical considerations may include potential for segregation, ease of compaction/installation and requirements for specialist training/accreditation.

Areas surfaced with bituminous materials

A wide range of surface treatments exists, commonly with less than 6 mm aggregate size. Where available, a similar surface finish will be reinstated. The surface course material may be reinstated using any of the allowed binder course or surface course materials, with a final surface treatment applied as soon as practicable following the laying of the permanent surface course.

Certain types of PMMA are sometimes used as a footway surfacing material for appearance and durability. Where an authority has a policy of using this material and reinstating with it, it is reasonable to expect the undertaker to comply with this. However, the cost of small quantities of PMMA is disproportionate to the size of the reinstatement and can result in significant wastage. Consequently, it is not unreasonable for an undertaker to wish to compile a programme of such works to achieve an efficient use of resources. Therefore, an authority should expect such work to be programmed so that sites requiring PMMA are batched to produce a package of work.

Areas constructed in concrete material

- 1) In general, reinstatements in a concrete footway, footpath or cycle track should match the existing surfacing as closely as is practicable.
- 2) Generally, the use of all flexible permanent reinstatements in overlaid concrete, PMMA, sand carpet (HRA 0/2 surf to BS EN 13108-4, also see PD 6691) or other derivative surfaces etc., has proven to be suitable in practice.

NG9 Verges and unmade ground

NG9.1 General

There are no technical restrictions within the SROH on plant suitability for excavation in verges and unmade ground. Excavation plant for micro trenching may be used (e.g. see S6.6). However, the reinstatement requirements are in accordance with S9.

NG10 Compaction requirements

NG10.1 Introduction

- 1) Research has shown that failure to operate and maintain compaction equipment in accordance with manufacturer's schedules and recommended practices is likely to result in inadequate compaction with serious implications for the short-term performance of individual structural layers and the long-term integrity of the entire reinstatement.
- 2) All compaction equipment covered by this Code must be frequently checked, adjusted and maintained as necessary in accordance with the manufacturer's recommendations to ensure that the correct operating frequency is maintained throughout each compaction operation.
- 3) All compaction equipment covered by this Code must be used in accordance with the manufacturer's recommended operating procedures.

NG10.2 Compaction of materials

Unbound granular and cohesive materials

For granular or cohesive materials, a vibrating roller may be unsuitable in small openings because of the restricted manoeuvrability of the large heavy rollers required to achieve adequate levels of compaction with an acceptable number of passes.

Compaction of backfill is a requirement to mitigate the risk of long term settlement. However, definitive measurements for density are often relatively complicated and not necessarily suitable for regular monitoring of works in reinstatements. These test methods include nuclear density testing (BS 1924-2).

There are standard tests available that may be used to measure performance (which can be correlated with adequate compaction/density). The main test methods are:

- 1) Lightweight deflectometer to BS 1924-2 for soils, unbound mixtures and HBMs.
- 2) California Bearing Ratio to BS 1377-4 for soils.

There are other tests methods available not covered by British Standards such as:

- 1) Ground penetrating radar
- 2) Surface wave propagation
- 3) Penetrometer

4) Clegg impact soil tester

In case of dispute about compacting backfill, the order of preference is definitive measurement and then standard tests (British Standards). The other test methods are limited in suitability dependent on their established correlation for the materials being tested.

Bituminous mixtures

- 1) With some combinations of compaction plant and certain types of bituminous mixtures, the following may result if compaction is continued as the material approaches its maximum density:
 - a) Migration of fines or binder to the surface.
 - b) Development of shear surfaces and/or crushing of aggregates.
- 2) Provided that the material has been laid and compacted within the appropriate temperature range, fewer passes will be required when any signs of distress become apparent.
- 3) Asphalt maximum density values, used in the calculation of air voids content, are specific to particular asphalt mixtures incorporating constituents from specific sources. Any variation in mix proportions or constituents requires the maximum density to be re-established.
- 4) Although consistent asphalt supply may allow an established maximum density for a particular mixture and source to be used for some time in routine situations, the definitive method to be used in the event of dispute will require the maximum density to be determined for the mixture actually used. The maximum density may be determined from bulk samples, if available, or from material obtained from additional core samples.
- 5) When taking cores near surface apparatus, S10.2.10 requires a minimum clearance of 100 mm to avoid damaging the apparatus or structure it is bedded on. However, it is possible that some surface apparatus may have wider than normal flanges and there may be instances where a greater clearance is required to avoid damage. If doubt exists, liaison with the owner of the apparatus should be undertaken in advance.
- 6) Where more than two cores are taken, one can be used for determination of maximum density value (BS EN 12697-5) and the remaining cores must be used for bulk density determination using the wax sealing method. This is the preferred method. Provision for the alternative sealing methods is included for when only a single core is available. This is done on the basis that removal of wax post-determination of air voids, and pre-determination of bulk density can be problematic.

As general guidance on air voids testing, it is important that care is taken to prevent damage to the specimen whilst sealing it. The seal must cover the specimen entirely, including voids that technically form part of its volume. It is equally important to prevent the sealing material from penetrating any internal voids or creating voids between the seal and the specimen or in seal folds. Trimming the bottom of a core

sample may be done to avoid testing voided material compacted against unbound material (see BS EN 12697-5 paragraph 7.3). However, this can only be done if the thickness of the layer (after trimming) is still within the layer thickness specification.

Testing asphalt surfacing which has been opened to traffic will not always give results representative of the as-built air voids condition. In particular, the process of coring may damage the sample. This requires specific consideration in terms of test procedure and results interpretation.

Modular surfacing materials

Depending on the size and type of paving module to be laid, and the extent of the area to be surfaced etc., the use of additional mechanical compaction may become necessary.

NG10.3 Equipment operation and restrictions

- 1) A single pass of any compaction plant is deemed to be completed when the foot, roll or plate of the compactor has impacted the entire surface area of the layer.
- 2) Where the excavation is more than 50 mm wider than the foot, roll or plate, two or more traverses of the compaction device will be required to ensure coverage of the entire surface and all will be deemed to constitute a single pass.
- 3) Compaction plant should be steered along a line offset from that steered on the previous pass so that alternate passes are run close in to each side wall of the excavation.
- 4) Small items of compaction plant will frequently be required and additional provisions must be considered for use in trenches within restricted areas. In general, lightweight vibrotampers and mechanical pole tampers are capable of achieving the same degree of compaction as the heavier items of plant specified in A8. However, small plant is usually not self-advancing and therefore more difficult to operate effectively.

Hand rammers

- 1) Hand rammers may be used for initial tamping of fine fill material or immediately adjacent to street furniture, reinstatement edges etc.
- 2) Full machine compaction complying with A8 will normally be applied immediately after the required thickness of material has been built-up. However, hand ramming alone may be necessary in small openings, narrow trenches, around access chamber covers, around standpipes and other isolated fixed features.

Percussive rammer

- 1) A percussive rammer is deemed to be a hand-held or pedestrian guided machine in which an electric, pneumatic or hydraulically operated reciprocating mechanism acts on a plate or 'foot'.

- 2) Percussive rammers may only be used to provide full machine compaction in restricted areas.

Vibrotamper

- 1) A vibrotamper is deemed to be a free-standing, pedestrian guided machine in which a reciprocating mechanism, driven by an integral engine or motor, acts on a spring system through which oscillations are set up in a base plate or 'foot'.
- 2) Vibrotampers may be operated at reduced speed, for the first pass only, with cohesive materials.
- 3) Vibrotampers are not preferred for any permanent surface course application or any other application involving a layer thickness of less than 50 mm.

Vibrating rollers

- 1) A vibrating roller is deemed to be a self-propelled pedestrian steered machine with a means of applying mechanical vibration to one or more rolls.
- 2) Vibrating rollers should be operated in the lowest available gear, except for the first pass which should be at maximum forward speed.
- 3) All compaction passes should be carried out with full vibration, except for the first pass which should be carried out without vibration to nip in the material adjacent to the reinstatement edges and to prevent uneven displacement of material within the remainder of the reinstatement area.
- 4) Vibrating rollers are the preferred method of compaction for all permanent surface courses.
- 5) The use of twin drum rollers is preferred to single drum for compacting bituminous mixtures and will improve the quality of the permanent surface course. However, single drum vibrating rollers are permitted, as detailed in A8.

Vibrating plate compactors

- 1) A vibrating plate compactor is deemed to be a pedestrian guided plate equipped with a source of vibration consisting of one or more rotating, eccentrically weighted shafts.
- 2) Vibrating plate compactors should be operated in the lowest available gear, except for the first pass which should be at maximum forward speed.

Other compaction equipment

Compaction plant not referenced in A8, including machine-mounted, modified and other alternative compaction equipment, may be permitted for compacting reinstatement materials in accordance with the following relevant requirements:

- 1) Machine-mounted compactors

A machine-mounted compactor is deemed to be any compaction equipment that is mounted as an attachment to the chassis or front or

rear booms of an excavator, tractor, skid-steer vehicle or other proprietary vehicle.

All machine-mounted compactors, whether integral to the vehicle design or on special attachments, should be operated in accordance with the recommendations of the compactor or attachment manufacturer, to the relevant compaction procedure required by A8. However, other operational variables should also be considered before operating such plant as follows:

a) Compactor downforce

The downforce will vary depending upon the weight of the vehicle chassis or compactor frame, and any additional force applied by hydraulic rams etc. However, changes in the configuration of any vehicle by adding or removing accessories etc, changes in the width of the vibrating foot, roll or plate etc, movement of any boom resulting in a significant change of loading geometry or outreach etc, attaching of the compactor to other vehicles of differing types or weights etc, can all result in a significant reduction of compactive performance that is seldom apparent. All operators should be aware of the potential reduction in compactive performance resulting from such changes in configuration.

b) Applied downforce

The mounting of compaction equipment to the front loader arms of an excavator, where the downforce is sensibly limited by the lifting of the front wheels, is preferred. All compactors mounted to the backhoe of an excavator should be fitted with a downforce-limiting device, correctly set, or with a simple indicating device allowing the amplitude to be estimated.

c) Compactor set-up

Where vibration frequency or amplitude, or any other parameter affecting the dynamic output of a compactor is expected to be adjusted on a routine basis, all parameters should be set in accordance with the manufacturer's recommendations unless specific testing meeting the requirements of NG1.6 (4) has shown other settings to be at least as effective.

2) Modified compaction equipment

Modified compaction equipment includes any proprietary vibrotamper, vibrating roller, vibrating plate compactor, percussive rammer or other compaction plant that has been adapted, converted, revised or otherwise changed from the original manufacturer's specification, resulting in a significant change to the original configuration, dimensions, operational weight or power output.

Modified compaction equipment is acceptable provided it is operated in accordance with compaction procedures meeting the following requirements:

a) The original manufacturer must provide written confirmation that the modified compaction equipment, operated in accordance with the

original compaction procedure, is capable of achieving the same degree of compaction as any other option permitted in A8, or

b) A revised compaction procedure is developed in accordance with the requirements of NG1.6. (4)

3) Alternative compaction equipment

Alternative compaction equipment includes all other compaction devices not specifically permitted within NG10.3. Alternative compaction equipment may be permitted, provided it is operated in accordance with compaction procedures developed in accordance with the requirements of NG1.6 (4).

NG11 Ancillary activities

NG11.1 Traffic signs, road markings, studs and verge markers

General

In the interests of safety, particularly for people with disabilities, all traffic signs, road markings, studs and verge markers removed during the course of the works should be replaced immediately following completion of works.

NG11.2 Street furniture and special features

Similarly, all street furniture, tactile paving and any other special features removed during the course of works should be replaced immediately following the completion of works.

NG11.3 Traffic sensors etc.

- 1) Examples of sensors include ice warning sensors, buried queue and traffic detectors, other electronic detectors and various data collection devices.
- 2) The replacement of some traffic sensors may require installation by specialist contractors.

NG11.4 Water-related matters

Water egress (street surface and utility apparatus)

- 1) If water issues from the street surface or an undertaker's apparatus, the authority must initiate an investigatory works procedure to determine the cause and source. Before starting investigatory work, the authority should contact any undertakers it believes may be responsible. Undertakers must co-operate with the authority in its investigation and may take trial holes and check apparatus for water leakage or surcharge through the apparatus, ducts and surround to the apparatus.
- 2) If, following the investigation, the authority has reasonable cause to believe that the leak is caused by or associated with the undertaker's apparatus, remedial measures must be agreed between the authority and the undertaker and carried out at the undertaker's cost. In the absence of agreement between the authority and the undertaker, liability for any damage must be determined in accordance with section 82 of the Act (Liability for any damage or loss caused).

NG11.5 Ironwork and apparatus

Access covers, frames and surround

The access surround is a critical feature because of the load transfer and point loads impacting on the fixed feature and as a potential point of weakness. It is therefore important that the surround is constructed to adequately withstand and transfer applied loads.

Compaction

Quality assurance for undertaker's custom and practice may include evidence of training records, method statement and quality plan.

NG12 Remedial works

NG12.1 General

Removal and replacement of the surfacing materials do not reset the guarantee period, only when an engineering investigation has been completed in accordance with S2.5 and an excavation is into the lower layers to rectify the cumulative settlement limit being exceeded, will the guarantee period be reset.

NGA2 Key to materials

NGA2.0 Introduction

For guidance on the terminology for asphalt mixtures refer to PD6691. If risks associated with hand-laying of asphalt with highly modified PMBs are not mitigated, they can lead to problems including failure at joints and surface fretting. If in doubt, seek advice from the material supplier to determine if the material is suitable for hand-lay. Guidance for assessing the skid resistance requirements can be found in CS 228 of the DMRB.


NGA2.1 Hot rolled asphalt (HRA) mixtures

- 1) HRA design mixtures give better resistance to deformation where queuing of heavy traffic is likely to occur, and may also be more economical to lay.
- 2) Type C mixtures use fine aggregate of a coarser grading than Type F mixtures – usually associated with the use of crushed rock fines. Such mixtures tend to be stiffer and are less well suited to the reinstatement of small openings.

Surface course mixtures

- 1) The advantage of using chipped HRA 30/10F 40/60 is that the mixture can be used in footways, footpaths, cycle tracks and the carriageway. The other HRA options are limited in application.
- 2) Special care should be taken when using high stone content HRA (HRA 55/14 and HRA 50/10) to comply with texture depths.
- 3) The use of HRA 30/10 F surf is especially convenient when the reinstatement extends into road types 3 or 4, as the same material can be used for the whole surface.
- 4) Figure NGA2.1 shows examples of good/bad rate of chippings.

Figure NGA2.1 Examples of Chippings rate

Low volume of chippings (potential risk of low skid resistance)	High volume of chippings and localised double chipping (risks include loss of chippings)
	

NGA2.2 Stone mastic asphalt (SMA) mixtures

General

- 1) SMA is a high stone content, gap graded material where the voids between aggregate particles are essentially filled with a bitumen-rich mortar.
- 2) SMAs are very rich in bitumen to the extent that measures have to be taken to prevent bitumen from draining out of the mix during transport. Most commonly bitumen drainage is prevented by adding polymer modifiers or cellulose fibre.
- 3) True SMA is intended to be virtually impermeable and has very good resistance to deformation because of its stone-to-stone structure. The level of texture depth achieved is largely a function of the material design, and is therefore likely to be more consistent than with HRA, where the application rate and the embedment of the surface applied coated chippings is critical.

Specification

- 1) There is a European Standard for SMAs, BS EN 13108-5 and, in the UK, a Published Document PD6691 "Guidance on the use of BS EN 13108 Bituminous mixtures – Material specifications".
- 2) There are also proprietary mixes that fit the generic description of an SMA.
- 3) Product Acceptance Scheme approved thin surface course systems may also comply with the HAUC requirements but there is no guarantee. Some Product Acceptance Scheme approved materials can have void contents in excess of that permitted in this Code. Purchasers

should make it clear to suppliers that the work has to comply with the air void specification.

Transport

- 1) As with all asphalt materials it is important that temperature loss is minimised during transport, handling and storage to allow effective placement and compaction. The high bitumen content of mixtures means that provided material temperatures remain elevated, then compaction is relatively easy.
- 2) Transporting should comply with the requirements of this Code and BS 594987.
- 3) To minimise the risk of segregation and temperature loss it is preferable to use the material direct from the delivery vehicle or hot box. Material should never be tipped on to adjacent surfaces for use sometime later.

Preparation

Preparation should comply with this Code and BS 594987. A polymer-modified bond coat is preferable when using SMA.

Laying

- 1) Placement of the SMA should be done in such a way as to avoid segregation of the mix. Where possible this is to be accomplished by careful use of a shovel. The use of a rake is to be avoided. Care must be taken with the use of some “hot boxes” as these can also cause segregation of mixes through the discharge augers.
- 2) Areas showing segregation should be removed as these are not acceptable at any time.
- 3) Where initial skid resistance of >40 SRV is required (all carriageway applications) or in areas where equestrian usage is likely, the surface should be gritted using a clean, dry, crushed quartzite, or a comparable very hard angular aggregate to a grading similar to that shown in Table NGA2.1. Alternatively, a 3 mm steel slag should be applied evenly to the surface during initial rolling, i.e., whilst the material is still warm. The rate of application should be set to provide about 80% surface coverage (approximately 1000 g/m²). Where the authority uses a lightly coated grit for the treatment of SMA, this may also be suitable.
- 4) After final rolling all surplus aggregate should be removed before the reinstatement is opened to traffic.
- 5) It is important that the application of grit should not reduce compliance with any texture depth requirement.

Table NGA2.1 Recommended aggregate grading for gritting SMA surfaces

BS test sieve:	% passing
6.3 mm	100
5.0 mm	95-100
3.35 mm	66-90
1.18 mm	0-20
0.060 mm	0-8
0.063 mm	0-1.5

Compaction

Compaction of the material is best carried out using a smooth wheeled roller. Vibration may be applied provided that this does not bring about excessive movement of the bitumen to the surface of the layer, i.e. “bleeding”. On narrow reinstatements compaction equipment in accordance with Table A8.1 may be used but care must be taken to ensure that there is no excessive loss of surface texture or bleeding.

NGA2.3 Asphalt concrete mixtures

Surface course mixtures

The use of higher binder content (B_{act}) in AC6 and AC10 mixtures than those detailed in PD 6691 Table B14 and B15 has been included to provide options for mixtures that have enhanced workability and reduce risks associated with air voids non-compliance. Care should be taken to avoid loss of texture or reduced resistance to rutting associated with an excessive increase in binder content. Liaison with the asphalt supply chain is recommended to optimise the benefits of adopting this type of material. It is the future intention to include specific provision for these mixtures in PD 6691.

Limited use of AC10 without agreement in footways, footpaths and cycle tracks has been included to enable efficient use of materials and it is not intended as a wholesale replacement for the preferred option of AC6 for this application.

NGA2.4 Cold-lay surfacing materials

PCSMs are allowed within equivalent materials in terms of performance. Engagement with the supply chain may be needed to understand equivalence of a product, for example a PCSM that is demonstrated as equivalent to HRA will be allowed within HRA.

NGA2.7 Structural layer thickness tolerances

Excessive layer thicknesses of HRA can lead to localised rutting likely to exceed the surface profile performance requirements set out in S2.2.

NGA2.9 Bituminous laying temperatures

To achieve acceptable air voids, most materials require greater compactive effort as the temperature approaches the lower limit. Additives are available that can be used to assist compaction at lower temperatures.

Table NGA2.2 Selection of asphalt surfacing reinstatement materials				
Existing	Road type 0&1	Road type 2	Road type 3&4	Footway, footpath and cycle track
If the existing surfacing is HRA or AC, HRA mixtures described on the right are acceptable. If the existing is TSCS or SMA the use of HRA is by agreement	HRA 30/14 F surf PMB des WTR2***	HRA 30/14 C surf 40/60 des*	HRA 30/10 F surf 40/60 rec	HRA 15/10F surf 100/150 rec
	HRA 30/14 C surf 40/60* des WTR2***	HRA 30/14 F surf 40/60 rec	HRA 30/14 C surf 40/60 des*	HRA 30/10 F surf 40/60 rec
	HRA 35/14 F surf PMB des WTR2***	HRA 30/14 F surf 40/60 des	HRA 30/14 F surf 40/60 rec	HRA 30/10 F surf 70/100 rec
	HRA 35/14 F surf 40/60 des WTR2***	HRA 35/14 F surf 40/60 des	HRA 30/14 F surf 40/60 des	HRA 30/10 F surf 100/150 rec
	-	HRA 35/14 F surf 40/60 rec	HRA 35/14 F surf 40/60 des	-
	-	-	HRA 55/10 F surf 40/60 des	-
	-	-	HRA 55/10 F surf 100/150 des	-
	-	-	HRA 55/14 F surf 40/60 des	-
If the existing surfacing is SMA/TSCS or AC, the SMA mixtures described on the right are acceptable	SMA 14 surf PMB WTR2***	SMA 14 surf PMB	SMA 14 surf PMB	SMA 6 surf 40/60
	SMA 14 surf 40/60 WTR2***	SMA 14 surf 40/60	SMA 14 surf 40/60	SMA 6 surf 70/100
	SMA 10 surf PMB WTR2***	SMA 14 surf 100/150	SMA 14 surf 100/150	SMA 6 surf 100/150
	SMA 10 surf 40/60 WTR2***	SMA 10 surf PMB	SMA 10 surf PMB	-
	SMA 6 surf PMB* WTR2***	SMA 10 surf 40/60	SMA 10 surf 40/60	-
	SMA 6 surf 40/60* des WTR2***	SMA 10 surf 100/150	SMA 10 surf 100/150	-
	-	SMA 6 surf PMB*	SMA 6 surf PMB*	-
	-	SMA 6 surf 40/60*	SMA 6 surf 40/60*	-
If the existing surfacing is AC the AC mixtures described on the right are acceptable	AC10 close surf 100/150 WTR2***	AC10 close surf 100/150	AC10 close surf 100/150	AC10 close surf 100/150**
	-	-	-	AC6 close surf 100/150
If the existing surfacing is SMA/TSCS	TSCS if required by the authority			
* Only by agreement				
** if trench is in carriageway and extends to the footway (maximum continuous 10 linear m or 4 m ² or by agreement)				
*** WTR1 is permitted for road type 1 for locations outside heavily stressed areas				

NGA2.13 Selection process for hot lay flexible materials

Table NGA2.2 summarises asphalt surface material reinstatement options. Reference should be made to A2 for details, specific requirements and any restrictions.

NGA8 Compaction requirements

NGA8.3 Bituminous mixtures

Table NGA8.1 provides guidance for compaction procedures that may be capable of achieving the specified air voids values.

Table NGA8.1 Compaction requirements for bituminous mixtures				
Compaction plant and weight category	Bituminous mixtures			
	Minimum passes/lift for compacted lift thickness up to			
	40 mm	60 mm	80 mm	100 mm
Vibrotamper 50 kg minimum	5#	7#	NR	NR
Vibrating roller Single drum				
600-1000 kg/m	10	12	NR	NR
1000-2000 kg/m	6	10	NR	NR
2000-3500 kg/m	5	7	8	NR
Over 3500 kg/m	4	6	7	NR
Vibrating roller Twin drum				
600-1000 kg/m	5	7	NR	NR
1000-2000 kg/m	4	5	6	8
Over 2000 kg/m	3	4	4	6
Vibrating plate				
1400-1800 kg/m ²	6	NR	NR	NR
Over 1800 kg/m ²	3	6	6	8
All above plant	For Maximum and Minimum compacted lift thickness Table A2.5			
Alternative compaction plant for restricted areas				
Vibrotamper 25 kg minimum	Minimum of 6 compaction passes			
Percussive Rammer 10 kg minimum	Maximum of 75 mm compacted lift thickness			
Notes:				
1) NR = Not Recommended				
2) # = Vibrotamper not recommended on permanent surface course of trenches > 500 mm width				
3) Twin drum vibrating rollers are preferred for compaction of bituminous mixtures				
4) Single drum vibrating rollers are vibrating rollers providing vibration on only one drum				
5) Twin drum vibrating rollers are vibrating rollers providing vibration on two separate drums				
6) Mechanical pole tampers should be considered for compaction around iron work.				

NGA9 Alternative reinstatement materials and technologies

NGA9.1 Introduction

Promoters of alternative reinstatement materials (ARMs) and alternative technologies (ATs) are likely to be undertakers, contractors or manufacturers of proprietary products, plant or equipment. However, the benefits of ARMs and ATs extend to a wide range of stakeholders with positive impacts on safety, congestion, the environment, the asset and the wider benefits of efficient working.

The SROH also includes provision for Product Acceptance Schemes. Where appropriate, ARMs and ATs should be developed with a view to being covered under a Product Acceptance Schemes or included within a subsequent revision of the SROH. For guidance, the process for obtaining a Product Acceptance Scheme certificate should apply the same level of safety, practical and technical rigour as is applied when assessing ARMs and ATs.

Treated materials for fill (TMF) covers a range of materials that are treated before use. The purpose of the treatment is improvement, not necessarily stabilisation. Improvement includes treating wet or cohesive materials to enable placement and compaction. The performance characteristics of TMF are lower than SMR and are based on their mechanical performance post immersion in water (soaking). This means the performance of the TMF (SMF Class B to D) is typically dictated by the nature of the compacted soil and aggregate mix. SMF Class A could either be a granular material similar to the above, or a predominately fine-grained material including clay that has been stabilised. Particular care and attention is required to ensure it is a stabilised product (see description under SMR).

TMF may be trialled for use as surround to apparatus, backfill or sub-base. If used as a surround to apparatus, particular care is required to avoid damage during placement and compaction.

Non flowable structural material for reinstatement (NFSMR) is an SMR designed to provide a stabilised product. Stabilisation is a process that obtains a homogenous mixture of soil or graded granular material using treating agents and, optionally, water. When properly compacted, it significantly changes the characteristics of the material in a way that renders it stable, particularly with respect to the action of water and frost.

Flowable structural material for reinstatement (FSMR) is an SMR designed to provide a flowable product that hardens during curing. It does not require compaction.

Structural material for reinstatement (SMR) may be trialled for use as surround to apparatus, backfill, sub-base, base or binder (subject to road category). If used as a surround to apparatus, particular care is required to avoid any damage during placement and compaction.

HBM's have an extensive track record in highways in the UK going back to civils works in the 1960s and include a wide range of different constituents and categories of performance. A10.2 HBMs are most akin to NFSMR; including an upper limit on strength. However, standardised requirements; including constituents, test methods, testing regimes, mixture and production control requirements apply to HBM. These requirements mean that A10.2 HBMs do not require an A9 trial and are only typically achieved with static production facilities (see A10.2).

The mixture test requirements for SMR and TMF are not suitable for all material types and applications. An example of non-suitability is bituminous based mixtures (asphalt) that are classified based on a different suite of testing than that included for SMR and TMF. Reference should be made to the appropriate British Standards (BS) or European (BS EN), and this Code for materials proposed as ARMs that do not fall under the SMR and TMF categories.

Using the example of an ARM that is a bituminous based mixture, it is anticipated that reference would be made to standards including those for aggregate (BS EN 13043), bitumen (BS EN 12591 or BS EN 14023 for polymer modified bitumen), mixture (BS EN 13108), UK specific guidance (e.g. PD6691) and British Standard specifications (e.g. BS 594987).

For these materials a higher level of technical input and expertise is anticipated in the development and support of ARMs through the A9 process.

NGA9.2 General requirements for ARMs and ATs

Mix formulations are based on the constituents (including soil/aggregate, binder and water), mix proportions (including grading or pulverisation limits) and production tolerances. The mix formulation typically requires adjustment during works for variables such as water and binder addition. This is common to a wide range of construction materials and is required to accommodate differences in workability arising from variations in internal factors (e.g. variation in feedstock) and external factors (e.g. environment and temperature). These adjustments are requirements of production control to achieve the end product performance requirements of A9. Adjustments that may be considered significant and outside of this mix formulation adjustment include changing the type of binder(s) from that used in the mix design, and adjustment to binder above or below the limits established during the design testing.

There are some situations where continuity of drainage is a consideration when selecting reinstatement materials, especially backfill and sub-base. An example of this may include steep areas of road with water flowing in the foundation layers. A reinstatement cutting across this pathway, could in theory create a dam resulting in water washing materials away or creating a seepage line. SMRs have relatively low permeability owing to their physical nature. Therefore, recommendations to consider use of pea gravel in a geotextile rap are included in A9. For context, unbound mixtures (for example GSB1) are not necessarily free draining so the same consideration may be applied to their use.

SMRs have end product requirements that include strength class. They also have a performance requirement to be suitable for overlay with subsequent layers in the reinstatement. Depending on the nature and scenario where an SMR is used, it may perform well enough to be overlaid before the development of the minimum required strength class (see Table A9.1). If required, this potential may be established during the A9 approval process. This can be defined by the immediate bearing index for NFSMR which has mechanical interlock (see A10). Alternatively, this can be defined by a minimum strength class and/or period of time. Both should be linked to in situ curing of the material. It is important that the trials for this establish that overlay before full strength gain does not adversely damage the material versus its end product requirements (see Table A9.1).

NGA9.4 Treated materials for fills (TMFs)

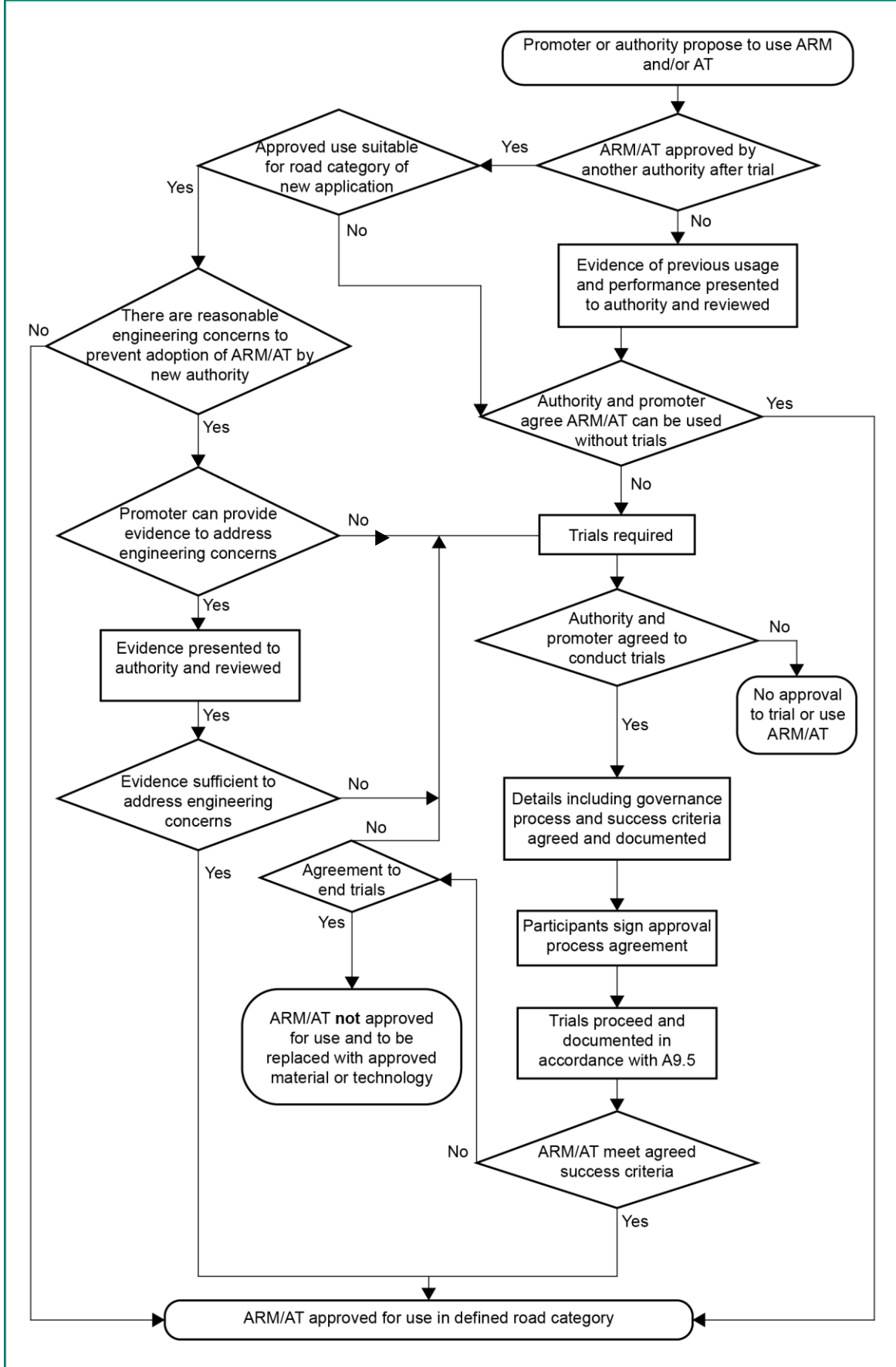
The term “treated materials for fills (TMFs)” has been included in this version of the Code to substitute the term “stabilised materials for fill (SMFs)” from previous versions. The term “treated” includes more types of materials, including stabilised ones. Therefore, this amendment is aimed at providing more flexibility to use innovative materials.

NGA9.5 Outline scheme for the approval trials

Introduction

Figure NGA9.1 shows a flow chart describing the approval procedure for ARMs and ATs.

Figure NGA9.1 Approval procedure for trials



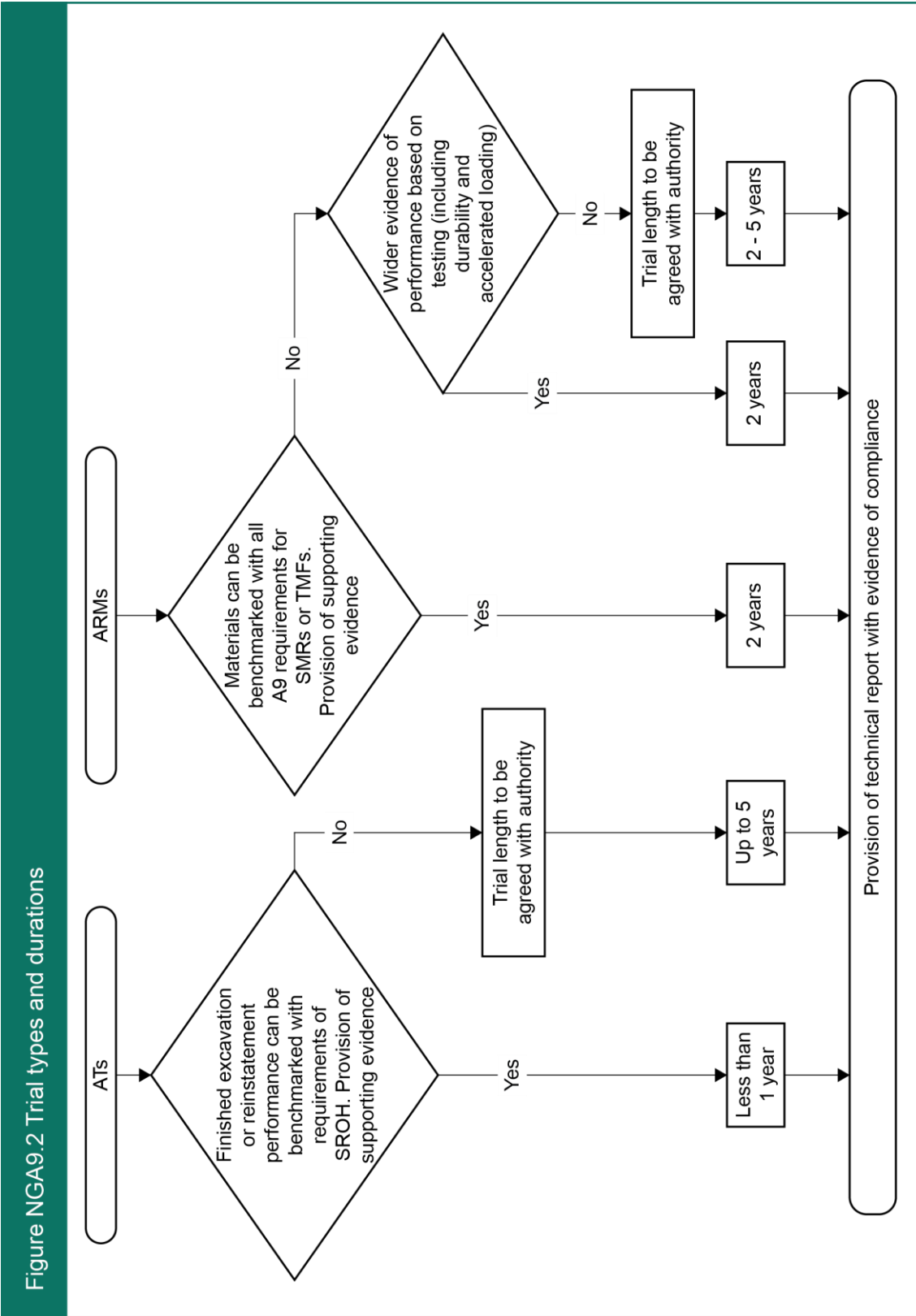
Engineering concerns include factors that indicate there is a reasonable challenge to the assumption of successfully transferring an ARM or AT into a new authority area. The starting point for this is that the ARM or AT has been approved, that evidence from the trials demonstrate compliance with the requirements of A9 and that the ARM or AT is suitable to be used in a new authority area. Engineering concerns may mean additional trials or validation data sets are required to address the points raised.

Examples of reasonable engineering concerns include regional variation in feedstock that is outside of a mix design process (e.g. proportions of high plasticity clay or chalk), nature of the constituents (e.g. high organic content in peat or alluvial clays), rounded/sub round gravel content etc), and condition of the constituents (e.g. areas with high water tables). The above reasonable engineering concerns are not barriers to the use of ARMs or ATs, but they are specific conditions which, if not previously encountered, could result in different outcomes i.e. they are technical risks. Therefore, it is reasonable to challenge the requirement for additional trials for validation purposes, or the applicability to a specific area. Further, it is important to differentiate between global engineering concerns for an area and potential local concern within an area which may restrict widespread application.

General requirements, special considerations and duties of parties in the approval trial

General requirements for approval trial

Figure NGA9.2 shows how to select the appropriate trial duration depending on the type of innovation proposed (technology or material) and the type of material and the supporting evidence provided.



Suggested information for inclusion in approval trial agreement

Example of information to be provided:

Definition of the trial, to include details (as required) of:

- Material;
- Method;
- Process;
- All participants
- Track record of use or similar

A) Type and location of the trial sites (if required):

Number of trial sites required to comply with the approval process. Are they to be routine utility excavation or excavations for trial purposes?

Road category or footway/footpath/cycle track classification.

B) Positioning of trial site

Position of reinstatement within the road e.g. within n/s wheel track

Either:

C) Material details and material preparation

Mix design, binder details, additives, dependencies related to on site conditions.

Details of batching, mixing, transport and placement procedures.

Weather protection, etc.

And/or:

D) Method and/or process details

Details of method and/or process to be adopted, reference to relevant plant and equipment, etc.

E) Quality Assurance and control process

The details of site testing and assessment carried out to confirm suitability and compliance.

Details of retrospective and ongoing testing and inspection criteria.

Types of samples and sampling frequencies for both the trial and for ongoing QA.

Contact details for accredited laboratories used to carry out development and assessment testing.

NGA10 Additional standard materials

NGA10.0 General

The SROH 3rd Edition referred to the MCHW for the use of HBMs outside the requirement for the A9 trial approval process. The MCHW does not give specific provision for HBMs within street works so appendix A10 has been created to directly call up the requirements from BS EN 14227 for this purpose.

Requirements contained in A10 for HBMs aim to be equivalent to that for bituminous and concrete products. This includes a quality control, inspection and testing. Hand mixed and other forms of production that do not meet these requirements can be progressed via the pre-existing A9 approval trials.

NGA10.2 Hydraulically bound materials (HBMs)

Laboratory mixture design procedure for HBM

The strength designation for HBMs is the R_c strength class in (MPa). In the example “C3/4”:

- 1) the first number after C is the R_c (in MPa) at 28 days for cylinders with a slenderness ratio of 2. In this example, it is 3 MPa.
- 2) the second number is the R_c for cylinders with a slenderness ratio of 1 and cubes. In this example, it is 4 MPa.
- 3) the slenderness ratio is defined as the height to diameter ratio of a cylindrical specimen.

The maximum strength class for A10 HBMs of C9/12 is included to mitigate potential issues related to reflective cracking through thin asphalt overlays.

In case of defective works or conflict, the in-situ wet density may be used to verify the strength of the HBM.

For testing freshly compacted material, nuclear density testing to BS 1924-2 using a calibrated nuclear density gauge is the definitive method. The gauge must be used in the direct transmission mode of operation. The source rod must be lowered to within 25 mm of the bottom surface of the layer.

Each test at the location must consist of at least 3 measurements at 120 degrees to each other using the same source rod hole and the density taken as the average of the higher 2 results. Readings must be taken within two hours of completing compaction.

The in-situ density of HBM must be taken as the average of the wet density at five positions determined by the authority, and must achieve no less than 95% of the nominal wet density at the design strength specified.

For laboratory testing purposes, HBM samples can be cast in cubes or cylinders. Where agreed, coring may be used to obtain cylindrical specimens. However, low strength HBMs (i.e. anything less than strength class C6/8) or mixtures using slow hydraulic binders, standard unconfined compressive strength tests tend not to give reliable results.

In-situ testing can also be used to determine stiffness (e.g. via Light Weight Deflectometer) and density (e.g. via Nuclear Density Meter). Tests for HBMs are defined in the various parts of BS EN 13286. Test methods for density of HBM are also detailed in BS 1924-2.

NGA12 Reinstatement of modular surfaces

NGA12.1 General

- 1) For the purposes of this Code, modules where one side of the module is generally greater than 305 mm, are assumed not to rely on infill sand between the vertical faces of the modules. Instead, gaps between these modules are normally filled, or pointed, with a cement:sand mortar.
- 2) Modules with sides generally up to and including 305 mm rely on jointing sand between the vertical faces of the modules, normally achieved through vibration methods with jointing sand subsequently brushed into joints upon completion. It is essential that the jointing sand is kiln dried and free flowing. Sharp sand or building sand are not normally deemed to meet these requirements, although in some situations the use of sharp sand has been found to provide increased durability.
- 3) There may be a need to revisit sites to top up jointing sand following subsequent trafficking.
- 4) There may be a need to apply a sealant on sites subject to mechanical/vacuum sweeping.

NGA12.2 Examples of cement or concrete infills

Figures NGA12.1 to NGA12.3 provide guidance on acceptable treatment of cement or concrete infills between the nearest practical module and the immediately adjacent fixed feature or boundary feature, as described in A12. Figures NGA12.1 and NGA12.2 show infills in modules of one side greater than 305 mm, whilst Figure NGA12.3 shows infills in modules with sides up to and including 305 mm.

NGA12.3 Examples of reinstatement of modular patterns

- 1) Priorities when selecting a suitable source or supplier are aspects of safety (e.g. skid/slip resistance), durability and aesthetics, in that preferred order. The criteria stated in A12.3.2 are prioritised primarily for aesthetic purposes and assume safety and durability have been satisfied.
- 2) Figures NGA12.4 to NGA12.6 provide guidance as to acceptable treatment of modular patterns in localised reinstatements immediately adjacent to fixed features or boundary features. The principle of an acceptable loss of local pattern is indicated, together with the use of

larger cut and shaped pavers, both leading to an improved aesthetic and structural arrangement of the modules within the reinstatement.

Figure NGA12.1 Extension of infill concrete - modules over 305 mm

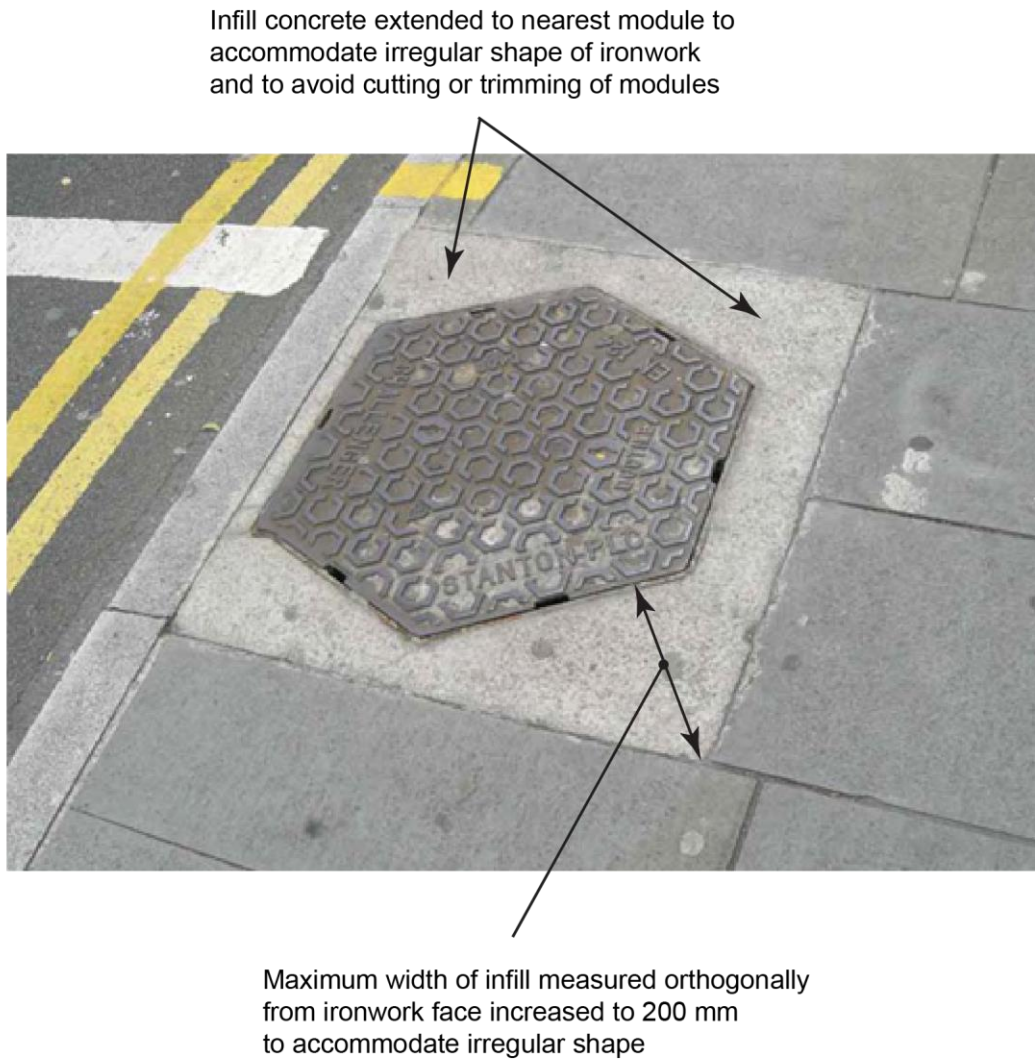
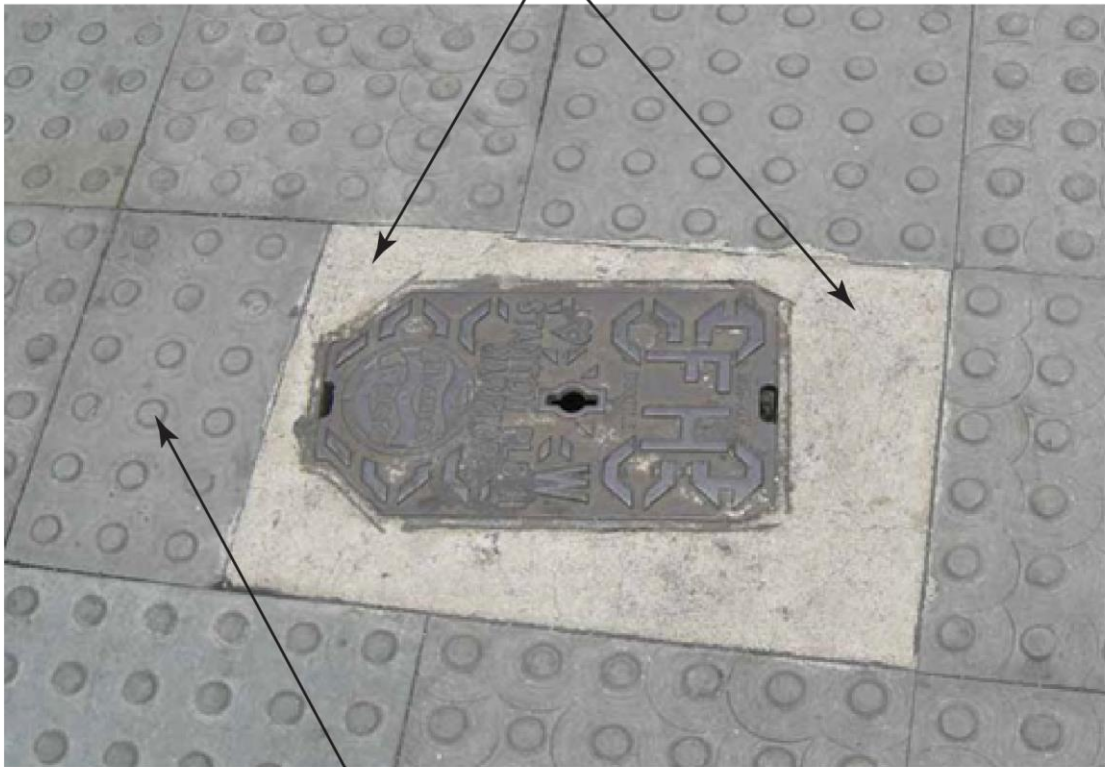


Figure NGA12.2 Extension of infill concrete - modules over 305 mm

Infill concrete extended to nearest module to accommodate irregular shape of ironwork and to avoid cutting or trimming modules



Using varying width infill limits cutting or trimming of modules

Figure NGA12.3 Extension of infill concrete – modules up to 305 mm

Using varying width concrete infill
avoids need to cut or trim modules



Maximum width of infill is the
width of a module plus 25 mm

Infill concrete extended to
nearest complete module

Figure NGA12.4 Acceptable loss of module pattern – modules up to 305 mm

Use of cut half blocks (100 mm x 100 mm) minimises apparent loss of module pattern (herringbone in this example)



Use of larger blocks here creates acceptable loss of module pattern. This is preferred over using small angular blocks to maintain the pattern.

Figure NGA12.5 Acceptable loss of module pattern – modules up to 305 mm

Use of larger cut blocks here creates acceptable loss of module pattern (herringbone in this example). This is preferred over using small angular blocks to maintain the pattern.



Use of larger cut blocks here leads to preferable arrangement of block pavers at the corners

Figure NGA12.6 Acceptable loss of module pattern – modules up to 305 mm

Use of cut half blocks (100 mm x 100 mm) minimises apparent loss of module pattern (herringbone in this example)



Use of larger cut blocks here creates acceptable loss of module pattern. This is preferred over using small angular blocks to maintain the pattern.