



Driver & Vehicle
Standards
Agency

Individual Vehicle Approval (IVA) Inspection Manual

Heavy goods vehicles (N2 and N3)

May 2026



Keeping **Britain** moving, **safely** and **sustainably**



Driver and Vehicle Standards Agency ©Crown Copyright 2026.

You may re-use this information (not including logos) free of charge in any format or medium, under the terms of the Open Government Licence v3.0.

To view this licence, visit www.nationalarchives.gov.uk/doc/open-government-licence/ or write to the Information Policy Team, The National Archives, Kew, London TW9 4DU, or email: psi@nationalarchives.gsi.gov.uk

Any enquiries regarding this publication should be sent to us at enquiries@dvsa.gov.uk

This publication is also available on the GOV.UK website at

<https://www.gov.uk/government/publications/iva-inspection-manual-vehicle-categories-n2-and-n3-hgvs>

Contents Page

Version Control & Release Notes

Time bound concessions to required standards

Foreword

Age-Related IVA

01 Noise

02 Emissions

03A Fuel Tanks

03B Rear Protective Devices (Under-Run)

04 Rear Registration Plate Space

05 Steering Effort

06 Door Latches and Hinges

07 Audible Warning

08 Indirect Vision

09 Braking

10 Electromagnetic Compatibility

13 Anti – Theft / Immobiliser / Alarm

15 Seat Strength

17 Speedometer and Reverse Gear

18 Statutory Plates

19 Seat Belt Anchorages

20 Installation of Lights

21 Retro Reflectors

**22 End-outline, Position (Side), Stop, Side Marker & Daytime
Running Lamps**

23 Direction Indicators

24 Rear Registration Lamps

25 Headlamps

26 Front Fog Lamps

27 Towing Hooks

28 Rear Fog Lamps

29 Reversing Lamps

31 Seat Belts

33 Identification of Controls

34 Defrost / Demist

35 Wash / Wipe

36 Heating Systems

42 Lateral Protection

43 Spray Suppression

45 Safety Glass

46 Tyres

47 Speed Limiter

48A Masses and Dimensions

48B Masses and Dimensions: STGO

49 Exterior Projections of Cabs

50 Couplings

57 Front Under-Run

62 Hydrogen Powered Motor Vehicles

65 Advanced Emergency Braking Systems (AEBS)

66 Lane Departure Warning Systems (LDWS)

69 Electrical Safety

General Construction

Glossary of Terms

This page intentionally left blank

Version Control & Release Notes

Section Number	Section Title	Revision Date	Revision Number
	Foreword	11/05/2026	12
	Age-Related IVA	10/04/2018	6
01	Noise	28/11/2025	7
02	Emissions	11/05/2026	9
03A	Fuel Tanks	20/10/2023	9
03B	Rear Protective Devices (Under-Run)	28/11/2025	7
04	Rear Registration Plate Space	20/10/2023	7
05	Steering Effort	29/10/2014	3
06	Door Latches and Hinges	01/09/2015	6
07	Audible Warning	29/10/2012	2
08	Indirect Vision	20/10/2023	10
09	Braking	10/04/2018	4
10	Electromagnetic Compatibility	01/09/2015	4
13	Anti – Theft / Immobiliser / Alarm	01/09/2020	6
15	Seat Strength	20/10/2023	4
17	Speedometer and Reverse Gear	01/09/2020	7
18	Statutory Plates	11/05/2026	14
19	Seat Belt Anchorages	03/02/2014	5
20	Installation of Lights	11/05/2026	10
21	Retro Reflectors	11/05/2026	13
22	End-outline, Position (Side), Stop, Side Marker & Daytime Running Lamps	11/05/2026	11
23	Direction Indicators	20/10/2023	7
24	Rear Registration Lamps	01/09/2020	4
25	Headlamps	11/05/2026	10

Section Number	Section Title	Revision Date	Revision Number
26	Front Fog Lamps	01/09/2020	3
27	Towing Hooks	01/09/2015	4
28	Rear Fog Lamps	11/05/2026	8
29	Reversing Lamps	11/05/2026	6
31	Seat Belts	10/04/2018	8
33	Identification of Controls	31/01/2011	3
34	Defrost / Demist	16/08/2010	2
35	Wash / Wipe	31/01/2011	3
36	Heating Systems	28/11/2025	6
42	Lateral Protection	28/11/2025	11
43	Spray Suppression	20/10/2023	8
45	Safety Glass	10/04/2018	6
46	Tyres	11/05/2026	7
47	Speed Limiter	10/04/2018	6
48A	Masses and Dimensions	28/11/2025	12
48B	Masses and Dimensions STGO	01/09/2015	2
49	Exterior Projections of Cabs	10/04/2018	7
50	Couplings	28/11/2025	8
57	Front Under-Run	01/09/2015	6
62	Hydrogen Powered Motor Vehicles	01/09/2020	3
65	Advanced emergency braking systems	01/07/2018	1
66	Lane departure warning system	11/05/2026	2
69	Electrical Safety	28/11/2025	4
	General Construction	31/01/2011	2
	Glossary of Terms	28/11/2025	8

Release Notes

Version 14.1

Section Number	Section Title	MOI change	Required Standards	TSE Incorporated	Details
-	Foreword	-	-	-	Updated wording at obligatory approval certificates paragraph. Added acceptable UNECE Regulations to Item 13, Summarised table of Directive Requirements. Item 69 title corrected.
02	Emissions	Y	N	Yes	Added reference to Note 1 from RS 1 & revised Note 1 to include alternative compliance (TSE IVA N2N3 002 002).
18	Statutory Plates	Y	N	-	MOI opening paragraph wording revised.
20	Installation of Lights	N	N	-	Improved format of Figures 4 & 4a. Added Figure 6.
21	Retro Reflectors	N	N	-	Clarified positional allowance for Red rearmost side retro-reflectors in Table 1 (Colour).
22	End-outline, Position (Side), Stop, Side Marker & Daytime Running Lamps	Y	N	Yes	New Note 8 referenced from RS21 header. Previous Note 8 renumbered to Note 9, reformatted, and referenced from RS25 (TSE IVA N2N3 022 011).
25	Headlamps	N	N	-	Maximum height updated to include N3G.
28	Rear Fog Lamps	Y	N	-	Note 4 revised & added reference from Table 1, 'Min height'.
29	Reversing Lamps	Y	Y	-	MOI wording, Note 1 wording, header to RS7, & RS 7 revised. New Notes 2 & 3. Permitted speed at RS8 revised. RS9 added. Addition of manoeuvring lamps to Table 1.
46	Tyres	N	N	-	Rows 90 – 100 km/h added to Table 4.

Section Number	Section Title	MOI change	Required Standards	TSE Incorporated	Details
66	Lane departure warning system	N	N	-	Correction of RS number.

Version 14

Section Number	Section Title	MOI change	Required Standards	TSE Incorporated	Details
-	Foreword	-	-	Yes	Regulation 13H removed from 09 Braking, Summarised Directive Requirements. 'Summarised List of Requirements' table, 05 Steering Effort: Added UNECE Regulations reference to new table footnote in respect of steer-by-wire systems (TSE N2N3 FWD 001). 'Run Lock' paragraph revised.
01	Noise	Y	N	Yes	Note 1 revised. Revised heading to RS8 & added reference to Note 1 (TSE N2N3 001 001).
02	Emissions	Y	N	No	Added reference to Age-related section to MoI. Table 1 formatted.
03B	Rear Protective Devices (Under-Run)	Y	N	Yes	Amend footnote to vehicle exemptions table in MoI (TSE IVA N2N3 03B 002). Move 'Rigid car transporter vehicles' out of STGO Exemptions in Table at MoI.
18	Statutory Plates	Y	N	No	Opening paragraph at MoI revised to include details of plate and inscription attachment.
20	Installation of Lights	Y	-	Yes	Revise MOI to clarify consideration of tyres (TSE IVA N2N3 020 009). Revise 'Two or more lamps' paragraph in MOI & add Figure 4b (TSE IVA N2N3 020 010).
21	Retro Reflectors	Y	N	Yes	Paragraph added to MoI to clarify 'if built into a lamp cluster'. Footnote added to Table 1 to include details regarding optional

Section Number	Section Title	MOI change	Required Standards	TSE Incorporated	Details
					reflectors (TSE IVA N2N3 021 004). Figure 7 revised. Improved format of diagrams at Part III.
22	End-outline, Position (Side), Stop, Side Marker & Daytime Running Lamps	Y	N	Yes	Clarify height requirements in Table 1 for End outline marker lamps (TSE IVA N2N3 022 008). Add footnote to Table 1 detailing symmetrical requirements for Position and End Outline Marker Lamps (TSE N2N3 020 013). Improved format of Table 1. Clarification of requirements for optional side marker lamps in Note 3. SM2 added as applicable marking for optional side marker lamps in Table 1.
28	Rear Fog Lamps	Y	N	Yes	Revise Table 1 Max. Height column and add new Note 5 (TSE IVA N2N3 028 001).
29	Reversing Lamps	N	Y	Yes	Revise RS6 (TSE IVA N2N3 029-003). Table 1 reformatted.
36	Heating Systems	N	N	No	RS8 format corrected.
42	Lateral Protection	Y	Y	Yes	Paragraph added to Mol relating to exempted vehicle requirements (TSE N2N3 042 008). Note 3 format revised. Reference to Note 6 corrected & added reference to new Note 12 from RS9. Added reference to new Note 12 from RS13. Added reference to new Note 12 from RS17. (TSE IVA N2N3 042 006). Heading for RS13-18 revised. Figure 6 added.
46	Tyres	Y	N	No	Added Note 7 referenced from RS7.
48A	Masses and Dimensions	N	N	No	Added Note to Annex 1. Annex 1, Item (c): Rear-view mirrors renamed to 'Devices for Indirect Vision'. Correction of item numbers in table at Annex 2.
50	Couplings	Y	N	Yes	Note 3 revised; includes train weight applicable to a 50mm ball coupling (TSE IVA N2N3 050 003).

Section Number	Section Title	MOI change	Required Standards	TSE Incorporated	Details
69	Electrical Safety	Y	N	No	Paragraph added to Mol to clarify acceptance of unmodified mass-produced vehicles (TSE IVA N2N3 069 002).
-	Glossary of Terms	-	-	No	Added 'Devices for Indirect Vision'.

Version 13

Section Number	Section Title	MOI change	Required Standards	TSE Incorporated	Details
01	Noise	Y	N	No	Revise application: Electric Vehicles – RS7 only
03a	Fuel Tanks	Y	Y	No	Removal of outdated directives in Mol. Addition of RS13 and Note 3 to clarify Hydrogen requirements
04	Rear Registration Plate Space	Y	Y	Yes	New Note 3 referenced from RS4 (TSE IVA N2N3 04 001).
08	Indirect Vision	N	Y	Yes	New RS 8 added, old RS8 renumbered (TSE IVA N2N3 048 005) Table 2 notes referenced, N2/N3 (post 26/01/2007). Figure 1 & 2 revision including correction of locations for Class V close proximity mirrors
15	Seat Strength	N	N	No	Corrected wording in Note 2
20	Installation of Lights	N	Y	Yes	Revise RS1 to Include allowance of red light from front (TSE IVA N2N3 020 008). Revise Fig 3 to define zone area, and insertion of Figure 3a diagram and associated text to clarify 'view to the front and rear' (TSE IVA N2N3 020 008). Revise

Section Number	Section Title	MOI change	Required Standards	TSE Incorporated	Details
					RS6 to clarify 'fixed open position' & create Note 2 referenced from RS6. (TSE IVA N2N3 020 006). Revision of Figure 4 to align with other IVA manuals. (TSE IVA N2N3 020 007)
21	Retro Reflectors	N	Y	No	Amend Table 1 Max. Height Side Retro Reflectors. Add minimum height requirement to Figures 4, 6 & 8 referenced from RS11
22	End-outline, Position (Side), Stop, Side Marker & Daytime Running Lamps	N	N	Yes	New Note 7 and renumbering of existing Notes. (TSE IVA N2 N3 022 008)
23	Direction Indicators	Y	N	No	Revision of MOI paragraph 4; including a link to Section 25 Note 4(b)
25	Headlamps	Y	N	No	Revision of Note 4(b) additional dipped beam headlamp height requirements for special purpose vehicles
43	Spray Suppression	Y	N	Yes	Skip loaders added to list of exempt refuse vehicles (TSE IVA N2N3 043 003)
46	Tyres	Y	N	Yes	Revise Annex 1 to include requirements for re-treaded tyres TSE IVA N2N3 046 001
48A	Masses and Dimensions	Y	Y	Yes	Update to RS1 table footnote to reference equipment. New Note 5 referenced from RS1 (TSE N2 N3 048-007). Revise Annex 1 'access ramps' paragraph (TSE IVA N2N3 48A 008). Added more items to length and width exemptions in Annex 1 columns A and B. Revise Table at Annex 2: Columns 4-8; new Notes 1 and 2; add 'Zero emission vehicles'.
69	Electrical Safety	Y	Y	Yes	Section renamed to match RV(A)R 2020, application clarified, reference to glossary added to MOI. Removal of RS3 & re-numbering of remaining RS. TSE IVA N2N3 069 001
-	Glossary of Terms	-	-	-	Definition of Hybrid Electric Vehicle & Zero emission vehicle added

Time bound concessions to required standards

Section Number	Section Title	End Date	Details	Notes

Foreword

This Manual is a detailed guide on the examination of vehicles submitted to an authorised site under the Individual Vehicle Approval (IVA) scheme.

It is produced for the examiners who carry out the examinations and for vehicle presenters and other interested parties who wish to familiarise themselves with the technical requirements and examination procedures.

Application

The IVA scheme is one of three routes for a road vehicle to gain approval and thereby obtain licensing and registration in the UK.

The IVA route is open to vehicles falling under the following categories:

M1, M2, M3,
N1, N2, N3
O1, O2, O3, O4

This manual covers solely the IVA technical requirements for vehicles of the following categories:

Motor vehicles with at least four wheels used for the carriage of goods.

N2: Vehicles used for the carriage of goods and having a maximum mass exceeding 3.5 tonnes but not exceeding 12 tonnes.

N3: Vehicles used for the carriage of goods and having a maximum mass exceeding 12 tonnes.

For information on other vehicle categories, the following DVSA IVA inspection manuals should be consulted.

- The Passenger Vehicle IVA Inspection Manual for vehicle category M1
- The Light Goods Vehicle IVA Inspection Manual for vehicle category N1
- The Bus and Coach IVA Inspection Manual for vehicle categories M2 and M3
- The Trailer IVA Inspection Manual for categories O1, O2, O3 and O4

Obligatory Individual Approval Certificates

The Individual Vehicle Approval (IVA) scheme is one of the approval routes through which a road vehicle can obtain approval for legal entry into service in Great Britain. The other available routes are GB Type Approval and the GB National Small Series Type Approval (GB NSSTA) scheme. In addition, UK(NI) Type Approval and UK(NI) National Small Series Type Approval (UK(NI) NSSTA) may apply, depending on the circumstances. Refer to the Road Vehicles (Approval) Regulations 2020 (SI 2020 No. 818), as amended.

Information on vehicle type approval routes is also available on the Vehicle Certification Agency website: <https://www.vehicle-certification-agency.gov.uk/vehicle-type-approval/>

Approval Process

With the IVA examination, the onus is on the applicant to provide evidence of compliance. This can, for example, be in the form of manufacturer's markings on the vehicle or component, an EC certificate of conformity for an incomplete or base vehicle and details of the systems approved, documentary evidence from the competent authority in the country of origin or the manufacturer, submission of a test report from an accredited Technical Service or a combination of such elements, and it may also include a degree of visual examination and practical tests. Applicants may be required to dismantle certain parts of the vehicle to allow DVSA examiners to carry out a full and meaningful examination.

Applications and supportive documentation will be assessed prior to the issue of an appointment. Examination of the vehicle will include verification checks to confirm as far as possible compliance with the required standards.

A vehicle built to a later Regulation or Directive that that stipulated in the "Summarised Table of requirements for vehicles" will be acceptable for IVA examination.

Where evidence of compliance is supplied, and no obvious modification has been carried out – assume compliance has been met.

The physical examination criterion for this part of the process is contained in sections 1 to 69 of this manual.

Scope of inspection

The design and construction requirements applicable to new road vehicles are contained within the Road Vehicles (Approval) Regulations 2020. The inspection procedures within this manual have been developed to assess as far as practicable the ability of the vehicle to comply with those Regulations. This manual is however not a legal interpretation of the Regulations.

The issue of an Approval Certificate should not be taken as absolute evidence that the vehicle can legally be used on the road, since there may be other applicable requirements contained in other regulations.

Examiners are not required to carry out a roadworthiness inspection, but where obvious safety defects are noted the vehicle may be subject to prohibition action, The IVA certificate will not be issued and where applicable it may be indicated on the IVA 30 (refusal to issue a certificate) that a relevant section of the inspection was “Unable to be assessed fully” due to the condition of an item.

The condition of an item in isolation is not a reason for an item failing to meet the requirements. However, if the condition of an item is such that a meaningful assessment cannot be made, then the IVA 30 should indicate that the applicable section/area was unable to be assessed and state the reason for this action.

NOTE: The vehicle will be assessed for compliance in all modes of operation (as required for normal road use), for example, in the case of a lifting axle, with the axle up and down / if dual fuelled, when running on each separate fuel source etc unless otherwise specified.

Method of Inspection

The examination will be limited to parts of the vehicle which can be readily seen without dismantling. However, the presenter might be required to open lockable compartments and remove engine covers, inspection/access panels, trims, or carpeting, etc. and tilt the vehicles cab in order to gain access to items subject to examination.

The visual assessment of certain items e.g., seat belt anchorages (which in Type Approval undergo a physical test) might not always be sufficient to satisfy the examiners that the vehicle complies with the requirements of the regulations. In such circumstances the onus is on the applicant to demonstrate, for example, by the production of satisfactory test result documentation, or (by arrangement), during construction, of the inspection of relevant structural elements, that the vehicle complies with the requirements of the regulations.

In some areas of the inspection, evidence that the vehicle complies with the relevant criteria may be submitted in the form of documentation. This can, for example, be satisfactory evidence that the vehicle complies with the relevant requirements of a European Directive.

For any technical subject, an appropriate type-approval certificate or a test report from a recognised test house will be accepted as an alternative provided that the vehicle can be identified as belonging to the type to which the documentation refers.

In certain cases, calculations will be required to prove compliance. Where these are required they should be submitted with the application for inspection to Technical Services Branch for verification prior to the inspection. Failure to produce these calculations may delay or prohibit the inspection appointment being confirmed.

If the examiner has any doubts over any item covered by documentary evidence, calculations, or declarations, they have the right to ask for the original copies of these approvals / declarations which were accepted at time of application, to compare against the vehicle they are inspecting.

Use of this manual

The manual has been arranged in the same order to reflect the Framework Regulation from which the inspection criteria are derived. Each inspection area broadly covers the requirements that vehicles must meet or exceed based upon the National IVA scheme.

General Construction is a section that does not explicitly exist in EWVTA, rather it is implicit that unsafe vehicles are not permitted to be approved.

Note: For areas where documentary evidence is not required all vehicles will be subject to a visual inspection as detailed within the method of inspection.

Special Purpose Vehicles. (SPV)

Certain vehicles are classified as Special Purpose Vehicles They may be subject to additional exemptions from the required standards but only where the special function of the vehicle makes it impossible to comply.

a. Armoured Vehicle

A vehicle intended for the protection of conveyed passengers and/or goods and complying with armour plating anti-bullet requirements.

"Anti - bullet requirements" shall be interpreted as meaning: the driver and passenger compartment (front, rear and sides including doors and glazing are capable of withstanding ballistic penetration from small arms fire. E.g., materials to EN 1063 or an equivalent level of protection.

b. Mobile Crane (see Special Types General Order Section below)

A vehicle of N3 category not fitted for the carriage of goods, provided with a crane whose lifting moment is equal to or higher than 400kNm.

(Evidence from the crane manufacture will be required)

c. Snow Plough

A vehicle designed for clearing snow and ice from roads,

d. Recovery Vehicle (see Special Types General Order Section below)

A vehicle fitted with equipment to lift a vehicle partly off the ground and tow it, and not able to carry any other load other than necessary equipment;

e. Electric Vehicle

A vehicle powered purely by electricity and designed for a special purpose (e.g., milk float).

f. Road Sweeper

A vehicle fitted with specialised equipment for sweeping streets.

(Purpose-built compact road sweepers are exempt from approval if they can be classed as mobile machinery and comply with the relevant requirements for such machinery)

g. Abnormal Indivisible Load Vehicle (see Special Types General Order Section below)

A vehicle which is designed to carry loads which are over the maximum vehicle dimensions or weights specified in Section 48.

N.B. Vehicles fitted with specialised equipment may be subject to additional exemption where specified in the EC Framework Directive on items normally assessed by visual inspection only, (i.e., not subject to mandatory Directive compliance.) Applicants requesting such exemptions should at the time of application, submit to DVSA any vehicle specific documentary evidence supporting any such request.

Special Types General Order

The following special vehicles that are regulated under Great Britain's legislation for *special* (including extra-large) vehicle types ("STGO") fall in scope of this manual:

- a. **Abnormal Indivisible Load (AIL) vehicles** – vehicles that are designed to carry a bulky or heavy load that cannot safely be carried on regular vehicles meeting the 'normal' regulations C&U and Authorised weight regulations.

Quick summary table

	Normal size	Wide (> 2.55m or 2.75m for locomotive), and/or long (> 12m)	Super-size: >6.1m wide, or 30m long
Normal weight	C&U	STGO (Cat 1)	VSO
Cat 1 weights: <50T (std axle weights)	Plating & Testing*, STGO	STGO	VSO
Cat 2 <80T	P&T*, STGO	STGO %	VSO
Cat 3 <150T	P&T*, STGO	STGO %	VSO
Exceeds 150T	STGO	STGO %	VSO

* - unless a locomotive

% - exempt from Spray suppression

- b. **Road Recovery Vehicle (RRV)** – an N3 vehicle or combination of vehicles (N3/O4) used to lift and recover another vehicle, where the normal C&U limits are exceeded, and intended to be taxed as a recovery vehicle.
- c. **Engineering plant (EP)** – vehicles based on lorry chassis which do not carry any goods, only fixed machinery, or equipment, and which are not cranes. It must not be possible for the engineering function to be carried out by a vehicle complying in all respects with C&U regulations. Some vehicles commonly classed as plant or *engineering plant* (e.g., JCB diggers, excavators.) which are not based on a lorry chassis are classed as *Mobile Machinery* and exempt from approval or IVA.
- d. **Mobile Cranes (MC)** – vehicles based on a lorry chassis which includes extremely large elevating work platforms as well as more typical cranes. These vehicles only fall in scope of STGO where they exceed the normal dimensions and weights of a road vehicle. (A van-based elevating work platform is not within STGO).

In addition, this manual covers two other categories planned for inclusion in STGO which at present still require a Vehicle Special Order (VSO) to authorise each vehicle

- e. Impact protection vehicles (Crash Cushion)** – vehicles specially designed for use in high-speed traffic (e.g., laying out cones on the motorway) with a protective deployable rear “crash cushion”.
- f. Crane ballast vehicles** – vehicles designed to carry the ballast required by mobile cranes. These are carrying a divisible load which is very heavy but nevertheless are permitted in the interests of avoiding the need for two or more vehicles carrying ballast to follow the crane.

Refusal to examine

The examination of a vehicle may be refused for any of the following reasons

- the vehicle is not submitted for examination at the time and place appointed
- the correct fee has not been paid
- the vehicle submitted for examination is of the incorrect category
- the vehicle cannot be driven or has insufficient fuel or oil to enable the test to be completed
- the vehicle is presented in a dirty or dangerous condition such as to make it unreasonable for the examination to be carried out
- a load or items on the vehicle are not secured or removed as requested
- a proper examination cannot be carried out because any door, tailgate, boot lid, engine cover, fuel cap or other device designed to be readily opened cannot be opened
- the condition of the vehicle (in the opinion of the examiner) is such that proper examination of the vehicle would involve a danger of injury to any person or damage to the vehicle or any other property
- there was no means of identifying the vehicle, i.e., the vehicle identification number was missing or did not relate to the vehicle, or where evidence indicates that the VIN has been tampered with to change the identity of the vehicle
- the presenter does not remain in the vehicle or its vicinity and operate the controls, drive the vehicle or to remove, refit panels as requested to allow a meaningful examination of the vehicle or is uncooperative.

Run Locks

Vehicles fitted with Run Lock systems will be checked for correct operation only. Presenters are reminded to inform their insurance provider where these devices are fitted.

Summarised Table of Directive Requirements for Heavy Vehicles

Section Number	Directive Requirement	As amended by #	UNECE Regulations #	N2 & N3	
01	Noise	70/157/EEC	1999/101/EC	51.02	Approval & Inspection
02	Emissions	70/220/EEC / 88/77/EEC	See Section	83.05 & 49.04	Approval
03	Fuel tank & rear under-run	70/221/EEC	2006/20/EC	34.02 & 58.01	Approval & Inspection
04	Rear registration plate space	70/222/EEC			Inspection
05	Steering effort	70/311/EEC	1999/07/EC	79.01~ / 79.03~	Approval / Inspection
06	Door latches & hinges	70/387/EEC	2001/31/EC	11.02	Inspection
07	Audible warning	70/388/EEC	87/354/EC	28.00	Inspection
08	Indirect vision	2003/97/EC		46.04*	Approval* & Inspection
09	Braking	71/320/EEC	98/12/EC	13.08	Approval
10	EMC	72/245/EEC	2006/28/EC	10.03	Approval
13	Anti-theft	74/61/EEC	95/56/EC	18.02 / 97.00 / 116.00 161 / 162 / 163	Inspection
15	Seat strength	74/408/EEC	2005/39/EC	80.01	Inspection
17	Speedo & reverse gear	75/443/EEC	97/39/EC	39.00	Inspection
18	Statutory plates	76/114/EEC	78/507/EEC		Inspection
19	Seat belt anchorages	76/115/EEC	2005/41/EC	14.05	Inspection
20	Installation of lighting and signalling devices			48.03	Inspection
21	Retro reflectors			3 / 150 / 104	Inspection
22	End outline, position, stop & side marker lamps			7 / 148	Inspection
23	Direction indicators			6 / 148	Inspection
24	Rear registration plate lamps			4 / 148	Inspection
25	Headlamps			8 / 20 / 31 / 98 / 112 / 123 / 149	Inspection
25A	Cornering Lamps			119 / 149	Inspection

Section Number	Directive Requirement	As amended by #	UNECE Regulations #	N2 & N3
26 Front fog lamps			19 / 149	Inspection
27 Tow hooks	77/389/EEC	96/64/EC		Inspection
28 Rear fog lamps			38 / 148	Inspection
29 Reversing lamps			23 / 148	Inspection
30 Parking lamps			77 / 148	Inspection
31 Seat belts	77/541/EEC	2005/40/EC	16.04	Inspection
33 Identification of controls	78/316/EEC	94/53/EC	121.00	Inspection
34 Defrost / Demist				Inspection
35 Wash / Wipe				Inspection
36 Heater systems	2001/56/EC	2006/119/EC	122.00	Inspection
42 Lateral protection	89/297/EEC		73.00	Inspection
43 Spray suppression systems	91/226/EEC			Inspection >7.5t
45 Safety Glass			43:00	Inspection
46 Tyres	92/23/EEC	2005/11/EC	30.02 / 54.00 / 64.01 / 117.01	Inspection
47 Speed limiter	92/24/EEC	2004/11/EC	89.00	Inspection
48 Masses & Dimensions	97/27/EC	2003/19/EC		Inspection
49 External projections of Cabs	92/114/EEC		61.00	Inspection
50 Couplings	94/20/EC		55.01	Inspection
57 Front under-run protection	2000/40/EC		93.00	Approval / Inspection
62 Hydrogen Powered Motor Vehicles	Reg (EC) 79/2009	EU/406/2010	134	Approval
65 Advanced emergency braking systems	EU. 347/2012		131	
66 Lane departure warning systems	EU 351/2012		130	
69 Electrical Safety			100.01	Approval / Inspection

Footnotes

Vehicles may be approved to a later level Directive or regulation; these approvals will be acceptable.

* N2 and N3 vehicles manufactured after 1st April 2016 require approval to this Regulation for installation.

~ Regulation 79.01 is applicable to vehicles fitted with 'full-power' steering systems, such as 'steer-by-wire', as opposed to conventional 'power-assisted' systems. Regulation 79.03 is applicable to vehicles fitted with systems that are capable of controlling the longitudinal and lateral motion of the vehicle on a sustained basis. This is defined as an 'Automatically Commanded Steering Function (ACSF)' in the Regulations, which covers systems that operate above 10 km/h and are capable of controlling a vehicle at constant speed (slowing down for other traffic when necessary), while keeping the vehicle in the centre of the lane, with minimal or no driver input. Compliance to Regulation 79 for steer-by-wire systems is required to be in the form of evidence provided from the vehicle manufacturer or system developer in the form of:

- An approval to R79.01.S3 or later, with sufficient attached documentation to confirm it covers the steer-by-wire system and applies to the vehicle presented, or
- A test report to R79.01.S3 or later from a recognised Technical Service, with sufficient attached documentation to confirm that it covers the steer-by-wire, it applies to the vehicle presented, confirms compliance of the steer-by-wire system, and includes the required documentation relating to Annex 6.

Note: Regulation 79, Annex 6 requires provision of information on the system and its safety concept, therefore direct involvement of the vehicle manufacturer or system developer must be evidenced.

Record of Revision

Revision	Date	Description of Change
1	24/04/2009	
2	16/08/2010	Add Regulations to the Table of summarised requirements, add new statement to foreword
3	31/01/2011	Add text to foreword, redefine Modes of Operation
4	30/04/2012	Add statement for SPV, Change text in the list of IVA 12 items for identification of vehicle
5	03/02/2014	Amend definitions of Electric Vehicle and Small Road Sweeper
6	29/10/2014	DVSA replaces VOSA, STGO information added
7	01/09/2015	Addition of electric vehicles and amendments to text
8	10/04/2018	Revise table of summarised requirements to account for later Directives/Regulations, Run lock added, Special equipment note added, Add later directive info, Foreword Remove example, Foreword Add approval certificate info.
9	01/07/2018	Add sections 65 and 66 (AEBS & LDWS)
10	01/09/2020	Update Directives/Regulations list.
11	28/11/2025	Regulation 13H removed from 09 Braking, Summarised Directive Requirements. 'Summarised List of Requirements' table, 05 Steering Effort: Added UNECE Regulations reference to new table footnote in respect of steer-by-wire systems (TSE N2N3 FWD 001). 'Run Lock' paragraph revised.
12	11/05/2026	Updated wording at obligatory approval certificates paragraph. Added acceptable UNECE Regulations to Item 13, Summarised table of Directive Requirements. Item 69 title corrected.

Age-Related IVA

IVA for N2/N3 Vehicles manufactured before 29th April 2009 up to a maximum of 25 years old

Purpose of this document

To describe the policy and procedures for IVA to be followed in order for N2/N3 vehicles up to 25 years old to become approved for registration following the implementation of ECWVTA. Vehicles over 25 years old do not require type approval or IVA before registration, although they will require submission to DVSA for a Plating examination and first annual test. (unless manufactured before 1968).

Previously used vehicles under IVA

An application will be assessed to make sure that the vehicle receives the correct level of inspection:

- N2 or N3 vehicle manufactured on or after the introduction of the Road Vehicles (Approval) Regulations 2009 will be required to meet the standards as laid down by the approval regulations (April 29th, 2009).
- N2 or N3 vehicles manufactured before 29th April 2009 will be eligible for IVA using Retrospective Directive Requirements.

Ethos of IVA for older vehicles

Vehicles (up to 25 years old) which can no longer be approved via the GVNTA route will now require to be approved using the IVA scheme, these vehicles will also be subject to an Annual Test (MOT) or if exempt Testing and Plating a full roadworthiness check.

Scope of IVA inspection carried out on vehicles up to 25 years old

Importantly, most elements of the current IVA inspection (latest levels as per RVAR 2009) will apply, with only the 6 areas covered by GVNTA differing from the conventional IVA requirements, these Age-related standards are detailed below. All age-related exemptions are shown in the relevant sections of the IVA Manual.

Vehicles will be tested based on their date of manufacture. Where only the **year** of manufacture is known, assume a date of 1 January in the relevant year. For vehicles which have been previously used overseas or by the armed forces, the date of manufacture should be used as the “date of first use” when submitted for annual inspection.

Scope of Goods Vehicle National Type Approval GVNTA

GVNTA covers 6 main areas of compliance. These are;

- Emissions (Diesel and Petrol, including Smoke for diesels)
- Radio interference suppression
- Brakes
- Noise
- Speed Limiter
- Tyre Noise

Additional Information

A provisional Technical Record will have been created for this type of vehicle, and a plating exercise is required. On completion of the exercise the IVA Certificate number must be entered in the notes section of the provisional record before it is changed to confirmed.

A Plating Certificate **VTG6A / VTG7A** should be issued where required.

Pre-April 2009 vehicles require only an installation check of the Rear under-run protective device as per Section 03B of this manual.

Vehicles manufactured from 10th July 2011 must be fitted with Conspicuity Markings meeting the requirements of Section 21 of this manual.

Age-Related Directive Requirements for Heavy Vehicles up to 25 years old				
Section Number	Directive Requirement	As amended by #	UNECE Regulations	N2 & N3
1 Noise				
29/04/2009 IVA Requirement	70/157/EEC	1999/101/EC	51.02	Approval
Vehicles manufactured on or after 1 st January 1987:	70/157/EEC	77/212/EEC	51.00	
Vehicles manufactured on or after 1 st October 1990:	70/157/EEC	84/424/EEC	51.01	
Vehicles manufactured on or after 1 st October 1996:	70/157/EEC	92/97/EEC	51.02	
2 Emissions				
29/04/2009 IVA Requirement	70/220/EEC	See Section	83.05	Approval
Light Duty				
Vehicles manufactured on or after 1 st January 1987:	70/220/EEC	83/351/EEC	15.04	
Vehicles manufactured on or after 1 st October 1989:	70/220/EEC	88/76/EEC	83.00	
Vehicles manufactured on or after 1 st October 1990:	70/220/EEC	88/436/EEC	83.00	
Vehicles manufactured on or after 1 st October 1994:	70/220/EEC	93/59/EEC (Euro 1)	83.02	
Vehicles manufactured on or after 1 st October 1998:	70/220/EEC	96/69/EEC (Euro 2)	83.04	
Vehicles manufactured on or after 1 st January 2002:	70/220/EEC	98/69/EEC Row A Limits apply (Euro 3)	83.05	
Vehicles manufactured on or after 1 st January 2007:	70/220/EEC	98/69/EEC Row B Limits apply (Euro 4)	83.05	

Section Number	Directive Requirement	As amended by #	UNECE Regulations	N2 & N3
8 Indirect vision				
29/04/2009 IVA Requirement	2003/97/EC		46.02	Inspection
Vehicles manufactured on or after 1 st January 1987:	71/127/EEC	79/795/EEC	46.01	
Vehicles manufactured on or after 1 st October 1988:	71/127/EEC	85/205/EEC	46.01	
Vehicles manufactured on or after 1 st October 1990:	71/127/EEC	88/321/EEC	46.01	
Vehicles manufactured on or after 1 st January 2000:	71/127/EEC	88/321/EEC or 2003/97/EC	46.01 or 46.02	
9 Braking				
29/04/2009 IVA Requirement	71/320/EEC	98/12/EC	13.08 / 13H	Approval
Vehicles manufactured on or after 1 st January 1987:	71/320/EEC	79/489/EEC	13.04	
Vehicles manufactured on or after 1 st October 1988:	71/320/EEC	85/647/EEC	13.05	
Vehicles manufactured on or after 1 st October 1991:	71/320/EEC	88/194/EEC	13.06	
Vehicles manufactured on or after 1 st October 1994:	71/320/EEC	91/422/EEC	13.07	
Vehicles manufactured on or after 31 st March 2001:	71/320/EEC	98/12/EC	13.08	
10 EMC				
29/04/2009 IVA Requirement	72/245/EEC	2006/28/EC	10.03	Approval
Spark Ignition Engines Only				
Vehicles manufactured on or after 1 st January 1987:	72/245/EEC		10.01	

Section Number	Directive Requirement	As amended by #	UNECE Regulations	N2 & N3
Vehicles manufactured on or after 1 st October 2002:	72/245/EEC	95/54/EC	10.02	
Vehicles manufactured on or after 1 st January 2009:	72/245/EEC	2004/104/EC	10.03	
11 Diesel Smoke				
29/04/2009 IVA Requirement	72/306/EEC	2005/21/EC		Inspection
Vehicles manufactured on or after 1 st January 1987:	72/306/EEC		24.03	
	Or 2005/55/EC	2008/74/EC		
	Or 715/2007	692/2008		
	Or A free acceleration test such that the coefficient of absorption of the exhaust emissions from the engine immediately after leaving the exhaust shall not exceed - (a) if the engine of the vehicle is turbo-charged, 3.0 per metre, or (b) in any other case, 2.5 per metre.			
41 Diesel Emissions				
29/04/2009 IVA Requirement	88/77/EEC	See Section	49.04	Approval
Heavy Duty				
Vehicles manufactured on or after 1 st October 1990:	88/77/EEC	(Euro 0)	49.01	
Vehicles manufactured on or after 1 st October 1993:	88/77/EEC	91/542/EEC Row A Limits apply (Euro I)	49.02	
Vehicles manufactured on or after 1 st October 1996:	88/77/EEC	91/542/EEC Row B Limits apply (Euro II)	49.02	

Section Number	Directive Requirement	As amended by #	UNECE Regulations	N2 & N3
Vehicles manufactured on or after 1 st October 2001:	88/77/EEC	1999/96/EC Row A Limits apply (Euro III)	49.03	
Vehicles manufactured on or after 1 st October 2006:	2005/55/EC Row B1 Limits apply	(Euro IV)	49.04	
Vehicles manufactured on or after 1 st October 2009:	2005/55/EC Row B2 Limits apply	(Euro V)	49.05	
46 Tyres				
29/04/2009 IVA Requirement	92/23/EEC	2005/11/EC	30.02 / 54.00 / 64.01 / 117.01	Inspection
Vehicles manufactured on or after 4 th February 2005:	92/23/EEC	2005/11/EC	117.00	
47 Speed limiter				
29/04/2009 IVA Requirement	92/24/EEC	2004/11/EC	89.00	Inspection
Vehicles manufactured on or after 1 st October 1994:	92/24/EEC	2004/11/EC	89.00	
57 Front under-run protection				
29/04/2009 IVA Requirement	2000/40/EC		93.00	Inspection
Vehicles manufactured on or after 10 th August 2003:	2000/40/EC		93.00	
	Or A device for which an approval or test report has been issued, or a test has been witnessed by the approval authority with respect to the requirements of 200/40/EC or UNECE 93.00 And an installation check			

Vehicles may be approved to a later level directive; these approvals will be acceptable.

The above table lists the “Age-related Standards” which will be applied to vehicles presented for this scheme. Under items noted as “Inspection”, an Approval can be provided instead, as an alternative.

Record of Revision

Revision	Date	Description of Change
1	31/07/2011	New Section
2	11/02/2013	Change to Definitions for N2/N3 new or used vehicles
3	03/02/2014	Insert new statements under the header "Additional Information".
4	29/10/2014	DVSA replaces VOSA
5	01/09/2015	Amendments to text, additions, and deletions to simplify the content
6	10/04/2018	Text standardised.

01 Noise

Application: All Vehicles (Electric Vehicles – RS7 only)

Method of Inspection	Required Standard
<p>The examiner will ensure that the evidence is relevant to the vehicle as presented for test.</p> <p>Note 1: Only a minor modification to the exhaust system is allowed. A minor modification means:</p> <ul style="list-style-type: none"> • Any change to the pipe diameter or length (of more than 2 meters) after the last silencer. • Any change of the exhaust pipe length forward of the last silencer. • Any significant change in the direction that the exhaust pipe outlet faces, i.e., the original outlet to the offside is now positioned to the rear. <p>If modified, the noise must be assessed with a static noise test. Alternatively, compliance may be demonstrated by submission of a test report from an approved technical service.</p> <p>For any change other than to pipe work length, i.e., a new silencer or other equipment, or a change in pipe diameter pre-emissions control, a new approval test will be required.</p> <p>Note 2: STGO Categories - Abnormal Indivisible Load (with a GTW of at least 120,000kg) and Road Recovery Vehicles do not have to comply with RS 1, but must meet RS 2 - 8</p> <p>Note 3: An auxiliary engine will not be subject to the IVA Noise requirement.</p> <p>Note 4: Manufacturers drain holes are permitted in the system.</p>	<ol style="list-style-type: none"> 1. The vehicle as presented must be accompanied by satisfactory evidence of compliance with the required standard for "Noise" (see Notes 1, 2 & 3) 2. The exhaust system must be fitted with a silencer. 3. The exhaust system must be securely mounted. 4. Exhaust system components must be secure. 5. The exhaust outlet must be positioned so that exhaust gases cannot damage other components of the vehicle or cause a hazard to people in the vehicle. 6. There must be no leaks from the exhaust system (see Note 4). 7. Where an air braking system has been modified, any high-pressure brake exhaust outlet must be fitted with a silencer, or satisfactory evidence supplied to show compliance with the required standard. (see Note 5). <p>Where the exhaust system is subject to modification</p> <ol style="list-style-type: none"> 8. The measured sound level must not exceed 99dbA (see Notes 1, 6, & 7).

Method of Inspection	Required Standard
<p>Note 5: Where a modification has been carried out to the air braking system a test report must confirm that the vehicle complies with the directive listed in the front of this manual or an inspection to confirm that air brake silencers are fitted to all additional or modified air brake exhaust outlets.</p> <p>Note 6 : Where examiners are required to undertake a noise test, they should refer to the appropriate work instruction for details of how the test should be conducted.</p> <p>Note 7: Where the examiner has doubts that the vehicle noise test result may be falsely low then evidence of compliance must be supplied.</p>	

Record of Revision

Revision	Date	Description of Change
1	24/04/2009	
2	31/07/2011	Remove noise test procedure from MOI and add notes 4 & 5
3	29/10/2014	New note 2 (STGO), old notes 2 – 5 renumbered 3 - 6
4	01/09/2015	Addition of Note 7
5	10/04/2018	Amend note 7
6	20/10/2023	Revise application: Electric Vehicles – RS7 only
7	28/11/2025	Note 1 revised. Revised heading to RS8 & added reference to Note 1 (TSE N2N3 001 001).

This page intentionally left blank

02 Emissions

Application: All Vehicles fitted with piston engines used for the propulsion of the vehicle

Method of Inspection	Required Standard																								
<p>Ensure that the vehicle as presented has satisfactory evidence of compliance to the required standard and has not been subject to modifications that may invalidate the approval.</p> <p>Age-related Directive requirements for heavy vehicles up to 25 years old are detailed in the Age-Related IVA section.</p> <p>An EC type-approval issued to the most representative base vehicle remains valid irrespective of change in reference weight. (e.g., due to addition of armour plating).</p> <p>Where evidence of compliance has been provided, subsequent modification to the exhaust system will be permitted providing:</p> <ul style="list-style-type: none"> • it is to the exhaust system after the last silencer; and • the emissions control device is identical to that fitted before the modification. (as listed on an original approval or test report). <p>This is not applicable to Age-related IVA vehicles as normal wear and tear is most likely to have resulted in exhaust system replacement.</p> <p>STGO - Abnormal Indivisible Load Vehicles (GTW of at least 120,000kg) only require a declaration from the engine manufacturer that the required standard is met, i.e., Euro 5.</p>	<ol style="list-style-type: none"> 1. An N2 vehicle as presented must be accompanied by satisfactory evidence of compliance with the required standard for either 'Light duty emissions', or Heavy duty 'Emissions'. (See Table 1 & Note 1). 2. An N3 vehicle as presented must be accompanied by satisfactory evidence of compliance with the required standard for 'Heavy duty Emissions'. (see Table 1 and Note 1). 3. The exhaust must not emit excessive smoke or vapour of any colour to an extent likely to obscure the vision of other road users. <p>Table 1 (see also Age-Related IVA section)</p> <table border="1" data-bbox="1021 817 2096 1278"> <thead> <tr> <th colspan="4" data-bbox="1021 817 2096 873">Light Duty Emissions (N2 only)</th> </tr> <tr> <th data-bbox="1021 873 1332 948">Manufactured Date (TBD) (see Note 1)</th> <th data-bbox="1332 873 1579 948">Directive Requirement</th> <th data-bbox="1579 873 1796 948">As amended by</th> <th data-bbox="1796 873 2096 948"></th> </tr> </thead> <tbody> <tr> <td data-bbox="1021 948 1332 1023"></td> <td data-bbox="1332 948 1579 1023">70/220/EEC</td> <td data-bbox="1579 948 1796 1023">2003/76/EC</td> <td data-bbox="1796 948 2096 1023">Row B Limits apply (Euro 4)</td> </tr> <tr> <td data-bbox="1021 1023 1332 1106">Vehicles on or after 1st January 2012</td> <td data-bbox="1332 1023 1579 1106">Reg (EC) 715/2007</td> <td data-bbox="1579 1023 1796 1106"></td> <td data-bbox="1796 1023 2096 1106">Annex I Table 2 (Euro 5)</td> </tr> <tr> <td data-bbox="1021 1106 1332 1189">Vehicles on or after 1st September 2016</td> <td data-bbox="1332 1106 1579 1189">Reg (EC) 715/2007</td> <td data-bbox="1579 1106 1796 1189"></td> <td data-bbox="1796 1106 2096 1189">Annex I Table 1 (Euro 6)</td> </tr> <tr> <td data-bbox="1021 1189 1332 1278">Vehicles on or after 1st March 2020</td> <td data-bbox="1332 1189 1579 1278">Reg (EU) 2017/1151</td> <td data-bbox="1579 1189 1796 1278"></td> <td data-bbox="1796 1189 2096 1278">WLTP</td> </tr> </tbody> </table>	Light Duty Emissions (N2 only)				Manufactured Date (TBD) (see Note 1)	Directive Requirement	As amended by			70/220/EEC	2003/76/EC	Row B Limits apply (Euro 4)	Vehicles on or after 1 st January 2012	Reg (EC) 715/2007		Annex I Table 2 (Euro 5)	Vehicles on or after 1 st September 2016	Reg (EC) 715/2007		Annex I Table 1 (Euro 6)	Vehicles on or after 1 st March 2020	Reg (EU) 2017/1151		WLTP
Light Duty Emissions (N2 only)																									
Manufactured Date (TBD) (see Note 1)	Directive Requirement	As amended by																							
	70/220/EEC	2003/76/EC	Row B Limits apply (Euro 4)																						
Vehicles on or after 1 st January 2012	Reg (EC) 715/2007		Annex I Table 2 (Euro 5)																						
Vehicles on or after 1 st September 2016	Reg (EC) 715/2007		Annex I Table 1 (Euro 6)																						
Vehicles on or after 1 st March 2020	Reg (EU) 2017/1151		WLTP																						

Method of Inspection	Required Standard			
<p>Note 1: A mobile crane may comply with either Directive 2006/42 for Non-Road Mobile Machinery emissions or Regulation (EU) 2016/1628, as an alternative to the listed emissions standards.</p>	Heavy Duty Emissions (N2 & N3)			
	Manufactured Date	Directive Requirement	As amended by	
	Vehicles, before 1 st October 2009	88/77/EEC	1999/96/EC	Row B1 Limits apply (Euro IV)
	Vehicles, on or after 1 st October 2009	88/77/EEC	99/96/EC	Row B2 Limits apply (Euro V)
	Vehicles on or after 1 st September 2018	(EC) 595/2009		Annex I limit values (Euro VI)

Record of Revision

Revision	Date	Description of Change
1	24/04/2009	
2	16/08/2010	Add table to RS 1.
3	31/07/2011	Amend table and reword note 1.
4	29/10/2014	STGO information added to Mol.
5	01/09/2015	Add in the proposed Euro 6 dates.
6	01/07/2018	Table 1 updated, Note1 removed, Note 2 renumbered.
7	01/09/2020	Update Mol (TSE N2 N3 02 001).
8	28/11/2025	Added reference to Age-related section to Mol. Table 1 formatted.
9	11/05/2026	Added reference to Note 1 from RS 1 & revised Note 1 to include alternative compliance (TSE IVA N2N3 002 002).

This page intentionally left blank

03A Fuel Tanks

Application: All Vehicles

Method of Inspection	Required Standard
<p>Ensure that the vehicle as presented has satisfactory evidence of compliance to the required standard and carry out an installation check ensuring there appears to be no modifications present that would invalidate the evidence.</p> <p>Fuel Tanks The requirements for liquid fuel tanks apply only to fuel tanks used primarily for the propulsion of the vehicle.</p> <p>Vehicles that require an Age-related IVA only have to comply with the Installation Check.</p> <p>The required standard for Gaseous Fuels:</p> <p>ECE 67.01 – LPG fuel systems. or</p> <p>ECE 115.00 – Retrofit LPG fuel systems</p> <ul style="list-style-type: none"> Requires compliance with the installation requirements of ECE 67.01. or <p>An Installation Certificate from an Approved Installation Engineer;</p> <p>A Comparable Standard for LPG ECE 110.00 – CNG fuel systems, or</p> <p>ECE 115.00 – Retrofit CNG fuel systems</p> <ul style="list-style-type: none"> Requires compliance with the installation requirements of ECE 110.00, or 	<ol style="list-style-type: none"> The vehicle as presented must be accompanied by satisfactory documentary evidence with the required standard for “Fuel Tanks.” (see Note 1). <p>Installation Check</p> <ol style="list-style-type: none"> A fuel tank must not be located in, or form part of an occupant compartment or other compartment integral with it. There must not be an aperture in a partition separating the occupant compartment from the fuel tank that would allow fuel to flow freely into the occupant compartment during normal conditions of use. The fuel filler opening must not be located in the occupant, luggage, or engine compartment. The fuel tank must be securely attached to the vehicle. The fuel tank must be positioned so it is protected from damage from protruding parts or sharp edges in the event of a front or rear impact. The fuel tank must be mounted so as not to be fouled by moving parts of the vehicle, or likely to be subject to abrasion by adjacent parts. The tank must not be mounted in a position that would allow any fuel leaking from the tank or pipe work into the occupant compartment. Any fuel filler neck or vent must not allow spilt fuel to be able to fall onto the exhaust system.

Fuel Tanks 03A

Method of Inspection	Required Standard
<p>An Installation Certificate from an Approved Installation Engineer</p> <p>A Comparable Standard for CNG Check that an Approval / Test Report is presented with the vehicle and that there appears to be no modifications that would invalidate the evidence.</p> <p>Note 1: Check that an Approval/Test Report is presented with the vehicle and that there appears to be no modifications that would invalidate the evidence.</p> <p>Note 2: The cap and venting device must be those approved for the tank such that only the pipe work between them, and the tank may be modified.</p> <p>Note 3: Hydrogen fuelled vehicles Check that an Approval / Test Report is presented with the vehicle and that there appears to be no modifications that would invalidate the evidence of compliance with the technical provisions of either:</p> <p>Regulation (EC) 79/2009, or</p> <p>UN ECE Regulation 134</p>	<p>10. An approved vent device must be fitted to the fuel tank.</p> <p>11. An approved fuel filler cap must positively locate to the filler neck and incorporate an adequate sealing arrangement so that a fuel leak is not possible (see Note 2).</p> <p>12. The fuel filler cap must either be tethered to the vehicle or be of a lockable type where the key can only be removed when the cap is locked or an automatically opening and closing, non-removable fuel filler cap.</p> <p>Hydrogen fuelled vehicles</p> <p>13. The vehicle as presented must be accompanied by satisfactory documentary evidence for Hydrogen fuel systems (including storage tanks)(see Note 3).</p>

Record of Revision

Revision	Date	Description of Change
1	24/04/2009	
2	16/08/2010	Amend RS 12, link note 2 to RS11 and reword RS4
3	31/01/2011	Delete Note and add text to MOI
4	30/04/2012	Add statement to Mol for ARIVA
5	01/09/2015	Incorporate Liquefied Natural Gas (LNG) requirements with CNG
6	10/04/2018	Various updates
7	01/07/2018	Addition of Hydrogen legislation
8	01/09/2020	Delete duplicate RS, add header for Hydrogen requirements.
9	20/10/2023	Removal of outdated directives in Mol. Addition of RS13 and Note 3 to clarify Hydrogen requirements.

This page intentionally left blank

03B Rear Protective Devices (Under-Run)

Application: All Vehicles

Method of Inspection	Required Standard								
<p>Ensure the vehicle or device as presented is accompanied by satisfactory evidence in the form of:</p> <ul style="list-style-type: none"> • a type approval <p>(If a valid vehicle approval relating to the vehicle in its finished unmodified state is provided the installation check is not required)</p> <p>or</p> <ul style="list-style-type: none"> • a test report witnessed by an Approval Authority • a test report issued by an Approved Technical Service • evidence that calculations were provided at the time of application to the satisfaction of the Approval Authority. <p style="padding-left: 40px;">and in these cases, an Installation check is required.</p> <p>Vehicle Exemptions **</p> <table border="1" style="width: 100%; border-collapse: collapse; margin-top: 10px;"> <thead> <tr style="background-color: #cccccc;"> <th style="width: 50%; text-align: center;">Vehicle type</th> <th style="width: 50%; text-align: center;">Exemption Provided</th> </tr> </thead> <tbody> <tr> <td>Tractors for articulated vehicles</td> <td style="text-align: center;">Exempt</td> </tr> <tr> <td>Gritter (vehicle fitted at the rear with apparatus for spreading material on a road)</td> <td style="text-align: center;">Exempt</td> </tr> <tr> <td>Vehicle transporters (vehicles specially designed and constructed to carry other vehicles loaded on from the rear)</td> <td>Exempt if the lower edge of the loading platform / bed structure is 550mm or less</td> </tr> </tbody> </table>	Vehicle type	Exemption Provided	Tractors for articulated vehicles	Exempt	Gritter (vehicle fitted at the rear with apparatus for spreading material on a road)	Exempt	Vehicle transporters (vehicles specially designed and constructed to carry other vehicles loaded on from the rear)	Exempt if the lower edge of the loading platform / bed structure is 550mm or less	<p>Approval</p> <ol style="list-style-type: none"> 1. The vehicle as presented must be accompanied by satisfactory evidence of compliance regarding the protective system (see Note 1 & exemptions). 2. Separate devices must be correctly marked and be as specified in the approval / test report or calculation documents. <p>Installation check (see Note 1)</p> <ol style="list-style-type: none"> 3. Where a separate device is fitted it must be fitted as per manufacturer's instructions. 4. The lower edge of the rear under-run must at no point be more than 550mm above the ground. 5. The width of the rear under-run must not extend beyond the width of the rear axle (see Notes 2, 3 & 4). 6. The width of the rear under-run must extend to within 100mm of the width of the rear axle on either side (see Notes 2 & 3). 7. The rear under-run criteria must be met as close to the rear of the vehicle as possible and must be capable of fulfilling its function (see Note 5). 8. The section height of the rear under-run must not be less than 100mm.
Vehicle type	Exemption Provided								
Tractors for articulated vehicles	Exempt								
Gritter (vehicle fitted at the rear with apparatus for spreading material on a road)	Exempt								
Vehicle transporters (vehicles specially designed and constructed to carry other vehicles loaded on from the rear)	Exempt if the lower edge of the loading platform / bed structure is 550mm or less								

Rear Protective Devices (Under-Run) 03B

Method of Inspection		Required Standard
Vehicle type	Exemption Provided	
Concrete / Volumetric Mixers & pumping vehicles *	Exempt if the operation of equipment is compromised by the fitment of an underrun	<p>9. The outer ends of the rear under-run must be rounded on the outside and have a radius of curvature of not less than 2.5mm.</p> <p>10. The rear under-run must be securely attached to the rear of the vehicle.</p> <p>11. Rear under-run mountings must clearly be of adequate strength to perform their function.</p> <p>12. In the case of a movable rear under-run, the device must be able to be securely locked into the service position.</p> <p>13. In the case of a movable rear under-run, the locking mechanism must be clearly of adequate strength to enable the device to perform its function.</p> <p>Where platform lifts are incorporated into the under-run</p> <p>14. The lateral distance between working elements of the lift and fixed elements of rear under-run must be a maximum of 25mm.</p> <p>15. Each individual section of the rear under-run-must have a rear facing surface area of at least 350cm².</p>
Coal delivery vehicles fitted with a rear mounted conveyor	Exempt if the operation of equipment is compromised by the fitment of an underrun	
Rigid car transporter vehicles	Where the vehicle is permanently fitted with a trailer which facilitates loading of the vehicle and is only detachable for maintenance.	
Skip loaders, including hook lifts	Exempt if the operation of equipment is compromised by the fitment of an underrun OR the upper edge of the loading platform is lower than 550mm OR Where the rear face of the body (between the support legs) is: a) essentially enclosed across the full width of the vehicle, b) the lower edge of the body incorporates a channel/box section across its full width secured at each end and, c) the lower edge is not more than 550 mm above the ground.	
Off road vehicles	Exempt	
Rear loading refuse collection vehicles	Where the equipment and bodywork prevent the fitting of a RUP device.	
Breakdown Vehicle (Rear loading slide and tilt bed)	Exempt when fitted with a Spectacle Lift	

Rear Protective Devices (Under-Run) 03B

Method of Inspection		Required Standard
Vehicle type	Exemption Provided	
Highways Surface/Geological survey vehicles	Exempt where fitment of devices would interfere with the operation equipment	
Access Lift Vehicles	Only where the platform is situated behind the vehicle making the fitment of the rear under-run device impractical	
STGO Exemptions:		
Road Recovery Vehicles,	Exempt where fitment of devices would interfere with the operation equipment	
Vehicles (including STGO) for which rear under-run protection is incompatible with their use are exempt	Evidence may be required	
<p>* In cases where it is impracticable to comply with the full requirements:</p> <ul style="list-style-type: none"> a) the protection device will be mounted as close to the rear as possible and must be capable of fulfilling its function. b) evidence of compliance for the protection device is not required in these cases, and as an installation check, RS4 to RS15 will be applied. <p>** Vehicles designed to interchange equipment for gritting, gully sucking, and tipping, etc., used by local authorities need only comply with Item a) above. All other vehicles with demountable bodies must meet the requirements applicable to their category.</p> <p>Note 1: Evidence may be for a vehicle, a separate device or that the rear of the vehicle is so designed as to perform the same function. Where the rear body is so designed the Installation Inspection as</p>		

Rear Protective Devices (Under-Run) 03B

Method of Inspection	Required Standard
<p>appropriate relates to the structure forming the rear of the vehicle. Pre April 2009 vehicles only require the installation check.</p> <p>Note 2: The width of the rear axle is measured at the outermost points of the wheels including the tyres (excluding any tyre bulging close to the ground). Where more than one rear axle is fitted the width used is that of the widest axle.</p> <p>Note 3: Where the rear under-run is combined with a tail lift the lift structure may extend beyond the width of the rear axle to the width of the body, the requirements for the rear under-run will be considered to be met providing the “device” meets all other dimensions up to the width of the rear axle.</p> <p>Note 4: Where the rear under-run device is contained in or comprises the vehicle bodywork, which itself extends beyond the width of the rear axle, RS5 shall not apply.</p> <p>Note 5: Items above 2m from the ground, shall not be taken into account when determining the RUPD distance from the rear of the vehicle.</p>	

Rear Protective Devices (Under-Run) 03B

Record of Revision

Revision	Date	Description of Change
1	24/04/2009	
2	31/01/2011	Add exemptions
3	30/04/2012	Add more exemptions to Mol
4	03/02/2014	Amend description of car transporter, insert new note 4 and link to RS 5 & 6
5	01/09/2015	Add more exemptions to Mol
6	10/04/2018	Amend exemptions to include rigid car transporter vehicles permanently fitted to a trailer. Amend RS7 for consistency with O manual, add note 5
7	28/11/2025	Amend footnote to vehicle exemptions table in Mol (TSE IVA N2N3 03B 002). Move 'Rigid car transporter vehicles' out of STGO Exemptions in Table at MOI.

This page intentionally left blank

04 Rear Registration Plate Space

Application: All Vehicles

Method of Inspection	Required Standard											
<p>All vehicles must have a suitable place to mount a rear registration plate.</p> <p>Vehicles which are approved to Directive 70/222/EEC will not require an inspection to this section, providing the vehicle has not been modified.</p> <p>With an “IVA Test” plate of the required size placed onto the space provided, check that it is visible and that the whole of the shaded portion (yellow on DVSA supplied equipment) can be easily seen from a height of 1.5m from all points along a 21.5m line on the ground placed at 10.75m (centralised to the centre of the available rear reg. plate space) behind and parallel to the rear of the vehicle.</p> <p>Minor intrusions up to 5mm by mounting channels / retaining lugs into the shaded area will be permitted. These hold the plate in place along its edges but will still allow the registration mark to be displayed.</p> <p>Note 1: A plate hanging from the vehicle with no structure or support brackets behind it would be considered unacceptable.</p> <p>Note 2: Euro space dimensions taken from Directive 70/222/EEC.</p> <p>Note 3: Where it is impracticable to comply with the requirements due to body fitment, a second registration plate may be fitted to the opposite side of the vehicle to achieve compliance throughout the required viewing area</p>	<ol style="list-style-type: none"> 1. All vehicles must comply with one of the “options” listed in Table 1. 2. The space must permit the mounting of a plate in a position as close to vertical as possible taking into account the shape of the bodywork. 3. An external body surface or a purpose-designed mounting system securely attached to the vehicle must be provided to hold the plate in a fixed position (see Note 1). 4. The whole of the shaded portion of the IVA Test plate must be capable of being easily seen from every point along the test line (see Note 3). <p>Table 1</p> <table border="1" data-bbox="1137 884 2051 1058"> <thead> <tr> <th></th> <th></th> <th>Width</th> <th>Height</th> </tr> </thead> <tbody> <tr> <td rowspan="2">Euro space (see Note 2)</td> <td>Option 1</td> <td>520</td> <td>120</td> </tr> <tr> <td>Option 2</td> <td>340</td> <td>240</td> </tr> </tbody> </table>			Width	Height	Euro space (see Note 2)	Option 1	520	120	Option 2	340	240
		Width	Height									
Euro space (see Note 2)	Option 1	520	120									
	Option 2	340	240									

Rear Registration Plate Space 04

Record of Revision

Revision	Date	Description of Change
1	24/04/2009	
2	16/08/2010	Re – arrange order of notes
3	31/01/2010	Correct text misalignment in MOI
4	30/04/2012	Remove the term 'Yellow' from RS4 and reword note 3
5	29/10/2014	DVSA replaces VOSA
6	10/04/2018	Modify RS2 & replace Note 1, Add Note 3 Ref. Euro plate space
7	20/10/2023	New Note 3 referenced from RS4 (TSE IVA N2N3 04 001).

05 Steering Effort

Application: All Vehicles

Method of Inspection	Required Standard
<p>Ensure the vehicle as presented has satisfactory evidence of compliance to the required standard.</p> <p>Where modifications have taken place a lock-to-lock check must be carried out to check the system.</p> <p>The requirements according to the category of the base or incomplete vehicle based on maximum mass may apply.</p> <p>Note 1: A Mobile crane may be fitted with a crab steering system and if fitted it would not need approval.</p> <p>Note 2: STGO – Wide and Super-size CAT 2 and CAT 3 vehicles would not need approval and needs only to comply with RS 2.</p> <p>Note 3: For vehicles requiring an age-related IVA inspection only RS 2 applies.</p>	<ol style="list-style-type: none"> 1. The vehicle as presented must be accompanied by satisfactory evidence of compliance with the required standard for Steering Effort (see Notes 1, 2 & 3). 2. The steering system must operate smoothly from lock to lock and without undue stiffness. (see Note 3).

Record of Revision

Revision	Date	Description of Change
1	24/04/2009	
2	31/01/2011	Add Note 2 in reference to IVA on vehicles up to 25 years old.
3	29/10/2014	New Note 2 added (STGO), old Note 2 now Note 3.

06 Door Latches and Hinges

Application: All Vehicles

Method of Inspection	Required Standard
<p>All vehicles must provide safe access to and from the drivers and passenger’s cabin.</p> <p>Compliance may be demonstrated by:</p> <ul style="list-style-type: none"> • A vehicle approval or test report that relates to the vehicle in its finished condition, the vehicle must not display modifications that would affect the validity of the evidence, or • An inspection of the vehicle. <p>In the case of a Mobile crane exemption from one or more of the provisions is permissible where it can be demonstrated to the satisfaction of the Approval Authority that the special purpose of the vehicle makes it impossible to fully comply.</p> <p>Note 1: The dimension is increased to 700mm for an “off road” and STGO vehicles.</p> <p>Note 2: The dimension is increased to 100mm for an “off road” and STGO vehicles.</p> <p>Note 3: This variance does not apply between the cabin floor and the step immediately below it.</p> <p>Note 4: This is reduced to 200mm for an “off road” and STGO vehicles.</p> <p>Note 5: The outer edges of all steps must either be vertically in line, or the upper step(s) may be offset closer towards the vehicle than the lower step(s).</p>	<ol style="list-style-type: none"> 1. You must be able to open all driver and passenger doors. 2. All driver and passenger interior door handles/controls must be easily accessible from the adjacent seating positions. 3. All doors must be capable of being secured in the closed position. 4. The hinges of hinge-mounted doors (with the exception of folding doors), when fitted to the sides of the vehicles, must be fixed at the front edge of the doors in the direction of forward travel. In the case of double doors, these requirements apply to the door wing which opens first; it must be possible to secure the other wing of the door. <p>N2 vehicles with a maximum mass not exceeding 7,5 tonnes</p> <ol style="list-style-type: none"> 5. if the floor entrance to the passenger compartment of such vehicles is more than 600 mm above the ground, the vehicle must have one or more running boards or steps (see Note 1) 6. The running boards or steps must be constructed in such a way as to preclude the risk of slipping. <p>N2 vehicles with a maximum mass exceeding 7,5 tonnes and all N3 vehicles; <u>RS 7-28 applies</u></p> <p>Driver/passenger cabin access step measurements (refer to Figure 1);</p> <ol style="list-style-type: none"> 7. The first step must be not more than 600mm from the ground (A) (see Note 1).

Door Latches and Hinges 06

Method of Inspection	Required Standard
<p>Note 6: In the case of “off road” vehicles or, if this is necessary for reasons relating to construction & use or STGO.</p> <p>Note 7: The steering wheel may be considered as a handhold and as such does not need to meet any dimensional requirements.</p> <p>Note 8: For “off-road” and STGO vehicles, the dimension may be increased to 1950 mm. If the floor of the driver's compartment has a height from the ground greater than “N,” the handrail or handhold or equivalent holding device must terminate at the floor of the cab.</p>	<ol style="list-style-type: none"> 8. The vertical distance (B) between upper surfaces of the steps must not be more than 400mm apart. 9. The step height (S) must be a minimum of 120mm. 10. The vertical distance (B) between any two subsequent steps must not vary by more than 50mm (see Notes 2 & 3). 11. The depth of the step upper surface must be a minimum of 80mm (D). 12. The step must permit a user's foot to safely use the step and must have a minimum of 150mm free space (including step upper surface depth) (E). 13. The width of the upper surface of a step (except for the lowest step) must be a minimum of 300mm. (F) (see Note 4). 14. The width of the upper surface of the lowest step must be a minimum of 200mm (G). 15. There must not be any transversal offset between steps (H) (see Note 5). 16. There must be a minimum of 200mm longitudinal overlap between two subsequent steps in the same flight, or between the uppermost step and the cabin floor (J). <p>In addition, the following minimum geometrical specifications for the steps must be met:</p> <ol style="list-style-type: none"> 17. The lowest step may be designated as a rung and in this instance, the rung depth (R) must be a minimum of 20mm (see Note 6). 18. Rungs must not be of a round cross section.

Door Latches and Hinges 06

Method of Inspection	Required Standard
	<p>19. While descending from the driver's / passenger compartment the position of the uppermost step must be easily found.</p> <p>20. The upper surface of the steps must be non-slip. In addition, steps exposed to the weather and the dirt during driving shall have adequate run-off (draining surface).</p> <p>Access to handholds to the driver's compartment (see Note 7 and Figure 1)</p> <p>21. One or more suitable handrails, handholds or other equivalent holding devices must be provided for any access normally used to access the driver's / passenger compartment.</p> <p>22. The handrail(s) or handholds or equivalent holding devices must be positioned in such a way that they can be easily grasped and do not obstruct access.</p> <p>23. Handrails, handholds, or equivalent holding devices must not have more than 100mm discontinuity, to allow for items such as intermediate supports/fixings.</p> <p>24. In the case of access with more than two steps the handrails, handholds or equivalent holding devices must be located so that a person may support themselves at the same time at three points (with two hands and one foot or with two feet and one hand).</p> <p>25. Except in the case of a stairway, the design and positioning of the handrails, handholds and equivalent holding devices must be such that operators are encouraged to descend facing the cab.</p> <p>26. The height (N) of the lower edge of at least one handrail or handhold or equivalent holding device, measured from the ground with the vehicle in running order, shall not be more than 1850 mm (see Note 8).</p>

Door Latches and Hinges 06

Method of Inspection	Required Standard
	<p>27. The minimum distance of the upper edge of the handrail(s), handholds, or equivalent holding devices from the floor of the driver's compartment (P) must be:</p> <ul style="list-style-type: none"> a. handrail(s) or handholds or equivalent holding devices (U) 650 mm, b. handrail(s) or handholds or equivalent holding devices (V) 550 mm. <p>28. The following geometrical specifications must be met:</p> <ul style="list-style-type: none"> a. gripping diameter (K): 16 mm minimum 38 mm maximum, b. length (M): 150 mm minimum, c. clearance to vehicle components (L): 40 mm minimum with open door.

Figure 1

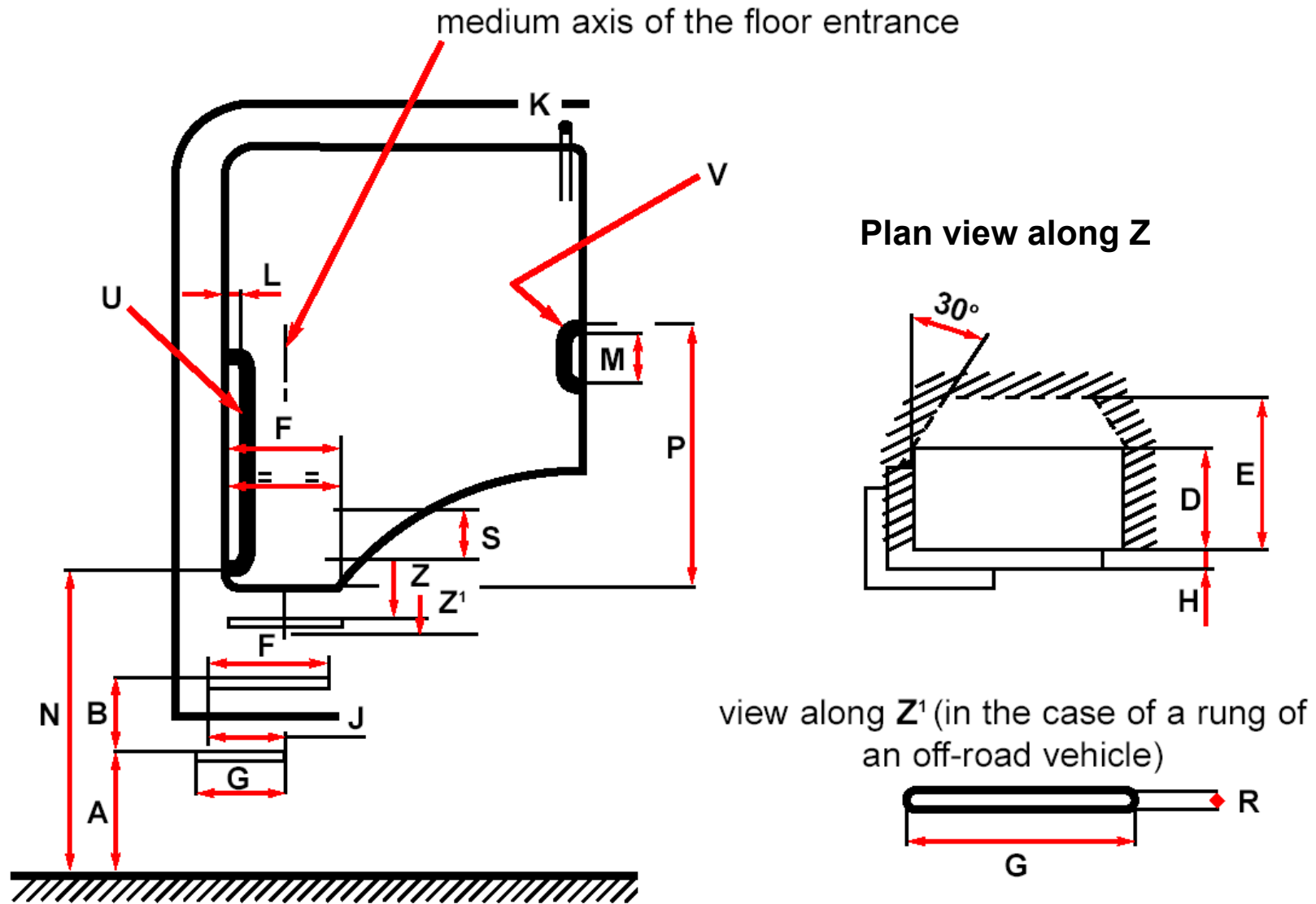

Door Latches and Hinges 06

Record of Revision

Revision	Date	Description of Change
1	24/04/2009	
2	16/08/2010	Remove notes from standards, link notes to correct RS and re-arrange order of RS
3	31/01/2011	Add new RS 1 and renumber other standards
4	29/10/2012	Insert new Note 5, align with RS15 and renumber following notes
5	29/10/2014	Reference to STGO added to Notes 1, 2, 4, 6 & 8, step height (S) clarified
6	01/09/2015	Clarification of RS

07 Audible Warning

Application: All Vehicles

Method of Inspection	Required Standard
<p>Ensure that the vehicle is fitted with a horn which when operated emits a continuous uniform sound that is capable of giving audible warning of the approach or position of the vehicle to which it is fitted.</p> <p>Additional panic alarm devices are permitted.</p> <p>Note 1: For the purposes of this item "horn" means an audible warning device not being a bell, gong, or siren.</p> <p>Note 2: In the case of an Armoured vehicle: Exemption from RS 3 & 4 are permissible where it can be demonstrated to the satisfaction of the Approval Authority that the special purpose of the vehicle makes it impossible to fully comply.</p>	<ol style="list-style-type: none"> 1. The vehicle must be fitted with a horn (see Note 1). 2. The horn must be securely attached to the vehicle. 3. When operated the horn must emit a continuous uniform sound (see Note 2). 4. The horn as installed, must give an equivalent level of warning to other road users as that of an equivalent N2/N3 EC Type Approved vehicle (see Note 2).

Record of Revision

Revision	Date	Description of Change
1	24/04/2009	
2	29/10/2012	Clarify Note 2

08 Indirect Vision

Application: All Vehicles

Method of Inspection	Required Standard
<p>The vehicle must be fitted with appropriate devices for indirect vision that enable the driver an adequate view to the rear.</p> <p>Alternatively, vehicles manufactured after 1st April 2016 may be equipped with a camera monitor system (CMS) that has full approval to UNECE Regulation 46.04. These systems generally replace the Class II and Class IV mirrors.</p> <p>Compliance can be demonstrated by component approval or the presence of approval marks (for unmodified vehicle cabs). In the case of an Armoured vehicle, exemption from one or more of the provisions is permitted where it can be demonstrated to the satisfaction of the Approval Authority that the special purpose of the vehicle makes it impossible to fully comply.</p> <p>Note 1: For Age-related IVA please refer to the obligatory mirrors shown in Table 2.</p> <p>Note 2: Mirror security should be such that wind deflection when the vehicle is driven at normal road speeds will not cause the field of view to change. It should also be mounted so that the mirror cannot vibrate and cause the driver to misinterpret the image.</p> <p>Note 3: Where a valid approval or test report is available which covers the vehicle in its finished state, a field of view check is not required.</p> <p>Note 4: For N2 ≤7500kg vehicles – compulsory only if a Class V mirror can be fitted.</p>	<p>Installation check for mirrors only</p> <ol style="list-style-type: none"> 1. The vehicle must have all the obligatory mirrors fitted (see Table 1 & Note 1). 2. All mirrors must be securely attached to the vehicle (see Note 2). 3. All obligatory mirrors must bear an acceptable European approval mark ('E' or 'e'). 4. All obligatory mirrors must bear the appropriate class type (see Table 1 and Note 1). 5. All mirrors must be adjustable. 6. All obligatory mirrors must meet the field of view requirements (see Note 3 and Figure 1 or 2). 7. If a class V or VI mirror is mounted then regardless of their position after adjustment, no part of these mirrors or their holders must be less than 2m from the ground when the vehicle is unladen. (see Note 4). 8. Where the lower edge of an exterior mirror is less than 2m above the ground this mirror must not project more than 250mm beyond the overall width of the vehicle measured without mirrors. <p>Camera Monitor Systems</p> <ol style="list-style-type: none"> 9. Camera Monitor System installations must be accompanied by acceptable evidence of approval to UNECE Regulation 46.04

Indirect Vision 08

Method of Inspection	Required Standard										
<p>Note 5: These mirrors are not required to be mounted on vehicles where the cab height is such as to prevent compliance with the 2 metre height requirement and are only required on “Forward control vehicles” (See Glossary of Terms).</p>	<p>Table 1</p> <table border="1"> <thead> <tr> <th data-bbox="1077 268 1547 304">Class of Mirror</th> <th data-bbox="1547 268 2098 304">Obligatory Fitment to Vehicle</th> </tr> </thead> <tbody> <tr> <td data-bbox="1077 304 1547 341">Side Exterior (Class II)</td> <td data-bbox="1547 304 2098 341">Offside and nearside</td> </tr> <tr> <td data-bbox="1077 341 1547 378">Wide Angle (Class IV)</td> <td data-bbox="1547 341 2098 378">Offside and nearside (see Note 4)</td> </tr> <tr> <td data-bbox="1077 378 1547 414">Side Close proximity (Class V)</td> <td data-bbox="1547 378 2098 414">Nearside (offside if LHD) (see Note 5)</td> </tr> <tr> <td data-bbox="1077 414 1547 451">Front (Class VI)</td> <td data-bbox="1547 414 2098 451">Front (7501kgs or more) (see Note 5)</td> </tr> </tbody> </table>	Class of Mirror	Obligatory Fitment to Vehicle	Side Exterior (Class II)	Offside and nearside	Wide Angle (Class IV)	Offside and nearside (see Note 4)	Side Close proximity (Class V)	Nearside (offside if LHD) (see Note 5)	Front (Class VI)	Front (7501kgs or more) (see Note 5)
Class of Mirror	Obligatory Fitment to Vehicle										
Side Exterior (Class II)	Offside and nearside										
Wide Angle (Class IV)	Offside and nearside (see Note 4)										
Side Close proximity (Class V)	Nearside (offside if LHD) (see Note 5)										
Front (Class VI)	Front (7501kgs or more) (see Note 5)										

Table 2

Obligatory Requirements for Age-related IVA								
	Date first used	External		Additional External				
		Class II		Class IV		Class V		Class VI
		Offside	Nearside	Offside	Nearside	Offside	Nearside	Front
N2	First used on or after 01/04/1985	✓	✓					
N3	First used on or after 01/04/1985 but before 01/10/1988	✓	✓					
N3	First used after 01/10/1988	✓	✓		✓ See Note 1 below		✓	
N2 ≤ 7500kg	First used on or after 01/01/2000	✓	✓	✓ See Note 2 below	✓ See Note 2 below		✓ See Note 2 below	
N2 > 7500kg / N3				✓	✓			
N2 ≤ 7500kg	First used on or after 26/01/2007	✓	✓	✓ See Note 2 below	✓ See Note 2 below		✓	✓ See Note 3 below
N2 > 7500kg / N3				✓	✓			
<p>Note 1: Only required if the vehicle is articulated</p> <p>Note 2: Only required where the cab height permits the close-proximity mirror to be fitted at least 2m above the ground</p> <p>Note 3: Only required if the vehicle is 7501kgs or more</p>								

Figure 1

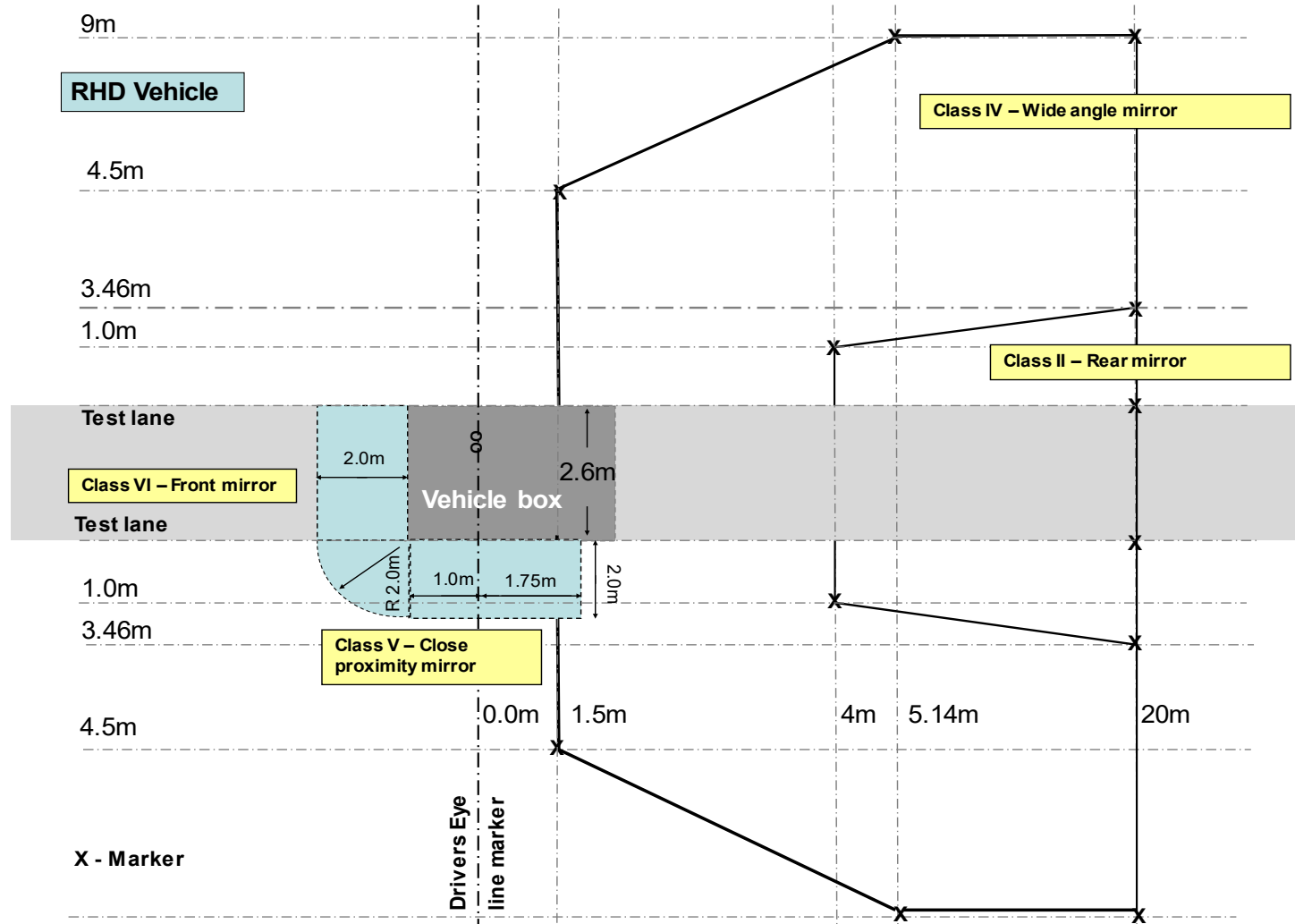
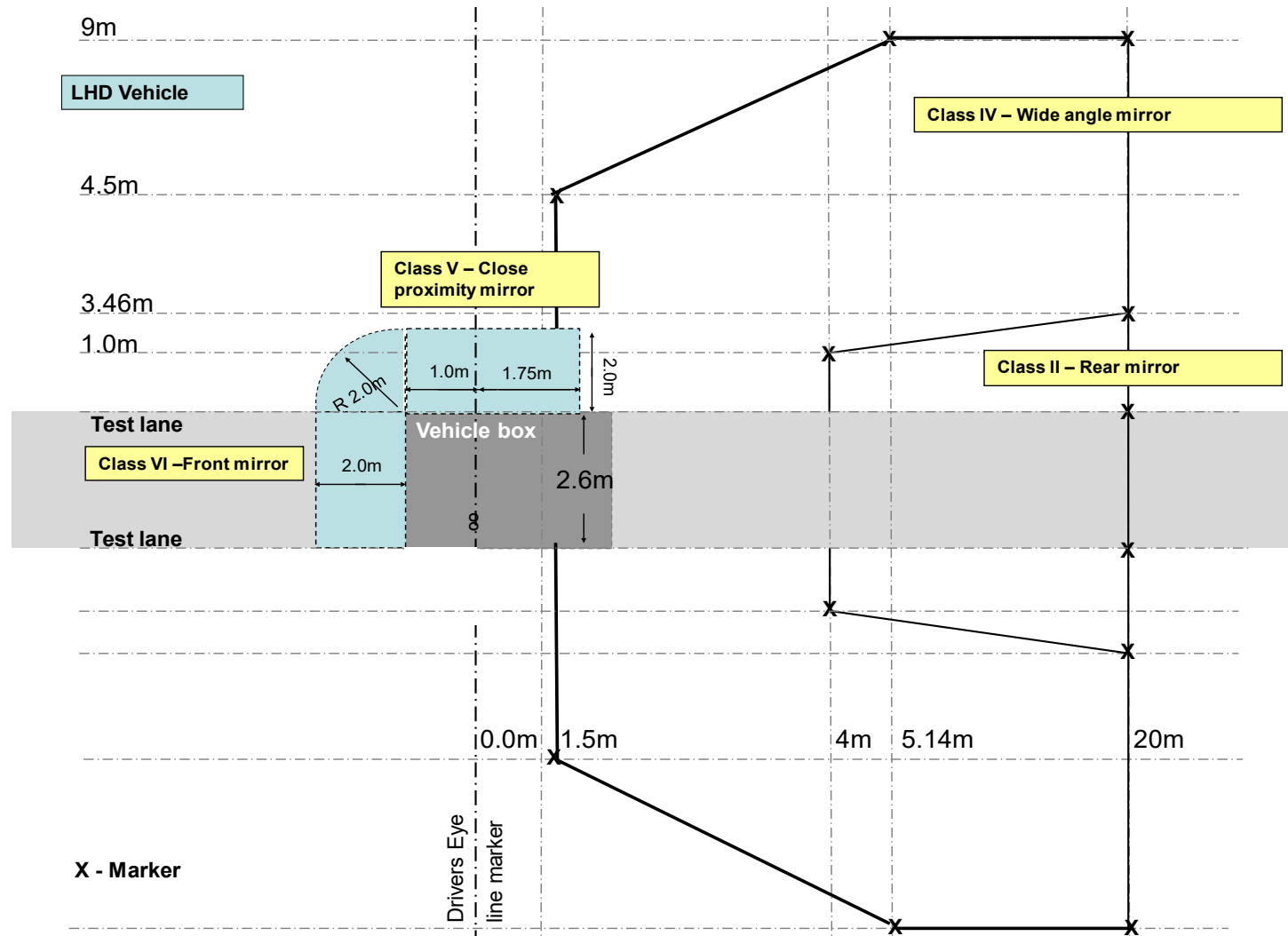

Figure 2



Record of Revision

Revision	Date	Description of Change
1	24/04/2009	
2	16/08/2010	Add note 3 and link to RS7
3	31/07/2011	Add Age-related mirror requirements
4	30/04/2012	Add more note references to ARIVA mirror requirements
5	03/02/2014	Insert link from wide angle mirrors to note 3 in Table 1
6	29/10/2014	Table 2 notes referenced in table, N3 (post 01/10/1988) Class IV requirement corrected
7	10/04/2018	Reorder notes & Amendment to Note 4 (forward control vehicles)
8	01/07/2018	Delete Ref. to 2003/97 in figures 1 & 2
9	01/09/2020	Amend Mol and RS to cover CMS (RV(A)R 2020).
10	20/10/2023	New RS 8 added, old RS8 renumbered (TSE IVA N2N3 048 005) Table 2 notes referenced, N2/N3 (post 26/01/2007). Figure 1 & 2 revision including correction of locations for Class V close proximity mirrors.

09 Braking

Application: All Vehicles

Method of Inspection	Required Standard
<p>Ensure that the vehicle as presented has satisfactory evidence of compliance to the required standard.</p> <p>In the case of a Mobile crane with more than 4 axles derogations are permitted provided that:</p> <ul style="list-style-type: none"> a) they are justified by the particular construction; and b) all the braking performances relating to parking, service and secondary braking are fulfilled. Documentary evidence is required from the approval authority. <p>Note 1: Vehicles subject to both P&T and STGO (dual use) will require evidence of compliance for P&T weights, and evidence of compliance for the higher weights of STGO. The latter should comprise calculations, (verified by a technical service) test track work is not requested.</p> <p>Note 2: Vehicles solely for STGO use will be required to provide evidence of compliance to the requirements via documentary evidence. This should comprise calculations, (verified by a technical service) test track work is not requested.</p>	<ol style="list-style-type: none"> 1. The vehicle as presented must be accompanied by satisfactory evidence of compliance with the required standard for "Braking." (see Notes 1 & 2)

Record of Revision

Revision	Date	Description of Change
1	24/04/2009	
2	29/10/2014	Notes 1 & 2 added to Mol
3	01/09/2015	Amend text for mobile cranes
4	10/04/2018	Amend Notes 1 & 2 and Reference the RS to both

10 Electromagnetic Compatibility

Application: All Vehicles

Method of Inspection	Required Standard
<p>Ensure the vehicle has satisfactory evidence of compliance to the required standard and has not been modified such to invalidate the approval.</p> <p>Note 1: STGO – Abnormal Indivisible Load Vehicles (GTW of at least 120,000kg) where due to its special build No base vehicle approval is available, will only require a declaration from the manufacturer for the equipment fitted.</p> <p>Note 2: This only applies to equipment that is likely to be used when the vehicle is being driven.</p>	<ol style="list-style-type: none"> 1. The vehicle as presented must be accompanied by satisfactory evidence of compliance with the required standard for “EMC.” (see Note 1). 2. Where any additional equipment has been installed, a declaration supplied by the Manufacturer / applicant, confirming compliance of the additional items must be presented (see Note 2).

Record of Revision

Revision	Date	Description of Change
1	24/04/2009	
2	31/07/2011	Add Note 1 and link to RS2
3	29/10/2014	New Note 2 added
4	01/09/2015	RS 1 Referenced to note 2
5	10/04/2018	Amend Notes

13 Anti – Theft / Immobiliser / Alarm

Application: All Vehicles (Optional Fitment)

Method of Inspection	Required Standard
<p>If the vehicle is fitted with a mechanical anti-theft device, an electronic immobiliser, or an alarm system (including panic alarm) The system or systems must comply with this section.</p> <p>Note 1: A “Category 1” installation refers to an immobiliser and an alarm. “Category 2” installation refers to an immobiliser only.</p> <p>Ensure that the vehicle is accompanied by documentary evidence of compliance for a category 1 or 2 installation as appropriate.</p> <p>Evidence of compliance must be one of the following:</p> <ul style="list-style-type: none"> • Documentary evidence from a test laboratory • Documentary evidence from the chassis manufacturer • An original certificate of installation from a Mobile Electronics and Security Federation (MESF) accredited installer <p>Note 2: An optional panic alarm not forming part of an alarm system is not required to meet RS4.</p>	<ol style="list-style-type: none"> 1. Where an anti-theft device incorporates a mechanical part that acts upon a system used to control the vehicle; <ol style="list-style-type: none"> a. It must deactivate before the engine can be started b. It must be deactivated while the engine is running c. It must have an actuation which is a distinct and separate function from that of stopping the engine d. It must not operate on any part of the braking system 2. If fitted to the Vehicle, an Immobiliser must be accompanied by evidence of compliance (see Note 1). 3. If fitted to the Vehicle, an Alarm must be accompanied by evidence of compliance (see Note 1). 4. If fitted to the Vehicle, a Panic Alarm must be accompanied by evidence of compliance (see Notes 1 & 2).

Anti – Theft / Immobiliser / Alarm 13

Record of Revision

Revision	Date	Description of Change
1	24/04/2009	
2	16/08/2010	Add note 3 and link to RS4
3	31/01/2011	Add Thatcham Recognised Installer installation report to list of acceptable evidence
4	30/04/2012	Remove VSIB from the list of acceptable evidence
5	10/04/2018	Amend MOI & Note 2
6	01/09/2020	Removal of Thatcham Recognised Installer

15 Seat Strength

Application: All Vehicles

Method of Inspection	Required Standard
<p>The requirements of this section can be deemed to be met where the vehicle is presented with evidence of :-</p> <ul style="list-style-type: none"> • An approval to the requirements of Directive 74/408 as last amended by 2005/39/EC or the requirements of UNECE Regulation 17.06 or 80.01, or • a test report to the technical provisions of the Directives/Regulations quoted above, and • subject to a random check that the documentation matches the vehicle presented, including seat type. <p>Note 1: This inspection does not apply to any seating intended solely for use while the vehicle is stationary, and any such seats must be clearly identified to users by means of a pictogram or a sign with appropriate text.</p> <p>Note 2: In respect of a seat that comprises of a “lift-out” backrest and/or squab it will be considered secure providing, when in the operational position, it is located such that there is no possibility of accidental lateral or longitudinal movement within the vehicle.</p> <p>Note 3: On a seat to which a seat belt is mounted (integral seat belt) consideration must be given to the seat mounting as they are now considered to be seat belt anchorages. The Standards, and guidance on the types of construction acceptable for this type of seat are found in section 19 (Seat Belt Anchorages).</p> <p>Note 4: A seat/seat back INERTIA locking device is acceptable, i.e., a device that operates during the deceleration of the vehicle.</p>	<ol style="list-style-type: none"> 1. All seats must be adequate in strength and securely mounted to a load bearing part of the structure or have adequate support to spread the load of the seat mounting if attached to a non-metallic floor pan separate from the chassis (see Notes 1, 2, & 3). 2. Where seats incorporate seat belt anchorages the seat must be approved to at least the category of vehicle to which they are fitted. 3. All seat mountings must be of adequate strength to support the loads likely to be imposed (see Notes 1 & 3). 4. Each moveable seat, seat back adjustment and seat displacement system must incorporate an automatic locking system which operates in all positions provided for normal use (see Notes 1 & 4). 5. All seats which can be tipped forward or have fold-down backs must lock automatically in the normal position and if seats for adults are fitted behind, then the unlocking control must be easily accessible from that position (see Notes 1 & 4). 6. Where seats are intended for use only when the vehicle is not being driven on public roads, the seats must be accompanied by a pictogram or sign clearly indicating that the seat is not to be used whilst the vehicle is in motion.

Record of Revision

Revision	Date	Description of Change
1	24/04/2009	
2	16/08/2010	Reword MOI
3	10/04/2018	Section rewrite & align with M manual
4	20/10/2023	Corrected wording in Note 2

17 Speedometer and Reverse Gear

Application: All Vehicles having a maximum speed exceeding 25mph

Method of Inspection	Required Standard
<p>A vehicle must indicate an accurate speed to the driver at all times and the vehicle must be capable of travelling in a rearward direction under its own power.</p> <p>A Speedometer may be digital or a dial instrument.</p> <p>Note 1: Vehicles using age-related IVA manufactured before May 2006 can use an analogue tachograph to fulfil this function.</p> <p>Note 2; STGO - Abnormal Indivisible Load Vehicles (GTW of at least 120,000kg) only requires the speedometer to be marked in mph.</p> <p>Note 3: Where the accuracy of the device is in question, it will be necessary for the applicant to provide compliance.</p> <p>Note 4: Imperial (mph) markings are not required on a tachograph dial face.</p> <p>Note 5: The first marked increment may be at 0 mph but must not exceed 20 mph.</p> <p>Note 6: Vehicle maximum design speed (without the use of a speed limiting device) shall be in the form of vehicle specific documentary evidence from the vehicle manufacturer.</p> <p>Note 7: "Reverse Gear" is a device used to propel the vehicle in a rearward direction under its own power. This does not have to be in the gearbox, it may be a separate component i.e., electric motor.</p>	<ol style="list-style-type: none"> 1. The vehicle must be fitted with a Speedometer capable of accurately indicating the speed of the vehicle (see Notes 1, 2 & 3). 2. The speedometer must be capable of being read at all times of the day or night. 3. Imperial (mph) and metric (km/h) units must be permanently marked on the face of a dial instrument (see Notes 2 & 4). 4. The "rest" position for the needle of a dial type must lie either on or below the first marked increment (see Note 5). 5. A speedometer must be capable of indicating the vehicle speed in miles per hour (mph) and kilometres per hour (km/h) at uniform intervals not exceeding 20mph for all speeds up to the maximum design speed of the vehicle. (see Note 6). <p>Reverse gear</p> <ol style="list-style-type: none"> 6. The vehicle must have a reverse gear, which can be selected from the driving position and operates (see Note 7).

Speedometer and Reverse Gear 17

Record of Revision

Revision	Date	Description of Change
1	24/04/2009	
2	16/08/2010	Reword Note 2, removed and renumbered standards
3	03/02/2014	Insert text in note 1, new note 2 and new RS3, interchange previous RS3 and 4.
4	29/10/2014	New note 2 (STGO), old notes 2 – 4 now 3 – 5
5	01/09/2015	Delete analogue tachometer (Except age-related) and amend required standards
6	10/04/2018	MOI notes updated.
7	01/09/2020	Title above RS6 corrected, RS3 clarified, further MOI clarification.

18 Statutory Plates

Application: All Vehicles

Method of Inspection	Required Standard
<p>All vehicles must be provided with a manufacturer’s plate and inscriptions described in this section.</p> <p>Legislation places no restriction on the material from which the plate is made. The purpose of the plate is to impart information rather than to act as a proof of identity.</p> <p>Check that the manufacturer’s plate (in the case of a multistage build, one for each stage) complies with the Required Standards. It would be helpful if separate plates are fitted in close proximity to each other, but this is not mandatory for vehicles covered by this manual.</p> <p>Visually check that the characters used for the Manufacturers Plate and Vehicle Identification Number (VIN) complies to the required standards.</p> <p>Where the vehicle is subject to a multistage build, a plate is required on completion of each stage as appropriate, every plate fitted must display the same VIN as displayed on the chassis, the weight information is only necessary on the chassis manufacturer’s plate or on a converters plate if they have altered those weights with any modification.</p> <p>The manufacturer may give additional information. The approval number and build stage number may be listed below the manufacturers name, and the number of axles may be listed underneath the VIN number. Any other information must be outside a clearly marked rectangle which shall enclose only the listed information.</p>	<p><u>Manufacturers VIN Plate</u></p> <ol style="list-style-type: none"> 1. The vehicle must be fitted with a manufacturer’s plate, in a conspicuous and readily accessible position. 2. A manufacturer’s plate must be fitted for each stage of a multistage build. (see Note 1) 3. The manufacturer’s plate(s) must be made of a durable material. 4. All plate(s) must be indelibly marked with the Vehicle Identification Number (VIN) which matches the number marked into the vehicle structure (see Note 2). 5. The manufacturer’s plate(s) must be securely attached to a part of the vehicle that will not be replaced through normal use (see Note 3). 6. The manufacturer’s plate(s) must show the required information, in the correct order inside a clearly marked rectangle. (see Annex 1). 7. The Vehicle Identification number on the manufacturer’s plate must be marked in characters at least 4mm high. 8. The characters on the manufacturer’s plate (with the exception of the Vehicle Identification Number) must be at least 2mm high.

Statutory Plates 18

Method of Inspection	Required Standard
<p>The identification number of the base vehicle (VIN) prescribed by Directive 76/114/EEC shall be retained during all the subsequent stages of the type-approval process to ensure the 'traceability' of the process.</p> <p>However, at the final stage of completion, the manufacturer concerned by this stage may replace, in agreement with the approval authority, the first and second sections of the vehicle identification number with their own vehicle manufacturer code and the vehicle identification code if, and only if, the vehicle has to be registered under his own trade name. In such a case, the complete vehicle identification number of the base vehicle must not be deleted.</p> <p>All vehicles must have a vehicle identification number marked onto the chassis by hammering, stamping or similar so that the vehicle can be clearly identified.</p> <p>Note 1: A separate manufacturer's build plate will not be required for a vehicle subject to an age-related IVA inspection unless a structural/chassis modification has been carried out since the original build e.g., the installation of an additional axle.</p> <p>Note 2: For markings to be considered 'indelible' they should be unlikely to become disfigured or obliterated during the life of the trailer. Whilst stamping or engraving is preferable it is possible to accept a printed or painted plate providing it has been treated in such a way that it is most unlikely that essential information would be obliterated or defaced during the normal life of the vehicle.</p> <p>Note 3: 'Securely attached' means screwed, bolted, riveted, or otherwise fixed such that it is not likely to become displaced during the life of the vehicle.</p>	<p><u>Permanent VIN Number</u></p> <ol style="list-style-type: none"> 9. The VIN must be marked on the chassis, frame, or other similar structure on the right hand side of the vehicle (viewed from the rear). 10. The VIN must be placed in a clearly visible and accessible position by a method such as hammering or stamping so that it cannot be obliterated or deteriorate. 11. The VIN number must consist of 17 digits with the information shown in a single line (see Notes 4 & 5). 12. Capital letters and numerals must be used for the VIN. 13. There must not be any gaps between the characters for the VIN or unique vehicle identifier number shown on the manufacturer's plate or stamped into the vehicle (see Note 5). 14. The characters used for the VIN number stamped into the chassis, frame or other similar structure must be at least 7mm high. 15. Use of the letter I, the letter O, the letter Q, dashes, asterisks, and other special signs are not permitted. <p><u>Where the VIN has been changed in agreement with the Approval Authority</u></p> <ol style="list-style-type: none"> 16. Evidence of the agreement with the approval authority must be provided. 17. The original complete vehicle identification number of the base vehicle must be present on the chassis. 18. The complete new VIN must be stamped on the chassis as near as possible to the original VIN.

Method of Inspection	Required Standard																																										
<p>Note 4: As an exception for technical reasons, it may also be marked on two lines. However, in this case no section may be divided between the two lines. The beginning and end of each line must be indicated by a symbol which is neither an Arabic numeral nor a roman capital letter, and which cannot be confused with either. (First section would be 3 characters in length, second section would be 6 characters in length, and the last section would be 8 characters in length).</p> <p>Note 5: The spacing of characters must be such that no additional characters could be added at a later date.</p> <p>Note 6: There is no specific format for the special type's plate. The diagram shown opposite is purely an example. It is important to ensure the presence of all relevant information.</p> <p>Note 7: There is no requirement for a plate on a vehicle defined as engineering plant. A plate (as opposed to a sign) is only required for Category 2 or 3 Abnormal Indivisible Load Vehicles, mobile cranes, and road recovery vehicles.</p>	<p>19. The last eight characters of the new V.I.N. must be identical to the last eight characters of the base vehicle V.I.N.</p> <p>Special Types Plate (see Notes 6 & 7)</p> <p>20. The vehicle must be fitted with a "Special Types" plate that is securely fixed to the vehicle in a conspicuous and readily accessible position.</p> <p>21. It must contain the heading "SPECIAL TYPES USE" in letters not less than 4mm high.</p> <p>22. It must be indelibly marked, in letters and figures not less than 4mm high, with the maximum weights (in kg or tonnes) at which, in the opinion of the manufacturer, the vehicle may be used legally in the UK when travelling on roads at or below the speed in question, as per the table below, (with the speeds and number of axles as applicable):</p> <p style="text-align: center;">SPECIAL TYPES USE</p> <table border="1" data-bbox="1010 807 2107 1088"> <thead> <tr> <th></th> <th>Axle 1</th> <th>Axle 2</th> <th>Axle 3</th> <th>Axle 4</th> <th>Max gross weight</th> <th>Max train weight</th> </tr> </thead> <tbody> <tr> <td>20 mph</td> <td></td> <td></td> <td></td> <td></td> <td></td> <td></td> </tr> <tr> <td>25 mph</td> <td></td> <td></td> <td></td> <td></td> <td></td> <td></td> </tr> <tr> <td>30 mph</td> <td></td> <td></td> <td></td> <td></td> <td></td> <td></td> </tr> <tr> <td>35 mph</td> <td></td> <td></td> <td></td> <td></td> <td></td> <td></td> </tr> <tr> <td>40 mph</td> <td></td> <td></td> <td></td> <td></td> <td></td> <td></td> </tr> </tbody> </table>		Axle 1	Axle 2	Axle 3	Axle 4	Max gross weight	Max train weight	20 mph							25 mph							30 mph							35 mph							40 mph						
	Axle 1	Axle 2	Axle 3	Axle 4	Max gross weight	Max train weight																																					
20 mph																																											
25 mph																																											
30 mph																																											
35 mph																																											
40 mph																																											

Annex 1

Manufacturers Plate (see note 1, 2, 3 & 4)

DVSA MOTORS INC	
e11*2007/46*0291*02	
SA9A3ACTBE1234567	
22000Kg	25500Kg
23500kg	29000kg
7000Kg	7500Kg
8000Kg	9000Kg
8000Kg	9000Kg

Name of Manufacturer

Approval number and/or Build Stage number (If applicable)

Vehicle Identification Number (VIN)

Maximum permitted laden mass of vehicle

Maximum permitted laden mass for the combination where the vehicle is used for towing (see **Note 5** below)

Maximum permitted laden road mass for each axle, listed in order from front to rear

Note 1: Where the vehicle is subject to a multistage build, a plate is required on completion of each stage as appropriate, every plate fitted must display the same VIN as displayed on the chassis, the weight information is only necessary on the chassis manufacturer's plate or on a converters plate if they have altered those weights with any modification.

Note 2: For markings to be considered 'indelible' they should be unlikely to become disfigured or obliterated during the life of the vehicle. Whilst stamping or engraving is preferable it is possible to accept a printed or painted plate providing it has been treated in such a way that it is most unlikely that essential information would be obliterated or defaced during the normal life of the vehicle.

Note 3: The spacing of characters must be such that no additional characters could be added at a later date.

Note 4: If any of the technically permissible masses are higher than the masses permitted in GB and NI for a vehicle or axle (see Annex 1 for details of the maximum masses permitted in GB and NI), then there should be 2 columns for masses - in the left hand column the maximum permitted mass in GB/NI, and in the right hand column, the technically permissible mass.

This does not apply to a vehicle issued with a Plating certificate under the Goods Vehicles (Plating and Testing) Regulations 1988 where only one column, giving the technically permissible masses, is permitted. (See Section 48 Masses and Dimensions for requirements for a plating certificate).

Note 5: Only required to be displayed on applicable vehicles, i.e., designed to allow towing.

Record of Revision

Revision	Date	Description of Change
6	29/10/2012	Insert new Note 1 and renumber following Notes.
7	03/02/2014	Insert marked rectangle in RS6 and remove manufacturer from RS10.
8	29/10/2014	DVSA replaces VOSA, new RS19, 20 & 21 relating to Special Types Plate.
9	23/01/2015	Add note 8 relating to special types plate format and amendments to Annex 1.
10	01/09/2015	Addition of Note 9.
11	10/04/2018	Rewrite Section, remove weights table.
12	01/09/2020	Clarify STGO plate and multistage plate requirements, add Note 7.
13	28/11/2025	Opening paragraph at MoI revised to include details of plate and inscription attachment.
14	11/05/2026	MOI opening paragraph wording revised.

This page intentionally left blank

19 Seat Belt Anchorages

Application: All Vehicles (required to be fitted with seatbelts- see **Section 31**)

Method of Inspection	Required Standard
<p>Application limited to seats designated for normal use when the vehicle is travelling on the road. Seats which are not designated for use when the vehicle is travelling on the road shall be clearly identified to users either by means of a pictogram or a sign with an appropriate text. See Section 31, RS 03.</p> <p>Ensure each seating position is fitted with the required number of anchorage points. Assess the anchorage positioning, their strength, and that of the surrounding vehicle structure.</p> <p>Note 1: Where the vehicle has two driving positions both must meet the minimum anchorage requirements, and the second seat satisfies the requirement for the “foremost outboard “passenger seat”.</p> <p>Note 2: The front centre seat will require 3 anchorages and a 3 point belt where the windscreen is located:</p> <ul style="list-style-type: none"> a) in the case of a fixed (non-sliding) seat, within 840mm. of the seat reference point, or; b) in the case of a sliding seat, within 840mm. of the seat reference point when the seat is 127mm forward of its rearmost position (see Annex 3). <p>Note 3: Seats require a minimum of 2 point anchorage if they are exposed, i.e., if there is no screen in front of a seat. The screen being no more than 1.3m in front of the H point wide enough to be at least 200mm either side of the H point and high enough to reach 400mm above the H point. The surface area of the screen must be at least 800cm². A screen or seat forming a screen must meet the following conditions:</p>	<ol style="list-style-type: none"> 1. The drivers seating position must have a minimum of 2 anchorages (see Note 1). 2. The foremost outboard passenger seating position must have a minimum of 2 anchorages. 3. A front centre seating position must have a minimum of: <ul style="list-style-type: none"> a. 2 anchorages or b. 3 anchorages (see Note 2) 4. Rear seating positions must have a minimum of 2 anchorages if required to be fitted with seat belts. (see Note 3 and Annex 1 in Section 31). 5. The seat belt anchorage must be correctly located so to ensure the belt will sit correctly on the wearer. 6. The anchorage and surrounding structure must be of adequate strength to withstand the load likely to be imposed by the torso in the event of a vehicle frontal impact (Annex 1). 7. Those seats which are not intended for use when the vehicle is driven on a public road must be accompanied with a pictogram or sign clearly indicating that the seat is not to be used whilst the vehicle is in motion (see Note 4).

Method of Inspection	Required Standard
<p>a) The surface must be of suitable strength and showing no discontinuities such that, if a sphere of 165 mm diameter is geometrically projected in a longitudinal horizontal direction through any point of the space defined above and through the centre of the sphere, nowhere in the protective screen is there any aperture through which the geometrical projection of the sphere could be passed.</p> <p>b) A seat is considered to be an 'exposed seating position' if the protective screens within the space defined above have a combined surface area of less than 800 cm².</p> <p>Note 4: This applies to vehicle types such as mobile banks, incident support units or similar where seating is provided in the rear 'load carrying' space and intended for use only when the vehicle is stationary.</p>	

Annex 1

Strength of seat belt anchorages

Seat belt anchorages must comply with the strength requirements for N2 / N3 vehicles in Directive 76/115/EEC

This can be demonstrated in one of the following ways:

1. Evidence of type approval
2. Documentary evidence of testing to the Directive standard
3. Comparison with a type approved vehicle
4. Visual assessment

1. Evidence of type approval

Suitable evidence of type approval will be accepted. If the seat has integral anchorage points this must cover the specific seat make and type and it's mounting to structure.

2. Documentary evidence of testing to the Directive standard.

Suitable documentary proof will be accepted. If the seat has integral anchorage points this must cover the specific seat make and type and it's mounting to structure.

3. Comparison with a type approved vehicle

Evidence that the vehicle is of identical structure to a vehicle which has been demonstrated to comply with the requirements, or which is type approved may be used to confirm compliance. If the seat has integral anchorage points the comparison must have the same seat type and floor mounting structure.

4. Visual Assessment

In the absence of documentary evidence, the vehicle may comply with the visual inspection requirements in Annex 2.

Annex 2

Seat Belt Anchorages Strength Assessment - General

In a severe accident, the seated occupant can exert huge loads upon their seatbelts (in the region of 1.5 tonnes for a 75kg person). Seatbelt anchorages together must withstand these large loads from the seatbelts. These loads in turn must be dissipated by the vehicle structure.

In assessing the strength of the anchorages, it is essential to consider

- the vehicle structure in the immediate vicinity of the anchorage, and
- the parts of the vehicle structure into which the loads from the anchorages will be dissipated.

Sliding Seats

Some seats are fitted to a system of “runners” so as to allow fore and aft adjustment or to provide two alternative positions of use. Some of the belt anchorages for such seating positions may be attached to the seat. Before making any assessment of the belt anchorages, documentary evidence should be sought to confirm that the seat and runner assembly is capable of satisfying the requirements of the Directive when tested **independently** of the vehicle. Once this has been confirmed, the installation of the seat in the vehicle can be assessed.

On seats where some of the anchorages are in the seat structure and some in the vehicle structure, the relevant requirements for each anchorage point will apply, i.e., for the anchorage in the structure the relevant parts of section (1) apply, and for the seat the relevant parts of section (2) must also be met.

(1) Where seat belt anchorages are contained in the vehicle structure

- Anchorages in thin and/or flat panels should have reinforcing structure at least 75 x 75 x 4mm thick welded to the panel.
- There should be an adequate load path to the vehicles/cabs main structural members.
- Welding should appear neat and of good quality; and should not show signs of gaps or visible lack of penetration. (Whilst it is impossible to judge the quality of a weld just by looking at it, messy welding is rarely strong welding).
- Bolts used in structural areas should be of grade 8.8 or better. (Such bolts will be marked 8.8 or 12.9 on the hexagonal head), however, cap-head bolts or 7/16” (11mm) UNF seat belt anchorage bolts (with an anodised finish) not marked in this way will be considered to be of equivalent strength. Bolts should be M8 or larger.
- Where threaded bushes are fitted to tube section structure they should be welded (at both ends) through the tube and not end mounted on the surface. (A threaded bush may be attached by its side surface to a structural component).

(2) Where seat belt anchorages are contained within the seat

Seat criteria

- An approval or test certificate from a recognised test authority must be provided to show that the seat itself is capable of meeting the strength and anchorage positional requirements of Directive 76/115/EC as amended. It should typically include at least the following information:

Seat make and model,
Vehicle category (N2 or N3) (or alternatively M1, M2 can be accepted in place of N2 and M1, M2 or M3 can be accepted in place of N3),
Seat type (single/double or triple),
Belts fitted (3-point or lap),
Pedestal height,
Mounting details (i.e., on tracking or rigidly, mounted to a base plate).

Seat mounting criteria

Fixed Single Seats or rows of single seats mounted directly to the steel plate floor

- Load spreading plates at least 75 x 75 x 4mm thick must be fitted between the front legs of the seat and the **inside** of the vehicle floor (See figure 1).
- Load spreading plates at least 75 x 75 x 4mm thick must be fitted between the rear leg securing nuts and the **underside** of the vehicle floor (See figure 1).
- In some cases, the mounting bolts will pass through slotted holes in the load spreading plate to allow for adjustment. Suitable arrangements must be in place (e.g., oversized washers) to prevent the nut or the head of the bolt from pulling through the slot in the plate.
- Where the rear mounting bolts are located within 40mm of a chassis/structural member, the plate may be folded (not reduced in size) to clear the obstruction and the fold should abut snugly against the chassis/structural member (see **Figure 1**).
- Where two or more single seats each having separate pedestals are mounted within 200mm of each other, to form a row of seats. Such seats must be fitted with reinforcing members under the vehicle floor. The reinforcement needs to consist of one longitudinal 75mm wide channel section per seat pedestal underneath the floor. The height and thickness of the channel will be a minimum of 38mm and 5mm, respectively. Load spreading plates should still be fitted between the front seat legs and the inside of the vehicle floor. In all cases, the ends of the channel sections must abut snugly against the bearers immediately in front of and behind the seat concerned.
- The channel ends must be free of sharp edges, which may tear the vehicle floor under load.
- ALL** the mounting holes provided in each pedestal for securing the seat to the vehicle must be utilised, with the correct sized bolt for the hole, unless documentary evidence is available to show an alternative fixture.
- Seat mounting bolts that pass through hollow section reinforcing members must be fitted with "anti-crush tubes".
- Single seats with integral 3-point belt anchorages, attached to the vehicle floor and a wheel arch, via offset or asymmetrical legs must have documentary evidence from the seat manufacturer to confirm that the seat itself can withstand the forces required by the Directive when tested

independently of the vehicle on its offset pedestals. The outboard leg of the seat mounted through the arch requires a bridge structure secured to the underside of the arch (The security does not require welding but could be for example the seat mounting bolts that pass through the structure). This structure should span the arch, and if flat plate should be at least 75mm wide and 4mm thick, if channel or box section is used it should be of equivalent strength to the flat plate.

Fixed double seats mounted directly to the steel plate floor

- Double seats with a minimum of two pedestals and integral belt anchorages fitted directly to the vehicle floor, should be fitted with substantial channel or box section reinforcements under the vehicle floor.
- These must run longitudinal under each of the legs and extend as far forward and rearward as the next structural cross member.
- Channel sections should be at least 76mm x 38mm x 5mm positioned with the flanges facing downwards. If box sections are used, similar exterior dimensions should be used, and the wall thickness must be at least 4mm.
- The channel ends must be free of sharp edges, which may tear the vehicle floor under load.
- In addition, reinforcing plates at least 100mm x 100mm x 4mm must be fitted between the front legs and the inside of the vehicles steel floor.
- **ALL** the mounting holes provided in each pedestal for securing the seat to the vehicle must be utilized, with the correct sized bolt for the hole, unless documentary evidence is available to show an alternative fixture.
- Seat mounting bolts that pass through hollow section reinforcing members must be fitted with “anti-crush tubes.” (Because these crush tubes are usually not visible in the completed vehicle the onus would be on the presenter to satisfy the Approval Officer these were fitted).
- The channel ends must be free of sharp edges, which may tear the vehicle floor under load.

Fixed triple seats mounted directly to a steel plate floor

It is not, generally, possible to secure such seats using simple reinforcements alone. If a triple seat is fitted with three-point integral anchorages, documentary evidence that the complete assembly has been successfully tested “in-vehicle” should be sought.

Removable Single and Double seats fitted in tracking mounted to a steel plate floor

There are 3 general types of tracking used:-

Low Profile tracking (this can be regarded as any tracking system with a section depth of up to 30mm) (See figure 1) or

“Heavy Duty” tracking (this can be regarded as any tracking system with an overall depth of 30mm or more) (See figure 1) or

Dedicated clamping mechanisms attached to the floor of the vehicle. (These will need documentary evidence of compliance including mounting to the vehicle)

Low Profile tracking systems fitted to a steel plate floor

- Attached to the vehicle using 8mm (grade 8.8 or better) fasteners no more than 105mm apart.
- “Self-tapping” screws and “riv-nuts” are not considered as being of equivalent strength (unless documentary evidence can be provided).
- Load spreading washers or plates should be fitted under the vehicle floor.
- If plain washers are used, these should be a minimum of 50mm diameter and 3mm thick.
- In cases where the centre of a securing bolt is within 20mm of a chassis member, the washer may be cropped to clear the cross member.
- If plates are used, these should be a minimum of 35mm wide and 3mm thick and should present a rounded edge of at least 2mm radius towards the sheet steel floor.
- Plates and washers should, wherever possible, either span adjacent corrugations or approximately follow the contours of the corrugations.
- **ALL** the mounting holes provided in each pedestal for securing the seat to the tracking must be utilised.
- **ALL** the mounting holes provided to secure any given length of tracking to the vehicle must be utilised.
- Tracking must be installed in a continuous length without joints.
- Tracking mounting bolts that pass through hollow section reinforcing members should be fitted with “anti-crush tubes”.
- In some cases, the mounting bolts will pass through slotted holes in the load spreading plate to allow for adjustment. Suitable arrangements must be in place (e.g., oversized washers) to prevent the nut or the head of the bolt from pulling through the slot in the plate.
- The channel ends must be free of sharp edges, which may tear the vehicle floor under load.

Requirements for Heavy Duty tracking systems fitted to a steel plate floor

Although these differ in appearance, they all share the same principal feature – i.e., a much deeper section than the “low profile” tracking systems (30mm or more). These lengths of tracking have sufficient depth of section to resist the large bending loads applied during a seat belt anchorage test (See figure 1).

- Attached to the vehicle using 8mm (grade 8.8 or better) fasteners no more than 300mm apart.
- “Self-tapping” screws and “riv-nuts” are not considered as being of equivalent strength (unless documentary evidence can be provided).
- Load spreading washers or plates should be fitted under the vehicle floor.
- If plain washers are used, these should be a minimum of 50mm diameter and 3mm thick.
- In cases where the centre of a securing bolt is within 20mm of a chassis member, the washer may be cropped to clear the cross member.
- If plates are used, these should be a minimum of 35mm wide and 3mm thick and should present a rounded edge of at least 2mm radius towards the sheet steel floor.
- Plates and washers should wherever possible, either span adjacent corrugations or approximately follow the contours of the corrugations.

- **ALL** the mounting holes provided in each pedestal for securing the seat to the tracking must be utilised.
- **ALL** the mounting holes provided to secure any given length of tracking to the vehicle must be utilised.
- Tracking must be installed in a continuous length without joints.
- Tracking mounting bolts that pass through hollow section reinforcing members should be fitted with “anti-crush tubes”.
- In some cases, the mounting bolts will pass through slotted holes in the load spreading plate to allow for adjustment. Suitable arrangements must be in place (e.g., oversized washers) to prevent the nut or the head of the bolt from pulling through the slot in the plate.
- The channel ends must be free of sharp edges, which may tear the vehicle floor under load.

Figure 1

Load Spreading Plates

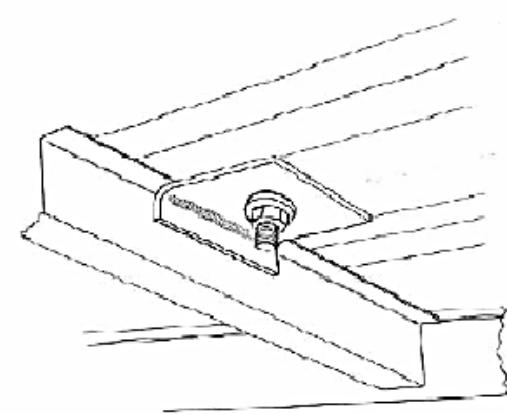
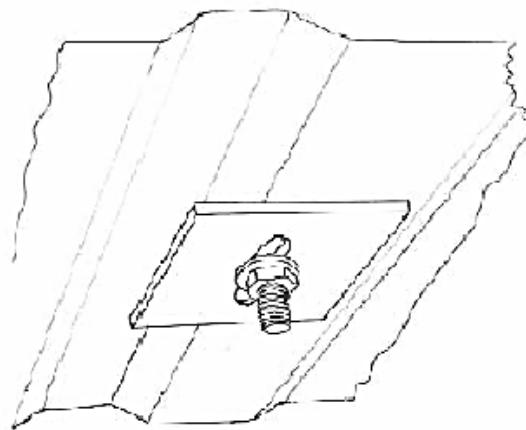
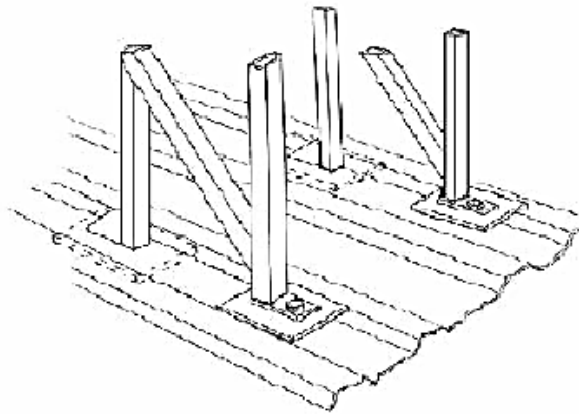

Low Level Tracking

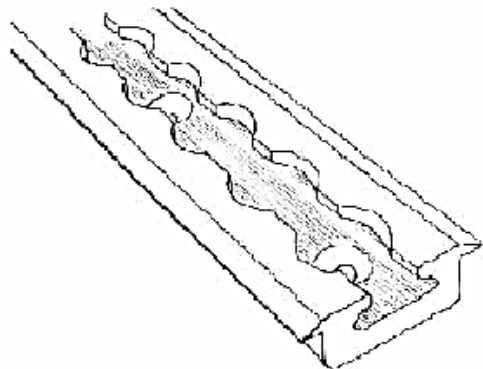

Heavy Duty Tracking

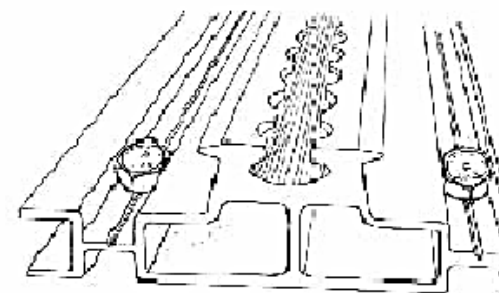

Annex 3 Reference Zone Equipment

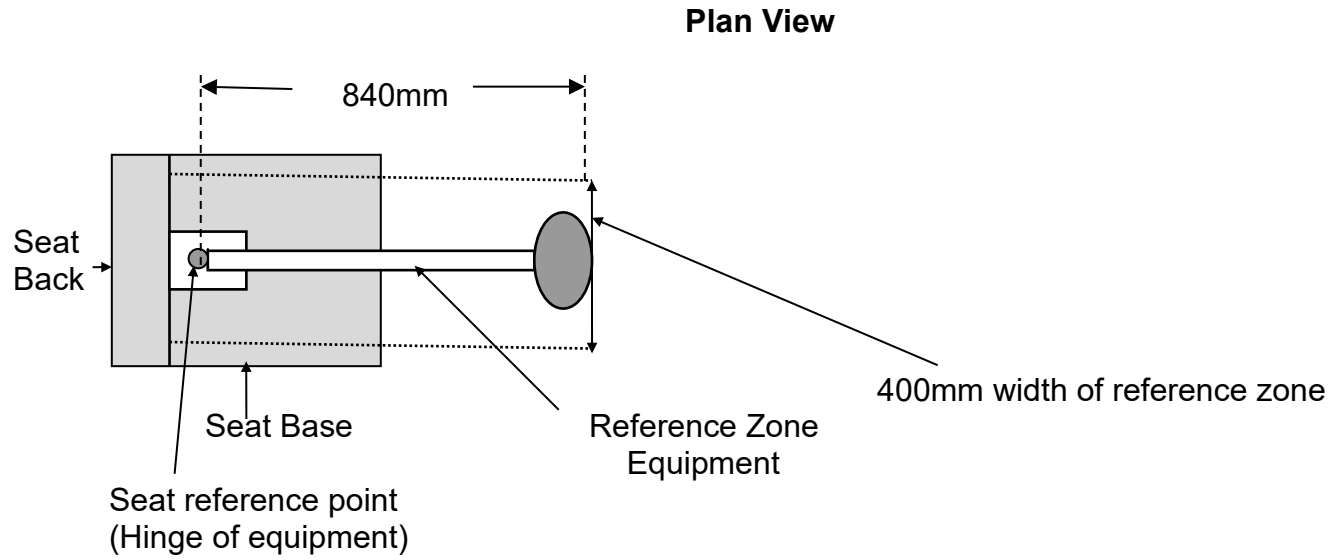

Record of Revision

Revision	Date	Description of Change
1	24/04/2009	
2	16/08/2010	Remove the reference to light vehicles from the section and reword MOI
3	31/07/2011	Add new Annex 1, 2 and 3
4	30/04/2012	Change minimum anchorage requirement in RS 1
5	03/02/2014	Revise RS4 and insert new note 4 & RS7

This page intentionally left blank

20 Installation of Lights

Application: All Vehicles

Method of Inspection	Required Standard
<p>The examiner will perform a visual check of all lamps and reflectors fitted to the vehicle for the correct colour light visible to the front or rear and that no light emitting surfaces are obscured.</p> <p>Lamp/reflector lateral position is measured from the extreme outer edge of the vehicle (disregarding the deflected part of the tyre walls immediately above the point of contact with the ground, mirrors, lamps and reflectors) to the edge of the illuminated area (or reflective surface on a reflector) nearest that side of the vehicle.</p> <p>Lamp/reflector vertical position is measured from the ground:</p> <ul style="list-style-type: none"> • In the case of the minimum height to the lower edge of the illuminated area (reflective surface on a reflector) • In the case of the maximum height to the top edge of the illuminated area (reflective surface on a reflector). <p>For the purposes of the test, lamps that are intended to illuminate the road forward of the vehicle are considered to be either:</p> <ol style="list-style-type: none"> a) main beam headlamps (including spot lamps and driving lamps) b) dipped beam headlamps, or c) front fog lamps. 	<ol style="list-style-type: none"> 1. The vehicle must be fitted with lamps or retro reflective material only capable of showing a white light to the front except for: <ul style="list-style-type: none"> • an amber light from a direction indicator • a yellow light from a front fog lamp • an amber light from a side marker light • emergency vehicles only, a blue light from a warning lamp or beacon. • an amber light from a hazard beacon / warning lamp • a yellow light from a conspicuity marking material • a red light from a rearmost side marker or rear position lamp 2. The vehicle must be fitted with lamps or retro reflective material only capable of showing a red light to the rear except for: <ul style="list-style-type: none"> • an amber light from a direction indicator • a white light from a work lamp, reversing lamp, interior lamp, or a registration plate lamp • a yellow light from a rear registration plate • an amber light from a side marker light • emergency vehicles only, a blue light from a warning lamp or beacon. • an amber light from a hazard beacon / warning lamp • a yellow light from a conspicuity marking material 3. The operation of any lamp must not affect any other lamp or be affected by the operation of any other lamp, unless specifically designed to do so. 4. All lamps, reflectors and rear markers must be securely fitted to the vehicle and not move by swivelling, deflecting or otherwise while the vehicle is in motion, except for:

Method of Inspection	Required Standard
<p>If workshop tools or equipment are required to reinstate the function of a lamp that 'lamp' should be considered not 'fitted'. If a stop lamp meets the criteria of an optional lamp and is 'fitted', i.e., connected, it must operate.</p> <p>Two or more lamps (see "A" and "B" in Figure 4, Figures 4a & 4b), whether identical or not, having the same function and emitting light of the same colour are considered to be one lamp if the aggregate illuminated area of the lamps occupies 60% or more of the area of the smallest rectangle circumscribing those illuminated areas, or where the distance between the edges of two neighbouring parts of the apparent surface of the illuminated area are less than or equal to 75 mm apart when measured straight from the axis.</p> <p>Note 1: This does not apply to rear retro reflectors which must be visible at all times.</p> <p>Note 2: Fixed position of a movable component means the stable or natural rest position(s) of the movable component which can be specified by the manufacturer, whether locked or not.</p>	<ul style="list-style-type: none"> • any lamp or reflector which by design can be deflected to the side with the movement of the front wheel or wheels of the vehicle when turned for the purpose of steering the vehicle • a headlamp for adjustment or dipping of the beam • a headlamp which can be retracted or concealed • a work lamp, used to illuminate a working area or the scene of an accident, breakdown, or road works in the vicinity of the vehicle to which it is fitted. <p>5. All obligatory and optional lamps, reflectors and rear markers must be fitted to their correct orientation.</p> <p>6. When every door, tailgate, boot lid, or other movable part is in the fixed open position (any movable component, with or without a light-signalling device installed on it, in any fixed position (see Note 2) different from the 'normal position of use') each of the:</p> <ul style="list-style-type: none"> • front and rear position lamps • front and rear indicators • rear retro reflectors <p>must fulfil one of the following conditions:</p> <p>a. half (50%) of the apparent surface of the lamp / reflector is visible from directly in front of / behind (as appropriate) the vehicle, or</p> <p>b. additional fully visible lamp (s) / reflector (s) satisfying all requirements for the above lamps / reflectors are activated / visible, or</p> <p>c. a notice in the vehicle must inform the user that in certain positions of the movable components, other road users should be warned of the presence of the vehicle on the road (e.g., by laying out a warning triangle) (see Note 1).</p>

Figure 1

Horizontal Angles of Visibility

Each lamp and reflector must be positioned such as to provide an “apparent surface.” At least 50% of the “apparent surface” of each lamp or reflector must be visible from any point within the relevant angles.

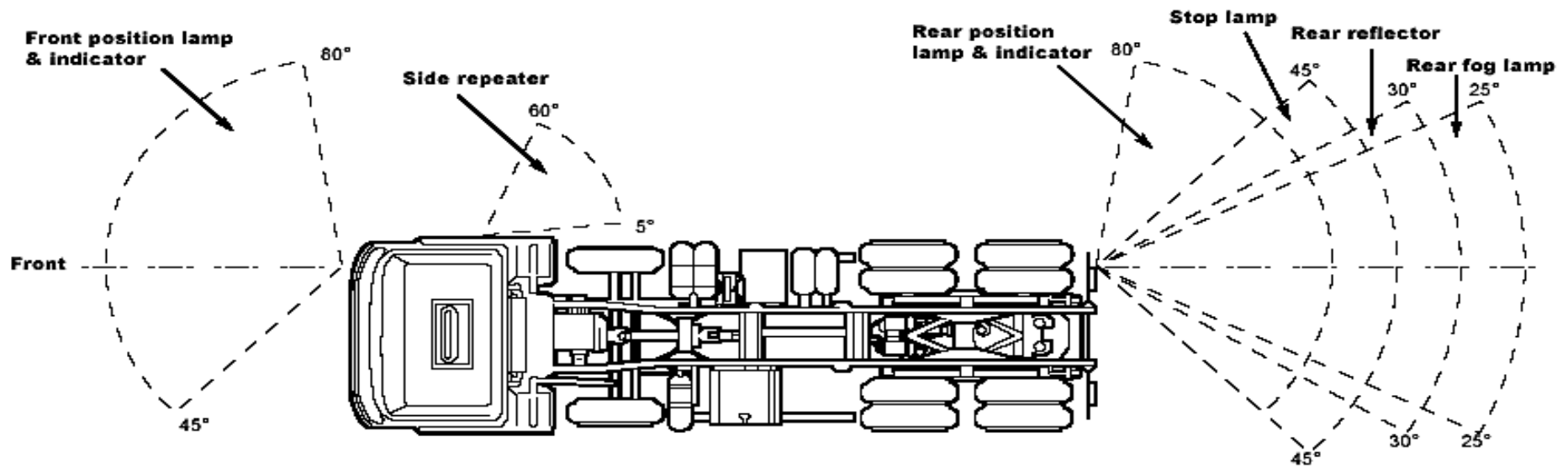

Figure 2

Vertical Angles of Visibility

Each lamp and reflector must be positioned such as to provide an “apparent surface”. At least 50% of the “apparent surface” of each lamp or reflector must be visible from any point within the relevant angles.

Front Position Lamps and Indicators (including Side Repeaters)

‘a’ = less than 750mm above ground level.

‘b’ = 750mm or more above ground level.

‘c’ = Rear position lamps and Stop lamps 1500mm or more above ground level. Indicators and Rear reflectors 750mm or more above ground level.

‘d’ = Rear position lamps and Stop lamps less than 1500mm above ground level.

‘e’ = Rear position lamps, Stop lamps, Indicators and Rear reflectors less than 750mm above ground level.

‘f’ = Rear fog lamps.

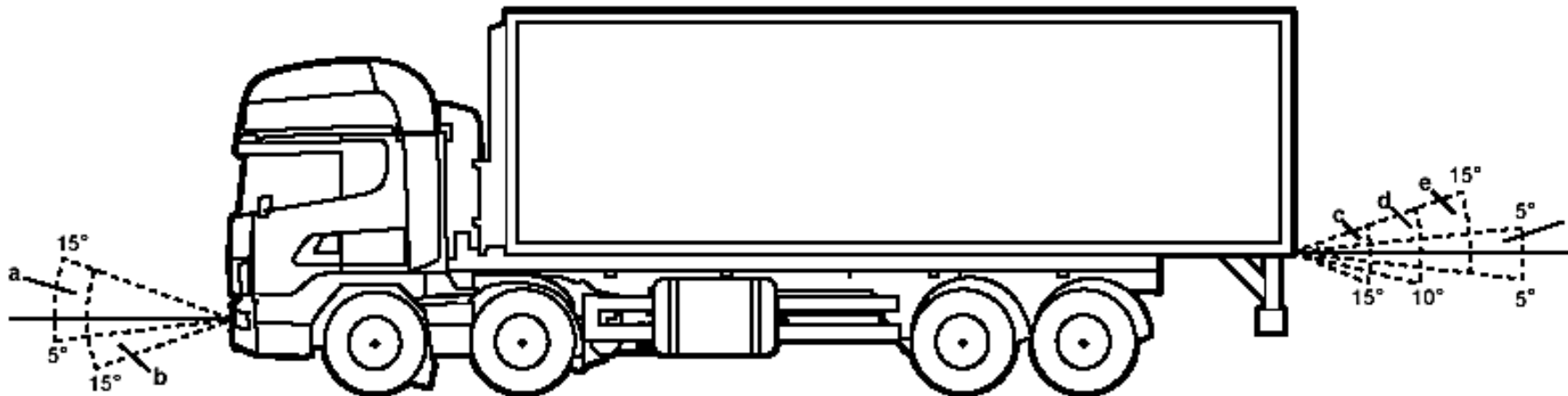

Figure 3

“To the rear” of the vehicle means:

If viewed from an observer moving within an area shown in the diagram below (Zone 1), the sides of which are at an angle of 15 degrees out from the extreme outer edge of the vehicle starting from the rear corner and extending up to **25m** from the rear of the vehicle (measured along the vehicle longitudinal), no light other than a red light (with the exception of amber light from a direction indicator, white light from a work lamp, reversing lamp, or a registration plate lamp or yellow light from a registration plate lamp) is permitted to be visible in this area.

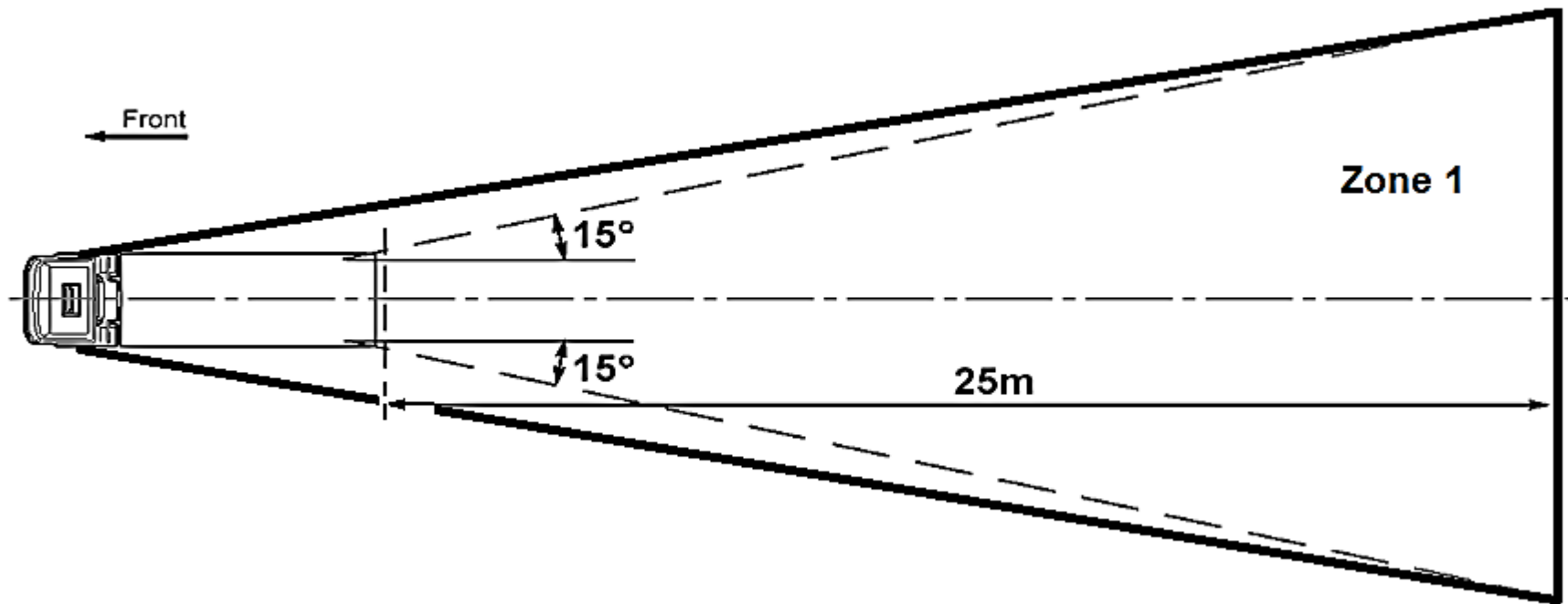

Figure 3a

“To the front” of the vehicle means:

If viewed from an observer moving within an area shown in the diagram below (Zone 2), the sides of which are at an angle of 15 degrees out from the extreme outer edge of the vehicle starting from the front corner and extending up to **25m** from the front of the vehicle (measured along the vehicle longitudinal), no light other than a white light (with the exception of an amber light from a direction indicator, an amber light from a hazard beacon/warning lamp, a yellow light from a front fog lamp, a yellow light from a front end outline marker lamp, an amber light from a side marker light, a red light from a rearmost side marker or rear position lamp; and emergency vehicles only, a blue light from a warning lamp or beacon) is permitted to be visible in this area.

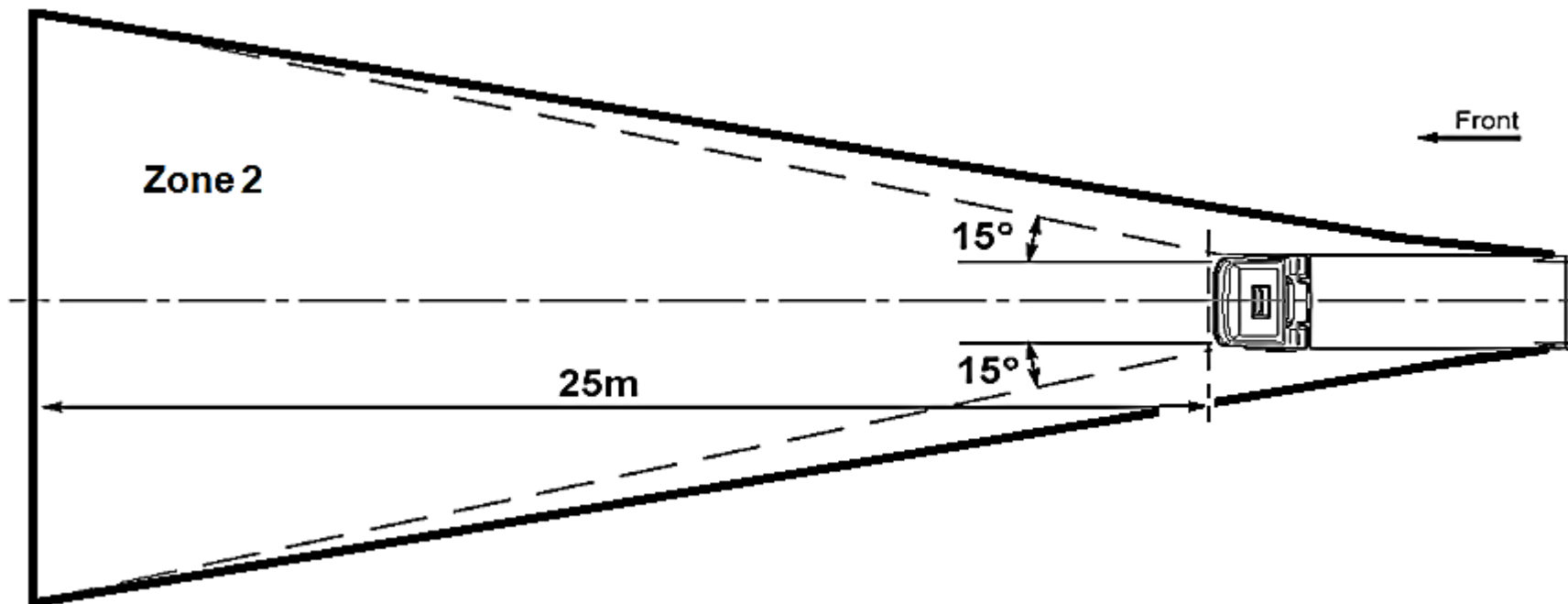

Figure 4

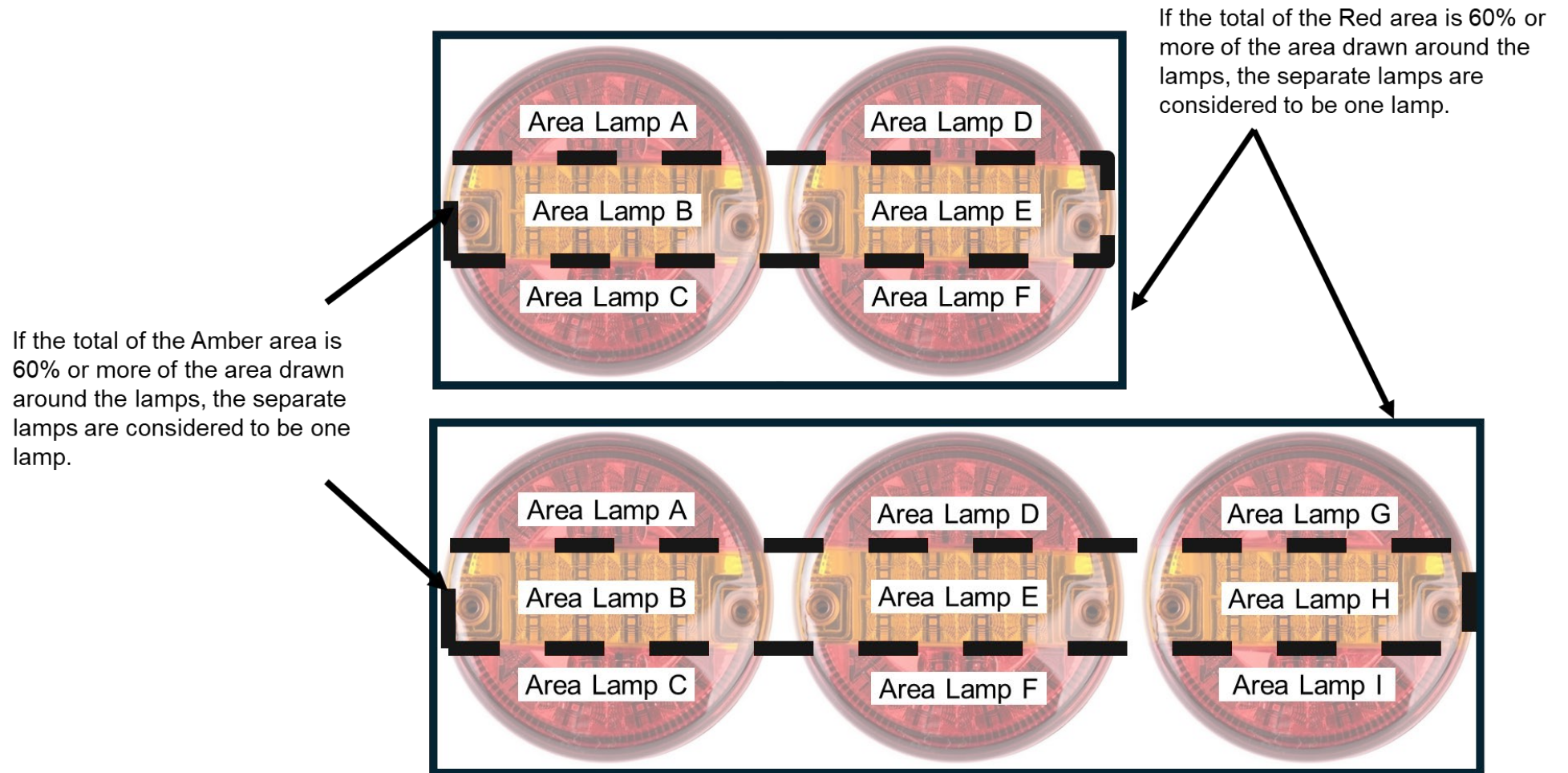

Figure 4a

If the total of area "A" added to area "B" is 60% or more of the area drawn around the lamps, the lamps are considered to be one lamp.

Smallest rectangle that can be drawn around the two areas "A" and "B"

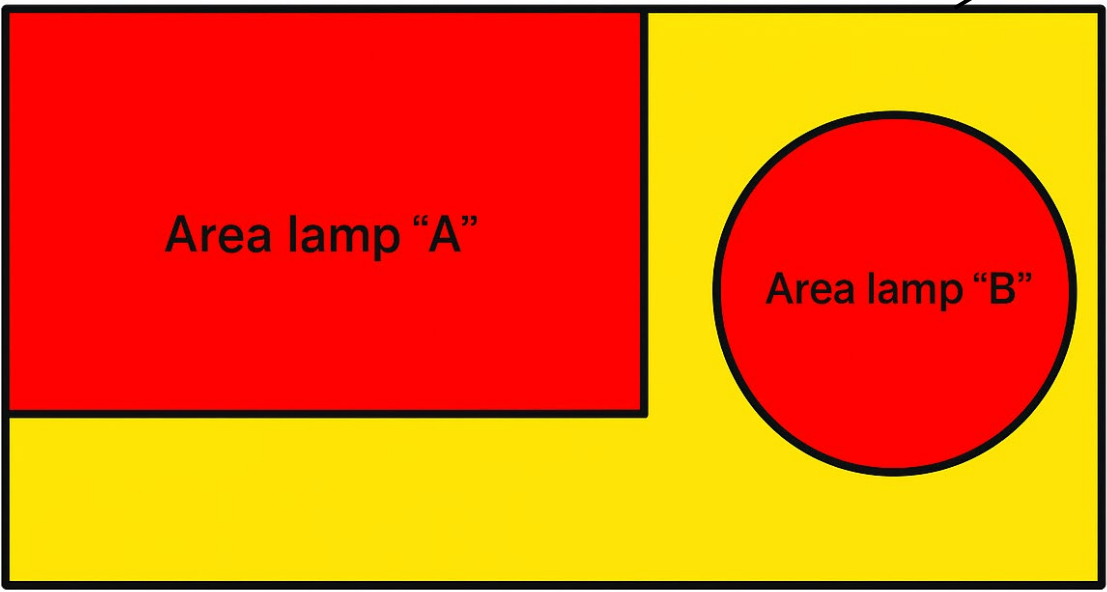
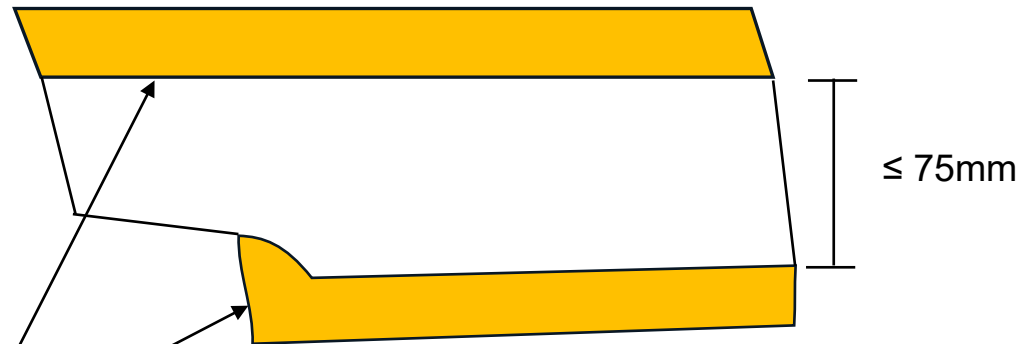

Figure 4b



Example

The Direction indicator is considered to be a single lamp if the distance between the edge of the two neighbouring parts of the apparent surface of the illuminated area are less than or equal to 75mm



Figure 5

The methodology for assessing lamp separation

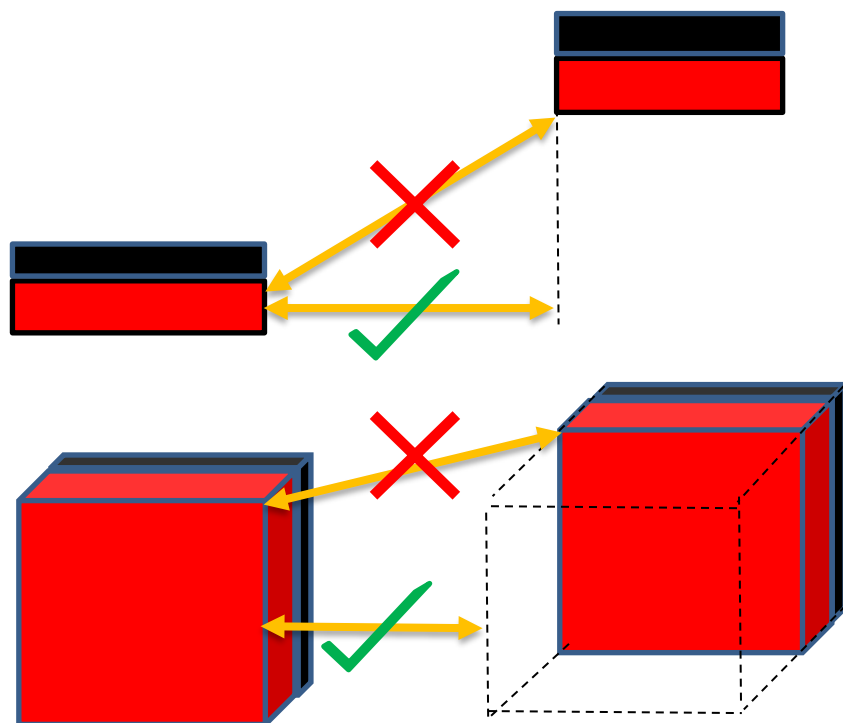

Measuring lamp separation viewed in plan form (from above).

Measuring the same lamp separation viewed in end elevation (directly behind the vehicle)

UNECE Regulation 48.03 (6.13.9), End Outline Marker Lamp requirements:

The position of an end outline marker lamp in relation to corresponding position lamp shall be such that the distance between the projections on a transverse vertical plane of the points nearest to one another on the apparent surfaces in the direction of the respective reference axes of the two lamps considered is not less than 200 mm.

Note: Check each lamp against its specified separation dimension in its section of the manual. This applies equally to Conspicuity Markings.

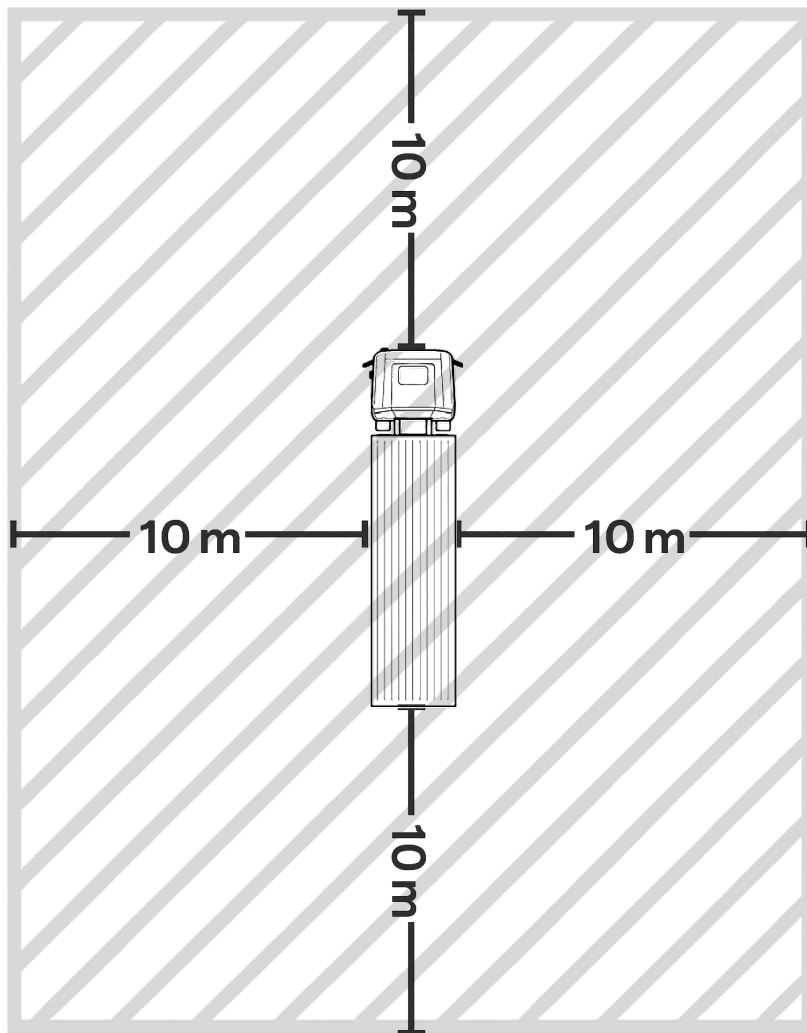
Figure 6**Manoeuvring Lamps**

When illuminated, the apparent surface of manoeuvring lamps must not be directly visible from any of the following positions:

- From a point moving along a line 10 metres in front of the vehicle
- From a point moving along a line 10 metres behind the vehicle
- From points moving along lines 10 metres to the left and right sides of the vehicle

Note: All four lines run parallel to the ground, and the observer's eye height is between 1 metre and 3 metres.

Record of Revision

Revision	Date	Description of Change
1	24/04/2009	
2	16/08/2010	Add RS3, add Note 3 and link to RS5c
3	31/07/2011	Add bullet points for conspicuity markings to RS1 and RS2
4	03/02/2014	Remove reference to Notes 1 & 2, Note 3 becomes Note 1, insert two new paragraphs in Mol & new Figure 4
5	29/10/2014	First paragraph of Mol corrected
6	10/04/2018	Amend Figure 4
7	01/09/2020	Insert new Figure 5.
8	20/10/2023	Revise RS1 to Include allowance of red light from front (TSE IVA N2N3 020 008). Revise Fig 3 to define zone area, and insertion of Figure 3a diagram and associated text to clarify 'view to the front and rear' (TSE IVA N2N3 020 008). Revise RS6 to clarify 'fixed open position' & create Note 2 referenced from RS6. (TSE IVA N2N3 020 006). Revision of Figure 4 to align with other IVA manuals. (TSE IVA N2N3 020 007).
9	28/11/2025	Revise MOI to clarify consideration of tyres (TSE IVA N2N3 020 009). Revise 'Two or more lamps' paragraph in MOI & add Figure 4b (TSE IVA N2-3 020 010).
10	11/05/2026	Improved format of Figures 4 & 4a. Added Figure 6.

21 Retro Reflectors

Application: Reflectors: **All Vehicles**,
 Conspicuity Markings: **Rigid Vehicles over 7500kg DGW, over 6.0 metres long and over 2.1 metres wide**

Method of Inspection	Required Standard
<p>Carry out a visual check of all retro reflectors, conspicuity markings, and rear markers fitted to the vehicle for colour, number, approval markings, and correct positioning.</p> <p>Vehicles are required to have a full contour marking on the rear, i.e., horizontal, and vertical markings to outline the shape of the vehicle, and partial contour markings on the side. Partial contour markings consist of a horizontal line showing the length of the vehicle and 'tick' marks showing the upper corners of the vehicle (see figure 1, 2 & 3).</p> <p>For the purposes of this inspection, 'if built into a lamp cluster' means grouped with another lighting function.</p> <p>Note 1: Geometric angles of visibility and positional requirements are not required for all optional reflectors, or markers.</p> <p>Note 2: Where the shape, structure, design, or operational requirements make it impossible to install the mandatory contour marking, a line marking is acceptable. (See figure 6).</p> <p>Note 3: Example of an Approval Mark</p> <div style="display: flex; align-items: center; margin-top: 10px;"> <div style="text-align: center; margin-right: 10px;"> <p style="font-size: small;">c</p>  </div> <div> <p>Symbol "C" indicates the class of the retro-reflective material which is intended for contour/strip marking.</p> </div> </div> <p style="font-size: x-small; margin-top: 5px;">104 R - 0001148</p>	<p>Reflectors</p> <ol style="list-style-type: none"> 1. All reflectors must be 'e' or 'E' marked, and where applicable, bear the appropriate identity marking as listed in Table 1. 2. The correct number must be fitted to the vehicle (Table 1). 3. The correct colour must be fitted to the vehicle (Table 1). 4. They must be positioned to meet: (see Note 1) <ol style="list-style-type: none"> a) the positional requirements of Table 1 b) the angles of visibility requirements of Table 1 5. They must be of the correct shape (Table 1). 6. Rear reflectors must face predominately to the rear. <p>Conspicuity Markings; vehicles over 7500kgs DGW, over 6.0m long and over 2.1m wide</p> <ol style="list-style-type: none"> 7. Full or part conspicuity markings must be fitted (see Note 2) 8. All conspicuity marking material must be of an approved type (see Note 3). 9. There must be at least one visible approval mark on any element of a retro-reflective marking material fitted to each face of the vehicle (O/S, N/S & Rear).

Method of Inspection	Required Standard
<p>Note 4: Markings are considered continuous if gaps are less than 50% of the length of adjacent elements, However, if the manufacturer can prove to the satisfaction of the authority responsible for type approval that it is impossible to respect the value of 50 per cent, the distance between adjacent elements may be larger than 50 per cent of the shortest adjacent element, and it shall be as small as possible and not exceed 1000 mm.</p> <p>Note 5: If 1500mm is not practicable this can be increased to 2500mm.</p> <p>Note 6: Rear marker plates (R70.01) count towards cumulative total width of conspicuity marking.</p> <p>Note 7: The 70% (minimum) is calculated based on overall vehicle length. The figure you arrive at must be distributed over the cab and body, i.e., assuming the vehicle was 10 metres long then the marking must equate to at least 7 metres. This 7 metres (or more if required) of marking must then be distributed across both the cab and the body, there is no requirement for 70% of the cab to be marked.</p> <p>Note 8: Markings on vehicle cabs are only required to comply with RS8, 10, 11, 12, 13, 17 & 18</p> <p>Note 9: Where it is impractical to meet the dimension stated in RS21, e.g., due to the position of load covers or similar equipment, full or partial upper markings (where fitted) should be located as close as is practical to the upper extremity.</p> <p>Note 10: The 250mm must be measurable on a flat plane. If the mark is fitted to a shaped surface (e.g., corrugations) the mark must be extended so that at least 250 mm is visible from the side.</p>	<p>10. The maximum gap between adjacent elements must be no greater than 50% of the smallest adjacent element (see Note 4).</p> <p>11. The lowest edge must be between 250mm and 1500mm from the ground (see Note 5 & Figures 4,6 & 8).</p> <p>12. The minimum width of the markings must be at least 50mm.</p> <p>13. The maximum width of the markings must be no greater than 60mm.</p> <p>Rear Conspicuity Markings; vehicles over 7500kg and over 2.1m wide</p> <p>14. must be coloured either red or yellow</p> <p>15. must equate to at least 70% of the overall vehicle width (see Note 6 & Figure 5)</p> <p>16. must be at least 200mm away from any brake mandatory light (see Figure 4 A)</p> <p>Side Conspicuity markings; vehicles over 7500kg and over 6m long</p> <p>17. must be coloured either white or yellow</p> <p>18. must extend within 600mm of either end of the vehicle (see Figure 2)</p> <p>19. must equate to at least 70% of the overall vehicle length (see Notes 7 & 12 and figure 8)</p> <p>Vehicle Cabs (except Tractor Units)</p> <p>20. must be fitted with line markings (see Notes 8 & 12)</p> <p>If Full or Partial Contour Markings are fitted</p> <p>21. The maximum height must be as close as is practical to the top of the body. (see Figure 2) (see Note 9).</p>

Method of Inspection	Required Standard
<p>Note 11: Rear markers are not required to be fitted as long as the vehicle has been fitted with Conspicuity Markings which comply to the required standards of this section.</p> <p>Note 12: An alternative marking mode within 2,400 mm from the front end of the motor vehicle is allowed where a series of retro-reflectors of Class IV A of Regulation No. 3 or Class C of Regulation No. 104 are mounted followed by the required conspicuity marking as follows:</p> <ul style="list-style-type: none"> a) Retro-reflector size minimum 25 cm²; b) One retro-reflector mounted not more than 600 mm from the front end of the vehicle; c) Additional retro-reflectors spaced not more than 600 mm apart; d) The distance between the last retro-reflector and the start of the conspicuity marking shall not exceed 600 mm. 	<p>22. The vertical aspect of marking must be as close to the edge as practicable. (see Figure 4 B).</p> <p>23. Each side of a Tick Marking must be at least 250mm (see Note 10 and figure 3).</p> <p>Rear Markers; vehicles over 7500kgs (if fitted)</p> <p>24. All rear markers must bear a genuine permanently attached 'e' mark.</p> <p>25. A minimum of one set of obligatory markers must be fitted to the vehicle (see Note 11 and Table 2).</p> <p>26. They must be positioned correctly to meet the positional requirements of Table 2.</p> <p>27. They must be of the correct type (Table 2).</p>

Table 1

TYPE	NUMBER	APPLICATION	COLOUR	POSITION			ANGLES OF VISIBILITY See Figures 1 & 2 of section 20	APPROVAL MARK "E" or "e" Identity Symbol or BS Mark / Notes
				MAX DISTANCE FROM SIDE (mm)	MAX HEIGHT (mm)	MIN HEIGHT (mm)		
Rear Retro Reflectors Non-triangular	Min 2 Max any number (Includes optional)	Mandatory	Red	400 (Min separation 600 unless vehicle width less than 1300, where Min separation 400)	900 (1200 if built into a lamp cluster) or if impracticable due to body 1500	250	a. Horizontal i. 30° inwards and outwards. b. Vertical i. < 750mm above the ground 15° above and 5° below horizontal. ii. otherwise 15° above and below horizontal	IA or IB "E" or "e"
Front Retro Reflectors Non-triangular	Min 2 Max any number (Includes optional)	Mandatory on motor vehicles with concealable front lamps with reflectors. Optional on all other motor vehicles.	White	400	900 or if impracticable 1500	250	a. Horizontal i. 5° inwards and 30° outwards. b. Vertical i. < 750mm above the ground 15° above and 5° below horizontal. ii. otherwise 15° above and below horizontal	IA or IB "E" or "e"
Side Retro Reflectors Non-triangular	See below	Mandatory on all motor vehicles exceeding 6m in length Optional on other motor vehicles	Amber The rearmost reflector may be red if within 1m of the rear	N/A	900 (1200 if built into a lamp cluster) or if impracticable due to body 1500	250	a. Horizontal 45° to the front and to the rear b. Vertical i. < 750mm above the ground 15° above and 5° below horizontal. ii. otherwise 15° above and below horizontal	IA or IB "E" or "e"
<ul style="list-style-type: none"> at least one side reflector fitted to the middle third of the vehicle the foremost side reflector being not further than 3m from the front the distance between two adjacent side reflectors shall not exceed 3m, if the structure of the vehicle makes it impossible to comply with such a requirement, this distance may be increased to 4m the distance between the rearmost side reflector and the rear of the vehicle shall not exceed 1m Any reflectors fitted in addition to the above requirements will be assessed as optional. There is no restriction on the number of optional reflectors that may be fitted. 								

Figure 1

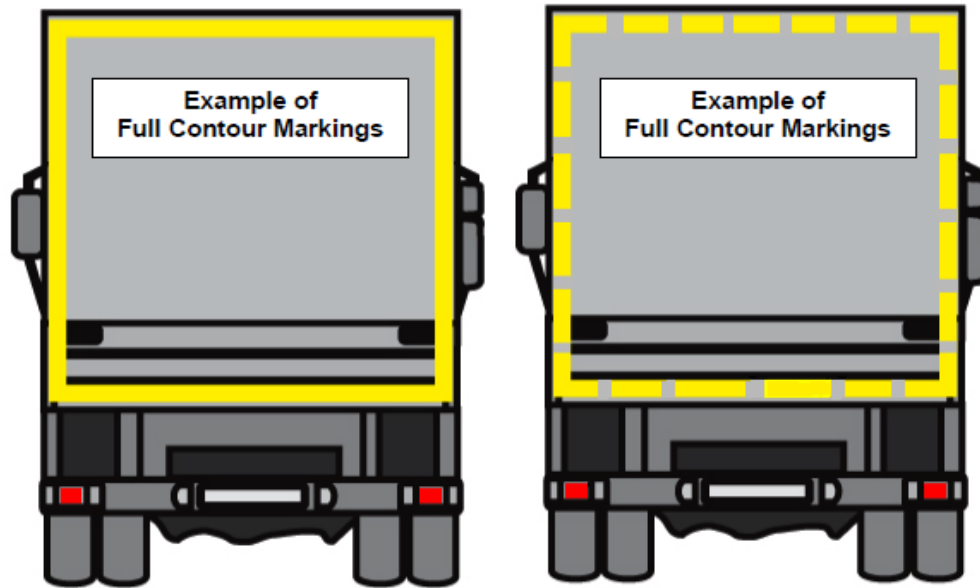

Figure 2

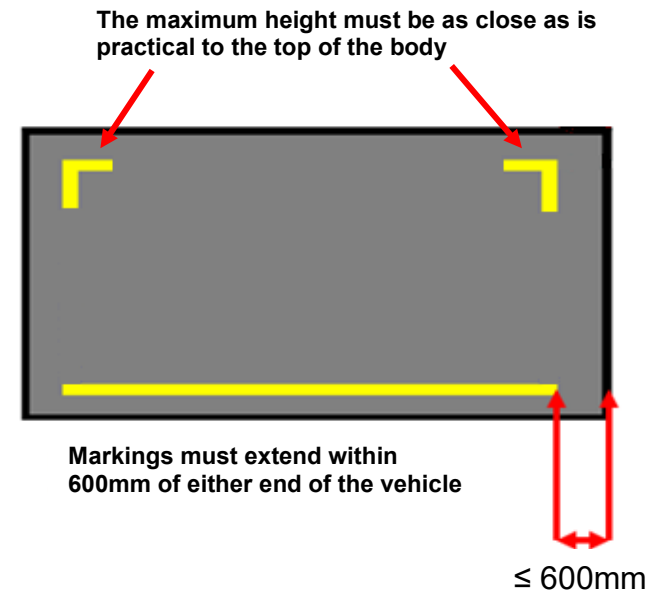

Figure 3

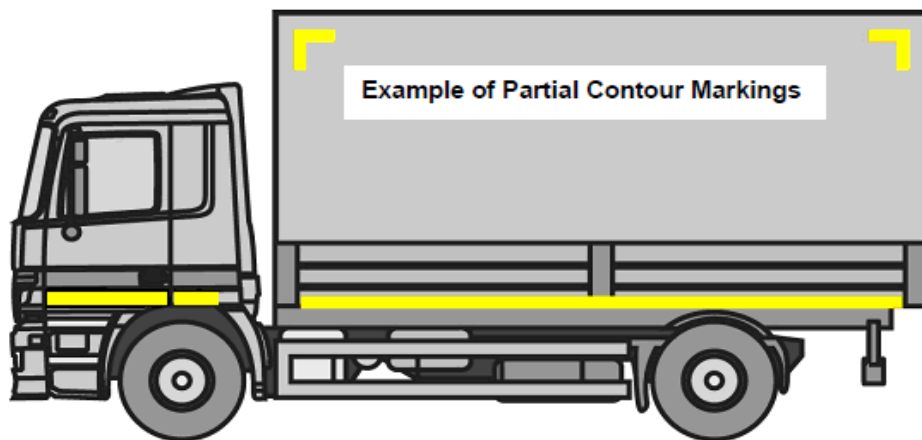
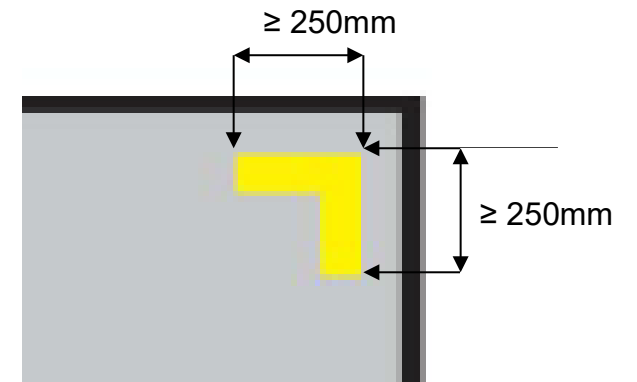

Figure 4 Rear marker plates are optional (A,B & C)

Where fitted rear marker plates may only be counted as contributing to the rear contour marking (C) provided they comply with UNECE Regulation 70.01

Marker plates approved to UNECE Regulation 70.00 do not count towards the conspicuity marking

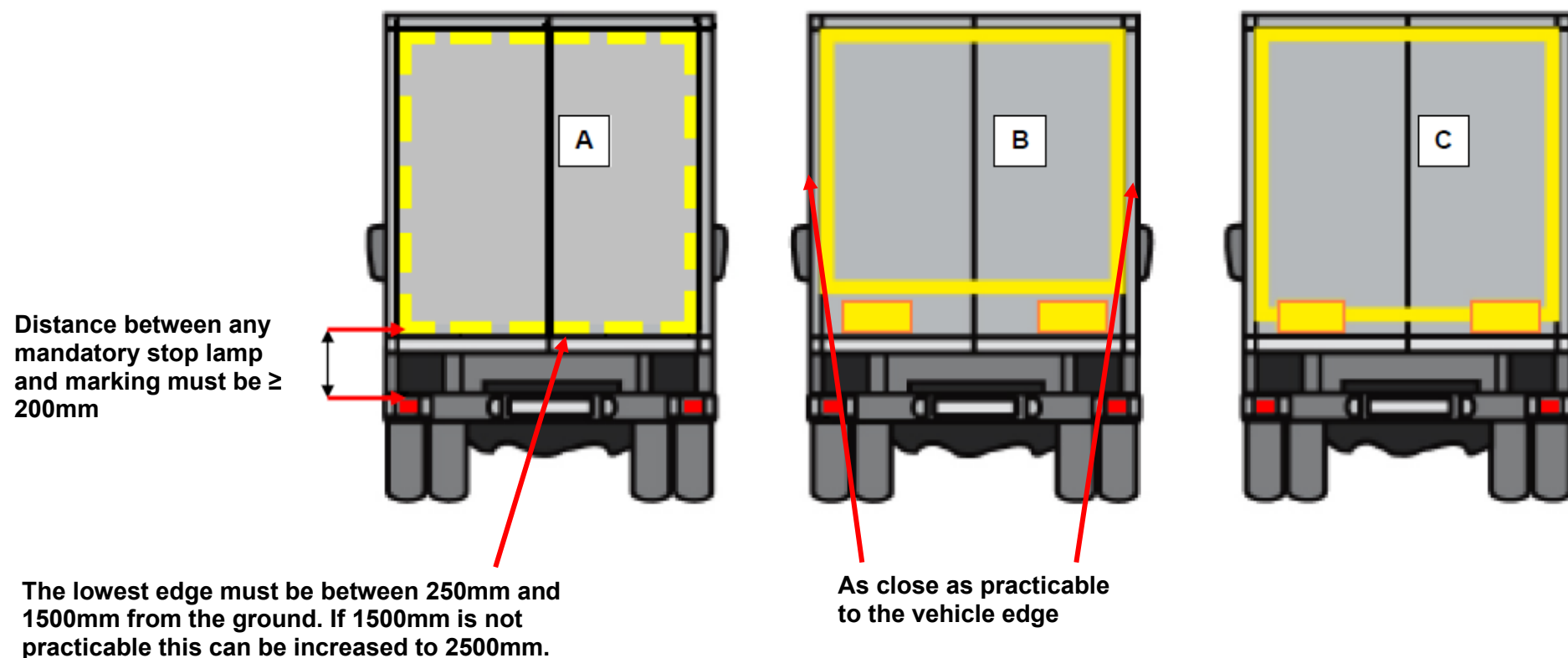

Figure 5

Markings must cover at least 70% of the overall vehicle width

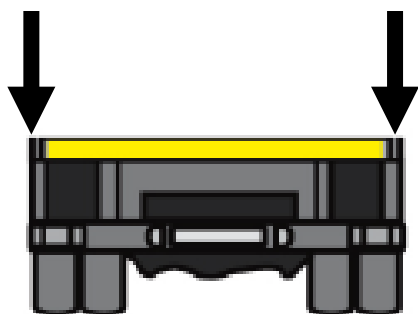

Figure 6

Markings are considered continuous if gaps are less than 50% of the length of adjacent elements

Typical example of a vehicle only requiring a line marking

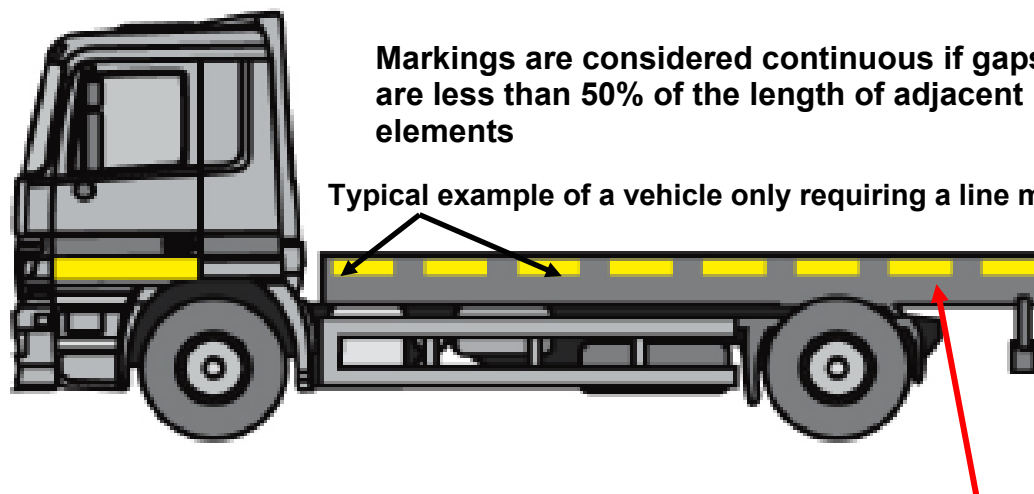

Figure 7

Distance between any mandatory stop lamp and marking must be $\geq 200\text{mm}$

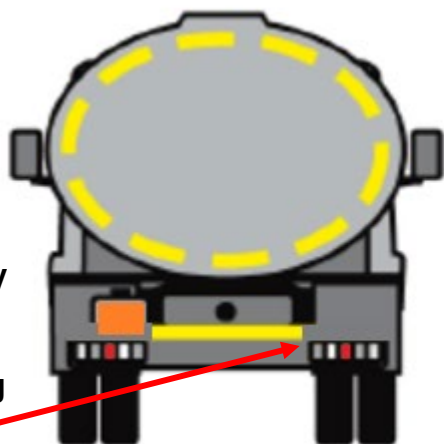

Figure 8

The lowest edge must be between 250mm and 1500mm from the ground. If 1500mm is not practicable this can be increased to 2500mm

Markings must cover at least 70% of the overall vehicle length

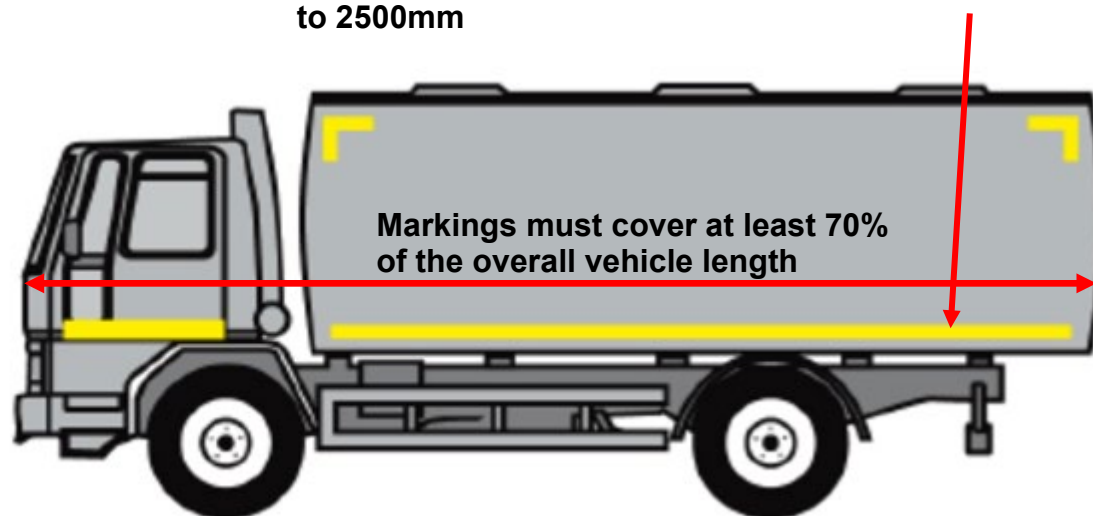



Table 2

1. Description	
A motor vehicle the overall length of which does not exceed 13m:	A rear marking of a type shown in diagram 1, 2, 3 or 4 in Part III of this Section.
A motor vehicle the overall length of which exceeds 13m:	A rear marking of a type shown in diagram 5, 6, 7 or 8 in Part III of this Section.
2. Position	
Longitudinal:	At or near the rear of the vehicle.
A rear marking of a type shown in diagram 2, 3, 4, 6, 7 or 8 in Part III of this Section:	Each part shall be fitted as near as practicable to the outermost edge of the vehicle on the side thereof on which it is fitted so that no part of the marking projects beyond the outermost part of the vehicle on either side.
A rear marking of a type shown in diagram 1 or 5 in Part III of this Section:	The marking shall be fitted so that the vertical centre-line of the marking lies on the vertical plane through the longitudinal axis of the vehicle and no part of the marking projects beyond the outermost part of the vehicle on either side.
Vertical:	The lower edge of every rear marking shall be at a height of not more than 1700mm nor less than 400mm above the ground whether the vehicle is laden or unladen.
3. Visibility:	Plainly visible to the rear.
4. Alignment:	The lower edge of every rear marking shall be fitted horizontally. Every part of a rear marking shall lie within 20° of a transverse vertical plane at right angles to the longitudinal axis of the vehicle and shall face to the rear.
5. Markings	<p>An approval mark to ECE Regulation 70 or 70:01</p> <p>Example Marking</p> <div style="text-align: center;">  </div>
6. Colour:	Red fluorescent material in the stippled areas shown in any of the diagrams in Part III of this Section and yellow retro reflective material in any of the areas so shown, being areas not stippled and not constituting a letter.

Part III

Rear markings prescribed for motor vehicles having a maximum gross weight exceeding 7500 kg (where required to be fitted)



Record of Revision

Revision	Date	Description of Change
1	24/04/2009	
2	16/08/2010	RS6 and 10 added and link note 1 to RS4
3	31/01/2011	Add Conspicuity Markings
4	31/07/2011	Amend Conspicuity Marking section
5	30/04/2012	Add Rigid to application box, reorder standards and renumber, add example marking for Marker Boards
6	29/10/2012	Insert new paragraph in Mol, reword statement on Figure 4 and remove labelling from tanker in Figure 7
7	03/02/2014	Remove para 2 from Mol,, reword paragraph 1, Note 1, insert new note 2, renumber remaining notes and insert new note 9.
8	29/10/2014	Conspicuity width and length requirement reduced from 80% to 70%, RS 15 & 19, figures 5 & 8 updated. New note 11 added link from RS 23. Height requirement has changed from 400mm to as close as practical, RS21 & Fig 2 updated.
9	01/09/2015	RS 21 referred to note 9
10	01/09/2020	New Note 12 permitting alternative conspicuity markings to the side of the vehicle (up to 2.4 m from the front).
11	20/10/2023	Amend Table 1 Max. Height Side Retro Reflectors. Add minimum height requirement to Figures 4, 6 & 8 referenced from RS11.
12	28/11/2025	Paragraph added to Mol to clarify 'if built into a lamp cluster'. Footnote added to Table 1 to include details regarding optional reflectors (TSE IVA N2N3 021 004). Figure 7 revised. Improved format of diagrams at Part III.
13	11/05/2026	Clarified positional allowance for Red rearmost side retro-reflectors in Table 1 (Colour).

22 End-outline, Position (Side), Stop, Side Marker & Daytime Running Lamps

Application: All Vehicles

Method of Inspection	Required Standard
<p>Carry out a visual check of all outline marker, position, stop, side marker and daytime running lamps fitted to the vehicle for operation, colour, number, approval markings and correct positioning.</p> <p>With optional lamps check that fitment is permitted and they do not exceed the maximum number of lamps allowed to be fitted.</p> <p>In addition to the Required Standards, vehicles MAY have EITHER of (1) or (2) below:</p> <p>(1) Direction indicator side repeater lamps Three category 5 side repeaters distributed as evenly as practicable along each side</p> <p>OR</p> <p>(2) Flashing Side marker lamps Mandatory amber side marker lamps may flash simultaneously with the direction-indicator lamps on the same side of the vehicle.</p> <p>Only one of the above specific combinations is allowed, no other combination is acceptable</p> <p>Where (2) above is used, there is NO requirement for the side marker lamps to be marked in addition as side repeater lamps</p> <p>Note 1: Standard does not apply when side marker lamps flash in conjunction with direction indicators.</p>	<ol style="list-style-type: none"> 1. All lamps must be 'e' or 'E' marked and where applicable, bear the appropriate identity marking as listed in table 1. 2. The front and rear position lamps, end outline marker lamps and side marker lamps, (if fitted) must be switched on and off by the operation of one switch (see Note 1). <p>Front and Rear Position Lamps</p> <ol style="list-style-type: none"> 3. The correct number must be fitted to the vehicle (Table 1). 4. They must be operational. 5. They must only emit white light to the front / red light to the rear. 6. They must be positioned to meet (see Note 2). <ol style="list-style-type: none"> a. the positional requirements of Table 1 b. the angles of visibility requirements of Table 1 <p>Stop Lamps</p> <ol style="list-style-type: none"> 7. The correct number must be fitted to the vehicle (Table 1). 8. They must be operational. 9. They must only emit red light. 10. They must only illuminate when the service brake is applied and must extinguish when the service brake is released.

End-outline, Position (Side), Stop, Side Marker & Daytime Running Lamps 22

Method of Inspection	Required Standard
<p>Note 2: Geometric angles of visibility and positional requirements are not required for all optional position lamps, stop lamps and end outline marker lamps.</p> <p>Note 3: The inspection of the side marker lamps applies to the obligatory lamps fitted to all vehicles exceeding 6m in length. Optional side marker lamps are to be assessed for colour, position, angles of visibility, and approval marking.</p> <p>Note 4: The correct orientation for side marker lamps is not required on the boom of Crash cushion vehicles.</p> <p>Note 5: The inspection of end-outline marker lamps applies to the obligatory marker lamps fitted to vehicles exceeding 2.10m in width.</p> <p>Note 6: Both front and rear end outline marker lamps can be combined in one device.</p> <p>Note 7: There is no requirement for special bracketry to be manufactured in order to accommodate these lamps.</p> <p>Note 8: Rear position lamps may be illuminated in conjunction with the front daytime running lamps. In addition to the rear position lamps, front position lamps, end-outline marker lamps, side-marker lamps, and rear registration plate lamp(s) may also be illuminated simultaneously.</p> <p>Note 9: Daytime running lamps must be connected so that they switch off automatically when the headlamps are on.</p>	<p>11. They must be positioned to meet (see Note 2)</p> <ul style="list-style-type: none"> a. the positional requirements of Table 1 b. the angles of visibility requirements of Table 1 <p>Side Marker lamps (see Notes 3 & 4)</p> <p>12. The correct number must be fitted to the vehicle (in accordance with the positional requirements).</p> <p>13. They must be operational.</p> <p>14. They must emit an amber light (red is acceptable if within 1 metre of the rear).</p> <p>15. They must be positioned to meet</p> <ul style="list-style-type: none"> a. the positional requirements of Table 1 b. the angles of visibility requirements of Table 1 <p>End Outline Marker Lamps (see Notes 5, 6, & 7)</p> <p>16. The correct number must be fitted to the vehicle (Table 1).</p> <p>17. They must be operational.</p> <p>18. They must only emit red light to the rear / white light to the front.</p> <p>19. The lights must be a minimum of 200mm from a positional lamp.</p> <p>20. They must be positioned to meet (see Note 1)</p> <ul style="list-style-type: none"> a. the positional requirements of Table 1

End-outline, Position (Side), Stop, Side Marker & Daytime Running Lamps 22

Method of Inspection	Required Standard
	<p style="text-align: center;">b. the angles of visibility requirements of Table 1</p> <p>Daytime running lamps (if fitted) (see Note 8)</p> <p>21. The correct number must be fitted to the vehicle (Table 1).</p> <p>22. They must be operational.</p> <p>23. They must only emit white light to the front.</p> <p>24. They must be positioned to meet</p> <p style="padding-left: 40px;">a. the positional requirements of Table 1</p> <p style="padding-left: 40px;">b. the angles of visibility requirements of Table 1</p> <p>25. They must extinguish automatically when headlamps are operated. (see Note 9).</p>

End-outline, Position (Side), Stop, Side Marker & Daytime Running Lamps 22

Table 1

TYPE	NUMBER	APPLICATION	COLOUR	POSITION			ANGLES OF VISIBILITY (see Figures 1 & 2 of Section 20)	APPROVAL MARK “E” or “e” Identity Symbol or BS Mark
				MAX DISTANCE FROM SIDE (mm)	MAX HEIGHT (mm)	MIN HEIGHT (mm)		
Front Position Lamps	Min 2 Max Any number (Includes optional lamps)	Mandatory	White	400	1500 or if impractical 2100	350	a. Horizontal i. 45° Inwards ii. 80° Outwards b. Vertical i. 15° Above and below the horizontal (May be reduced to 5° if the lamps are less than 750mm above the ground)	A “E” or “e”
Rear Position Lamps	Min 2 Max Any number (Includes optional lamps)	Mandatory	Red	400	1500 or if impractical 2100	350	a. Horizontal i. 45° Inwards ii. 80° Outwards b. Vertical i. 15° above and below the horizontal (May be reduced to 5° if the lamps are less than 750mm above the ground)	R “E” or “e”
Stop Lamps	Min 2 Max Any number (Includes optional lamps)	Mandatory	Red	One on each side of longitudinal axis (Min separation 600mm. 400mm if the overall width of vehicle is less than 1,300mm)	1500 or if impracticable 2100	350	a. Horizontal i. 45° inwards and outwards b. Vertical i. as rear position lamps.	S1 or S2 “E” or “e”

End-outline, Position (Side), Stop, Side Marker & Daytime Running Lamps 22

TYPE	NUMBER	APPLICATION	COLOUR	POSITION			ANGLES OF VISIBILITY (see Figures 1 & 2 of Section 20)	APPROVAL MARK "E" or "e" Identity Symbol or BS Mark
				MAX DISTANCE FROM SIDE (mm)	MAX HEIGHT (mm)	MIN HEIGHT (mm)		
Stop Lamps (Optional)	Min 1 Max Any number	Optional	Red	If 1 is fitted: as close to vehicle centre-line as practicable If 2 are fitted: no requirement	N/A	No lower than the mandatory stop lamps	Must face the rear	S1 or S2 S3 or S4 for High Level "E" or "e"
End Outline Marker Lamp	Min 2 visible from the front and 2 visible from the rear Max Any number Includes optional lamps	Mandatory for vehicles exceeding 2.10m in width	Front-White Rear - Red	As close as possible to the extreme edge and not more than 400mm from the edge	-	Front The top of the lens no lower than the upper part of the windscreen meeting the light transmission requirements Rear As high as possible, compatible with the design and operational requirements and where structure exists to mount the lamps on	a. Horizontal i. 80° Outwards b. Vertical i. 5° Above the horizontal ii. 20° Below the horizontal	A or R "E" or "e"

End-outline, Position (Side), Stop, Side Marker & Daytime Running Lamps 22

TYPE	NUMBER	APPLICATION	COLOUR	POSITION			ANGLES OF VISIBILITY (see Figures 1 & 2 of Section 20)	APPROVAL MARK "E" or "e" Identity Symbol or BS Mark
				MAX DISTANCE FROM SIDE (mm)	MAX HEIGHT (mm)	MIN HEIGHT (mm)		
Side Marker Lamp	(see below)	All vehicles where the length exceeds 6m	Amber (The rearmost marker may be red if it is combined with another rear lamp)	-	1500 or if impracticable 2100	250	a. Horizontal i. 45° to the front and rear (Can be reduced to 30° if fitted as an optional extra) b. Vertical i. 10° Above and below the horizontal (The vertical angle below the horizontal may be reduced to 5° if the side marker lamp is fitted less than 750mm from the ground)	SM1 (SM2 for optional lamps only) "E" or "e"
Daytime Running Lamp (Optional)	Min 2 Max 2	Optional	White	400mm	1500mm	250mm	a. Horizontal i. 20° Outwards and inwards b. Vertical i. 10° Upwards and downwards	"E" or "e"

Side Marker Lamp Spacing

- at least one side-marker lamp must be fitted to the middle third of the vehicle
- the foremost side-marker lamp being not further than 3m from the front
- the distance between two adjacent side-marker lamps shall not exceed 3m, if the structure of the vehicle makes it impossible to comply with such a requirement, this distance may be increased to 4m
- the distance between the rearmost side-marker lamp and the rear of the vehicle shall not exceed 1m.

Symmetrical requirements for Position and End Outline Marker Lamps

In addition to the positional requirements in Table 1, the lamps specified when fitted as pairs should be positioned symmetrically where practicable and where structure exists, fitted one on each side of the vehicle at the same height above the ground, and at the same distance from the extreme outer edge of the vehicle.

End-outline, Position (Side), Stop, Side Marker & Daytime Running Lamps 22

Record of Revision

Revision	Date	Description of Change
1	24/04/2009	
2	16/08/2010	Add link for notes to RS6, 11 and 20
3	31/01/2011	Amend Table 1
4	30/04/2012	Amend Table 1 (End Outline Markers)
5	29/10/2014	New note 3, old Notes 3 – 5 now 4 - 6
6	01/09/2015	Amend table 1 regarding stop lamp lateral position
7	10/04/2018	Reorder notes & Addition of Note 7
8	01/09/2020	Correct front outline lamp positional requirements in Table 1.
9	20/10/2023	New Note 7 and renumbering of existing Notes. (TSE IVA N2 N3 022 008).
10	28/11/2025	Clarify height requirements in Table 1 for End outline marker lamps (TSE IVA N2N3 022 008). Add footnote to Table 1 detailing symmetrical requirements for Position and End Outline Marker Lamps (TSE N2N3 020 013). Improved format of Table 1. Clarification of requirements for optional side marker lamps in Note 3. SM2 added as applicable marking for optional side marker lamps in Table 1.
11	11/05/2026	New Note 8 referenced from RS21 header. Previous Note 8 renumbered to Note 9, reformatted, and referenced from RS25 (TSE IVA N2N3 022 011).

End-outline, Position (Side), Stop, Side Marker & Daytime Running Lamps 22

This page intentionally left blank

End-outline, Position (Side), Stop, Side Marker & Daytime Running Lamps 22

23 Direction Indicators

Application: All Vehicles

Method of Inspection	Required Standard
<p>Carry out a visual check of all direction indicator and side repeater lamps fitted to the vehicle for operation, colour, number, approval markings and correct positioning.</p> <p>With optional lamps check that fitment is permitted and they do not exceed the maximum number of lamps allowed to be fitted.</p> <p>The inspection of hazard warning lamps applies to all the obligatory direction indicator and side repeater lamps fitted to the vehicle.</p> <p>Two additional lamps may be fitted to a STGO - Abnormal Indivisible Load Vehicles (GTW of at least 120,000kg).</p> <p>In addition to the Required Standards, vehicles MAY have EITHER of (1) or (2) below:</p> <p>(1) Direction indicator side repeater lamps Three category 5 side repeaters distributed as evenly as practicable along each side</p> <p>OR</p> <p>(2) Flashing Side marker lamps. Mandatory amber side marker lamps may flash simultaneously with the direction-indicator lamps on the same side of the vehicle.</p> <p>Only one of the above specific combinations is allowed, no other combination is acceptable.</p>	<p>Directional Indicators</p> <ol style="list-style-type: none"> 1. All lamps must be 'e' or 'E' marked and where applicable, bear the appropriate identity marking as listed in table 1. 2. They must be operational. 3. The correct number must be fitted to the vehicle (Table 1). 4. The indicators must flash at a rate of between 60 and 120 times a minute (with all mandatory indicators working, and with the engine running if initially below the requirement). 5. There must be an audible or visual tell-tale fitted to indicate the non-operation of any indicators. 6. All indicators must emit amber light. 7. They must be positioned to meet (see Note 1) <ol style="list-style-type: none"> a. the positional requirements of Table 1 b. the angles of visibility requirements of Table 1 <p>Hazard Warning Lights</p> <ol style="list-style-type: none"> 8. They must operate with the ignition switched on and off. 9. The hazard warning device must operate all of the direction indicators simultaneously.

Direction Indicators 23

Method of Inspection	Required Standard
<p>Where (2) above is used, there is NO requirement for the side marker lamps to be marked in addition as side repeater lamps.</p> <p>Note 1: Geometric angles of visibility and positional requirements are not required for all optional direction indicator lamps.</p> <p>Note 2: Two additional lamps may be fitted to a special purpose vehicle designed for use with equipment that may obstruct the mandatory devices. Where additional dipped beam headlamps are fitted using the waiver in Note 4(b) to section 25, these additional indicator lamps may be mounted at a similar height to the dipped beam headlamps.</p>	<p>10. The hazard warning device must have a tell-tale warning light fitted which is circuit specific.</p>

Table 1

TYPE	NUMBER	APPLICATION	COLOUR	POSITION			ANGLES OF VISIBILITY See Figures 1 & 2 of section 20	APPROVAL MARK “E” or “e” Identity Symbol or BS Mark / Notes
				MAX DISTANCE FROM SIDE (mm)	MAX HEIGHT (mm)	MIN HEIGHT (mm)		
Direction Indicators & Hazard Warning	<p>Motor Vehicles On each side</p> <p>Front – One (see Mol for SPV and STGO AIL concessions)</p> <p>Rear – One Plus 2 optional all vehicles- Rear only</p> <p>Side Repeater – One</p> <p>Optional Up to 3 (category 5) or 1 (Category 6) if vehicle over 9m in length</p>	All Vehicles	Amber	<p>400</p> <p>(Min separation 600 unless vehicle width is less than 1300, where min separation 400)</p>	<p>1500 or if impracticable 2300 for side direction indicators and 2100 for front and rear direction indicators (see Note 2)</p>	<p>Side indicators 500</p> <p>Other indicators 350</p>	<p>a. Horizontal</p> <p>i. 80° outwards 45° inwards.</p> <p>ii. (SIDE REPEATER) To the rear between 5° and 60° outboard.</p> <p>b. Vertical</p> <p>i. < 750mm above the ground 15° above and 5° below horizontal.</p> <p>ii. Otherwise 15° above and below horizontal.</p>	<p>Front 1, 1a, 1b or 11</p> <p>Front – side 3 or 4</p> <p>Side Repeater 5 or 6</p> <p>Rear 2a, 2b or 12</p> <p>“E” or “e”</p>
A side repeater lamp must be fitted within 2600 mm of the front of the vehicle								

Direction Indicators 23

Record of Revision

Revision	Date	Description of Change
1	24/04/2009	
2	16/08/2010	Add note 1 and link to RS7
3	29/10/2014	New Notes 2 & 3 added with link from Table 1
4	01/09/2015	Amendment to Note 2
5	10/04/2018	Mol added regarding extra side repeaters/flashing side marker lamps
6	01/09/2020	Table 1 clarified.
7	20/10/2023	Revision of Mol including new Note 2 referenced from Table 1 (Special purpose vehicles).

24 Rear Registration Lamps

Application: All Vehicles

Method of Inspection	Required Standard
<p>Carry out a visual check of all rear registration plate lamps fitted to the vehicle for operation, colour, and correct positioning.</p> <p>Note 1: See section 4 Rear Registration Plate Space in conjunction with position of rear registration plate lamp.</p>	<p>Rear registration plate lamps</p> <ol style="list-style-type: none"> 1. All lamps must be 'e' or 'E' marked. 2. They must be operational. 3. They must be able to be switched on and off with the front and rear position lights by operating one switch. 4. They must only emit white light. 5. They must be positioned sufficient to illuminate the rear registration plate (see Note 1).

Record of Revision

Revision	Date	Description of Change
1	24/04/2009	
2	31/01/2011	Remove the optional requirement
3	31/07/2011	Add new RS1 and renumber remaining standards
4	01/09/2020	Note numbered and linked to RS5.

25 Headlamps

Application: All Vehicles

Method of Inspection	Required Standard
<p>Carry out a visual check of all headlamps fitted to the vehicle for operation, colour, number, approval markings and correct positioning.</p> <p>With optional lamps check that fitment is permitted and they do not exceed the maximum number of lamps allowed to be fitted.</p> <p>Where vehicles are fitted with Gas Discharge or LED Headlamps there is no requirement for headlamp cleaning if the light output is below 2000 Lumens (evidence must be provided).</p> <p>In the case of a dipped beam headlamp the minimum height is measured to the lower edge of the light emitting surface.</p> <p>Note 1: The “Main Beam” tell-tail can be either blue in colour, or a tell-tale (any colour but preferably blue) with the symbol (see section 33) or a tell-tale any colour and the words Main Beam or Main.</p> <p>Note 2: The alignment requirement must be met without the use of masks or beam converters unless they are an integral part of the headlamp as it was approved. Devices or materials applied to the inside of a headlamp which were not present at the time of approval are unacceptable.</p> <p>Some vehicles may be fitted with an in-car driver’s headlamp adjustment device. This may be adjusted to enable both headlamps to meet the criteria. Both</p>	<p>Headlamps</p> <ol style="list-style-type: none"> 1. All lamps must be ‘e’ or ‘E’ marked and where applicable, bear the appropriate identity marking as listed in table 1. 2. They must be operational. 3. All obligatory and optional headlamps must be fitted as “matched pairs”. 4. They must emit a white light. 5. When on dip or main beam they must emit sufficient light to be able to illuminate the road in front of the vehicle. 6. The correct number must be fitted to the vehicle (Table 1). 7. Dipped beam headlamps must be positioned to meet the requirements of Table 1. 8. There must be a tell-tale when on main beam (see Note 1). <p>Gas Discharge and L.E.D Headlamps</p> <ol style="list-style-type: none"> 9. Must be accompanied by evidence of compliance with the technical requirements if not compliant with the following: <ul style="list-style-type: none"> • is "E" or "e" marked • dipped beam remains on when main beam is on (gas discharge only) • is fitted with a wash system • is fitted with an automatic headlamp self-levelling system or self-levelling suspension.

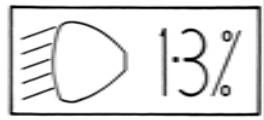
Method of Inspection	Required Standard
<p>headlamps, however, must comply with the requirements with the device set in one position.</p> <p>Align the headlamp aim testing equipment to the vehicle in accordance with the manufacturer's instructions. With an assistant sitting in the driver's seat, check the alignment of each dipped beam headlamp in association with the appropriate criteria.</p> <p>Note 3: Example of marking showing the vertical downwards inclination of the dipped-beam headlamps when the vehicle is at its kerbside weight and has a weight of 75 kg on the driver's seat.</p>  <p>Note 4: Two additional dipped beam headlamps forming a matched pair with electrical connections that permit only one pair to operate at any one time and fitted to:</p> <p>(a) a vehicle intended for use in both left hand and right-hand rule of the road traffic and in which case one pair must meet the requirements for right hand rule of the road traffic; or</p> <p>(b) a special purpose vehicle designed for use with equipment that may obstruct the mandatory devices and mounted higher than the mandatory devices but as low as practicable whilst ensuring maximum geometric visibility, notwithstanding that in some positions of movable equipment, the headlamp may be obscured. Headlamps fitted by the OEM should be considered to comply with this requirement. The aim of the lamps only needs to be assessed visually to check that they illuminate the road directly in front of the vehicle.</p>	<p>Headlamp Aim (see Note 2)</p> <p>European Type (checked on dipped beam)</p> <ol style="list-style-type: none"> 10. The beam image 'kick-up' must not be to the offside. 11. For headlamps with centres not more than 850mm from the ground, the beam image horizontal cut-off must be between the horizontal 0.5% and 2% lines, i.e., the red tolerance band. 12. For headlamps with centres more than 850mm from the ground, the beam image horizontal cut off must be between the horizontal 1.25% and 2.75% lines, i.e., the blue tolerance band (see Note 4). 13. The beam image 'break point' must not be to the right of the 0% vertical line, or to the left of the vertical 2% line. 14. The vehicle must be marked with a clearly legible and indelible marking showing the setting recommended by the manufacturer for the downward inclination of the horizontal part of the cut-off of the beam pattern of the dipped-beam headlamps, and that setting shall be a single figure - (see Note 3). <ol style="list-style-type: none"> a. between 1 and 1.5 per cent if the height of the centre of the headlamp is not more than 850 mm above the ground, and b. between 1 and 2 per cent if the height of the centre of the headlamp is more than 850 mm above the ground.

European Type Headlamp

Checked on Dipped Beam

Check the position of the 'break point' and horizontal cut-off.

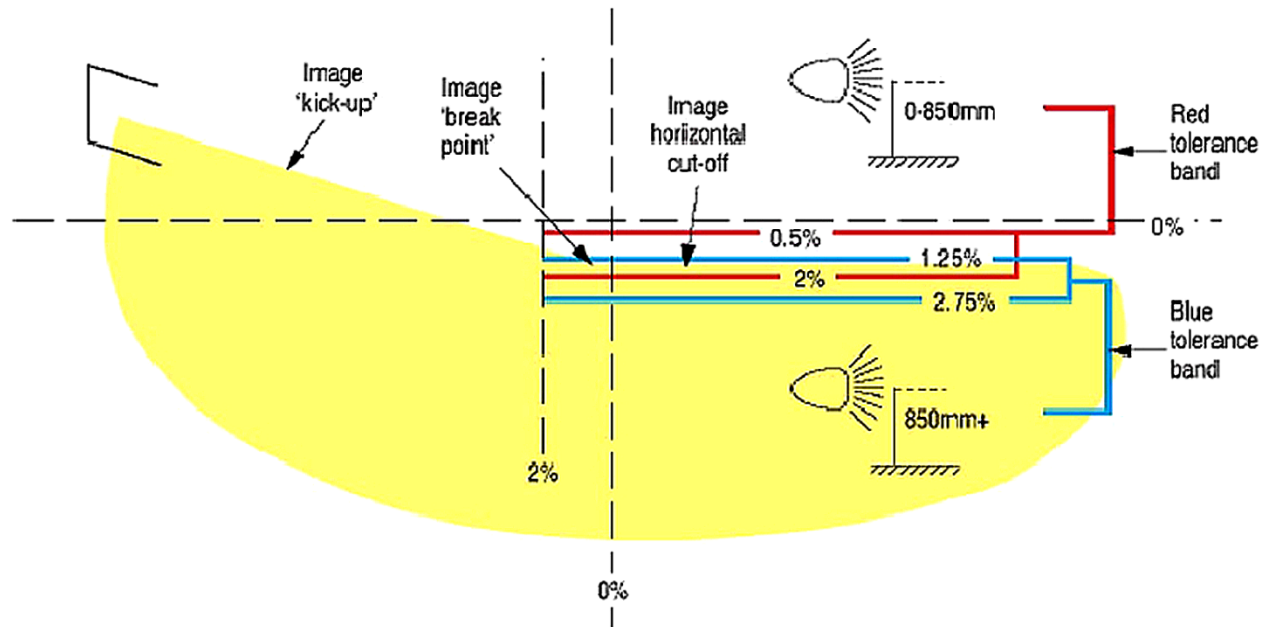

Table 1

TYPE	NUMBER	APPLICATION	COLOUR	POSITION			ANGLES OF VISIBILITY See Figures 1 & 2 of section 20	APPROVAL MARK "E" or "e" Identity Symbol or BS Mark / Notes
				MAX DISTANCE FROM SIDE (mm)	MAX HEIGHT (mm)	MIN HEIGHT (mm)		
Dipped Beam Headlamp	Min 2 Max 2 (see Note 4 above)	Motor Vehicles	White	400	1200 (1500 if N3G)	500 (see Note 2)	Angles of Visibility: 45° out 10° in 15° up 10° down	C "E" or "e"
Main Beam Headlamp	Min 2 Max 4	Motor Vehicles	White	May be in the same lamp assemblies as dipped beam	-	-	No requirement	R "E" or "e"

Record of Revision

Revision	Date	Description of Change
1	24/04/2009	
2	16/08/2010	Link notes to RS
3	31/01/2011	Renumber standards
4	31/07/2011	Add L.E.D requirement
5	29/10/2014	New Note 2 added, link from Table 1, old Notes 2 & 3 now 3 & 4
6	10/04/2018	Add RS 8 & Note 1, add RS14, & Note 5, amend MOI headlamp wash, renumber notes
7	01/07/2018	Add Note 4 & reformat MOI
8	01/09/2020	Note 4 expanded and linked to RS12.
9	20/10/2023	Revision of Note 4(b) additional dipped beam headlamp height requirements for special purpose vehicles
10	11/05/2026	Maximum height updated to include N3G.

This page intentionally left blank

26 Front Fog Lamps

Application: All Vehicles (Optional)

Method of Inspection	Required Standard
<p>Carry out a visual check of all front fog lamps for operation, colour, number, approval markings and correct positioning.</p> <p>Note 1: When changing from dipped to main beam the front fog lamps may be extinguished and may be switched back on when changing back from main-beam to dipped-beam.</p>	<p>Front fog lamps</p> <ol style="list-style-type: none"> 1. All lamps must be 'e' or 'E' marked and, where applicable, bear the appropriate identity marking as listed in Table 1. 2. The correct number must be fitted to the vehicle (Table 1). 3. They must be operational. 4. They must be able to be switched on only when the position lights are on and must operate independently of the dipped and main beam headlamps. (see Note 1). 5. They must only emit white or yellow light. 6. They must be positioned correctly to meet the positional requirements of Table 1.

Table 1

TYPE	NUMBER	APPLICATION	COLOUR	POSITION			ANGLES OF VISIBILITY See Figures 1 & 2 of section 20	APPROVAL MARK "E" or "e" Identity Symbol or BS Mark / Notes
				MAX DISTANCE FROM SIDE (mm)	MAX HEIGHT (mm)	MIN HEIGHT (mm)		
Front Fog Lamps	Two (Maximum)	Optional	White or Yellow	400	1200 (1500 if N3G but no higher than the top edge of the dipped beam headlamp)	250	Not Applicable	B "E" or "e"

Record of Revision

Revision	Date	Description of Change
1	24/04/2009	
2	10/04/2018	Add Note 1 & amend RS4
3	01/09/2020	Max height amended to match UN Reg 48.03.

This page intentionally left blank

27 Towing Hooks

Application: All Vehicles

Method of Inspection	Required Standard
<p>The vehicle must be equipped with a device at the front that enables the vehicle to be towed that can withstand a tractive and compressive static force of at least half the authorised total weight of the vehicle.</p> <p>The device may be in the form of a fixed or screw-in eyelet, welded loop, a holed metal plate, or may be incorporated into the vehicle structure. Removable / retractable towing device eyes or loops will need to be placed into the 'towing position' to be assessed.</p> <p>Where a vehicle has been adapted and the special purposes make it impossible to fully comply, the manufacturer shall demonstrate to the satisfaction of the approval authority that the vehicle cannot meet the requirements due to its special purpose.</p> <p>Note 1: Where visually the device or surrounding structure does not appear to be of sufficient strength, the presenter shall provide evidence from the manufacturer of the vehicle and/or the device to the requirements of this section.</p> <p>Note 2: In the case of an STGO vehicle this would relate to the GVW of the tractive unit and not the combination (total weight).</p>	<ol style="list-style-type: none"> 1. The vehicle must have a suitable towing device on the front of the vehicle to allow the attachment of a rigid towing bar. 2. Any towing hook or eye, mounting arrangement, bracket, or surrounding vehicle structure must be able to withstand the loads expected (see Notes 1 & 2).

Record of Revision

Revision	Date	Description of Change
1	24/04/2009	
2	16/08/2010	Add SPV statement
3	31/01/2011	Remove the reference to rope in RS 1
4	01/09/2015	Addition of Note 2

28 Rear Fog Lamps

Application: All Vehicles

Method of Inspection	Required Standard
<p>Carry out a visual check of the rear fog lamps fitted to the vehicle for operation, colour, number, approval markings and correct positioning.</p> <p>With optional lamps check that fitment is permitted and they do not exceed the maximum number of lamps allowed to be fitted.</p> <p>Rear Fog Lamp separation distance must be measured between the “illuminating surface” of each lamp (See table 1).</p> <p>Note 1: For Crash Cushion Vehicles the maximum does not apply due to the configuration of lamps fitted to the boom.</p> <p>Note 2: Front fog lamps may be illuminated with the side lamps only.</p> <p>Note 3: Either of the following scenarios will also be considered acceptable:</p> <ul style="list-style-type: none"> • The rear fog lamp(s) may continue to operate until the position lamps are switched off, and the rear fog lamp(s) must then remain off until deliberately switched on again, or • A warning, at least audible, additional to the mandatory tell-tale light shall be given if the ignition is switched off or the ignition key is withdrawn and the driver's door is opened, whether the lamps in (RS4) are on or off, whilst the rear fog lamp switch is in the "on" position. 	<p>Rear fog lamps</p> <ol style="list-style-type: none"> 1. All lamps must be ‘e’ or ‘E’ marked and where applicable, bear the appropriate identity marking as listed in table 1. 2. They must be operational. 3. The correct number must be fitted to the vehicle (Table 1 and Note 1). 4. The rear fog lamp(s) must only illuminate when dipped beam, main beam or front fog lamps are lit (See alternatives in Notes 2 & 3). 5. The rear fog lamps must not be affected by switching on or off any other lamps (except those above). 6. Can be switched off independently of any other lamp, and either: <ol style="list-style-type: none"> a. may continue to be operated until the position lamps are switched off and then must remain off until deliberately switched back on, or b. a warning, at least audible, additional to the mandatory tell-tale is given if the ignition is switched off or the ignition key is withdrawn, and the driver's door is opened whilst the rear fog lamp switch is in the 'on' position. 7. They must only emit a red light. 8. They must be positioned correctly to meet: <ol style="list-style-type: none"> a. the positional requirements of Table 1 (see Note 4) b. the angles of visibility requirements of Table 1

Rear Fog Lamps 28

Method of Inspection	Required Standard
<p>Note 4: Refuse vehicles of the type loaded from the rear with a Powerlink boom are to be considered as vehicles with a special construction requirement. Where it is determined that the rear fog lamp(s) cannot be positioned to meet the prescribed height requirements, the rear fog lamp(s) may be fitted at an alternative height appropriate to the design of the vehicle.</p> <p>Note 5: When grouped with any rear lamp, the maximum height may be increased to 1200mm. For Categories N2G & N3G (off-road) vehicles, when not grouped with any rear lamp the maximum height may be increased to 1400mm.</p>	<p>9. Must be fitted with an operational “tell-tale” lamp (non-flashing) visible from the driving position.</p> <p>10. Must not be operated by a brake control.</p> <p>11. Fitted so that the reflector is facing squarely to the rear.</p> <p>12. Where two rear fog lamps are fitted, they must form a matched pair.</p> <p>13. Where two rear fog lamps are fitted, they must operate as a matched pair.</p>

Table 1

TYPE	NUMBER	APPLICATION	COLOUR	POSITION			ANGLES OF VISIBILITY See Figures 1 & 2 of section 20	APPROVAL MARK “E” or “e” Identity Symbol or BS Mark / Notes
				MAX DISTANCE FROM SIDE (mm)	MAX HEIGHT (mm)	MIN HEIGHT (mm)		
Rear Fog Lamp	Min 1 Max 2 (see note 1)	All Vehicles	Red	At least one must be on centre line or to offside of vehicle (Min separation distance from stop lamp 100mm)	1000 (see Note 5)	250 (see Note 4)	<p>a. Horizontal</p> <p>i. 25° inwards and outwards; if two lamps are fitted it is sufficient if one lamp (not necessarily the same lamp) – is visible throughout the range</p> <p>b. Vertical</p> <p>i. 5° above and below horizontal.</p>	B or F “E” or “e”

Rear Fog Lamps 28

Record of Revision

Revision	Date	Description of Change
1	24/04/2009	
2	29/10/2012	Amend maximum height requirement in Table 1
3	03/02/2014	Insert new note 2 and link to RS4,
4	29/10/2014	Note 1 replaced, link from Table 1
5	01/09/2015	Addition of Note 3
6	10/04/2018	Addition of Note 2 & 4 & reorder notes
7	28/11/2025	Revise Table 1 Max. Height column and add new Note 5 (TSE IVA N2N3 028 001)
8	11/05/2026	Note 4 revised & added reference from Table 1, 'Min height'.

This page intentionally left blank

29 Reversing Lamps

Application: All Vehicles

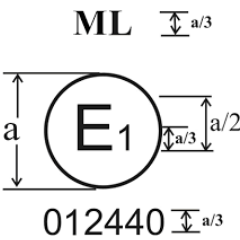
Method of Inspection	Required Standard
<p>Carry out a visual inspection of all reverse lamps fitted to the vehicle (including manoeuvring lamps, where applicable) to verify correct operation, colour, number, approval markings, and positioning (see Table 1).</p> <p>In addition, for all optional lamps, verify that their fitment is permitted and that the total number of lamps does not exceed the maximum allowed.</p> <p>‘Manoeuvring lamp’ means a lamp used to provide supplementary illumination to the side of the vehicle to assist during slow manoeuvres.</p> <p>Example of a manoeuvring lamp approval marking</p>  <p>Note 1: Geometric visibility is considered to be satisfied when the reference axis of the device is oriented outward at an angle not exceeding 15° relative to the vehicle’s median longitudinal plane. The vertical aim of the two optional devices may be directed downward.</p>	<p>Reverse lamps</p> <ol style="list-style-type: none"> All lamps must be ‘e’ or ‘E’ marked and, where applicable, bear the appropriate identity marking as listed in Table 1. They must be operational. The correct number must be fitted to the vehicle (Table 1). They must emit white light. They must be positioned to face the rear and meet the positional requirements of Table 1. They must operate by selection of reverse gear. <p>If the optional reverse lamps are fitted to the side of the vehicle and used for slow manoeuvres in a forward motion (see Note 1).</p> <ol style="list-style-type: none"> The devices must be activated and deactivated manually by a separate switch (see Note 2). They must be automatically switched off if the forward speed of the vehicle exceeds 15 km/h, regardless of the position of the separate switch. In this case they shall remain switched off until deliberately being switched on again. <p>Manoeuvring Lamps (if fitted) (see Notes 2 & 3)</p> <ol style="list-style-type: none"> They must meet the requirements of Table 1.

Reversing Lamps 29

Method of Inspection	Required Standard
<p>Note 2: The lamps may only be activated when the position lamps are switched on and one of the following conditions is met:</p> <ul style="list-style-type: none"> • reverse gear is engaged; • a camera-based parking assistance system is operating; or • the vehicle begins initial movement after activation of the propulsion system. <p>Note 3: The distance between two adjacent manoeuvring lamps on the same side must not be less than 0.5 m.</p>	

Table 1

TYPE	NUMBER	APPLICATION	COLOUR	POSITION			ANGLES OF VISIBILITY	APPROVAL MARK “E” or “e”, Identity Symbol, or BS Mark / Notes
				MAX DISTANCE FROM SIDE (mm)	MAX HEIGHT (mm)	MIN HEIGHT (mm)		
Reversing Lamps	Min 1 Max 2	All Vehicles up to 6000mm in length	White	-	1200	250	Visible from the rear (see Section 20, Figure 3) If optional lamps are fitted to the side of the vehicle: Outwards Maximum 15° relative to the median longitudinal plane (see Note 1)	A or R “E” or “e”
	Min 2 Max 4 (Includes optional lamps)	Vehicles with a length exceeding 6000mm in length						

TYPE	NUMBER	APPLICATION	COLOUR	POSITION			ANGLES OF VISIBILITY	APPROVAL MARK "E" or "e", Identity Symbol, or BS Mark / Notes
				MAX DISTANCE FROM SIDE (mm)	MAX HEIGHT (mm)	MIN HEIGHT (mm)		
Manoeuvring Lamps (if fitted)	1 or 2 (1 per side)	Vehicles < 6m in length	White	-	1500	-	See Section 20, Figure 3	ML "E" or "e"
	Max 4 (2 per side)	Vehicles over 6m ≤ 9m in length						
	Max 6 (3 per side)	Vehicles over 9m in length						

Record of Revision

Revision	Date	Description of Change
1	24/04/2009	
2	31/01/2011	Amend RS 5
3	03/02/2014	Amend number of lamps in Table 1
4	01/09/2015	Add new optional lamp requirements
5	28/11/2025	Revise RS6 (TSE IVA N2N3 029-003). Table 1 reformatted.
6	11/05/2026	Mol wording, Note 1 wording, header to RS7, & RS 7 revised. New Notes 2 & 3. Permitted speed at RS8 revised. RS9 added. Addition of manoeuvring lamps to Table 1.

31 Seat Belts

Application: All Vehicles

Method of Inspection	Required Standard
<p>Disabled persons belts Disabled person belts are seat belts which have been specially designed or adapted for use by an adult or young person suffering from some physical or mental impairment, intended for use solely by such a person and as such are exempt the requirements of this section, however the belt must be securely attached and appear to operate as intended.</p> <p>Seats not intended for road use (a) The requirements of this section do not apply to seats intended for use solely while the vehicle is stationary or for when the vehicle is not used on a public road. (b) Any seats which are not for use when travelling on a public road must be clearly identified to users by means of a pictogram or a sign with appropriate text.</p> <p>Where optional belts are fitted, they must comply with the requirements of this section.</p> <p>In the case of armoured vehicles exemption from any requirement of this section is permitted if it can be demonstrated to the satisfaction of the Approval Authority that it is impossible for the vehicle to comply due to its special purpose.</p> <p>Note 1: A suitable single bolt fixing of adequate strength would be, for example, a bolt of at least 11mm (7/16") diameter of grade 8.8 (the grade may not be shown on a bolt produced for a seat belt anchorage) Other bolt fixings may be acceptable providing they are of equivalent strength. Two adjacent seat belts may be secured by one bolt. In this case consideration must be given to the additional loads on the</p>	<ol style="list-style-type: none"> 1. Each seat requiring a seat belt must be fitted with a seat belt of the appropriate type. See Annex 1. 2. Each seat belt must bear an appropriate "e" approval mark. 3. Where seats are intended for use only when the vehicle is not being driven on public roads, the seats must be accompanied by a pictogram or sign clearly indicating that the seat is not to be used whilst the vehicle is in motion. 4. Each seat belt must be attached by an appropriate fixing and be securely fitted (see Notes 1 & 2). 5. There must be no damage to the seat belt structure that would affect its strength. 6. The lock mechanism must securely lock the belt. 7. The lock mechanism must be able to be released easily, both in normal use and when the belt is under load. 8. The retractor mechanism must be of an acceptable type and be correctly positioned to ensure the correct operation of the belt (see Notes 3 & 4). 9. With the seat belt fastened and the seat unoccupied, retractor mechanisms must take up any excess webbing (see Note 5).

Method of Inspection	Required Standard
<p>anchorage.</p> <p>Note 2: In order that a seat belt can be separated from the anchorage without causing damage to the anchorage, for example a mounting in the side of a tube or box section, it is a requirement that the bolt is secured into a “fixed” threaded hole or captive nut. (The presenter may be required to demonstrate this condition is met). The bolt may be secured into an alternative fixing, e.g., a lock nut of suitable strength, where access is provided to the “rear” of the mounting to enable separation/re-attachment of the belt.</p> <p>Note 3: A belt may be fitted with retractor mechanisms on both lap and diagonal sections. If fitted with a single retractor mechanism it must act initially on the diagonal (shoulder) section.</p> <p>Note 4: An “automatically locking” retractor (i.e., one that allows extension of the belt to the desired length and when the buckle is fastened locks on retraction but then prevents subsequent forward movement by the wearer, unlike a typical inertia reel belt), is not permitted unless the feature is only provided after full extension of the belt from the retractor, i.e., for use as a child restraint.</p> <p>Note 5: Some types of retracting belt might need assistance in order to retract.</p> <p>Note 6: Where a seat belt is not integral with the seat as approved, check that whilst sitting in each seat in turn, and wearing the seat belt, secured and correctly adjusted, that the position of the webbing on the torso and the location of the effective belt anchorage points in relation to the seated body position are correct.</p> <p>Note 7: The seat belt must be capable of effectively restraining the occupant.</p> <ul style="list-style-type: none"> ▪ by the position of the lap belt (due to anchorage location) passing over the pelvic region 	<ol style="list-style-type: none"> 10. The seat belt must sit correctly across the wearers torso so as to provide effective restraint in the event of a frontal impact (see Notes 3, 4, 6, 7, & 8). 11. There must not be any sharp edges / objects in the seat belt area likely to cause damage to the belt. 12. Where an airbag is fitted in front of a passenger position, a warning label for the airbag must be permanently fixed to the vehicle. 13. The warning label for the airbag must be visible in front of a person about to install a rearward facing child restraint. <div style="text-align: center;">  </div> <ol style="list-style-type: none"> 14. The warning label for the airbag must be visible when the door is closed otherwise a permanent reference elsewhere that is visible at all times is required. 15. A harness or three-point belt “effective upper anchorage” location must be at least 450mm above the reference point. (see Note 9 and figure 1). 16. A lap/diagonal belt “effective upper anchorage” location must be at least 140mm from the longitudinal centre line of the seat. (see Note 9).

Method of Inspection	Required Standard
<ul style="list-style-type: none"> ▪ in the case of a harness belt or three-point belt, by being positioned across the shoulder so that it does not slip off the shoulder of the occupant. <p>Note 8: Where the seat is adjustable, this check must be carried out with the seat secured in the rearmost position and with the back rest in the normal driving position, in any case at a rearward angle of not more than approximately 25° from the vertical.</p> <p>Note 9: The effective belt anchorage is the actual anchorage point to the vehicle unless a change of direction of the belt to the wearer is produced by a fixed intermediate device, for example, a belt guide fitted to the upper part of a seat back, consideration should be made to the suitability of the seat to withstand the loads likely to be imposed. The requirements Section 19 RS 3 apply to the effective anchorage location.</p> <p>Note 10: Seats may vary by only 10 degrees from either the forward or rearward facing direction before they become side facing.</p>	<p>17. The lower anchorages must be at least 350mm apart.</p> <p>18. The lower anchorages on side facing seats must be at least 350mm apart but no further apart than 500mm (see Note 10).</p>

Annex 1

Seat Belts – Minimum Obligatory Requirements (see Table Note 3)

Vehicle category	Front facing					Rear facing Seat	Side facing Seat
	Outboard Seat (Table Note 4)			Centre Seat			
	Driver	Front	Other	Front	Other	Other	All
N2	3 Point retractor belt or Lap belt	3 Point retractor belt or Lap belt	2 Point lap belt	2 Point lap belt see note 1 below	2 Point lap belt	None	None
N3	3 Point retractor belt or Lap belt	3 Point retractor belt or Lap belt	None	2 Point lap belt see note 1 below	None	None	None
Age-related IVA 1/4/1987 to 30/9/2001	None	None	None		None	None	None
From 30/9/2001	3 Point retractor belt or Lap belt	3 Point retractor belt or Lap belt	None	2 Point lap belt see note 1 below	None	None	None

TABLE NOTE 1: As determined by Annex 2 the front centre seat will require 3 anchorages and a 3-point belt where the windscreen is located

- in the case of a fixed (non-sliding) seat, within 840mm. of the seat reference point
- in the case of a sliding seat, within 840mm. of the seat reference point when the seat is 127mm forward of its rearmost position.

TABLE NOTE 2: '3 point belt' means a seat belt which:

- restrains the upper and lower parts of the torso
- includes a lap belt and a retractor that operates on the diagonal part
- is anchored at not less than three points, and
- is designed for use by an adult.

TABLE NOTE 3: The table lists the minimum required belt type. A 3-point retractor belt may be fitted where the minimum required is a 2-point lap belt and an acceptable alternative to any of the seat belt types listed is an adult harness belt comprising a lap belt and shoulder straps providing the anchorages satisfy section 19

TABLE NOTE 4: Outboard seats are seats closest to the vehicle sides and front seats are those foremost in the vehicle.

Figure 1

Effective Anchorage Upper Height Measurement

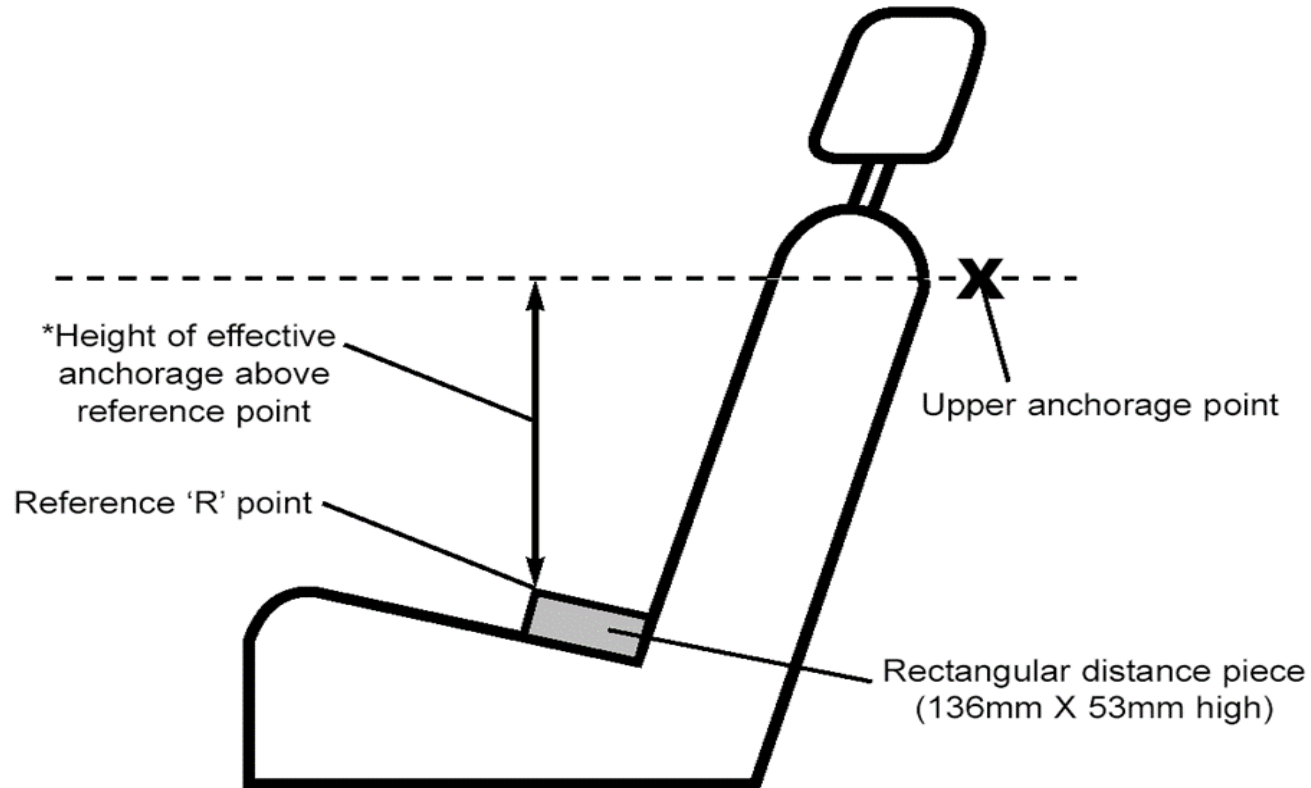
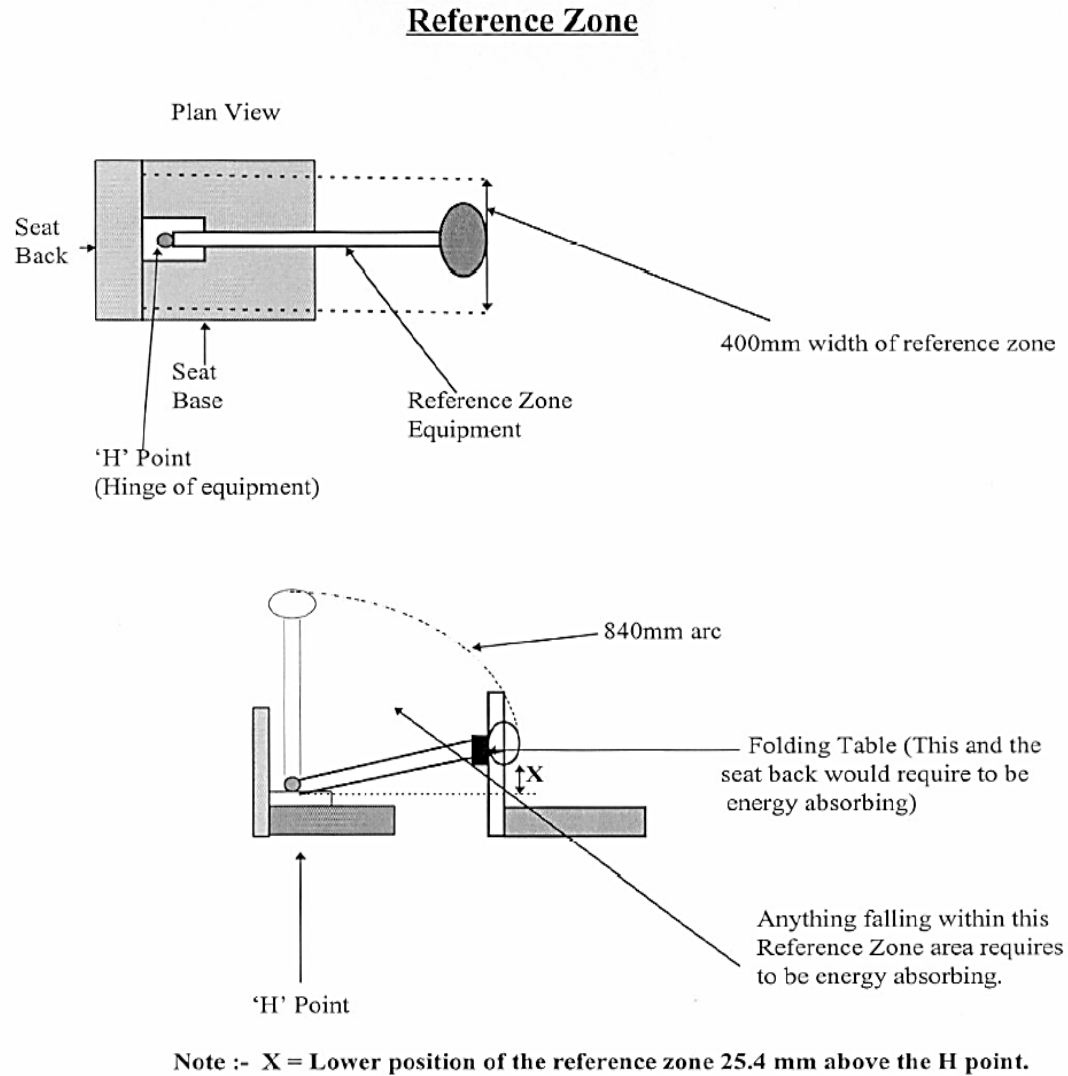

Figure 2 Determination of Reference Zone



Record of Revision

Revision	Date	Description of Change
1	24/04/2009	
2	16/08/2010	Add notes and link to Annex 1
3	31/01/2011	Amend Table in Annex 1 to list dates for age-related IVA (up to 25 year old vehicles)
4	31/07/2011	Amend Table in Annex 1 to list dates for age-related IVA (up to 25 year old vehicles)
5	30/04/2012	Add seat belt requirements to Table in Annex 1
6	29/10/2014	Add seat belt requirements for rear seats to Table in Annex 1
7	01/09/2015	Amendment to annex 1 table
8	10/04/2018	Amend MOI

This page intentionally left blank

33 Identification of Controls

Application: All Vehicles

Method of Inspection	Required Standard
<p>This inspection is to ensure that any controls, tell-tales, and indicators fitted to the vehicle are readily identifiable, useable and of the correct colour.</p> <p>Where a control, tell-tale or indicator are combined, a common symbol may be used for such a combination.</p> <p>Note 1: A control means that part of a device which enables the driver to bring about a change in the state or functioning of the vehicle.</p> <p>An indicator means a device which presents information on the functioning or situation of a system or part of a system. e.g., fluid level.</p> <p>A tell-tale means an optical signal which indicates the actuation of a device, correct or defective functioning or condition, or failure to function.</p> <p>Note 2: Symbols as shown in Table A, these symbols may differ slightly as long as they cause no confusion to the driver.</p> <p>Note 3: Controls, tell-tales and indicators listed in Table B are not required to be marked. However, present symbols must conform to those listed. These symbols may differ slightly as long as they cause no confusion to the driver.</p> <p>Note 4: Other controls, tell-tales and indicators may be marked provided there is no confusion with those marked in accordance with those on Table A or B.</p>	<p>Symbols as shown in Table A and B</p> <ol style="list-style-type: none"> 1. The controls, tell-tales and Indicators must be identified with the correct symbols and the stated colour (see Notes 1, 2, 3 & 4). 2. They must be on or close to the controls, tell-tales, and indicators. 3. They must stand out clearly from the background. 4. The vehicle must not be fitted with other controls, tell-tales and indicators that have symbols that may be confused with the symbols listed in Tables A and B (see Note 5). 5. All symbols must contrast with the background and be identifiable by the driver. 6. All driver controls must be able to be operated from the driver's seat. <p>Information Display Device Fitted (See Note 5)</p> <ol style="list-style-type: none"> 7. It must be able to display simultaneously the warning symbols for brake, main beam, and direction indicator. 8. It must provide the relevant information regarding tell – tales and indicators whenever the situation that causes them to operate arises.

Identification of Controls 33

Method of Inspection	Required Standard
Note 5: An information display device is a device capable of displaying more than one type of message or information. The requirements regarding colour do not apply to tell-tales and indicators appearing on the Information Display Device.	9. Must repeat automatically in sequence or indicate in such a manner that it is visible to and identifiable to the driver when two or more messages are given.

Table A



































Control, Tell-tale or Indicator	Symbol	Warning light / tell - tale	Control, Tell-tale or Indicator	Symbol	Warning light / tell - tale	Control, Tell-tale or Indicator	Symbol	Warning light / tell - tale
Master Light		Green	Direction Indicators		Green	Ventilating fan		
Dipped Beam Headlamps		Green	Hazard Warning		Red	Diesel Pre-heat		Yellow
Main Beam Headlamps		Blue	Windscreen Wiper			Choke (cold starting device)		Yellow
Position (side) Lamps		Green	Windscreen Washer			Brake Failure		Red
Front Fog lamps		Green	Windscreen Wiper and Washer			Fuel Level		Yellow
Rear Fog Lamps		Yellow	Headlamp Cleaning Device (with separate operating control)			Battery Charging Condition		Red
Headlamp Levelling device			Windscreen demisting and defrosting (when separate)		Yellow	Engine Coolant temperature		Red
Parking Lamps		Green	Rear Window demisting and defrosting (when separate)		Yellow			

Table B

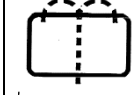
Control, Tell-tale or Indicator	Symbol	Notes	Warning light / tell - tale	Control, Tell-tale or Indicator	Symbol	Warning light / tell - tale
Parking Brake		Where a single tell-tale indicates more than one brake system condition, except brake anti-lock system failure, the symbol for brake failure must be used.		Horn		
Bonnet		Outline only may be used.		Rear Window Wiper		
Boot		Outline only may be used.		Rear window Washer.		
Seat Belt		Outline only may be used.	Red	Rear Window Wiper and washer.		
Engine Oil Pressure			Red	Intermittent Windscreen wiper.		
Unleaded Petrol						

Record of Revision

Revision	Date	Description of Change
1	24/04/2009	
2	16/08/2010	Add the word "and" to RS1, link notes to RS.
3	31/01/2011	Add new note 2 and renumber following notes.

This page intentionally left blank

34 Defrost / Demist

Application: All Vehicles fitted with a Windscreen

Method of Inspection	Required Standard
<p>Ensure that the vehicle is fitted with a system/systems capable of defrosting and demisting the windscreen (at least the swept area) to allow the driver an adequate view of the road in front and forward of the nearside and offside of the vehicle.</p> <p>Note 1: The fitting of a device not permanently incorporated into the vehicle structure i.e., adhered to the windscreen or body surface shall not be considered as a “system fitted to the vehicle.”</p>	<ol style="list-style-type: none"> 1. The vehicle must be fitted with a system capable of defrosting / demisting at least the swept area of the windscreen (see Note 1). 2. A system using warm air to clear the screen must employ fan assistance and ducting to direct the air onto the screen, to ensure effective operation of the defrosting system under cold weather conditions. 3. An electrically heated screen must provide adequate heat and distribution to ensure effective operation.

Record of Revision

Revision	Date	Description of Change
1	24/04/2009	
2	16/08/2010	Link note1 to RS1

35 Wash / Wipe

Application: All Vehicles fitted with a Windscreen

Method of Inspection	Required Standard
<p>Vehicles shall be fitted with adequate windscreen washing and wiping devices. Ensure that with the wind screen wet and the engine running, all wipers continue to move automatically over an area of the windscreen sufficient to give the driver an adequate view of the road in front and forward of the nearside and offside of the vehicle.</p> <p>Note 1: A “cycle” is the forward and return movement of the windscreen wiper.</p> <p>Note 2: Intermittent operation windscreen-wiper systems may be used for the purposes of complying with the requirements of RS3 provided that one of the frequencies obtained when the main frequency is interrupted is not less than 10 cycles/minute.</p>	<ol style="list-style-type: none"> 1. The vehicle must be fitted with a windscreen washer and wiper system to give the driver an adequate view of the road. 2. All front wipers must continue to move automatically over the swept area of the windscreen. 3. All front wipers must have at least two sweep frequencies (see Notes 1 & 2). 4. All front wipers must return automatically to a position of rest which is at or beyond the outer edge of the swept area. 5. All front wipers must be capable of being lifted from the windscreen to allow for cleaning of the windscreen. 6. The windscreen washer system must provide enough liquid to adequately clear the windscreen in conjunction with the wipers. 7. The windscreen washer system must have a reservoir capacity of at least 1 litre.

Record of Revision

Revision	Date	Description of Change
1	24/04/2009	
2	16/08/2010	Remove and renumber standards
3	31/01/2011	Amend text in MOI

36 Heating Systems

Application: All Vehicles (Optional fitment)

Method of Inspection	Required Standard
<p>Heating Systems must be fitted as to present no danger to passengers or other persons.</p> <p>The heating System may be of the following types and one or more of each may be fitted:</p> <p>Heater using waste heat from water-cooled engine.</p> <p>Must comply with RS 1 and 2</p> <p>Combustion heater</p> <p>Note 1: Requires documentary evidence or an 'E' marked component, manufacturers fitting instructions, plus an Installation Check.</p> <p>Note 2 A permanent notice stating that the heating system must not be used, and the gas cylinder valve must be closed when the vehicle is in motion or words to that effect.</p>	<ol style="list-style-type: none"> 1. There must be no obvious fire risk associated with the heating system (e.g., flammable parts of the vehicle near to a source of heat or a likelihood of users placing objects liable to catch fire on a very hot surface). 2. There must be no obvious injury risk associated with the heating system (e.g., likelihood of users touching a very hot surface or hot water pipes). 3. If a combustion heater is fitted, then it must be accompanied by documentary evidence (see Note 1). <p>Combustion heater Installation Check</p> <ol style="list-style-type: none"> 4. It must be positioned so not likely to cause injury. 5. Utilising a liquid or gaseous fuel must be fitted according to the manufacturer's instructions (see Note 1). 6. A fuel filling point shared by the heater and the engine must have a notice fitted instructing that the heater must be shut down before refuelling. 7. The heater exhaust must be positioned so exhaust gases are not likely to enter the driver / passenger compartment. <p>LPG heating systems for stationary use only</p> <ol style="list-style-type: none"> 8. Permanent warning labels/pictograms must be attached (see Note 2):

Heating Systems 36

Method of Inspection	Required Standard
	<ul style="list-style-type: none"> a. on the compartment where portable LPG cylinders are stored, <p style="text-align: center;">and</p> <ul style="list-style-type: none"> b. in close proximity to the control device for the heating system.

Record of Revision

Revision	Date	Description of Change
1	24/04/2009	
2	16/08/2010	Reword RS6 and RS7
3	03/02/2014	Reformat Section
4	01/09/2015	Amendment to Note 1
5	10/04/2018	Add RS8 & change manual wording
6	28/11/2025	RS8 format corrected.

This page intentionally left blank

42 Lateral Protection

Application: All Vehicles

Method of Inspection	Required Standard
<p>A vehicle of category N2 or N3 is not required to be fitted with a separate lateral protection device, providing the sides of the vehicle are so designed and/or equipped that by their shape and characteristics their component parts together meet the requirements in Standards 2 to 18.</p> <p>On a vehicle fitted with extendible legs to provide additional stability during loading, unloading or other operations for which the vehicle is designed, the side guard may be arranged with additional gaps where these are necessary to permit extension of the legs.</p> <p>On a vehicle equipped with anchorage points for ro-ro transport, gaps shall be permitted within the side guard to accept the passage and tensioning of fixing lashings.</p> <p>Vehicles where the distance between centres of two consecutive axles is greater than 3 metres must be fitted with Lateral Protection unless listed below.</p> <p>Lateral protection fitted to an exempted vehicle must comply with projection and radius requirements. Exemption from compliance with dimensional requirements (excluding those in respect of increasing the overall width of the vehicle) will only be permitted where fitment of a device is not possible due to the design and construction of the vehicle.</p>	<ol style="list-style-type: none"> 1. Where the side of the body does not meet the requirements, a side guard device must be fitted. <p>Requirements for both body sides and separate devices</p> <p><u>Required area to be protected</u></p> <ol style="list-style-type: none"> 2. The device or body side must have its rearward edge extended to within 300mm of the tyre on the first rear axle (see Note 1 and figure 4). 3. The device or body side must have the front edge of the guard within 300 mm of the rear of the tyre on the front wheel (or second wheel if two front axles are fitted) (see Note 2 and figure 4). Where stabiliser legs are fitted see Note 2. 4. The device or body side must be within 350 mm of the body line (see Note 3). 5. The device or body side lower edge must be no higher than 550 mm from the ground. <p><u>Within the required area the following standards must be met</u></p> <ol style="list-style-type: none"> 6. The device or body sides must be constructed of a suitable material and must be of sufficient strength as to offer effective protection to unprotected road users (see Note 4). 7. The device or body side must have a smooth or horizontally corrugated surface (see Note 5). 8. Any external edges including corners must be rounded with a radius of at least 2.5mm

Lateral Protection 42

Method of Inspection	Required Standard
<p>Exempt Vehicles:</p> <ul style="list-style-type: none"> - Tractors for articulated vehicles. - Road sweepers (A vehicle fitted with specialised equipment for sweeping streets). - Car transporters (vehicles with more than one loading deck, designed to carry other vehicles loaded on from the rear) exempt where the chassis rails are on the extremities of the vehicle - Gulley emptiers, where fitting of a lateral protection device prevents the use of the suction tube (not merely hinders). - Vehicles specifically designed and constructed for a purpose where the fitment of a lateral protection device would prevent the use of that equipment fitted (not merely hinders). - A tank-vehicle that is a vehicle designed solely for the carriage of fluid substance in a closed tank permanently fitted to the vehicle and provided with hose or pipe connections for loading or unloading, shall be fitted with side guards which comply so far as is practicable with all the requirements of this section; strict compliance may be waived only where operational requirements make this necessary. - Vehicles designed and constructed for special purposes where it is not possible, for practical reasons, to fit lateral protection devices. <p>STGO Exempt Vehicles:</p> <ul style="list-style-type: none"> - Road Recovery Vehicles (RRV). 	<ol style="list-style-type: none"> 9. There must be no projecting brackets, bolt heads or similar protrusions (see Notes 6, 7 & 12). 10. The device or body side must be continuous in length (see Note 8). 11. The device or body side must not have the rearward end more than 30mm inboard from the outermost edge of the rear tyres over at least the last 250mm of the device / body (see figure 1). 12. Where the 300mm dimension required in standard 3 results in the forward edge of the guard being forward of the rear cab panel. The device or body side must be constructed so that the forward end is beneath the cab panel work. Where the vehicle cab is narrower than the body then the side guard may be angled to meet this requirement and be turned inwards through an angle of not more than 45 degrees (see Note 9). <p>Where equipment is incorporated into the lateral protection device</p> <ol style="list-style-type: none"> 13. The equipment must have a smooth substantially flat or horizontally corrugated outer surface (see Notes 5 & 12). 14. There must not be a gap of more than 25 mm between it and the guard or body side (see Note 2 and figures 3 & 5). 15. Where necessary the equipment must meet any required dimensional requirement as if it was part of the device. 16. There must be no projecting brackets or hinges unless sufficiently radiused from all aspects (see Note 6). 17. It must not have protruding bolt heads or similar projections (see Notes 6 & 12). 18. Any external edges and corners must be rounded with a radius of at least 2.5mm.

Method of Inspection	Required Standard
<p>- Engineering Plant: only where the fitment of a lateral protection device would prevent the use of specialist equipment fitted (not merely hinders).</p> <p>Note 1: The measurement is taken to a vertical plane extending from the surface of the tread closest to the guard or relevant body work.</p> <p>Note 2: A gap of 130mm either side of a crane / stabiliser leg is permitted (see Figure 5).</p> <p>Note 3: The term 'Body Line' refers to that part of the vehicle structure which is cut or contacted by a vertical plane tangential to the outer surface of the tyres, except in the following cases:</p> <ul style="list-style-type: none"> • Where the plane does not cut the structure of the vehicle: The upper edge must be level with the surface of the load-carrying platform OR 950 mm from the ground, whichever is the lesser. • Where the plane cuts the structure of the vehicle at a level more than 1.3 m above the ground: The upper edge of the side guard must not be less than 950 mm above the ground. <p>Note 4: "Unprotected Road users" means pedestrians, cyclists or motor cyclists using the road in such a way that they are liable to fall under the sides of the vehicle and be caught under the wheels.</p>	<p>Additional requirements for separate devices</p> <p>19. The device must be attached securely.</p> <p>20. The device must consist of at least one horizontal rail (see Note 3).</p> <p>21. Where more than one horizontal rail is used, the rails must be not more than 300mm apart.</p> <p>22. For N2 vehicles the horizontal rails must have a section height of at least 50 mm (see figure 2 A).</p> <p>23. For N3 vehicles the horizontal rails must have a section height of at least 100 mm (see figure 2 B).</p> <p>24. It must have a forward-facing edge of at least 100 mm.</p> <p>25. The side guard must be no more than 150mm inboard from the outermost plane of the vehicle.</p> <p>26. It must not increase the overall width of the vehicle.</p> <p>27. The device must not be used for the attachment of air or hydraulic brake pipes.</p> <p>28. Where the forward edge lies in open space then the following requirements must be met (see Note 10):</p> <ul style="list-style-type: none"> a. There must be a continuous vertical member extending over the whole height of the device. b. For N2 vehicles, the outer and forward faces must measure at least 50 mm rearward and be turned 100 mm inwards (see Note 11 & figure 2 A). c. For N3 vehicles, the outer and forward faces must measure at least 100 mm rearward and be turned 100 mm inwards (see Note 11 & figure 2 B).

Lateral Protection 42

Method of Inspection	Required Standard
<p>Note 5: Any adjacent parts may overlap providing that all overlapping edges face rearwards or downwards.</p> <p>Note 6: Dome shaped bolt heads and rivets, or other parts provided they are similarly rounded and smooth protruding to a maximum of 10mm in height are acceptable.</p> <p>Note 7: Where items protruding less than 5mm are added to the outer surface of Lateral Protection Devices, the edges only require blunting; corners will however require a radius of at least 2.5mm in two planes.</p> <p>Note 8: Combinations of surfaces and rails shall be considered as a continuous side guard as long as the gaps between them are no greater than 25mm.</p> <p>Note 9: On a motor vehicle where the 300 mm dimension referring to the forward edge of the sideguard falls within the cab, the guard must be constructed to meet the cab panels and if necessary be turned in through an angle not exceeding 45 degrees. A longitudinal gap of 100 mm is permissible between the forward edge and the cab panels.</p> <p>Note 10: "Open Space", is defined as a gap of more than 25mm.</p> <p>Note 11: The inward measurement is taken at 90 degrees to the longitudinal plane of the vehicle from the outer face of the guard; the actual face of the portion turned inwards may be between 90 and 45 degrees from the same plane towards the front of the vehicle.</p>	

Method of Inspection	Required Standard
<p>Note 12: This does not apply to Radar/Blind Spot Information System (BSIS) devices.</p> <ul style="list-style-type: none"> • Where horizontal rails are used to form part of the lateral protection device, Radar/BSIS devices must not be mounted onto or over the outer surface of these rails. • Where panels are fitted onto horizontal rails forming the lateral protection device, Radar/BSIS devices must not be affixed at the outer surface level with these rails within the area required to be protected. • Radar/BSIS devices must comply with: <ul style="list-style-type: none"> ○ Radius requirements (RS8). ○ Gap requirements (RS14), where fitment is incorporated into the side guard or body side. • Annex 1, Section 48a (Masses and Dimensions) must be considered when assessing the total protrusion of Radar/BSIS devices against the overall width measurement of the vehicle. <p>Examples of acceptable Radar/BSIS device fitment methods are shown in Figure 6.</p>	

Figure 1

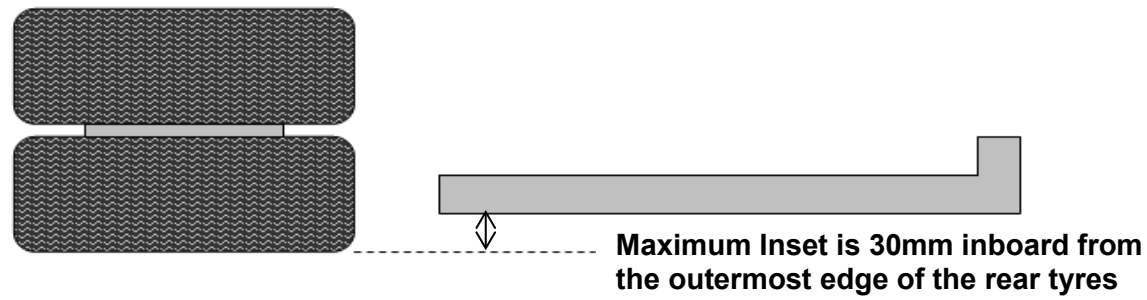
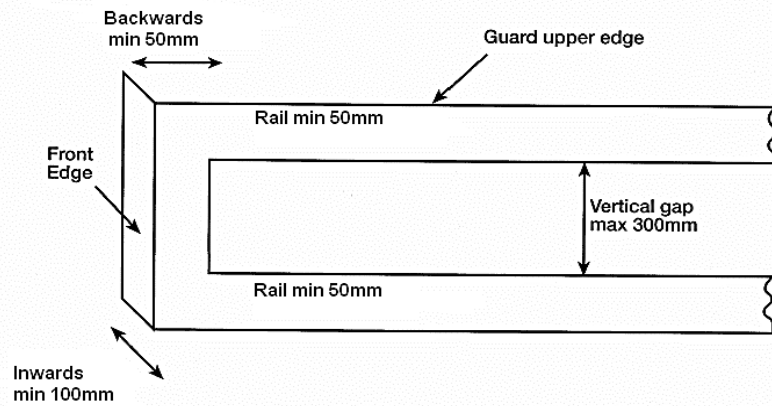

Figure 2

A



B

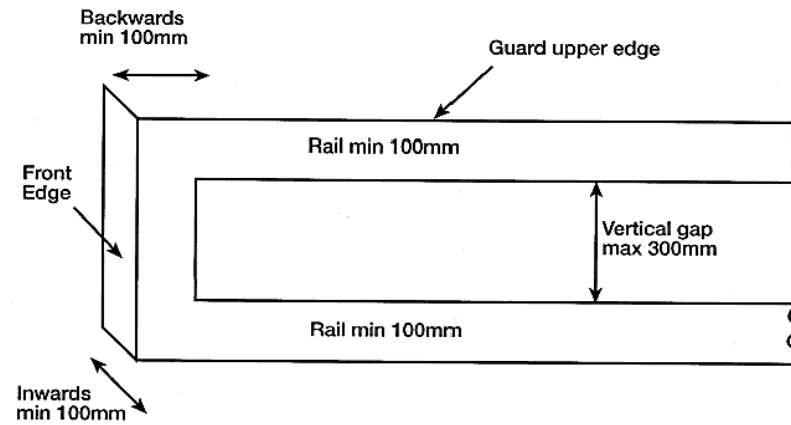
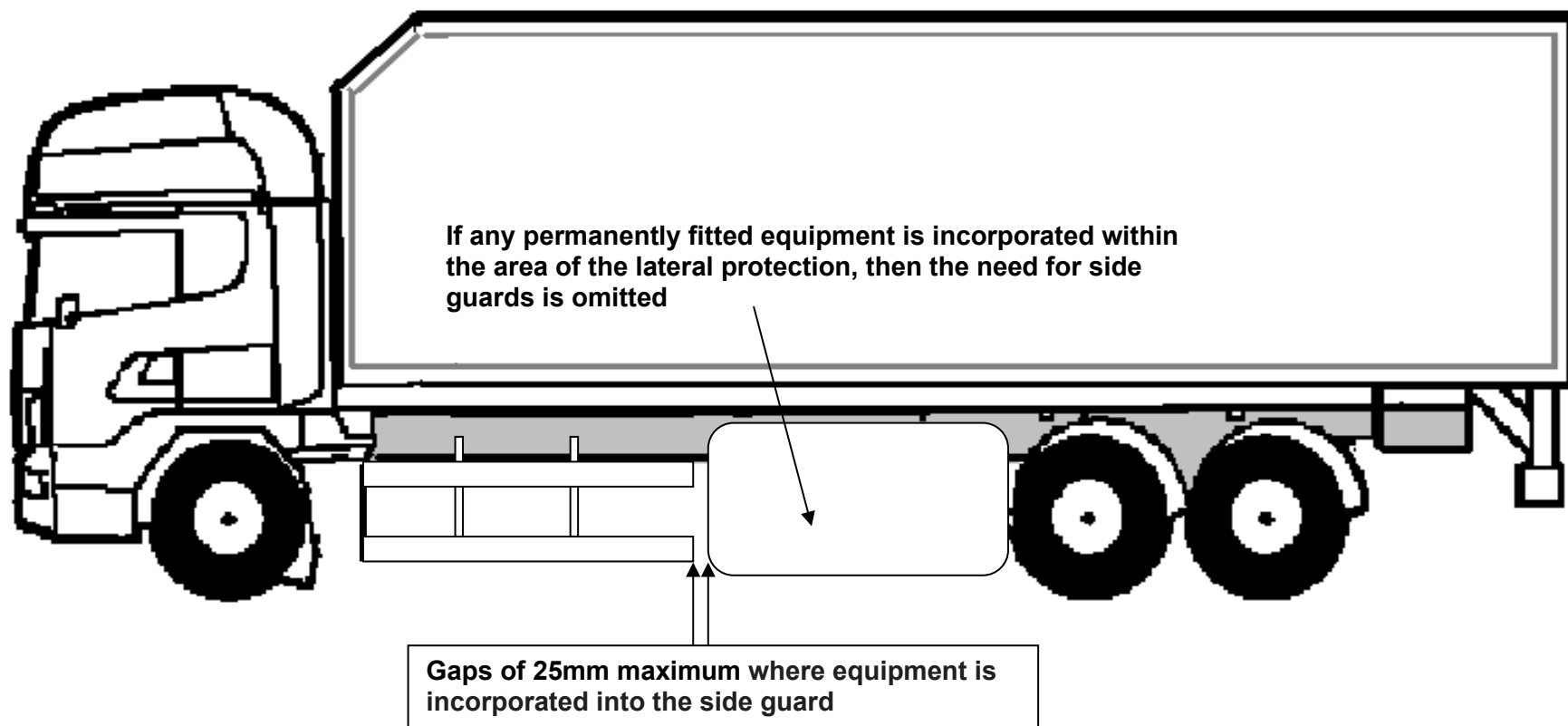

Figure 3



Lateral Protection 42

Figure 4

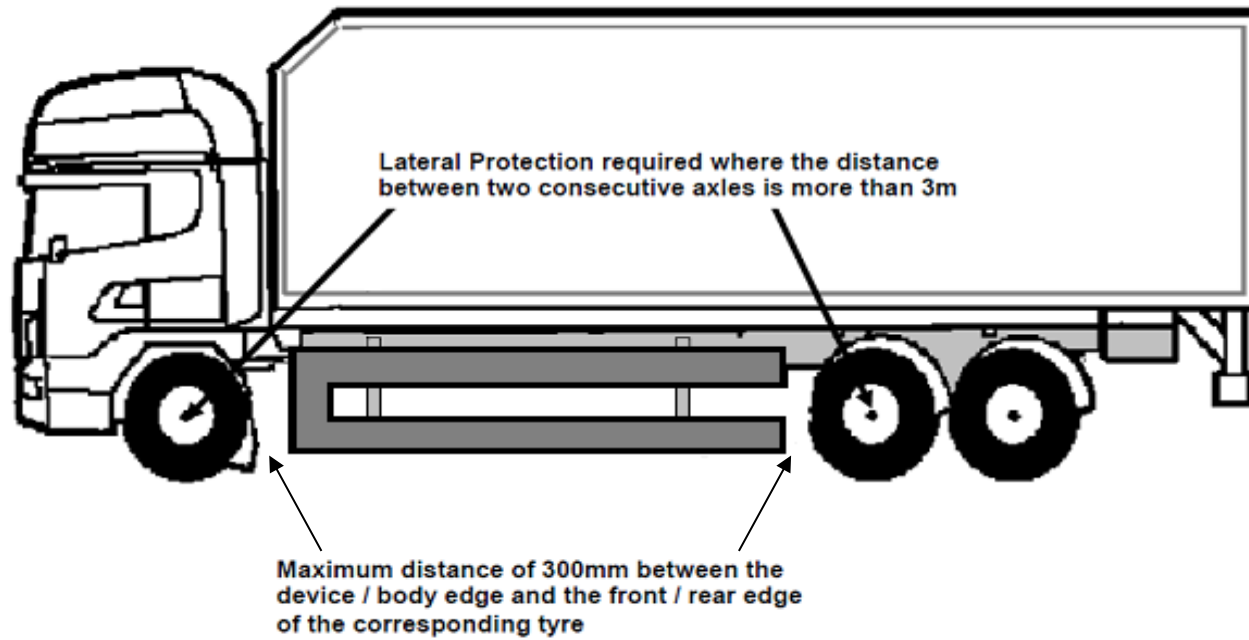

Figure 5

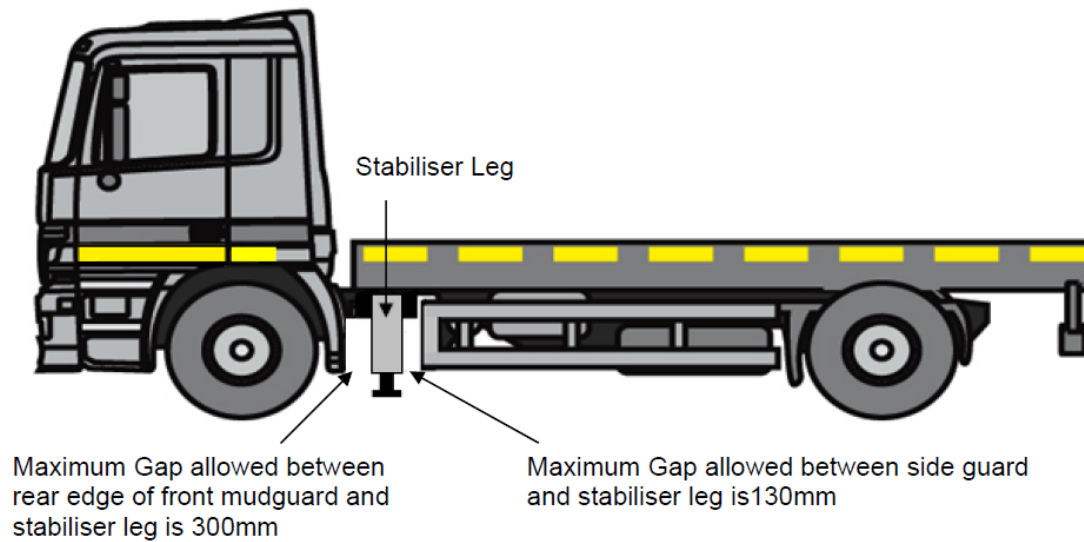

Figure 6

Examples of acceptable Radar/BSIS device fitment methods



The BSIS device is installed on a panel with open space behind it.



The BSIS device is positioned on a bracket secured by utilising the mounting section of the rail.



The BSIS device is positioned within the gap between the rails, ensuring continuity of the lateral protection device.

Record of Revision

Revision	Date	Description of Change
1	24/04/2009	
2	16/08/2010	Add A & B to figure 3 and RS 22, 23 and 28
3	31/01/2011	Add exemptions, add new diagram and standards for stabiliser legs
4	31/07/2011	New Note 1 added – renumbered other notes
5	30/04/2012	Add new exemptions and reorder Mol
6	29/10/2012	Amend paragraph following Note 1.
7	03/02/2014	Reformat Section, Revise description of car transporter, insert new note 1, revise RS9 & 17
8	29/10/2014	Add new exemptions and amend RS25
9	01/09/2015	New note 9 (additions to outside face of lateral protection)
10	10/04/2018	Add figure 5 to note 7, Add Note 10 & 11
11	28/11/2025	Paragraph added to Mol relating to exempted vehicle requirements (TSE N2N3 042 008). Note 3 format revised. Reference to Note 6 corrected & added reference to new Note 12 from RS9. Added reference to new Note 12 from RS13. Added reference to new Note 12 from RS17. (TSE IVA N2N3 042 006). Heading for RS13-18 revised. Figure 6 added.

This page intentionally left blank

43 Spray Suppression

Application: All Vehicles

Method of Inspection		Required Standard
All road wheels must be fitted with Spray Suppression devices. Vehicle Exemptions:		<p>Component Check</p> <ol style="list-style-type: none"> Every road wheel must be fitted with a Spray Suppression system. All Spray Suppression material must be of an approved type (see Notes 1 & 2). All components must be secured so that they perform their function. <p>Installation Check</p> <p>Mudguards (fitted in combination with energy absorption materials).</p> <ol style="list-style-type: none"> must fully cover the zone immediately above, ahead and behind any part of the tyre or tyres in the case of non-steered wheels must have the lower front edge no more than 45 degrees above the horizontal line of the axle (A on figure 1) in the case of steered wheels must have the lower front edge no more than 45 degrees above the horizontal line of the axle (A on figure 1) must have the lower-rear edge no more than 100mm above the horizontal line of the axle (C on figure 1). must have Spray Suppression material fitted to the front face of the rear of the guard facing the tyre tread, complying with the dimensional requirements of Figure 1 & 3.
Vehicle Type	Exemption Provided	
All vehicles up to 7500kg	Exemption from spray suppression but will require mud guards.	
<ul style="list-style-type: none"> Multi wheel drive motor vehicles (capable of driving at least one front axle and one rear axle) High ground clearance motor vehicles (>400mm) Off Road Vehicles 	Exemption from spray suppression but will require mud guards.	
Motor vehicles with tipper bodies – side tipping or rear tipping	Tipplers are exempt from spray suppression but will require mud guards.	
Refuse vehicles including refuse collection vehicles, road sweepers, skip loaders and gulley emptiers	Exemption from spray suppression but will require mud guards.	
Concrete /Volumetric Mixers	Exemption from spray suppression but will require mud guards.	
Mudguards must comply with RS 4, 5, 6 & 7		

Spray Suppression 43

Method of Inspection	Required Standard
<p>STGO Exempt Vehicles: Abnormal Indivisible Load (AIL) vehicles > 2.55m (2.75m for locomotive wide) and/or > 12m long which are either Cat 2 <80T and Cat 3 <150T.</p> <p>Definitions</p> <p>Mudguard Is a device to prevent as far as practical mud or water being thrown from a tyre. They may be formed using parts of the body or they may be an entirely separate unit.</p> <p>Outer Valances Are usually strips of material that are fitted longitudinally across a wheel space attached at one end to a rain flap to form an outer wheel arch lip, a vertical downward face that closes off what would be an open area.</p> <p>Rain flaps Can be a flexible extension to a mudguard or it may form the rear most vertical face of a mudguard in conjunction with the body, in this latter case it must be treated as a mudguard and be securely fixed to prevent excessive movement.</p> <p>Lifting axles Where a vehicle is fitted with one or more lifting axles, the spray-suppression system must cover all the wheels when the axle is lowered and the remaining wheels which are in contact with the ground when the axle is raised.</p> <p>Self-tracking axles Where a vehicle is fitted with a self-tracking axle, the spray-suppression system must satisfy the conditions applicable to non-steered wheels if mounted on the pivoting part. If not mounted on that</p>	<p>9. that consist of several components must have no gaps between or within individual parts when assembled that will permit the exit of spray when the vehicle is in motion.</p> <p>Additional standard where Separate Mudguards are fitted (in combination with air/water separation to multiple axle configurations).</p> <p>10. Where the distance between the tyres on adjacent axles does not exceed 300 mm the mudguards must also conform to the model shown in Figure 7.</p> <p>Alternative Standards from standards 4-10 where the body forms the mudguards (and energy absorption systems are fitted).</p> <p>11. must cover the zone above the tyre or tyres from the front edge of the tyre to the rain flap located behind the wheel (see Figure 5).</p> <p>12. must have their inner faces made from or be fitted with a spray suppression material.</p> <p>Outer Valances (with energy absorption Spray Suppression systems installed).</p> <p>13. fitted to steered and self-steered wheels must have its vertical face within 100mm of the tyre wall (D on figure 2) (see Note 3).</p> <p>14. fitted to non -steered wheels must have its vertical face within 75 mm of the tyre wall (D on Figure 2) (see Note 3).</p> <p>15. must have a depth of at least 45mm, at all points behind a vertical line passing through the centre of the wheel see Figure 2.</p> <p>16. fitted to steered wheels must have the lower edge within 1.8 x tyre radius at points A, B, & C as shown in Figure 4</p>

Method of Inspection	Required Standard
<p>part, it must satisfy the conditions that are applicable to steered wheels.</p> <p>Note 1: All spray suppression materials must be either e marked or be accompanied by an e marked sample of the material to permit the examiner to make a comparison.</p> <p>Note 2: 'Spray-suppression device' means part of the spray-suppression system, which may comprise:</p> <p>Air/water separator: This is a component forming part of the valance and/or of the rain flap through which air can pass whilst reducing pulverized water emissions.</p> <p>or</p> <p>Energy absorber: This is a component forming part of the mudguard and/or valance and/or rain flap which absorbs the energy of water spray, thus reducing pulverized water spray.</p> <p>Note 3: Where rope hooks are fitted the outer valance may meet the requirements of figure 6 as an alternative.</p> <p>Note 4: The maximum height of the bottom edge of the rain flap in relation to the ground, may be raised to 300 mm if the manufacturer deems it technically appropriate with regard to the suspension characteristics e.g., 'road friendly' suspension.</p>	<p>17. fitted to non - steered wheels must have the lower edge within 1.5 x tyre radius at points A,B and C as in Figure 4</p> <p>18. must have no openings in them or between them and other parts of the mudguard enabling spray to emerge.</p> <p>Alternative standards (to 13 -18) for Outer Valances (where the body forms the mudguard over non steered or self-steering wheels and a energy absorption spray suppression system is installed).</p> <p>19. must be located above each wheel of multiple axles where a rain flap is fitted between each wheel (see Figure 5).</p> <p>20. must have the entire inner surface fitted with an energy-absorption spray-suppression material</p> <p>21. must be a minimum of 100mm high</p> <p>22. must have no openings in them or between the outer valance and the inner part of the mud guard enabling spray to emerge</p> <p>23. must be continuous where rain flaps are not fitted behind each wheel, they must extend between the outer edge of the rain flap and a vertical plane passing through the front edge of the tyre. See figure 5.</p> <p>Outer Valances (with air/water separation Spray Suppression systems installed).</p> <p>24. must have air/water separator spray-suppression devices fitted to the lower edges.</p> <p>25. must have a depth of at least 45mm, at all points behind a vertical line passing through the centre of the wheel</p> <p>26. fitted to steered wheels must have its lowest edge within 1.05 x tyre radius see figure 7</p>

Spray Suppression 43

Method of Inspection	Required Standard
	<p>27. fitted to non-steered wheels must have its lowest edge within 1 x tyre radius see figure 7</p> <p>28. must have no openings in them or between them and the mudguard enabling spray to emerge</p> <p>29. In the case of non-steered wheels must have the lower front edge no more than 20 degrees above the horizontal line of the axle (A on figure 1)</p> <p>30. In the case of steered wheels must have the lower front edge no more than 30 degrees above the horizontal line of the axle (A on figure 1)</p> <p>Rain Flaps: (where energy absorption Spray Suppression systems are installed)</p> <p>31. must be at least equal to the full width of the tyre/s.</p> <p>32. must be vertical.</p> <p>33. must have the lower edge no more than 200 mm above the ground. (see Note 4).</p> <p>34. must be no more than 300 mm from a vertical plane passing through the rearmost edge of the tyre.</p> <p>35. must have no openings between the rain flap and the lower edge of the wheel guard enabling spray to emerge.</p> <p>36. must have the whole face made of spray suppression material.</p> <p>37. must be fitted to the rearmost axle of multiple axles where distance between the tyres on adjacent axles is less than 250 mm.</p>

Spray Suppression 43

Method of Inspection	Required Standard
	<p>38. must be fitted behind each wheel of multiple axles when the distance between the tyres on adjacent axles is 250 mm or greater.</p> <p>Rain Flaps: (where the body forms the mudguard and energy absorption Spray Suppression systems are installed)</p> <p>39. must extend to the lower part of the mud guard and comply with Standards 29 to 36.</p> <p>Rain Flaps (where air/water Separation Systems are installed)</p> <p>40. must be at least equal to the full width of the tyre/s.</p> <p>41. must be vertical.</p> <p>42. must have no openings between the rain flap and the lower edge of the wheel guard enabling spray to emerge.</p> <p>43. must be fitted to the rearmost axle of multiple axles where distance between the tyres on adjacent axles is less than 250 mm.</p> <p>44. must be fitted behind each wheel of multiple axles when the distance between the tyres on adjacent axles is 250 mm or greater.</p> <p>45. must not be more than 200 mm from the rearmost edge of the tyre, measured horizontally.</p> <p>46. must be at least 100 mm deep (see Figure 7).</p>

Spray Suppression 43

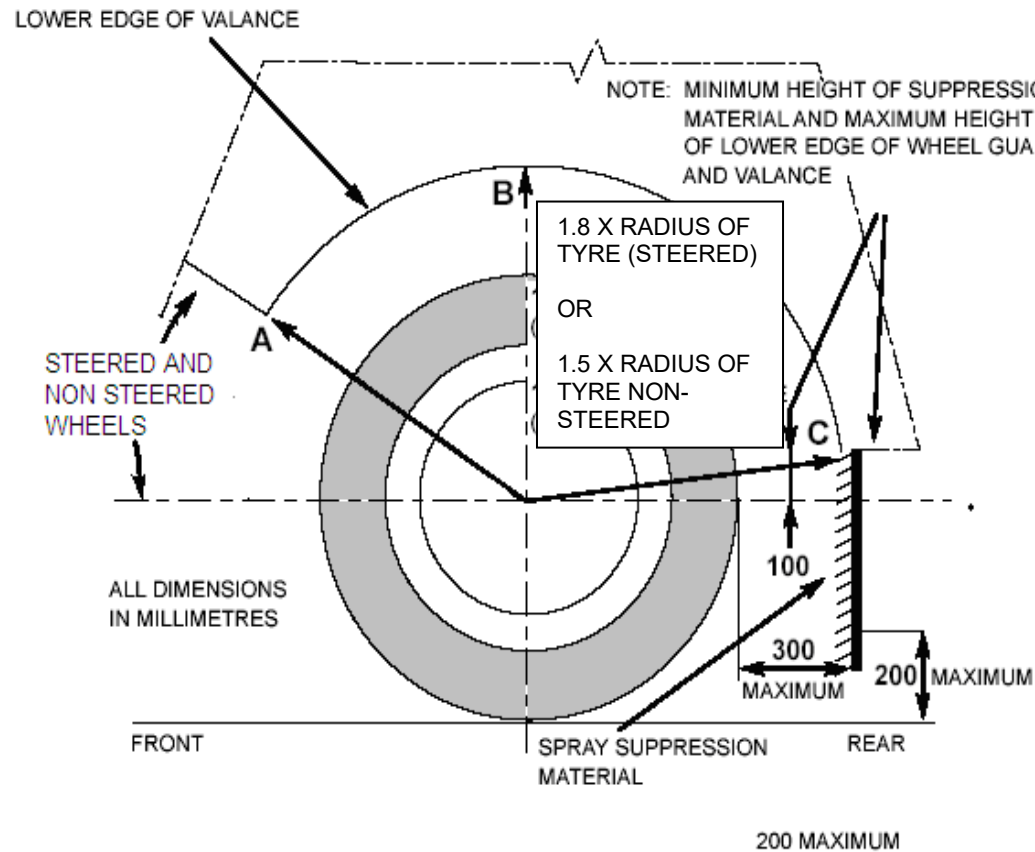

Figure 1

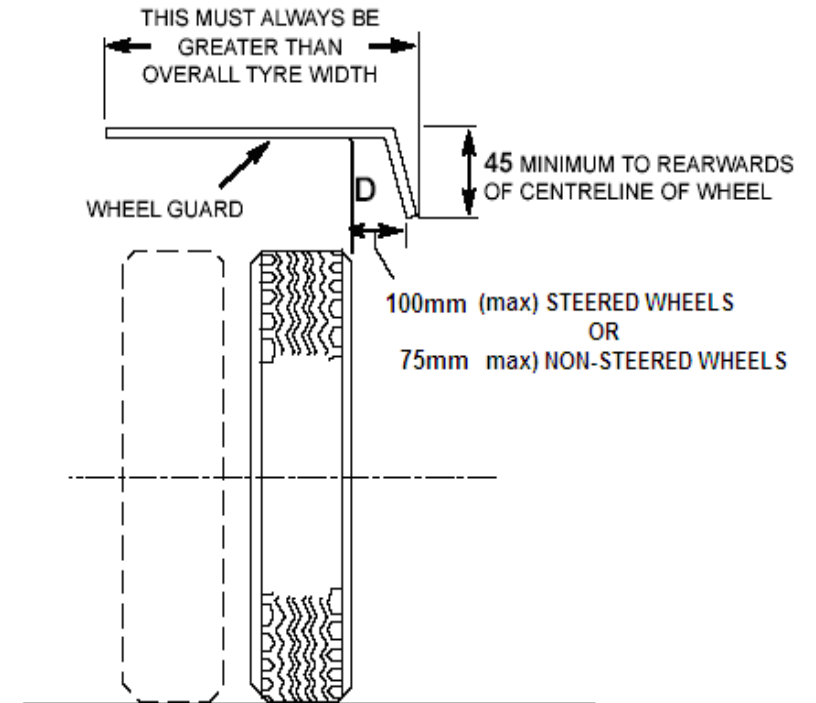
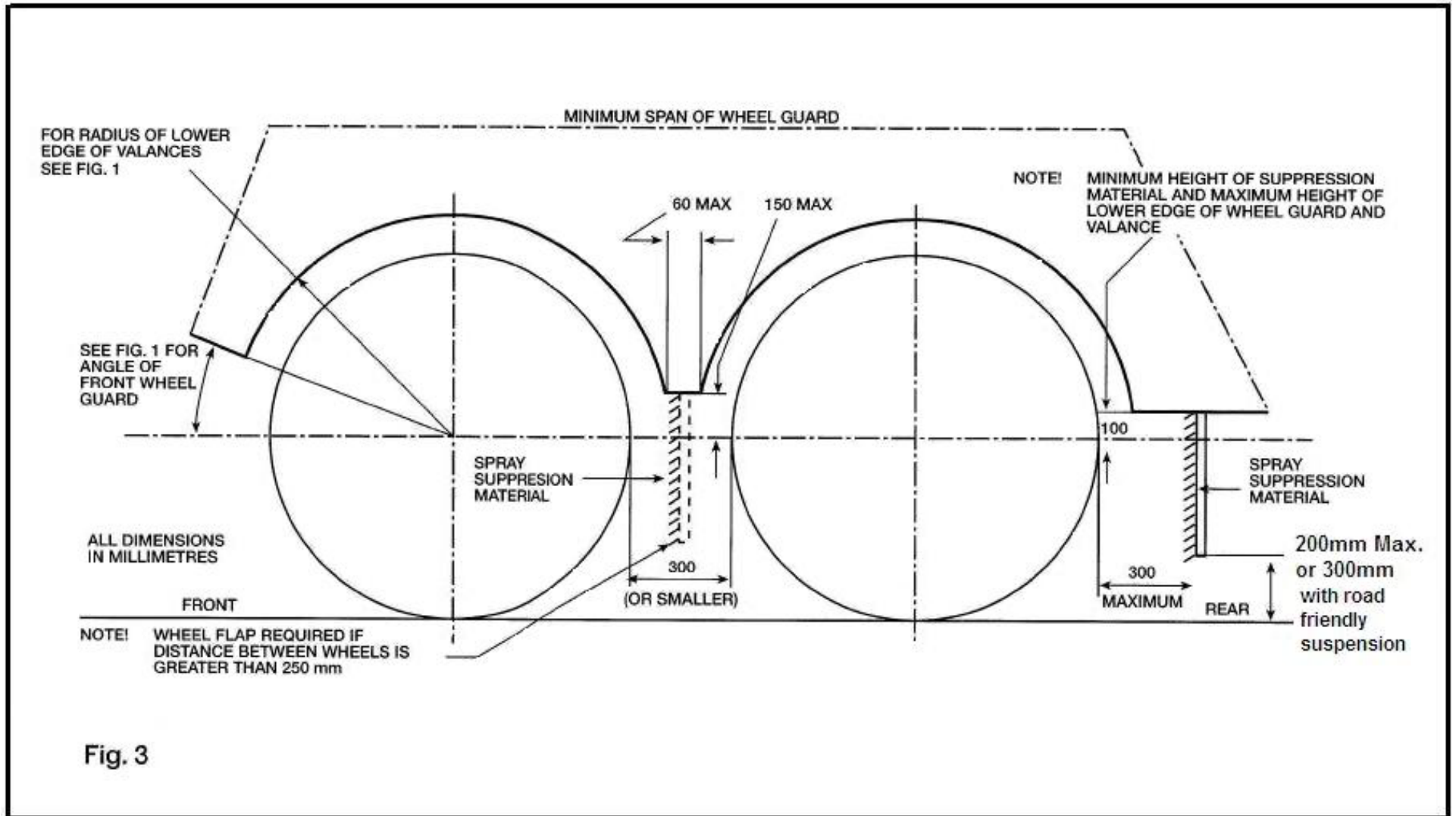

Figure 2



Spray Suppression 43

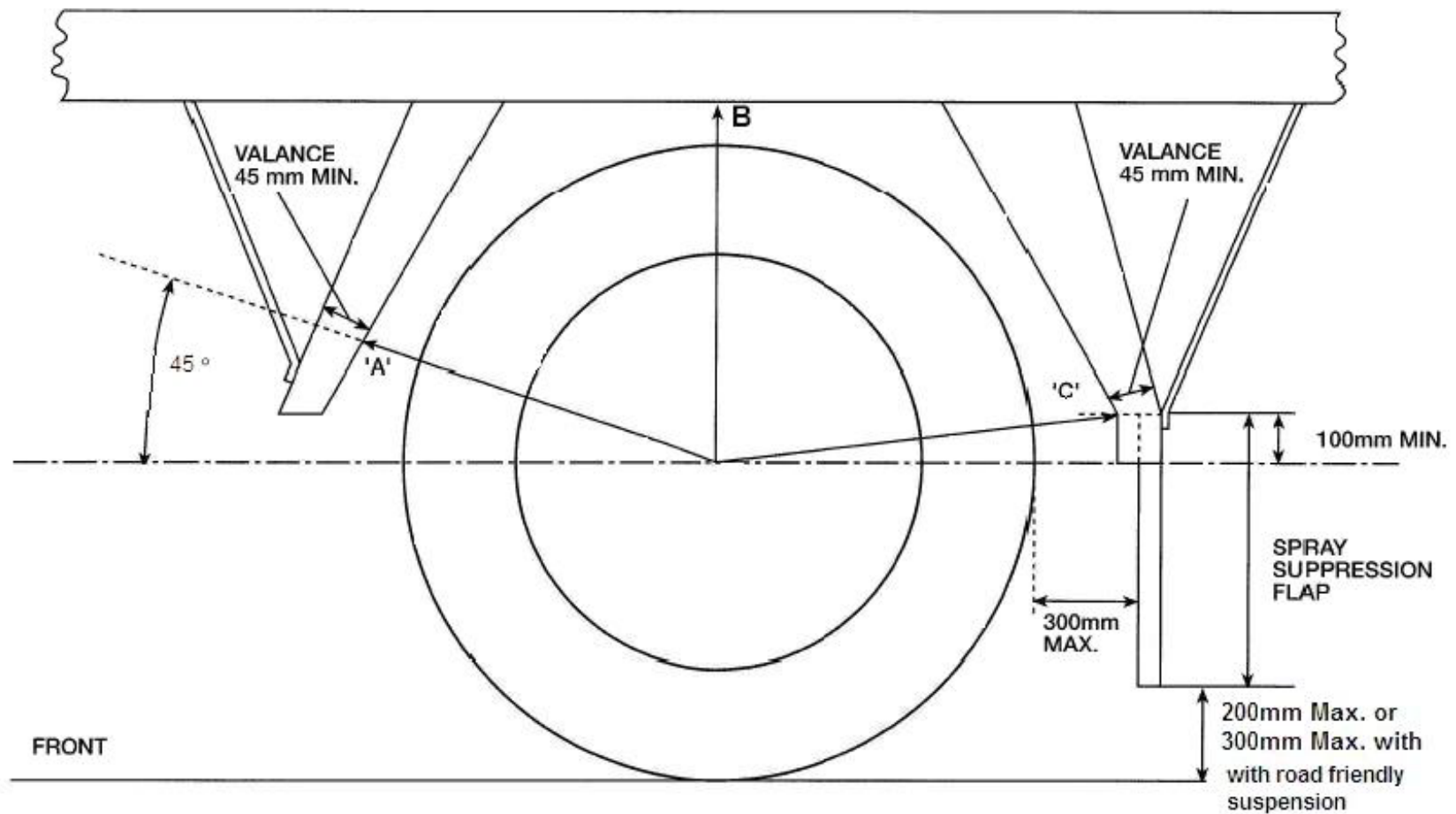

Fig. 4

The lower edge of the outer valance shall not exceed 1.8 X tyre radius on steerable wheels, or 1.5 X tyre radius on non-steerable wheels at points A, B, & C

Spray Suppression 43

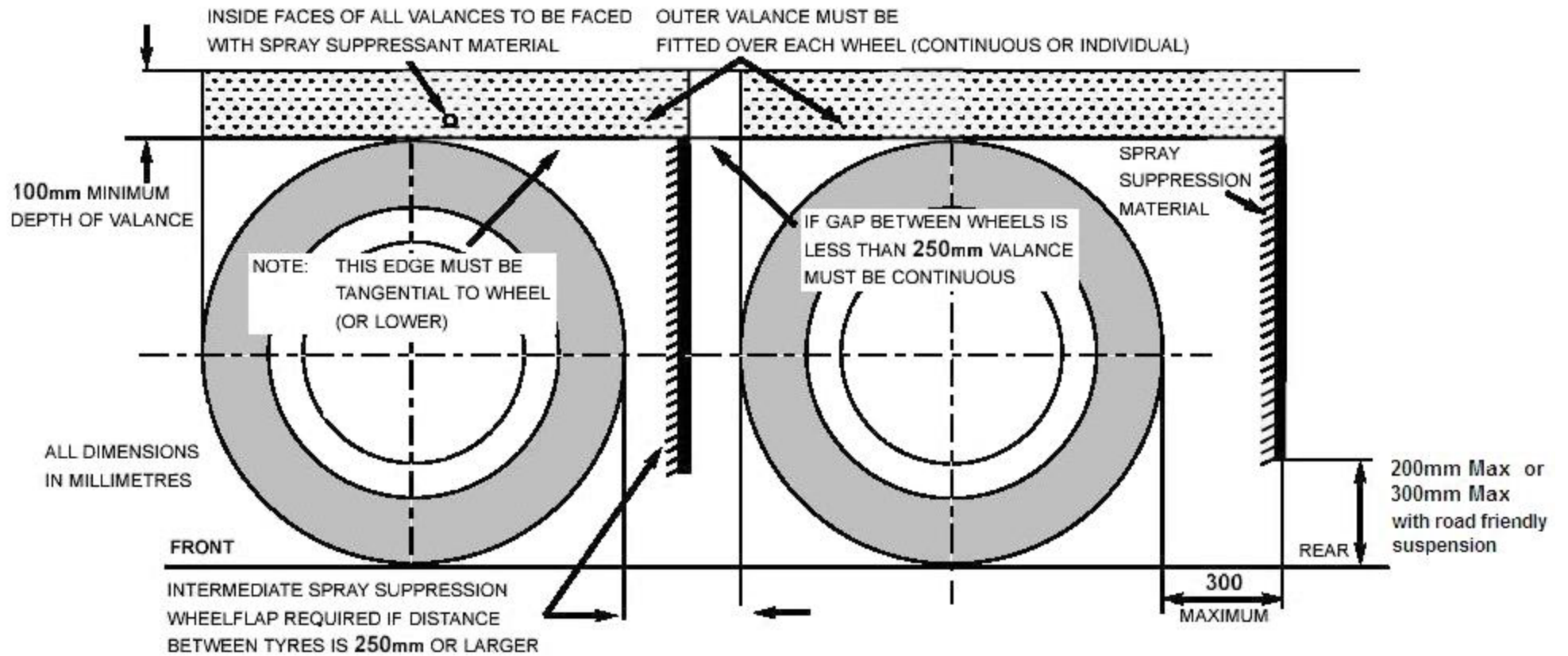
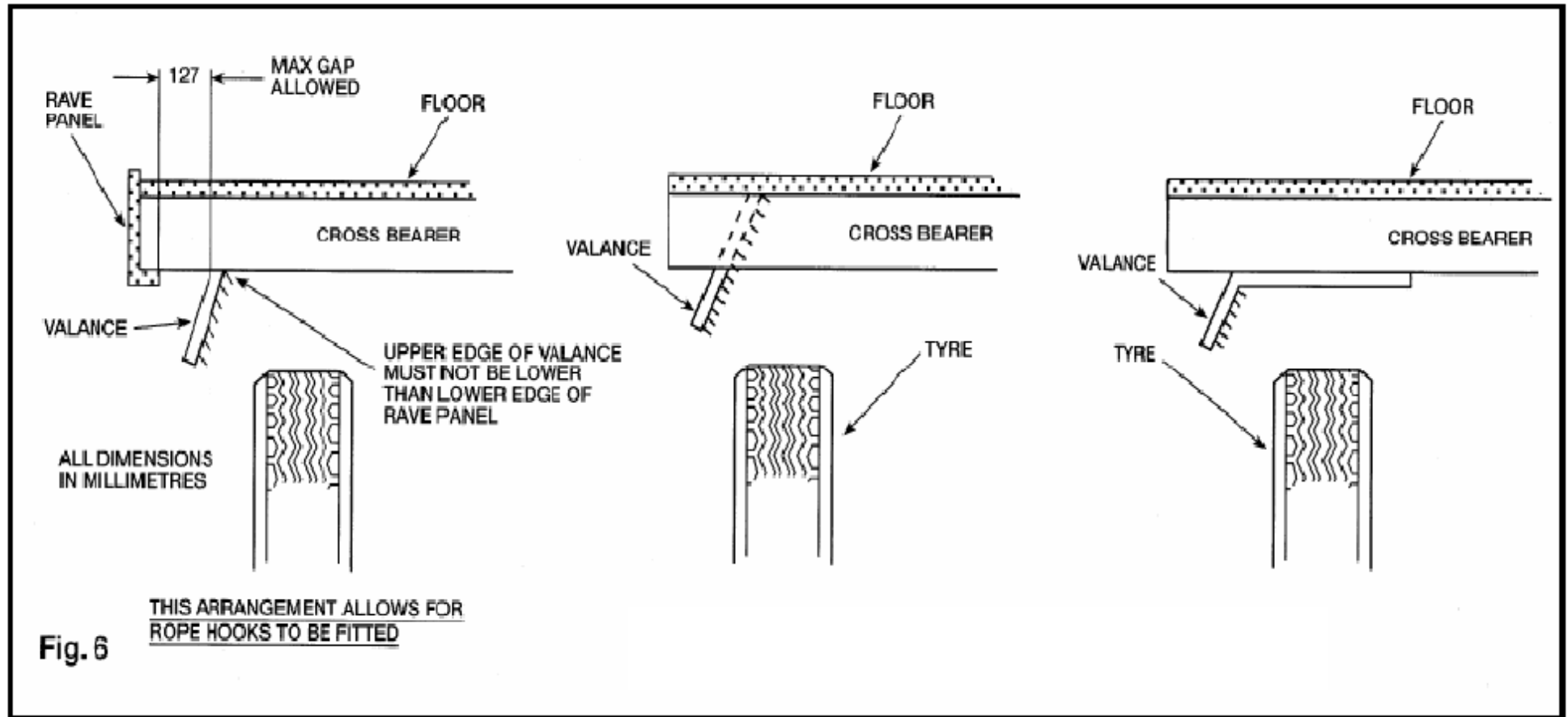

Figure 5

Spray Suppression 43



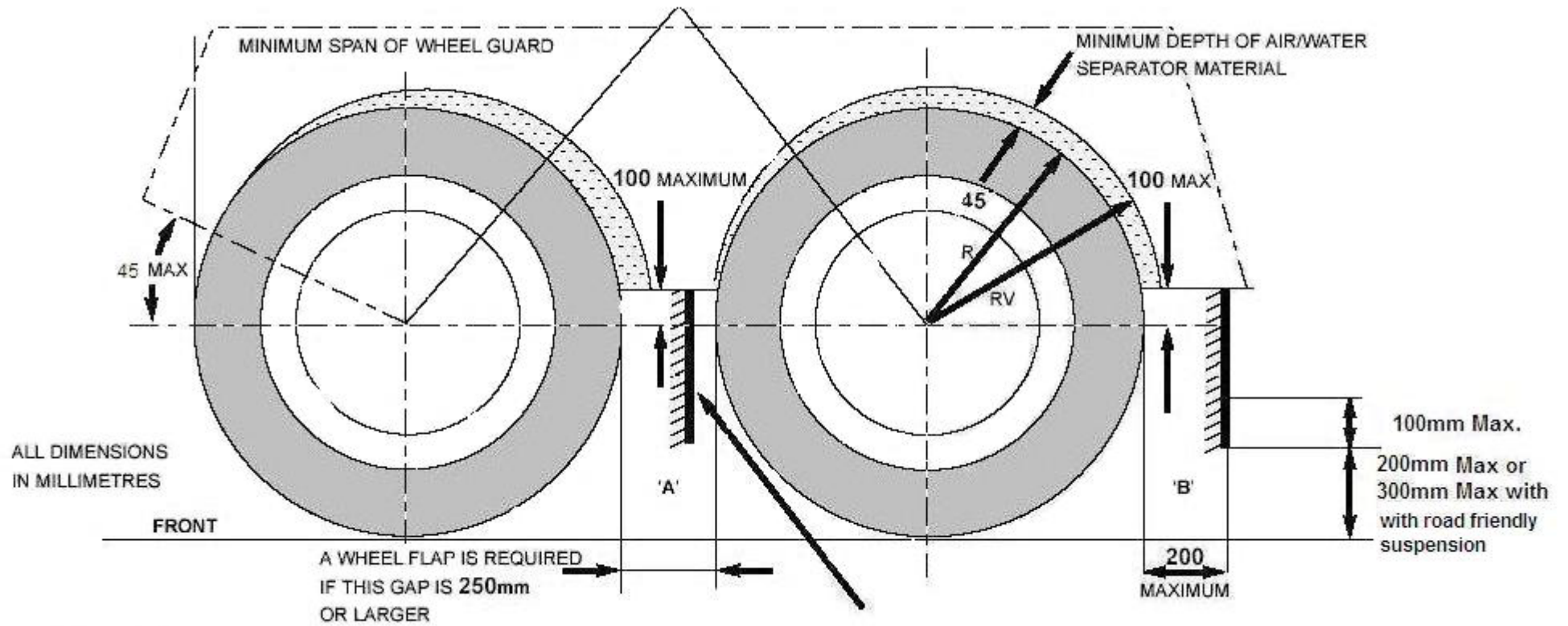

Figure 7

where:

R = the radius of tyre fitted to the vehicle.

RV = the radial distance from the lowest edge of the outer Valve to the centre of the wheel.

$RV \leq 1.05$ on steered wheels

$RV \leq 1.00$ on non-steered wheels

Record of Revision

Revision	Date	Description of Change
1	24/04/2009	
2	31/01/2011	Add exemptions
3	31/07/2011	Add link from RS44 to fig 7
4	03/02/2014	Amend Application header and Exemption table, insert new note 4, update angle of mudguard front edge in RS5 & 6 and in Figures 1, 4 & 7, and revise Figs 3, 4, 5 & 7
5	29/10/2014	STGO exemption added, note 4 corrected, diagrams corrected
6	01/09/2015	Amendments to exemptions table
7	10/04/2018	Amend RS 29 & 30 & Figure 1, Amend RS 16 & 17 + Fig 1 & Fig 4
8	20/10/2023	Skip loaders added to list of exempt refuse vehicles (TSE IVA N2N3 043 003)

45 Safety Glass

Application: All Vehicles (except Armoured vehicles)

Method of Inspection	Required Standard
<p>Ensure that all windscreens, windows, internal glazed panels, and side screens are securely attached to the vehicle and are constructed from approved materials.</p> <p>Clear panels, not made of glass, fitted to the vehicle that do not impinge on the forward, rearward or sideward view of the driver are considered to be body panels and are not subject to the requirements of this section.</p> <p>The inspection of internally glazed panels applies to a partition or screen divider used for the separation of driver to passenger area or for passenger protection. It does not apply to such items like; break glass hammer panels, fire extinguisher panels or L.E.D information screens etc. This is not an exhaustive list but is provided as guidance.</p> <p>Note 1: “Safety Glazing” made from glass or plastic must be so constructed or treated that if fractured it does not fly into fragments likely to cause severe cuts. Each piece of glazing must display the relevant permanent marking applied by the manufacturer.</p> <p>Example Marking  43R</p> <p>Note 2: Exterior glazing must meet the requirements of Table 1 when the vehicle is in motion even when covered by shutters.</p> <p>Note 3: This only applies to those windows or parts of window affording the driver a view of the road.</p>	<ol style="list-style-type: none"> 1. Windscreens, windows, internal glazed panels, and side-screens where fitted must be securely attached to the vehicle. 2. Windscreens, windows, internal glazed panels, and side-screens where fitted must be suitable for use (see Table 1). 3. Windscreens and windows wholly or partly on either side of the driver’s seat must be “Safety Glazing” made from glass and display the relevant markings (see Note 1 and Table 1). 4. All other windows (including sunroofs internal glazed panels and removable glass panels) and side-screens must be “Safety Glazing” (which may be made from glass, or from plastic) and display the relevant markings (see Notes 1 & 2 and Table 1). 5. Windscreens and windows wholly or partly on either side of the driver’s seat must allow a light transmission of at least 70% (see Note 3).

Table 1

Type of window	Relevant Markings (Mandatory) In addition to "e" approval	Markings (Not Allowed)
Windscreen	II -for ordinary laminated glass III -for treated laminated glass IV -for glass-plastics glazing.	V - safety glazing having a regular light transmittance less than 70 per cent. VI - double-glazed unit VII - uniformly-toughened glass which can only be used as windscreens for slow-moving vehicles which, by construction, cannot exceed 40 km/h. VIII -In the case of rigid plastic glazing.
Windows wholly or partly on either side of the driver's seat	VIII -In the case of rigid plastic glazing. In addition, the appropriate application will be signified by: /B for side, rear and roof glazing	V -in the case of safety glazing having a regular light transmittance less than 70 per cent. VII - uniformly-toughened glass which can only be used as windscreens for slow-moving vehicles which, by construction, cannot exceed 40 km/h. VIII -In the case of rigid plastic glazing. In addition, the appropriate application will be signified by: /A for forward facing panels, /C in locations where there is little or no chance of head impact.
Other windows and other glazed panels	None	VII - uniformly-toughened glass which can only be used as windscreens for slow-moving vehicles which, by construction, cannot exceed 40 km/h.

These symbols may be marked down in a different format i.e., **II - IV**

Laminated glass

Means a glass pane consisting of two or more layers of glass held together by one or more interlayers of plastics material; it may be:

- **"ordinary"**, when none of the layers of glass of which it is composed has been treated; **or**
- **"treated"**, when at least one of the layers of glass of which it is composed has been specially treated to increase its mechanical strength and to condition its fragmentation after shattering.

Glass-plastics glazing

Means a pane of laminated glass having one layer of glass and one or more layers of plastics material, at least one of which acts as interlayer. The plastics layer(s) shall be on the inner face when the glazing is fitted on the vehicle.

Rigid plastic glazing

Means a plastic glazing material which does not deflect vertically more than 50 mm in the flexibility test as shown in **UNECE Regulation 43**

Record of Revision

Revision	Date	Description of Change
1	24/04/2009	
2	16/08/2010	Add statement to MOI
3	30/04/2012	Add exemption for Armoured Vehicles to Application Box, and remove from RS 5
4	03/02/2014	Insert new Note 2
5	01/09/2015	Amendment to note 1
6	10/04/2018	Amend table 1 note
7	01/09/2020	Expand MOI

This page intentionally left blank

46 Tyres

Application: All Vehicles

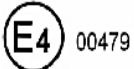
Method of Inspection	Required Standard
<p>Check each tyre for correct fitment, structure and that it has the correct markings to confirm compliance with the required standards. (Where it is not possible to check markings, a declaration will be required from the applicant).</p> <p>In the case of an Armoured vehicle, or Mobile crane, exemption from one or more of the provisions is permitted where it can be demonstrated to the satisfaction of the Approval Authority that the special purpose of the vehicle makes it impossible to fully comply.</p> <p>In the case of a Mobile crane the provision in the above paragraph applies on condition that the requirements in ISO 10571 – 1995 (E) or ETRTO Standards Manual 1998 are fulfilled. (Satisfactory documentary evidence would be required).</p> <p>Annex 1</p> <div style="display: flex; justify-content: space-around;"> <div style="text-align: center;"> <p>EC Type Approval Mark</p> <p>Box should be a minimum of 12mm x 8mm</p>  <p>Letters and numbers, minimum of 4mm high</p> </div> <div style="text-align: center;"> <p>UNECE Type Approval Mark</p> <p>Circle with a minimum diameter of 12mm</p>  <p>Number 4mm high and serial number alongside</p> </div> </div> <p>Re-treaded tyres must be approved and suitably e-marked according to UN Regulation No. 109, incorporating the manufacturers approval number as per the example below:</p>	<ol style="list-style-type: none"> 1. Each tyre fitted to the vehicle, including any spare or temporary use spare, must have the correct approval marks (Annex 1). 2. The tyre must also be marked with the following information: Manufacturer's name or trademark, tyre size designation, category of use (as appropriate), speed category, load capacity index and tyre cross section (see Note 1). 3. Each of the tyres fitted to a vehicle, must have the same structure (see Note 2). 4. Each of the tyres fitted to any one axle must be of the same type (see Note 3). 5. Each tyre must have the correct load indices, speed ratings and use markings, taking into account the vehicle to which it is fitted, and the type of use i.e., load and speeds the vehicle will be subject to (see Notes 1, 2, 3, 4, 5 & 6 and tables 1, 2, 3 & 4). 6. Each wheel and tyre must have sufficient room to revolve so as to ensure that it is unlikely to foul on any part, taking into consideration the suspension and steering constraints provided by the manufacturer. 7. Tyres must be fitted in accordance with the manufacturer's instructions as indicated on the side wall of the tyre (see Note 7). 8. The grooves of the tread pattern must be at least 1mm in depth through a continuous band comprising of at least $\frac{3}{4}$ of the original breadth of the tread pattern (excluding wear indicators).

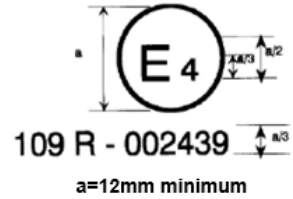
Method of Inspection	Required Standard
<p>UNECE Type Approval mark</p>  <p>Note 1: Tyres with no category of use designation (special, snow tyre etc), will be deemed to be Normal Use Tyres.</p> <p>Note 2: Structure means the technical characteristics of the tyre's carcass, such as diagonal or bias ply, bias belted, Radial, reinforced.</p> <p>Note 3: <i>Type of tyre</i> means tyres which do not differ in such essential respects as manufacturer's name or trademark, tyre size designation, category of use (special, snow tyre, etc.), speed category, load capacity index, and tyre cross-section. NB: When dealing with an age-related IVA and imported used vehicles, 'manufacturer's name or trademark' does not apply in the above definition.</p> <p>Note 4: Operators may display a 50mph sticker on the rear of their vehicle, they must have documentary evidence to claim the vehicle is one with a restricted speed.</p> <p>Note 5: Vehicles running under STGO can be fitted with tyres showing a lower maximum load as running speeds will be reduced, see Table 4.</p> <p>Note 6: As an alternative to rejecting a vehicle for a tyre of inadequate load capacity the applicant may choose to reduce the GB weights to that of the tyre capacity. (The examiner must also ensure that the DVSA technical record is correct).</p>	

Method of Inspection	Required Standard
<p>Note 7: Tyres may be branded for a recommended use while still being suitable for other applications. If any doubt exists, satisfactory documentary evidence or a declaration from the tyre manufacturer may be requested.</p>	

Table 1

The Minimum required speed ratings

Class of Vehicle	Permitted Speed MPH	Minimum Speed Symbol Required
Rigid goods vehicles with a maximum laden weight not exceeding 7.5 tonnes	70	L
Rigid goods vehicles with a maximum laden weight exceeding 7.5 tonnes	60	J
Articulated vehicles	60	J
Goods vehicles operating under 2J or 2M tyre use conditions	40	D
Restricted speed vehicles operating under 2R tyre use conditions	50	F

Table 2

Alternative Speed Ratings

Certain vehicles can be fitted with tyres showing a lower speed rating than those shown above but the maximum axle loads will be reduced as shown below.

Class of Vehicle	Normal Speed Rating	Alternative Speed Rating	Reduction in Axle Load
Motor vehicles not exceeding 7500kg plated weight	L	J	7 %
		K	3 %

Table 3

LOAD INDEX	SINGLE Kg	DUAL Kg	LOAD INDEX	SINGLE Kg	DUAL Kg	LOAD INDEX	SINGLE Kg	DUAL Kg	LOAD INDEX	SINGLE Kg	DUAL Kg
70	670	1340	100	1600	3200	130	3800	7600	160	9000	18000
71	690	1380	101	1650	3300	131	3900	7800	161	9250	18500
72	710	1420	102	1700	3400	132	4000	8000	162	9500	19000
73	730	1460	103	1750	3500	133	4120	8240	163	9750	19500
74	750	1500	104	1800	3600	134	4240	8480	164	10000	20000
75	774	1548	105	1850	3700	135	4360	8720	165	10300	20600
76	800	1600	106	1900	3800	136	4480	8960	166	10600	21200
77	824	1648	107	1950	3900	137	4600	9200	167	10900	21800
78	850	1700	108	2000	4000	138	4720	9440	168	11200	22400
79	874	1748	109	2060	4120	139	4860	9720	169	11600	23200
80	900	1800	110	2120	4240	140	5000	10000	170	12000	24000
81	924	1848	111	2180	4360	141	5150	10300	171	12300	24600
82	950	1900	112	2240	4480	142	5300	10600	172	12600	25200
83	974	1948	113	2300	4600	143	5450	10900	173	13000	26000
84	1000	2000	114	2360	4720	144	5600	11200	174	13400	26800
85	1030	2060	115	2430	4860	145	5800	11600	175	13800	27600
86	1060	2120	116	2500	5000	146	6000	12000	176	14200	28400
87	1090	2180	117	2570	5140	147	6150	12300	177	14600	29200
88	1120	2240	118	2640	5280	148	6300	12600	178	15000	30000
89	1160	2320	119	2720	5440	149	6500	13000	179	15500	31000
90	1200	2400	120	2800	5600	150	6700	13400			
91	1230	2460	121	2900	5800	151	6900	13800			
92	1260	2520	122	3000	6000	152	7100	14200			
93	1300	2600	123	3100	6200	153	7300	14600			
94	1340	2680	124	3200	6400	154	7500	15000			
95	1380	2760	125	3300	6600	155	7750	15500			
96	1420	2840	126	3400	6800	156	8000	16000			
97	1460	2920	127	3500	7000	157	8250	16500			
98	1500	3000	128	3600	7200	158	8500	17000			
99	1550	3100	129	3700	7400	159	8750	17500			

Table 4 (for variation of load capacity for STGO)

Speed (km/h)	Speed (mph)	Variation of load capacity (%)				
		All load indices			Load indices ⁽¹⁾ ≥ 122	Load indices ⁽¹⁾ ≤ 121
		Speed category symbol			Speed category symbol	Speed category symbol
		F	G	J, K	L, M	L, M, N, P
0	0	+ 150	+ 150	+ 150	+ 150	+ 110
5	3	+ 110	+ 110	+ 110	+ 110	+ 90
10	6	+ 80	+ 80	+ 80	+ 80	+ 75
15	9	+ 65	+ 65	+ 65	+ 65	+ 60
20	12.5	+ 50	+ 50	+ 50	+ 50	+ 50
25	16	+ 35	+ 35	+ 35	+ 35	+ 42
30	19	+ 25	+ 25	+ 25	+ 25	+ 35
35	22	+ 19	+ 19	+ 19	+ 19	+ 29
40	25	+ 15	+ 15	+ 15	+ 15	+ 25
45	28	+ 13	+ 13	+ 13	+ 13	+ 22
50	31	+ 12	+ 12	+ 12	+ 12	+ 20
55	34	+ 11	+ 11	+ 11	+ 11	+ 17,5
60	37.5	+ 10	+ 10	+ 10	+ 10	+ 15
65	41	+ 7,5	+ 8,5	+ 8,5	+ 8,5	+ 13,5
70	44	+ 5	+ 7	+ 7	+ 7	+ 12,5
75	47	+ 2,5	+ 5,5	+ 5,5	+ 5,5	+ 11
80	50	0	+ 4	+ 4	+ 4	+ 10
85	53	- 3	+2	+ 3	+ 3	+ 8,5
90	56	-6	0	+2	+2	+7,5
95	59	-10	-2,5	+1	+1	+6,5
100	62	-15	-5	0	0	+5
⁽¹⁾ The load capacity indices refer to single operations.						
Where dual tyres are fitted the second index should be used						

Record of Revision

Revision	Date	Description of Change
1	24/04/2009	
2	16/08/2010	Rearrange MOI
3	29/10/2014	New note 5 added, new table 4 added, RS 5 links updated
4	01/09/2015	Addition of Note 6 and amendment of note 3
5	20/10/2023	Revise Annex 1 to include requirements for re-treaded tyres TSE IVA N2N3 046 001
6	28/11/2025	Added Note 7 referenced from RS7.
7	11/05/2026	Rows 90 – 100 km/h added to Table 4.

This page intentionally left blank

47 Speed Limiter

Application: All Vehicles

Method of Inspection	Required Standard
<p>Ensure the vehicle is fitted with a speed limiting device or speed limitation is achieved through the actual design of the vehicle.</p> <p>Note 1: Vehicles incapable of the speed where a speed limiter is required to be set, are exempt, a confirmation (as listed below) that vehicles claiming to be incapable of 85km/h ARE incapable of it will be required:</p> <ul style="list-style-type: none"> • Documentary evidence from the manufacturer/converter that the vehicle is unable to reach the speed due to the overall gearing of the drive train, or • Documentary evidence from a speed limiter or Tachograph calibration centre, or • Exempt by nature of its use, (i.e., vehicles used by the emergency services and STGO - Abnormal Indivisible Load Vehicles with a GTW of at least 120,000kg)) or • For certain ages of vehicle exempt by certain emission approvals <p>Note 2: For the purposes of IVA, the whole of the vehicle cab is to be considered as the driver's compartment, this includes both door jambs. If fitted on a window and facing outward the details must be able to be read by a person of average height. A 'temporary' sticker is not acceptable.</p> <p>Note 3: The required set speed for the UK is 85 km/h (90 may be displayed) or 53 mph (56 may be displayed).</p>	<p>Vehicles claiming to be incapable of the speed where a speed limiter is required to be set</p> <ol style="list-style-type: none"> 1. The vehicle as presented must be accompanied by satisfactory evidence confirming that the vehicle is incapable of 85km/h (see Note 1). <p>Vehicles requiring a Speed Limiter</p> <ol style="list-style-type: none"> 2. The vehicle must be fitted with a speed limiter. 3. Speed limiter wiring must be secure, and the speed limiter device and wiring connectors must be either sealed, or require special tools to access, so as to prevent unauthorised access to adjust the settings or interrupt the power supply. 4. The speed limiter plate must be securely fitted in the driver's compartment (see Note 2). 5. The speed limiter plate must be clearly and indelibly marked with the speed at which the limiter has been set (the speed may be set in mph or km/h) (see Note 3).

Speed Limiter 47

Record of Revision

Revision	Date	Description of Change
1	24/04/2009	
2	16/08/2010	Reword MOI.
3	31/07/2011	Add text to note 1 'vehicles used by the emergency services'.
4	03/02/2014	Insert 'temporary sticker' in note 2 and remove word calibration from RS 4 & 5.
5	29/10/2014	Update exemption bullet in Note 1.
6	10/04/2018	Revise Note 2.

48A Masses and Dimensions

Application: Normal dimensions, C&U or dual plated (C&U/STGO) vehicles.

Method of Inspection	Required Standard									
<p>This inspection is to ensure that the vehicle as presented has satisfactory evidence of compliance to the required standard and has not been subject to modifications that may invalidate any approval held.</p> <p>In most cases a vehicle/trailer submitted for test will be unladen and will be obviously well within the permissible GB weights set out in the Maximum Permitted Weight Annex.</p> <p>However, if it seems likely that the vehicle/trailer or an axle (as presented) may exceed any of these weights, either weigh the vehicle/trailer or request a weight ticket.</p> <p>STGO</p> <p>Vehicles complying with the Road Vehicles (Authorisation of Special Types) (General) Order 2003 or the Motor Vehicles (Authorisation of Special Types) Order (Northern Ireland) 1997 are exempt from any of the standards which they are unable to comply with due to their special purpose.</p> <p>Plating</p> <p>A plating examination under the Goods Vehicle (Plating and Testing) Regulations 1988 must be carried out during the IVA examination unless the vehicle is exempt (as in Schedule 2 of those regulations). An IVA test pass result confirms that the provisional weights allocated on the DVSA technical record are correct. In the case of vehicles exempted from 'Plating' or intended for registration in Northern Ireland, the statutory plate prescribed in Section 18 of this manual must have two columns, one for maximum GB/NI weights, which must align to the requirements of</p>	<p>Dimensions:</p> <ol style="list-style-type: none"> The vehicle must not exceed the maximum authorised dimensions for width and length. (see Notes 1, 3, 4, 5, & Annex 1). <table border="1" data-bbox="1144 544 2092 767"> <thead> <tr> <th>Category</th> <th>WIDTH (see Annex 1)</th> <th>LENGTH (see Annex 1)</th> </tr> </thead> <tbody> <tr> <td>N2</td> <td>2550mm #</td> <td>12000mm</td> </tr> <tr> <td>N3</td> <td>2550mm #</td> <td>12000mm</td> </tr> </tbody> </table> <p># 2600mm for the superstructure of vehicles designed for transport of goods under controlled temperatures with or without equipment to maintain the interior temperature</p> <p>Masses:</p> <ol style="list-style-type: none"> In the case of a vehicle subject to Plating, the vehicle or axle weights (as presented) must not exceed the maximums authorised for the Plating certificate. In the case of a vehicle not subject to Plating, the vehicle or axle weights (as presented) must not exceed the maximums marked on the Statutory Plate prescribed in section 18 of this manual. Where the Maximum permissible trailer towing weight exceeds 3500kg or the vehicle is equipped to tow a semi-trailer, it must be verified that the vehicle has a facility to operate power brakes on the trailer. 	Category	WIDTH (see Annex 1)	LENGTH (see Annex 1)	N2	2550mm #	12000mm	N3	2550mm #	12000mm
Category	WIDTH (see Annex 1)	LENGTH (see Annex 1)								
N2	2550mm #	12000mm								
N3	2550mm #	12000mm								

Masses and Dimensions 48A

Method of Inspection	Required Standard
<p>Annex 2 of this section and one for technically permissible (design) weights if they are higher.</p> <p>Dimensions</p> <p>Check that the vehicle does not exceed the maximum authorised dimensions given in the table in Standard 1.</p> <p>Masses</p> <p>Check the requested/regulated GB weights. Where they are different to the Design Weights, two columns are required on the manufacturers plate.</p> <p>Non-Ministry plated vehicles must show two columns on the manufacturer's plate.</p> <p>Draft Ministry plated vehicles should be checked for two columns where applicable.</p> <p>Turning Circle Requirements</p> <p>Check that the vehicle is able to manoeuvre a complete circular trajectory of 360 degrees inside an area defined by two concentric circles, without any of the vehicles outermost points projecting outside the circumferences of the circles (See figure 1). This must be completed on both steering locks.</p> <p>The outer circle having a radius of 12.50 metres. The inner circle having a radius of 5.30 metres. When the vehicle is stationary facing the circle establish a vertical plane and mark this on the ground alongside the vehicle (see figure 2).</p> <p>When the vehicle enters the circle as described above no part of it shall move outside of this by prescribed limits in required standard 7. This procedure must be carried out on both sides.</p>	<p>Installation of retractable or loadable axles:</p> <p>5. If a vehicle is fitted with one or more loadable axles, satisfactory evidence must be provided stating that under all driving conditions, the axle will lower to the ground automatically when the front axle or the nearest axle of a group of axles is loaded.</p> <p>Turning Circle Requirements (see Note 2):</p> <p>6. The motor vehicle must be able to manoeuvre for a complete circular trajectory of 360 degrees within the defined area (with the exception of the protruding parts prescribed for the vehicle width shown in Annex 1) (See Figure 1).</p> <p>7. Any part of the vehicle must not move outside of the vertical plane by more than 0.8 metres. For vehicles with retractable axles in the lifted position, or loadable axles in the un-laden condition, the figure of 0,80 m is replaced by 1,00 m. (For vehicles with an axle-lift device this requirement should be checked to both requirements shown above applies with the axle(s) in the running and lifted positions) (See Figure 2).</p>

Masses and Dimensions 48A

Method of Inspection	Required Standard
<p>Note 1: Where the vehicle is clearly within the maximum, a measurement is not needed.</p> <p>Note 2: Turning Circle Requirements need not be met by vehicles with four or more axles where the distance between the foremost and rearmost axles exceeds 6.4 metres.</p> <p>Note 3: Safety railings mounted on a vehicle designed to carry at least two other wheeled vehicles are to be excluded, provided that the safety railings are more than 2m above the ground and the overall width including safety railings does not exceed 2.70m.</p> <p>Note 4: Devices for securing the tarpaulin and their projection not projecting by more than 20mm where they are no more than 2.0m from the ground level and no more than 50mm where they are more than 2.0m from the ground level. The edges shall be rounded to a radius of not less than 2.5mm.</p> <p>Note 5: Vehicles fitted with Elongated Cabs where the overall length exceeds 12m:</p> <ul style="list-style-type: none"> • The loading area length behind the cab shall be a maximum of 10.5m. • The vehicle must be marked with 96/53/EC ARTICLE 9A COMPLIANT or C&U REGULATION 7(3D) COMPLIANT on the vehicle manufacturers statutory plate. 	

Masses and Dimensions 48A

Figure 1

Vehicle must remain in between the 2 circles for a full 360 degrees

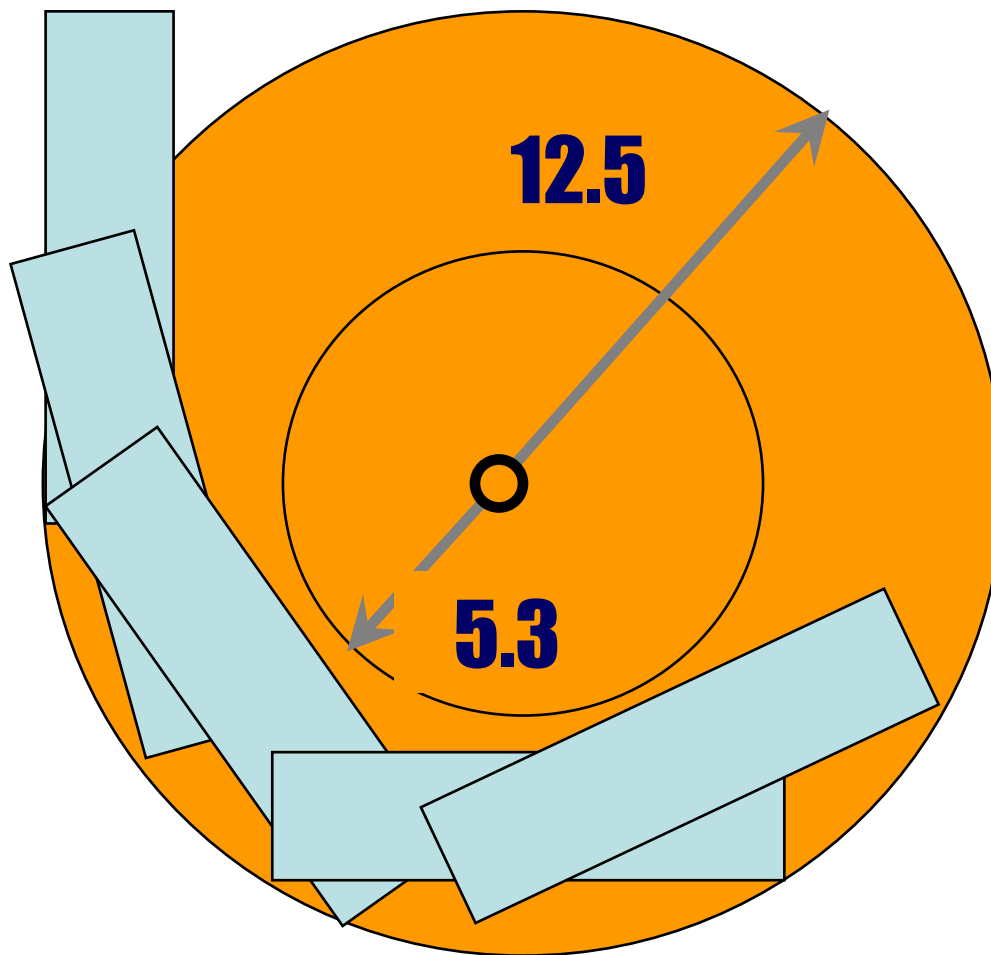

Masses and Dimensions 48A

Figure 2

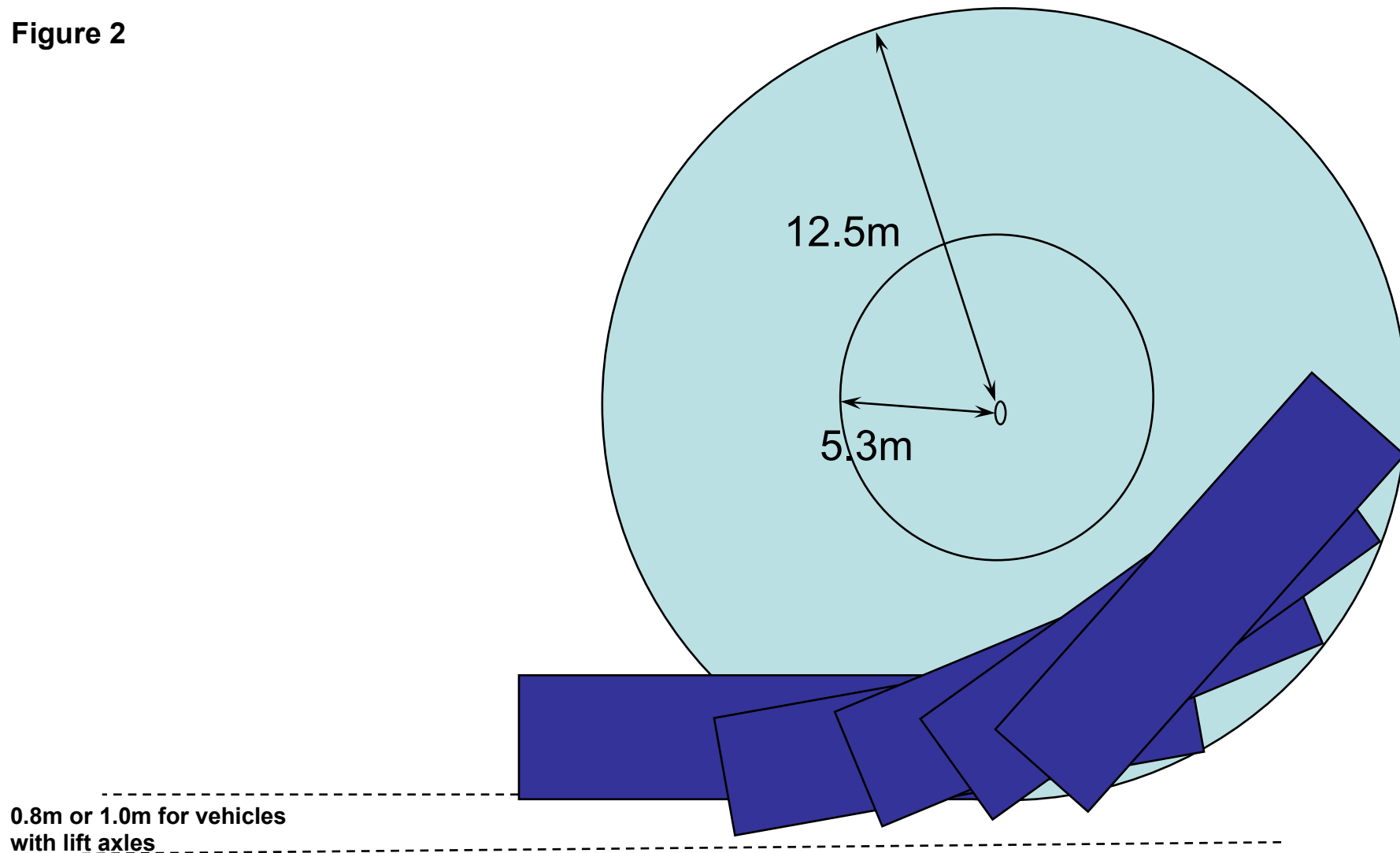

Masses and Dimensions 48A

Annex 1

Items to be excluded from measurement of length and width subject to the following

With the exception of devices for indirect vision:

- (a) where several devices are fitted to the front, the total protrusion of those devices shall not exceed **250mm**.
- (b) the total protrusion of devices and equipment added to the length of the vehicle shall not exceed **750mm**.
- (c) the total protrusion of devices and equipment added to the width of the vehicle shall not exceed **100mm**.

NOTE: Vehicle dimensions are determined by their maximum length and width. If any devices or equipment listed below exceed the permitted protrusion limits specified in Items (a), (b), & (c), they must be included in the overall measurement. The mounting position should also be considered—particularly when equipment is attached to narrower sections of the vehicle, such as the cab.

A - Items to be excluded when measuring Length	B - Items to be excluded when measuring Width
<ul style="list-style-type: none"> — wiper and washer devices. — front or rear registration plates. — lighting equipment, (extendable light bars will be allowed and they are to be excluded from the overall length measurement (in their extended position) as long as these bars do not increase the load carrying capacity of the vehicle. DVSA will not accept them if they are fitted with any device that allows the attachment of a load, i.e., twist locks. — access steps and handholds. — lifting platforms, access ramps and similar equipment in <i>running order</i> (i.e., in the position they would be on a moving vehicle), not exceeding 300 mm, provided that the loading capacity of the vehicle is not increased. --- Crane Support Legs (where fitted at rear check compatibility with RUPD). — coupling devices. — trolley booms of electrically-propelled vehicles. — external sun visors. —Antennas used for radio, navigation, vehicle-to-vehicle, or vehicle-to-infrastructure communication. --- Watching and detection aids including radars. —Aerodynamic devices. 	<ul style="list-style-type: none"> — tyre-pressure or tyre failure indicators. — protruding flexible parts of wheel guards. — lighting equipment. —access ramps, lift platforms and similar equipment (when undeployed and provided that they do not exceed 10 mm from the side of the vehicle, and the edges must be rounded to a radius of not less than 2.5 mm. The corners of any ramp facing forwards or rearwards must be rounded to a radius of not less than 5 mm). — safety railings mounted on a vehicle designed to carry at least two other wheeled vehicles, provided that the safety railings are more than 2m above the ground and the overall width including safety railings does not exceed 2.70m. — retractable steps. — the deflected part of the tyre walls immediately above the point of contact with the ground. — handles and hinges of external lockers. — trim protruding not more than 10mm from the bodywork. — Devices for securing a tarpaulin/load cover and their protection The edges shall be rounded to a radius of not less than 2,5 mm. --- Watching and detection aids including radars.

Masses and Dimensions 48A

A - Items to be excluded when measuring Length	B - Items to be excluded when measuring Width
<p>Note: Devices fitted must be type approved to (EU) 1230/2012 and must not extend the loading area. The device, when stowed, must not project beyond the rearmost point of the vehicle, except above a height from the ground of 1050mm, where a rearward projection of up to 200mm is permitted.</p> <p>—Ram rubbers.</p>	<p>— Antennas used for radio, navigation, vehicle-to-vehicle, or vehicle-to-infrastructure communication.</p> <p>—Aerodynamic devices.</p> <p>Note: Devices fitted must be type approved to (EU) 1230/2012. The vehicle width, including vehicles designed for transport of goods under controlled temperatures, shall not exceed 2600mm including the measured projections, with the devices and equipment fixed in the retracted or folded positions.</p>

Annex 2

Maximum permitted weights in Great Britain and Northern Ireland

1a Single Axle	1b Maximum Weight	Establishing GB Operational Weights Axle Weights Subject to axle configuration/spacing (Item 1a, 2a or 3a) the maximum GB axle weight is the design axle weight limited where necessary by the: <ul style="list-style-type: none"> • maximum permitted by item 1b, 2b or 3b as appropriate • maximum permitted by tyre capacity Gross Vehicle Weight (GVW) Subject to vehicle configuration (Item 4) the maximum GB GVW is the design GVW limited where necessary by the <ul style="list-style-type: none"> • maximum permitted in item 5 subject to. • maximum calculated by item 6, and the • summation of axle weights
Non driving axle	10000 kg	
Driving axle	11500 kg	
2a Tandem Axles	2b Maximum combined Weight	
Distance between axle centres is less than 1 metre	11500 kg (where at least one axle is driven) 11000 kg (no driven axles)	
1 metre and less than 1.3 metres	16000 kg	
1.3 metres and less than 1.8 metres	18000 kg or 19000 kg #	
3a Tri-axle	3b Maximum combined Weight	
Distance between any axle and the nearest axle is 1.3 metres or less	21000 kg	
Distance between any axles does not exceed 3.25 metres	24000 kg	
# Where there is one driving axle which is fitted with twin tyres and air suspension or suspension recognized as being equivalent, or where each driving axle is fitted with twin tyres and the maximum weight of each axle does not exceed 9.5 tonnes the weight of 18000 kg can be increased to 19000 kg.		
Note: Tandem axles, i.e., 2 axles in formation, either steering axles (i.e., front axles) or rear axles are to be assessed to the above requirements.		

Masses and Dimensions 48A

4 Vehicle configuration	5 Potential maximum authorised weight *	6 Potential maximum authorised weight for Alternative fuelled vehicles *	7 Potential maximum authorised weight for Zero emission vehicles *	8 Multiplication factor x Outer Axle Dimension (metres to two decimal points)
	* Subject to calculation at column 8			
Two-axle rigid	18000 kg	19000 kg	20000 kg	6000
Three-axle rigid	25000 kg	26000 kg (see Note 1)	27000 kg (see Note 1)	5500
Three axle rigid (complying with Note 2)	26000 kg	27000 kg (see Note 1)	28000 kg (see Note 1)	5500
Four or more axle rigid	30000 kgs	N/A	N/A	5000
Four or more axle rigid (complying with Note 2)	32000 kg	N/A	N/A	5000
Two-axle tractor unit	18000 kg	19000 kg (see Note 1) #	20000 kg (see Note 1) #	6000
Three or more axle tractor unit	25000 kg	26000 kg (see Note 1)	27000 kg (see Note 1)	6000
Three or more axle tractor unit (complying with Note 2)	26000 kg	27000 kg (see Note 1)	28000 kg (see Note 1)	6000

Note 1 The figure for Alternative fuel and Zero emission vehicles can be increased above the figure in column 5, **up to** the maximum specified in column 6 and 7; by a figure equal to the increase in unladen mass compared to a conventional powertrain. For example, the added mass of a battery and electric motor for a hybrid, or the increase in mass for a CNG or hydrogen tank compared to the mass of a diesel tank. The payload cannot be increased. Written evidence of the additional mass for the alternative propulsion from the manufacturer is required.

Note 2 Where the driving axle is not a steering axle and is fitted with twin tyres and air suspension or suspension recognised as being equivalent, **or** where each driving axle is fitted with twin tyres and the maximum weight of each axle does not exceed 9.5 tonnes.

Due to design weight limitations, there are circumstances where the Gross Train Weight (GTW) can be increased on two-axle tractor units, where the design GTW allows.

Masses and Dimensions 48A

PLEASE NOTE: If the vehicle axle configuration is not listed above, please contact Ellipse Technical Section for advice on the weights applicable.

9 Vehicle configuration – Artic	10 Technical Limitation	11 Maximum possible authorised Gross Train Weight (see table note 1)
Three-axle	<ul style="list-style-type: none"> • Drive axle twin tyres and road friendly suspension • Low pollution engine (i.e., Euro 2, gas or predominately gas) • Coupling Capacity 	44000 kg
Three-axle	As above but not fitted with a low pollution engine	41000 kg
Two-axle	Drive axle twin tyres and road friendly suspension	40000 kg
Two Axle	Not having a drive axle with twin tyres and road friendly suspension	36000 kg

12 Vehicle configuration – Rigid	13 Technical Limitation	14 Maximum possible authorised Gross Train Weight (see note)
Three-axle	<ul style="list-style-type: none"> • Drive axle twin tyres and road friendly suspension • Low pollution engine (i.e., Euro 2, gas or predominately gas) • Coupling Capacity 	44000 kg
Three-axle	As above but not fitted with a low pollution engine	41000 kg
Two-axle	Drive axle twin tyres and road friendly suspension	40000 kg
Two Axle	Not having a drive axle with twin tyres and road friendly suspension	36000 kg

NOTE:- Additional Train Weight limitations may apply in service depending on the specification of the trailer being towed.

Masses and Dimensions 48A

Record of Revision

Revision	Date	Description of Change
1	24/04/2009	
2	16/08/2010	Reword MOI
3	31/01/2011	Link Required Standards to correct notes and reword MOI
4	03/02/2014	Insert new note 5 and link to RS6 & 7 plus insert new exemption in Annex 1, column B
5	03/02/2014	Revise note 4 and remove reference to note 5.
6	29/10/2014	Section renumbered; Application updated
7	01/09/2015	Amend tables in Annex 2 and Annex 1
8	10/04/2018	Amend tables in Annex 2 and Section rewrite
9	01/07/2018	Add Note 3 and reference to it
10	01/09/2020	Annex 1 updated, new Note 4 referenced from RS1
11	20/10/2023	Update to RS1 table footnote to reference equipment. New Note 5 referenced from RS1 (TSE N2 N3 048-007). Revise Annex 1 'access ramps' paragraph (TSE IVA N2N3 48A 008). Added more items to length and width exemptions in Annex 1 columns A and B. Revise Table at Annex 2: Columns 4-8; new Notes 1 and 2; add 'Zero emission vehicles'.
12	28/11/2025	Annex I introductory text revised to include indirect vision devices & addition of note. Mirrors and other devices for indirect vision removed from table columns A & B. Annex II table item numbers corrected.

Masses and Dimensions 48A

This page intentionally left blank

48B Masses and Dimensions: STGO

Application: Vehicles that are Oversize, capable of STGO Cat 1, Cat 2 and/or Cat 3 operation

Method of Inspection	Required Standard															
<p>Note 1: Vehicles submitted for test will be un-laden and should be well within the permissible weights set out in Annex 2 of Section 48A. However, if it seems likely that the vehicle or an axle (as presented) exceeds any of these weights, the vehicle must be weighed where possible, or a weight ticket must be requested.</p>	<p>Dimensions:</p> <ol style="list-style-type: none"> The maximum authorised dimensions for width and length are shown below. <table border="1" data-bbox="1041 544 2107 772"> <thead> <tr> <th data-bbox="1041 544 1373 620">N3 STGO</th> <th data-bbox="1373 544 1749 620">WIDTH (see Annex 1)</th> <th data-bbox="1749 544 2107 620">LENGTH (see Annex 1)</th> </tr> </thead> <tbody> <tr> <td data-bbox="1041 620 1373 655"></td> <td data-bbox="1373 620 1749 655"></td> <td data-bbox="1749 620 2107 655"></td> </tr> <tr> <td data-bbox="1041 655 1373 691">Standard</td> <td data-bbox="1373 655 1749 691">2550mm(A)</td> <td data-bbox="1749 655 2107 691">12000mm</td> </tr> <tr> <td data-bbox="1041 691 1373 726">Large</td> <td data-bbox="1373 691 1749 726">6100mm</td> <td data-bbox="1749 691 2107 726">30000mm</td> </tr> <tr> <td data-bbox="1041 726 1373 772">Extreme</td> <td data-bbox="1373 726 1749 772">(B)</td> <td data-bbox="1749 726 2107 772">(B)</td> </tr> </tbody> </table> <p>(A) Locomotives 2750mm (B) These vehicles will be assessed on a case by case basis and can be outside of the maximum dimensions requirements of 'Large' These vehicles will be issued an IVA by VCA.</p> <p>Masses:</p> <ol style="list-style-type: none"> In the case of a vehicle not subject to Plating, the vehicle or axle weights (as presented) must not exceed the maximums marked on the Statutory Plate prescribed in section 18 of this manual (see Note 1). Where the Maximum permissible trailer towing weight exceeds 3500kg or the vehicle is equipped to tow a semi-trailer, it must be verified that the vehicle has a facility to operate power brakes on the trailer. 	N3 STGO	WIDTH (see Annex 1)	LENGTH (see Annex 1)				Standard	2550mm(A)	12000mm	Large	6100mm	30000mm	Extreme	(B)	(B)
N3 STGO	WIDTH (see Annex 1)	LENGTH (see Annex 1)														
Standard	2550mm(A)	12000mm														
Large	6100mm	30000mm														
Extreme	(B)	(B)														

Masses and Dimensions: STGO 48B

Method of Inspection	Required Standard
	<p data-bbox="1041 204 1646 231">Installation of retractable or loadable axles:</p> <ol data-bbox="1086 268 2110 402" style="list-style-type: none"><li data-bbox="1086 268 2110 402">4. If a vehicle is fitted with one or more loadable axles, satisfactory evidence must be provided stating that under all driving conditions, the axle will lower to the ground automatically when the front axle or the nearest axle of a group of axles is loaded.

Record of Revision

Revision	Date	Description of Change
1	30/09/2014	New section created
2	01/09/2015	Amendment to RS 1 regarding STGO extreme inspection

This page intentionally left blank

49 Exterior Projections of Cabs

Application: All Vehicles

Method of Inspection	Required Standard
<p>The cab area of Vehicles must not display any features likely to increase the risk of injury to other road users. This section does not apply to mirrors, their supports, or accessories such as aerials and luggage racks.</p> <p>In the case of unmodified Mass-Produced vehicles (cabs), the standards in this section shall be considered to be met.</p> <p>In considering if an item meets the requirements of this section, the examiner will compare the materials and methods used to those employed by a Major Vehicle manufacturer or to examples found on Approved vehicles. Items such as covers (rubber or otherwise) that are held in place by being stretched on or attached by double sided tape or other inadequate means, rubber hosing, pipe lagging etc. are not considered acceptable methods or materials. This is not an exhaustive list but provided as guidance as to the type of item considered to be unacceptable.</p> <p>In the case of an Armoured vehicle, exemption from one or more of the requirements is permitted where it can be demonstrated to the satisfaction of the Approval Authority that the special purpose of the vehicle makes it impossible to fully comply.</p> <p>Exterior projections will be assessed between the 'floor line' and a height of 2 metres from the ground extending rearwards to a plane passing across the rear of the cab (see note 1) and includes damaged, modified, or repaired bodywork. The theoretical floor line is determined by the series of contact points formed between the vehicle and the application of a curved area of a cone segment. The curved</p>	<ol style="list-style-type: none"> 1. A mascot, emblem or other ornamental object must retract or detach when a reasonable force is applied and leave a base or mounting free from sharp edges that does not protrude from the surface by more than 10mm. 2. All 'hard' parts contactable with a 100mm sphere, which form an external surface or protrude 5mm or more from the external surface must have a radius of curvature of at least 2.5mm. (see Notes 1, 2, 3, 4, 5, 6, & 7). <p>The criteria of Standard 2 DOES NOT apply to the following, which must be checked to their individual requirements:</p> <ol style="list-style-type: none"> 3. Protrusions less than 5mm contactable with a 100mm sphere must have blunted edges (see Notes 1 & 2). 4. Wheel arches must be 'turned inwards' or have a radius of curvature of at least 2.5mm. 5. The edges of running boards and steps must be rounded (the top surface of the step is exempt). 6. Grills, gaps, slots, grooves, channels, recesses, and holes that have a width of 10mm or less as determined by the contact points of a 100mm sphere must be blunted (see Note 8). 7. Grills, gaps, slots, grooves, channels, recesses, and holes which have a width of more than 10mm, and up to 25mm determined by the contact points of a 100mm sphere must be blunted (see Note 8).

Exterior Projections of Cabs 49

Method of Inspection	Required Standard
<p>area is at an angle of 30 degrees from the vertical. The points of contact are used as a guide to judge the actual floor line. I.e., Certain items that the cone contacts are likely to move or offer little resistance prior to detaching and are therefore excluded from the actual floor line. In addition, where the cone contacts 2 or more points and cannot contact other items that may determine the floor line a judgement will be made as to where the cone would contact the other items. Jacking points, exhaust pipes (only where the tail pipe protrudes from under the body – side mounted exhausts may actually provide the points of contact that form the floor line) and wheels are not taken into consideration when the floor line is being determined. Wheel arches are assumed to be filled in exempting any projection inboard of the turned in edge of the wheel arch. Note the floor line itself is subject to the requirements of RS2 i.e., the 2.5mm radius requirement applies.</p> <p>‘Radius’ refers to the external radius of curvature.</p> <p>‘Blunted edges’ are those which under finger and thumb pressure alone would not be likely to cut the skin.</p> <p>“Cab rear panel” means the rearmost transverse panel of the external surface of the driver and passenger compartment. Where it is not possible to determine the position of the cab rear panel it would be deemed to be the vertical transversal plane situated 50 cm to the rear of the R point of the driver’s seat, with the driver’s seat, if adjustable, located at its rearmost driving position. If the cab is fitted with more than one row of seats, the rearmost passenger seat in its rearmost position has to be taken into account for the definition of the rear cab panel. The rear panel is excluded from the requirements of this section.</p> <p>The IVA test plate (referred to in Section 4 Rear Registration Plate Space) will be placed on any number plate mountings provided. This will allow the area around the plate and its mountings to be assessed correctly.</p>	<ol style="list-style-type: none"> 8. Grills, gaps, slots, grooves, channels, recesses, and holes which have a width of more than 25mm, and up to 40mm determined by the contact points of a 100mm sphere must have a radius of curvature of at least 1mm (see Note 8). 9. Grills, gaps, slots, grooves, channels, recesses, and holes which have a width of more than 40mm determined by the contact points of a 100mm sphere must have a radius of curvature of at least 2.5mm (see Note 8). 10. Where contactable with the 100mm sphere sheet metal edges must be folded back on themselves (180 degrees). 11. Where contactable with the 100mm sphere a glass/fibre reinforced plastic panel edge must have a radius of curvature of at least 1.5mm. 12. Wiper blades and their support arms must be at least blunted. 13. Wheel nuts, hub caps and protective devices must not exhibit any fin-shaped projections. 14. Protective device(s) with a radius of curvature of at least 5mm must be fitted to wheel securing bolts, nuts, or hubs if they protrude beyond the upper half of the tyre surface. The protective devices which cover wheel nuts and hubs may project beyond the body plan by no more than 30 mm. 15. The upper half of a wheel must not protrude beyond the cab body plan form (disregarding tyres). 16. The edges on lateral air and rain deflectors and window anti-smear air deflectors, capable of being directed outwards must have a radius of curvature of not less than 1 mm.

Exterior Projections of Cabs 49

Method of Inspection	Required Standard
<p>Note 1: The measurement of a protrusion is taken from the “external surface”. The external surface is the first surface that the 100mm sphere can contact nearest to the protrusion in question. Where the sphere does not touch a surface (possibly due to the length of the projection) or contacts a further projection, a simple measurement from the projections mounting surface will be made.</p> <p>Note 2: For grab handles the projection is measured in relation to a plane passing through the points of attachment.</p> <p>Note 3: A ‘hard’ feature is a feature which has a hardness of at least 60 Shore A (as a guide, deemed to be harder than the average pencil eraser).</p> <p>Note 4: This does not apply to the couplings fitted to Abnormal Indivisible Load Vehicles (STGO), and which need only to be blunted.</p> <p>Note 5: Landing / Stabiliser Legs fitted within the cab area are not subject to the radial requirements of this section, they need only to be blunted.</p> <p>Note 6: Safety cameras fitted to vehicles for the protection of unprotected road users will not be subject to the 2.5mm radius requirements they only need to be blunted, protective shields /guards fitted for these devices are still subject to the normal criteria of the section.</p> <p>Note 7: This does not apply to the heavy-duty installation brackets/components for the fitting of specialist equipment i.e., snowplough blade which only need to be blunted.</p> <p>Note 8: The distance between parts of a grille is the distance between two planes passing through the points of contact of the sphere and perpendicular to the line joining the points of contact.</p>	<p>17. The ends of front protective devices (bumpers) must be turned inwards towards the external surface of the body.</p> <p>18. The components of bumpers projecting 5mm or more must be so designed that all rigid surfaces facing outwards have a radius of curvature of not less than 5 mm. The edges of devices projecting less than 5 mm must be blunted.</p> <p>The following Standards must be met IN ADDITION to Standard 2:</p> <p>19. Equipment such as towing hitches and winches must not protrude beyond the foremost surface of the bumper. However, winches may protrude beyond the foremost surface of the bumper provided they are covered when not in use by a suitable protective covering having a radius of curvature of not less than 2.5 mm (see Note 4).</p> <p>20. Push buttons must not protrude more than 30mm (see Note 9).</p> <p>21. Handles (other than grab handles), hinges, and fuel tank filler caps must not protrude more than 50mm.</p> <p>22. Grab handles and bonnet fasteners must not project more than 70mm.</p> <p>23. Headlight visors and rims must not project more than 30mm beyond the lens surface (measured horizontally from the point of contact of a 100mm sphere touching lens and visor/rim or the adjacent bodywork and the visor/rim if the lamp is recessed).</p> <p>24. Handles that rotate or pivot outwards must be enclosed in a protective surround or be recessed unless they cannot in any circumstance project beyond the extreme outer edge of the cab.</p> <p>25. Handles that rotate parallel to the plane of the panel must be turned inwards towards the plane of the panel.</p>

Exterior Projections of Cabs 49

Method of Inspection	Required Standard
<p>Note 9: This does not apply to Emergency Stop Buttons used by auxiliary equipment fitted to the vehicle.</p>	<p>26. The open end of any handle that rotates parallel to the plane of the panel and protrudes beyond the extreme outer edge of the cab must face rearwards.</p> <p>27. Any handle that does not protrude beyond the extreme outer edge of the cab must have:</p> <ul style="list-style-type: none"> a. The open-end facing rearwards, or b. the open end shielded to the front by a protective surround, or c. the open end recessed into the bodywork, or d. a gap measuring a maximum of 2mm between the open end of the handle and the vehicle body. <p>28. Handles that pivot outwards must have the open-end facing rearwards or downwards unless they have an independent return mechanism which in event of failure will not allow the handle to project more than 15mm.</p> <p>29. An exhaust tailpipe must not project beyond the floor line or the vertical projection of the intersection of the reference plane with the external surface of the vehicle lying directly above it by more than 10mm unless it terminates in a radius of curvature of at least 2.5mm.</p>

Record of Revision

Revision	Date	Description of Change
1	24/04/2009	
2	16/08/2010	Rearrange position of Bold Title in RS List
3	31/07/2011	Add mass produced statement to MOI, add new note 5 and link to RS21
4	29/10/2014	New note 5 and 7, with updated links, old note 5 now 6. RS 17 removed subsequent RS renumbered.
5	17/04/2015	New note 8 (Safety cameras for protection of road users)
6	01/09/2015	Addition of note 9 Ref. Snowplough mounting equipment
7	10/04/2018	Reorder notes

This page intentionally left blank

50 Couplings

Application: All Vehicles (where fitted)

Method of Inspection	Required Standard
<p>Every coupling device-must be accompanied by installation and operating instructions to ensure it is correctly installed and can be operated safely. This inspection process checks for the correct ‘e’ or “E” markings.</p> <p>An assessment must be made of the coupling load bearing structure to which the device is attached to ensure it, and any fixings are of sufficient strength. This may be by either:</p> <ul style="list-style-type: none"> • approval relevant to the vehicle, or • visual examination and assessment of the surrounding area and fixings. <p>Only automatic coupling devices (which allow an automatic coupling procedure on motor vehicles) are permitted for the coupling of trailers having a maximum mass of more than 3.5 tonnes.</p> <p>Compliance may be demonstrated by:</p> <ul style="list-style-type: none"> • A vehicle approval; or • A vehicle test report; or • An installation check <p>Note 1: Where the relevant “e” or “E” markings are not visible due to the installation method, the presenter may provide evidence that the coupling used is appropriately marked,</p> <p>Note 2: STGO - Abnormal Indivisible Load Vehicles (GTW of at least 120,000kg), the couplings are not required to be ‘e’ or ‘E’ marked</p>	<p>All Couplings</p> <ol style="list-style-type: none"> 1. If a coupling device is fitted then the vehicle must be provided with a Gross Train Weight, which must satisfy the requirements of Section 48 (masses & dimensions). 2. The coupling load bearing structure, to which the coupling is attached, and/or any fixings used, must be of sufficient strength and in accordance with the relevant approval. 3. The coupling devices must be of an approved type and have the correct markings (see Notes 1 & 2). 4. The coupling must display its load capacity. 5. The coupling must be of sufficient capacity (see Note 3). 6. The chassis and coupling manufacturer’s installation / operating instructions must be presented with the vehicle. 7. The coupling must be installed in accordance with the instructions provided, paying particular attention to: <ol style="list-style-type: none"> a. The number and grade of securing bolts required b. Whether any reinforcement of the fixing area is required 8. There must be sufficient free space around the coupling to enable the coupling to operate safely when a trailer is attached.

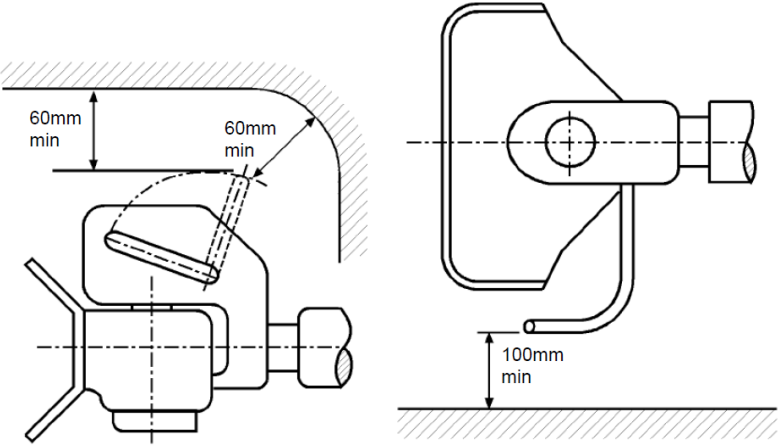
Method of Inspection	Required Standard
<p>Note 3: Satisfactory documentary evidence is required to demonstrate that the coupling is of a sufficient strength/rating to attach a trailer relevant to the displayed design train weight on the vehicle. When applicable to a 50mm ball coupling, this corresponds to the GVW plus 3,500 kg.</p> <p>Note 4: If one or more of the following standards regarding easy and safe operation (RS8/9), accessibility (RS11) or clearance for the hand lever (RS10) cannot be met; a coupling with a remote-control device must be used. Evidence of compliance with Directive 94/20/EC or Regulation 55:01 will be required.</p> <p>Note 5: If it is mounted in this area, then a coupling ball that can be dismantled without special tools has to be used.</p> <p>Figure 1</p> 	<p>Draw bar couplings</p> <ol style="list-style-type: none"> 9. A drawbar coupling must have a safe area in which a person can operate the coupling, this area must be free from any points of possible danger, any sharp edges or corners must be protected so that injury is unlikely (see Note 4). 10. The way of escape from the coupling area for draw bar couplings must be free from restriction and not be barred on either side by any attached objects (see Note 4). 11. A manually operated draw bar coupling must have sufficient clearance for the hand lever to operate easily (see Note 4 and figure 1). 12. The distance from the centre of the coupling pin to the rear of the bodywork must not exceed 420mm except: (see Note 4) <ol style="list-style-type: none"> a. providing the easy and safe actuation of the drawbar coupling is not adversely affected, this distance may be extended up to 650mm for vehicles with tipping bodies or rear mounted equipment b. or up to 1320 mm if the unobstructed height is at least 1150mm. c. Car transporters with at least two loading levels when the trailer / vehicle is not separated during normal operation may have the coupling set further back than the 420mm. 13. A remote-control device must be accompanied by satisfactory evidence of compliance (see Note 4). <p>50 mm Ball couplings</p> <ol style="list-style-type: none"> 14. Where a 50mm ball coupling is fitted the ball must not be mounted so as to obscure the place or visibility of the rear licence plate (See Note 5).

Record of Revision

Revision	Date	Description of Change
1	24/04/2009	
2	16/08/2010	Amend max height
3	31/01/2011	Replace Figure 1
4	31/07/2011	Remove original RS12 and linked table, renumber remaining RS
5	29/10/2014	New Note 4 added, linked from RS 2
6	01/09/2015	Amend note 5 and referral in RS 11 to note 5
7	10/04/2018	Add new RS2, amend MOI & reorder notes
8	28/11/2025	Note 3 revised; includes train weight applicable to a 50mm ball coupling.

This page intentionally left blank

57 Front Under-Run

Application: All Vehicles

Method of Inspection	Required Standard
<p>Ensure that the vehicle has approved / tested front under-run protection, this may be in the form of a separate front under-run device or be part of the normal structure at the front of the vehicle.</p> <p>For vehicles having a separate front under-run device ensure that an approved device is fitted and that it complies to the installation requirements found in standards 2 – 7.</p> <p>Vehicle Exemptions</p> <p>Highways surface / Geographic survey vehicles where specialist equipment prevents the fitting of devices.</p> <p>Vehicles (including Off-Road and STGO) where fitment would not be compatible with their use.</p> <p>Road Recovery Vehicles where extra ballast is fitted behind the front bumper.</p> <p>Note 1: For vehicles of category N2 not exceeding 7.5t maximum mass as an alternative to satisfactory documentary evidence, can meet the requirements for front under-run protection if:</p> <ul style="list-style-type: none"> • The ground clearance at the front of the vehicle does not exceed 400mm between two points set at not more than 200mm inwards from the outer edge of the front tyre on each side; <p>and</p> <ul style="list-style-type: none"> • Outside these points the height may increase towards the outside of the vehicle at an angle of not more than 15 degrees from the horizontal. 	<ol style="list-style-type: none"> 1. The device must be accompanied by satisfactory evidence of compliance with the required standard for “Front Under-Run Protection” (see Note 1). <p>Installation Check</p> <ol style="list-style-type: none"> 2. The device must be attached securely to the front of the vehicle. 3. The device must have a ground clearance not exceeding 400 mm. 4. The device must not extend beyond the width of the front axle (measured at the outermost part of the tyres excluding the bulging of the tyres close to the ground): 5. The device must be no shorter than the width of the front axle by more than 100 mm on either side (measured at the outermost part of the tyres excluding the bulging of the tyres close to the ground). 6. The device must be no shorter than the outermost point of the access steps of the drivers cabin by more than 200 mm on either side. 7. The device must not be bent to meet the requirements of RS 5 or 6.

Front Under-Run 57

Record of Revision

Revision	Date	Description of Change
1	24/04/2009	
2	16/08/2010	Reword Note 1
3	31/01/2011	Add exemptions to MOI
4	30/04/2012	Add more exemptions to Mol
5	29/10/2014	Add more exemptions to Mol
6	01/09/2015	Amendment to exemptions regarding STGO

62 Hydrogen Powered Motor Vehicles

Application: All Vehicles powered by hydrogen

For the information of applicants only

For the required standards for hydrogen fuelled vehicles please refer to Section 03A Fuel Tanks.

Hydrogen powered vehicles can be either internal combustion engine, with hydrogen fuel burnt in a similar way to petrol, or they can be hydrogen fuel cell, where hydrogen is converted to electricity in a chemical reaction, and the electricity powers the vehicle via an electric motor. The hydrogen can be stored (under high pressure) in compressed gas or liquefied form.

Method of Inspection

Confirm that the vehicle is a Hydrogen powered vehicle, by noting the presence of a Hydrogen fuel tank, and in the case of hydrogen fuel cell vehicle, the fuel cell and electric motor.

Record of Revision

Revision	Date	Description of Change
1	29/10/2012	New Requirement
2	29/10/2014	Reference to VOSA now DVSA
3	01/09/2020	Location of requirements updated.

65 Advanced Emergency Braking Systems (AEBS)

Application: All Vehicles subject to IVA requirements

Method of Inspection	Required Standard
<p>Ensure the vehicle or system as presented is accompanied by satisfactory evidence in the form of:</p> <p>The technical provisions of Regulation (EU) 347/2012</p> <p>or</p> <p>The technical provisions of UNECE Regulation 131</p>	<p>1. The vehicle as presented must be accompanied by satisfactory documentary evidence of compliance with the required standard for (Advanced Emergency Braking Systems AEBS)</p>
This section does not apply to:	
Semi-trailer towing vehicles of category N2 with a maximum mass exceeding 3,5 tonnes but not exceeding 8 tonnes	
Off-road vehicles of categories N2 and N3	
Special purpose vehicles of categories N2 and N3	
Vehicles of categories N2 and N3 with more than three axles.	
A completed vehicle where the complete or incomplete vehicle it is based upon was manufactured before 1 September 2018.	
A complete vehicle, which was manufactured before 1 September 2018.	
A completed vehicle where the complete or incomplete vehicle upon which it is based has a gross weight not more than 8 tonnes or has hydraulic brakes or is not	

Advanced Emergency Braking Systems (AEBS) 65

Method of Inspection	Required Standard
<p>equipped with pneumatic rear suspension; and was manufactured before 1 November 2020.</p>	
<p>A complete vehicle having a gross weight not more than 8 tonnes or has hydraulic brakes or is not equipped with pneumatic rear suspension; and which was manufactured before 1 November 2020.</p>	
<p>Completed vehicles based on a complete or incomplete vehicle of category N1.</p>	
<p>Vehicles built by a manufacturer which made fewer than 1,000 chassis and unitized bodies in the previous calendar year.</p>	

Record of Revision

Revision	Date	Description of Change
1	01/07/2018	Section added

This page intentionally left blank

66 Lane Departure Warning Systems (LDWS)

Application: All Vehicles subject to IVA requirements

Method of Inspection	Required Standard
<p>Ensure the vehicle or system as presented is accompanied by satisfactory evidence in the form of:</p> <p>The technical provisions of Regulation (EU) 351/2012, or The technical provisions of Regulation UNECE 130</p> <p>This section does not apply to:</p> <p>Semi-trailer towing vehicles of category N2 with a maximum mass exceeding 3,5 tonnes but not exceeding 8 tonnes.</p> <p>Off-road vehicles of categories N2 and N3.</p> <p>Special purpose vehicles of categories N2 and N3.</p> <p>Vehicles of categories N2 and N3 with more than three axles.</p> <p>A completed vehicle where the complete or incomplete vehicle upon which it is based was manufactured before 1 September 2018.</p> <p>A complete vehicle, which was manufactured before 1 September 2018.</p> <p>Completed vehicles based on a complete or incomplete vehicle of category N1 or M1.</p> <p>Vehicles built by a manufacturer which made fewer than 1,000 chassis and unitised bodies in the previous calendar year.</p>	<ol style="list-style-type: none"> 1. The vehicle as presented must be accompanied by satisfactory documentary evidence of compliance with the required standard for (Lane Departure Warning Systems LDWS).

Lane Departure Warning Systems (LDWS) 66

Record of Revision

Revision	Date	Description of Change
1	01/07/2018	New section.
2	11/05/2026	Correction of RS number.

69 Electrical Safety

Application: Vehicles equipped with one or more traction motor(s) operated by electric power

Method of Inspection	Required Standard
<p>This section should be read in conjunction with the required standards set out in General Construction.</p> <p>See Glossary of Terms for a definition of a Hybrid Electric Vehicle.</p> <p>Ensure the vehicle or system as presented is accompanied by satisfactory evidence in the form of:</p> <ul style="list-style-type: none"> • Original mass-produced vehicle approval to ECE R100.01 or • A test report to ECE R100 witnessed by the Approval Authority (VCA) or Authorised Technical Service • A Model Report created by TASS <p>and in these cases, a Visual Inspection is required.</p> <p>In the case of unmodified Mass-Produced Vehicles, the standards in this section shall be considered to be met. Where evidence suggests that the vehicle has been modified, the Examiner shall assess whether the modification would be likely to materially affect the performance of the relevant component or system, and if so, carry out assessment against the RS. Conversions that are not based on N2/N3 vehicles may comply with the applicable requirements of the original base vehicle. Documentary evidence of base or incomplete vehicle approvals will be deemed acceptable.</p> <p>Note 1: The use of stretchy or soft coverings over high voltage terminals is strictly forbidden.</p>	<ol style="list-style-type: none"> 1. The vehicle as presented must be accompanied by satisfactory documentary evidence of compliance with the required standard for (electric vehicles). <p>Visual Inspection</p> <ol style="list-style-type: none"> 2. All high voltage cable terminations must be suitably protected; these protections (solid insulator, barrier, enclosure, etc.) shall not be able to be opened, disassembled or removed without the use of tools (see Note 1). 3. Any enclosure carrying high voltage shall be clearly marked with an indelible label (see figure 1) affixed in a visible location. 4. All visible high voltage cables must be orange in colour. 5. All metal enclosures with internal high voltage must have an earth path for protection against electrical shock (this may be a separate bonding or the mounting arrangement where it does not isolate the enclosure).

Electrical Safety 69

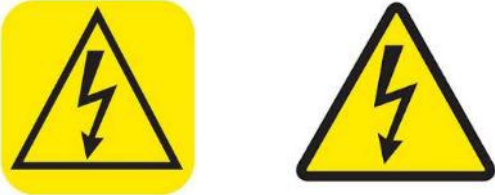
Method of Inspection	Required Standard
<p data-bbox="161 226 282 261">Figure 1</p> 	

Record of Revision

Revision	Date	Description of Change
1	03/02/2014	New Section
2	01/07/2018	Amend MOI and remove information only label
3	20/10/2023	Section renamed to match RV(A)R 2020, application clarified, reference to glossary added to MOI. Removal of RS3 & re-numbering of remaining RS. TSE IVA N2N3 069 001
4	28/11/2025	Paragraph added to Mol to clarify acceptance of unmodified mass-produced vehicles (TSE IVA N2N3 069 002).

This page intentionally left blank

General Construction

Application: All Vehicles subject to IVA requirements

Method of Inspection	Required Standard
<p>The following section assesses the vehicles suitability for use under all normal operating conditions, including when it is laden to its maximum permitted axle/gross vehicle weight and considers the effects of vibrations and the forces imposed by its design speed, acceleration characteristics, braking and cornering. The vehicle must at all times present no danger to the occupants or other road users.</p> <p>All components and attachment methods will be compared to those employed on ECWVTA vehicles. This does not prevent a manufacturer utilising other construction methods or materials providing they offer at least the equivalent performance of those employed on an approved vehicle.</p> <p>Note 1: A television monitor which can be seen from the driving position and capable of operation when the vehicle is in motion is not acceptable, unless it provides visibility to the rear of the vehicle, a navigation map, vehicle specific information or a combination of these items.</p> <p>Note 2 This assessment includes the attachment of any component/assembly of any structure, the strength and suitability of materials used, (including pipes etc.), all fastenings, (welding, brazing, bonding, rivets, nuts, and bolts etc.) are to be assessed for suitability, completeness, and security.</p> <p>Note 3 When assessing a component for leaks the original design of the component will be taken into consideration.</p>	<ol style="list-style-type: none"> 1. All aspects of the design and construction of the vehicle must be such that no immediate danger is caused or likely to be caused to any person in the vehicle or to other road users (see Note 1). 2. When driven, the safe control of the vehicle must not be impaired or likely to be impaired, due to a design or construction feature or characteristic. 3. The vehicle structure and all components including their attachment must be suitable and of adequate strength (see Note 2). 4. A transmission/braking component which rotates during vehicle operation, electrical component, steering or suspension component, wheel or tyre must not foul on another component, or be likely to foul under normal operating conditions. 5. Fuel and electrical components must not be subject to either a corrosive environment or be exposed to heat sources likely to cause premature failure. 6. All steering, suspension, brake, and fuel system components must not be leaking (see Note 3). 7. All electrical cables/wires must be free from chaffing and secured at intervals of at least every 300mm unless contained in a secure hollow component (see Note 4). 8. All electrical components must be secure, be of adequate capacity, and be insulated as required as to prevent short circuiting during operation.

General Construction

Method of Inspection	Required Standard
Note 4: This does not apply to control leads (fly leads) used on specialised equipment, i.e., power ramps and lifts.	

Record of Revision

Revision	Date	Description of Change
1	24/04/2009	
2	16/08/2010	Add note 4 and link to RS7
3	31/01/2011	Clean up text in MOI

This page intentionally left blank

Glossary of Terms

Abnormal Indivisible Load vehicle

A vehicle specially designed and constructed, and used only for, or empty in connection with, the conveyance of abnormal indivisible loads.

Air Bag

A flexible bag fitted to a vehicle designed to be filled with gas under pressure in order to protect the driver or front seat passenger in the event of a collision involving the front of the vehicle.

Alternative Fuel

A fuel or power source which serves, at least partly, as a substitute for fossil oil sources in the energy supply to transport and which has the potential to contribute to its de-carbonisation and enhance the environmental performance of the transport sector, consisting of—

- (a) electricity consumed in all types of electric vehicles;
- (b) hydrogen;
- (c) natural gas, including biomethane, in gaseous form and liquefied form;
- (d) liquefied petroleum gas;
- (e) mechanical energy from on-board sources, including waste heat;

Alternatively Fueled Vehicle

A motor vehicle powered wholly or in part by an alternative fuel and which has been approved under the “Framework Directive.”

Armoured Vehicle

A vehicle intended for the protection of conveyed passengers and/or goods and complying with armour plating anti-bullet requirements. "Anti-bullet requirements" shall be interpreted as meaning; the driver and passenger compartment (front, rear and sides including doors and glazing are capable of withstanding ballistic penetration from small arms fire. e.g., materials to EN 1063 or an equivalent level of protection.

Approval Authority

The Vehicle Certification Agency is the UK Approval Authority,

Auxiliary engine

An engine not used to propel the vehicle but to drive engineering plant equipment on the vehicle.

Blunted Edge

An edge not likely to cause injury whatever the circumstances under finger/thumb pressure (contact is not likely to puncture the skin).

Cab Plan Form

The area resulting from the vertical projection of the front and sides of the cab area only onto a horizontal surface. For the purposes of this definition “cab area” means all parts of the bodywork and chassis, of the cab only, including any separate wheel guards but not including running gear such as wheels, axles, suspension, brakes, and steering.

CNG

Compressed Natural Gas.

Coupling Class

Class A = Coupling balls and towing brackets

Class B = Coupling heads

Class C = Automatic drawbar couplings

Class D = Drawbar eyes

Class G = Fifth wheel Couplings

Class H = Fifth wheel pin

Class S = Devices and components which do not conform to any of the Classes A to H above and which are used, for example, for special heavy transport or are devices unique to some countries and covered by existing national standards.

Date of Manufacture

In the case of an Amateur Built Vehicle is, unless otherwise stated in the regulations or Inspection Manual:

- the date on which the vehicle is presented for examination; or
- a date prior to the date the vehicle is presented for examination if there is conclusive evidence the vehicle was completed and included all the parts which it needs to comply with the prescribed requirements and was in such a condition as to be acceptable to test on that date.

Designated Seating Position

A position where there is a seat designated for normal use while the vehicle is travelling on the road.

Devices for Indirect Vision

Devices intended to give a clear view of the rear, side, or front of the vehicle within the fields of vision defined in Figures 1 & 2 at Section 08 of the N2 & N3 IVA Inspection Manual. These can be conventional mirrors, camera-monitors, or other devices able to present information about the indirect field of vision to the driver.

Glossary of Terms

Disabled Person's Belt

A seat belt which has been specifically designed or adapted for use by an adult or young person suffering from some physical defect or disability and which is intended for use solely by such a person.

Double Glazing

An assembly of two glazing panes permanently assembled in manufacture and separated by a uniform gap.

Double Windows

Two separate units installed in a vehicle as separate inner and outer panes.

Emergency vehicle

An **emergency vehicle** is any vehicle that is designated and authorized to respond to an emergency in a life-threatening situation. These vehicles are usually operated by designated agencies, often part of the government, but also run by charities, non-governmental organisations and some commercial companies.

Extreme outer edge

In relation to the side of a vehicle, the vertical plane parallel with the longitudinal axis of the vehicle and coinciding with its lateral outer edge, disregard the projection of;

- a. distortion of any tyre due to the weight of the vehicle
- b. connections for tyre pressure gauges
- c. anti-skid devices mounted on the wheels
- d. rear view mirrors
- e. lamps and reflectors
- f. custom seals and devices for securing and protecting such seals
- g. special equipment (**as listed in Annex 1 section 48**)
- h. in respect of Section 49 (Exterior Projections) only: windows, handles, hinges, push buttons and fuel tank filler caps.

Front under-run protection

Means the presence at the front of the vehicle of either:

A special front under-run protection device; or

Body work, chassis parts or other components, such that by virtue of their shape and characteristics, these elements can be regarded as fulfilling the function of the front under-run protection device.

Forward control vehicle

A vehicle with the configuration in which more than half of the engine length is rearward of the foremost point of the windshield base and the steering wheel hub in the forward quarter of the vehicle length.

Harness Belt

An adult belt which is a harness belt comprising a lap belt and shoulder straps.

Indivisible load

Shall mean a load that cannot, for the purpose of carriage by road, be divided into two or more loads without undue expense or risk of damage.

Hard Parts

Parts made of a material of hardness exceeding 60 shore A.

Hybrid Electric Vehicle (HEV)

A vehicle, including vehicles which draw energy from a consumable fuel only for the purpose of recharging the electrical energy/power storage device that for the purpose of mechanical propulsion draws energy from both of the following on-vehicle sources of stored energy/power:

- (a) A consumable fuel;
- (b) A battery, capacitor, flywheel/generator, or other electrical energy/power storage device.

In Running Order

In relation to the vehicle weight, means

- with all fluids (such as oils and engine coolant) necessary for the vehicle to be driven, the fuel tanks full, a spare wheel and tool kit
- carrying a driver weighing 75kg but no other passenger or load.

Illuminating Surface

Should be taken to be the area of the “reflector” to the rear of the bulbs. Where lamps are mounted in a common housing and are “E” marked, the separation criteria should be assumed to be met.

Insecure

A component or its fixing is, due to its design or a construction feature, not completely attached to the vehicle structure or to another associated component as intended.

Lap Belt

A seat belt which passes across the front of the wearer’s pelvic region, and which is designed for use by an adult.

Glossary of Terms

Lifting Axle

'Lifting axle' means an axle which can be lifted from the road during normal trailer use.

Locomotive

Vehicles not constructed or adapted to carry a load or passengers except water/fuel/batteries/tools. Light locomotive 7370 – 11690kg. Heavy locomotive exceeding 11690kg, e.g., Mobile cranes, fixed plant or agricultural.

Longitudinal Plane

A vertical plane parallel to the longitudinal axis of the vehicle.

LPG

Liquid Petroleum Gas.

Major Manufacturer

A vehicle manufacturer that produces vehicles approved to EC Whole Vehicle Type Approval standards.

Manufacturer's Plate

A piece of durable material e.g., metal or plastic that is likely to last the life of the vehicle and which is permanently marked with the required markings.

Matched Pair

For the purpose of this manual only:

Lamps fitted to the vehicle must be of the same brightness, intensity, colour, shape, height, position, and beam pattern.

Obvious modification

Where evidence suggests that the vehicle / component has been modified which invalidates the approval, evidence must be easily recognisable without the need of a detailed inspection.

Off-Road VehicleVehicles in Category N2

Are to be considered to be off-road vehicles either if the wheels are designed to be driven simultaneously, including vehicles where the drive to one axle can be disengaged; or

If the following three requirements are met

- 1) At least one front and at least one rear axle are designed to be driven simultaneously, including vehicles where the drive to one axle can be disengaged.
- 2) There is at least one differential locking mechanism or at least one mechanism having a similar effect.
- 3) They can climb a 25% gradient calculated for a solo vehicle.

Vehicles in category N3

Are to be considered to be off-road vehicles either if the wheels are designed to be driven simultaneously, including vehicles where the drive to one axle can be disengaged; or

If the following requirements are satisfied:

- At least half the wheels are driven,
- There is at least one differential locking mechanism or at least one mechanism having a similar effect,
- They can climb a 25 % gradient calculated for a solo vehicle,
- At least four of the following six requirements are satisfied:
 - 1) The approach angle must be at least 25°,
 - 2) The ramp angle must be at least 25°,
 - 3) The ground clearance between the axles must be at least 300 mm,
 - 4) The departure angle must be at least 25°,
 - 5) The ground clearance under the front axle must be at least 250 mm,
 - 6) The ground clearance under the rear axle must be at least 250 mm.

Production Vehicle

A vehicle of a make, model and type, mass produced by the vehicle manufacturer.

Radius

Refers to the external radius of curvature.

Rain flap

'Rain flap' means a flexible component mounted vertically behind the wheel, on the lower part of the chassis or the loading surface, or on the mudguard.

Seat Displacement Device

A device to permit forward tipping of a seat or the back rest to fold down.

Servo Assisted

A system where the muscular energy of the driver is supplemented by another energy source.

Stairway

A passageway incorporating a flight of steps, from one floor or level to another.

Glossary of Terms

Unladen weight

The unladen weight of any vehicle is the weight of the vehicle excluding passengers, goods, or other items. It includes the body and all parts normally used with the vehicle or trailer when in use on the road but does not include the weight of the fuel or, if an electric vehicle, the batteries.

Vehicle cab

Constitutes the driver and passenger compartment, including the doors.

Zero emission vehicle (ZEV)

A vehicle without an internal combustion engine, or with an internal combustion engine that emits less than 1g CO₂/kWh as determined in accordance with Regulation (EC) No 595/2009 and its implementing measures.

Record of Revision

Revision	Date	Description of Change
1	24/04/2009	
2	16/08/2010	Add definitions
3	31/01/2011	Add definition of Approval Authority
4	29/10/2014	Minor revisions
5	01/09/2015	Minor revisions
6	10/04/2018	Revision to definition of major manufacturer, Add definition of forward control vehicle & Emergency vehicle, revision to extreme outer edge definition
7	20/10/2023	Definition of Hybrid Electric Vehicle & Zero emission vehicle added

Glossary of Terms



Driver & Vehicle
Standards
Agency

Contact us

DVSA
Berkeley House
Croydon Street
Bristol
BS5 0DA

www.gov.uk/dvsa

Telephone

0300 123 9000

[Find out about call charges](#)

Monday to Friday - 7.30am until 6.00pm (normal working hours)