



Driver & Vehicle  
Standards  
Agency

# Public Service Vehicle (PSV) Inspection Manual



Keeping Britain moving,  
safely and sustainably

## Public Service Vehicle Revision Record

Section Number	Section Title	Description of Change	Revision Date
	About this Manual	Page 3 of 3 – Scope of Inspections – Added to paragraph in respect of regulatory requirements which update this manual compared with type-approval.	01/04/2025
	Interpretation of Terms	Page 2 added Note: Fuel tanks and gas cylinders will only be subject to visual inspection for corrosion.	01/04/2025
7	Size and Types of Tyres	Page 9 of 9 – Deficiency 1a (ii) After the words ‘axle weight and is loaded’ new wording is added which states ‘at least 10%’.	01/04/2025
16	Passenger Doors, Drivers Doors and Emergency Exits	Page 3 of 5 – Added to paragraph in respect of ‘Tethered brake glass hammers’, new wording includes requirements for Bus Directive and ECE Regulation Vehicles.	01/04/2025
16	Passenger Doors, Drivers Doors and Emergency Exits	Page 3 of 5 – Added new paragraph in respect of ‘The minimum requirements for an emergency door, window or roof hatch’, new paragraph 3 includes requirements for Bus Directive and ECE Regulation Vehicles.	01/04/2025
21	Interior of Body, Passenger Entrances, Exit Steps and Platforms	Page 2 added A fire extinguisher must be maintained in good efficient working order.  <b>Where a gauge is fitted to a fire extinguisher</b> the reading shown should not be used to determine the condition of the extinguisher	01/04/2025
23	Glass and View to the road	Page 3 added Monitors for indirect vision devices	01/04/2025
45	Fuel Tanks and Systems	Page 1 – Application, Hydrogen fuel cell tanks to be considered fuel tanks. Page 1 – Procedure and Standards, paragraph added for LPG, CNG, LNG and Hydrogen tanks now testable. Page 2 – RFR added for these tanks being excessively corroded and/or damaged.	01/04/2025
59	Brake Systems and Components	Page 1 added words in bold. A pipe with its wall thickness reduced by more than one third of its original thickness is considered <b>a major or dangerous deficiency depending upon severity.</b>	01/04/2025
Section Number	Section Title	Description of Change	Revision Date
00	About This Manual	Page 3 - manual sections that have been updated are shown with a black vertical line in the margin.	01/04/2026
	Interpretation of Terms	Page 5 – paragraph added to define adapted driver’s controls.	01/04/2026
	List of Inspections	Changed title of IM 74 to other dangerous defects and conditions.	01/04/2026

## Public Service Vehicle Revision Record

1	Registration Plate	Re-write of section to incorporate font type, size and spacing.	01/04/2026
6	Road Wheels and Hubs	Page 1 – paragraph added to bolster the requirement for wheel embellishers and nut covers to be removed before test.	01/04/2026
7	Size and Type of Tyres	Page 1 – sentence added to verify non genuine load indexes. Page 1 – verifies what to do if a load index cannot be found (scrubbed off).	01/04/2026
16	Passenger Doors, Driver door and Emergency Exits	Page 1 – clarify where power operated doors should be opened from. Page 1 – paragraph updated to check door safety systems with DVSA supplied tool. Page 2 – define deficiency for where no gap exists between advert/film and bonding/frame. Page 2 – removed: <b>For power operated doors fitted with safety systems</b> to prevent passengers from being trapped. If the vehicle has double leaf type doors the dimension where the doors should stop and reopen should be taken for each door separately.	01/04/2026
21	Interior of Body, Passenger Entrances, Exit Steps and Platforms	Page 1 – further define where accessibility certificate applies to IM24. Page 2 – added in fire extinguisher gauge check. Page 2 – added in (if fitted to a bus with an accessibility certificate or a special authorisation examine under Inspection Manual item 24) to top 2 bullets.	01/04/2026
24	Accessibility Features	Page 1 – “Application” added in where IM 24 does not apply to 22 or fewer passengers.	01/04/2026
26	Speedometer/Tachograph	Page 1 – paragraph added to show the procedure for snap off tacho seals which have not been snapped off. Page 2 – section added for digital tacho printouts and how to identify calibration dates and what order to select them. Page 3 – added “depleted roll” into first paragraph and changed leaving site to test concluded. Page 4 – 2 new deficiencies added to align with new paragraph for snap off seals.	01/04/2026
33	Speed Limiter	Page 3 – changed her majesty to his majesty.	01/04/2026
38	Service Brake Operation	Page 1 – Procedure and standards amended, inspection procedure added for air pressure, vacuum, hydraulic and full pressure hydraulic systems. Page 2 – new paragraph to state what to do with modern vehicles with multifunction displays where MILs may not carry out a system check.	01/04/2026
67	Aim of Headlamps	Page 1 – clarify that any adjustments outside of cab adjuster will be a deficiency.	01/04/2026
74	Other Dangerous Defects and Conditions	Changed heading to “other dangerous defects and conditions”. Re-write of section to define what a condition is and give examples. Changed deficiency text adding “condition”.	01/04/2026

# Public Service Vehicle Inspection Manual

## About this Manual

### Purpose

This manual explains to everyone engaged in the practical work of vehicle examination and maintenance:

- The application of specific relevant requirements.
- The procedures and standards to be used.
- The deficiencies.
- The deficiency categorisation.

The manual is not a legal interpretation of Regulations, nor does it necessarily lay down standards for rejection elsewhere.

### Layout of Inspection Manual

The page layout for each inspection item consists of an Application section; this section will contain the application criteria. Following this will be the Procedure and Standards section where any procedures specific to the section will be contained as well as any notes relevant to the standards to apply. The remainder of the page(s) will be split between the Deficiency and the Deficiency Category columns.

### Procedures

The procedures given here assume that only parts of a vehicle which can readily be seen without dismantling are to be examined. However, it may be necessary to ask the driver to remove wheel embellishers or panels where it is not otherwise possible to inspect safety critical items.

### Minimum Standards

It must be emphasised that these are minimum acceptable standards, which do not necessarily allow for further deterioration when the vehicle is in service.

## About this Manual

### Deficiency Categorisation

Deficiencies found during the test shall be categorised in one of the following groups:

- Minor – deficiencies having no significant effect on the safety of the vehicle/trailer or impact on the environment and other minor non-compliances. If only defects of a minor nature are present, a pass must be recorded.
- Major – deficiencies that may prejudice the safety of the vehicle, have an impact on the environment, put other road users at risk or other more significant non-compliances.
- Dangerous – deficiencies constituting a direct and immediate risk to road safety or having an impact on the environment.

### Acceptance For Test

Conditions for accepting vehicle for test include:

- The vehicle chassis number must be permanently fixed to the vehicle in an accessible, easy to read, position.
- The vehicle must be clean enough to allow the component parts to be inspected.
- The vehicle must not present a health and safety hazard to inspect.

If you are in doubt regarding any of the above, it is recommended that you contact the Driver and Vehicle Standards Agency Contact Centre for advice.

### The Inspection

Each inspection has been allocated a number, which is given at the top of the page.

Not all inspection numbers have been allocated.

The requirements of each inspection will be found in Schedule 2 of The Motor Vehicle (Test) Regulations 1981 as amended.

### After The Test

On completion of the test, copies of the smoke test and brake test reports should be issued, together with (if applicable) a refusal to issue a certificate. The refusal will refer to the deficiencies identified, which are considered to be below the minimum standard.

## About this Manual

### Assessment of Component condition

It is not practicable to lay down limits of wear and tolerances for all types of components on different models of vehicle, or to define acceptable amounts of damage, deterioration and effectiveness. Testers are therefore expected to use their knowledge, experience and judgement in assessing whether the condition of a component has reached the stage where it is obviously adversely affecting its functionality or likely to adversely affect the roadworthiness of the vehicle.

### Scope of Inspections

The scope of the inspections in this manual does not cover all the requirements of The Road Vehicles (Construction and Use) Regulations and The Road Vehicles Lighting Regulations. It may be noted that some standards in this inspection manual may differ from that of type-approval, this is because this manual is covered and updated under different regulations.

### Health and Safety

Drivers presenting vehicles for test must follow the instructions given by Driver and Vehicle Standards Agency staff. Radios and telephones must not be used whilst vehicles are undergoing test.

### Manual Section Updates

A black vertical line in the margin of the manual page, indicates a change to either the test procedure and standards, or a deficiency.

## Interpretation of Terms used in the Manual

### **Annex VII**

This means Annex VII to the Bus Directive 2001/85/EC and 'Annex VII vehicle' means a Bus Directive vehicle required to comply with Annex VII.

### **Articulated Bus**

An articulated bus is one, which can be divided into two or more parts normally by the use of workshop facilities. Passengers can move freely from one part of the bus to the other.

### **Automatically Operated Service Door**

'Automatically operated service door' means a power operated service door which can be opened (other than means of an emergency controls) only after a control is operated by a passenger and after activation of the controls by the driver, and which close again automatically.

### **Bus Directive Vehicle**

This means a bus or coach which meets the requirements of the Bus Directive EC/2001/85. The vehicle may have a full type approval or may have been inspected to the required directive. The technical print for the vehicle will indicate "Bus Directive" vehicle.

### **Coach**

A large bus with a maximum gross weight of more than 7500kg and a maximum speed exceeding 60m.p.h.

### **Corrosion**

The effect of corrosion on the safety of the vehicle depends on:

- Its extent.
- The function of the section on which it has occurred.

A small amount of corrosion on an important part of the vehicle structure can make a vehicle unsafe where it destroys the continuity of the load bearing structure.

On the other hand, heavy corrosion of unimportant sections may have no effect on the vehicle safety.

## Interpretation of Terms used in the Manual

### Corrosion Assessment

The inspection should determine whether excessive corrosion exists first by visual inspection and then by finger and thumb pressure.

If necessary careful scraping or light tapping of the area is permitted.

Corrosion affected heavy gauge metal may be tapped harder than light gauge, but unwarranted force and damage must be avoided.

### Corrosion Failure Criteria

Any part of a load bearing member or load bearing panelling should be refused if it is weakened by corrosion to the extent that:

- By finger and thumb pressure it does not feel rigid, or
- It crumbles to leave a hole, or
- When tapped there is penetration, or it causes the metal to crumble or disintegrate.

**Note:** Fuel tanks and gas cylinders will only be subject to visual inspection for corrosion.

### Cracked

A flaw or split in a component.

### Damage

When assessing the extent of damage, it is important to consider whether the performance of the component/system will be impaired or if the component/system is likely to fail prematurely.

Damage fulfilling either of these criteria is not acceptable and will be a deficiency.

### Deteriorated

This will be a deficiency if the component or system is weakened to such an extent that it can no longer adequately perform its function.

### DGVW

Design Gross Vehicle Weight – the maximum gross weight a vehicle was designed to operate at by the manufacturer.

### Distorted

This will be a deficiency if the component or system is distorted to such an extent that it can no longer adequately perform its function.

### ECE Regulation vehicle

This means a bus which has been built or approved to Directive 2001/85/EC, ECE regulation 36 (buses with more than 22 passengers), ECE regulation 52 (buses with not more than 22 passengers) or ECE regulation 107 (Double Deck buses). This will also include vehicles built or approved from 29th October 2010 to ECE Regulation 107.2 (IVA, NSSTA & ECWVTA).

# Public Service Vehicle Inspection Manual

## Interpretation of Terms used in the Manual

### **EV (Electric Vehicle)**

A vehicle that is powered by electric power train only. A vehicle with a hydrogen fuel cell should be considered an electric vehicle.

### **Excessive travel**

An abnormal amount of movement which clearly indicates that a component has reached a stage when it requires remedial action to enable it to either:

- a. operate effectively as designed, or
- b. prevent it from reaching the end of its permitted travel, or
- c. prevent it from exceeding manufacturer's known maximum permitted limits.

### **Excessive wear**

A component which is worn to such an extent that it is either:

- a. likely to fail, or
- b. clearly not functioning effectively as designed, or
- c. visibly worn beyond manufacturers' known permitted limits, or
- d. likely to affect the operation or condition of another safety related component.

### **First use dates**

Throughout this manual we have used the terms "before" and "from" when referring to first use dates. The term "from" should be regarded to be on or after a certain date. Where there is a first use date quoted for a motor vehicle this will not normally apply if the vehicle was built more than 6 months before that date.

### **Fouling**

This will only be a deficiency if contact of two parts is likely to cause damage to or restrict the movement of a component.

### **Fractured/broken**

Gap, opening or rupture where separation has taken place.

### **Front steered axle**

Any axle(s) deemed to be forward of the chassis midpoint and directly controlled by the motor vehicle steering system.

# Public Service Vehicle Inspection Manual

## Interpretation of Terms used in the Manual

### **HEV (Hybrid Electric Vehicle)**

A vehicle powered by a power train that consists of both an internal combustion engine and an electrical energy/power storage device.

### **Inappropriate Modification**

A modification to a component which stops or severely affects the functionality of the component (also see unsafe modification).

### **Insecure**

The term “insecure” is used many times throughout this manual to describe a defective condition. This term should be taken to mean either:

- a component has relative movement (looseness) at its fixings where there should be none, or
- a component has relative movement (looseness) to an associated component where there should be none, or
- a safety critical component is not safely or completely attached at its fixing or to an associated component.

Certain components, such as wheel studs/nuts, body mountings etc. have specific criteria detailed in the inspection manual.

### **Large Bus**

A vehicle constructed or adapted to carry more than 16 passengers in addition to the driver.

### **Minibus**

A motor vehicle which is constructed or adapted to carry more than 8 but not more than 16 seated passengers in addition to the driver.

### **Obligatory/Mandatory**

Required to be fitted by law.

### **Schedule 6**

Where a requirement in this manual refers to Schedule 6 minibus this means a minibus first used from 1 April 1988.

### **Service Door**

Means a door intended for use by passengers in normal circumstances with the driver seated.

## Interpretation of Terms used in the Manual

### **Type Approved**

A component or system fitted to a vehicle which has been issued with a Type Approval Certificate or Certificate of Conformity which shows that the system or component complies with the requirements of an EU Directive or ECE regulation.

If the presenter claims that the vehicle is fitted with type approved equipment which complies with the requirements of an EC directive and has no documentary evidence, consideration must be given to the following:

- annual test standards should not exceed those of type approval
- does the component or system appear to have been modified, replaced or damaged
- Where doubt exists, the benefit should be given to the presenter.

### **Unsafe Modification**

Modifications to vehicles must be assessed on their merits, taking account of the nature of the modification and whether the component is safety critical.

The main criteria to be used are:

- whether the modification adversely affects the roadworthiness of the vehicle, or
- is likely to cause injury (such as modification to the body), or
- has a disproportionately adverse effect on the environment.

### **Vehicle category (Definition used in the Community Directive)**

**Category M2:** Vehicles used for the carriage of passengers and comprising of more than eight seats in addition to the driver's seat and having a DGVW **not** exceeding 5000kg.

**Category M3:** Vehicles used for the carriage of passengers and comprising of more than eight seats in addition to the driver's seat and having a DGVW exceeding 5000kg.

### **Adapted driver's controls**

If a disabled driver's controls or fitments are additional to the standard driver's controls and they do not adversely affect the standard vehicle equipment, they are not testable items. However, if any such equipment is seen to be defective it should be reported to the vehicle presenter. Disabled driver's controls or fitments that replace or affect the standard controls should be tested in the normal way and any defects should be recorded in the normal way.

# Public Service Vehicle Inspection Manual

## List of Inspections

1	Registration Plate	39	Hand Operated Brake Control Valves
2	Not allocated	40	Not allocated
3	Seat Belts and Supplementary Restraint Systems	41	Condition of Chassis
4	Not allocated	42	Electrical Wiring and Equipment
5	Emissions Exhaust	43	Engine and Transmission Mountings
6	Road Wheels and Hubs	44	Oil and Waste Leaks
7	Size and Type of Tyres	45	Fuel Tanks and Systems
8	Condition of Tyres	46	Exhaust and Nuisance
9	Bumper Bars	47	Not allocated
10	Spare Wheel and Carrier	48	Suspension
11	Vehicle to Trailer Coupling	49	Not allocated
12	Not allocated	50	Not allocated
13	Not allocated	51	Not allocated
14	Wings and Wheel Arches	52	Not allocated
15	Not allocated	53	Axles, Stub Axles and Wheel Bearings
16	Passenger Doors, Drivers Doors and Emergency Exits	54	Steering
17	Drivers Accommodation	55	Not allocated
18	Driver's Seat	56	Not allocated
19	Security of Body	57	Transmission
20	Exterior of Body, including Luggage Compartment	58	Additional Braking Devices
21	Interior of Body, Passenger Entrance, Exits Steps and Platforms	59	Brake Systems and Components
22	Mirrors and Indirect Vision Devices	60	Not allocated
23	Glass and View of the Road	61	Not allocated
24	Accessibility Features	62	Reflectors and Rear Markings
25	Windscreen Washers and Wipers	63	Lamps
26	Speedometer/Tachographs	64	Not allocated
27	Horn	65	Not allocated
28	Driving Controls	66	Direction Indicators and Hazard Warning Lamps
29	Not allocated	67	Aim of Headlamps
30	Steering Control	68	Not allocated
31	Not allocated	69	Not allocated
32	Not allocated	70	Not allocated
33	Speed Limiter	71	Service Brake Performance
34	Pressure/Vacuum Warning and Build Up	72	Secondary Brake Performance
35	Not allocated	73	Parking Braker Performance
36	Hand Lever Operating Mechanical Brakes and Electronic Park Brake Controls	74	Other Dangerous Defects and Conditions
37	Service Brake Pedal		
38	Service Brake Operation		

# Public Service Vehicle Inspection Manual

## Standards for Prohibition Issue at Annual Test

This provides a standard for the issue of Prohibition Notices where dangerous deficiencies are observed during statutory tests.

The aim of the policy is to:

- Protect the public and other road users from unsafe vehicles where very dangerous deficiencies have been observed during test.
- Let operators know the rules so that they know and understand the standards for prohibition issue at test.
- Ensure consistency of approach.
- Preserve a balance between providing a flexible, customer focused, testing service and providing the public with protection from loss or injury from vehicles being used on public roads with serious roadworthiness defects.
- Provide information about such occurrences to DVSA Enforcement, and to Traffic Commissioners.

The approach, in principle, is to apply the following:

- Where a dangerous deficiency is marked with an asterisk \* the examiner will be required to assess the severity of the defect in line with the deficiency criteria detailed in the table contained within the following pages, before deciding whether to issue an immediate prohibition.
- Where a dangerous deficiency is **NOT** marked with an asterisk; this will result in the issue of an immediate prohibition.

### **‘S’ Marked Prohibitions:**

Prohibitions issued for defects found at the time of test will be endorsed as ‘S’ mark indicating there is a significant failure of roadworthiness compliance and maintenance, unless in the issuing Examiner’s opinion the defect could not have been foreseen (i.e. a defect arising on the way to the Testing Facility).

### **Note:**

Where an Exemption notice is issued to permit prohibited vehicles to proceed to a place of repair under controlled conditions the conditions of movement must be detailed on the notice. Examiners will issue an Exemption notice only if in their opinion the vehicle can be moved to such a place without risk to public safety.

# Public Service Vehicle Inspection Manual

## Standards for Prohibition Issue at Annual Test

Manual Reference	Deficiency Criteria	Deficiency
IM 3 Seat Belts	Detachment imminent where the applicable drivers and/or passengers' seat will be occupied during the journey following test.	2a (ii)* 6a*
IM 5 Exhaust Emissions	Sufficient to obscure vision or poses an obvious danger to other road users.	3b*
IM 6 Road Wheels and Hubs	Retaining ring is excessively displaced from its seating and total displacement is imminent.  Failure or detachment imminent.	1a*  2d*
IM 7 Size and Type of Tyres	Directional stability is obviously, significantly affected.	1d* 1e* 1f* 2*
IM 8 Condition of Tyres	A tyre so severely damaged that failure of the tyre is likely.  Tyre tread worn below the legal minimum on any tyre fitted to a steered axle and/or 50% or more of the total number of tyres fitted to non-steered axles.	1c*  1h*
IM 10 Spare Wheel & Carrier	Detachment imminent.  Detachment imminent and/or damage to the electrical wiring, other vehicle components or passenger luggage, or injury to occupants is imminent.	1 (iii)*  2 (ii)*
IM11 Vehicle to Trailer Coupling	Detachment imminent.  Imminent danger of injury to passengers or other persons.  Detachment imminent.  Detachment imminent.	1a (ii)*, 1b (ii)* 1c (ii)* 2a (ii)*  2b*  3a (ii)*  4a (ii)*, 4b (ii)* 4c (ii)* 4d (ii)* 5 (ii)*

# Public Service Vehicle Inspection Manual

## Standards for Prohibition Issue at Annual Test

Manual Reference	Deficiency Criteria	Deficiency
IM 17 Driver's Accommodation	Directional control of the vehicle is obviously significantly affected and/or poses imminent danger of injury.	1 (ii)*
IM 18 Driver's Seats	Loss of control of the vehicle imminent.	1 (ii)*
IM 20 Exterior of Body including Luggage Compartments	Detachment imminent and/or imminent danger of injury to other road users or pedestrians.	2b*
IM21 Interior of Body, Passenger Entrances, Exit Steps and Platforms	Imminent danger of injury to the driver and/or passengers or persons.	1b (iii)* 1c* 6*
IM 23 Glass and View of the Road	Imminent danger of injury to the driver and/or passengers or other road users.	2a* 2g*
IM 24 Accessibility Features	Imminent danger of injury to the driver and/or passengers or other road users.	6b (ii)*
IM 30 Steering Control	Imminent danger of injury to any person.	2c*

## Public Service Vehicle Inspection Manual

### Standards for Prohibition Issue at Annual Test

Manual Reference	Deficiency Criteria	Deficiency
<p style="text-align: center;">IM 38 Service Brake Operation</p>	<p>Brake efficiency impaired and poses an immediate danger to road safety.</p>	<p>3 (ii)*</p>
<p style="text-align: center;">IM 41 Condition of Chassis</p>	<p>Loss of control of the vehicle imminent and/or safe carriage of person(s) affected or detachment of component imminent.</p>	<p>1a (ii)* 2a (ii)* 3a (ii)* 3b (ii)*</p>
<p style="text-align: center;">IM 42 Electrical Wiring and Equipment</p>	<p>Wiring touching hot or rotating parts or the ground.</p>	<p>1b (iii)*</p>
<p style="text-align: center;">IM 43 Engine and Transmission Mountings</p>	<p>Engine and/or transmission detachment imminent and poses an immediate danger to road safety.</p>	<p>1a (ii)* 1b (ii)* 1c (ii)*</p>
<p style="text-align: center;">IM 45 Fuel Tanks and System</p>	<p>Detachment imminent.</p>	<p>1b*</p>
<p style="text-align: center;">IM 46 Exhaust Systems and Nuisance</p>	<p>Detachment imminent.</p>	<p>1a (ii)* 3 (ii)*</p>
<p style="text-align: center;">IM 48 Suspension</p>	<p>Steering function impaired and/or the vehicle as presented poses an immediate danger to road safety.</p>	<p>1g*</p>

## Public Service Vehicle Inspection Manual

### Standards for Prohibition Issue at Annual Test

Manual Reference	Deficiency Criteria	Deficiency
<p style="text-align: center;">IM 53 Axles, Stub Axles and Wheel Bearings</p>	<p>A main component so defective that failure is imminent and poses an immediate danger to road safety.</p>	<p style="text-align: center;">1b*</p>
<p style="text-align: center;">IM 54 Steering</p>	<p>Mechanism fractured, cracked, damaged, misaligned, twisted, deformed to the extent that failure is imminent.</p>	<p style="text-align: center;">2i*</p>
<p style="text-align: center;">IM 59 Brake systems and components</p>	<p>A brake back plate insecure or seriously weakened. A brake disc or drum missing, failed or failure imminent.</p>	<p style="text-align: center;">3a(ii) *</p>
<p style="text-align: center;">IM 71 Service Brake Performance</p>	<p>The vehicle as presented, poses an immediate danger to road safety.</p> <p>Efficiency significantly below legal requirements. Before issuing, the examiner must consider whether the vehicle, as presented, poses an immediate danger to road safety.</p>	<p style="text-align: center;">1d (iv)*</p> <p style="text-align: center;">1d (v)*</p>
<p style="text-align: center;">IM 72 Secondary Brake Performance</p>	<p>The vehicle as presented, poses an immediate danger to road safety.</p> <p>Efficiency significantly below legal requirements. Before issuing, the examiner must consider whether the vehicle, as presented, poses an immediate danger to road safety.</p>	<p style="text-align: center;">1b (ii)*</p> <p style="text-align: center;">1c*</p>
<p style="text-align: center;">IM 73 Parking Brake Performance</p>	<p>Before issuing the examiner must consider whether the vehicle as presented, poses an immediate danger to road safety.</p> <p>Efficiency significantly below legal requirements. Before issuing, the examiner must consider whether the vehicle, as presented, poses an immediate danger to road safety.</p>	<p style="text-align: center;">1a (ii)*</p> <p style="text-align: center;">1b*</p>

# Public Service Vehicle Inspection Manual

## 01 Registration Plate

### Application

This inspection applies to all registered motorised vehicles.

### Procedure and Standards

A registration plate should be easily legible to a person standing approximately 20m from the front/rear of the vehicle. Where a registration plate is obviously obscured by objects such as tow bars this will be a deficiency under 2b.

The registration plate must be checked for presence and security at the front and rear of the vehicle. You do not have to physically measure the characters or their spacing and you should only reject them if they are obviously incorrect

Registration plates must not:

- be obscured, excessively damaged, deteriorated or delaminated.
- have background overprinting.
- have any feature or fixing that has the effect of changing the appearance or legibility of any of the characters including the use of tints or films.
- have a honeycomb or similar effect background on vehicles first registered on or after 1 September 2001 - back lit registration plates may have a honeycomb type construction which should not be confused with a honeycomb effect background.

You should pay particular attention to the position of any fixing screws or bolts as well as any delamination of the number plate as this can prevent identification of the vehicle by automatic number plate recognition (ANPR) cameras which 'see' any non-reflective material as being black.

Registration plates may:

- have an optional non-reflective border displayed within the margin which must be:
  - no wider than 6mm and not within 5mm of the characters on vehicles first used before 1 September 2021.
  - no wider than 5mm and not within 10mm of the characters on vehicles first used on or after 1 September 2021.
- display white, grey or silver characters on a black background - only on vehicles manufactured before 1 January 1980.

# Public Service Vehicle Inspection Manual

## 01 Registration Plate

The registration mark must be checked for presence and legibility.

A registration mark with characters which are obviously incorrectly spaced, misformed or uses misplaced fixing bolts to alter the registration mark appearance, will be deemed to be not in accordance with the requirements

Registration plates characters:

- may contain grey, possibly to achieve a 3D or highlighting effect (only on vehicles first used before 1 September 2021)
- may be raised or 3D
- must be the correct size, stroke width and spacing.
- must not be italic, sloping or formed using broken or multiple strokes.
- must be laid out in the correct format for the age of vehicle.
- must be formed using the prescribed font or be substantially similar to the prescribed font - as shown below.

You do not have to physically measure the characters or their spacing and you should only reject them if they are **obviously incorrect**.

**I234567890**  
**ABCDEFGHIJKLMN OPQRSTUVWXYZ**

Registration plates fitted to vehicles manufactured on or after 1 January 1980 must:

- have black characters on a white background when fitted to the front
- have black characters on a yellow background when fitted to the rear
- be fitted vertically, or as close to vertical as is reasonably practicable

Registration plates fitted to vehicles first registered on or after 1 September 2021:

- all characters must be a single shade of black
- may be raised, but the entire surface of the characters, including the sides, must be a single shade of black
- may have an integral raised or depressed border around the number plate periphery, not more than 5mm wide and 2mm high

# Public Service Vehicle Inspection Manual

## 01 Registration Plate

Registration plates may be in a single- or two-line formats. Additionally, a three-line format is permitted on vehicles first used before 1 September 2001.

Any optional non-reflective border must be at least 5mm from the characters

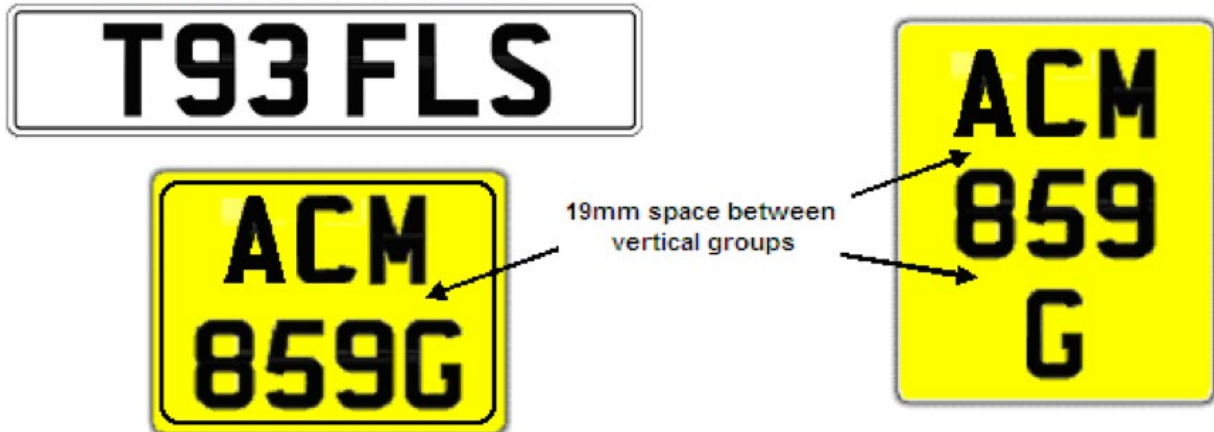

Registration plates must meet the dimensional requirements shown in the example below. However, the space between a number '1' or a letter 'L' and another character is permitted to be proportionately greater. Vehicles with non-date related plates, such as those issued before 1963 and Northern Ireland plates must still meet the separation requirement between groups of characters where relevant.



Vehicles registered before 1 September 2001 can have larger plates fitted with characters 89mm high and other relevant dimensions that are subsequently larger.

Registration plates may display UK national flags or lettering on the left-hand side and they may also show a green flash here to indicate that the vehicle is electric.

# Public Service Vehicle Inspection Manual

## 01 Registration Plate

Deficiency	Deficiency Category
1 <b>A registration plate:</b>  a.        missing.  b.        insecure.  c.        not in accordance with the requirements.	Major  Major  Major
2 <b>A registration mark:</b>  a.        missing.  b.        illegible.  c.        not in accordance with the requirements.	Major  Major  Major

03 Seat Belts & Supplementary Restraint Systems

**Application**

This inspection applies to all buses which have seat belts fitted.

The inspection of Supplementary Restraint Systems (SRS) applies to airbags, seat belt pretensioners and seat belt load limiters when fitted as standard.

**Procedure and Standards**

Certain buses require seat belts regardless of their use (Obligatory belts). These are shown in the tables to the rear of the application section, along with the seat belts which are required. These must be checked to ensure that seat belts are fitted to the seats on which they were determined to be needed at the time of certification.

Seat belts may be fitted to all types of minibuses, buses and coaches, both single and double decked, and may be in addition to those required in the tables at the end of this section. It will not be necessary to carry out the installation check unless extra belts have been fitted since the last test, but the condition check must be carried out on all belts and fittings on the vehicle.

First used	Inspection required
Before 1 October 2001	Condition check and standard installation check where seat belts or extra seat belts added since last test.
From 1 October 2001	Condition check Installation checks are not required on vehicles that have not been modified since certification. If the number of seats fitted with seatbelts is greater than the number shown on the technical record for the vehicle see the section below on the Enhanced Installation Check.

**Condition inspection of all seat belts fitted**

As far as it is practicable without dismantling, check the condition of the vehicle structure around the seat belt anchorage points (i.e. within 30cm of the anchorage). Where a seat belt is mounted to a seat frame this will apply to all seat mounting points. The floor-mounted anchorage points might need to be inspected from underneath the vehicle.

**For seats with integral seat belts**, it might not be possible to examine the fixing of the seat belt to the seat.

When assessing cuts or damage:

- Lateral cuts or damage on either edge of the webbing in excess of 2mm are likely to reduce the webbing strength significantly and will be deemed a deficiency.
- Lateral cuts or damage away from the webbing edges have a lesser effect on the tensile strength of a belt, only cuts or damage obviously in excess of 4mm shall be considered a deficiency.
- Vertical cuts or damage travelling along the belt length will have a lesser effect on the tensile strength than lateral cuts across the belt as there is less of a tendency to tear. A deficiency here should only be considered where there is substantial damage to such an extent that the belt strength is obviously seriously reduced.

**Some types of retracting belt** might need manual help before they retract.

## 03 Seat Belts & Supplementary Restraint Systems

**Operate the release mechanism while pulling on the belt** to check that the mechanism releases when required.

**Where a belt is fitted with no corresponding seat** or if there is a buckle/stalk but no corresponding belt, it is NOT to be considered a seat belt for the purpose of this inspection.

The SRS malfunction indicator lamp (MIL) may display a symbol similar to that below, one depicting a person wearing a seat belt or alternatively the letters 'SRS'.



**A passenger air bag which has been switched off** is not deficiency.

**Air bags are not a mandatory fitment**, the deficiency for air bag missing must only be used where it is obvious the vehicle had an air bag fitted and it is now missing.

### Standard Installation Check

All belts should be checked for installation, operation and wear, except for the following categories which shall be checked for operation and wear only:

1. Seat belts provided for rear or side facing seats.
2. Disabled person's belts which are permanently attached to the vehicle.
3. Child restraints which are permanently attached to the vehicle.
4. Obligatory seat belts as specified at the rear of the application section.

**No check is required for disabled person's belts or child restraints** which are not permanently attached to the vehicle.

It will be necessary to ask the operator to remove seat cushions and to open any access flap or luggage locker door, which was designed to be capable of being readily opened, to allow as much as possible of the seat belt installation to be seen. Some parts of the installation may only be visible with the vehicle on a pit or hoist.

Where a vehicle is fitted with a type approved belt installation it will not be necessary to carry out an installation check. These belts are at present only likely to be fitted to buses with factory installed belts. Details of the vehicles which are fitted with type approved seat belts are shown at the end of this section.

The seats and seat frames should be checked for security and damage. The seat belt anchorages should be checked for security.

If an operator has been provided with documentary evidence to show that a seat belt installation complies with type approval standards (but has not been fully type approved) or that is traceable to an installation tested and shown to meet the requirements of ECE Regulation 14 or Community Directive 76/115 it should be produced at the time of test. It should show registration number or chassis number of the vehicle and the name and address of the installer. It should also show the test number, date and location of the test of the installation (Original certificates are required, photocopies are not acceptable). Presentation of the certificate would not replace the need for the examination to be conducted but it may support the quality of the installation and help resolve differences over the acceptability of the installation, e.g. reinforcement plates used.

Diagram 1 at the end of the section shows typical methods of attaching seat belts.

**Where the word close is used** it should generally be regarded as 50mm or less.

**03 Seat Belts & Supplementary Restraint Systems**

- A. Check that on all belts the buckle operates correctly and the seat belt adjusts satisfactorily. Subsequent cutting or reworking of the webbing will be a deficiency. It is acceptable for the free end of looped belts or static belts to be reworked to the extent of folding and stitching the webbing so that it cannot pass back through the buckle to prevent the buckle from being dismantled. Any knots in the belt webbing are unacceptable.
- B. Seat squabs should be removed, to aid the inspection of the condition of the belt and mountings. They must be replaced before the end of the test to allow inspection of the complete belt installation.
- C. Check for the presence of any sharp edges which the belt could rub on or pull across during use.
- D. Where seat belts, other than looped belts, are anchored to the seat frame or the vehicle floor they must be secured with mounting bolts in accordance with the following:

**Minimum Acceptable Size and Grade of Bolts for Seat Belt Anchorages**

Type of anchorage	Minibus	Coach or large bus
Single anchorage	M10 Standard material	M8 high tensile steel M10 standard material
Double anchorage	7/16" Standard material M10 High tensile steel	7/16" Standard material M10 High tensile steel

**Bolt head marks:**

Standard Material = P, 4.6 or SAE equivalent

High Tensile Steel = S, 8.8, or SAE equivalent

No Markings = Standard Material

If the examiner cannot determine the grade of bolt it must be assumed to be of Standard Grade.

It is paramount that the appropriate sized bolt is used in the seat belt anchorage, i.e. an 8mm bolt should not be used in an 11.5mm diameter hole. The only exception to this is where a "stepped washer" or collar is used to eliminate the excessive clearance and a suitable washer is fitted between the bolt head and the anchorage to prevent the bolt pulling through. The use of smaller bolts, self tapping screws or wood screws is not acceptable.

- E. It is not acceptable to drill tubular seat frames to allow belts to be bolted to the frame except in cases where a manufacturer has approved the installation and the operator presents a certificate issued by the manufacturer or his agent declaring that the installation is satisfactory.
- F. Clamp type brackets are acceptable provided that they are properly secured (see Diagram 2).

03 Seat Belts & Supplementary Restraint Systems

- G. On seats constructed with a wooden frame it is unacceptable to mount the belts either directly to the frame or to a metal base which is attached to the frame only by wood screws. Unless there are additional reinforcement brackets fitted that provide a direct load path to the seat leg and side mounting the installation would be rejected. This reinforcement could take the form of steel angle sections or plates, alternative materials may be used provided that they are of comparable strength (see Diagrams 3 & 4 for details of a typical installation).
- H. Where seat belts are attached to thin sheet metal seat frames the bolts anchoring the belt must be of the minimum dimensions shown in paragraph D and must be adequately supported by the use of load spreading washers between the frame and the nut. Typically this would be 25 mm in diameter and 2 mm thick. If two belts are attached at the same point with a single bolt then a larger reinforcement plate 35mm diameter x 3mm thick (or a rectangular plate of minimum dimensions 21 x 46 x 3 mm) must be used. The sizes quoted are for steel reinforcement plates, alternative materials may be used but must provide comparable strength.
- I. Where seat belts are fitted to the rear seats of a vehicle check the anchorage to ensure that it is not anchored solely to the thin metal sheet which separates the boot area from the passenger compartment. It is essential that seat belt anchorages are secured to a strong cross member connected to the structural members of the vehicle. The connection should be to such a standard that there is confidence that it will be able to transfer the seat belt loads into the structure of the vehicle. This may involve the fabrication of an additional framework at the rear of the vehicle. An example of typical reinforcement of this area would be by the use of additional square section tubing 40 x 40 x 3mm, or angle plate 50 x 50 x 4 mm across the full width of the vehicle. The sizes quoted are for steel reinforcement, alternative materials may be used but must provide comparable strength. A full width reinforcement that is only attached to the thin metal sheet is unacceptable and would be a deficiency.
- J. Three point belts will only be accepted under the following circumstances:  
If the seat utilises tubular frames or tubular “H” pattern legs:
- The seats have been reinforced as detailed in Paragraph K or
  - A purpose built structure to which belts are attached is fitted to the vehicle, an example is shown in diagram 5. Alternatively the belts may be attached to solid bodywork
- or
- If purpose made seats designed with integral three point belts as standard have been fitted.
- K. Where seats that are permanently mounted in the vehicle have been fitted with lap belts or 3 point belts integral to the seat, then, if the seat utilises tubular frames or tubular “H” pattern legs it must be reinforced. This will include welding metal buttresses, of similar thickness material as the foot, between the foot and the leg (see diagram 6). Also the welding of a diagonal brace, either in compression or tension, between the foot and the seat base attachment of each leg. Alternatively documentary evidence of compliance with Directive 76/115 or ECE Regulation 14 can be presented.

03 Seat Belts & Supplementary Restraint Systems

On quick release seats where the feet are mounted directly to tracking by a coupling it may not be practical to weld a buttress to the leg or a diagonal brace to the foot due to the presence of the coupling (see diagram 7).

The coupling would prevent any reinforcement being placed in an effective position; also the coupling could be damaged if welding occurred close to it. On this type of installation the belts can be attached directly to the tracking with quick release mounts or the legs should be modified to use an alternative method of attachment to the tracking.

On seats where the feet are mounted to a metal bar or tube which is then connected to tracking by a quick release coupling, then the seat has to be reinforced with buttresses and diagonal brace as detailed above.

On vehicles with floor mounted seat belts where the belt is anchored close to the seat mounting bolt then the rear foot of each leg must be buttressed to the leg.

- L. If lap belts are fitted and there is the possibility of passengers hitting their heads on any harsh object such as a grab rail or seat stanchion, padding or other suitable protection must be provided on these objects. The protection does not need to cover the full length of a seat grab rail but should cover a length of at least 300mm directly in front of each passenger. Padding must be compressible and of a depth of at least 50 mm, measured to the surface of the bar and not compress more than 25mm under reasonable thumb pressure, or 25mm thick and not compress more than 5mm. Ordinary seat foam or pipe lagging foam is unlikely to be of sufficient density for this purpose.
- M. Lower anchorages should be at least 320 mm apart. This need not be the distance between the anchorage points of the belt but it can be between two structural parts of the seat that the belt is routed round. If the measurement is between mounting bolts it should be measured between bolt centres. Check that the belt will not raise or significantly compress the seat cushion when subjected to a load. There will always be a small amount of compression which is acceptable.
- N. Where belts are attached directly to a metal floor a load spreading washer must be used between the nut and the floor. The bolts must be at least the sizes specified in paragraph D. Typically this would be 25 mm in diameter and 2 mm thick. If two belts are attached at the same point with a single bolt then a larger reinforcement plate of minimum dimensions 35mm diameter x 3mm thick (or a rectangular plate of minimum dimensions 21 x 46 x 3 mm) must be used. The sizes quoted are for a steel reinforcement plates, alternative materials may be used but must provide comparable strength. Reinforcement plates should follow, as far as practicable, any contours in the floor to which they are attached.
- O. Where a belt is attached directly to a wooden floor each anchorage must be reinforced with a plate of minimum dimensions 35mm diameter x 3mm thick (or a rectangular plate of minimum dimensions 21 x 46 x 3 mm). If two belts are attached at the same point with a single bolt then the reinforcement plate must have minimum dimensions of 92mm diameter x 3mm thick (or a rectangular plate of minimum dimensions 65x 100 x 3 mm). If two belts are attached in close proximity to each other, then a single reinforcement plate of minimum dimensions of 92mm diameter x 3mm thick (or a

03 Seat Belts & Supplementary Restraint Systems

rectangular plate of minimum dimensions 46x 46 x 3 mm). The sizes quoted are for a steel reinforcement plates, alternative materials may be used but must provide comparable strength. Reinforcement plates should follow, as far as practicable, any contours in the floor to which they are attached.

- P. Where mounting rails designed for the adjustment of seat pitch are fitted and utilise an angled claw type clamp (see Diagram 8) with a clamping face of less than 15mm wide it is not acceptable for a seat on which a belt is mounted to be merely clamped to the rail. The clamp to the rear foot of each leg must be modified by fitting a bolt which passes through the claw fitting, the rail, floor and a suitable structural member (as in most vehicles). The bolts must have appropriately sized load spreading washers fitted beneath the bolt head and underneath the retaining nut. A single bolt should be not less than 8 mm (5/16") diameter. Any alternative to this is only acceptable if documentary evidence is provided.
- Q. Parallel type claw fittings, for a seat on which a belt is mounted, will be considered satisfactory provided that the securing bolts are fully tightened. (see Diagram 9).
- R. If a seat, on which a belt is mounted, is bolted to a flat rail the bolts must pass through the leg, rail, floor and a suitable structural member.
- S. It is acceptable for seats to be attached to a purpose built tracking (e.g. keyhole, "T" slot) designed for securing seats and wheel chairs, providing the tracking are securely attached to the vehicle structure with bolts or fasteners in all the retaining holes or marks provided by the manufacturers.
- T. It is unacceptable to fit seats, with seat belts, directly to unsupported wooden floors unless additional reinforcement is provided. This will involve the fitting of steel reinforcement plates of minimum dimensions 92mm diameter x 3mm thick (or a rectangular plate of minimum dimensions 65x 100 x 3 mm), between the underside of the floor and the securing nut below the floor of the rear leg and between the leg and the topside of the floor of the front leg. If the area of the foot of the front leg is greater than 65 x 100 mm, then the front reinforcement plate is unnecessary.
- U. A "looped" type seat belt fitting is acceptable provided it is not free to float along any part of the seat structure. Any free movement in excess of 25mm is a deficiency.
- V. The upper anchorage point should be at least 475mm above the height of an uncompressed seat cushion. This dimension is to be measured parallel to the backrest. The upper anchorage point should be a minimum of 110mm from the centre line of the seat back to the side of the seat.
- W. A lap belt or the lap section of a 3 point belt must be positioned to lie across the wearer's pelvis and not the stomach. This is to reduce the risk of abdominal injury and to prevent "submarining". In practice this may result in the belt lying across the top quarter of the thigh.
- X. Seat belt components should not be fitted to seats in such a way that they significantly intrude into the gangway space and are likely to cause injury to passengers either by tripping or by hitting the component.

**There may be occasions when carrying out the condition check**, on a vehicle which had an installation check on a previous test, that obvious defects are found in an installation item. This will be a deficiency.

**03 Seat Belts & Supplementary Restraint Systems**

**Enhanced Installation Check**

Vehicles certified from 1 November 2002 have either had evidence that they comply with directive requirements regarding anchorages, including the results of a pull test or have had an Enhanced Visual Inspection. In addition some altered vehicles which have had seats and or seat belts added will require this type of installation check rather than the original installation check specified on pages 2 to 6 of the procedure and standards section. Only certifying officers will carry out the enhanced inspection or interpret the results of pull tests. Details of which vehicle requires which type of installation inspection following the fitting of additional seats and/or seat belts are in the table on the following page.

Where an alteration involves the installation of seat belts, or an increase in the number of seat belts fitted, care must be taken to ascertain the relevant dates. This is vital in determining the action to take.

First Used	Installation Check
From 1 October 2001 with additional obligatory seat belts fitted	Check whether any additional seats have been fitted since the vehicle was certified. This can be done by checking the technical record or the operator's certificate of initial fitness (PSV 418) or carrying capacity authorisation (PSV445).
	If the vehicle has had additional seats fitted and there is no evidence that the seat belt installation has been checked the vehicle should be refused a test certificate using the deficiency 11(w).
	Advise operator (using form VTP57) to submit a notifiable alteration (VTP5) and to arrange to have the installation checked by a certifying officer.
	The certifying officer, following a satisfactory inspection, will issue a revised carrying capacity authorisation (PSV445). When the operator represents the vehicle for retest check the new carrying capacity authorisation to ensure the number of seats corresponds with the number of seats on the vehicle.
From 1 October 2001 Check whether extra seats and/or seat belts have been fitted	<p>Check whether extra seats and/or seat belts have been fitted since the last annual test. This can be done by checking the technical record or the operators certificate of initial fitness (PSV 418) or carrying capacity authorisation (PSV445) or the seat belt inspection form SB1 or SB2.</p> <p>The SB1 form is used to certify that a seat belt installation check was carried out using the criteria in this manual, the SB2 form is used to certify that a seat belt anchorage check was carried out using documentary evidence of a pull test or the enhanced visual installation check. If fitted before the 01st November 2002 carry out standard installation check.</p> <p>If fitted after 1 November 2002 it will be necessary to submit a VTP5 notifiable alteration form (inform the presenter using form VTP57). The operator/presenter will have to provide evidence to a Certifying Officer that the installation has been subjected to a pull test or will have to have a Certifying Officer carry out a satisfactory visual check to the enhanced requirements. Following a satisfactory check a form SB2 will be issued showing the number of seats fitted with belts.</p> <p>A test certificate should be refused if there is no SB2 form or other evidence that the seat belt anchorages have been checked under deficiency 11(w).</p>

03 Seat Belts & Supplementary Restraint Systems

**Seat Belt Installation Check - Exempt Vehicles**

**Ford Transits** with type approved seat belt installations can be identified as follows:

- 12, 14, 15, 16 and 17 seat (including the driver) Transits manufactured after 1 October 1991 where the fourth character of the VIN Number is "E".
- 17 seat (including the driver) Transits where there is a six figure code EJA \*CL or EJJ \*CL marked in the box on the top right hand of the manufacturer's plate (in the type code box). In the code the fourth digit marked \* may be any character.

**LDV 200 & 400 series** models with type approved seat belt installations can be identified as follows:

- chassis number from 933478 onwards and the seventh character of the VIN number is "S".

**LDV Pilot and Convoy** models with type approved seat belt installations can be identified as follows:

- chassis number from 000001 onwards and the seventh character of the VIN number is "S", "X", or "Z".

**LDV Maxus** models with type approved seat belt installations can be identified as follows:

- the 7<sup>th</sup> digit of the VIN number should be either a '6' or 'X'

**Mellor bodied Renault Masters** which have been issued with a PSV Certificate of Conformity (PSV 408) in place of a Certificate of Initial Fitness. This can be checked on the vehicle's technical record.

**Berkhof bodied coaches** – Excellence 3000, Axial 30, 50 and 70 and Radial model coaches with body numbers from 2852 onwards.

Information on other makes will be circulated when it becomes available.

**Important note: To be exempt from the check vehicles must have been fitted with the seat belt installation by the vehicle manufacturer when new. If you are aware that a vehicle with a chassis number shown above has had any seats / seat belts fitted by any other installer, e.g. where it has been adapted to carry wheelchairs and has removable seats on tracking, it will not be exempt and will require an installation check.**

**03 Seat Belts & Supplementary Restraint Systems**

**Obligatory belts**

Minibuses with 9-12 passenger seats and with unladen weight not exceeding 2540kg first used before 1 October 1988:

Date of first use	Seat position	Type of belt
From 1 January 1965 to 31 March 1982	Driver's and any specified passenger's seat	Three point adult belt or body restraining belt
From 1 April 1982 to 30 September 1988	Driver's and any specified passenger's seat	Three point adult belt

Minibuses (not exceeding 3500 kg design gross weight) and coaches first used from 1 October 1988 until 30 September 2001:

Seat position	Minibus not exceeding 3500kg design gross weight.	Coach
Driver's	Three point adult belt. Must be able to be locked and released by a single action. (Exempt for disabled drivers.)	Three point adult belt or lap belt designed for an adult or a disabled persons belt. Must be able to be locked and released by a single action. (Exempt for disabled drivers.)
Specified Passenger's	Three point adult belt. If alongside the driver must lock and release with a single action.	
Any other foremost forward facing front	Three point adult belt or lap belt designed for an adult.	Three point adult belt or lap belt designed for an adult or a disabled persons belt
Other forward facing (not protected by high backed seats) and crew seats		Three point adult belt or lap belt designed for an adult or a disabled persons belt

03 Seat Belts & Supplementary Restraint Systems

Buses, coaches and minibuses first used from 1 October 2001 which are not authorised to carry standing passengers:

Seat position	Not exceeding 3500kg design gross weight	Exceeding 3500kg design gross weight
All forward and rearward facing seats including the driver's seat	<p>An inertia reel 3 point belt or                      A retractable lap belt (on rearward facing seats only) or                      A disabled person's belt or                      A child restraint</p> <p>Seat belts for the driver and specified passenger alongside the driver must be able to be locked and released by a single action.                      (Exemption for a disabled person's belt)</p>	<p>An inertia reel 3 point belt or                      A retractable lap belt or</p> <p>A disabled person's belt or                      A child restraint</p> <p><u>Buses</u>                      Seat belts for the driver and specified passenger alongside the driver must be able to be locked and released by a single action.                      (Exemption for a disabled person's belt)</p> <p><u>Coaches</u>                      Driver's seat belt must be able to be locked and released with a single action                      (Exemption for a disabled person's belt)</p>
On vehicles constructed for the secure transport of prisoners the driver's seat and any seat for front seat passengers	<p>An inertia reel 3 point belt</p> <p>Seat belts for the driver and specified passenger alongside the driver must be able to be locked and released by a single action                      (Exemption for a disabled person's belt)</p>	<p>An inertia reel 3 point belt</p> <p>Seat belts for the driver and specified passenger alongside the driver must be able to be locked and released by a single action                      (Exemption for a disabled person's belt)</p>

**A harness belt** may be used as an alternative to a three point or lap belt. The requirement for a buckle to lock with a single action does not apply to harness belts.

03 Seat Belts & Supplementary Restraint Systems

Diagram 1 - Typical Methods of attaching seat belts

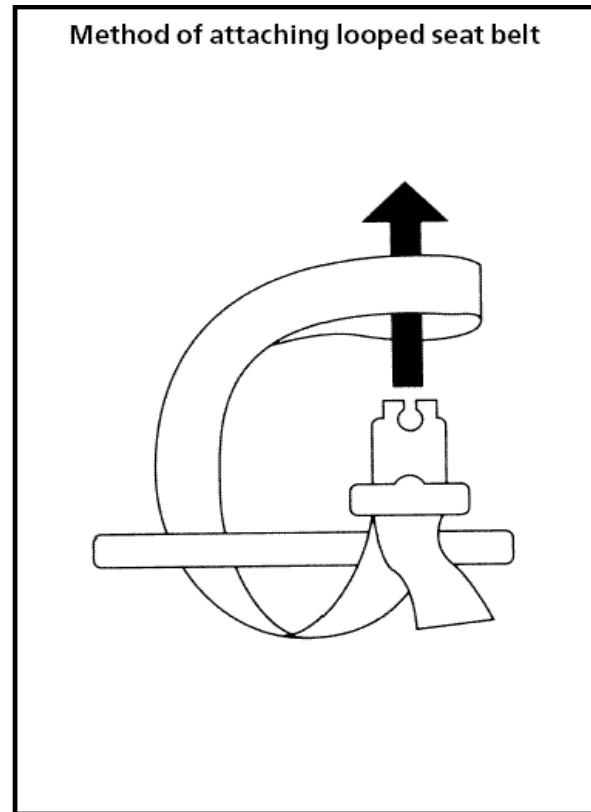
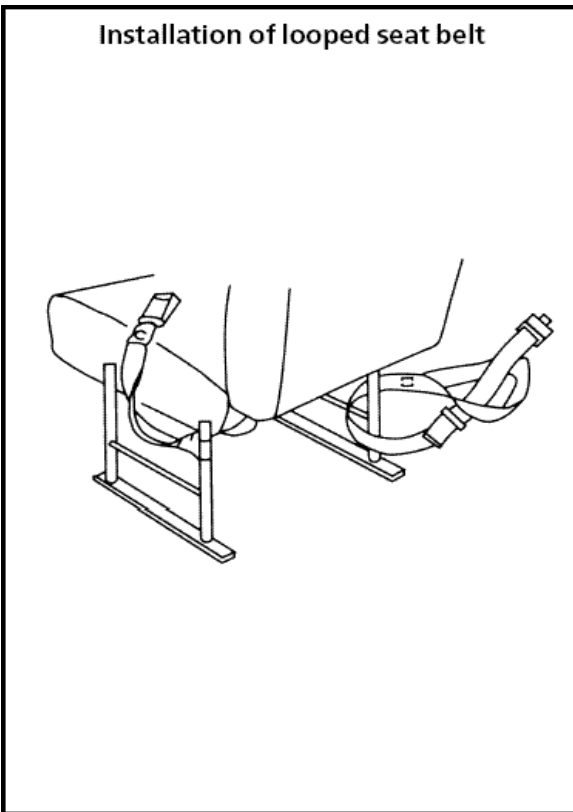
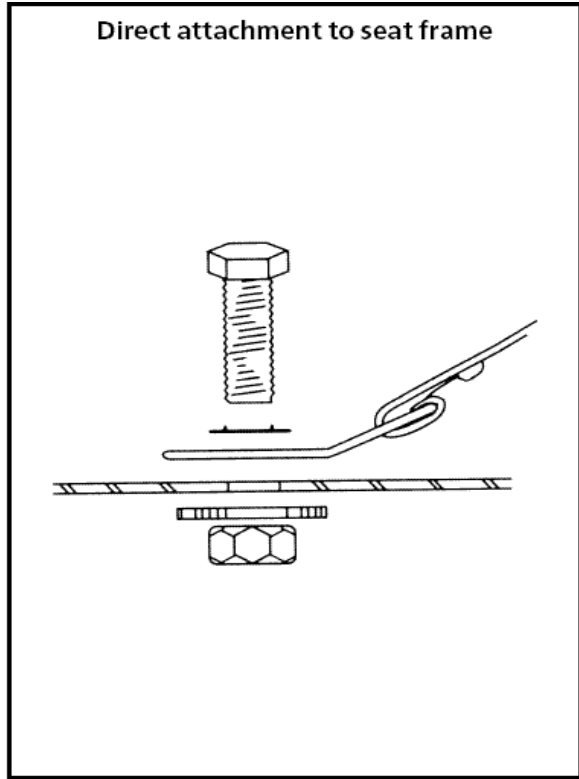
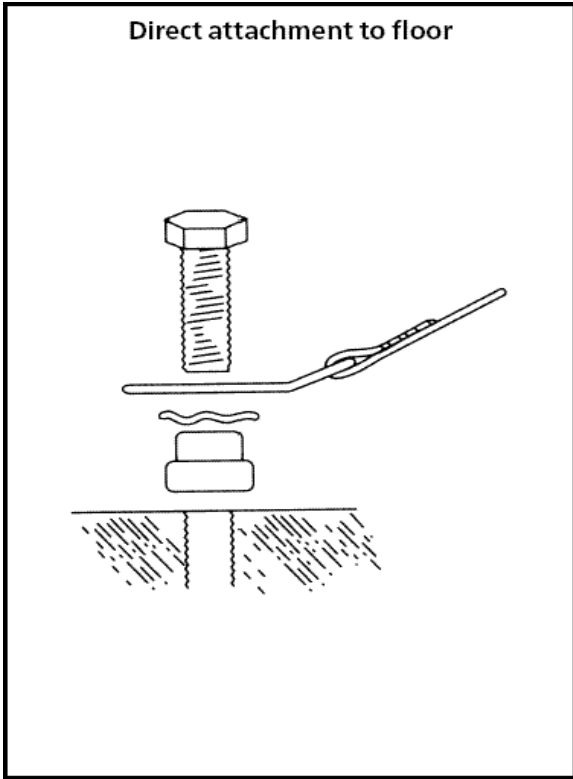

03 Seat Belts & Supplementary Restraint Systems

Diagram 2 – Example of a typical clamp bracket

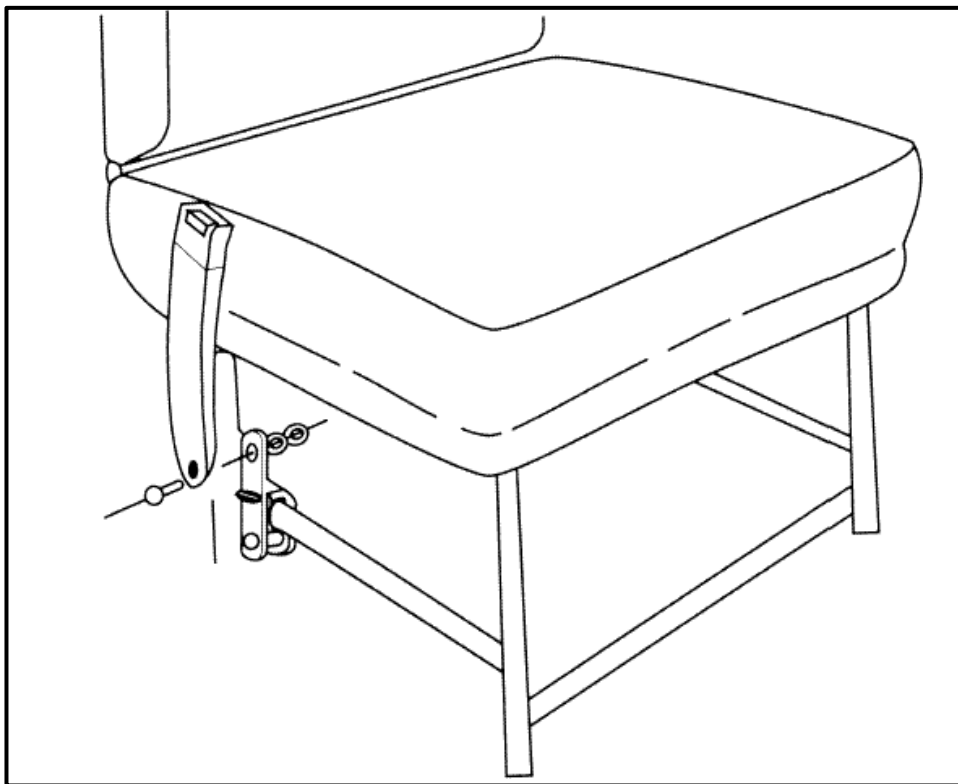
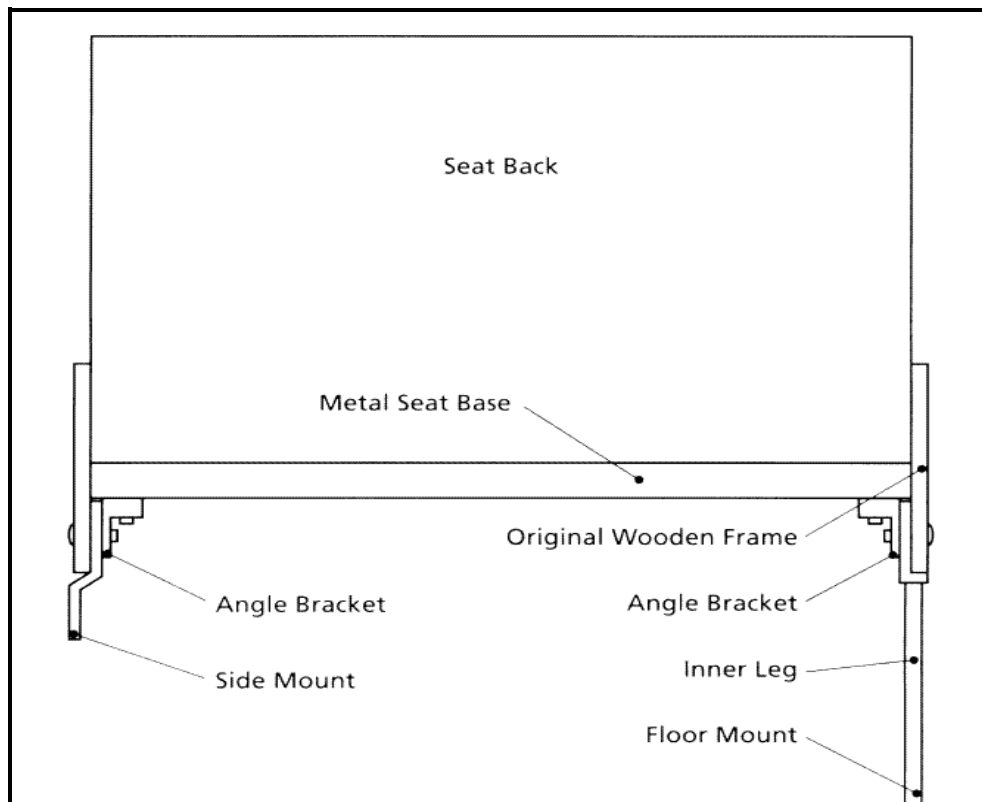

Diagram 3 – Wooden frame with a metal base (rear view)



03 Seat Belts & Supplementary Restraint Systems

Diagram 4 - Wooden framed seats with a metal base  
(enlargement of reinforcement)

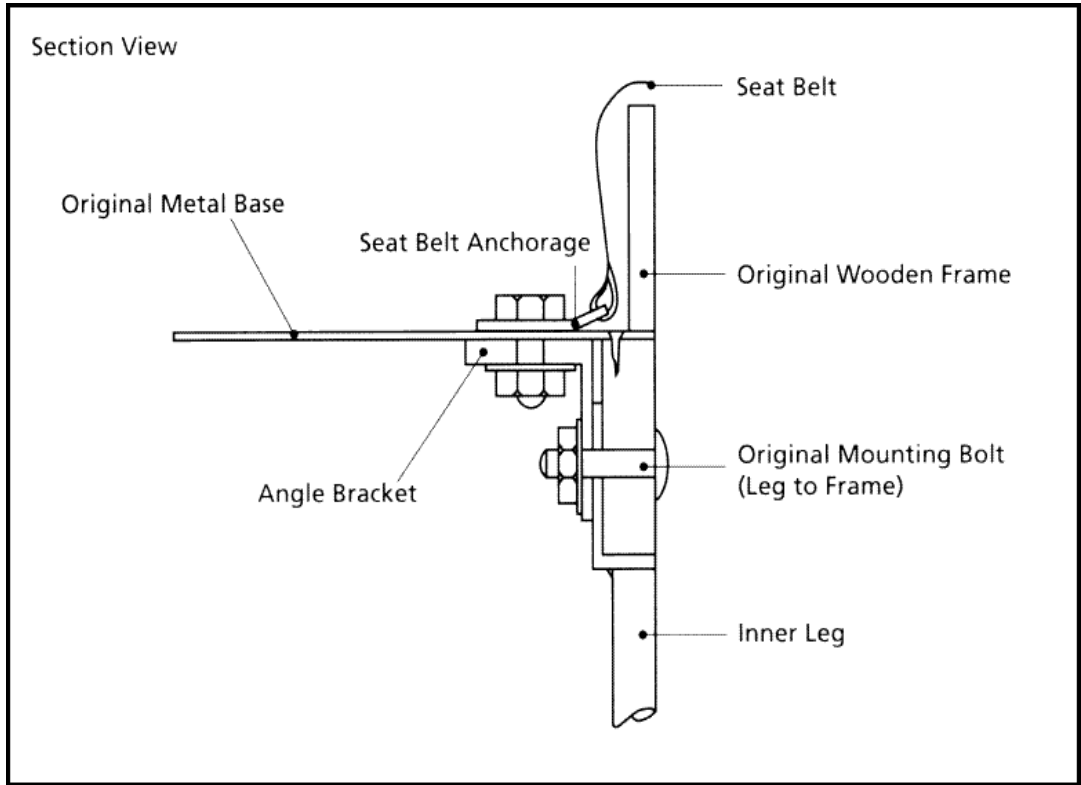
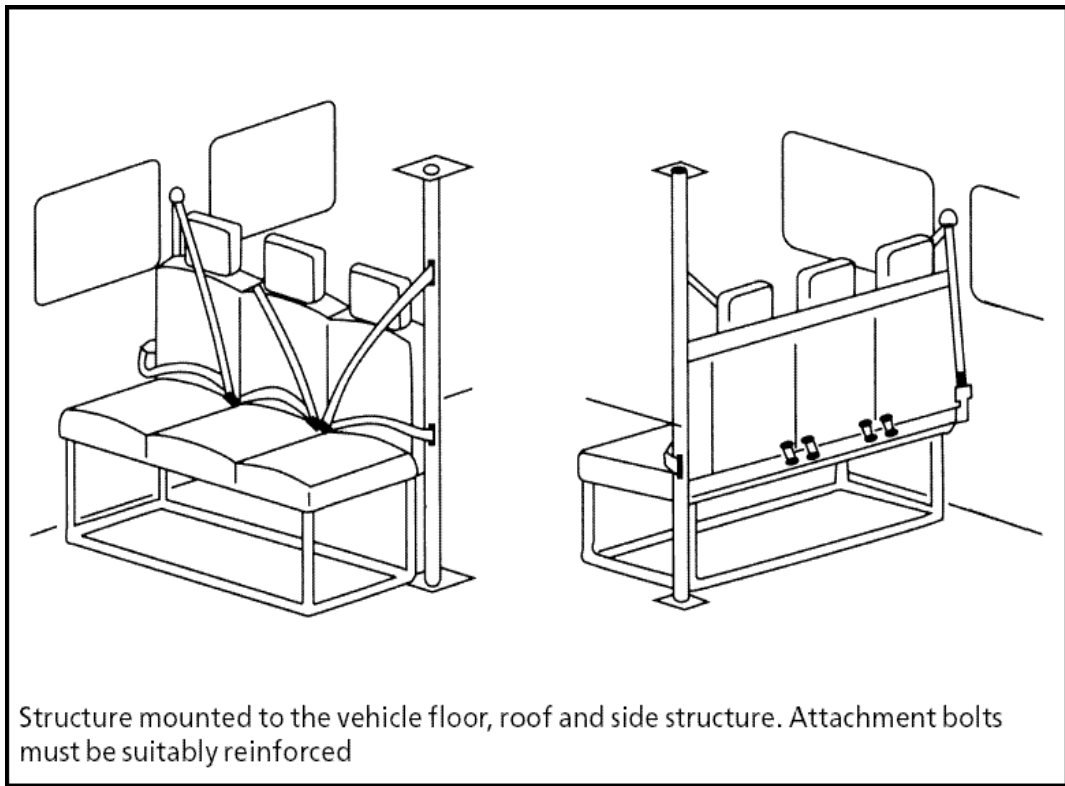
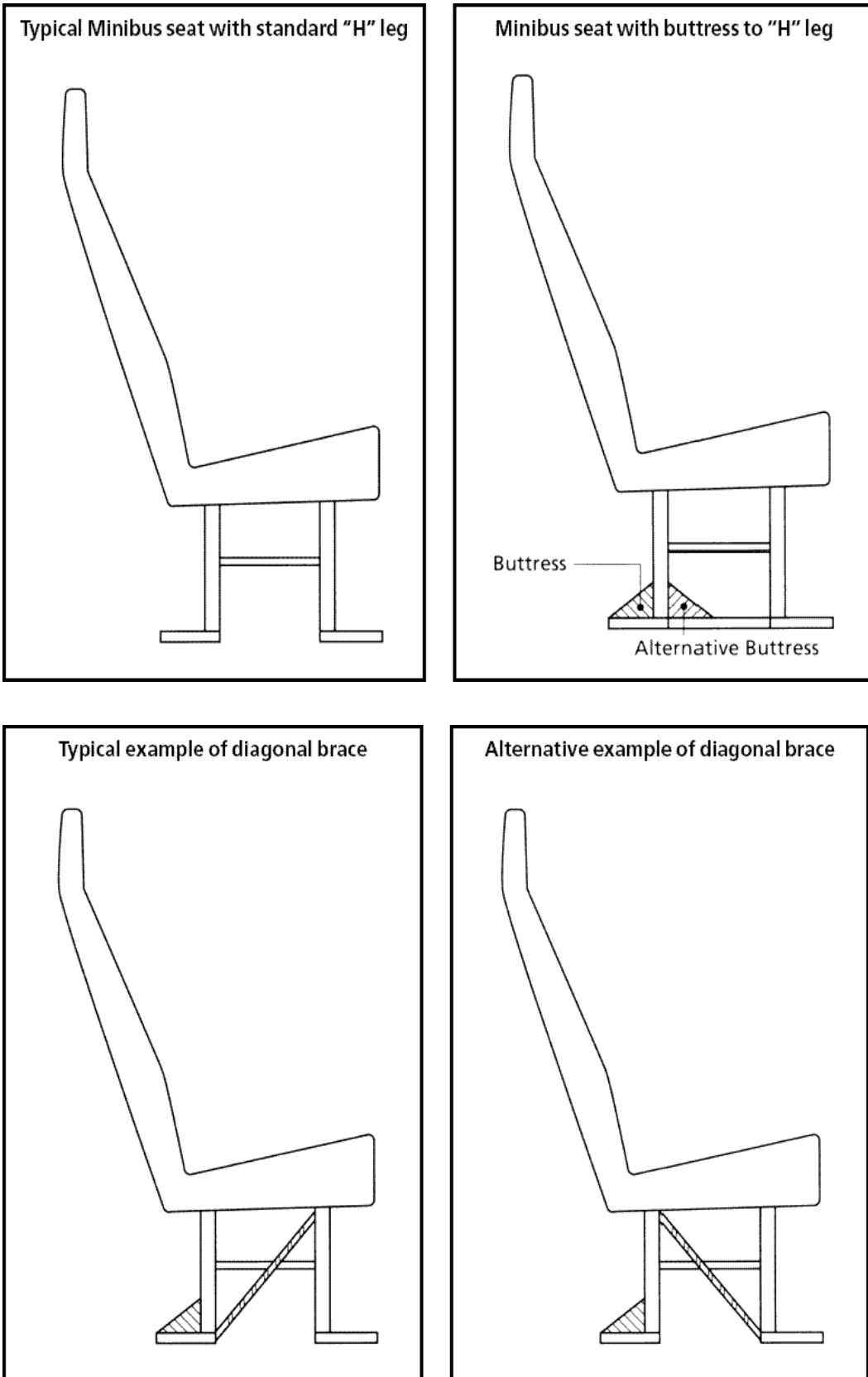

Diagram 5 - Example of additional structure for support of upper anchorage points



03 Seat Belts & Supplementary Restraint Systems

Diagram 6 – “H” leg examples



03 Seat Belts & Supplementary Restraint Systems

Diagram 7 – Quick release seat examples

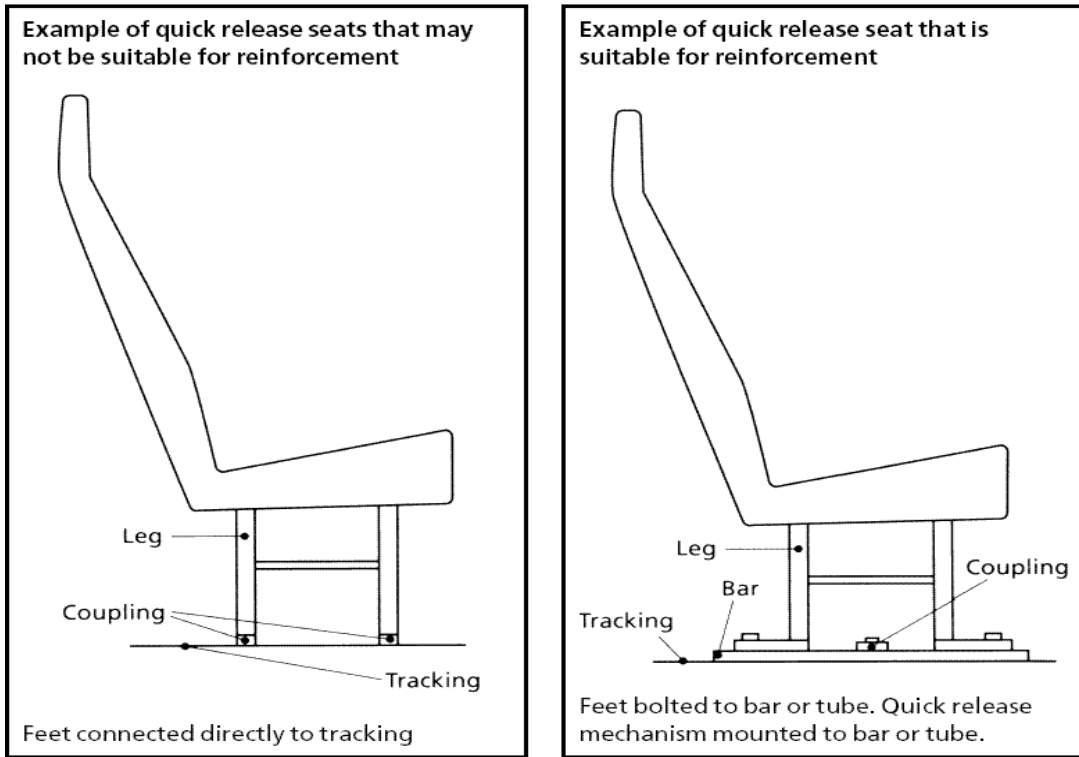
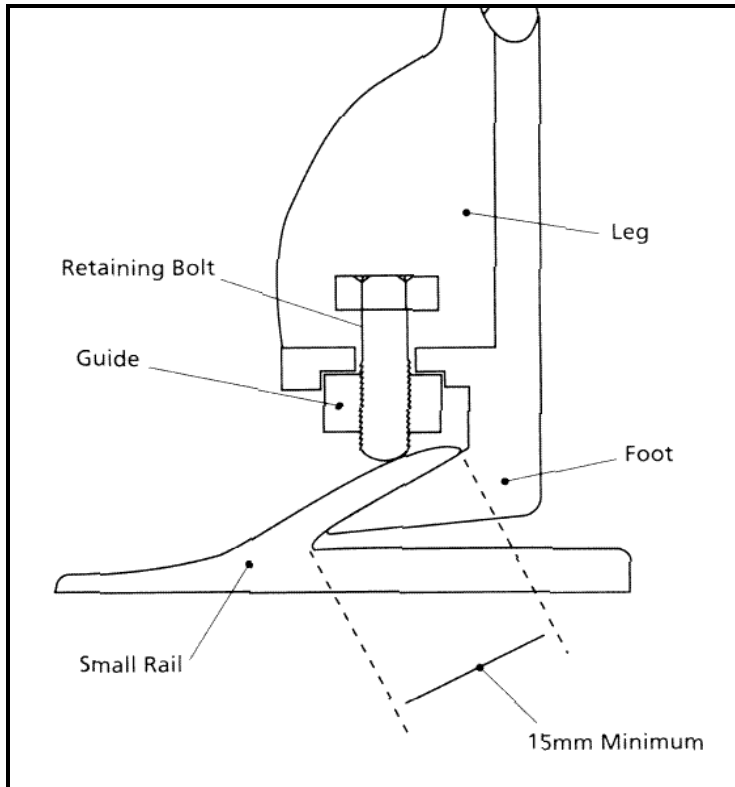
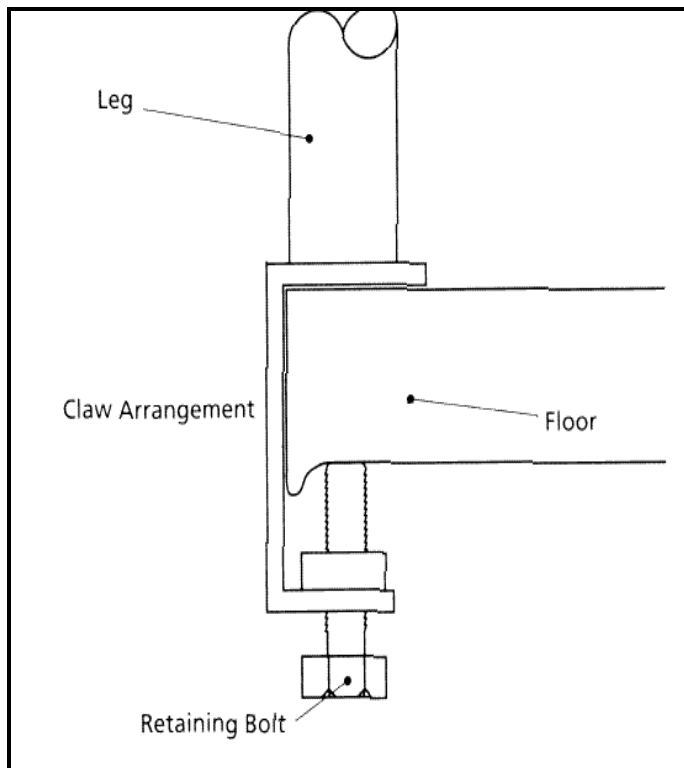

Diagram 8 – Typical angled Claw fitting



03 Seat Belts & Supplementary Restraint Systems

Diagram 9 – Typical parallel Claw fitting



Deficiency	Deficiency Category
1	<b>Obligatory Seat Belt (see table in the application section):</b>
a.	missing. Major
b.	of an incorrect type. Major
2	<b>Anchorage:</b>
a.	(i) with excessive corrosion, serious deterioration or a fracture in a load bearing member of the vehicle structure within 30cm of the anchorage (where a seat belt is attached to a seat frame this will apply to all seat mounting points). Major
	(ii) with excessive corrosion, serious deterioration or a fracture in a load bearing member of the vehicle structure within 30cm of the anchorage (where a seat belt is attached to a seat frame this will apply to all seat mounting points) and is likely to detach. Dangerous*
b.	a seat belt not securely fixed to the seat or to the vehicle structure. Major
3	<b>Locking mechanism, Stalks, Retracting Mechanism and fittings:</b>

03 Seat Belts & Supplementary Restraint Systems

	a.	locking mechanism of a seat belt does not secure or release as intended.	Major
	b.	an attachment or adjustment fitting fractured, badly deteriorated or not operating effectively.	Major
	c.	corrosion or deterioration of a flexible stalk likely to lead to failure under load.	Major
	d.	broken flexible stalk strands.	Major
	e.	a retracting mechanism that does not retract the webbing sufficiently to remove all of the slack from the belt with the locking mechanism fastened and the seat unoccupied.	Major
4		<b>Condition of Webbing:</b>	
	a.	(i) a cut or damage or fluffing or fraying, which is not sufficient to obstruct correct operation of the belt or which has not clearly weakened the webbing.	Minor
		(ii) a cut or damage or fluffing or fraying or overstretching sufficient to obstruct correct operation of the belt or significantly weaken the webbing.	Major
	b.	stitching badly frayed, insecure, incomplete or repaired.	Major
	c.	so dirty that it is likely to soil passengers' clothing.	Minor
5		Obvious signs of structural weakness in a seat belt; fitting, guide, stalk or pivot such that failure is likely.	Major
6		<b>Seats with seat belts attached to them:</b>	
	a.	insecure.	Dangerous*
	b.	with a cracked or fractured leg or frame.	Major
7		<b>A seat belt:</b>	
	a.	load limiter or pretensioner obviously missing where fitted as original equipment.	Major
	b.	pretensioner or a 'folded type' webbing load limiter obviously deployed.	Major
8		<b>An airbag:</b>	
	a.	missing.	Major

## Public Service Vehicle Inspection Manual

### 03 Seat Belts & Supplementary Restraint Systems

	b.	deployed or disconnected.	Major
9		The SRS warning lamp indicates any kind of failure of the system.	Major
10		<b>Installation defect found during annual test:</b>	
	a.	any obvious installation defect found during the inspection.	Major
11		<b>Installation inspection:</b>	
	a.	evidence that original webbing has been cut and/or reworked (eg belts knotted, fraying or fluffing removed/sealed by burning etc.).	Major
	b.	any part of the installation which has a sharp edge which could or is likely to cut or abrade the webbing.	Major
	c.	a directly attached anchorage not secured by standard seat belt mounting bolts and washers as detailed in paragraph D.	Major
	d.	an anchorage insecure.	Major
	e.	a tubular seat frame that has been drilled for the purposed of attaching a seat belt.	Major
	f.	a directly attached anchorage not attached to a load bearing member or without suitable reinforcement.	Major
	g.	retro-fitted three point belt which is not mounted on a suitable structure.	Major
	h.	tubular frame legs or tubular "H" pattern legs which have not been reinforced with buttressing and diagonal bracing, or buttressing where a floor mounted belt is fitted closed to a seat leg.	Major
	i.	belt fitted to a seat which has not been suitable reinforced or modified.	Major
	j.	without suitable padding as detailed in paragraph L.	Major
	k.	lower anchorages less than 320mm apart.	Major
	l.	in such as position that loading the belt causes the cushion to be raised or significantly compressed thus allowing the occupant to effectively move forward.	Major
	m.	an anchorage attached to the floor without reinforcement plates of a suitable size and contour.	Major

## Public Service Vehicle Inspection Manual

### 03 Seat Belts & Supplementary Restraint Systems

n.	with load spreading washer(s) missing from anchorage bolt.	Major
o.	claw type seat mounting with inadequate means of securing. claw	Major
p.	on a seat fitted to a flat rail the bolt does not pass through the leg, rail, floor and a suitable structural member or the floor has not been suitably reinforced.	Major
q.	tracking for securing seats and wheelchairs insecure.	Major
r.	free movement for a looped belt more than 25mm at the anchorage.	Major
s.	upper anchorage of three point belt less than 475mm above uncompressed seat cushion measured parallel to the seat back.	Major
t.	upper anchorage of three point belt(s) less than 110mm from centre line of seat.	Major
u.	incorrect positioning of a lap belt or lap section of a three point belt i.e. the belt lies across the stomach or forward of the top quarter of the thigh.	Major
v.	a seat belt component fitted to a seat significantly intrudes into a gangway and is likely to cause injury to a passenger.	Major
w.	for vehicles subject to enhanced seat belt requirements no evidence that seat belt anchorages are likely to meet the strength requirements of EC Directive 76/115/EC as amended by Directive 96/38/EC.	Major



**Application**

This inspection applies to all Compression Ignition engine vehicles.

Vehicles first used before 1 January 1980 will be subject to a visual examination only, see item 2 in Procedure & Standard and Deficiency sections for more details.

For Hybrid Electric Vehicles (HEV) see ninth bullet point below.

This inspection applies to all Spark Ignition engine vehicles; all are subject to a visual assessment with vehicles used from 1 August 1975 being subject to a visual and metered test using an approved and calibrated exhaust gas analyser to determine the hydrocarbon and carbon monoxide content. For CNG fuelled vehicles, only the CO is to be measured. For vehicles first used from 1 August 1994 the Lambda reading must be assessed.

The inspection of the engine MIL  applies to petrol and diesel fuelled vehicles first used from 1 July 2008. The engine emission system (EES) MIL  is only part of the test where a vehicle is not fitted with the commonly recognised engine MIL.

The engine MIL inspection does not apply to dual fuelled vehicles.

**Procedure and Standards**

**Compression Ignition Engines**

- **Exhaust emissions must be tested** using an approved and calibrated smoke meter.
- **Only in exceptional circumstances where it is not possible to use a smoke meter will a visual check be carried out** (visual tests will not apply to Fast Pass or vehicles submitted for **Low Emission Testing**).
- **If the exhaust has been deliberately modified** to prevent the smoke meter from being used a VTP 12 must be issued refusing to complete the test because the exhaust smoke emissions test cannot be carried out.
- **Twin exhaust systems, with or without a balance pipe** - Both systems must be individually tested for smoke emissions. It may be necessary to purge the exhaust system again prior to the second check.
- **Supercharged engines** should be tested by selecting the non-turbocharged option on the smoke meter.
- **The test procedure** for turbocharged and non-turbocharged engines is the same.
- **It is not normally sufficient** to run the engine with the vehicle stationary to warm it up to temperature, so the emissions should be tested as soon as possible after the vehicle arrives at the test site.
- **With some types of smoke meter** care must be taken to ensure that the probe is correctly aligned to the exhaust gas flow (reference to meter manufacturer's instruction may be necessary).
- **HEVs do not require** a metered smoke test or a visual smoke test. However, if during the test excessive smoke is observed, this will be a deficiency under item 2b.

**Some smoke meters (DSM) may fail to trigger a reading** when testing modern vehicles fitted with low emission diesel engines which produce very low levels of smoke. If the smoke meter does not register a reading or shows an error reading then irrespective of whether the DSM produces a printout a record of this must be made and produced on the test documentation. Where the DSM will not produce a printout, the record must state that the emissions limits were tested and met but the DSM could not register the reading.

**If a vehicle fails the test because the exhaust is holed** the emissions must be rechecked when the vehicle is retested.

**Remember** to issue a printout.

**1. Free acceleration test using smoke meter**

- 1a.
- i. Check that the engine is at or near normal operating temperature.
  - ii. Purge the inlet and exhaust systems fully by holding the engine speed steady at just below maximum governed speed for 30 seconds.
  - iii. Select the appropriate test programme on the smoke meter.
  - iv. Follow the meter prompts; depress the accelerator pedal quickly but not violently, to reach full fuel position in less than 1 second. Hold it there until a release prompt is given. If, at the end of the 1<sup>st</sup> acceleration, the smoke meter value is no more than the appropriate opacity limit required for the vehicle, it will be deemed to have met the test limit.
  - v. After the first acceleration read the smoke level displayed on the meter. If it is greater than the opacity limit for the vehicle, further accelerations will be required up to a maximum of six.
- 1b. Assess visually whether the smoke emitted from the exhaust regardless of the measured density, is likely to obscure the vision of other road users.

**2. Visual emission test**

- 2a.
- i. Only in exceptional circumstances where it is not possible to use a smoke meter will a visual check be carried out. The visual test is only to be used when it is not possible to use the smoke meter or where risk to health and safety would arise. The procedure is the same for supercharged, turbocharged and non-turbocharged engines.
  - ii. With the engine at or near normal operating temperature check the density of the exhaust emission visually.
  - iii. Ask the driver to depress the accelerator pedal quickly but not violently, to reach full fuel position in less than 1 second. Immediately release when the engine reaches its maximum governed speed, allow the engine to return to idle speed.
  - iv. Ignore smoke from the first acceleration.
  - v. Repeat up to a maximum of six times if necessary until the exhaust smoke is considered to be acceptable for two successive accelerations.
- 2b. Assess whether the smoke emitted from the exhaust, regardless of the measured density, is likely to obscure the vision of other road users.

**NOTE:** The criterion is density and not volume of smoke. The description 'dense smoke' includes any smoke or vapour which largely obscures vision.

**Manufacturer's plate value means** either the value displayed on the VIN plate or a separate plate or sticker, which is likely to be within the engine compartment. The plate or sticker may be marked 24 R followed by a number to indicate the smoke limit (such as 0.24 in the example below). It's usually displayed in a box and often positioned in a corner of the VIN plate. The plate value must be used where available and may be of a value lower or higher than the default value.

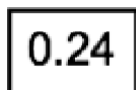

**Where more than one manufacturer's plate value is shown** on a vehicle the less onerous limit must be used.

Generally, the engine MIL takes the form of the commonly recognised engine symbol .

However, some vehicles may only have been manufactured with an EES lamp  in which case this would be subject to test. Examiners must be certain that a deficiency exists before applying deficiency 7.

Where a vehicle is fitted with an engine MIL any illumination of the EES lamp is to be disregarded.

**For all vehicles** check the presence and condition of any emission control systems fitted as standard.

### Spark Ignition Engines

#### 1. Visual Check (all Spark Ignition engine vehicles).

Ensure that the engine is at normal idling speed and operating temperature and is not subject to significant electrical loading. An Assistant may apply light throttle pedal pressure if the engine will not idle.

Raise the engine speed to around 2500rpm or half engine speed if this is lower and hold steady for 20 seconds to purge the exhaust system. Allow the engine speed to return to idle and allow the emissions to stabilise.

Assess the colour of the exhaust smoke.

#### 2. Exhaust Gas Analyser Test (all Spark Ignition engine vehicles used from 1 August 1975)

Follow the analyser manufacturer's instructions and carry out the full test procedure to determine the proportions of carbon monoxide (CO) and hydrocarbon (HC) and Lambda reading where appropriate.

On LPG vehicles the HC result obtained must be divided by the PEF (propane/hexane equivalency factor) marked on the analyser to obtain the figure required to assess the test result. Some machines do this automatically.

Residual hydrocarbons, which are indicated by the analyser when it is sampling clean air, must be deducted from the HC reading for the vehicle.

If a vehicle meets the CO requirement at its **normal idling speed** but fails the HC check, recheck the HC level at a high idle speed of 2000rpm. If the HC reading is then 1200ppm or less, the vehicle will have met the CO and HC requirements. Light pedal pressure should be used to achieve the high idle speed. Cold start/cold running devices must not be used.

Some vehicles give unstable readings due to their fuel system design. Before failing a limit must have been exceeded constantly for at least 5 seconds.

Deficiency	Deficiency Category
<b>Compression Ignition Engines</b>	
<p>1            <b>Statutory Smoke Meter Test:</b></p> <p>    a.        After a total of six accelerations have been completed, the average smoke opacity recorded for accelerations 4, 5 and 6 is more than:</p> <p>              For vehicles used before 1 July 2008:</p> <p>                i.     The level specified by the manufacturer's plate or <math>2.5\text{m}^{-1}</math> for non-turbocharged engines where the plate value is not available.</p> <p>                ii.    The level specified by the manufacturer's plate or <math>3.0\text{m}^{-1}</math> for turbocharged engines where the plate value is not available.</p> <p>              For vehicles first used from 1 July 2008:</p> <p>                iii.   The level specified by the manufacturer's plate or <math>1.5\text{m}^{-1}</math> for all CI engines where the plate value is not available.</p> <p>              For vehicles first used from 1 January 2014:</p> <p>                iv.    The level specified by the manufacturer's plate or <math>0.7\text{m}^{-1}</math> for all CI engines where the plate value is not available.</p>	Major
<p>    b.        The exhaust emits excessive smoke or vapour of any colour, to an extent likely to obscure vision.</p>	Dangerous
<b>2            Statutory Visual Test:</b>	
<p>    a.        After a maximum of six accelerations, the exhaust emits smoke of a level greater than that of equivalent metered levels.</p>	Major
<p>    b.        The exhaust emits excessive smoke or vapour of any colour, to an extent likely to obscure vision.</p>	Dangerous
<b>Spark Ignition Engines</b>	
<b>3            Visual check:</b>	
<p>    a.        The engine is idling at a speed clearly above the normal idling speed.</p>	Major
<p>    b.        The exhaust emits dense blue or clearly visible black smoke for a continuous period of 5 seconds at idling speed.</p>	Dangerous*

4	<b>Exhaust Gas Analyser Check</b>	Major
a.	<b>HC content greater than:</b>	Major
i.	1200ppm for a vehicle first used from 1 August 1975 to 1 august 1994.	
ii.	200ppm for a vehicle first used from 1 August 1994.	
b.	<b>CO content greater than:</b>	Major
i.	4.5% for a vehicle first used from 1 August 1975 to 31 July 1986.	
ii.	3.5% for a vehicle first used from 1 August 1986 to 1 August 1994 and any LPG/CNG/LNG fuelled vehicles used from 1 August 1975.	
iii.	0.2% at <b>fast idle</b> (2500 - 3000 rpm) for a vehicle first used from 1 August 1994	
iv.	0.3% at <b>idle</b> (450 - 1500 rpm) or a vehicle first used from 1 August 1994	
c.	<b>Lambda not between</b>	Major
	0.97 and 1.03 for a vehicle first used from 1 August 1994	
<b>All vehicles</b>		
5	Emission control equipment fitted by the manufacturer absent, or obviously defective or shows any signs of obvious tampering.	Major
6	A vehicle equipped with a Diesel Particulate Filter shows any visible signs of smoke.	Major
7	Engine MIL inoperative or indicating a malfunction.	Major

**Application**

This inspection applies to all road wheels and hubs apart from spare wheels.

**Procedure and Standards**

**Where possible wheel nuts will be lightly tapped** with a hammer to check for looseness, but any other evidence such as rust marks or elongation of bolt/stud holes must also be taken into account.

**A nut or stud is considered to be “loose”** if it is not obviously carrying out its function of clamping the wheel to the hub/wheel flange.

**With some vehicles it is not possible to see the road wheels completely** from ground level, especially with twin wheels and where the body hides part of the wheels. In such cases the vehicle must be moved to expose hidden parts of the wheels or examined from underneath.

**Before attending the test**, presenters should remove wheel embellishers or wheel nut covers if they prevent a full examination. If these are present at test, the presenter may be asked to remove them. Where this cannot be accomplished, continue to inspect the vehicle and an advisory must be recorded on the test documentation to state that the embellishers were not removed.

**A 'wheel flange' is a component** which is positioned between the road wheel and the hub which contains the wheel studs.

**Capacity Limitations of 11.75 x 22.5 Alcoa Aluminium Wheels.**

Wheels with the part number 813520/813523 may be stamped on the inside of the wheel, opposite the valve, with a maximum load rating of 4250kg or 4500kg and those with part number 813530/813533 with a rating of 4500kg. It has been agreed that wheels with these part numbers and maximum load ratings are suitable for a maximum axle weight of 9150kg.

**Kronprinz wheels fitted** to the Dennis range of vehicles specifically the Trident 2 and the Enviro 400 identified by an 'X' as the 12<sup>th</sup> character of the VIN, are capable of carrying higher loads than those shown on the wheels. The wheels can be identified by the following markings on the wheel face:

848MGF	and	848SAF
148/145		149/145
KpZ		KpZ

The 148 and 149 indexes in single configuration are normally only good for 6300kg and 6500kg respectively. Kronprinz have informed DVSA that these wheels are actually good for 7100kg and 7500kg respectively. If you come across these wheels at annual test please be aware of the increase in weight.

**Capacity limitation of a wheel marked with a load index**

If a wheel is marked with a load index which indicates that the maximum load is lower than is required to support the axle load, this will be a deficiency under 2.f.

**Wheels not marked with a load index or load marking** must be assumed to be capable of carrying the axle weight.

## Compatibility of Wheel Fixings

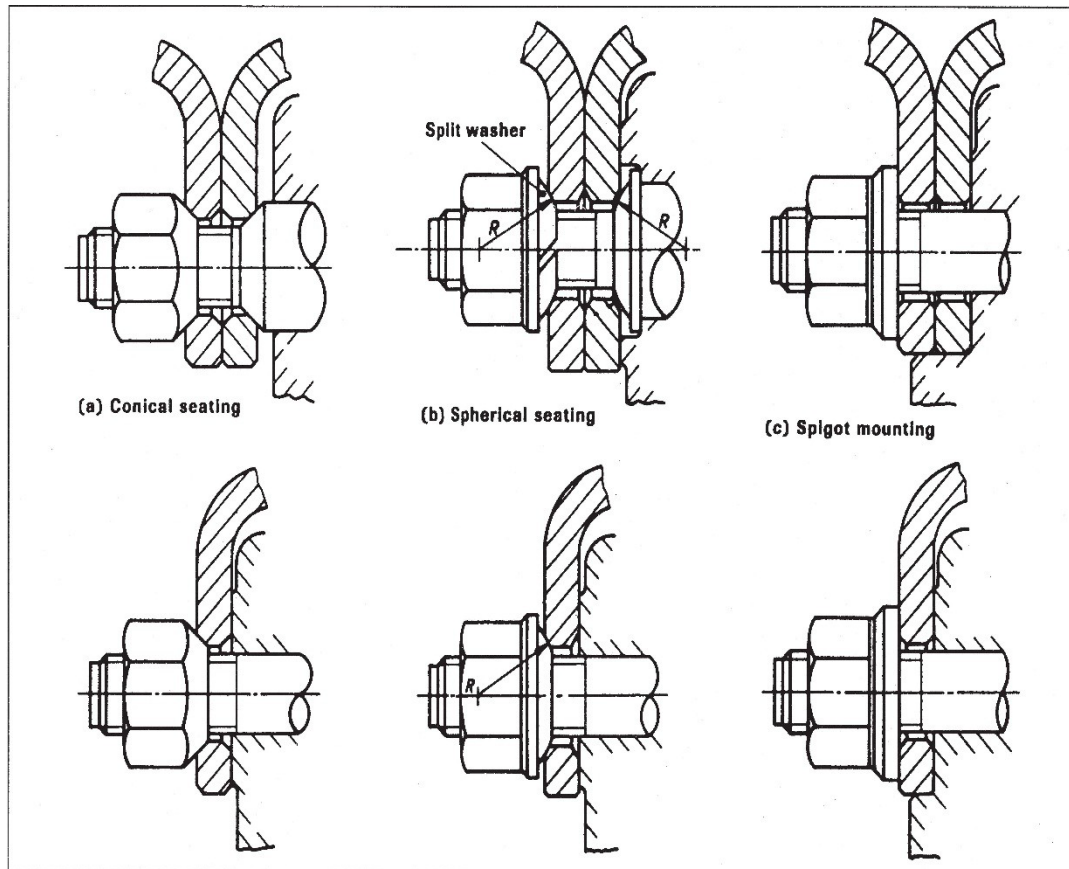

Vehicles with conical wheel fixings **MUST NOT** be fitted with wheels from vehicles designed for use with spherical fixings. (British built vehicles normally have conical wheel fixings).

Vehicles with spherical wheel fixings **MUST NOT** be fitted with wheels from vehicles which are designed for use with conical fixings.

Volvo wheels of the original spigot-mounting design **WILL NOT** interchange with another type. Volvo wheels designed for later type spigot mounting may be used in an emergency on British built trailers.

Wheels with conical fixings **MUST NOT** be used on Volvo vehicles because they do not have a machine centre bore to fit the hub.

Spigots must extend to the outer wheel where twin wheels are fitted.

Wheel trims should be removed where possible to aid inspection; however, wheel nuts and studs must not be removed to check compatibility. Deficiency 2c only applies where obvious evidence exists that a wheel is not compatible with its hub and/or fixings.

**Sleeved two piece flange nut fixing**

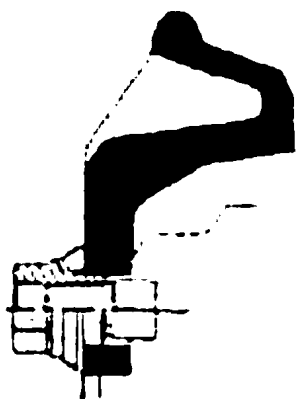

**Single wheel location**

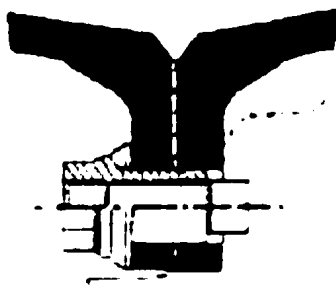

**Twin Wheel Spigot Mounting**

Sleeved two piece flange nut fixing, this fixing method of utilising a sleeved nut has been adopted primarily to allow the retro fitting of aluminium wheels which incorporate a thicker flange.

**Where wheel trim brackets are secured by the wheel retaining nuts** it is acceptable provided the bracket does not stop the wheel nut from seating correctly in the taper of the stud hole. For spigot mounted wheels there may be some overlap between the washer and bracket, this will only be considered a defect where the nut clamping force is obviously ineffective.

**When assessing corroded road wheels**, the effects on any wheel stud or nut functionality (clamping the wheel to a hub or wheel flange) must be considered.

**Some wheel nut studs do not protrude all the way through the wheel nut** this is acceptable provided there is no sign of insecurity.

**Where twin wheels are fitted** the spigots must extend to the outer wheel to locate this.

Deficiency		Deficiency Category
1	<b>A tyre retaining ring:</b>	
a.	fractured or not properly fitted such that detachment is likely.	Dangerous*
b.	butting causing the flange to lift more than 1.5mm from the rim and/or not properly fitted.	Major

# Public Service Vehicle Inspection Manual

## 06 Road Wheels and Hubs

2	<b>A wheel:</b>	
a.	(i) with any visible elongation of a stud hole.	Major
	(ii) with any visible elongation of a stud hole where secure fixing of the wheel is affected.	Dangerous
b.	(i) badly damaged or distorted (including damaged by the corners of a wheel nut cutting into the material of the wheel).	Major
	(ii) badly damaged or distorted (including damaged by the corners of a wheel nut cutting into the material of the wheel) where secure fixing of the wheel is affected.	Dangerous
c.	not compatible with its fixings.	Major
d.	cracked (except at the bridge over the valve), weld breaking away or an inadequate repair.	Dangerous*
e.	made of aluminium alloy repaired by welding.	Major
f.	with a load rating less than that required to support the maximum permissible (GB) axle load.	Major
3	<b>A hub:</b>	
a.	(i) cracked, badly damaged, or with a half shaft or wheel flange bolt, stud or nut loose or missing.	Major
	(ii) cracked, badly damaged, or with half shaft bolts or wheel flange bolts, studs or nuts loose or missing where secure fixing of the wheel is affected.	Dangerous
b.	with clearance between a spigot mounted wheel and the hub spigots that exceeds 3mm across the diameter.	Major
c.	(i) with a wheel retaining nut or stud missing or loose or obviously not fulfilling the function of clamping the wheel to the hub.	Major
	(ii) with multiple wheel retaining nuts or studs missing or loose or obviously not fulfilling the function of clamping the wheel to the hub.	Dangerous
d.	with a spigot wheel nut washer cracked.	Major
e.	with a wheel locating spigot or dowel missing.	Major

07 Size and Type of Tyres

<b>Application</b>		
This inspection applies to all tyres, apart from spare tyres.		
<b>Procedure and Standards</b>		
<p><b>The use markings most likely to be encountered</b> are 'FRT' which indicates that the tyre is not suitable for use on a driven axle or front steered axle. Tyres marked 'TRAILER USE ONLY' are only suitable for use on trailers, some tyres may be branded for a recommended use while still suitable for other applications. Tyres marked with a direction arrow pointing in the wrong direction should not be refused.</p> <p><b>Tyres are usually identified by their nominal section size followed by the rim diameter</b> e.g. 10.00-20,750-16, etc (the majority of modern tyres carry millimetric markings e.g. 205-16 etc). For identification of sidewall markings refer to the diagram at the end of this section. All tyres on an axle must be of the same nominal size. If a tyre is dual marked one of the markings must be the same as the markings on the other tyres on the axle.</p> <p><b>There are still a number of high load capacity tyres in use</b> which are marked with a code to indicate the tyre size and capacity e.g. a 10.00-20 16 ply tyre may be marked D20 or 4-20 (a full list of these tyres is given at Table 1).</p> <p><b>If tyres marked with a load capacity index are fitted</b> the maximum permissible axle Load for normal use can be found in Table 2 at the end of this section. The Load Index (LI) may consist of one or two numbers e.g. 154 or 146/143. Where two numbers are displayed the first refers to the use of the tyre in single formation and the second in twin formation. Reference to the table shows that the maximum loads for this tyre are 6000kg in single formation and 10900 in twin formation. If the load index branded onto a tyre has the speed symbol missing (not scrubbed off), the load index is not valid and must be ignored.</p> <p><b>If a load index is not shown</b> the carrying capacity of a tyre can be determined from the Ply Rating. The load capacity of ply rated tyres is shown at Table 3. If no ply rating can be found on the tyre it should be assumed to have the lowest load capacity listed for that size of tyre.</p> <p>This information relates to tyres used without any restriction. There are two other categories of vehicle use which allow tyres to be operated at lower speeds and higher loads. These are Local Service Bus and Restricted Speed Vehicle (i.e. a vehicle displaying a 50 plate), both of which are restricted to a maximum speed of 50 mph.</p> <p><b>SPEED SYMBOLS</b></p> <p>A load index branded onto a tyre must be followed by a speed rating. If <b>no</b> speed rating is visible due to it being scrubbed off by wear it must be assumed that the minimum requirements are met, and the customer advised.</p> <p>The speed capability is represented by a letter which is displayed adjacent to the LI marking e.g. 146/143J. This indicates the speed at which the tyre can carry the load(s) indicated by the LI marking(s). In the above example the tyres carry a load of 6000/10900kg at 62mph.</p> <p><b>The minimum required speed ratings are:</b></p>		
OF VEHICLE	PERMITTED SPEED (MPH)	MINIMUM SPEED SYMBOL
Any bus not exceeding 12 metres in length other than a "Local Service Bus" or a "Restricted speed vehicle" <b>CLASS</b>	70	L

07 Size and Type of Tyres

Any bus exceeding 12 metres in length other than a “Local Service Bus” or a “Restricted speed vehicle”	60	J
A “Local Service Bus” or a “Restricted speed vehicle”	50	F

**Alternative Speed Rating**

Certain vehicles can be fitted with tyres showing a lower speed rating than those shown above but the maximum axle loads will be reduced as shown below.

CLASS OF VEHICLE	NORMAL SPEED RATING	ALTERNATIVE SPEED RATING	CHANGE IN AXLE LOADS
A bus not exceeding 12 metres in length other than a “Local Service Bus” or a “Restricted speed vehicle”	L	J	-7%
		K	-3%
Any bus exceeding 12 metres in length other than a “Local Service Bus” or a “Restricted speed vehicle”	J	F	-15%
		G	-5%
A “Local Service Bus” or a “Restricted speed vehicle”	F	J or higher	+10% (+15 % for vehicles approved under 92/23/EEC)

Details of the reduced axle loads which tyres can carry are shown in Table 4.

**Structure**

Examine all the tyres fitted and note the type of structure (radial, cross-ply or bias-belted) and the nominal size of tyres.

All tyres on an axle must be of the same structure and nominal size.

Tyres on an axle may be of different structures and nominal sizes to those on another axle with the following exceptions:

- All tyres on all steered axles must have the same structure.
- All tyres on all driven axles must have the same structure.
- On two axle motor vehicles where each axle is fitted with single wheels, if all the tyres are not of the same structure, the type of structure which is allowed to be fitted to each axle is shown in the table.

07 Size and Type of Tyres

Axle 1	Axle 2
Cross-ply	Bias-belted
Cross-ply	Radial
Bias-belted	Radial

This does not apply to an axle on which wide single tyres with a road contact width of more than 300mm are fitted.

**TABLE 1**

CODE	TYRE SIZE
A16 or 1 — 16	750 — 16 —12 PR
B16 or 2 — 16	825 — 16 —14PR
C16 or 3 — 16	900 — 16 —14 PR
B17 or 2 — 17	825 — 17—14 PR
A20 or 1 — 20	750 — 20 —12 PR
B20 or 2 — 20	825 — 20 —14 PR
C20 or 3 — 20	900 — 20 —14 PR
D20 or 4 — 20	1000 — 20 —16 PR
E20 or 5 — 20	1100 — 20 —16 PR
F20	1200 — 20 —18 PR
G20	1400 — 20 —22 PR
E22 or 5 — 22	1100 — 22 —16 PR
B22.5 or 2 — 22.5	9 — 22.5 —14 PR
C22.5 or 3 — 22.5	10 — 22.5 —14 PR
D22.5 or 4 — 22.5	11— 22.5 —16 PR
E22.5	12— 22.5 —16 PR
C24 or 3 — 24	900 — 24 —14 PR
E24	1100 — 24 —16 PR

**07 Size and Type of Tyres**

**Table 2** Load capacity index table

Extract from ECE Reg 54: "Load index" Table amended to show axle loads

Load Index	Single Kg	Dual Kg	Load Index	Single Kg	Dual Kg	Load Index	Single Kg	Dual Kg
70	670	1340	110	2120	4240	150	6700	13400
71	690	1380	111	2180	4360	151	6900	13800
72	710	1420	112	2240	4480	152	7100	14200
73	730	1460	113	2300	4600	153	7300	14600
74	750	1500	114	2360	4720	154	7500	15000
75	774	1548	115	2430	4860	155	7750	15500
76	800	1600	116	2500	5000	156	8000	16000
77	824	1648	117	2570	5140	157	8250	16500
78	850	1700	118	2640	5280	158	8500	17000
79	874	1748	119	2720	5440	159	8750	17500
80	900	1800	120	2800	5600	160	9000	18000
81	924	1848	121	2900	5800	161	9250	18500
82	950	1900	122	3000	6000	162	9500	19000
83	974	1948	123	3100	6200	163	9750	19500
84	1000	2000	124	3200	6400	164	10000	20000
85	1030	2060	125	3300	6600	165	10300	20600
86	1060	2120	126	3400	6800	166	10600	21200
87	1090	2180	127	3500	7000	167	10900	21800
88	1120	2240	128	3600	7200	168	11200	22400
89	1160	2320	129	3700	7400	169	11600	23200
90	1200	2400	130	3800	7600	170	12000	24000
91	1230	2460	131	3900	7800	171	12300	24600
92	1260	2520	132	4000	8000	172	12600	25200
93	1300	2600	133	4120	8240	173	13000	26000
94	1340	2680	134	4240	8480	174	13400	26800
95	1380	2760	135	4360	8720	175	13800	27600
96	1420	2840	136	4480	8960	176	14200	28400
97	1460	2920	137	4600	9200	177	14600	29200
98	1500	3000	138	4720	9440	178	15000	30000
99	1550	3100	139	4860	9720	179	15500	31000
100	1600	3200	140	5000	10000			
101	1650	3300	141	5150	10300			
102	1700	3400	142	5300	10600			
103	1750	3500	143	5450	10900			
104	1800	3600	144	5600	11200			
105	1850	3700	145	5800	11600			
106	1900	3800	146	6000	12000			
107	1950	3900	147	6150	12300			
108	2000	4000	148	6300	12600			
109	2060	4120	149	6500	13000			

07 Size and Type of Tyres

1. Ply Rating Marked Tyres

How to use this table:

1. Locate the line entry corresponding to the size and ply rating marked on the tyre sidewall;
2. Read off the maximum axle load (kg) for these tyres in 'SINGLE' or 'TWIN' formation, as appropriate.

TABLE 3

Nominal Tyre Size	Ply Rating	Maximum Axle Load (Kg)	
		Single Tyres	Twin Tyres
145-13C	6	970	1840
145-13C	8	1120	2120
560-13C	6	1020	1940
590-13C	6	1070	2090
640-13C	6	1280	2240
640-13C	8	1430	2750
670-13C	6	1380	2650
670-13C	8	1580	3050
1050-13	12	4320	7880
1050-13	14	4830	8900
155-14C	6	1070	2040
165-14C	6	1300	2460
165-14C	8	1460	2760
175-14C	6	1430	2680
175-14C	8	1550	3000
185-14	RADIAL	1200	2300
185-14	REINFORCED RAD	1340	2560
185-14	4	1340	2560
185-14C	6	1550	2920
185-14C	8	1700	3200
195-14	RADIAL	1300	2490
195-14	REINFORCED RAD	1500	2870
195-14C	6	1700	3210
195-14C	8	1900	3600
205-14	RADIAL	1420	2720
205-14	REINFORCED RAD	1650	3160
205-14C	6	1850	3510
205-14C	8	2060	3900
215-14C	8	2240	4240
590-14C	6	1170	2240
600-14C	8	1260	2400

Nominal Tyre Size	Ply Rating	Maximum Axle Load (Kg)	
		Single Tyres	Twin Tyres
640-14C	6	1330	2550
650-14	4	970	1860
650-14C	6	1300	2460
650-14C	8	1500	2840
670-14C	6	1430	2750
670-14C	8	1680	3160
700-14	4	1070	2050
700-14C	6	1380	2650
750-14	4	1200	2300
750-14C	6	1530	2950
750-14C	8	1730	3360
11-15	6	2240	—
145-15C	8	1230	2320
185-15C	8	1750	3400
590-15C	6	1220	2340
640-15C	6	1380	2650
670-15C	6	1530	2900
670-15C	8	1780	3460
670-15	10	2000	3900
700-15C	6	1750	3400
700-15C	8	1940	3760
700-15	12	2440	4580
750-15C	6	1830	3560
750-15C	8	2060	3970
750-15	10	2340	4370
750-15	12	2750	5340
750-15	14	3150	6100
750-15	16	3660	6860
825-15	12	3050	5590
825-15	14	3360	6360
825-15	18	4680	8540
825-15	20	5000	9440
1000-15	12	3870	7120
1000-15	14	4320	8130
1000-15	16	5020	9580
1000-15	18	5400	10170

Nominal Tyre Size	Ply Rating	Maximum Axle Load (Kg)	
		Single Tyres	Twin Tyres
175-16C	6	1500	2840
175-16C	8	1650	3100
185-16C	8	1800	3400
195-16C	8	1950	3700
205-16C	6	1900	3610
205-16C	8	2120	4000
215-16C	6	2120	4000
215-16C	8	2300	4360
235-85-16	10	2760	5040
600-16	6	1380	2550
600-16	8	1530	2920
600-16	10	1830	3300
650-16	6	1530	2920
650-16	8	1830	3460
650-16	10	2040	3900
700-16	6	1730	3260
700-16	8	2040	3870
700-16	10	2340	4480
700-16	12	2650	5000
750-16	6	2040	3870
750-16	8	2240	4270
750-16	10	2500	4720
750-16	12	2900	5600
825-16	8	2650	4880
825-16	10	2850	5440
825-16	12	3300	6400
825-16	14	3600	6800
900-16	6	2360	4360
900-16	8	2720	5140
900-16	10	3050	5600
900-16	12	4070	7200
900-16	14	4320	7800
1050-15	12	4580	8130

Nominal Tyre Size	Ply Rating	Maximum Axle Load (Kg)	
		Single Tyres	Twin Tyres
1400-16	18	7880	—
1400-16	20	8390	—
1400-16	22	9150	—
9.50-16.5	6	2130	3750
825-17	10	3260	5850
825-17	12	3560	6200
825-17	14	3820	7200
8-17.5C	8	2300	4480
8-17.5	10	2570	5000
8.5-17.5	RADIAL	2900	5600
9.5-17.5	RADIAL	3400	6400
8-19.5	RADIAL	3100	6000
9-19.5	RADIAL	3800	7200
9.5-19.5	RADIAL	4240	7800
600-20	6	1430	2750
600-20	8	1630	3100
600-20	10	1830	3460
650-20	6	1830	3460
650-20	8	2240	4070
650-20	10	2440	4680
700-20	8	2240	4480
700-20	10	2650	4880
700-20	12	2850	5340
750-20	8	2850	5340
750-20	10	3260	6000
750-20	12	3600	7000
825-20	10	3560	6610
825-20	12	3820	7200
825-20	14	4120	7800
900-20	10	4070	7630
900-20	12	4580	8240
900-20	14	5000	9200

Nominal Tyre Size	Ply Rating	Maximum Axle Load (Kg)	
		Single Tyres	Twin Tyres
1000-20	12	4830	8640
1000-20	14	5340	9720
1000-20	16	6100	10900
10.5-20	6	2800	—
1100-20	12	5340	9660
1100-20	14	6100	10900
1100-20	16	6610	11600
1200-20	14	6100	10600
1200-20	16	6860	12000
1200-20	18	7630	13010
12.5-20	10	3700	—
1300-20	16	7800	—
1300-20	18	8900	—
1300-20	20	*9300	—
1400-20	18	9150	—
1400-20	20	*9510	—
1400-20	22	*10000	—
14.5-20	10	4000	—
1500-20	20	10600	—
1500-20	22	11600	—
1500-20	24	12600	—
1600-20	14	6100	—
1600-20	20	11400	—
1600-20	22	12500	—
1600-20	24	13600	—
1380-20	18	7300	13000
1480-20	18	8250	—
1100-22	12	5590	10170
1100-22	14	6100	10810
1100-22	16	6860	12000

Nominal Tyre Size	Ply Rating	Maximum Axle Load (Kg)	
		Single Tyres	Twin Tyres
9-22.5	10	3560	6610
9-22.5	12	3820	7200
9-22.5	14	4120	7800
10-22.5	10	4070	7630
10-22.5	12	4580	8240
10-22.5	14	5000	9200
11-22.5	12	4830	8640
11-22.5	14	5340	9720
11-22.5	16	6100	10900
13-22.5	18	7500	13000
10/70-22.5	14	5000	9200
11/70-22.5	12	5300	9720
11/70-22.5	14	5600	10300
11/70-22.5	16	6100	10900
12/70-22.5	16	6610	11600
13/70-22.5	18	7630	13010
275/20-22.5	RADIAL	5000	9200
275/70-22.5	16	6100	—
315/70-22.5	16	6610	11600
900-24	12	5090	9150
900-24	14	5340	10170
1000-24	14	6100	10500
1100-24	12	5850	10300
1100-24	14	6610	11200
1100-24	16	7120	12300
1200-24	14	6610	—
1200-24	16	7370	—
1200-24	18	8130	—
1200-24	20	9000	—
1400-24	18	10000	—
1400-24	22	11200	—
11-24.5	14	5830	10800

Note: Items marked '\*' are not suitable in UK over 9200kg due to minimum tread width requirement of 300mm

**Public Service Vehicle Inspection Manual**

**07 Size and Type of Tyres**

**TABLE 4 MAX AXLE LOADS FOR "UNRESTRICTED" SPEED VEHICLES**

Tyre load Index	Trailers permitted to exceed 50mph (up to 60mph)				Motor vehicles permitted to exceed 60mph (up to 70mph)			
	Speed Symbol F (-15%)		Speed Symbol G (-5%)		Speed Symbol J (-7%)		Speed Symbol K (-3%)	
	Single Kg	Dual Kg	Single Kg	Dual Kg	Single Kg	Dual Kg	Single Kg	Dual Kg
70	570	1140	640	1280	630	1250	650	1300
71	590	1180	660	1320	650	1290	670	1340
72	610	1210	680	1350	660	1330	690	1380
73	630	1250	700	1390	680	1360	710	1420
74	640	1280	720	1430	700	1400	730	1460
75	660	1320	740	1480	720	1440	760	1510
76	680	1360	760	1520	750	1490	780	1560
77	700	1410	790	1570	770	1540	800	1600
78	730	1450	810	1620	800	1590	830	1650
79	750	1490	830	1670	820	1630	850	1700
80	770	1530	860	1710	840	1680	880	1750
81	790	1580	880	1760	860	1720	900	1800
82	810	1620	910	1810	890	1770	930	1850
83	830	1660	930	1860	910	1820	950	1890
84	850	1700	950	1900	930	1860	970	1940
85	880	1760	980	1960	960	1920	1000	2000
86	910	1810	1010	2020	990	1980	1030	2060
87	930	1860	1040	2080	1020	2030	1060	2120
88	960	1910	1070	2130	1050	2090	1090	2180
89	990	1980	1110	2210	1080	2160	1130	2250
90	1020	2040	1140	2280	1120	2240	1170	2330
91	1050	2100	1170	2340	1150	2290	1200	2390
92	1080	2150	1200	2400	1180	2350	1230	2450
93	1110	2210	1240	2470	1210	2420	1270	2530
94	1140	2280	1280	2550	1250	2500	1300	2600
95	1180	2350	1320	2630	1290	2570	1340	2680
96	1210	2420	1350	2700	1330	2650	1380	2760
97	1250	2490	1390	2780	1360	2720	1420	2840
98	1280	2550	1430	2850	1400	2790	1460	2910
99	1320	2640	1480	2950	1450	2890	1510	3010
100	1360	2720	1520	3040	1490	2980	1560	3110
101	1410	2810	1570	3140	1540	3070	1610	3210
102	1450	2890	1620	3230	1590	3170	1650	3300
103	1490	2980	1670	3330	1630	3260	1700	3400
104	1530	3060	1710	3420	1680	3350	1750	3500
105	1580	3150	1760	3520	1730	3450	1800	3590
106	1620	3230	1810	3610	1770	3540	1850	3690
107	1660	3320	1860	3710	1820	3630	1900	3790
108	1700	3400	1900	3800	1860	3720	1940	3880
109	1760	3510	1960	3920	1920	3840	2000	4000
110	1810	3610	2020	4030	1980	3950	2060	4120
111	1860	3710	2080	4150	2030	4060	2120	4230
112	1910	3810	2130	4260	2090	4170	2180	4350
113	1960	3910	2190	4370	2140	4280	2240	4470
114	2010	4020	2250	4580	2200	4390	2290	4580
115	2070	4140	2310	4620	2260	4520	2360	4720
116	2130	4250	2380	4750	2330	4650	2430	4850
117	2190	4370	2450	4890	2390	4780	2500	4990

**Public Service Vehicle Inspection Manual**

**07 Size and Type of Tyres**

**TABLE 4 (continued) MAX AXLE LOADS FOR “UNRESTRICTED” SPEED VEHICLES**

Tyre load Index	Trailers permitted to exceed 50mph (up to 60mph)				Motor vehicles permitted to exceed 60mph (up to 70mph)			
	Speed Symbol F (-15%)		Speed Symbol G (-5%)		Speed Symbol J (-7%)		Speed Symbol K (-3%)	
	Single Kg	Dual Kg	Single Kg	Dual Kg	Single Kg	Dual Kg	Single Kg	Dual Kg
118	2250	4490	2510	5020	2460	4910	2570	5130
119	2320	4630	2590	5170	2530	5060	2640	5280
120	2380	4760	2660	5320	2610	5210	2720	5440
121	2470	4930	2760	5510	2700	5400	2820	5626
122	2550	5100	2850	5700	2790	5580	2910	5820
123	2640	5270	2950	5890	2890	5770	3010	6020
124	2720	5440	3040	6080	2980	5960	3110	6210
125	2810	5610	3140	6270	3070	6140	3210	6410
126	2890	5780	3230	6460	3170	6330	3300	6600
127	2980	5950	3330	6650	3260	6510	3400	6790
128	3060	6120	3420	6840	3350	6700	3500	6990
129	3150	6290	3520	7030	3450	6890	3590	7180
130	3230	6460	3610	7220	3540	7070	3690	7380
131	3320	6630	3710	7410	3630	7260	3790	7570
132	3400	6800	3800	7600	3720	7440	3880	7760
133	3510	7010	3920	7830	3840	7670	4000	8000
134	3610	7210	4030	8060	3950	7890	4120	8230
135	3710	7420	4150	8290	4060	8110	4230	8460
136	3810	7620	4260	8520	4170	8340	4350	8700
137	3910	7820	4370	8740	4280	8560	4470	8930
138	4020	8030	4490	8970	4390	8780	4580	9160
139	4140	8270	4620	9240	4520	9040	4720	9430
140	4250	8500	4750	9500	4650	9300	4850	9700
141	4380	8760	4900	9790	4790	9580	5000	10000
142	4510	9010	5040	10070	4930	9860	5150	10290
143	4640	9270	5180	10360	5070	10140	5290	10580
144	4760	9520	5320	10640	5210	10420	5420	10870
145	4930	9860	5510	11020	5400	10790	5630	11260
146	5100	10200	5700	11400	5580	11160	5820	11640
147	5230	10460	5850	11690	5720	11440	5970	11940
148	5360	10710	5990	11970	5860	11720	6120	12230
149	5530	11050	6180	12350	6050	12090	6310	12610
150	5700	11390	6370	12730	6240	12470	6500	13000
151	5870	11730	6560	13110	6420	12840	6700	13390
152	6040	12070	6750	13490	6610	13210	6890	13780
153	6210	12140	6940	13870	6790	13580	7090	14170
154	6380	12750	7130	14250	6980	13950	7280	14550
155	6590	13180	7370	14730	7210	14420	7520	15040
156	6800	13600	7600	15200	7440	14880	7760	15520
157	7020	14030	7840	15680	7680	15350	8010	16010
158	7230	14450	8080	16150	7910	15810	8250	16490
159	7440	14880	8320	16630	8140	16280	8490	16980
160	7650	15300	8550	17100	8370	16740	8730	17460
161	7870	15730	8790	17580	8610	17210	8980	17950
162	8080	16150	9030	18050	8840	17670	9220	18430
163	8290	16580	9270	18530	9070	18140	9460	18920
164	8500	17000	9500	19000	9300	18600	9700	19400

07 Size and Type of Tyres

Tyre load Index	Trailers permitted to exceed 50mph (up to 60mph)				Motor vehicles permitted to exceed 60mph (up to 70mph)			
	Speed Symbol F (-15%)		Speed Symbol G (-5%)		Speed Symbol J (-7%)		Speed Symbol K (-3%)	
	Single Kg	Dual Kg	Single Kg	Dual Kg	Single Kg	Dual Kg	Single Kg	Dual Kg
165	8760	17510	9790	19570	9580	19160	10000	19990
166	9010	18020	10070	20140	9860	19720	10290	20570
167	9270	18530	70360	20710	10140	20280	10580	21150
168	9520	19040	10640	21280	10420	20840	10870	21730
169	9860	19720	11020	22040	10790	21580	11260	22510
170	10200	20400	11400	22800	11160	22320	11640	23280
171	10460	20910	11690	23370	11440	22880	11940	23870
172	10710	21420	11970	23940	11720	23440	12230	24450
173	11050	22100	12350	24700	12090	24180	12610	25220
174	11390	22780	12730	25460	12470	24930	13000	26000
175	11730	23460	13110	26220	12840	25670	13390	26780
176	12070	24140	13490	26980	13210	26420	13780	27550
177	12410	24820	13870	27740	13580	27160	14170	28330
178	12750	25500	14250	28500	13950	27900	14550	29100
179	13180	26350	14730	29450	14420	28830	15040	30070

REPRODUCED BY COURTESY OF THE BRITISH RUBBER MANUFACTURERS ASSOCIATION

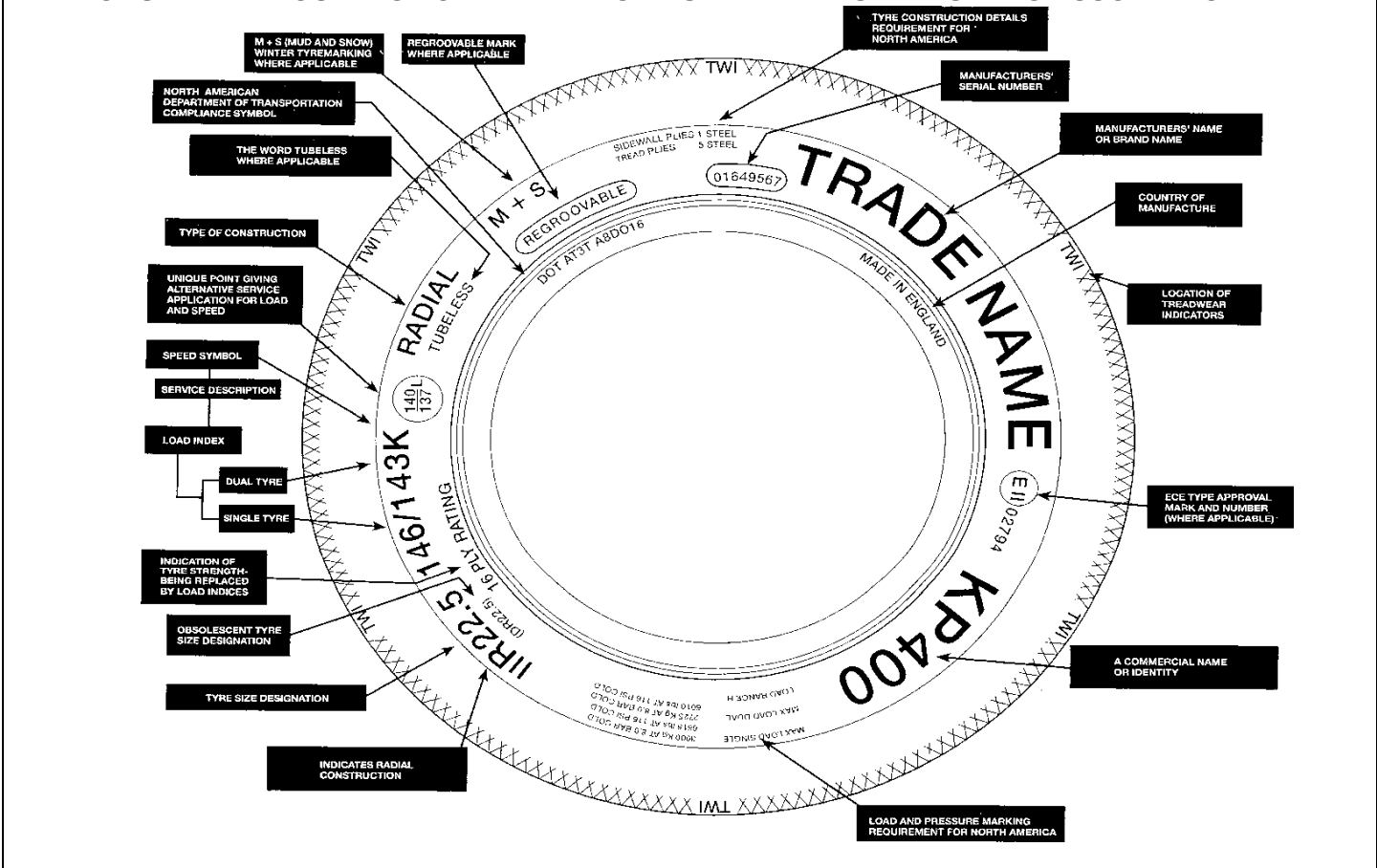

# Public Service Vehicle Inspection Manual

## 07 Size and Type of Tyres

Deficiency	Deficiency Category
<p>1            <b>A tyre:</b></p> <p>a. (i) of which the nominal size, ply rating, load index or speed rating of any tyre is below that appropriate for the axle weight.            Major</p> <p>          (ii) of which the nominal size, ply rating, load index or speed rating of any tyre is below that appropriate for the axle weight and is loaded at least 10% in excess of the tyre load index/ply rating.            Dangerous</p> <p>b. which has a tyre use marking inappropriate for the type of axle or vehicle to which it is fitted.            Major</p> <p>c. of a different nominal size to another on the same axle.            Major</p> <p>d. of a different structure to another on the same axle.            Dangerous*</p> <p>e. on a steerable axle which is not of the same structure as any other tyre on any steerable axle.            Dangerous*</p> <p>f. on a driven axle which is not of the same structure as any other tyre on any driven axle.            Dangerous*</p>	
<p>2            On a two-axle motor vehicle fitted with single tyres on both axles a combination of tyres with structures which are not shown as acceptable in the table.</p>	<p>Dangerous*</p>

08 Condition of Tyres

**Application**

The examination for tyre condition applies to all tyres apart from spare tyres.

The check for tyre age code markings will apply to all axles on all vehicles.

Tyre age will only be assessed on front steered axles and rear axles on minibuses with a single wheel fitment (including multiple axle configurations with single wheel fitment).

**Procedure and standards**

**Lifting of the tread rubber** is a deficiency.

**If a portion of the tread material is partially severed** so that it is likely to fly off and cause danger for other road users is a deficiency.

**The following criteria should be used when assessing a cut in a tyre:**

1. Any ply or cord that can be seen without touching the tyre would be a deficiency under 1c.
2. If by folding back rubber or opening a cut with a blunt instrument, so as not to cause further damage, exposed ply or cord can be seen irrespective of the size of the cut this would be a deficiency under 1c.
3. If a cut which is more than 25mm or 10% of the section width whichever is the greater, is opened with a blunt instrument and cords can be felt but not seen this would be a deficiency under 1a.

Before failing a cut as listed in 3 above, you must ensure that it is definitely the cords that are felt and not a foreign object.

**When checking bulges care must be taken** to distinguish between bulges caused by separation or partial failure of the structure and the bulges which are due to normal manufacturing undulations in the tyre or due to a satisfactory repair. A bulge due to a repair will be solid, feeling firm to hand pressure and will not deflect as would a bulge associated with casing separation.

**Recapped tyres may show unbonded surplus** rubber at the tyre shoulder which may give the appearance of tread separation, this is not a deficiency.

**When checking any tyre that appears to have been recut** to determine whether it has been recut to the manufacturers recut tread pattern. It is often difficult to identify tyres which have been skilfully recut, but extra care should be taken to check for exposure of the ply or cord at the bottom of the grooves.

Recut tyres can only be fitted to motor vehicles with an unladen weight of 2540kg or more and to trailers with an unladen weight of more than 1020kg.

08 Condition of Tyres

Note: The original tread pattern means:

- On a re-treaded tyre the tread pattern immediately after the tyre was retreaded.
- On a recut tyre the manufacturer's recut tread pattern.
- On a partly recut tyre, the part which has been recut the manufacturer's recut tread pattern, on the other part the tread pattern when new.
- On any other tyre the tread pattern of the tyre when new.

When checking the tread pattern, the "Breadth of Tread" is to be taken as that part of the tyre which can contact the road, under normal use, measured across the tyre.

The following should be disregarded when deciding which grooves need to be checked in regard to the "original tread pattern".

- Grooves which wear out before the main grooves are worn.
- Other minor features such as sipes, small lateral extensions to the circumferential grooves and minor lateral grooving on the shoulders.

**Minimum tread depths for passenger vehicles constructed or adapted to carry more than 8 seated passengers**

Minimum tread depth	1mm, excluding any tie bar or tread wear indicator
Position of minimum tread depth band	Form a continuous band covering at least any <b>3/4</b> of the breadth of the tread around the entire circumference

The following diagrams show acceptable positions of the minimum tread depth band, for the vehicles shown in the table above, which must be measured at right angles to the axis of the wheel. Figures 1-4 show cambered wear and Figure 5 shows more detail of how the tread band is measured.

Figure 6 shows that for certain cross-country tyres that may be necessary to accept that the band of acceptable tread pattern may include a plain portion in the centre.

Figures (1), (2), (3) and (4) T= Breadth of Tread  
 $\frac{3}{4} T$  = Minimum width of continuous band.

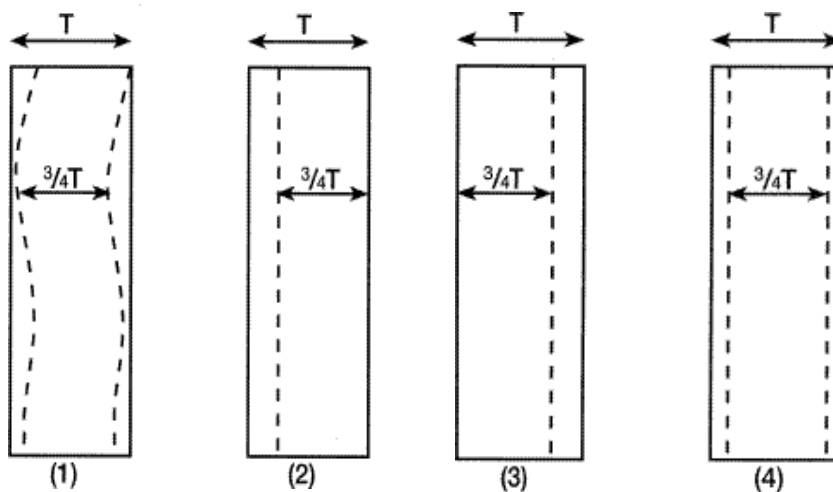

08 Condition of Tyres

Fig (5)

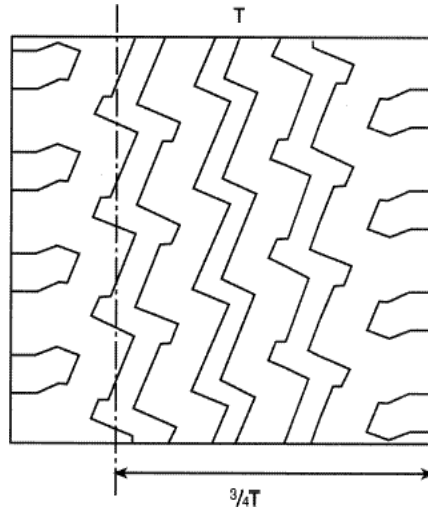

In this case the lateral grooves are the same depth as the circumferential groove and are included in the  $\frac{3}{4}$  measurement.

The breadth of the tread is 'T'.

The  $\frac{3}{4}$  of 'T' measurement can be taken over 'T' as in figure 1 to 4.

Fig (6)

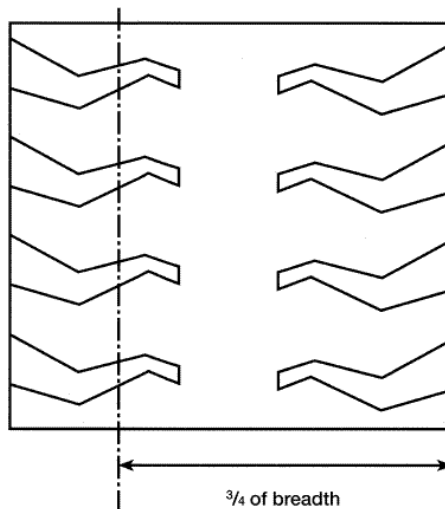

This tyre only has lateral grooving

The band of acceptable tread pattern includes the plain portion which existed when the tyre wall was new. The remaining tread area should contain grooves to the depth of 1 mm.

**If any tread wear indicator is level with corresponding tread**, measure tread depth before deciding if the tread is below the acceptable limit.

## 08 Condition of Tyres

## Tyre Age Markings

All tyres must be marked with the date of manufacture, this is represented by a four-digit code. The first and second digits represent the week of manufacture, the third and fourth digits represent the year.

For tyres manufactured before 01 January 2000, the date may be indicated by a three-digit code. The first and second digits represent the week of manufacture, the third digit represents the year, these will be in-excess of 10 years old.

The date code is only required to be marked on one sidewall and can usually be found at the end of the DOT (Department of Transportation) marking on original manufactured tyres. Retread or recapped tyres may be marked with two date codes, the original manufacture date, and the date of remanufacture, the most recent date must be used when assessing tyre age.

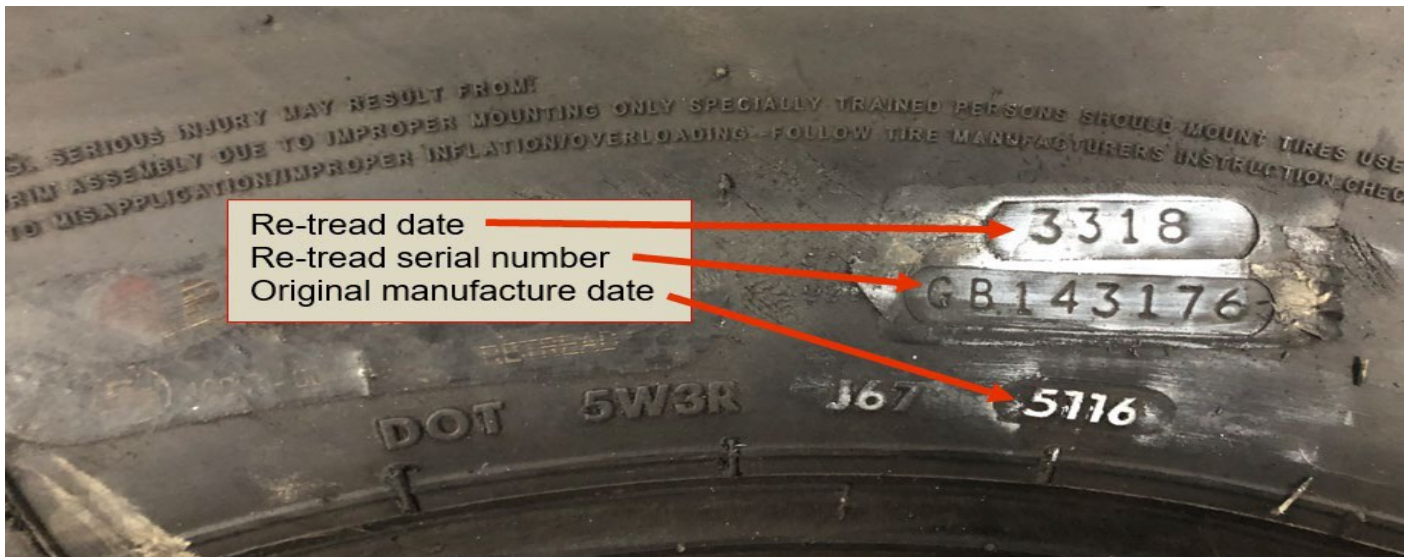

Tyres not displaying a date code would normally be a deficiency. However, date codes are only required to be marked on one side of the tyre so it may not be possible to see the date code on some twin wheel fitments. Under these circumstances you should assume the date code is present and the tyre age is acceptable.

If the date code shows the tyre age to be over 10 years old this will be a deficiency:

**Example:** Date of Vehicle examination 01 February 2021 which is week 06 (**0621**).

- A tyre marked **0611** will pass as it is not more than 10-years old.
- A tyre marked with the date code **0511** (or older) will be a deficiency as it is more than 10-years old.

When assessing tyre age, front steered axles are those deemed to be forward of the chassis midpoint and directly controlled by the vehicle steering system.

Presenters should be advised if any tyres fitted are between 9 and 10 years of age.

# Public Service Vehicle Inspection Manual

## 08 Condition of Tyres

Deficiency	Deficiency Category
<p>1            <b>A tyre:</b></p> <p>a.            with a cut which is deep enough to reach the ply or cords, and is more than 25mm long, or 10% of the section width, whichever is greater.</p> <p>b.            with a lump, bulge or tear caused by separation or partial failure of its structure, including any lifting of the tread rubber.</p> <p>c.            with exposed ply or cord.</p> <p>d.            (i) rubbing on any part of the vehicle.</p> <p>              (ii) fouling on any part of the vehicle and safe driving not impaired.</p> <p>              (iii) fouling on any part of the vehicle and safe driving is impaired.</p> <p>e.            incorrectly seated on its wheel.</p> <p>f.            obviously underinflated.</p> <p>g.            where the base of any groove of the original tread pattern is not clearly visible.</p> <p>h.            where the minimum tread depth and tread band requirements are not met.</p> <p>i.            in excess of ten years of age fitted to any front steered axle or any axle on a minibus with a single wheel fitment.</p> <p>j.            with a date of manufacture code illegible or not displayed:</p> <p>              (i) on any axle (excluding a front steered axle or any axle on a minibus with single wheel fitment).</p> <p>              (ii) to any front steered axle or any axle on a minibus with single wheel fitment.</p>	<p>Major</p> <p>Dangerous</p> <p>Dangerous*</p> <p>Minor</p> <p>Major</p> <p>Dangerous</p> <p>Major</p> <p>Minor</p> <p>Major</p> <p>Dangerous*</p> <p>Dangerous</p> <p>Minor</p> <p>Major</p>
<p>2            <b>A recut tyre</b></p> <p>a.            fitted to a vehicle which should not have one.</p> <p>b.            on which the wholly or partly recut tread pattern is not to the manufacturer's recut tread pattern</p>	<p>Major</p> <p>Major</p>

# Public Service Vehicle Inspection Manual

## 09 Bumper Bars

### Application

This inspection applies to all vehicles.

### Procedure and Standards

**Vehicles are not required to have separate bumper bars**, these may be incorporated with the body in some cases.

### Deficiency

### Deficiency Category

- | Deficiency   | Deficiency Category                      |
|--|--|
| 1  | <b>A bumper bar or bracket which is:</b> |
| a. (i) insecure.   | Major                                    |
| (ii) insecure to the extent that detachment is imminent.   | Dangerous                                |
| b. has a jagged or projecting edge likely to cause injury. | Major                                    |

# Public Service Vehicle Inspection Manual

## 10 Spare Wheel & Carrier

### Application

This inspection applies to all vehicles fitted with a spare wheel or carrier.

### Procedure and Standards

Check the spare wheel for positioning and security.

Check the spare wheel carrier for positioning, condition and security.

### Deficiency

### Deficiency Category

1

#### A spare wheel carrier:

- |       |  |            |
|-------|--|------------|
| (i)   | not in proper condition.   | Minor      |
| (ii)  | insecure, damaged or incorrectly positioned but not so that either is likely to fall from the vehicle. | Major      |
| (iii) | so insecure, damaged or positioned that either is likely to fall from the vehicle.                     | Dangerous* |

2

#### A spare wheel:

- |      |   |            |
|------|---|------------|
| (i)  | insecure or incorrectly positioned but not so that it is likely to fall from the vehicle.   | Major      |
| (ii) | so insecure or positioned that it is likely to fall from the vehicle or cause damage to the electrical wiring, other vehicle components or passenger luggage, or is likely to injure occupants. | Dangerous* |



# Public Service Vehicle Inspection Manual

## 11 Vehicle to Trailer Coupling

	b.	so damaged or deteriorated that injury to passengers or other persons is likely.	Dangerous*
3		<b>Turntable floor:</b>	
	a.	(i) insecure.	Major
		(ii) insecure to such an extent that detachment is likely.	Dangerous*
	b.	covering in such a condition that it could cause slipping or tripping.	Major
		<b>Buses fitted with a trailer coupling</b>	
4		<b>A drawing hitch, bar, hook, eye, ball or ball socket:</b>	
	a.	(i) excessively worn.	Major
		(ii) excessively worn with obvious risk of detachment.	Dangerous*
	b.	(i) seriously deformed or modified impairing its effectiveness and or weakens the component (no trailer attached).	Major
		(ii) seriously deformed or modified impairing its effectiveness and or weakens the component (trailer attached).	Dangerous*
	c.	(i) cracked or fractured (no trailer attached).	Major
		(ii) cracked or fractured (trailer attached).	Dangerous*
	d.	(i) insecure.	Major
		(ii) is insecure to such an extent that detachment is likely.	Dangerous*
	e.	has a missing, damaged, inoperative and or inadequate safety or locking device or any coupling indicator inoperative.	Major
5	(i)	Any mechanical coupling or towing device with an unsafe modification to it secondary parts.	Major
	(ii)	Any mechanical coupling or towing device with an unsafe modification to it primary parts.	Dangerous*

# Public Service Vehicle Inspection Manual

## 14 Wings and Wheel Arches

### Application

This inspection applies to all vehicles.

### Procedure and Standards

Road wheels must have associated with them equipment or part of the body which, as far as practicable, catches mud or water thrown up by the wheels.

If a mudflap is an extension to a wing or similar fitting, a missing or damaged mud flap **is not** a deficiency.

### Deficiency

### Deficiency Category

- | Deficiency  | Deficiency Category          |
|---|------------------------------|
| <b>1</b>  | <b>A Wing or Wheel Arch:</b> |
| a. (i) missing or so badly corroded or distorted to stop it acting as an adequate shield.           | Major                        |
| (ii) so badly corroded or distorted or so insecure that it can fall off or rub on the tyre.         | Major                        |
| b. that has sharp edges that are likely to cause injury.  | Major                        |
| c. which is rubbing on a tyre.  | Major                        |
| d. which does not cover the whole width of a tyre when the wheel is in the straight ahead position. | Major                        |

**Public Service Vehicle Inspection Manual**  
**16 Passenger Doors, Driver Doors and Emergency Exits**

**Application**

This inspection applies to all vehicles and includes:

- all drivers and passenger doors including “continental doors” (for use when coaches are driven on the right hand side of the road).
- all emergency exits including crew emergency exits where there is separate crew accommodation.

**Procedure and standards**

**On Bus Directive and ECE Regulation vehicles there may not be a primary emergency exit** if the vehicle has two service doors and on Bus Directive vehicles the primary emergency exit may be power operated. Floor hatches may be used as emergency exits on Bus Directive vehicles.

**For power operated emergency exits** only the driver’s control will close the exit.

**Power operated doors and emergency exits** must be able to be opened from inside and outside the vehicle without the use of tools.

**A driver’s door with one handle missing is acceptable provided** that the door can be opened by the remaining handle(s) from the inside and outside.

**Pneumatic power operated doors should be operated 5 times** to check that they consistently open fully. If on one occasion the doors fail to open to their fullest extent they should be operated a further 5 times and if the doors fail to open fully on one further attempt this is to be considered a deficiency. Ensure that sufficient air is available to allow this check to be carried out correctly.

Whilst carrying out the above, which should be done with the engine switched off, check, by observing the air gauges, that the continued operation of air operated doors does not deplete the braking system.

**In general safety systems for preventing a passenger from being trapped are required on:**

- All schedule 6 minibuses.
- Doors more than 500mm to the rear of the drivers seat on post 1 October 1990 vehicles (other than minibuses). These doors must re-open.
- On any power operated doors without a soft rubber edge large enough to prevent passengers from being trapped.

**Note.** General safety systems do not apply in respect of power operated Emergency Doors.

**For vehicles that require a door safety system** check the system operates, the door should stop or stop and reopen. For annual tests, a DVSA supplied tool (150mm diameter) will be used to assess this.

**Note.** Power operated doors may not stop or reopen if they are almost closed.

**Where sliding doors are fitted** the condition of runners, tracks and catches should be checked in both the “open” and “closed” positions.

**There is no requirement for the means of operation for a break glass window** to be shown on the outside of the bus.

16 Passenger Doors, Driver Doors and Emergency Exits

**There is no requirement to mark the exterior of a continental door** where an alternative seating plan renders it inaccessible.

Check that if an all over advert or film (e.g. tint/vandal film) has been fitted over a break glass emergency exit, that a gap exists between the advert/film and the window frame or bonding surface and that no mandatory markings are obscured or no longer contrast with background. Where no gap exists or the gap is not between the advert/film and the bonding/frame this will be a deficiency under 1i.

**Door or emergency exit “open” warning devices must be fitted to:**

- Schedule 6 minibuses which do not have two stage slam locks.
- Buses with more than 20 passenger seats which are certified for one person operation and used on local services. A warning device must be fitted to each emergency door and hinged emergency window which is outside the driver’s direct line of sight.
- Any external door or hinged exit (including any emergency exit) which is outside the driver's direct line of sight on a vehicle certified on or after 1 January 1997. This does not apply to a door of a minibus if that door is fitted with a two stage lock. This does not apply to Bus Directive and ECE Regulation Vehicles.
- “Continental doors”.
- On any power operated door fitted more than 500mm behind the driver’s seat on a vehicle registered after 1 October 1990. This must be a visual device.
- On any emergency door or floor hatch on a Bus Directive or ECE regulation vehicle. This must be an audible device.
- On any hinged emergency window which is not clearly visible to the driver on a Bus Directive or ECE regulation vehicle. This must be an audible device.
- On any emergency control for a power operated door fitted to a Bus Directive or ECE Regulation vehicle. This must be a visual and audible Device.
- Service Doors on Bus Directive and ECE Regulation vehicles.
- Automatically operated service doors on Bus Directive and ECE regulation vehicles.

**The function of activating or deactivating may be done by either** operating the door control switches or by an independent switch.

**Break glass hammers enclosed behind glass** do not require the glass shot blasted. The requirement is that the glass is easily broken, however, if the glass is shot blasted this area should be on the inside of the glass (deficiency 6).

16 Passenger Doors, Driver Doors and Emergency Exits

**Tethered break glass hammers are required to** clear the minimum size for an emergency exit. This size is 91cm x 53cm for a secondary exit and 70cm x 50cm with a minimum area of 4,000sq cm for an additional exit. For Bus Directive and ECE Regulation vehicles, this size is 60cm x 40cm with corners radiused to 20cm, for emergency windows in the rear face of the vehicle, this size can alternatively be 140cm x 35cm with corners radiused by 17.5cm. If this is not possible this is a deficiency (1b).

**The exact wording/pictogram used for exit markings may vary** but variations are acceptable as long as it is clear that it is an emergency exit and the means of operation are present.

**The minimum requirements for an emergency door, window or roof hatch are:**

1. Primary or Secondary exit:
  - i) the emergency exit shall be clearly marked as such inside and outside the vehicle.
  - ii) the means of operation of the doors and hinged windows fitted to the emergency exit shall be clearly indicated.
2. Additional emergency exit situated in either the front, rear face or the roof:  
be clearly marked as an emergency exit:
  - iii) on the inside of the vehicle, and
  - iv) in a case where the emergency exit can be opened from the outside, must be marked on the outside of the vehicle.
  - v) be clearly marked with its means of operation.
3. For Bus Directive and ECE Regulation vehicles, emergency exit/s may be a window, door or hatch, the minimum requirements are:
  - vi) All emergency exit/s must be marked on the inside and outside of the vehicle with the inscription 'Emergency Exit' or similar.
  - vii) All emergency control/s of emergency exit/s must be marked with the method of operation.

**Public Service Vehicle Inspection Manual**  
**16 Passenger Doors, Driver Doors and Emergency Exits**

<b>Deficiency</b>	<b>Deficiency Category</b>
<p><b>1                    A door or emergency exit:</b></p> <p>a.            incomplete or missing.</p> <p>b.            cannot be opened to its fullest extent.</p> <p>c.    (i)    with a sliding action which will not remain closed or is likely to fly open inadvertently or will not open without undue effort.</p> <p>              (ii)    with a hinged action which will not remain closed or is likely to fly open inadvertently.</p> <p>d.            with a missing/defective device for holding a door, or on a Bus Directive or ECE vehicle, a door or top hinged emergency window, open.</p> <p>e.    (i)    with insecure, excessively worn or fractured hinges or pins, or with insecure door pillars, which could adversely affect operation.</p> <p>              (ii)    with insecure, excessively worn or fractured hinges or pins, or with insecure door pillars, which could adversely affect operation and is likely to cause an injury.</p> <p>f.            with a supplementary locking device which cannot be overridden by all of the associated interior door controls.</p> <p>g.            with a release handle guard insecure or missing.</p> <p>h.            “open” warning device missing or inoperative.</p> <p>i.            a break glass window fitted with laminated glass or other unbreakable glazing.</p>	<p>Major</p> <p>Major</p> <p>Major</p> <p>Dangerous</p> <p>Major</p> <p>Minor</p> <p>Major</p> <p>Major</p> <p>Major</p> <p>Major</p>
<p><b>2                    A door or emergency exit opening or closing mechanism:</b></p> <p>a.            defective, excessively worn or damaged so that it is difficult to open or close the door or exit.</p> <p>b.            control button(s) loose, sticking or with excessive movement before operating.</p>	<p>Major</p> <p>Major</p>

**Public Service Vehicle Inspection Manual**  
**16 Passenger Doors, Driver Doors and Emergency Exits**

<b>Deficiency</b>	<b>Deficiency Category</b>
3	<b>A door and emergency exit marking:</b>
a.	missing. Major
b.	method of operation not shown (not applicable to Schedule 6 apart from the emergency door). Major
4	<b>Power operated doors and emergency exits:</b>
a.	repeated operations of the doors depletes the braking system(s) pressure below the level at which the circuit protection valve should operate. Major
b.	cannot be opened from inside or outside the vehicle using the emergency controls. Major
c.	soft edge missing, deteriorated or damaged so that injury could be caused to any person. Major
d.	safety system does not operate correctly. Major
5	Plug door opens or closes suddenly or with excessive force and is likely to injure persons outside the vehicle. Major
6	Emergency exits with an opening tool or device missing or not secured in a readily accessible place. Major
7	Driver cannot activate or deactivate the operation of an automatically operated service door. Major

# Public Service Vehicle Inspection Manual

## 17 Drivers Accommodation

### Application

This inspection applies to all vehicles.

### Procedure and Standards

Examine the cab floor, internal wheel arches and cab steps for condition and security.

A driver escape window is required for vehicles with a separate and enclosed driver compartment, where the driver's seat is only accessible from the offside (the escape window must be fitted elsewhere than the offside).

Deficiency	Deficiency Category
<p>1                    <b>A cab floor or internal wheel arch in the driver's area which:</b></p> <p>(i)    is badly deteriorated or insecure.</p> <p>(ii)   is so badly deteriorated or insecure it is likely to impair the driver's control of the vehicle or is likely to cause injury.</p>	<p>Major</p> <p>Dangerous*</p>
<p>2                    <b>Step, step ring or grab handle:</b></p> <p>(i)    insecure.</p> <p>(ii)   which is so insecure or in such a condition it is likely to cause injury.</p>	<p>Minor</p> <p>Major</p>
<p>3                    <b>Driver's escape window:</b></p> <p>a.       not provided.</p> <p>b.       cannot be opened.</p>	<p>Major</p> <p>Major</p>

# Public Service Vehicle Inspection Manual

## 18 Driver's Seat

### Application

This inspection applies to all vehicles and only relates to the **driver's seat**.

### Procedure and Standards

**When checking the driver's seat adjustment** it is not necessary to check that the seat can be secured in all possible positions.

**In the case of electrically adjusted seats**, it is not necessary to check any 'memory position' function.

### Deficiency

### Deficiency Category

1	<b>A driver's seat:</b>	
	(i) structure defective.	Major
	(ii) so insecure or in such a condition that it could cause the driver to lose control of the vehicle.	Dangerous*
2	The driver's seat fore and aft adjustment mechanism not functioning as intended.	Major

**Application**

This inspection applies to all vehicles.

**Procedure and Standards**

**Security of Body**

The inspection covers:

- all fixings (e.g. brackets) securing the body to the chassis or to a sub-frame or supporting members.
- fastenings e.g. securing bolts, rivets or welds for the fixings.
- structural (stressed) panels.

**Defective fastenings do not necessarily mean that the body is insecure.** The whole structure must be assessed and deficiencies will only be justified where sufficient bolts, rivets and welds etc. are loose or defective to allow the body to move enough to cause a hazard for other road users.

**Some designs of body mounting allow a limited amount of flexing** between the body and chassis. This must not be confused with insecurity.

**Coach bolt failure due to corrosion may not be obvious** as the failed section may be in a position where it cannot be seen. Care should be taken to check with this type of fixing that there is no sign of abnormal movement of the structure which would indicate coach bolt failure.

**Check the condition of the load bearing body members for** corrosion, cracks or damage which could seriously weaken their strength.

**Deficiency**

**Deficiency Category**

1	<b>Body:</b>	
	a. excessively displaced relative to the chassis.	Major
	b. (i) insecure.	Major
	(ii) insecure with stability affected	Dangerous
2	<b>A load bearing member so cracked, corroded or damaged that the body is:</b>	
	(i) seriously weakened.	Major
	(ii) seriously weakened and vehicle stability is impaired.	Dangerous

**Public Service Vehicle Inspection Manual**  
**20 Exterior of Body including Luggage Compartments**

<b>Application</b>		
This inspection applies to all vehicles.		
<b>Procedure and Standards</b>		
Check for defective items, which would make the vehicle dangerous to other road users or pedestrians. The cumulative effect of any defects found must be considered or their influence on other items. Superficial damage which does not affect the strength of a component or which does not pose a danger to other road users is not a deficiency.		
<b>Deficiency</b>	<b>Deficiency Category</b>	
1	<b>Body panels, frame members, fittings or components:</b>	
a.	(i) insecure, fractured or cracked, distorted, worn, corroded, damaged or modified, to such an extent it is likely to cause injury.	Major
	(ii) insecure, fractured or cracked, distorted, worn, corroded, damaged or modified to such an extent the vehicle is obviously dangerous to other road users, passengers or pedestrians.	Dangerous
b.	(i) with an inappropriate modification of the bodywork.	Major
	(ii) with an unsafe modification of the bodywork which has seriously weakened the component.	Dangerous
2	<b>Luggage compartment:</b>	
a.	structure defective allowing contents to protrude or fall onto a road, or in a condition to damage or soil luggage.	Major
b.	access doors likely to become detached.	Dangerous*
c.	(i) access doors with a sliding action which will not remain closed or is likely to fly open inadvertently.	Major
	(ii) access doors with a hinged action which will not remain closed or is likely to fly open inadvertently.	Dangerous
d.	which when secured in the open position obscures a position lamp, direction indicator or rear retro reflector.	Major

# Public Service Vehicle Inspection Manual

## 21 Interior of Body, Passenger Entrances, Exit Steps and Platforms

### Application

This inspection applies to all vehicles.

### Procedure and Standards

**Buses which have an accessibility certificate or a DDA special authorisation** will have wheelchair facilities and disabled access examined under IM 24 (does not apply to PSVs with 22 or fewer passengers).

**Manual retractable steps on Bus Directive and ECE Regulation vehicles must be fitted with an audible warning** to indicate that the steps have not been fully retracted into the travelling position. Power operated steps on these vehicles must have an interlock to prevent the vehicle being driven with the steps in the down position.

**Crew seats should be marked “for crew use only” or similar.** On Bus Directive and ECE Regulation vehicles the seat only needs to be identified for crew use and the wording is not specified.

**Removal of a parcel rack from a vehicle will not be a deficiency unless** a communication control or grab rail is an integral part of the parcel rack, and there are not sufficient alternatives to these items.

**Failure of forced air ventilation will only be a deficiency if** more than 50% of the system is ineffective. Alternatively, if there are adequate side opening windows or roof vents, failure, or partial failure of the forced ventilation system will not be a deficiency. The requirement for ventilation does not apply to Schedule 6 minibuses, or to the toilet compartment on any vehicle.

**Audible and visual devices to request the driver to stop** are not required on buses with less than 13 passenger seats or Schedule 6 minibuses. If a visual and an audible system are fitted only one needs to operate, so long as it operates throughout the vehicle.

**Bus Directive and ECE regulation vehicles which do not have provision for standing passengers** do not require a communication device. All Bus Directive and ECE regulation vehicles which carry standing passengers must have at least one illuminated sign (on each floor or articulated section which may be text or a pictogram to indicate to passengers that the bus is stopping).

**Some early vehicles were fitted with muted bells,** these vehicles should not be failed at annual test (Muted bells only work once until they are reset).

**If the first aid kit receptacle is in a sealed compartment or closed glove box;** the compartment or glove box should be clearly marked to indicate the position of the first aid kit. If the first aid kit is behind a glass panel the panel should not be removed for this inspection. If a break glass panel is fitted the shot blasted area should face inward to allow the glass to be easily broken. If it is facing outward this will be a deficiency.

**An empty first aid box** will be considered as missing.

**First aid kits are required for all large buses** (apart from those used on local services) and on Schedule 6 Minibuses. There is no requirement to inspect the contents of a first aid kit.

21 Interior of Body, Passenger Entrances, Exit Steps and Platforms

**If a large bus used on local services is presented for test with markings showing the presence of a first aid kit** but no kit is carried this will be a deficiency unless the sign is removed or covered.

**At least one fire extinguisher must contain water or foam** and be marked BS 5423, BS EN3 or EN3 and have a minimum fire rating of at least 8A or 21B. A fire extinguisher must be maintained in good efficient working order. Where a gauge on a fire extinguisher can be seen and indicates the fire extinguisher is discharged, this will be a deficiency.

**If the extinguisher is behind a glass panel the panel should not be removed** for this inspection. A glass panel with a shot blasted area is only readily breakable if the shot blasted surface faces inwards (i.e. towards the fire extinguisher). If a shot blasted area faces outwards this is a deficiency. If the glass has been shot blasted in accordance with the above paragraph, then no other device for breaking the glass is required.

**Other acceptable means of gaining access to fire extinguishers or first aid kits covered by a glass panel**, that we are currently aware of, are:

- A ring pull which allows the easy removal of the glazing panel, or
- Toughened glass with a break glass hammer provided.

**There may be other acceptable methods** which have been approved by certifying officers.

**There is no requirement to check for safety markings on the glass covers** of a first aid and fire extinguisher.

**There are no requirements with regards to the height** at which the fire extinguisher is placed.

**Examine all “other facilities”** If any “other facility” is clearly inoperative and is not causing any danger to passengers this is not a deficiency. Those most likely to be seen are:

- Wheelchair lifts and ramps (if fitted to a bus with an accessibility certificate or a special authorisation, examine under Inspection Manual item 24).
- Wheelchair fixings and features (if fitted to a bus with an accessibility certificate or a special authorisation examine under Inspection Manual item 24).
- Combustion heaters.
- Cookers/refrigerators.
- Drinks dispensers.
- Televisions/video monitors.

## Public Service Vehicle Inspection Manual

### 21 Interior of Body, Passenger Entrances, Exit Steps and Platforms

**When inspecting separately fuelled appliances such as combustion heaters or cookers** any signs of scorching charring or melting will be a deficiency.

**If a vehicle is presented with a different seating arrangement** to that on the technical print (either more seats or less). This is not a reason for refusal to test but may be a deficiency if the seating arrangements endanger passengers deficiency 3b. Issue a VTP 57 and give the operator a VTP5, inform enforcement of the failure to comply with regulations.

**Public Service Vehicle Inspection Manual**

**21 Interior of Body, Passenger Entrances, Exit Steps and Platforms**

<b>Deficiency</b>		<b>Deficiency Category</b>
1	<b>Body Interior:</b>	
	a. access to any exit obstructed.	Major
	b. steps and stairways, retractable steps, floors, platforms or floor traps:	
	(i) in a deteriorated condition.	Minor
	(ii) damaged or insecure but unlikely to collapse in normal use.	Major
	(iii) so damaged or insecure or in such a condition that they are likely to collapse in normal use.	Dangerous*
	c. a floor trap locking device worn or ineffective so that the trap may become displaced.	Dangerous*
2	<b>Retractable steps with:</b>	
	a. a step which will not retract or remain retracted.	Major
	b. a step which will not operate or operates incorrectly.	Major
	c. driver able to move vehicle without being aware that the step is in the down position e.g. direct sight, mirror, warning device or interlock.	Major
	d. driver able to move vehicle without being given an audible warning when a manually operated step is not fully retracted on Bus Directive and ECE regulation vehicles.	Major
	e. driver able to move vehicle when a power operated step is in the down position on Bus Directive and ECE regulation vehicles, without an effective safety device to prevent the power operated steps from operating with the vehicle in motion.	Major
	f. a step insecure.	Major
	g. non-slip material defective.	Major
3	<b>A seat:</b>	
	a. insecure, damaged or weakened so that the damaged seat structure or covering could endanger passengers or damage their clothing.	Major

## Public Service Vehicle Inspection Manual

### 21 Interior of Body, Passenger Entrances, Exit Steps and Platforms

	b.	layout which has been changed without approval and which could endanger passengers.	Major
	c.	with covering(s) in such a condition that they are likely to soil passengers clothing.	Minor
	d.	(i) number reduced from the approved number.	Minor
		(ii) number increased from the approved number.	Major
4		<b>Crew Seats:</b>	
	a.	which encroach into gangways or exits and do not automatically retract when not in use.	Major
	b.	without a legible notice saying “ <b>for crew use only</b> ” or similar on or adjacent to the seat or not identified as for crew use on a Bus Directive and ECE regulation vehicle.	Major
5	(i)	grab rails, straps, stanchions, guard rails and barriers, missing or insecure and not likely to endanger passengers.	Minor
	(ii)	grab rails, straps, stanchions, guard rails and barriers so insecure and in such a condition they are likely to endanger passengers.	Major
6		Parcel racks in such a condition that allows articles to fall onto the driver or passengers.	Dangerous*
7		<b>Ventilation:</b>	
	a.	forced ventilation equipment ineffective (not Schedule 6 minibuses).	Major
	b.	any ventilator, opening windows or roof hatches insecure.	Major
	c.	more than 50% of the ventilator system (i.e. opening windows, ventilators and roof hatches) inoperative where forced air ventilation is not available.	Major
8		engine interior covers missing, contaminated to a degree which constitutes a fire risk, or which allows fumes to penetrate passenger saloon.	Major

## Public Service Vehicle Inspection Manual

### 21 Interior of Body, Passenger Entrances, Exit Steps and Platforms

9	<b>Interior lighting with:</b>	
	(i) inadequate illumination of saloon interior, steps, platform, staircase and other facilities (interior lights only apply to steps for Schedule 6 minibuses).	Minor
	(ii) completely inoperative lamp(s) for illumination of saloon interior, steps, platform, staircase and other facilities (interior lights only apply to steps for Schedule 6 minibuses).	Major
10	<b>Passenger Communication with driver:</b>	
	a. missing or inoperative.	Major
	b. does not give a visual indication to passengers that the bus is stopping on Bus Directive and ECE regulation vehicles which carry standing passengers.	Major
11	<b>Interior surfaces:</b>	
	a. insecure or damaged so that it is likely to cause injury to passengers.	Major
	b. contaminated so that they are likely to soil passengers clothing.	Minor
12	<b>First Aid Kit:</b>	
	a. missing, inaccessible or in poor or contaminated condition.	Major
	b. receptacle not marked.	Major
13	fire extinguisher missing, inaccessible, discharged, incorrect type or in an obviously poor condition.	Major
14	any "other facility" (including those listed in 15-19 below) which is incomplete, insecure and/or incorrect function and is likely to endanger passengers.	Major

## Public Service Vehicle Inspection Manual

### 21 Interior of Body, Passenger Entrances, Exit Steps and Platforms

15	<b>Wheelchair lifts/ramps:</b>	
a.	the strength of the lift or ramp is significantly impaired.	Major
b.	there are sharp edges or other protrusions on a lift or ramp which are likely to cause injury.	Major
c.	(i) defective in operation and not likely to injure passengers, pedestrians or other road users.	Minor
	(ii) defective in operation to the extent that it is likely to injure passengers, pedestrians or other road users	Major
d.	(i) non-slip surface on ramp defective.	Minor
	(ii) non-slip surface on ramp defective to such an extent that it is likely to cause injuries.	Major
e.	a lift or ramp which cannot be secured in stored position.	Major
16	<b>Wheelchair spaces:</b>	
a.	any wheelchair floor fitting loose or likely to cause passengers to trip.	Major
b.	any padded backrest missing (when known to be an original fitting), insecure or in a condition which is likely to cause injury to passengers.	Major
c.	any stanchion, retractable rail/movable device, partition or panel relating to the wheelchair area missing, insecure or in a condition which is likely to cause injury to passengers.	Major
17	combustion heater with fuel filler inside vehicle.	Major
18	cookers/refrigerators/drinks dispenser in such a condition that they are likely to endanger passengers.	Major
19	television/video for passenger entertainment with the screen placed where driver can view whilst driving.	Major

# Public Service Vehicle Inspection Manual

## 22 Mirrors and Indirect Vision Devices

### Application

This inspection applies to all vehicles and the number and type of mirrors and or indirect vision devices (excluding periscopes) which have to be fitted are shown below.

DATE OF FIRST USE	REQUIREMENTS
Before 1 April 1983	An exterior mirror on the offside and either an interior mirror (unless this would not give a view to the rear) or an exterior mirror on the nearside.
From 1 April 1983	A main exterior mirror on both the offside and the nearside.

### Procedure and Standards

**"Indirect vision device "** means a device to observe the traffic area adjacent to the vehicle which cannot be observed by direct vision. This can be a conventional mirror(s), camera-monitor(s) or other device(s) (but not a periscope) able to present information about the indirect field of vision to the driver.

**"Interior mirror"** means a device as defined in the above paragraph, which can be fitted in the passenger compartment of a vehicle.

**"Exterior mirror"** means a device as defined in the above paragraph, which can be mounted on the external surface of a vehicle.

Deficiency	Deficiency Category
1 Not fitted with the correct number or type(s) of mirror, or other indirect vision device.	Major
2 (i) A required mirror or indirect vision device with minor damage that does not obviously interfere with the view to the rear or nearside of anyone sitting in the driving seats.	Minor
(ii) A required mirror or indirect vision device in such a condition that anyone sitting in the driving seat cannot see clearly towards the rear or nearside.	Major
3 A mirror/indirect vision device or its mounting bracket insecure or structurally deteriorated.	Major
4 A mirror/indirect vision device or periscope insecure and in such a condition that it is likely to injure the driver or passengers.	Major

**Application**

This inspection applies to all vehicles.

**Procedure and standards**

**Zone "A"** is 350mm wide, in the swept area of the screen and centred on the centre of the steering wheel.

**Zone "B"** is the remainder of the swept area.

**Zone "C"** is the remainder of the screen outside the sweep of the wipers.

When checking the windscreen refer to the diagram below.

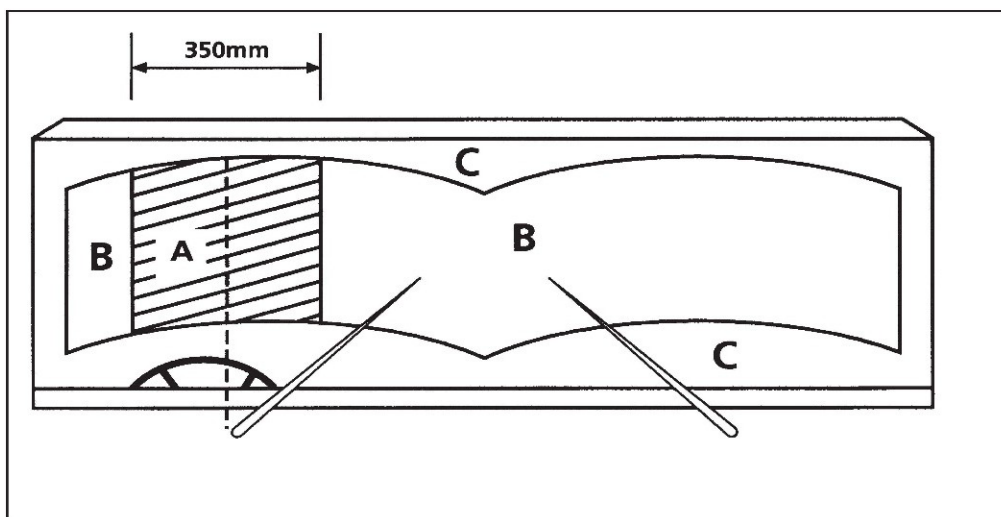

**Windscreen**

Examiners should have regard for the three separate "zones" when assessing damage or discolouration. A greater amount of damage or discolouration could be accepted in zone "C" than in zone "B". Likewise, a greater amount can be accepted in zone "B" than in zone "A" where relatively minor damage may be a deficiency.

**When assessing damage, light surface scratches** are not to be considered as damage. However, an area of concentrated scratches such as those caused by prolonged use of a defective wiper blade which materially affects view to the front, or the sides is to be considered a deficiency.

**Repaired windscreens must be inspected to the same criteria as original** unrepaired screens. Repairs must be judged as to whether they materially affect view to the front or the sides.

## Public Service Vehicle Inspection Manual

### 23 Glass and View of the Road

**“Swept area” means** the area swept by the wipers in their normal operation and does not include any additional area of the screen covered by the wipers to reach the parked position or which the original manufacturer has designed as opaque.

Check that the correct type of glass or safety glazing is fitted to the windows specified in the table below.

VEHICLE FIRST USE	WINDSCREEN	WINDOW AT EITHER SIDE OF THE DRIVER	FORWARD FACING WINDOW OTHER THAN A WINDSCREEN	OTHER WINDOWS	WINDOWS IN INTERNAL PARTITIONS SCREENS AND DOORS
From 1 April 1988	Safety glass	Safety glass	Safety glass or safety glazing	Safety glass or safety glazing	Safety glass or safety glazing
From 1 June 1978	Safety glass	Safety glass	Safety glass or safety glazing	Safety glass or safety glazing	No requirement
From 1 January 1959	Safety glass if glass is fitted	Safety glass if glass is fitted	Safety glass if glass is fitted	Safety Glass if glass is fitted	No requirement
Before 1 January 1959	Safety glass if glass is fitted	No requirement	Safety glass if glass is fitted. The glass fitted to the upper deck of a double decker need not be safety glass.	No requirement	No requirement

**Plastic safety glazing or laminated glass** is not suitable for use in “Break Glass” emergency exits.

Check that all safety glass is properly marked (marking of glass is not required for vehicles first used before 1 June 1978). Acceptable markings include:

- BS857
- BS AU 178
- An “e” mark followed by a number in a square
- BS 5282 (only on vehicles first used before April 1985)
- TP GS or TPGSE (Glass made in France only acceptable on vehicles on vehicles first used before October 1986)
- An “E” mark including the number 43R

**Normally glass marked only with a kite mark and BS6206 is not acceptable**, the glass must be marked with one of the other acceptable markings. In the past some buses were certified where the only marking on the glass was a kite mark. If a bus has glass marked in this way and there is no reason to believe it is not safety glass this is acceptable.

**If an acceptable mark has become faint or deteriorated** this is not a deficiency.

**LDV Convoys front door window glass markings are situated below the trim** and are not visible. This model should not be refused for failure to display an appropriate mark.

**Side windows with a marking of M416 are acceptable**, it is not acceptable for windscreens.

**Where glass is replaced with a piece from a stock sheet** and the repairer has evidence of the standard to which the stock sheet complied, it is acceptable for them to mark the glass with the standard reference number but must be accompanied by a permanent mark which the person/company can identify.

**“Safety glazing”** means material (other than glass) which is so constructed or treated that if fractured it does not fly into fragments likely to cause severe cuts. There is a large range of materials which can be fitted as safety glazing and it is not possible to identify these positively at the test, as there is no requirement for marking.

**Check the view of the road from the driver’s seat. The view** must not be obstructed by any changes to the original design such as the addition of stickers, pennants, cab decorations, stoneguards, dash mounted tables, or other items, which materially affect view to the front or the sides.

**On many vehicles, the original design will place things like instrument panel clusters inside the field of view.** Intrusions such as this which are an original design features can be ignored, as can damage, obstructions or unofficial stickers which are hidden by that feature.

**Many commercial vehicles have very large screens and have windscreen wipers which cover an area** that have no practical use. For the purposes of the annual test, the area of the screen above a horizontal line taken from the driver’s eye position, assessed from the driving seat looking forward in a comfortable upright driving position, can be ignored other than the area through which the driver is required to view any mirror. It is not necessary to speculate on the effects of tall or short drivers.

**Official stickers and acceptable features (see examples below) are permitted to encroach into the field of vision if** this is necessary to comply with other regulations. These will be considered a deficiency only where they **seriously restrict the drivers view** to the front or the sides.

Examples of features which may intrude into the swept area of the wipers provided they do not **seriously restrict the drivers view** to the front or the sides are:

- Vehicle distance or lane indicator systems
- Operator licence
- Automatic windscreen wiper detectors
- Fresnel lens
- Split windscreens
- Wipers which park adjacent to a central pillar
- Driver monitoring systems
- Driver’s aids such as blinds and their mountings
- Toll payment tags/stickers
- vehicle anti-theft scheme stickers/security passes
- Section 19 permits
- Monitors for indirect vision devices

Examples of features which may intrude into the swept area of the wipers provided they do not **materially affect view** to the front or the sides are:

- No smoking signs
- Maximum height signs
- Maintenance information stickers
- Other non-mandatory signs or stickers
- DDA handrails
- Anti-vandal screens and any associated poles
- Dash mounted tables, laptops/tablets/mobile phones/satellite navigation which is not original equipment
- Dash mount monitors/control systems
- Ticket machines and fare collection equipment.

In respect of ticket machines or fare collection equipment, “materially affect” means; a person 107cm tall 30cm wide is not totally concealed by the ticket machine or other fare collection equipment 2m in front of the vehicle.

**Note:** It is important to remember the monitors mounted on a dash will be used for different purposes such as non-original satellite navigation which will be assessed as whether they materially affect view whereas monitors for safety features such as blind spot systems for indirect vision requirements will be assessed as to whether they seriously affect view.

<b>Deficiency</b>		<b>Deficiency Category</b>
1	<b>A windscreen:</b>	
a.	(i) with an obstruction, damage or discolouration which materially affects view to the front or the sides through the area of windscreen not swept by the wipers (zone C).	Minor
	(ii) with an obstruction, damage or discolouration which materially affects view to the front or the sides through the area of windscreen swept by the wipers.	Major
b.	(i) with a crack in the windscreen outside of the area swept by the wipers (zone C).	Minor
	(ii) with a crack passing through the swept area which renders the screen insecure or which materially affects view to the front or the sides through the area of windscreen swept by the wipers.	Major
c.	with any crack where there is noticeable displacement of the surfaces on either side which has an adverse effect on the condition and operation of the windscreen wipers.	Major
d.	with damage which exposes the inner layer of a laminated screen.	Major

# Public Service Vehicle Inspection Manual

## 23 Glass and View of the Road

<b>2</b>	<b>A windscreen or window:</b>	
a.	so insecure that it is likely to fall out or damaged to the extent that it presents a danger to occupants or to other road users.	Dangerous*
b.	with damage or obstruction, which impairs the driver's view of a mandatory mirror.	Major
c.	not made from safety glass or safety glazing as specified.	Major
d.	made of safety glass which does not show an acceptable marking.	Major
e.	in such a condition it would allow water to leak into the passenger areas.	Major
f.	windscreen or outside window missing.	Major
g.	or internal screen or partition so insecure that it is likely to fall out in normal use or cause injury to any person on the vehicle.	Dangerous*
<b>3</b>	A guard rail or barrier at a window, internal screen or partition missing, insecure or damaged to the extent that injury to a passenger is likely.	Major

**Application**

This inspection applies to all vehicles, which have been issued with an Accessibility Certificate or a Special Authorisation. As an alternative to Schedules 1, 2 or 3 some vehicles with accessibility certificates will be Bus Directive vehicles and will include compliance with Annex VII and the route and destination requirements of Schedule 2 or 3. These will have been issued with a Notification Form PSV501. This will have been noted on the technical record for the vehicle.

This section does not apply to PSVs with a carrying capacity of 22 passengers or less.

**Procedure and Standards**

**Restraints**

Wheelchair and wheelchair user restraints may form part of a combined restraint system.

**Padded backrests**

On Annex VII vehicles the backrest need not be padded and, as an alternative to a backrest, a device which acts as a support for the wheels of the wheelchair may be provided.

**Ramp operations**

For operation, the ramp or lift can be deployed or lowered to the surface on which the vehicle is sitting. On an Annex VII vehicle a ramp need not lower to the surface on which the vehicle is sitting but must lower to within 150mm above that surface.

**Bands of contrasting colour**

On an annex VII vehicle this is only required on a powered ramp, and it may be red and white striped or a single band of contrasting colour.

**Stowage systems**

Any means to retain the device in the stowed position can easily be released and if the means requires any form of power, the device can be easily released in the event of a power failure, if necessary, with the use of a tool carried on the vehicle.

**Portable ramps**

Any portable ramp with a positive means to prevent the ramp being easily detached from the vehicle when driven (e.g. locating pins) must comply with the requirement that a vehicle cannot be driven normally unless the lift or ramp is at its normal position for vehicle travel. Portable ramps without this positive means to prevent easy detachment do not have to meet this requirement.

**Power operated lifts and ramps**

- When checking for correct operation, this includes all internal and external controls relating to the operation or stopping of the lift or ramp. Where controls are available adjacent to the lift or ramp check that controls that initiate operation can be isolated by a control in the driver's cab.
- If there is more than one lift or ramp only one need to operate manually.
- In the case of a lift, once stopped it must be capable of being reversed. Safety devices are not required for a ramp if the force of the ramp is unlikely to cause injury or a lift if the operating control is adjacent to the lift.

24 Accessibility Features

**Entrance and exits**

Where fitted with a power operated lift or ramp that is not within the driver's direct field of vision, and where the operating control is not adjacent to the lift or ramp. The driver when seated in the driver's seat must have a clear unobstructed view of the inside and outside of the door area in which the lift or ramp operates either through mirrors or another optical device such as CCTV or optical cable.

**Signs and markings**

For each wheelchair space there must be a sign or instruction indicating the direction a wheelchair and user should face during travel. In the case of an Annex VII vehicle a sign need not indicate the direction that a wheelchair should face. There must be safety instructions explaining the use of the wheelchair space including any wheelchair restraint system and wheelchair occupant restraint system. This does not apply to Annex VII vehicles.

**Lighting**

The operation of accessibility lighting may be operated by the general interior lighting control(s), separate control(s) or automatically by opening the doors.

**Steps**

In the case of a step which projects beyond the body of the vehicle and is likely to injure pedestrians, check that the step can fold or retract and the vehicle is not capable of being driven normally unless the step is folded or retracted. In the case of Annex VII vehicles this last requirement is only for vehicles fitted with power operated steps.

In the case of a power operated step, the step must be incapable of being operated with the vehicle in motion and any malfunction of any safety device, which stops the motion of the step to prevent injury is a deficiency. Safety devices are not required if the force of the step is unlikely to cause injury.

**The communication device with the driver in the wheelchair space can be audible or visual.**

**If there is reason to believe a vehicle has had accessibility features changed or removed since being approved, please report it centrally using the VTP57 system.**

# Public Service Vehicle Inspection Manual

## 24 Accessibility Features

Deficiency	Deficiency Category
<p>1            <b>Wheelchair spaces:</b></p> <p>a. (i) any wheelchair restraint components deteriorated, insecure or defective but not likely to affect its function.</p> <p>          (ii) any wheelchair restraint components missing, or badly deteriorated, insecure and or defective to such an extent the function is obviously affected.</p> <p>b. (i) any wheelchair user restraint components deteriorated, insecure or defective but not likely to affect its function.</p> <p>          (ii) any wheelchair user restraint components missing, or badly deteriorated, insecure and or defective to such an extent the function is obviously affected.</p>	<p>Minor</p> <p>Major</p> <p>Minor</p> <p>Major</p>
<p>2            <b>For each wheelchair space designed for a rearward facing wheelchair:</b></p> <p>a. any padded backrest missing, insecure or in a condition which is likely to cause injury to passengers (see note).</p> <p>b. any stanchion, fixed rail, retractable/movable device, partition or panel relating to the wheelchair area missing, insecure or in a condition which is likely to cause injury to passengers.</p>	<p>Major</p> <p>Major</p>
<p>3            <b>Boarding lifts and boarding ramps:</b></p> <p>a. a lift or ramp missing, insecure or the strength of the lift or ramp is significantly impaired.</p> <p>b. a lift or ramp which does not function as intended or does not operate through the required range of movement.</p> <p>c. there are sharp edges or other protrusions on a lift or ramp which are likely to cause injury.</p> <p>d. the band of contrasting colour on a lift or ramp surface edge is missing or has deteriorated to the extent that it is visually ineffective.</p> <p>e. a lift surface does not have an effective device for preventing wheelchairs from rolling off or the device is ineffective.</p>	<p>Major</p> <p>Major</p> <p>Major</p> <p>Minor</p> <p>Major</p>

# Public Service Vehicle Inspection Manual

## 24 Accessibility Features

	f.	(i) cannot be stowed, failure or malfunction of any stowage retaining device (including failure to release without power supplied where appropriate) but safety not affected.	Minor
		(ii) cannot be safely stowed, failure or malfunction of any stowage retaining device (including failure to release without power supplied where appropriate) that affects safety.	Major
	g.	the safety device intended to prevent the vehicle being driven normally when the lift or ramp is not in its intended position for vehicle travel is ineffective.	Major
4		<b>A power operated lift or ramp (additional requirements):</b>	
	a.	defective in operation to the extent that it is likely to injure passengers, pedestrians or other road users.	Major
	b.	with an audible device missing or inoperative (except an Annex VII vehicle with a powered lift).	Major
	c.	(i) on an Annex VII vehicle with a powered ramp the yellow warning lights are defective.	Minor
		(ii) on an Annex VII vehicle with a powered ramp the yellow warning lights are missing.	Major
	d.	incapable of being operated manually and the vehicle does not have a portable ramp.	Minor
	e.	without an effective safety device to prevent the lift or ramp from operating with the vehicle in motion.	Major
	f.	safety device to stop the extension or retraction of a ramp or lift on meeting an obstruction inoperative and is likely to cause injury.	Major
5		Portable ramp (additional requirements) with no suitable storage stowage position and likely to cause injury to any passenger or crew.	Major
6		<b>Entrance and exit optical device to allow driver to view wheelchair entrances and exits:</b>	
	a.	missing or ineffective.	Major
	b.	(i) insecure but unlikely to become detached.	Major
		(ii) insecure to such an extent that detachment is imminent.	Dangerous*

**Public Service Vehicle Inspection Manual**  
**24 Accessibility Features**

7	A required sign/markings or safety instruction missing or illegible.	Minor
8	<b>Communication devices:</b>	
	a. any internal wheelchair space communication device missing or inoperative.	Major
	b. any external communication device missing or inoperative.	Major
9	Lighting specifically intended for wheelchair users to board or alight in safety; missing, inoperative or deteriorated to the extent that the illumination is significantly reduced (see note).	Major
10	Floors and gangways slip resistant material deteriorated to the extent that it is no longer effective.	Major
11	<b>Steps with:</b>	
	a. slip resistant material deteriorated to the extent that it is no longer effective.	Major
	b. band of contrasting colour is missing or deteriorated to the extent that it is no longer visually effective.	Minor
	c. any interlock and/or safety device applicable to folding, extendable and/or power steps is inoperative.	Major
12	<b>Kneeling suspension which:</b>	
	a. has an operating control which is inadequately marked.	Minor
	b. has controls which are incapable of stopping and reversing the lowering process.	Major
	c. does not have an effective interlock to prevent the vehicle from being driven at speeds in excess of 5km/h with the vehicle lower than normal height.	Major

# Public Service Vehicle Inspection Manual

## 25 Windscreen Washers and Wipers

### Application

This inspection applies to all vehicles except those with an opening windscreen or where an adequate view can be obtained by some other means.

### Procedure and Standards

**PSVs used for “local service”** operation do not require windscreen washers.

**Wipers must be able to clear an adequate area** of the screen to give the driver a view of the road to the front and in front of both sides of the vehicle.

**Washers must provide enough water** to enable the wipers to clear the screen effectively.

**Frozen washers** are to be considered a deficiency.

**There is no requirement** to check that wipers self park.

**Wipers working on an intermittent speed only** are not acceptable and will be a deficiency under 2b.

Check switches that control windscreen wipers and or washers are fitted and operational.

Deficiency	Deficiency Category
1 Switch(es) controlling windscreen wipers and/or washers missing or defective.	Minor
2 <b>Wipers:</b> a. do not move over an adequate area. b. do not work continually when switched on. c. a blade missing, insecure or so deteriorated that it cannot clear the screen effectively.	Major
3 Windscreen washers not working or not providing sufficient fluid to clear the windscreen.	Major

**Application**

This inspection applies to all vehicles.

A vehicle must have a tachograph fitted unless the presenter claims that it is exempt from the tachograph regulations. Exempt vehicles may have either a tachograph or a speedometer fitted.

**Procedure and standards**

**The check of tachograph seals** is by visual assessment only.

**1C tachographs must be installed** to all vehicles requiring a tachograph registered from June 15th, 2019.

1C tachograph seals have a `snap off` section which must be completely snapped off by the tachograph centre carrying out the tacho calibration/repair.

If this section has not been completely snapped off, the tachograph is deemed not to be **sealed in accordance with the regulations**. The deficiency 3.g (i) must be used and the vehicle must be presented for a retest with a new tacho calibration. Deficiency 3.g (ii) must be used if the tachograph has not been recalibrated for retest.

**All vehicles**

**A tachograph exemption form** must be completed for all vehicles deemed tachograph exempt, unless the vehicle technical record shows the vehicle is exempt or it is declared on the application form.

**For vehicles fitted with a tachograph**

**If the tachograph head cannot be opened** or if the calibration plaque does not match the vehicle to which it is fitted it should be treated as if the plaque and any relevant seals were not there.

If the vehicle identification on the calibration plaque does not correspond to the vehicle it is fitted to, the vehicle should be refused under 2a. Should the identification refer to the registration mark, the technical record must be checked to ensure it was not a previous registration for the same vehicle. If no vehicle identification is displayed this is not a deficiency, there is no requirement to display the registration mark on the calibration plaque.

**For vehicles required to be fitted with a tachograph**

**If the time clock is inoperative** this is a deficiency under 1b (ii) (for the tachograph only not the speedometer).

**Tachograph heads must** only be opened with the steering wheel in the straight ahead position and with the engine switched off.

**Installation/calibration plaques** expire after 6 years for analogue, 2 years for digital.

**It is acceptable for the plaque to contain additional information** (e.g. Registration Number, tyre pressures etc.). The plaque is designed to be tamper proof and should show signs of damage if it has been tampered with. The 2 year check is not part of this inspection for analogue tachographs only. However, if the examiner notices this plaque is not displayed the presenter must be advised.

26 Speedometer/Tachograph

**For vehicles not required to be fitted with a tachograph where a tachograph is used as a speedometer**

If a tachograph is used in place of a speedometer (even if the vehicle is tachograph exempt) it is only required to be marked in kilometres per hour, although it may be dual marked in miles per hour also.

Only where the tachograph is marked in KPH alone, will you be required to check the installation/calibration plaque for presence and condition, and the date of calibration is clearly visible.

There is no requirement for a re-calibration of these systems after 6 years provided that the system has been initially calibrated and sealed, and that the calibration plaque and necessary seals remain intact.

Check DIL switch covers and seals for presence and condition and that they are the correct type. It will be sufficient to check that they have an approved marking. It is not necessary to identify the sealer.

**If a speed limiter is NOT required, or the speed limiter does not** receive the speed signal from the tachograph head, it is only necessary to check the seals inside the tachograph head. There is no requirement for the gearbox sender unit to be sealed. The vehicle technical record will show if a vehicle is speed limiter exempt.

**Vehicles fitted with Modular Tachographs**

There are presently two types of modular tachograph using encrypted sender units. They are VDO Keinzel 1324 and Stoneridge Electronics (formerly TVI) and are easily identified as they are shaped like a car radio.

**Vehicles fitted with Modular Tachograph systems** have received type approval that permits the use of a 4 wire data transmission cable instead of an armoured cable provided it is used to connect an encrypted sender unit to the tachograph. When used in this arrangement the approval also does not require the cable end connections to be sealed. However, the sender unit itself is still required to be sealed to the gearbox.

The sealing wire, must be attached to the gearbox housing or secured/threaded through a bolt head fixed to the gearbox housing, so that the motion sensor could not be removed without breaking the seal and wire.

**Digital tachograph printout**

The purpose of producing a tachograph technical data printout at statutory test is to:

- check that a printout can be produced and
- compare the tachograph constant or K factor reading on the printout with that recorded on the tachograph installation plaque.

There may be occasions where several differing K factors are displayed on the printout.

The information on the printout is displayed in data blocks.

Next to the date within this block will be a number in brackets, for example (04) or (4), this number represents a description of the activity carried out at that time i.e. a periodic calibration.

- 03 - Initial Calibration
- 04 - Periodic Calibration
- 01 or data blocks with 01 and 02 activation/installation.

**Note:** *The printout can contain multiple data blocks:*

26 Speedometer/Tachograph

**Check the K factors in the following order:**

1. Use K factor from the most recent 04 block.
2. If 03 block is more recent than 04 (e.g., tachograph moved from another vehicle), use 03.
3. In the absence of 03 or 04, and when 01 & 02 are both present, these can be used.

**Where a printout from a digital tachograph cannot be obtained initially** (because of a jammed, depleted or missing roll) the presenter should be given the opportunity to rectify this before leaving the test is concluded and this will not be classed as a deficiency.

**Identification of Encrypted Sender Units**

These appear similar to other sender units and can be positively identified by the cream/beige colour of the sender unit 4 pin bayonet connector. This colour is the same whether the sender unit is the rotating type or a proximity type. It should be noted that when the cable is connected that only a small part of the cream/beige coloured connector is visible.

**For the VDO Keinzl 1324 that there is an exception to the above colour code when the vehicle is fitted with a TELMA retarder, the socket housing will be red.**

**If a vehicle is fitted with more than one tachograph** and a speed limiter, the speed limiter should operate off all tachographs.



**Plastic sleeve seals** are acceptable but will require an embossed identification, (see example to left).

**Tachograph plaques are required to be tamperproof; this is not a deficiency at annual test if they are not tamperproof.**

**Public Service Vehicle Inspection Manual**

**26 Speedometer/Tachograph**

<b>Deficiency</b>	<b>Deficiency Category</b>
<b>1</b>	
<b>A speedometer or tachograph (where required):</b>	
a. not fitted.	Major
b. (i) incomplete or dial glass broken without affecting the operation.	Minor
(ii) incomplete, clearly inoperative, or with dial glass missing or broken and affecting the operation.	Major
c. cannot be illuminated.	Major
<b>2</b>	
<b>For all vehicles fitted with a tachograph:</b>	
a. tachograph installation/calibration plaque missing, damaged (where required).	Major
b. DIL switch cover missing, broken or damaged through interference.	Major
<b>3</b>	
<b>For vehicles required to be fitted with a tachograph:</b>	
a. tachograph scale not marked in kilometres per hour (There is no requirement for tachographs to be marked in mph).	Major
b. tachograph manufacturer's serial number/data plaque missing or not showing an "e" marking.	Major
c. tachograph installation/calibration plaque out of date.	Major
d. where a digital tachograph is fitted the size of drive axle road tyres do not comply with calibration plaque.	Major
e. "K" factor plaque missing.	Major
f. seal missing, broken or where a clearly "non mandatory" seal has been fitted in place of an "official" seal.	Major
g. (i) The tachograph is not sealed in accordance with the regulations and must be re-calibrated before being presented for re-test.	Major
(ii) The tachograph has not been re-calibrated in accordance with the regulations.	Major
h. unable to obtain a printout from a digital tachograph.	Major

26 Speedometer/Tachograph

i.	a digital tachograph that displays a 'K' factor reading different to that shown on the calibration plaque (there is no allowance/tolerance as with analogue type tachographs).	Major
4	<b>For vehicles not required to be fitted with a tachograph, where a tachograph is fitted in place of a speedometer:</b>	
a.	<b>If a speed limiter is required (which is sensed from the tachograph head):</b> seal missing, broken or where a clearly "non-mandatory" seal has been fitted in place of an "official seal."	Major
b.	<b>If a speed limiter is not required:</b> a seal within the tachograph head missing, broken or where a clearly "non mandatory" seal has been fitted in place of an "official" seal. There is no requirement for the gearbox sender unit to be sealed.	Major

# Public Service Vehicle Inspection Manual

## 27 Horn

### Application

This inspection applies to all vehicles.

### Procedure and standards

Vehicles first used from 1 August 1973 must have a horn that produces a continuous or uniform sound.

**If vehicles are fitted with more than one horn** only one has to work.

**If air horns are connected to the braking system** of a vehicle the presenter should be made aware of the possible dangers as well as advising of any leaks from the air horns (there is no requirement to check if air horn operation depletes the braking system).

**If more than one horn control is fitted** at least one must operate the horn.

### Deficiency

### Deficiency Category

1	<b>Horn control:</b>	
	a. missing.	Major
	b. cannot be reached easily from the driving seat.	Major
	c. insecure.	Major
2	<b>Horn:</b>	
	a. does not work.	Major
	b. is not loud enough to be heard by other road users.	Major
	c. sound not continuous or uniform.	Major
	d. insecure.	Major

# Public Service Vehicle Inspection Manual

## 28 Driving Controls

<b>Application</b>	
This inspection applies to all vehicles.	
<b>Procedure and standards</b>	
<p>From the driver's seat operate driving controls, except those for brakes and steering which are checked under other items, to see that they function correctly and are complete.</p> <p>Examples of driving controls which need to be inspected are:</p> <ol style="list-style-type: none"> <li>1. Gear control.</li> <li>2. Accelerator pedal.</li> <li>3. Clutch pedal.</li> </ol> <p>The list is not exhaustive.</p> <p><b>An air leak from a gear valve</b> is not a deficiency.</p> <p><b>An accelerator pedal anti slip provision</b> missing or worn smooth is not a deficiency.</p> <p>Check the designated engine stop control for presence and operation.</p>	
<b>Deficiency</b>	<b>Deficiency Category</b>
<p>1                    <b>A driving control:</b></p> <p>    a. (i) insecure.</p> <p>        (ii) insecure and safe operation of the vehicle obviously affected.</p> <p>    b. (i) incomplete.</p> <p>        (ii) incomplete and safe operation of the vehicle obviously affected.</p> <p>    c. (i) fractured, cracked or excessively corroded.</p> <p>        (ii) fractured, cracked or excessively corroded and safe operation of the vehicle obviously affected.</p> <p>    d. (i) obstructed or impeded in its travel.</p> <p>        (ii) obstructed or impeded in its travel and safe operation of the vehicle obviously affected.</p> <p>    e. (i) obviously not functioning correctly.</p> <p>        (ii) obviously not functioning correctly and safe operation of the vehicle obviously affected.</p>	<p>Major</p> <p>Dangerous</p> <p>Major</p> <p>Dangerous</p> <p>Major</p> <p>Dangerous</p> <p>Major</p> <p>Dangerous</p> <p>Major</p> <p>Dangerous</p>

# Public Service Vehicle Inspection Manual

## 28 Driving Controls

f.	with the presence of rubbish or other items likely to interfere with the proper control of the vehicle.	Dangerous
g.	(i) clutch pedal anti-slip provision missing, loose, incomplete or ineffective.	Major
	(ii) clutch pedal anti-slip provision missing, loose, incomplete or ineffective and safe operation of the vehicle obviously affected.	Dangerous
2	Engine stop control missing or inoperative.	Major

**Application**

This inspection applies to all vehicles.

**Procedure and standards**

**Cracks in the plastic covering** do not necessarily mean that a spoke is fractured.

**This inspection does not apply to** drivers' aid steering wheel knobs.

**Unless specified by the manufacturer** vehicles fitted with power steering must be checked with the engine running.

**“Free Play” must not be confused with** movement caused by the compression of steering joints etc. This operation should be carried out with light finger pressure to distinguish the feel of the steering wheel when it meets a resistance.

**Certain types of steering column might show some movement** not due to excessive wear, e.g. those fitted with universal joints or flexible couplings.

**Free play at the steering rim in excess of** 1/30 of the steering wheel diameter for a rack and pinion mechanism is considered a deficiency. For other types of mechanism free play in excess of 1/5 of the wheel's diameter is considered a deficiency. The acceptable free play for a range of wheels is shown below.

Wheel Diameter	Rack and Pinion Steering		Other types of steering
	Conventional	With Steering wheel ahead of the rack with a number of joints	
380mm (15")	13mm (0.5")	48mm (1.9")	76mm (3")
455mm (18")	16mm (0.6")	57mm (2.3")	90mm (3.6")
530mm (21")	18mm (0.7")	67mm (2.6")	106mm (4.2")
610mm (24")	21mm (0.8")	77mm (3.3")	122mm (4.8")

Check the steering column has no excessive end float, when applying an upward and downward pressure to the steering wheel in line with the column.

Check the steering column has no excessive side play indicating a badly worn top bearing or insecure top mounting bracket, by pulling and pushing the rim.

With the steered wheels in the straight ahead position lightly rotate the steering wheel to the left and right and note the amount of free play.

**On vehicles that are equipped with a steering lock (anti theft device)** these should be checked for functionality. It's acceptable for a steering lock to be inoperative if the vehicle has an engine immobiliser, or a permanently installed immobilisation device which acts on either the steering, brakes or the transmission.

**Some electronic steering locks, generally on vehicles with keyless** ignition systems, will only activate when the driver's door is opened or closed.

**If it's not practical** to check if a steering lock is working, you should give the benefit of the doubt.

**Public Service Vehicle Inspection Manual**

**30 Steering Control**

<b>Deficiency</b>		<b>Deficiency Category</b>
1	<b>Steering column:</b>	
a.	with excessive movement of centre of steering wheel in line with the column (end float).	Major
b.	with excessive side play indicating a badly worn top bearing or insecure top mounting bracket.	Major
c.	flexible coupling or universal joint insecure, deteriorated or with excessive wear.	Major
d.	(i) coupling clamp bolt or locking device missing or loose.	Major
	(ii) coupling clamp bolt or locking device missing or loose with a serious risk of separation.	Dangerous
e.	(i) with an adjustment device worn to such an extent that it would render the column insecure.	Major
	(ii) with an adjustment device worn to such an extent that it would render the column insecure with a serious risk of loss of steering control.	Dangerous
f.	(i) with an inappropriate modification.	Major
	(ii) with an unsafe modification which has seriously weakened the component, does not provide sufficient clearance to other vehicle parts or affects the steering function.	Dangerous
2	<b>Steering Wheel:</b>	
a.	(i) insecure.	Major
	(ii) insecure to such an extent that detachment is likely.	Dangerous
b.	(i) hub, spoke or rim fractured or cracked.	Major
	(ii) hub, spoke or rim fractured or cracked to such an extent that detachment is likely.	Dangerous
c.	cover torn with jagged edges likely to injure the driver.	Dangerous*
d.	(i) hub retaining device not fitted or loose.	Major
	(ii) hub retaining device not fitted or loose and detachment is likely.	Dangerous

# Public Service Vehicle Inspection Manual

## 30 Steering Control

	e.	(i)	locking mechanism not functioning correctly.	Major
		(ii)	locking mechanism not functioning correctly and affects safe steering operation.	Dangerous
3		(i)	Free play in system which is outside the prescribed limits.	Major
		(ii)	Free play in system which is outside the prescribed limits obviously effecting safe control of the vehicle.	Dangerous

**Application**

This inspection applies to all vehicles which are required to be fitted with a speed limiter.

**Vehicles required to be fitted with a speed limiter are:**

**A. A vehicle first used from 1 April 1974 until 31 December 1987 with:**

- more than 16 passenger seats and
- a design gross weight of more than 7500kg and
- a maximum speed capability exceeding 70mph (112.65km/h), if a speed limiter were not fitted

Must be fitted with a speed limiter set at a maximum speed of 70mph (112.65km/h).

**B. A vehicle first used from 1 January 1988 until 30 September 2001 with:**

- more than 8 passenger seats and
- a design gross weight of more than 7500kg and less than 10001kg
- a maximum speed capability exceeding 100km/h (62.14mph) if a speed limiter were not fitted

Must be fitted with a speed limiter set at a maximum of 100km/h.

**C. A vehicle first used from 1 October 2001 with:**

- more than 8 passenger seats and
- a design gross weight of more than 7500kg and less than 10001kg
- a maximum speed capability exceeding 100km/h (62.14mph) if a speed limiter were not fitted

Must be fitted with a speed limiter set at a maximum stabilised speed of 100 km/h.

**D. A vehicle first used from 1 January 1988 until 31 December 2004 with:**

- more than 8 passenger seats and
- a design gross weight of more than 10000kg
- a maximum speed capability exceeding 100km/h (62.14mph) if a speed limiter were not fitted

Must be fitted with a speed limiter set at a maximum of 100km/h.

**E. A vehicle first used from 1 October 2001 and 31 December 2004 with a Euro 3 diesel or gas engine (see note) and:**

- more than 8 passenger seats and
- a design gross weight of less than 7501kg and
- a maximum speed capability exceeding 100km/h if a speed limiter were not fitted

Must be fitted with a speed limiter set at a maximum stabilised speed of 100 km/h

**F. A vehicle first used from 1 January 2005 with:**

- more than 8 passenger seats and

33 Speed Limiter

- a design gross weight up to 5000kg
  - a maximum speed capability exceeding 100km/h if a speed limiter were not fitted
- Must be fitted with a speed limiter set at a maximum stabilised speed of 100 km/h.

G. **A vehicle first used from 1 January 2005 with:**

- more than 8 passenger seats and
  - a design gross weight from 5001kg to 7500kg
  - a maximum speed capability exceeding 100km/h, if a speed limiter were not fitted
- Must be fitted with a speed limiter set at a maximum stabilized speed of 100km/h.

H. **A vehicle first used from 1 January 2005 with:**

- more than 8 passenger seats
  - a design gross weight in excess of 10000kg
  - a maximum speed capability exceeding 100km/h, if a speed limiter were not fitted
- Must be fitted with a speed limiter set at a maximum stabilized speed of 100km/h.

**Procedure and standards**

**Some vehicles first used from 1 October 2001 until 31 December 2004 may have been approved to Directive 70/220/EC** or fitted with Euro 2 engines. These vehicles are exempt from the speed limiter fitting requirements for Group E. Where exemption is claimed at time of test this should be accompanied by an operator's declaration of exemption and where necessary supported by manufacturer's confirmation of emission test standard, unless the vehicle is marked speed limiter exempt on the technical record. All the following listed vehicles have already been confirmed by their manufacturers as being exempt and no further proof is required for these vehicles:

**Any** Petrol engine or petrol engine converted to run on LPG

**Citroen Relay** 2.0 litre and 2.2 litre HDi engines

**DAF 45**, 7.5 ton vehicles (all) except DAF 45 marked as LF. (LF is marked on the N/S of the radiator grill.)

**Fiat Ducato** with 2.0 litre engines (engine code RHV).

**Ford Transit** (all).

**Isuzu** models NPR, NQR, and NKR with T, V, W, X or 1(one) as the 10<sup>th</sup> VIN character.

**Iveco Cargo** all, except vehicles with engine code F4AE---

**Iveco Daily** all, except vehicles with engine code F1CE---, 8140.43B, 8140.43N and 8140.43S with a PIC code 'G.' (the PIC code is applicable to the 8140.43S only, the PIC code can be found on the ID plate on the shut panel for the bonnet identified by the third character.)

**LDV** (all).

**Mitsubishi Canter** with 'R' as the 12<sup>th</sup> VIN character.

**Nissan Interstar** all, except vehicles with engine code ZD3-A202, G9U-A754 & G9U-A724.

**Nissan Primastar** All models.

**Peugeot Boxer** 2.0 litre and 2.2 litre HDi engines.

**Renault Master** all, except vehicles with engine code ZD3-A202, G9U-A754 & G9U-A724.

**Renault Trafic** All models.

**Vauxhall/Opel Movano** with E, F, G, J, K, L, M, N, P, T or W as the 7<sup>th</sup> VIN character.

**Vauxhall/Opel Vivaro** (all).

**Volkswagen** (all except 2.5lt/2.8lt 109bhp/158bhp engine codes AVR & AUH respectively).

**Other vehicles which are exempted by regulations are:**

Vehicles owned or used by the Secretary of State for Defence and used for naval, military or air force purposes. If the vehicle is being used the driver must be under the direct orders of a member of the armed forces of the Crown.

Vehicles being used for fire brigade (in England and Wales fire and rescue authority), ambulance and police purposes.

Vehicles which are operated on behalf of His Majesty's Prison Service and used primarily for the purpose of moving category A prisoners (Category A prisoners means that prison security category which is applied to prisoners whose escape would be highly dangerous to the public, police or the security of the state, no matter how unlikely that escape might be, and from whom the aim must be to make escape impossible).

**If for any other reason the vehicle presenter claims a valid exemption** that is different from the technical record, form DVSA 73 V2 must be completed.

**When checking a speed limiter plate is securely fitted** in the driver's compartment it is acceptable for the plate to be fitted in the driver's door jamb. If fitted on a window and facing outward the details must be able to be read by a person of average height.

**The character and composition of the plate and size** of the lettering are not important provided the details are legible.

**It is acceptable for the limiter to be wired through the "ignition"** switch but any other device which would allow disconnection of the speed limiter whilst driving is unacceptable.

**Clear DIL switch covers are acceptable at the time of test**, although once again they are no longer acceptable under the Tachograph approved scheme and centres should no longer fit them.

**The inspection of speed limiters is only for the parts** which are visible without dismantling.

**Plastic speed limiter seals are acceptable** if they are properly marked with a sealer identification.

**Public Service Vehicle Inspection Manual**

**33 Speed Limiter**

<b>Deficiency</b>		<b>Deficiency Category</b>
1	<b>Speed Limiter Plate:</b>	
a.	missing.	Major
b.	insecure.	Minor
c.	not in a conspicuous position.	Minor
d.	not clearly and indelibly marked with the set speed.	Major
2	<b>Set Speed marked on Speed Limiter. Plate greater than:</b>	
a.	70mph (113 km/h) for a vehicle described in paragraph A in the Applications section.	Minor
b.	100 km/h (62.14 mph) for a vehicle described in paragraph B, C, D, E, F, G & H in the Application section.	Minor
3	<b>Speed limiter:</b>	
a.	not fitted or obviously inoperative.	Major
b.	insecure.	Major
c.	actuating rods/cables disconnected or damaged so that the operation is obviously affected.	Major
d.	wiring disconnected or can easily be disconnected by unauthorised means.	Major
e.	tamperproof device missing or defective or showing obvious signs of interference.	Major

**Public Service Vehicle Inspection Manual**  
**34 Pressure/Vacuum Warning and Build Up**

**Application**

This inspection applies to all vehicles, except those with an unladen weight of less than 3050kg where the vacuum reservoir is coupled direct to the engine induction manifold. These vehicles do not require a pressure/vacuum warning device (if it is not possible to determine the unladen weight of a vehicle, the presenter should be given the opportunity to produce some evidence of the unladen weight before failing the vehicle).

**Procedure and Standards**

Vehicles used from 1 April 1983 can be fitted with either a visual warning device or an audible warning device. If both are fitted only one need work. Vehicles first used before 1 April 1983 must be fitted with a visual warning device. If an audible warning device is also fitted this is considered to be an addition to the mandatory requirement.

A Number of vehicles, among them Mercedes 515, 609, 612, 614, 709 and Iveco Daily models were approved without a warning device and should not be failed for a warning device not fitted.

If there is no reservoir in a vacuum system a warning device is not required.

Deplete the air or vacuum system by applying the footbrake, when the warning device operates there must be four further assisted applications.

**If the vehicle has full power hydraulic brakes** gauges are not normally fitted and there are no appreciable sounds when the brakes are applied. To check for compliance, use the procedure shown in IM 71.

Fully deplete the system and run the engine at just below governed speed and note the time for the warning device to show minimum effective working condition.

**If gauges are not marked**, take 3 bar (45 psi) for air systems and 25 to 30cm (10 to 12 Inches) for vacuum systems as indicating minimum effective working condition.

**The time to reach minimum effective working pressure** should normally be within 3 minutes for pressure systems and 1 minute for vacuum systems.

**Public Service Vehicle Inspection Manual**  
**34 Pressure/Vacuum Warning and Build Up**

Deficiency	Deficiency Category
1	<b>A mandatory visual warning device:</b>
a.	cannot be seen by the driver in all lighting conditions or heard as applicable. Major
b.	not fitted or not working correctly. Major
2	(i) Not enough pressure or vacuum to give at least <b>four</b> fully assisted brake applications after the warning device has indicated minimum effective working conditions. Major
	(ii) Not enough pressure or vacuum to give at least <b>two</b> fully assisted brake applications after the warning device has indicated minimum effective working conditions. Dangerous
3	Time to reach minimum effective working pressure is more than 3 minutes for pressure systems and 1 minute for vacuum systems. Major

## Public Service Vehicle Inspection Manual

### 36 Hand Lever Operating Mechanical Park Brakes and Electronic Park Brake Controls

#### Application

This examination applies to all vehicles fitted with a mechanical parking brake and all vehicles fitted with an electrical park brake control.

#### Procedure and Standards

Operate the vehicles parking brake mechanism and check the operation and condition.

Deficiency	Deficiency Category
------------	---------------------

1	<b>Brake lever:</b>	
	a. fractured or cracked.	Major
	b. excessively corroded.	Major
	c. insecure.	Major
	d. so positioned that it cannot be operated satisfactorily.	Major
	e. impeded in its travel.	Major
	f. is not held in the "on" position when knocked.	Major
	g. excessive or insufficient reserve travel.	Major
	h. pivot with side play such that it is likely to fail.	Major
	i. pivot is tight in operation.	Major
	j. (i) does not release correctly.	Minor
	(ii) does not release correctly and is functionally affected.	Major
2	<b>Pawl mechanism:</b>	
	a. and/or mountings in such a condition that early failure is likely.	Major
	b. pawl spring is not pushing teeth into positive engagement with ratchet teeth.	Major
3	Locking and/or retaining devices missing or insecure.	Major
4	<b>Electronic Park Brake control:</b>	
	a. activator missing, damaged or inoperative.	Major
	b. incorrect functionality, warning indicator shows malfunction.	Major

# Public Service Vehicle Inspection Manual

## 37 Service Brake Pedal

### Application

This examination applies to all vehicles.

### Procedure and Standards

**Power operated braking systems** where the foot valve is fully open before the pedal is fully depressed do not require any reserve travel.

### Deficiency

### Deficiency Category

- | Deficiency  | Deficiency Category |
|---|---------------------|
| <b>1 Brake pedal:</b>   |                     |
| a. anti-slip provision missing, loose, incomplete or ineffective.                       | Major               |
| b. has excessive side play.   | Major               |
| c. fouling other parts of the vehicle and is functionality affected.                    | Major               |
| d. insufficient reserve travel when fully depressed.                                    | Major               |
| <b>2 Brake pedal or assembly:</b>   |                     |
| a. insecure, incomplete, fractured, cracked, or corroded and is functionality affected. | Major               |
| b. pivot is tight in operation.   | Major               |
| c. (i) does not release correctly.  | Minor               |
| (ii) does not release correctly and functionality is affected.                          | Major               |

**Application**

This examination applies to all vehicles.

Anti-lock brakes are mandatory on coaches first used from 1 April 1992 with design GVW greater than 12000kg, and all passenger carrying vehicles with more than eight passenger seats in addition to the driver first used from 1<sup>st</sup> May 2002.

**Procedure and Standards**

**For some brake systems a small amount of brake pedal creep** may be due to elasticity in the brake components.

**Air pressure or vacuum systems:** With the ignition on and with the reservoir at maximum pressure or vacuum, fully depress the pedal and note the change in gauge readings to see if they give indications of a leak in the system.

**Hydraulic systems (other than full power systems),** With the engine off, fully depress the pedal and keep it depressed under steady pressure and check: a. that the pedal does not creep down under full pressure. b. there is no sponginess.

**Brake systems assisted by engine vacuum:** With the engine running, deplete the vacuum, partly depress the pedal, start the engine, and check if the pedal can be felt to dip.

**Full pressure hydraulic systems:** Check that the system pressure is maintained for at least 10 minutes when the brakes are off and the engine is stopped. Loss of pressure will be indicated by the operation of the low-pressure warning device (warning light or appearance of semaphore "flag" device).

**ABS, ABS/EBS and ABS/EBS/ESC requirements**

**ABS only vehicles**

Vehicles fitted with ABS only must have a mandatory warning malfunction indicator lamp (MIL) that illuminates when the system is energised (ignition or battery master switch on). It can be any colour, though they are usually red, yellow or amber. It must go out after a short period or when the engine is started but can then come back on and remain on until the vehicle speed exceeds approximately 5 kph (3 mph). It is not necessary to move the vehicle to check the speed-activated function provided the lamp does go off momentarily.

Other lamps of the same or different colours showing e.g. that trailers are not connected, or are not fitted with ABS may also be fitted to motor vehicles. These are not mandatory and are for information purposes only. If these are illuminated it is not a deficiency. It is important to establish that a lit warning lamp is actually showing an ABS defect, and is not an ABS information lamp. The Driver Handbook may be used to establish the function of a lamp.

**ABS/EBS equipped vehicles**

Vehicles fitted with ABS and EBS must have mandatory red and amber/yellow MILs fitted. The red MIL illuminates if there is a foundation brake fault or the prescribed minimum brake performance cannot be met.

The red MIL must illuminate with system initialisation though this may not be clearly evident as in some cases the sequence is extremely fast and may be missed. In this circumstance if modulator cycling can be heard it is acceptable to pass the vehicle. It may be necessary to wait as much as 30 seconds before re-testing to allow the system to re-set. If a red MIL stays lit or is flashing this is a deficiency.

The amber/yellow lamp illuminates if there is an electronic fault.

The amber/yellow MILs must illuminate with system initialisation though this may not be clearly evident as in some cases the sequence is extremely fast and may be missed. In this circumstance if modulator cycling can be heard it is acceptable to pass the vehicle. If the MIL stays lit this is a deficiency. It may be necessary to wait as much as 30 seconds before re-testing to allow the system to re-set. If the MIL illuminates on system initialisation, then goes out and then flashes this should be advised.

### **ABS/EBS/ESC equipped vehicles**

Motor vehicles fitted with ESC must have a separate amber/yellow MIL fitted apart from those used to signal EBS electronic faults. One lamp covers both the motor vehicle and any trailer fitted with ESC towed.

The ESC lamp will be illuminated when the system is switched off, when the system is operating or if a fault is present. It is not required to light up on system energisation, but if it does this is acceptable provided it then goes out after a short period or when the engine is started.

If the vehicle has a switch to manually disable the ESC function, it must not be possible for the switch to be left in the "off" position and the ESC function must be automatically reinstated every time the system is re-energised (ignition turned on.)

Electronic Stability Control Systems are commonly referred to as ESC, but may also be known as ESP/RSC or some other acronym. The MIL for these systems may take various forms and a vehicle should only be refused when the tester is certain that an illuminated lamp indicates an ESC malfunction. This may require reference to the owner's handbook if one is available.

### **Multifunctional MILs**

Some type approved ABS/EBS/ESC systems, will only illuminate a MIL when the vehicle detects a fault. The MIL will not illuminate during its system energisation check, as it is often a multifunctional MIL, which may differ from the standard recognised MILs for ABS/EBS/ESC system.

If the multifunctional MIL remains on after energisation, the system affected will display a fault message in an information screen on the dashboard. This should be considered a deficiency under IM38, 5c.

**Public Service Vehicle Inspection Manual**

**38 Service Brake Operation**

<b>Deficiency</b>		<b>Category</b>
1	Air pressure or vacuum systems gauge reading drops when pedal depressed indicating a leak in the system.	Major
2	<b>Hydraulic systems (other than full power systems):</b>	
	a. pedal creeps down to the floor when depressed.	Major
	b. sponginess when pedal depressed.	Major
3	(i) Servo unit defective or ineffective.	Major
	(ii) Pedal does not dip when engine started, indicating lack of assistance for brake systems assisted by engine vacuum.	Dangerous*
4	Full pressure hydraulic system pressure is not maintained for 10 minutes when the brakes are off and the engine is stopped.	Major
5	<b>Any of the required ABS or ABS/EBS or ESC warning lamps:</b>	
	a. are missing.	Major
	b. do not illuminate as required when ignition switched on.	Major
	c. indicate a fault.	Major
6	<b>Vehicles fitted with ABS or ABS/EBS or ESC:</b>	
	a. a system component obviously missing or excessively damaged.	Major
	b. system wiring excessively damaged.	Major
	c. (i) a system component with an inappropriate modification.	Major
	(ii) a system component with an unsafe modification which has seriously weakened the component, does not provide sufficient clearance to other vehicle parts or renders the component inoperative.	Dangerous
	d. an ESC system switch insecure or faulty or which does not allow automatic resetting of the ESC function to "on" at system energisation.	Major

# Public Service Vehicle Inspection Manual

## 38 Service Brake Operation

7	On vehicles and trailers both fitted with ISO 7638 (ABS/EBS) lead sockets an ISO 7638 connecting lead not fitted or being used.	Major
8	A mandatory ABS system not fitted to a vehicle where it is a mandatory requirement.	Major

**Public Service Vehicle Inspection Manual  
39 Hand Operated Brake Control Valves**

**Application**

This examination applies to all hand operated control valves on vehicles which operate secondary brakes, trailer brakes, spring brakes and lock actuators.

**Procedure and Standards**

**Certain air valves are subject to a slight** amount of leakage, and this is not a deficiency.

**Deficiency**

**Deficiency  
Category**

1	<b>Control valve:</b>	
	a. on a motor vehicle unable to be operated from the driving position.	Major
	b. insecure.	Major
	c. fractured, cracked, damaged or excessively corroded.	Major
	d. impeded in its travel.	Major
	e. leaking.	Major
	f. excessive wear in the gate or lever located mechanism.	Major
	g. malfunctioning.	Major

# Public Service Vehicle Inspection Manual

## 41 Condition of Chassis

### Application

This inspection applies to all vehicles.

### Procedure and Standards

**For integral construction the term chassis** should also be taken to apply to the underframe. For vehicles without a chassis those parts of the body must be examined which take the place of the chassis.

**When assessing corrosion it must only be regarded as a deficiency if** it is sufficiently advanced to obviously impair the strength of a load bearing member.

### Deficiency

### Deficiency Category

1	<b>Any main or cross member:</b>	
a.	(i) fractured, cracked, corroded, or deformed.	Major
	(ii) fractured, cracked, with excessive corrosion, or deformed, so that the control of the vehicle is likely to be affected.	Dangerous*
2	<b>Frame and/or cross member fastenings:</b>	
a.	(i) insecure flitch plates and/or fastenings or welds breaking away.	Major
	(ii) insecure flitch plates and/or fastenings or welds breaking away so that the control of the vehicle is likely to be affected.	Dangerous*
3	<b>Integral body replacement panels:</b>	
a.	(i) of an obviously unsuitable material.	Major
	(ii) of an obviously unsuitable material and stability impaired.	Dangerous*
b.	(i) not adequately secured by an appropriate method.	Major
	(ii) not adequately secured by an appropriate method and stability impaired.	Dangerous*

# Public Service Vehicle Inspection Manual

## 42 Electrical Wiring and Equipment

<b>Application</b>	
This inspection applies to all vehicles.	
<b>Procedure and Standards</b>	
<p><b>If the battery is only held in place by the cables and by a lip on the carrier</b> this cannot be considered to be secure.</p> <p><b>Switches not on the main switch or control panel</b> and which are not likely to confuse the driver by their presence are not required to be marked.</p> <p><b>There is no need to remove destination box panels, as a matter of course.</b> The inspection requires a check on all <b>visible</b> wiring for condition, position and security. The test is generally limited to those parts which can be seen without dismantling and is based on the assumption that panels will only be removed where it is not possible to inspect safety critical items. We wouldn't normally consider that this would apply to wiring contained in destination box panels unless there was reason to suspect seriously defective wiring.</p> <p><b>The check on electrical circuits</b> over 100 volts for protection by double pole switches or isolating switches and located inside the vehicle and accessible to the driver or crew also includes any external mains power supplied to the vehicle.</p> <p>Where it is not possible to inspect batteries for condition and leaks every effort should be made to inspect the area where the batteries are installed to confirm there are no signs of leakage.</p> <p>When checking the condition and security of the wiring, care needs to be taken when inspecting the high voltage systems of Hybrid Electric Vehicles and Electric Vehicles. These high voltage wires are colour coded orange.</p> <p><b>A trailer electrical socket with a defective or missing cover flap</b> that incorporates a lug and spring to hold the plug in place is not considered to be a defect.</p>	
<b>Deficiency</b>	<b>Deficiency Category</b>
<p>1                      <b>Wiring:</b></p> <p style="padding-left: 40px;">a.        (i)        chafing, damaged or deteriorated insulation.</p> <p style="padding-left: 80px;">(ii)        chafed, damaged or deteriorated insulation, which is likely to cause a short circuit fault.</p> <p style="padding-left: 80px;">(iii)        chafed, damaged or deteriorated insulation, with obvious risk of fire.</p> <p style="padding-left: 40px;">b.        (i)        not adequately secured.</p> <p style="padding-left: 80px;">(ii)        not adequately secured with fixings touching sharp edges and or connectors likely to be disconnected.</p> <p style="padding-left: 80px;">(iii)        not adequately secured and wiring likely to touch hot or rotating parts or the ground.</p>	<p>Minor</p> <p>Major</p> <p>Dangerous</p> <p>Minor</p> <p>Major</p> <p>Dangerous*</p>

# Public Service Vehicle Inspection Manual

## 42 Electrical Wiring and Equipment

2	<b>Battery:</b>		
	a.	(i) and/or carrier insecure.	Minor
		(ii) and/or carrier insecure and likely to become displaced or cause a short circuit.	Major
	b.	case leaking.	Major
	c.	switch or fuse defective.	Major
	d.	container inadequately vented.	Major
	e.	cell closures missing or insecure.	Major
3	<b>A trailer electrical socket:</b>		
	a.	(i) insecure.	Minor
		(ii) insecure and likely to become detached.	Major
	b.	(i) damaged or deteriorated.	Minor
		(ii) damaged or deteriorated to the extent that the connecting lead cannot be securely connected.	Major
4	<b>A Power train:</b>		
	a.	insecure.	Major
	b.	presents a risk of fire or injury.	Dangerous
5	<b>Circuits of over 100 volts are not:</b>		
	a.	protected by double pole switches or isolating switches.	Major
	b.	situated inside the vehicle.	Minor
	c.	accessible to the driver or crew.	Minor
6		Television receiver visible to the driver whilst driving.	Major
7		Ignition or charging system not adequately suppressed.	Minor

**Public Service Vehicle Inspection Manual**  
**43 Engine and Transmission Mountings**

**Application**

This inspection applies to all vehicles, including Hybrid Electric Vehicles and Electric Vehicles. Where there is separate power train equipment, this should be treated as an engine/transmission.

**Procedure and Standards**

**Serious fractures in clutch or bell housings** which affect the security of the engine or gearbox are to be considered a deficiency.

<b>Deficiency</b>	<b>Deficiency Category</b>
<p>1                    <b>Any mounting or subframe:</b></p> <p>    a. (i)    securing nuts/bolts loose or missing.</p> <p>          (ii)    securing nut/bolts loose or missing to such an extent that road safety is endangered.</p> <p>    b. (i)    cracked or fractured.</p> <p>          (ii)    cracked or fractured to such an extent that road safety is endangered.</p> <p>    c. (i)    badly deteriorated.</p> <p>          (ii)    badly deteriorated to such an extent that road safety is endangered.</p>	<p>Major</p> <p>Dangerous*</p> <p>Major</p> <p>Dangerous*</p> <p>Major</p> <p>Dangerous*</p>

# Public Service Vehicle Inspection Manual

## 44 Oil and Waste Leaks

### Application

This inspection applies to all vehicles.

### Procedure and Standards

Check for oil leaks without operating any equipment other than the engine which may be run at tick-over speed.

**Very bad oil leaks are a reason for refusing to carry out the test.** If the test is suspended for this reason the presenter will be notified of this using form VTP12.

**Oil deposited onto body work**, exhaust or brake systems should not be categorised as deficient unless the leak causing the deposit exists at the time of test.

**Temporary means of preventing leaked oil** reaching the ground such as fabricated drip trays consisting of sheet metal supported by wire strands are not acceptable.

**Fabricated repairs to an oil pipe** which effectively stop an oil leak are acceptable.

**“Waste” includes effluent from toilets** and other devices but does not include water from sinks.

### Deficiency

### Deficiency Category

1	(i) Any oil leak which can deposit oil at a rate in excess of a 75mm diameter pool in 5 minutes or a number of leaks which collectively would deposit oil in excess of this.	Major
	(ii) Any oil leak which can deposit oil in a continuous flow or constitutes a serious risk of fire.	Dangerous
2	Leakage of waste which is likely to cause unpleasant or dangerous conditions for other road users or damage road surfaces.	Major
3	Leakages which when the vehicle is in motion, can heavily contaminate the vehicle such that it causes a health or fire risk.	Major

# Public Service Vehicle Inspection Manual

## 45 Fuel Tanks and System

### Application

This inspection applies to **all fuel tanks** which are permanently attached to vehicles and to trailers, including gas fuel tanks and cylinders, bottles and other types of fuel container.

For Hydrogen Fuel Cell vehicles, hydrogen tanks will be classed as fuel tanks.

### Procedure and Standards

**Seepage** is not a deficiency.

**Fabricated and "emergency" fuel caps** are acceptable provided that they function correctly. Where possible the tank cap should be opened to check the sealing arrangements.

**Very bad fuel leaks are a reason for refusing** to carry out the test. If the test is suspended for this reason the presenter will be notified of this using form VTP12.

**A fuel leak caused by a defect contaminating** the road surface will be considered a hazard to other road users.

**If the vehicle is powered by gas and suffers a leak** this should be treated in the same manner as a normal fuel leak and VTG12 action taken. The vehicle should be moved to a well ventilated area away from people and buildings. If the leak is of a serious nature evacuate the building.

**It is not necessary to run the engine but if a leak** is present when the engine is running this is considered a deficiency under 2a.

**It is not necessary to run combustion heaters** as part of this inspection.

**If a fuel tank assembly is seen to be holed**, but the hole is above the fuel level, this is considered a deficiency under 1d.

**Where possible, LPG, CNG, LNG and Hydrogen** tanks should be inspected for damage (including dents) and corrosion. There will only be a deficiency where damage and/or corrosion is considered excessive.

**Note:** corrosion will only normally apply to type 1 (steel tanks).

**Public Service Vehicle Inspection Manual**

**45 Fuel Tanks and System**

<b>Deficiency</b>		<b>Deficiency Category</b>
1.	<b>Fuel tank:</b>	
a.	strap or support broken or missing.	Major
b.	so insecure on its mountings that it is likely to drop away partially or completely when the vehicle is used.	Dangerous*
c.	heat shield missing, or defective to such an extent it constitutes an obvious fire risk.	Dangerous
d.	defective such that leakage of fuel is possible.	Major
e.	LPG/CNG/LNG/Hydrogen tank excessively damaged and/or corroded	Major
2.	<b>Fuel System:</b>	
a.	(i) leaking and does not represent an obvious hazard to other road users.	Major
	(ii) leaking and represents an obvious hazard to other road users.	Dangerous
b.	(i) pipes damaged (restricted/chafed) or so positioned that they are fouled by moving parts of the vehicle.	Minor
	(ii) pipes so damaged (restricted/chafed), insecure or with an inadequate repair, such that they are likely to fail and leak which would cause danger to persons on the vehicle or to other road users.	Major
c.	with a pipe or pipes immediately adjacent to or in contact with electrical wiring.	Major
d.	carburettor drip tray and/or drain pipe missing.	Major
3.	<b>Filler Cap:</b>	
a.	missing.	Dangerous
b.	does not fasten securely: <ul style="list-style-type: none"> <li>• by a positive means, or</li> <li>• such that pressure is not maintained on the sealing arrangement.</li> </ul>	Major
c.	sealing washer torn, deteriorated or missing, or a mounting flange/sealing method defective such that leakage of fuel is possible.	Major

**Application**

This inspection applies to all vehicles.

This inspection applies to all under bonnet noise deadening material fitted as original equipment.

This inspection includes ancillary equipment such as toilets, cooking, heating, catering, entertaining and any other special features.

**Procedure and Standards**

**Where a vehicle is refused for exhaust system leaking**, the emission test could be affected by the induction of air into the exhaust system. When presented for retest the emission test must be rechecked.

**Minor leaks** are acceptable.

**The position of exhaust outlets should be at the rear or offside** of the vehicle. This is not a requirement for Bus directive or ECE Regulation vehicles.

**The inspection of grease shields is only concerned with** those approved at the time the vehicle was certified, or where there is evidence that grease is being thrown onto the hot part of the exhaust pipe. There is no requirement for schedule 6 minibuses to be fitted with exhaust grease shields.

**An excessively deteriorated exhaust** is not a deficiency providing deficiencies 1.a and 1.b do not apply.

Check for the presence of the silencer and assess its effectiveness in reducing, so far as is reasonable, noise caused by the exhaust.

**Public Service Vehicle Inspection Manual**  
**46 Exhaust Systems and Nuisance**

<b>Deficiency</b>	<b>Deficiency Category</b>
1	<b>An exhaust system:</b>
a. (i)	insecure but unlikely to fall away partially or completely from the vehicle. Major
(ii)	so insecure that it might fall away partially or completely when the vehicle is in use. Dangerous*
b. (i)	leaking. Major
(ii)	leaking and entering the drivers cab and/or passenger compartment. Dangerous
c. (i)	incorrectly positioned so that fumes are likely to enter the driver's cab or passenger compartment. Major
(ii)	positioned so that fumes are entering the driver's cab and/or passenger compartment. Dangerous
d.	likely to cause a fire. Dangerous
2	<b>An exhaust silencer:</b>
a.	missing. Major
b.	obviously ineffective. Major
3	<b>Any part of the noise suppression system:</b>
(i)	insecure. Major
(ii)	likely to become detached. Dangerous*
4	Any exhaust or waste system fouling or likely to cause a fume hazard. Major
5	Missing or inadequate grease shields to hot exhausts. Major

**Application**

This inspection applies to all vehicles.

**Procedure and Standards**

**Insecurity of attachment points can best be assessed** when the steering and/or brakes are operated.

**Leaf spring systems:**

- Where leaves are so misaligned that each leaf is not taking a reasonable proportion of the load this will be a deficiency.
- A leaf spring with a fracture or crack on the curled section which prevents the axle moving in the event of main leaf failure is a deficiency.
- A "U" bolt should only be regarded as loose if there is clear visual evidence that it is not properly fulfilling its function of securing a spring and before it can do so it needs remedial action.
- Surface cracks on laminated semi-elliptical springs are not a deficiency.
- It is permissible to have a larger road spring on one side of a vehicle than the other.

**Spring Pins:**

- The maximum permissible wear in a pin/bush and/or mounting is 2mm for a 12mm diameter pin and 1/8 of the diameter for larger assemblies. For a threaded pin it is the diameter of the threaded part which should be taken into account when assessing wear. These criteria should not be used when checking rubber bushes which should be checked for deterioration of the rubber which could result in excessive movement.
- The maximum side play must not exceed 6mm. This does not apply to a threaded pin and bush assembly or to rubber bushes or to single spring bogie suspensions.
- Where an anchor/shackle pin is secured at one end the maximum amount of movement at the free end should not exceed 1mm for smaller assemblies, increasing to 2mm for larger assemblies.

**Slipper brackets:**

- Rebound pins where fitted as standard should be correctly located.
- Worn slipper brackets are considered a deficiency when worn to the extent they could, at the time of the inspection, clearly affect the movement or correct location of the road spring (or have allowed the spring leaf to damage the chassis).

**Air/Fluid systems:**

- When assessing the significance of leaks it should be remembered that certain pneumatic components are subject to some degree of leakage. Slight seepage producing a thin film of oil on the component is not a deficiency but any sign of dripping is unacceptable.
- Exposure of air bag structural cords is acceptable providing that they are not damaged to such an extent the unit is likely to fail.
- An air bag for holding a lift axle in the raised position must be considered against the same criteria as any other suspension air bag.

48 Suspension

**A fractured and or repaired air bag pedestal** if performing satisfactorily and not damaging the air bag is not a major deficiency.

**Independent suspension** must be jacked to remove the weight from the suspension joints (suspension hanging freely) except for independent assemblies with kingpins.

**Scania vehicles with air suspension** have attachment points for a retaining chain, the omission of the chain is not a deficiency.

**Shock Absorbers/Anti Roll Bars:**

- Slight seepage producing a thin film of fluid on a shock absorber is not a deficiency but any sign of dripping is unacceptable.
- Anti roll bar bushes repaired with resin are acceptable providing the repair is adequate resulting in the removal of the excess wear.

# Public Service Vehicle Inspection Manual

## 48 Suspension

Deficiency	Deficiency Category
1	<b>All suspension types - A suspension component or its attachment point:</b>
a. (i)	insecure. Major
(ii)	insecure to such an extent that detachment is likely. Dangerous
b.	disconnected. Dangerous
c.	fractured or cracked. Major
d. (i)	so damaged, worn, distorted or corroded that it adversely affects its function. Major
(ii)	so damaged, worn, distorted or corroded that it adversely affects its function and obviously affects directional stability. Dangerous
e. (i)	incorrectly located or fitted or a secondary spring leaf missing. Major
(ii)	a main spring leaf, multiple spring leaves or any other type of suspension spring assembly missing. Dangerous
f.	rubber or bonded bush deteriorated. Major
g.	defective such that a wheel could foul any other part of the vehicle or is fouling any part of the vehicle. Dangerous*
h. (i)	with wear in a pin, bush or mounting exceeding the prescribed limit. Major
(ii)	with wear in a pin, bush or mounting exceeding the prescribed limit which obviously affects directional stability. Dangerous
i. (i)	a ball joint dust cover deteriorated. Minor
(ii)	a ball joint dust cover missing, insecure, excessively damaged or severely deteriorated to the extent that it would no longer prevent the ingress of dirt etc. Major
j. (i)	a system component with an inappropriate modification. Major
(ii)	a system component with an unsafe modification which has seriously weakened the component, does not provide sufficient clearance to other vehicle parts or renders the suspension component inoperative. Dangerous
k.	Anti roll bar assembly missing from a vehicle on which it is a standard component or any of its associated linkage/brackets or bushes missing. Major

- 2                    **Leaf Springs and Fixings:**
- |    |   |           |
|----|---|-----------|
| a. | (i) fractured or cracked leaf or one repaired by welding.   | Major     |
|    | (ii) fractured or cracked leaf or one repaired by welding, which obviously affects directional stability.           | Dangerous |
| b. | spring leaves splayed beyond the prescribed limits or fouling any other part of the vehicle.                        | Major     |
| c. | with excessive movement in a spring fixing pin.   | Major     |
| d. | (i) slipper bracket rebound pin missing or incorrectly located.   | Minor     |
|    | (ii) slipper bracket rebound pin missing or incorrectly located with a spring displaced.                            | Major     |
| e. | (i) relative movement or displacement between a spring and the axle.  | Major     |
|    | (ii) relative movement or displacement between a spring and the axle which obviously affects directional stability. | Dangerous |
| f. | a missing shackle or anchor pin.  | Dangerous |
| g. | a worn slipper bracket.   | Major     |
| h. | so corroded, pitted or seriously weakened that it is likely to fail.  | Major     |
| i. | an insecure or missing locking device from a shackle or anchor pin.   | Major     |

- 3                    **Coil Spring or Torsion Bar:**
- |    |   |           |
|----|---|-----------|
| a. | (i) incomplete.   | Major     |
|    | (ii) incomplete and which obviously affects directional stability.  | Dangerous |
| b. | fractured, cracked or repaired by welding.  | Major     |
| c. | corroded, pitted or seriously weakened so it is likely to fail.   | Major     |
| d. | torsion bar fixings with excessive free play, insecure or an adjustment assembly incorrectly fitted and/or insecurely locked. | Major     |
| e. | incorrectly located or fitted.  | Major     |

# Public Service Vehicle Inspection Manual

## 48 Suspension

### **Air/Fluid Suspension Systems Valves, pipes, Valve linkage, Bellows and Displacer/Accumulator Unit:**

- |    |   |           |
|----|---|-----------|
| a. | displaced, deflated, kinked and/or so damaged/deteriorated that it is likely to fail. | Major     |
| b. | fouled by other parts.  | Major     |
| c. | with a check strap missing or defective.  | Major     |
| d. | insecure.   | Major     |
| e. | (i) leaking.  | Major     |
|    | (ii) leaking to such an extent that the function of the system is seriously affected. | Dangerous |
| f. | system inoperable.  | Dangerous |

### 5 **Bonded Suspension Unit:**

- |    |  |       |
|----|--|-------|
| a. | with failure of bonding between flexible element and metal so that part of the unit is likely to fail. | Major |
| b. | unit is so damaged or deteriorated that it is no longer capable of carrying out its proper function.   | Major |

### 6 **Shock Absorber:**

- |    |  |       |
|----|--|-------|
| a. | missing from a vehicle on which it is a standard component.  | Major |
| b. | with an anchorage fractured, unit insecure or with a sleeve damaged so that the unit is not functioning correctly. | Major |
| c. | leaking.   | Major |
| d. | with an excessively worn rubber bush or pivot.   | Major |
| e. | linkage missing, linkage bracket cracked so that it is likely to fail, fractured or cracked or excessively worn.   | Major |

**Public Service Vehicle Inspection Manual**  
**53 Axles, Stub Axles and Wheel Bearings**

**Application**

This inspection applies to the steered wheels of all vehicles.

**Procedure and Standards**

**A steered axle is** one which has a king pin or ball joints and can be turned to a left and right lock. An axle ceases being steered when it is fixed in the straight ahead position.

**When assessing excessive wear, play or king pin clearance (lift)** account must be taken of any information given below and/or manufacturers' data.

With the wheels on the ground king pin clearance is assessed between the stub axle upper yoke and beam axle using feeler gauges.

With the wheels off the ground kin pin clearance may be measured between the stub axle lower yoke and beam axle.

**For vehicles fitted with a "Hives" type thrust bearing** any clearance greater than 1.6mm would be considered excessive and in the case of any other type of bearing lift greater than 1.0mm.

**Side play in king pin and bushes.** Any movement greater than 10mm on a 500mm diameter wheel is considered excessive. For wheels of different diameter, the maximum allowable movement should be in proportion to this figure.

**Wheel bearing free play can be isolated** by applying the service brake.

**Mercedes Sprinter range of vehicles have front suspension ball joints without springs,** these joints are allowed up to 3.0 mm of axial play (lift) and 3.0 mm of radial play. Rejection is only justified when play exceeds the manufacturer's limits.

**Steered axles manufactured by BPW** have a maximum clearance of 12 mm.

**Renault Mascot vehicles** with a design weight of 3.5 to 6.5 tonnes have a maximum king pin clearance of 1.2 mm.

**Public Service Vehicle Inspection Manual**  
**53 Axles, Stub Axles and Wheel Bearings**

<b>Deficiency</b>	<b>Deficiency Category</b>
<p><b>1 Stub axle and axle:</b></p> <p>a. (i) excessive clearance between stub axle and axle beam. Major</p> <p>(ii) excessive clearance between stub axle and axle beam which obviously affects directional stability. Dangerous</p> <p>b. fractured or cracked or deformed. Dangerous*</p> <p>c. (i) inappropriate modification to an axle. Major</p> <p>(ii) unsafe modification to an axle that obviously affects stability, functionality or gives insufficient clearance to other vehicle parts or the ground. Dangerous</p>	
<p><b>2 King pin:</b></p> <p>a. (i) excessively loose in axle beam. Major</p> <p>(ii) excessively loose in axle beam which obviously affects directional stability. Dangerous</p> <p>b. king pin or bush excessively worn. Major</p> <p>c. retaining device missing or insecure. Major</p>	
<p><b>3 Swivel joint:</b></p> <p>a. (i) excessively worn. Major</p> <p>(ii) excessively worn to such an extent that directional stability is impaired. Dangerous</p> <p>b. insecure. Major</p> <p>c. retaining or locking device missing or insecure. Major</p>	
<p><b>4 Wheel bearing:</b></p> <p>(i) with excessive free play. Major</p> <p>(ii) with excessive free play which obviously affects directional stability. Dangerous</p>	

**Application**

This inspection applies to all vehicles.

**Procedure and Standards**

**A steered axle** is one which has a king pin or ball joints and can be turned to a left and right lock. An axle ceases being steered when it is fixed in the straight ahead position.

**Power steering must be inspected** with the engine running. If vehicles are fitted with additional equipment, belt driven from the engine, where the belt may cause a hazard to the inspector they should be tested without the engine running. Examples are belt driven refrigeration compressors and air conditioning.

**Exposure of structural cords on power steering hoses** is acceptable provided that these cords are not damaged.

**The hydraulic fluid level check** only applies to readily visible reservoirs which can be checked without removing the reservoir cap.

**For articulated buses** with steered wheels on the trailer and on any self steered axle, visually check joints and components for wear and condition.

**With the road wheels on the ground** rock the steering and check all steering joints and fixings.

Instruct the driver to rotate the steering wheel through its full working range. If a lock stop, which is known to be a standard fitment, is missing this is a deficiency. It should be noted however that in some cases there is provision for extra lock stops which are not a standard item. Where two are fitted only one needs to fulfil the function **on each lock**. They may be integral with the steering mechanism.

**If carrying out a steering full lock check with the wheels raised;** any steering component, road wheel or tyre fouls any part of the vehicle when the vehicle is raised but does not foul any of these items when the vehicle is on the ground under normal running conditions, this is not to be considered a deficiency.

**Vehicles with independent front suspension** should be checked with the suspension in the normal running position.

**Common means of acceptable locking devices are:**

Anti-rattle washers, split pins, lock wire, spring washers, nyloc nuts, liquid locking compounds and self locking castle type nuts.

**If a plain flat washer is used with a spring washer** the locking action of the spring washer becomes ineffective.

54 Steering

Visually check for axial and lateral movement of all ball joints. Where a ball joint is fitted with a spring to take up such movement, the compression of the spring must not be mistaken for excessive wear. If excessive wear is suspected check by using hand pressure.

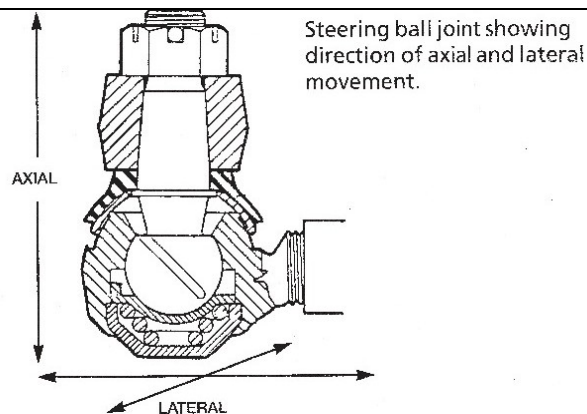

An increasing number of vehicles are now fitted with different types of ball joint, spring loaded or rubber mounted type each having different wear limits (some vehicle may be fitted with both types of joint). The rubber mounted type has a smaller wear limit than the spring loaded type.

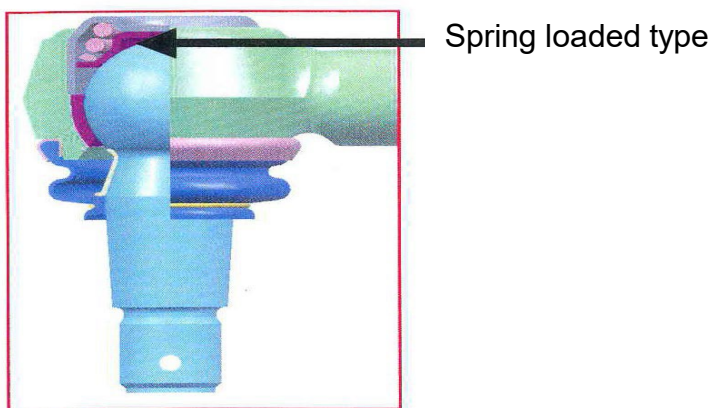
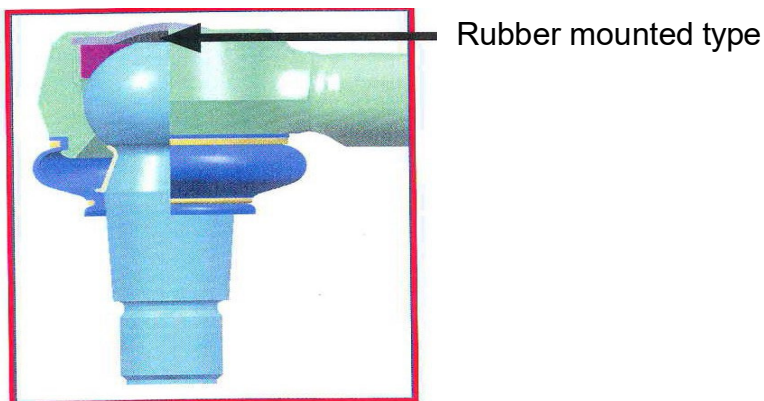

**Certain ball joints are designed only to swivel fore and aft** and not side to side (front drag link ball joints only, as fitted on the Volvo and Renault range of vehicles). In an attempt to swivel the joint you may hear a knocking sound this is normal, as this is the device to stop it swivelling. The only wear limits that should be taken into account for the annual test is axial movement. Where lateral movement is evident in the ball joint it must be confirmed that axial movement in excess of 2mm exists before a defect is justified.

**Other manufacturers with conventional ball joints** have also stated that axial movement up to 2mm is acceptable.

**Public Service Vehicle Inspection Manual**

**54 Steering**

<b>Deficiency</b>		<b>Deficiency Category</b>
1	<b>Power steering:</b>	
a.	(i) not working correctly.	Major
	(ii) not working correctly and obviously affects steering control.	Dangerous
b.	(i) removed or disconnected when a standard fitment.	Major
	(ii) removed or disconnected when a standard fitment and obviously affecting steering control.	Dangerous
c.	with an air/fluid leak from any part of the system.	Major
d.	(i) reservoir is below minimum level.	Minor
	(ii) reservoir is empty.	Major
e.	(i) pump insecure or its drive system missing or defective.	Major
	(ii) pump insecure or its drive system missing or defective and obviously affects steering control.	Dangerous
f.	(i) pipe or hose excessively corroded, damaged, bulging or fouling other parts of the vehicle.	Major
	(ii) pipe or hose excessively corroded, damaged, bulging or fouling other parts of the vehicle which obviously affects steering control.	Dangerous
g.	(i) with a cracked or damaged ram and/or ram body anchorage, any excessive free play at ram anchorage.	Major
	(ii) with a cracked or damaged ram and/or ram body anchorage, any excessive free play at ram anchorage, which obviously affects steering control.	Dangerous
h.	with excessive free play between ball and valve to the extent that separation is likely.	Dangerous
i.	(i) with cables damaged, excessively corroded.	Major
i	(ii) with cables damaged, excessively corroded to such an extent that the steering is affected.	Dangerous
j.	(i) with a system component with an inappropriate modification.	Major

# Public Service Vehicle Inspection Manual

## 54 Steering

	(ii) a system component with an unsafe modification which has seriously weakened the component, does not provide sufficient clearance to other vehicle parts or renders the steering component inoperative.	Dangerous
	k. EPS malfunction indicator lamp indicates a fault.	Major
2	<b>Steering with:</b>	
	a. (i) a ball pin shank loose.	Major
	(ii) a ball pin shank loose to such an extent that separation is likely.	Dangerous
	b. a sharp or deep groove at the neck of a ball pin.	Major
	c. (i) a track rod or drag link end insecure.	Major
	(ii) a track rod or drag link end insecure to such an extent that separation is likely.	Dangerous
	d. (i) any abnormal movement in a joint.	Major
	(ii) any abnormal movement in a joint to such an extent that separation is likely.	Dangerous
	e. (i) movement between sector shaft and drop arm.	Major
	(ii) movement between sector shaft and drop arm to such an extent that separation is likely.	Dangerous
	f. excessive wear in a pivot point (e.g. an intermediate drop arm).	Major
	g. (i) a component fixed to the chassis insecure.	Major
	(ii) a component fixed to the chassis insecure to such an extent that separation is likely.	Dangerous
	h. (i) movement between a steering arm and its fixings.	Major
	(ii) movement between a steering arm and its fixings to such an extent that separation is likely.	Dangerous
	i. a component fractured or so cracked, damaged, misaligned, deformed or so worn that it is likely to fail.	Dangerous*
	j. a retaining or locking device ineffective, not fitted or insecure.	Major

# Public Service Vehicle Inspection Manual

## 54 Steering

k.	a steering lock stop missing, insecure or not fulfilling its function.	Major
l.	(i) a component repaired by welding and or showing signs of excessive heat being applied.	Major
	(ii) a component repaired by welding and or showing signs of excessive heat being applied, which obviously affects the steering control.	Dangerous
m.	any steering component, road wheel or tyre fouling any part of the vehicle.	Major
n.	(i) track rod excessively deformed.	Major
	(ii) track rod excessively deformed and obviously affects steering control.	Dangerous
o.	roughness or undue stiffness in the operation of the steering.	Major
p.	(i) excessive lift or end float of a sector shaft.	Major
	(ii) excessive lift or end float of a sector shaft to such an extent that functionality is affected.	Dangerous
q.	(i) excessive wear in the steering rack.	Major
	(ii) excessive wear in the steering rack to such an extent that functionality is obviously affected.	Dangerous
r.	(i) excessive movement of rack housing in mounting bushes.	Major
	(ii) excessive movement of rack housing in mounting bushes to such an extent that steering control is obviously affected.	Dangerous
s.	a rack gaiter (if rack originally fitted with gaiters) split, damaged, missing or displaced.	Major
t.	(i) a ball joint cover damaged or deteriorated but not to the extent that it would no longer prevent the ingress of dirt etc.	Minor
	(ii) a ball joint cover missing, insecure, excessively damaged or severely deteriorated to the extent that it would no longer prevent the ingress of dirt etc.	Major
u.	leak of oil or grease.	Major
v.	(i) gear casing fractured.	Major

# Public Service Vehicle Inspection Manual

## 54 Steering

	(ii) gear casing fractured and obviously affects steering control or the casing is likely to become detached.	Dangerous
w.	(i) with a system component with an inappropriate modification.	Major
	(ii) a system component with an unsafe modification which has seriously weakened the component, does not provide sufficient clearance to other vehicle parts or renders the steering component inoperative.	Dangerous

# Public Service Vehicle Inspection Manual

## 57 Transmission

### Application

This inspection applies to all vehicles, including Hybrid Electric Vehicles (HEVs) and Electric Vehicles (EVs).

### Procedure and Standards

**Vehicles must be in neutral gear** and with any transmission brake released during this inspection.

**The presenter should be advised if any shaft** or carrier locking device is missing or ineffective.

**Refusal for excessive wear of a universal joint is only justified** when radial movement indicates that needle roller bearings are missing from one or more cups.

**Transmission shafts include those shafts that** transmit drive for HEVs and EVs.

**Propeller shaft spline wear** is not a deficiency.

**A power take off prop shaft universal joint** is not subject to this inspection.

**Public Service Vehicle Inspection Manual**

**57 Transmission**

<b>Deficiency</b>		<b>Deficiency Category</b>
1	<b>All vehicles with:</b>	
a.	(i) a missing or insecure propshaft flange bolt.	Major
	(ii) loose or missing propshaft flange bolts to such an extent that detachment is likely.	Dangerous
b.	(i) any flange cracked or insecure.	Major
	(ii) any flange cracked or insecure to such an extent that detachment is likely.	Dangerous
c.	(i) excessive wear in a shaft bearing.	Major
	(ii) excessive wear in a shaft bearing to such an extent that detachment is likely.	Dangerous
d.	(i) a bearing housing insecure, cracked or fractured.	Major
	(ii) a bearing housing insecure, cracked or fractured to such an extent that detachment is likely.	Dangerous
e.	(i) excessive wear in a universal joint.	Major
	(ii) excessive wear in a universal joint to such an extent that detachment is likely.	Dangerous
f.	(i) deterioration of a flexible coupling.	Major
	(ii) deterioration of a flexible coupling such that failure is imminent.	Dangerous
g.	a seriously damaged, cracked or bent shaft or a shaft which is fouling on other components.	Major
h.	(i) deterioration, fracture or insecurity of a bearing housing flexible mounting.	Major
	(ii) deterioration, fracture or insecurity of a bearing housing flexible mounting such that failure is imminent.	Dangerous
2	<b>Front wheel drive shafts with:</b>	
a.	(i) a constant velocity or universal joint excessively worn or insecure.	Major

# Public Service Vehicle Inspection Manual

## 57 Transmission

	(ii) a constant velocity or universal joint excessively worn or insecure to such an extent that failure is imminent.	Dangerous
b.	(i) a flexible coupling severely cracked, softened or breaking up.	Major
	(ii) a flexible coupling severely cracked, softened or breaking up such that failure is imminent.	Dangerous
c.	(i) a constant velocity gaiter insecure, damaged or deteriorated but not to the extent that it would no longer prevent the ingress of dirt etc.	Minor
	(ii) a constant velocity gaiter missing, insecure, excessively damaged or severely deteriorated to the extent that it would no longer prevent the ingress of dirt etc.	Major

**Application**

This inspection applies to most buses (not local service buses) with a maximum gross weight greater than 10000kg first used from 1 April 1983 or 5000kg first registered 1 May 2002. A small but significant number of buses have been approved without additional braking devices due to the engine developing sufficient retardation without the need for an additional braking device. Whether the bus requires an additional braking device will have been determined at certification and will be recorded on the technical record for the vehicle. The requirements can be confirmed by Testing and Support Services, Ellipse, Swansea.

**Procedure and Standards**

**If the device has been removed and it is mandatory** this will be a deficiency. If the device is not mandatory but is shown on the vehicles' technical record the operator should submit a notifiable alteration form VTP5 to PSV Section so that its removal can be confirmed and any reference to the device can be deleted from the vehicle record (inform the presenter using VTP57). Where an exhaust brake operating cylinder and lever are completely removed. The housing containing the butterfly may be retained with the butterfly fixed in the open position.

**Hybrid Electric Vehicles (HEVs) and Electric Vehicles (EVs)** where the power train equipment acts as a regenerative brake to comply with the additional braking requirements the unit(s) should be inspected as if it is an additional braking device. This should be marked on the technical record.

**Air leaks for operating mechanisms of hydraulic retarders or exhaust brakes** should be tested under item IM59 and only refused if the leak is affecting the braking system.

**The check of operation is made by visual assessment** to establish the likelihood of correct fitment and function, rather than to see actual operation. Refusal is justified only when it is obvious that a device is inoperative i.e. a disconnected linkage.

**Any inoperative device will be a deficiency irrespective of whether it is mandatory or not.**

**If a vehicle is fitted with an electric retarder and the warning lamp does not illuminate** when the retarder is operated, this is not a deficiency.

# Public Service Vehicle Inspection Manual

## 58 Additional Braking Devices

Deficiency	Deficiency Category
1 <b>Additional Braking Device:</b>	
a.                missing when known to be a mandatory item.	Major
b.                (i)                components missing, insecure, or damaged.	Minor
(ii)                components missing, insecure, or damaged to such an extent the device is inoperative.	Major
c.                wiring insecure or damaged to such an extent the device is inoperative.	Major
d.                with inadequate clearance with other components.	Major
e.                heat shield missing.	Major
f.                component or its surroundings overheating.	Major
g.                with exhaust gas or oil leaks from the device.	Major

**Application**

This inspection applies to all vehicles.

**Procedure and Standards**

Automatic slack adjusters must be fitted to motor vehicles first used from 1 April 1995.

**A rod or lever reduced by more than one third** of its original diameter is considered a deficiency.

**A pipe with its wall thickness reduced** by more than one third of its original thickness is considered a major or dangerous deficiency depending upon severity.

**Cables with less than 10% of the wires fractured** are not regarded as a deficiency unless there is bunching or likelihood of bunching, where the cable enters an outer cable, guide or sleeve.

**A hose should be considered a major or dangerous deficiency** for surface cracking or damage by chafing only if the reinforcement is visible.

**Repairs to metal air brake pipes by sleeving** are acceptable, providing the repair appears to be good and sound. A pipe repaired in-situ by brazing is not considered acceptable. Repairs to hydraulic brake pipes are not acceptable. Compression joints of the type using separate ferrules are not considered suitable for joints on hydraulic pressure lines.

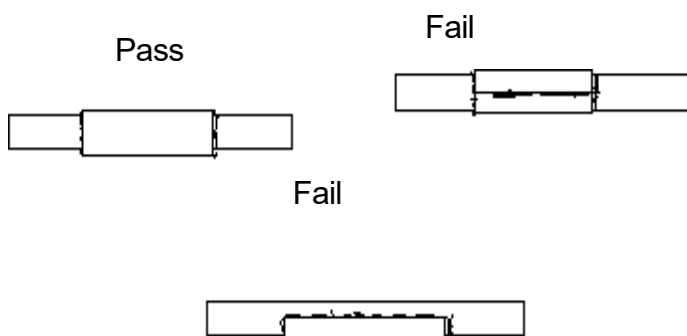

**Guidance on sleeved repairs** of metal brake pipes (sleeving is not acceptable on plastic brake pipes).

**The air pipe between the compressor and the reservoir** is to be taken as a brake pipe.

**Lever slack adjusters**; up to a total of 9.5mm radial movement at a radius of 150mm is considered acceptable within the slack adjuster and between the slack adjuster and cam cross shaft. Slack adjusters must have a secure fastening to the cross shaft including a locking device.

**Slack adjusters with different lever lengths** on the same axle are not a deficiency, but the presenter needs to be informed to complete a VTP 5 notifiable alteration form.

**Hydraulic brake callipers** are included in the term hydraulic actuators.

**Brake discs and drums**

The photos show the type of damage likely to be found on brake discs/drums and gives guidance on how much damage is acceptable before considering a deficiency. This should be a visual assessment.

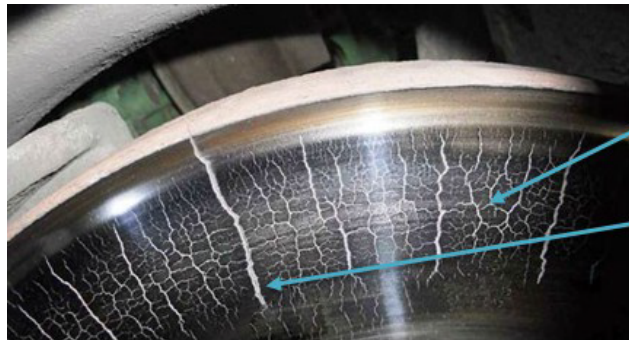

A. Unevenness in the disc surfaces <math>< 1.5\text{ mm}</math> = **acceptable**

B. Interlinked cracks or surface crazing = **acceptable**

C. A crack running from disc edge towards hub centre up to max. 75% of the width of the friction surface, and a maximum of 1.5mm wide and/or deep = **acceptable**



Brake disc fracture = **not acceptable**



Brake drum fracture = **not acceptable**

*The above photos are for reference only*

**Damp patches around valves** or adjacent components are not a deficiency. Only where there is evidence of heavy discharge of oil from the valve at the time of test should there be a defect.

**To check the condition of brake pipes** including the output side of the compressor, valves, hydraulic master & wheel cylinders it will be necessary to ask the driver to pressurise the braking systems. There is no requirement for a specific check on the operation of all valves, however where it is obvious that a valve is malfunctioning during any stage of the test, this is considered a deficiency.

**When assessing the significance of leaks**, it should be remembered that certain pneumatic components are subject to leakage to some degree.

**Vented master cylinders** as fitted in particular to some Bedford vehicles may be subject to some dampness around the vent, due to fluid in the bores of the cylinder used to lubricate the piston seals; this should not be treated as a defect.

**If spring brake actuators are fitted to the vehicle** inspect the components of this system with the park brake in the “off” position.

**BPW axles** brake calliper may have 6 holes and only 5 bolts fitted.

**Reservoirs can be repaired by welding**, the term reservoir includes accumulators and other types of vacuum & pressure vessels.

**Missing or illegible LSV plate** only applies to PSVs registered on or after 29th October 2011.

**It is not a requirement for Load Sensing Valves (LSV) to be moved** manually to check their operation. In most cases a slight movement can be detected when the service brake is applied which is sufficient evidence that the LSV is operating. Only in the minority of cases where, in the opinion of the tester, the LSV appears seized and it is the type of valve that can be checked easily by hand without the possibility of causing damage should this be carried out.

**Pre 1995 vehicle which were fitted with automatic brake slack adjusters** that have been removed and replaced with manual ones; if automatic slack adjuster brackets remain and are not being used this is acceptable.

**If a brake chamber mounting bracket is fractured and parted it** is considered insecure.

**Some manufacturers use different sizes of brake chambers in addition to the standard sizes** that have been used for many years and some manufacturers use common castings. For example a Type 22 can be made from a Type 24 casting. To avoid confusion the manufacturer fits a tag to confirm the chamber size. The first two digits are the service chamber size, if it is a spring brake the second two digits are the parking brake chamber size. This is an acceptable method of identifying chamber sizes.

**The hydraulic fluid contamination and level check** only applies to readily visible reservoirs which can be checked without removing the reservoir cap.

**There is a potential safety issue when performing a brake roller test on certain Scania vehicles fitted with a 'Halt Brake.'** The Halt Brake applies the rear axle brakes each time the foot brake is depressed, and the brake is not released until the vehicle throttle is pressed as if to drive away. If the following procedure is adopted, it should overcome the need to attempt to move the vehicle during the brake test and the possibility of having to reverse back while on the brake rollers.

First axle test as normal, then follow steps 1 – 8 for the second axle:

1. place rear wheels into brake rollers
2. apply park brake
3. ensure air pressure is at maximum
4. stop engine
5. switch off Ignition
6. release park brake
7. switch ignition on (DO NOT START ENGINE)
8. perform brake test.

There should be no effects from the "Halt Brake" at any other stage of the inspection.

**Public Service Vehicle Inspection Manual**

**59 Brake Systems and Components**

<b>Deficiency</b>		<b>Deficiency Category</b>
1	<b>A brake rod, clevis joint, linkage, relay, lever, pin, pivot, slack adjuster or cable:</b>	
a.	seriously weakened by excessive wear, corrosion, damage or reduced in diameter by more than the prescribed limit.	Major
b.	with abnormal movement indicating incorrect adjustment or excessive radial free play.	Major
c.	with an ineffective, insecure or missing locking device.	Major
d.	(i) a brake cable knotted, or with more wires broken than permitted by the specified standard.	Major
	(ii) a brake cable knotted, or with more wires broken than permitted by the specified standard which obviously affects the braking performance.	Dangerous
e.	cable guide is defective.	Major
f.	automatic slack adjuster component incorrectly installed, missing, disconnected, insecure, distorted, fractured or inoperative.	Major
g.	mandatory automatic slack adjuster not fitted.	Major
h.	a brake fitted with an automatic slack adjuster exceeding two- thirds of the travel of the brake actuator, or obviously having a different travel from another brake on the same axle, or not returning fully when brakes are released.	Major
2	<b>Brake pipes and flexible hoses:</b>	
a.	(i) misplaced and fouled or chafed by moving parts, with no obvious damage evident.	Minor
	(ii) misplaced and fouled or chafed by moving parts with obvious signs of damage.	Major

## Public Service Vehicle Inspection Manual

### 59 Brake Systems and Components

	b.	(i)	chafed, cracked with no reinforcement cords exposed, corroded, stretched or twisted.	Minor
		(ii)	excessively chafed, cracked with reinforcement cords exposed, excessively corroded, deteriorated, leaking, bulging, kinked, stretched or twisted and damage evident.	Major
		(iii)	excessively chafed, cracked with reinforcement cords exposed and damaged, excessively corroded, deteriorated, leaking, bulging, kinked, stretched or twisted and in such a condition that risk of failure is imminent.	Dangerous
	c.		inadequately clipped or otherwise inadequately supported.	Major
	d.		inadequately repaired or with unsuitable joint fittings.	Major
	e.		non-metallic pipe(s) exposed to excessive heat.	Major
	f.		leaking air from a pipe or connection.	Major
	g.		leaking hydraulic fluid from a pipe or connection.	Dangerous
	3		<b>Brake drums, back plates &amp; shoes, discs, callipers &amp; pads including friction material with:</b>	
	a.	(i)	a brake disc or drum excessively worn, or a brake disc cracked.	Major
		(ii)	a brake back plate, disc or drum in such a condition that it is seriously weakened, fractured or insecure.	Dangerous*
	b.	(i)	a brake back plate or calliper securing bolt loose or missing.	Major
		(ii)	a brake back plate or calliper securing bolts loose or missing to such an extent the back plate or calliper is insecure.	Dangerous
	c.	(i)	a brake, lining or pad less than 1.5mm thick at any point.	Major
		(ii)	a brake, lining or pad, missing, incorrectly fitted, insecure or with the lining/pad no longer visible.	Dangerous
	d.		restricted movement of a brake component.	Major
	e.	(i)	a brake drum, disc, lining or pad contaminated by oil or grease.	Major
		(ii)	a brake drum, disc, lining or pad contaminated by oil or grease with the brake performance obviously affected.	Dangerous

## 59 Brake Systems and Components

4	<b>A reservoir:</b>	
	a. (i) lightly corroded.	Minor
	(ii) insecure, excessively corroded, or leaking.	Major
	b. (i) with damage or dents that do not significantly reduce the capacity.	Minor
	(ii) with damage or dents that obviously significantly reduce the capacity.	Major
	c. with a securing strap fractured, cracked, excessively corroded or chafing on the reservoir or other mounting.	Major
	d. missing where it is known to be a standard fitting.	Major
5	<b>Actuators, hydraulic master &amp; wheel cylinders, valves &amp; servos:</b>	
	a. (i) defective in operation.	Major
	(ii) defective in operation and brake performance affected.	Dangerous
	b. (i) insecure but still operational.	Major
	(ii) insecure and brake performance affected.	Dangerous
	c. (i) leaking air or fluid, fractured, cracked, excessively damaged or corroded.	Major
	(ii) leaking air or fluid, fractured, cracked, excessively damaged or corroded and brake performance is affected.	Dangerous
	d. with a locking device missing or insecure.	Major
	e. (i) with insufficient or excessive travel of operating mechanism indicating a need for adjustment.	Major
	(ii) with insufficient or excessive travel of operating mechanism indicating a need for adjustment and brake performance is affected.	Dangerous

# Public Service Vehicle Inspection Manual

## 59 Brake Systems and Components

	f.	with a cap missing from a hydraulic master cylinder and/or fluid obviously contaminated.	Major
	g.	(i) fluid below minimum level or level warning device defective/activated.	Minor
		(ii) fluid significantly below minimum level.	Major
		(iii) no visible fluid.	Dangerous
	h.	with a valve with excessive discharge of oil.	Major
	i.	a load sensing valve removed or disconnected when it is known to be a standard fitment.	Dangerous
	j.	(i) a load sensing valve obviously seized or restricted in its free movement, linkage or brackets cracked, defective or out of adjustment (ABS functioning).	Major
		(ii) a load sensing valve obviously seized or restricted in its free movement, linkage or brackets cracked, defective or out of adjustment. (No ABS function).	Dangerous
	k.	(i) hydraulic brake actuator dust cover damaged or deteriorated but not to the extent that it would no longer prevent the ingress of dirt etc.	Minor
		(ii) hydraulic brake actuator dust cover missing, insecure, excessively damaged or severely deteriorated to the extent that it would no longer prevent the ingress of dirt etc.	Major
6		A load sensing data plate is missing or illegible.	Minor
7		<b>Air Compressor Drive:</b>	
	a.	a drive belt missing, badly deteriorated and/or so loose that it is likely to slip.	Major
	b.	a compressor drive pulley loose, cracked or missing.	Major
8	(i)	inappropriate modification to any part of the braking system.	Major
	(ii)	unsafe modification to any part of the braking system and braking performance is affected.	Dangerous

# Public Service Vehicle Inspection Manual

## 62 Reflectors and Rear Markings

### Application

This inspection of reflectors applies to all motor vehicles but only obligatory reflectors are to be checked.

Every vehicle requires two red reflectors facing to the rear.

This inspection of rear markings applies only to articulated buses. The type of marking which is acceptable is shown in the table below. The type numbers refer to the diagram on the following pages.

Overall length	Acceptable type of markings for vehicles first used before 1 April 1996	Acceptable markings for vehicles first used from 1 April 1996
More than 13m	1, 2, 3, 4, 5 or 6.	3, 4, 5 or 6.

### Procedure and Standards

A rear marker board must not be more than 10% obliterated or obstructed.

Rear markings must be fitted with the lower edge between 400mm and 1700mm from the ground.

The inspection of reflectors does not include a check that the reflectors have the appropriate approval mark. Reflective plates or tape are not acceptable as a substitute for a reflector. The check for position should be visual and only vehicles with reflectors and markings obviously out of position should be refused for this reason.

#### Rear Reflectors

The maximum height from the ground is 900mm. There are some exceptions:

- If 900mm is impractical it can be 1500mm.
- For vehicles used before 1 April 1986 and trailers manufactured before 1 October 1985 the maximum height is 1525mm.

**If less than 50% of a reflector is visible**, this is a deficiency.

**Triangular reflectors** can only be fitted to trailers and if fitted to a vehicle this is a minor deficiency under 1d.

# Public Service Vehicle Inspection Manual

## 62 Reflectors and Rear Markings

Acceptable approval marks for rear marker boards are either:

BSAU152 (types 1 – 2 below) or

'E' or 'e' (types 3 – 6 below)



Type 1



Type 3



Type 2



Type 4



Type 5



Type 6



**Application**

The inspection of front position lamps, headlamps, rear position lamps and registration plate lamps only applies to the obligatory lamps fitted.

The inspection of main beam warning lamp applies to all vehicles first used on or after 1 April 1986.

The inspection of daytime running lamps (DRLs) applies to any vehicles fitted with DRLs as original equipment first registered from 1 March 2018. Two DRLs must be fitted and no more, they must be white in colour. DRLs may not operate when the engine is not running or when the parking brake is applied. They can be manually switched off in which case they may not illuminate until the vehicle speed exceeds 10km/h or the vehicle has travelled 100m.

The inspection of stop lamps applies to any stop lamp fitted.

The inspection of end outline marker lamps applies to the obligatory marker lamps fitted to vehicles first used from 1 April 1991 which are more than 2.1m wide.

The inspection of rear fog lamps applies to any vehicle fitted with a rear fog lamp. Rear fog lamps must be fitted to vehicles first used from 1 April 1980.

Obligatory reversing lamps are required for vehicles first registered from 1 September 2009.

The inspection of front fog lamps applies to vehicles first used from 1 March 2018 where they have them fitted.

The inspection of headlamp cleaning devices applies to vehicles first registered from 1 September 2009 equipped with headlamp washers.

63 Lamps

Procedure and Standards

**Inoperative non-obligatory lamps cannot be assessed other than** the assessment of security as you cannot establish what lamp this is.

**End Outline Marker Lamps**

**The front and the rear end out line markers lamps may be** combined.

**It is not acceptable for a position light to be used** additionally as a marker lamp. A separate lamp must be fitted.

**Rear Fog Lamps**

**The rear fog lamps are permitted to be reciprocally incorporated with the rear position lamps** providing the positional requirements are met (when the fog lamp is switched on the rear position lamps intensity increases to become the fog lamp).

**Inspection of non-obligatory rear fog lamps is restricted to** a check of colour and whether operation of the brakes affects the fog lamp (deficiency 2.c).

**No more than two rear fog lamps** may be fitted.

**One or two obligatory reversing lamps must be fitted.** In addition to the obligatory lamps, vehicles up to 6m in length may have two optional lamps fitted. Vehicles over 6m in length may have up to four optional lamps (two of which may be fitted on the side of the vehicle).

**Reversing lamps must operate** automatically when reverse gear is selected or be operated by a switch with a tell-tale warning. On some vehicles, it may be necessary to have the engine running before reversing lamps will work. Where optional reversing lamps are fitted on the side of vehicles the side lamps will need to be selected as well as reverse gear.

**Rear Registration Plate Lamps**

The clear cover for the bulb is not a lens.

The registration plate lamp must be fitted in a position where it can illuminate the registration plate. A lamp fitted in a position where it cannot do this is not a registration plate lamp and this should be dealt with under deficiency 1 b.

Where more than one registration plate lamp is fitted, any one inoperative lamp is a deficiency.

**Matched Pair**, this means that the lamps emit light of the same colour; intensity and that both lamps are of the same size and are symmetrical to one another.

**If there is more than 1 bulb or LED** in the lamp at least 50% must work.

**The check for position** should be visual and only vehicles with lamps obviously out of position should be refused for this reason. A summary of the main requirements for each type of lamp is shown at the end of the application section.

**Before defecting the operation of a lamp being** affected by the operation of another lamp. The engine should be run to charge the electrical system.

**Light that bleeds through from an adjacent lamp** is acceptable provided the illuminated light lens does not change colour.

**Obscuration of lamps**, provided at least 50% of a lamp is visible this is not a deficiency.

63 Lamps

If two or more lamps are fitted and the aggregated illuminated area occupies 60% or more of the area of the smallest rectangle circumscribing the illuminated area this should be treated as one lamp.

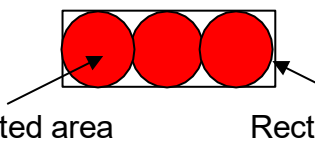

Gas discharge lamps, blue tint bulbs and lamps with neutral colour lenses are acceptable providing when lit the light emitted is white or; if it is a direction indicator is amber or in the case of a stop lamp red.

Vehicles equipped with dim dip require the front position lamps to be checked for operation with the ignition switched off.

HID Lamps may be identified by:

- taking a few seconds to reach full intensity
- having a bluish tinge to the light
- having an igniter module/inverter behind the headlamp
- having 'DCR' marked on the headlamp lens or body.

HID headlamps use high voltage and extra care should be taken when inspecting these items.

A summary of the main requirements for each type of lamp is shown below.

TYPE	DATE OF FIRST USED	POSITION			COLOUR
		MAX DISTANCE FROM SIDE (MM)	MAX HEIGHT (MM)	MINIMUM HEIGHT (MM)	
Front Position Lamps	From April 1986	400	-	-	White or yellow if in a headlamp which shows yellow light
	Before April 1986	510	-	-	
Front End Outline Marker Lamp	From April 1991	400	-	The top of the lamp shall be no lower than the top of the windscreen	White
Dipped Beam Headlamp	From 1972 (refer to Lighting regulations for earlier vehicles)	400 Being a matched pair	1200	500	White or Yellow

**Public Service Vehicle Inspection Manual**

**63 Lamps**

Main Beam Headlamp	From 1931	-	-	-	White or Yellow
Rear Position Lamps	From April 1986	400	1500 or if impracticable 2100	350	Red
	Before April 1986	800	2100	-	
Rear End Outline Marker Lamps	From April 1991	400	-	As high as possible with regard to the lateral position, and the use for which the vehicle is constructed	Red
Stop Lamps	From 1971 (refer to Lighting regulations for earlier vehicles)	One on each side with a minimum separation distance of 400mm	1500 or if impracticable 2100	350	Red
Rear Registration Plate Lamp	All vehicles	-	-	-	White
Rear Fog Lamp	From April 1980	Where one lamp is fitted: On centre line or offside of vehicle.	1200	250	Red
Front Fog Lamp	From March 01 2018	400	1200 No higher than the dipped beam lamps	250	White or Yellow
Reversing Lamps	From September 01 2009	-	1200	250	White
Optional Day Time Running lamps	From March 01 2018	400	1500	250	White

**Public Service Vehicle Inspection Manual**

**63 Lamps**

Deficiency	Deficiency Category
<p><b>1</b>                    <b>For all lamps:</b></p> <p>a.    (i) any lamp insecure but unlikely to become detached.</p> <p>         (ii) any lamp insecure and likely to become detached.</p> <p>b.            an obligatory lamp missing or inoperative.</p> <p>c.    (i) an obligatory lamp dim due to dirt or internal deterioration or with a partially reduced light output.</p> <p>         (ii) an obligatory lamp dim due to dirt or internal deterioration or with an obvious major reduction in light output.</p> <p>d.    (i) an obligatory lamp lens obscured partially, insecure, or damaged but not likely to fall apart.</p> <p>         (ii) a obligatory lamp lens missing, obscured, insecure and or damaged so it is likely to fall apart.</p> <p>e.    (i) an obligatory lamp not showing a light of the right colour.</p> <p>         (ii) an obligatory lamp not showing a light of the right colour with red light shown to the front or white light shown to the rear.</p> <p>f.            an obligatory lamp incorrectly positioned.</p> <p>g.            an obligatory lamp is affected by the operation of any other lamp.</p>	<p>Minor</p> <p>Major</p> <p>Major</p> <p>Minor</p> <p>Major</p> <p>Minor</p> <p>Major</p> <p>Minor</p> <p>Major</p> <p>Major</p> <p>Major</p>
<p><b>2</b>                    <b>Rear Fog lamp:</b> (in addition to 1 above)</p> <p>a.            tell-tale not fitted, not working or cannot be seen by the driver.</p> <p>b.            more than two rear fog lamps are fitted.</p> <p>c.            non obligatory rear fog lamp(s) affected by the operation of the foot brake and or shows the incorrect colour.</p>	<p>Major</p> <p>Major</p> <p>Major</p>
<p><b>3</b>                    <b>Stop lamps:</b> (in addition to 1 above)</p> <p>a.            Any stop lamp not showing a steady red light when the brakes are applied.</p> <p>b.            No stop lamps show a steady red light when the brakes are applied, or all lamps do not go out when the brakes are released.</p>	<p>Major</p> <p>Dangerous</p>

# Public Service Vehicle Inspection Manual

## 63 Lamps

4	<b>Headlamp:</b> (in addition to 1above)	
a.	not forming part of a matched pair.	Major
b.	not positioned symmetrically in relation to the other lamp.	Major
c.	one of a matched pair does not show a light of the same intensity and colour as the other.	Major
d.	a main beam headlamp cannot be switched off by operating one switch which at the same time leaves a pair of dipped beams.	Major
e.	main beam warning lamp does not illuminate when main beam is selected and extinguish when dipped beam is selected.	Major
f.	(i) cleaning device inoperative.	Minor
	(ii) cleaning device inoperative for LED or gas discharge (HID) systems.	Major
5	A rear registration plate lamp (in addition to 1 above) throws direct light to the rear.	Major
6	Front fog lamp (in addition to 1 above) inoperative.	Major
7	<b>Reversing lamp (in addition to 1 above):</b>	
a.	does not operate automatically when reverse gear is selected.	Major
b.	more than two (vehicles up to 6m in length) or four (vehicles over 6m in length) optional reversing lamps fitted.	Major
8	<b>Day Time Running Lamp (in addition to 1 above):</b>	
a.	not showing a light of the right colour.	Minor
b.	not showing a light of the right colour with red light shown to the front or white light shown to the rear.	Major
c.	incorrectly positioned.	Major

**Public Service Vehicle Inspection Manual**  
**66 Direction Indicators and Hazard Warning Lamps**

**Application**

The inspection of indicators applies to all vehicles first used after 1 January 1936.

Side repeaters are required on vehicles first used from 1 April 1986.

This inspection applies to all vehicles fitted with hazard warning lamps. They need not be fitted to vehicles first used before 1 April 1986.

**Procedure and Standards**

**Direction indicators**

**All indicators fitted must be inspected. These must show amber light unless** fitted to a vehicle first used before 1 September 1965 when both indicators may show white to the front or red to the rear.

**The tell-tale on direction indicators may be audible rather than visual but** for hazard warning lamps it must be a flashing light. A tell tale is not required if the operation of one or more indicators on each side can be seen from the driver's seat.

**If the flash rate is below 60 times per minute**, recheck with the engine running.

**A semaphore indicator is acceptable.** It must illuminate when in operation and is not required to flash.

**Hazard warning lamps**

The tell-tale must be a flashing light and operate with the ignition on and off. Alternatively, direction indicator tell-tales that otherwise operate independently can be accepted as the hazard warning lamp tell-tale.

**Where red neutral direction indicator lenses** with an amber bulb are fitted, the assessment made must be against the colour of the light emitted not the colour of the lens.

**Some vehicles are fitted with side indicator lamps combined with side marker lamps.** There are numerous combinations of these lamps all dependant on the vehicle type, age, length and mixtures of mandatory and optional arrangements.

All the indicators and side marker lamps on one side may flash when an indicator is selected and on other vehicles any combination of static and flashing lamps may be illuminated. Where a marker lamp remains static when the indicator is switched on this shall not be a deficiency as long as the vehicle has one operational side indicator each side within 2.6m of the front of the vehicle.

It can be difficult under these circumstances to confirm if there is a side indicator lamp combined with the side marker lamp unless it operates when selected. If the lamp flashes when the indicator is selected it must be assessed against all the appropriate standards for an indicator. Where the lamp does not flash when selected the lamp shall not be deemed to be a side indicator lamp.

**If two or more lamps are fitted** and the aggregated illuminated area occupies 60% or more of the area of the smallest rectangle circumscribing the illuminated area this should be treated as one lamp.

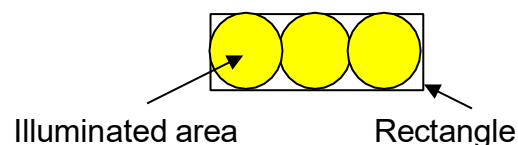

**If more than one bulb or LED** is fitted in the lamp at least 50% must work.

**Public Service Vehicle Inspection Manual**  
**66 Direction Indicators and Hazard Warning Lamps**

**Inoperative non-obligatory lamps cannot be assessed** as you cannot establish what lamp this is (insecure non obligatory lamps are a deficiency in IM63).

<b>Deficiency</b>	<b>Deficiency Category</b>
<p><b>1</b>                    <b>Direction indicator:</b></p> <p>a.                    missing, inoperative, operating on the wrong side of a vehicle, not visible either to the front, side, or to the rear.                    Major</p> <p>b.                    (i)                    a lamp dim due to dirt or internal deterioration or with partially reduced light output.                    Minor</p> <p>                          (ii)                    a lamp dim due to dirt or internal deterioration or with an obvious major reduction in light output.                    Major</p> <p>c.                    (i)                    lens insecure or damaged with no effect on light output.                    Minor</p> <p>                          (ii)                    lens missing, insecure or damaged so that it is likely to fall apart to such an extent that light output is obviously affected.                    Major</p> <p>d.                    does not flash at between 60 to 120 times a minute.                    Major</p> <p>e.                    does not show a light of the right colour.                    Major</p> <p>f.                    tell-tale not fitted, is inoperative or cannot be seen/heard by the driver.                    Major</p> <p><b>2</b>                    <b>Hazard warning lamp:</b></p> <p>a.                    does not operate with the engine stopped and the ignition switched off and on.                    Major</p> <p>b.                    all the direction indicator lamps do not operate simultaneously when switched on by one switch.                    Major</p> <p>c.                    tell-tale not fitted, is inoperative or cannot be seen by the driver.                    Major</p>	

**Application**

The headlamp aim criterion is applicable to all dipped beam headlamps.

**Procedure and Standards**

**Headlamp beam converters fitted to right hand dipping headlamps** which effectively mask/deflect the beam are acceptable provided that the pass criteria are met.

**PSVs are normally presented for test in an unladen condition.** If a drivers cab mounted headlamp adjustment device is fitted, it must be set appropriately for this state — typically in the “zero” position and not moved from this position to alter the aim. Any other adjustments made directly to the headlamps will be treated as a deficiency.

In all other circumstances, the drivers cab device may be used to adjust the headlamps so that both comply with the required criteria; however, both headlamps must still meet the standards with the device set in a single position.

**Most modern vehicles are fitted with European headlamps.** Dipped beam headlamps can be identified from the marking on the lamps. There will be a "C" shown above an "E" or "e" mark.

**If the beam pattern is blurred due to condensation** and does not show a distinctive cut-off point for the examiner to determine whether the alignment is correct this will be considered a deficiency under number 2.

In all cases, PSVs first used before 1 October 1969 are only required to have the beam checked to see that it does not cause undue dazzle or discomfort to other road users. These vehicles must be tested non-electronically.

**Some vehicles with complex headlamp systems** (with the dipped beam and main beam having separate pockets) may be encountered. It is essential that the headlamp aim test equipment is aligned exactly on the centre of the dipped beam pocket. At this point it may not be possible to see a clearly defined headlamp pattern, to see the full beam pattern, it may be necessary to move the vehicle closer to the test equipment. Once this has been done, the beam pattern should be clearly visible on the aiming screen. When a full pattern can be seen, the normal assessment of headlamp aim should be followed.

The standards to be applied are listed in the deficiency column and the beam patterns likely to be encountered are shown on the following pages.

67 Aim of Headlamps

**European checked on Dipped Beam**

Align the headlamp aim testing equipment to the vehicle in accordance with the manufacturer's instructions.

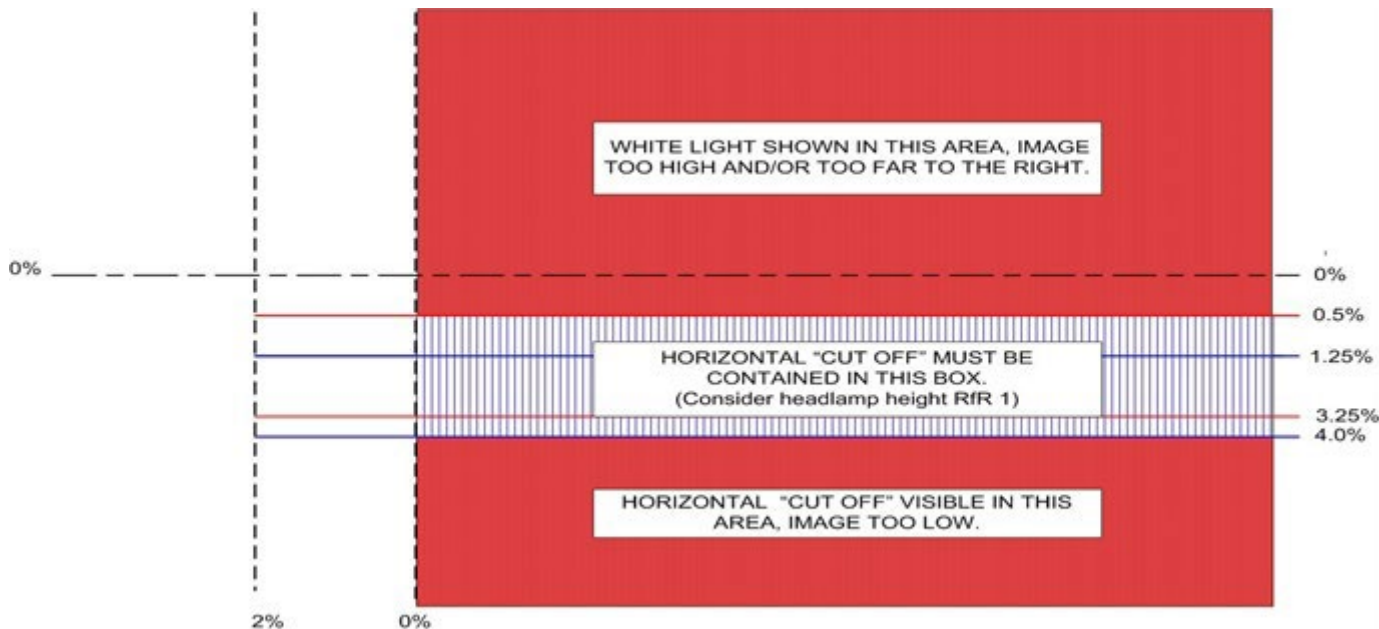

**British American Checked on Dipped Beam**

Align the headlamp aim testing equipment to the vehicle in accordance with the manufacturer's instructions.

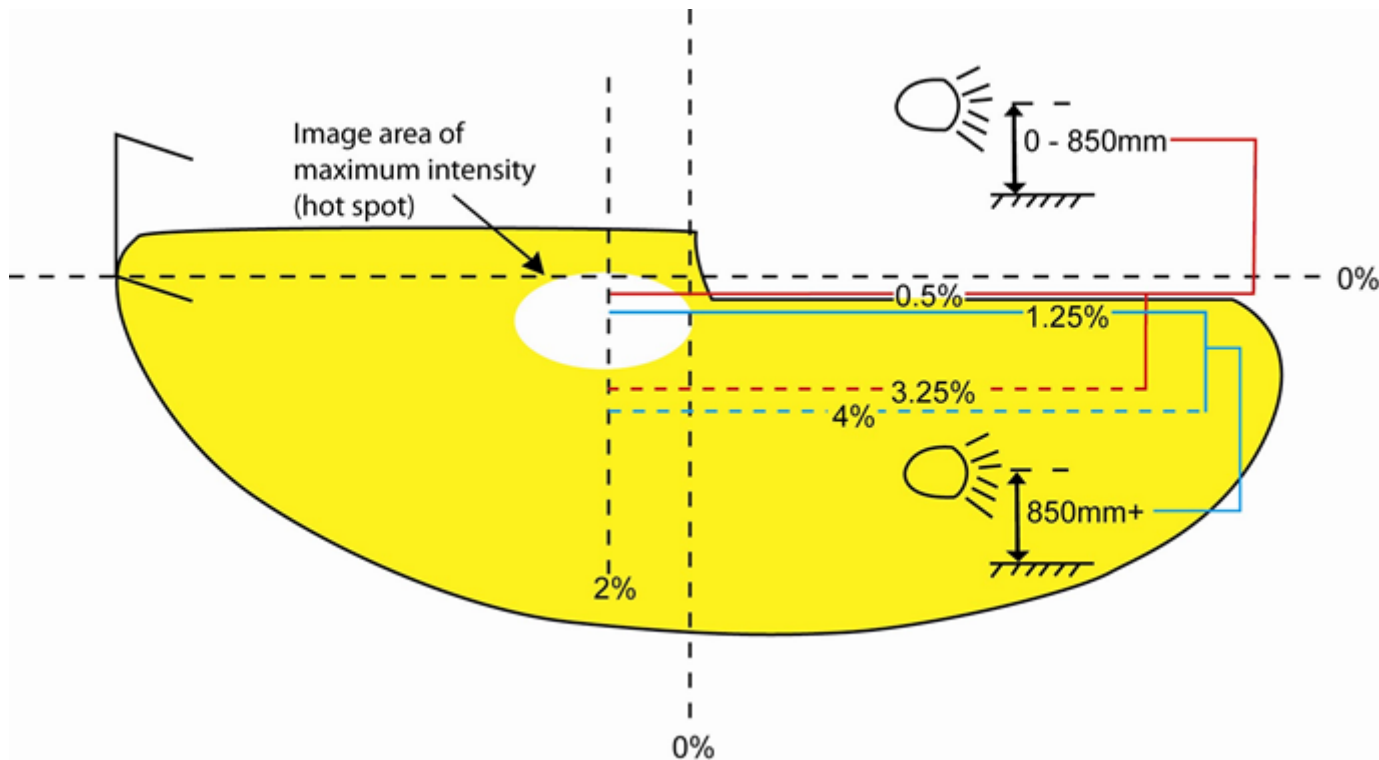

**British American Checked on Main Beam**

Align the headlamp aim testing equipment to the vehicle in accordance with the manufacturer's instructions.

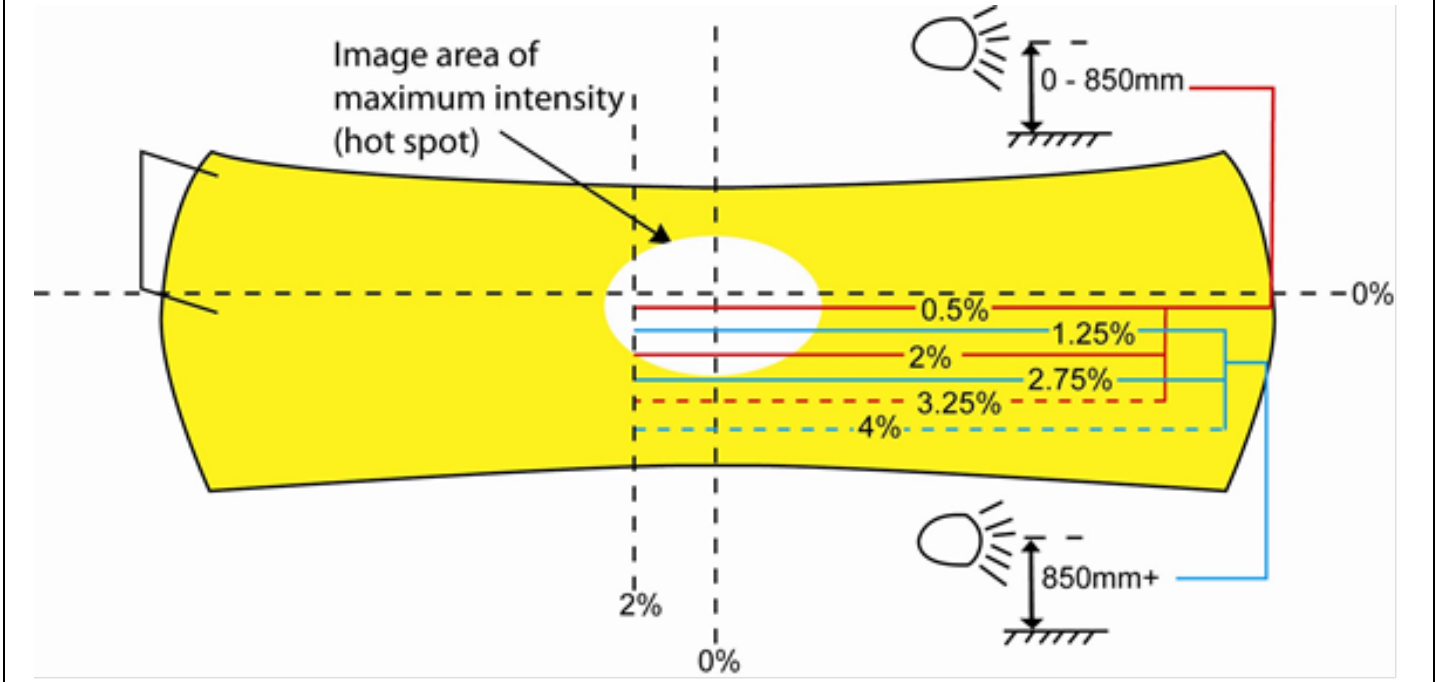

# Public Service Vehicle Inspection Manual

## 67 Aim of Headlamps

Deficiency	Deficiency Category
<b><u>European checked on Dipped Beam:</u></b>	
<p>1 In relation to the 0% horizontal line, the beam horizontal cut-off line is not between the limits listed below.</p> <p>a. <b>Headlamp centres up to and including 850mm high</b> Upper limit: All vehicles. 0.5% Lower limit: All vehicles 4.0%</p> <p><b>Headlamp centres over 850mm high</b> Upper limit: All vehicles. 1.25% Lower limit: All vehicles 4.0%</p> <p>b.</p>	Major
2 The beam image contains a “Kick up” that is not visible on the screen.	Major
3 White light shows in the zone formed by the 0% vertical and 0.5% horizontal lines.	Major
<b><u>British American Checked on Dipped Beam:</u></b>	
<p>4 In relation to the 0% horizontal line, <b>the upper edge</b> of the “Hot Spot” is not between the limits listed below.</p> <p><b>All headlamp heights</b> Upper limit: All vehicles. 0% Lower limit: All vehicles 4.0%</p>	Major
5 The right hand edge of the “Hot Spot” is to the right of the vertical 0% line, or more than 2% to the left of it.	Major
6 A headlamp dips to the right (see note in Applications).	Major
<b><u>British American Checked on Main Beam:</u></b>	
<p>7 In relation to the 0% Horizontal line, <b>the centre</b> of the “Hot Spot” is not between the limits listed below.</p> <p>a. <b>Headlamp centres up to and including 850mm high</b> Upper limit: All vehicles. 0% Lower limit: All vehicles. 2.0%</p> <p><b>Headlamp centres over 850mm high</b> Upper limit: All vehicles. 0% Lower limit: All vehicles. 2.75%</p>	Major

# Public Service Vehicle Inspection Manual

## 67 Aim of Headlamps

b.

8	In any case, the centre of the "Hot Spot" is to the right of the vertical 0% line or more than 2% to the left of it.	Major
9	A headlamp dips to the right (see note in Applications).	Major

# Public Service Vehicle Inspection Manual

## 71 Service Brake Performance

### Application

This inspection applies to all vehicles.

### Procedure and Standards

**To avoid damage to the vehicle or the equipment**, no tyre must be obviously underinflated.

**Articulated buses** should be treated as one vehicle.

**In this section of the manual, the term "drum"** includes "discs".

Attention must be paid to Hybrid Electric Vehicles (HEVs) and Electric Vehicles (EVs). Due to the nature of the control systems some vehicles cannot be tested on the Roller Brake Tester and must receive a decelerometer brake test.

Some vehicles have a regenerative braking system connected to the service brake system. If the regenerative system cannot be disconnected from the service brake, a decelerometer brake test is required. If the regenerative system can be disconnected and the vehicle control system allows a roller brake test this must be carried out.

If you are in any doubt whether a vehicle can be roller brake tested, if the presenter does not know contact T.S.S. Swansea.

Brake testing HEVs and EVs, with a regenerative brake system must be appropriately charged (appropriately in this context means the warning light is not illuminated).

**Vehicles that require decelerometer testing are:**

Any vehicle where regenerative braking cannot be disconnected.

**Vehicles that can be tested on the brake rollers are:**

Alexander Dennis – There is a switch which needs to be turned off, instruct the driver to do it.

Optare Solo EV, HEV, Versa EV and Versa HEV – Transmission in neutral with ignition off.

Wrights – Ensure the vehicle is in neutral.

**Before defecting a vehicle for binding**, examiners should be aware that drag at a wheel may be recorded which is not necessarily due to brakes, but may be due to transmission drag, or by the deformation of the tyres on the rollers, which on a fully laden 10,000 kg axle could be as much as 250kg. A recorded bind in excess of 4% of the measured axle weight should be considered a deficiency.

**Brake effort fluctuation of more than 70%** of the higher brake effort recorded at a steady pedal pressure is a deficiency. For ease of calculation if the higher brake effort divided by the lower brake effort is greater than 3.3 this is a deficiency.

**The highest reading obtained should be recorded** when the brake force from any one wheel is fluctuating in a regular manner between two readings, (eg, 1850kg should be recorded where the needle reading was fluctuating between 1750kg and 1850kg).

**Using the maximum recorded forces for each wheel on an axle**, check that the braking effort from any wheel is 70% or more of the effort of the other wheel on the same axle. When wheels lock, this deficiency will not apply if both the wheels lock, or if one wheel locks and the braking effort of the locked wheel is less than that of the other.

**No braking effort recorded at any wheel is a dangerous deficiency. Little brake effort recorded at any road wheel** should be considered a deficiency if less than 5% of the measured axle weight is not attained.

**If more than half the number of wheels lock**, the specified brake effort can be considered to be met. Wheels on the verge of locking are not acceptable, they must fully lock.

**If the vehicle cannot be roller brake tested**, or for any other reason a decelerometer test is required, proceed as per the instruction at the end of this section.

**If drop off of brake effort is noted during the roller brake test**, first confirm that it is drop off and not simply due to the driver releasing the brake pedal or brake effort fluctuation. If drop off is confirmed it will be appropriate to consider a deficiency under Inspection Manual item 59.

#### **Vehicles with full power hydraulic braking systems**

If necessary to confirm compliance with IM 34 for vehicles with full powered hydraulic braking systems the following additional tests should be made:

- Position the vehicle so that each axle in turn is located on the roller brake tester.
- With the engine stopped, deplete the brake pressure by repeated application of the service brake pedal until commencement of operation of the low pressure warning device.
- With the roller brake test machine driving the wheels of each axle in turn;
  - a. apply the service brake slowly and check for first indications of braking effort. Release brake immediately. Repeat for three further occasions.
  - b. repeat test sequence for each axle in turn.

**For vehicles with Hydrostatic drives** if the brake performance is not met on the brake rollers, perform a decelerometer test before making a decision on the test standard. Prior to roller brake testing any vehicle with hydrostatic drive and a transmission parking brake it may be necessary when the wheels are in the roller set to select the vehicles mode which disengages/bypasses the hydrostatic drive. Engaging this mode will prevent any hydrostatic retardation showing as excessive levels of bind.

**Switching the ignition off on vehicles equipped with EBS** is to be taken as the same as vehicles having their LSV disconnected.

<b>PSV SERVICE BRAKE EFFICIENCY REQUIREMENTS</b>			
First used	First used before 1 January 1968	First used from 1 January 1968 and before the 1 April 1982	Any other vehicle
Specified Efficiency	45% of Calculated Gross Vehicle Weight	50% Calculated Gross Vehicle Weight	50% Design Gross Vehicle Weight

**PSVs are presented unladen and tested as presented.**

The brake force requirements for each individual vehicle can be normally found on the PSV technical prints, from the Computer technical records or from Technical Support Service at Swansea.

**Computer controlled brake tests automatically test unladen PSVs using the following:**

The braking performance is established in one of three ways depending on the number of wheels which lock during the roller brake test.

1. If more than half the number of wheels lock, the specified brake efficiency can be considered met. Wheels on the verge of locking are not acceptable, they must fully lock.
2. One or more up to and including half wheels lock - efficiency calculated against presented weight (Unladen Weight ULW) as measured by the RBT.
3. No wheels locks - efficiency calculated against Calculated Gross Vehicle Weight\*/Design Gross weight.

**\*Calculated Gross Vehicle Weight (CGVW)** is found by using the formula:

$$CGVW = X + (Y+Z) \text{ where:}$$

- X is the unladen weight (as stated on the side of the bus).
- Y is the number of passengers the bus is constructed to carry in addition to the driver/crew (total number of seats).
- Z is the number of standing passengers the bus is constructed to carry.

Passenger/driver/crew weights are calculated using:

pre: 01.04.1988 = 63.5kg

post: 01.04.1988 = 65kg (where vehicle has exterior luggage space add 10kg per passenger)

**Roller Brake Test Machines Operating With a Computer Controlled Brake Test**

Follow the sequence of instructions as displayed and prompted on screen. On completion of the test a result sheet is printed indicating the test result.

**Roller Brake Test Machines Not Operating With a Computer Controlled Brake Test**

- a. check no brake on any wheel is binding.
- b. apply brake slowly and check for abnormal time lag in operation of the brake on any wheel.
- c. on a (vehicle) steered axle with the service brake applied at a steady pedal pressure, check there is no indication of brake effort fluctuations regularly with each revolution of the road wheel.
- d. continue to apply the brake until the road wheel is just at the point of slip relative to the rollers, or until the service brake is fully applied, whichever occurs first. Note the maximum recorded brake effort.

# Public Service Vehicle Inspection Manual

## 71 Service Brake Performance

### Decelerometer test.

Set the decelerometer on the vehicle in accordance with the instrument manufacturer's instructions. At a speed of approximately 20mph, have the service brake applied, note the reading on the decelerometer and whether the vehicle deviates from a straight line.

Deficiency	Deficiency Category
<p>1</p> <p><b>All Roller Brake Test Machines:</b></p> <p>a. A brake on any wheel binding.</p> <p>b. Brake mechanism on any wheel sticking, indicated by an abnormal time lag before an increased reading is obtained.</p> <p>c. With service brake applied at a steady pedal pressure, the indication of brake effort fluctuates regularly with each revolution of the road wheel, on a steered axle, so much that the ovality of any brake drum is obvious. A fluctuation of recorded reading in excess of 70%, between highest and lowest indicated readings is to be considered a deficiency.</p> <p>d. <b>With the service brake fully applied:</b></p> <p>(i) there is very little brake effort at any wheel.</p> <p>(ii) there is no brake effort at any wheel.</p> <p>(iii) braking effort from any wheel on an axle is less than 70% of the brake effort from another wheel on the same axle.</p> <p>(iv) braking effort from any wheel on an axle is less than 50% of the brake effort from another wheel on the same axle in the case of steered axles.</p> <p>(v) the specified brake effort is not met.</p>	<p>Major</p> <p>Major</p> <p>Major</p> <p>Major</p> <p>Dangerous</p> <p>Dangerous*</p> <p>Dangerous*</p>
<p>2</p> <p><b>Decelerometer test:</b></p> <p>a. the braking efficiency recorded by decelerometer is below the specified efficiency.</p>	<p>Major</p>

**72 Secondary Brake Performance**

**Application**

This inspection applies to all vehicles where the designated secondary brake operates independently of the service brake.

On vehicles where the service brake split system is designated as the secondary option the performance of this brake is not required to be assessed. Any brake test printout indicating failure to meet the secondary requirements must be overruled along with any prompts for an alternative option.

For vehicles where the brake code is unknown or incorrect the park brake system must be selected as the secondary option and the secondary brake efficiency tested accordingly.

**Procedure and Standards**

**To avoid damage to the vehicle or the equipment**, no tyre must be obviously under inflated.

Where a designated secondary (using the park brake system) fails to meet the specified efficiency the service brake split system must be considered as an alternative as and where it applies.

Where the service brake split system is unknown the alternative secondary brake must be assessed using a front to rear split as the alternative option (see table below).

Front to Rear Split Allocation		
Number of vehicles axles	Front split	Rear split
2 axle	1	2
3 axle	1	2+3

**Both halves of the split system must** meet the secondary efficiency requirement independently.

The notes relating to Electrical and Hybrid Electrical Vehicles under Inspection 71 also apply to this inspection particularly where the designated secondary brake is the parking brake, refer to these notes before deciding what type of brake test should be performed.

**The notes relating to locked wheels, little/no braking effort, balance decelerometer testing and articulated buses** under Inspection 71 also apply to this inspection.

72 Secondary Brake Performance

PSV SECONDARY BRAKE EFFICIENCY REQUIREMENTS			
First used	First used before 1 January 1968	First used from 1 January 1968 and before the 1 April 1982	Any other vehicle
Specified Efficiency	20% Calculated Gross Weight	25% Calculated Gross Vehicle Weight	25% Design Gross Vehicle Weight

**PSVs are presented unladen and tested as presented.**

The brake force requirements for each individual vehicle can be normally found on the PSV technical prints, from the Computer technical records or from Technical Support Service at Swansea.

**Computer controlled brake tests automatically test unladen PSVs using the following:**

The braking performance is established in one of three ways depending on the number of wheels which lock during the roller brake test.

1. If more than half the number of wheels lock, the specified brake efficiency can be considered met. Wheels on the verge of locking are not acceptable, they must fully lock.
2. One or more up to and including half wheels lock - efficiency calculated against presented weight (Unladen Weight ULW) as measured by the RBT.
3. No wheels locks - efficiency calculated against Calculated Gross Vehicle Weight\*/Design Gross weight.

**\*Calculated Gross Vehicle Weight (CGVW)** is found by using the formula:

$$CGVW = X + (Y+Z) \text{ where:}$$

- X is the unladen weight (as stated on the side of the bus).
- Y is the number of passengers the bus is constructed to carry in addition to the driver/crew (total number of seats).
- Z is the number of standing passengers the bus is constructed to carry.

Passengers/driver/crew weights are calculated using:

pre: 01.04.1988 = 63.5kg

post: 01.04.1988 = 65kg (where vehicle has exterior luggage space add 10kg per passenger)

**Public Service Vehicle Inspection Manual**

**72 Secondary Brake Performance**

Deficiency	Deficiency Category
<p><b>1 All Roller Brake Test Machines</b></p> <p><b>With the secondary brake fully applied:</b></p> <p>a. (i) there is very little braking effort at any wheel equipped with a brake operated by the secondary brake system.</p> <p>(ii) there is no braking effort at all on any wheel equipped with a brake operated by the secondary brake system.</p> <p>b. (i) braking effort from any wheel on an axle is less than 70% of brake effort from another wheel on the same axle.</p> <p>(ii) braking effort from any wheel on an axle is less than 50% of brake effort from another wheel on the same axle in the case of steered axles.</p> <p>c. the specified brake effort is not met.</p>	<p>Major</p> <p>Dangerous</p> <p>Major the</p> <p>Dangerous* the</p> <p>Dangerous*</p>
<p><b>2 Decelerometer test:</b></p> <p>a. the braking efficiency recorded by decelerometer is below the specified efficiency.</p> <p>b. the vehicle deviates appreciably from a straight line.</p>	<p>Major</p> <p>Major</p>

73 Parking Brake Performance

**Application**

This inspection applies to all vehicles First used from 1 January 1968.

The notes relating to Electrical and Hybrid Electrical Vehicles under Inspection 71 also apply to this inspection particularly where the designated secondary brake is the parking brake, refer to these notes before deciding what type of brake test should be performed.

**Procedure and Standards**

**To avoid damage to the vehicle or the equipment**, no tyre must be obviously under-inflated, and the brake rollers should not be continuously applied.

**The parking brake is tested against an applied brake**, except for vehicles with transmission parking brakes, or if the R.B.T. is not capable of carrying out an applied test. In these cases, it is necessary to progressively apply the park brake against each wheel in turn except with a transmission brake where it will be applied progressively with both wheels turning, releasing the brakes where there any signs of severe judder or snatch.

**There may be occasions where the specified brake effort is met but**, if the brake effort from any wheel on an axle is one third or less than the brake effort from another wheel on the same axle, it may be necessary to consider deficiency 1b or 5a of section 59 depending on the operating system (e.g. cable, rods, air or hydraulic).

**The notes relating to locked wheels, little/no braking effort, balance, decelerometer testing and articulated buses** under Inspection 71 also apply to this inspection.

73 Parking Brake Performance

PSV PARKING BRAKE EFFICIENCY REQUIREMENTS			
First used	First used before 1 January 1968	First used from 1 January 1968 and before the 1 April 1982	Any other vehicle
Specified Efficiency	No requirement	16% Calculated Gross Vehicle Weight	16% Design Gross Vehicle Weight

**PSVs are presented unladen and tested as presented.**

The brake force requirements for each individual vehicle can be normally found on the PSV technical prints, from the Computer technical records or from Technical Support Service at Swansea.

**Computer controlled brake tests automatically test unladen PSVs using the following:**

The braking performance is established in one of three ways depending on the number of wheels which lock during the roller brake test.

1. If more than half the number of wheels lock, the specified brake efficiency can be considered met. Wheels on the verge of locking are not acceptable, they must fully lock.
2. One or more up to and including half wheels lock - efficiency calculated against presented weight (Unladen Weight ULW) as measured by the RBT.
3. No wheels locks - efficiency calculated against Calculated Gross Vehicle Weight\*/Design Gross weight.

**\*Calculated Gross Vehicle Weight (CGVW)** is found by using the formula:

$$CGVW = X + (Y+Z) \text{ where:}$$

- X is the unladen weight (as stated on the side of the bus).
- Y is the number of passengers the bus is constructed to carry in addition to the driver/crew (total number of seats).
- Z is the number of standing passengers the bus is constructed to carry.

Passengers/driver/crew weights are calculated using:

pre: 01.04.1988 = 63.5kg

post: 01.04.1988 = 65kg (where vehicle has exterior luggage space add 10kg per passenger)



# Public Service Vehicle Inspection Manual

## 74 Other Dangerous Defects and Conditions

### Application

This applies to all vehicles.

### Procedure and Standards

Whilst this manual attempts to be comprehensive and cover all deficiencies which could be dangerous, it is inevitable that due to changes in design, maintenance practices, or other reasons, dangerous defects or conditions may be found which are not described in any of the deficiencies in the other items in this manual.

If a defect or condition of this type is found, which is such that the use of the vehicle on the road would involve an immediate danger of injury to any person, this would justify a defect under this section. In addition, it would be appropriate to issue an Immediate Prohibition for a deficiency of this nature.

This section is not intended to be used routinely, but only for exceptional cases. If a deficiency is recorded under this section, full details must be shown on the test refusal, and a copy should be sent to Testing and Support Services so that any trends can be noted and amendments made to the manual if necessary.

#### Examples of applicable conditions include:

- Tools or equipment (e.g. bottle jacks, ratchets, spanners) inadvertently left on or under a vehicle, or near suspension, braking, or steering components that can fall, interfere with components of the vehicle or pose an immediate risk to other road users.
- Foreign objects or temporary items left on, under, or in any unsecured position on the vehicle where they can fall, interfere with components of the vehicle or pose an immediate risk to other road users.

### Deficiency

### Deficiency Category

1	A defect or condition not described elsewhere in the manual such that the use of the vehicle on the road would involve an immediate danger of injury to any other person.	Dangerous
---	---	-----------