

# GENERIC SCHEME ENERGY FLOW DIAGRAMS

These diagrams may be used to support submissions for Simple Schemes where they are appropriate to the Scheme. Ensure that locations of sensors and meters are clearly identified on the diagram. This is particularly relevant where the engine is not on the CHPQA Unit List. The diagrams may also be utilised for Schemes submitting using the Complex journey, but the diagram must be amended to suit the Scheme Line Diagram and Energy Flow Diagram requirements, and also to remove information that is not pertinent to the Scheme in question.

## Reciprocating Engine CHP providing Hot Water Heat Output with No Heat Rejection Facility

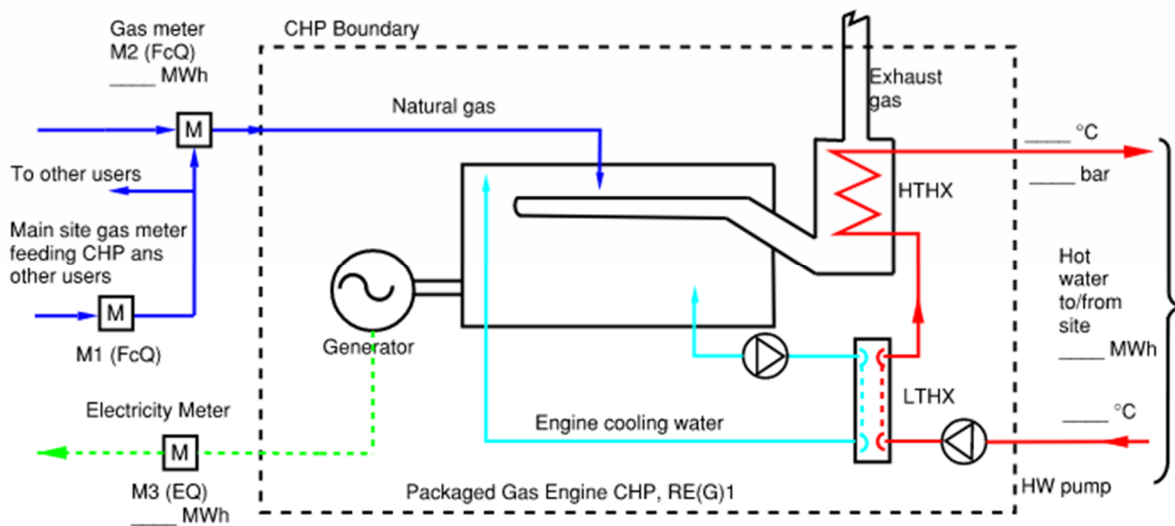

## Reciprocating Engine CHP providing Hot Water Heat Output with Heat Rejection Facility

