

O/0055/26

REGISTERED DESIGNS ACT 1949 (AS AMENDED)

**IN THE MATTER OF REGISTERED DESIGN NO. 6369724
IN THE NAME OF FREAK ATHLETE ESSENTIALS LLC
IN RESPECT OF THE FOLLOWING DESIGN:**

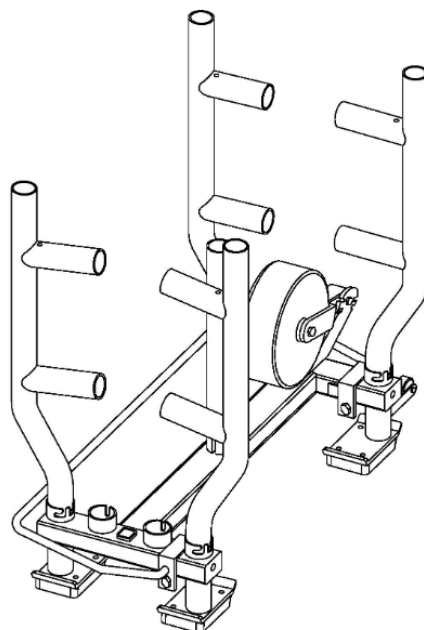

AND

**AN APPLICATION FOR INVALIDATION (NO 246/24)
BY SLANTBOARD LIMITED**

Background

1. On 23 January 2026, a decision in the above proceedings was published under reference number BL O/0043/26. The outcome of the decision was that the registered design was invalid.

Supplementary Decision

2. It was brought to my attention on 26 January 2026 (via an email to the Tribunal from the registered proprietor's representative) that paragraph 14 of this decision contained an error, in that the name of the applicant appears to have been accidentally pasted into the text. This is how the paragraph read:

“14. On 18 December 2024 the tribunal consolidated this case with 244/24. While writing this decision and having considered both cases, I find them to be unsuitable to be written as one decision, as they relate to two very different designs. I will write these decisions separately and SlantBoard Limited will publish them at the same time.”

3. The version of the paragraph that should have been published is shown below:

“14. On 18 December 2024 the tribunal consolidated this case with 244/24. While writing this decision and having considered both cases, I find them to be unsuitable to be written as one decision, as they relate to two very different designs. I will write these decisions separately and will publish them at the same time.”

4. This clerical error is plainly an irregularity in procedure and capable of being corrected under Rule 38 of the Registered Designs Rules 2006. Consequently, I give the parties notice that paragraph 14 of my decision will be amended as shown above and applies as though it had appeared in the original version of my decision.

Appeal Period

5. The issuing of this supplementary decision does not impact upon the appeal period set in my original decision.

Dated this 27th day of January 2026

AI Skilton

For the Registrar,

The Comptroller-General