

# Mergers: Guidance on the CMA's jurisdiction and procedure

**CMA2**

2 January 2025



© Crown copyright 2025

You may reuse this information (not including logos) free of charge in any format or medium, under the terms of the Open Government Licence.

To view this licence, visit [www.nationalarchives.gov.uk/doc/open-government-licence/](http://www.nationalarchives.gov.uk/doc/open-government-licence/) or write to the Information Policy Team, The National Archives, Kew, London TW9 4DU, or email: [psi@nationalarchives.gov.uk](mailto:psi@nationalarchives.gov.uk).

## Contents

	<i>Page</i>
1. Preface .....	3
2. Introduction .....	5
3. The legal framework .....	10
4. Jurisdiction and relevant merger situations .....	13
5. The phase 1 process: overview .....	44
6. Notification of mergers to the CMA .....	50
7. Fast track processes and conceding an SLC .....	60
8. Interactions with other proceedings .....	67
9. The phase 1 assessment process .....	69
10. The phase 2 process: overview .....	96
11. The phase 2 assessment process .....	104
12. The phase 2 remedy process .....	125
13. The abandonment process .....	132
14. Public interest mergers .....	134
15. Interactions with other regulatory processes .....	142
16. Multi-jurisdictional mergers .....	144
17. Communication and publication of decisions, undertakings and orders .....	147
18. Fees .....	159

### *Appendices*

- A: Guidance on the calculation of turnover for the purposes of Part 3 of the Act
- B: Guidance and commentary in relation to the CMA's assessment of mergers
- C: Ancillary restraints
- D: Contact details

# 1. Preface

- 1.1 The Competition and Markets Authority's (CMA's) merger control function is part of its duty to promote competition for the benefit of consumers.<sup>1</sup> Its merger control procedures are designed to fulfil this duty in an efficient manner, while ensuring that the merger parties' rights to due process are fully respected. The CMA is also required to balance the rights of the merger parties with those of third parties.
- 1.2 This guidance forms part of the advice and information published by the CMA under [section 106](#) of the Enterprise Act 2002 (the Act). It is designed to provide general information and advice to companies and their advisers on the procedures used by the CMA in operating the merger control regime set out in the Act. It also includes guidance on when the CMA will have jurisdiction to review mergers under the Act, and it explains the respective roles of the CMA, the Secretary of State, and relevant sectoral regulators in UK merger control.<sup>2</sup>
- 1.3 This guidance reflects experience gained since the Act entered into force in 2003 and reflects changes brought about by the Digital Markets Competition and Consumers Act 2024 (the DMCC Act). It replaces the version of CMA2 published in April 2024. This guidance document will be kept under review.
- 1.4 This guidance should be read alongside other CMA guidance including in particular: [Merger Assessment Guidelines \(CMA129\)](#); [Merger Remedies \(CMA87\)](#); [Guidance on the CMA's mergers intelligence function \(CMA56revised\)](#); [Interim measures in merger investigations \(CMA108\)](#); [Mergers: Exceptions to the duty to refer \(CMA64\)](#); [Guidance on requests for internal documents in merger investigations \(CMA100\)](#); [Administrative Penalties: Statement of policy on the CMA's approach \(CMA4\)](#); and [Transparency and disclosure: Statement of the CMA's policy and approach \(CMA6\)](#). A full list of relevant guidance is provided in Appendix B.
- 1.5 Where there is any difference in emphasis or detail between this guidance and other guidance produced or adopted by the CMA, the most recently published document takes precedence.

---

<sup>1</sup> [Section 25\(3\)](#) of the Enterprise and Regulatory Reform Act 2013 (the ERRA13).

<sup>2</sup> At the date of publication of this guidance the relevant sectoral regulators for the purposes of this guidance are: the Office of Communications (Ofcom); the Gas and Electricity Markets Authority (Ofgem); the Oil and Gas Authority (OGA); the Water Services Regulation Authority (Ofwat); the Northern Ireland Authority for Utility Regulation (URRegNI); the Office of Rail and Road (ORR); the Civil Aviation Authority (CAA); NHS England; the Financial Conduct Authority (FCA); and the Payment Systems Regulator (PSR).

- 1.6 While the CMA will have regard to this guidance in handling mergers under the Act, it will apply this guidance flexibly and may depart from the approach described in the guidance where there is an appropriate and reasonable justification for doing so.

## 2. Introduction

### Scope of the guidance

- 2.1 This guidance describes the procedures used by the CMA in operating the merger control regime set out in the Act. In particular, this guidance discusses the criteria that the CMA applies to determine whether it has jurisdiction under the Act (chapter 4) and the policies and procedures that the CMA will use in discharging its functions under the Act (chapter 5 onwards).
- 2.2 This guidance does not address the substantive ‘substantial lessening of competition’ (SLC) test against which the CMA assesses whether a merger raises competition concerns. Detailed information on the application of the substantive test for mergers is provided in [Merger Assessment Guidelines \(CMA129\)](#). This guidance also does not explain the CMA’s approach and requirements in the selection, design and implementation of remedies in merger investigations, which is covered in [Merger Remedies \(CMA87\)](#).
- 2.3 Other aspects of the CMA’s practice in merger control cases (for example in relation to the use of interim measures,<sup>3</sup> the approach taken to considering whether non-notified cases should be called in for investigation<sup>4</sup> and the approach taken to gathering internal documents<sup>5</sup>) are referred to in this guidance but explained more fully in separate guidance documents.

### Who does what?

- 2.4 The Act assigns distinct roles in relation to merger control to the CMA, the Secretary of State, and certain sectoral regulators. The inter-relationship between these roles is summarised in the following paragraphs.

### **The CMA**

- 2.5 The Enterprise and Regulatory Reform Act 2013 (ERRA13)<sup>6</sup> established the CMA as the UK’s economy-wide competition authority responsible for ensuring that competition and markets work well for consumers. The CMA’s duty is to seek to promote competition, both within and outside the UK, for the benefit of consumers.

---

<sup>3</sup> [Interim measures in merger investigations \(CMA108\)](#).

<sup>4</sup> [Guidance on the CMA’s mergers intelligence function \(CMA56revised\)](#).

<sup>5</sup> [Guidance on requests for internal documents in merger investigations \(CMA100\)](#).

<sup>6</sup> See: [Enterprise and Regulatory Reform Act 2013 \(legislation.gov.uk\)](#).

- 2.6 Under the Act, the CMA has a function to obtain and review information relating to merger situations, and a duty to refer for an in-depth 'phase 2' investigation any relevant merger situation where it believes that it is or may be the case that the merger has resulted or may be expected to result in an SLC in a UK market.
- 2.7 Following a reference for a phase 2 investigation, the CMA conducts a more detailed analysis to determine whether: (i) there is a relevant merger situation falling within the UK merger control regime, (ii) that relevant merger situation has resulted, or may be expected to result, in an SLC, and (iii) it should take action to remedy any SLC identified.
- 2.8 At phase 2, those decisions are taken by an Inquiry Group, selected for each case from the independent experts appointed by the Secretary of State to the CMA's panel.
- 2.9 The CMA's role in relation to public interest merger cases is set out in chapter 14.
- 2.10 The CMA's role relating to the mandatory reporting requirement for digital mergers is set out in Part I (Chapter 5) of the DMCC Act and the *Guidance on the merger reporting requirements for SMS firms* (CMA195).

### ***The Secretary of State***

- 2.11 The Secretary of State has a role in certain public interest cases and cases raising national security concerns, as described more fully below in chapters 14 and 15. The decision on the competitive effects of a merger is, however, solely for the CMA under the Act. Outside the public interest interventions described in chapter 14, the UK merger control process is independent of government and the UK Government does not play any role within, or otherwise exercise any influence over, a CMA merger control investigation.

### ***The sectoral regulators***

- 2.12 The CMA routinely consults the sectoral regulators about any mergers in which they are likely to have industry-specific knowledge. This is described further in chapter 9 below. In addition, Ofwat, Ofcom, Ofgem and NHS England have statutory roles in the assessment of, respectively, certain water mergers, media mergers, mergers of energy networks and mergers involving NHS trusts. See chapters 9 and 15 below.

## Overview of the CMA's merger investigation process

2.13 Figure 1 below provides a high-level summary of the principal stages in phase 1 and phase 2 merger investigations undertaken by the CMA, from initial contact with the CMA through to, in appropriate cases, the outcome of a full, two-phase investigation.<sup>7</sup> While this broad process applies in all CMA merger investigations, the approach adopted can (as explained further in this guidance) vary depending on the circumstances of the case.<sup>8</sup>

---

<sup>7</sup> Figure 1 provides a summary only: it does not show, for example, processes that are relevant only in certain limited cases (such as public interest cases, or local media mergers, where the Secretary of State, or Ofcom respectively have a role).

<sup>8</sup> One such variation is a 'fast-track' case, as described further in chapter 7.



Figure 1: CMA merger investigations – principal stages

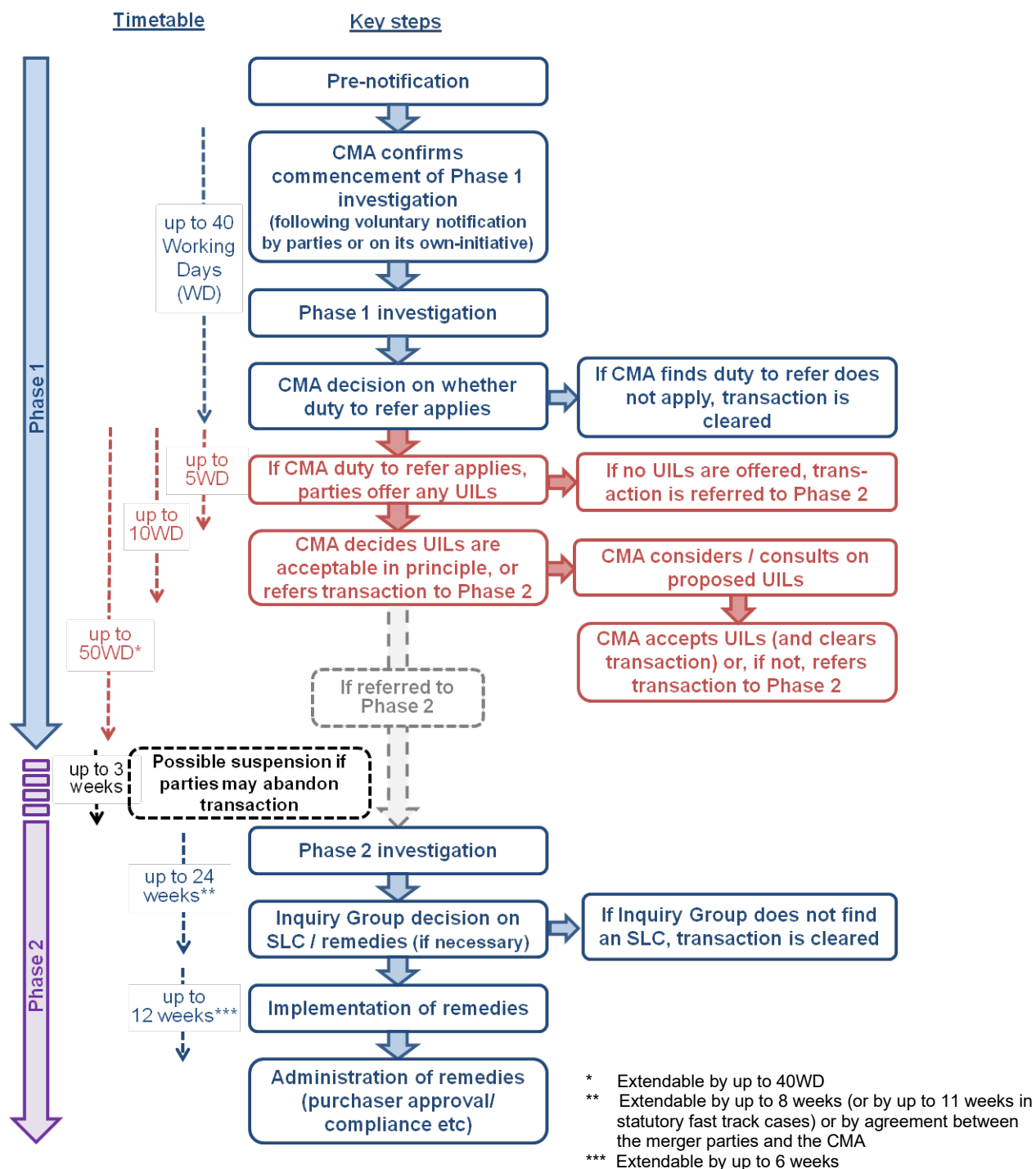

## The structure of this guidance

2.14 This guidance seeks to follow broadly the chronology of the UK merger process shown in Figure 1 above. To this end, it is structured as follows:

- (a) **Chapters 3 and 4** set out the legal framework for the UK merger control regime and provide guidance on the relevant merger situations which the CMA has jurisdiction to review;
- (b) **Chapters 5 to 9** provide guidance on the phase 1 process, from initial contact with the CMA, and covers the notification of mergers and ‘calling in’ of non-notified mergers;
- (c) **Chapters 10 to 13** provide guidance on the phase 2 process, explaining the further information-gathering and assessment that the CMA may undertake as part of this more in-depth examination of the merger and the role of CMA panel members in the investigation and decision-making process including the remedies process. These chapters also explain the process followed in cancelling an investigation;
- (d) **Chapters 14 to 18** provide more general information on the different process applicable to public interest mergers, the interaction of the UK merger control regime with other regulatory processes, considerations relating to international (multi-jurisdictional) mergers, communication and publication of CMA merger decisions, and the payment of merger fees to the CMA following its phase 1 investigation; and
- (e) finally, the **appendices** provide further information on the calculation of turnover, other published CMA guidance in relation to mergers, ancillary restraints, and relevant contact addresses.

## Further information

2.15 Further information can be obtained from the CMA’s mergers homepage at <https://www.gov.uk/topic/competition/mergers>, and in the guidance listed in Appendix B.

### 3. The legal framework

#### The statutory questions

- 3.1 The Act imposes a duty on the CMA to refer completed and anticipated mergers for an in-depth phase 2 investigation if it believes that it is or may be the case that:
- (a) a relevant merger situation has been created or arrangements are in progress or in contemplation which, if carried into effect, will result in the creation of a relevant merger situation; and
  - (b) the creation of that situation has resulted, or may be expected to result, in an SLC within any market or markets for goods or services in the UK.<sup>9,10</sup>
- 3.2 The CMA may, however, decide not to make a reference for a phase 2 investigation if it believes that:
- (a) the market concerned is not, or the markets concerned are not, of sufficient importance to justify the making of a reference;
  - (b) any relevant customer benefits (RCBs) in relation to the creation of the relevant merger situation outweigh the SLC concerned and any adverse effects of that SLC; or
  - (c) in the case of an anticipated merger, the arrangements concerned are not sufficiently far advanced, or are not sufficiently likely to proceed, to justify the making of a reference.<sup>11</sup>
- 3.3 Where the CMA finds that it is under a duty to refer a merger for a phase 2 investigation, it may, under [section 73](#) of the Act, accept undertakings in lieu of reference (UILs) to remedy, mitigate or prevent the SLC concerned or any adverse effect of it (for further information on the CMA's approach to merger remedies see [Merger Remedies \(CMA87\)](#)).
- 3.4 In certain limited circumstances, the CMA is not able to refer a merger. For example, in the case of a completed merger, the CMA is not able to refer a

---

<sup>9</sup> Crown dependencies (Jersey, Guernsey and the Isle of Man) are not part of the UK and may have separate merger control laws applicable in their respective jurisdictions (for example Jersey has a specific merger control regime: see the Jersey Competition Regulatory Authority at [Jersey Competition Regulatory Authority \(jcra.je\)](#)).

<sup>10</sup> Sections [22\(1\)](#) and [33\(1\)](#) of the Act.

<sup>11</sup> Sections [22\(1\)](#) and [33\(1\)](#) of the Act.

merger if the four-month period following the completion of the acquisition (as extended where applicable) has expired.<sup>12</sup>

- 3.5 Following a reference for a phase 2 investigation, the Inquiry Group must decide:
- (a) whether a relevant merger situation has been or will be created; and
  - (b) if so, whether the creation of that situation has resulted, or may be expected to result, in an SLC within any market or markets in the UK for goods or services (where both limbs are satisfied, this is referred to as an ‘anti-competitive outcome’).<sup>13</sup>
- 3.6 If the Inquiry Group finds that there is an anti-competitive outcome, it must decide:
- (a) whether action should be taken by it, or by others, to remedy, mitigate or prevent the SLC concerned or any adverse effect that has resulted from, or may be expected to result from, that SLC; and
  - (b) if action is to be taken, what action should be taken and what is to be remedied, mitigated or prevented.
- 3.7 While many mergers will not raise competition issues, the merger control process is designed to allow the CMA to identify those where such issues may arise, so that they may be properly investigated and, where necessary, resolved through appropriate remedies.
- 3.8 At phase 1, the CMA’s test for reference (its ‘duty to refer’) will be met if the CMA has a reasonable belief, objectively justified by relevant facts, that it is or may be the case (ie there is a realistic prospect) that the merger has resulted or may be expected to result in an SLC. At phase 2, the Inquiry Group is then required to decide whether the merger has resulted or may be expected to result (ie with a more than 50% chance) in an SLC. Further guidance on the application of these tests may be found in [Merger Assessment Guidelines \(CMA129\)](#).

---

<sup>12</sup> [Section 24\(1\)](#) of the Act.

<sup>13</sup> [Section 35\(2\)](#) of the Act.

## Public interest interventions

3.9 The Act permits intervention by the Secretary of State in cases where public interest issues arise.<sup>14</sup> In such cases, the CMA is responsible for the competition assessment, but the Secretary of State may take public interest factors into account in deciding whether to make a reference to phase 2, accept UILs, or impose remedies following a phase 2 investigation. The public interest considerations that the Secretary of State may take into account are those relating to:<sup>15</sup>

- (a) media plurality and other considerations relating to newspaper and certain other media mergers;
- (b) the stability of the UK financial system; and
- (c) the need to maintain in the UK the capability to combat, and to mitigate the effects of, public health emergencies.<sup>16</sup>

3.10 The Secretary of State is able to intervene in special public interest cases where the standard jurisdictional thresholds relating to share of supply and turnover are not satisfied. The Secretary of State can only intervene in special public interest cases where the merger involves certain newspaper or broadcasting companies.<sup>17</sup> These are known as special merger situations and are considered under the special public interest regime of the Act. There is no competition assessment in such cases.

---

<sup>14</sup> [Section 42](#) of the Act.

<sup>15</sup> The Secretary of State has the power to add further public interest considerations by statutory instrument. See sections [58\(3\)](#) and [58\(4\)](#) of the Act. The public interest considerations that the Secretary of State could take into account previously included national security. This was removed as a public interest consideration for the purposes of the Act by the NSI Act, the effect of which is described further in chapters 14 and 15 below.

<sup>16</sup> [Section 58](#) of the Act.

<sup>17</sup> [Section 59](#) of the Act.

## 4. Jurisdiction and relevant merger situations

### Introduction

- 4.1 The question of whether there is a ‘relevant merger situation’ under the Act or arrangements are in progress or contemplation that will give rise to such a relevant merger situation is relevant at both phase 1 and phase 2.<sup>18</sup>
- 4.2 The Act’s definition of a ‘relevant merger situation’ covers several different kinds of transaction and arrangement. A company that buys or intends to buy a majority shareholding or a significant minority shareholding in another company is the most obvious example, but other arrangements such as the transfer or pooling of assets or employees, the creation of a joint venture, or outsourcing arrangements may, in certain circumstances, also give rise to relevant merger situations. The Act’s provisions apply both to mergers that have already taken place (subject to time limits) and to those that are proposed or in contemplation.
- 4.3 A merger must meet all three of the following criteria to constitute a relevant merger situation for the purposes of the Act:<sup>19,20</sup>
- (a) first, either:

---

<sup>18</sup> See paragraphs 2.6 and 2.7 above in relation to the standard of proof required for these decisions at phase 1 and phase 2.

<sup>19</sup> In some circumstances, the CMA may need to consider a transaction which gives rise to more than one change of control (for example, where a seller acquires shares in the acquirer in consideration for selling the target) or more than one commercial agreement. Provided that these changes of control or commercial agreements are interconnected and take place in the context of the same overall commercial transaction, the CMA will generally treat these changes of control or commercial agreements as part of a single relevant merger situation. See, for example: Anticipated acquisition by Farfetch Limited of a shareholding in, and certain rights over, YOOX Net-a-Porter Group S.p.A. from Compagnie Financière Richemont S.A. in consideration for the acquisition by Compagnie Financière Richemont S.A. of a minority shareholding in Farfetch Limited (29 March 2023); Merger between Capital & Counties Properties PLC and Shaftesbury PLC (22 February 2023); CMA Decision: Anticipated joint venture between ForFarmers N.V. (via ForFarmers UK Holdings Limited) and Boparan Private Office Limited (via Amber REI Holdings Limited) concerning ForFarmers UK Limited and 2 Agriculture Limited (21 December 2022); and Anticipated acquisition by Motor Fuel Limited of 90 petrol stations from Shell Service Station Properties Limited, Shell U.K. Limited and GOGB Limited (26 August 2015). In certain limited circumstances, however, it may be appropriate to treat a single commercial transaction as giving rise to more than one relevant merger situation. See, for example: CMA Decision: Completed acquisition by Circle Health Holdings of GHG Healthcare Holdings (8 April 2020); CMA Decision: Anticipated joint venture between Dawn Meats and Dunbia (29 September 2017); and the CC’s Thomas Cook Group plc/Co-operative Group Limited/Midlands Co-operative Society Limited inquiry (2011).

<sup>20</sup> [Section 23](#) of the Act.

- (i) two or more enterprises (broadly speaking, business activities of any kind)<sup>21</sup> must cease to be distinct; or
  - (ii) there must be arrangements in progress or in contemplation which, if carried into effect, will lead to enterprises ceasing to be distinct;
- (b) and second, any one of:
  - (i) the UK turnover associated with the enterprise which is being acquired exceeds £100 million (this is referred to as 'the turnover test');<sup>22</sup> or
  - (ii) at least one of the enterprises which ceases to be distinct has a UK turnover exceeding £10 million, and the enterprises that cease to be distinct supply or acquire goods or services of any description and, after the merger, together supply or acquire at least 25% of all those particular goods or services of that kind supplied in the UK or in a substantial part of it. The merger must also result in an increment to the share of supply or acquisition (this is referred to as 'the share of supply test');<sup>23,24</sup> or
  - (iii) the person(s) that carry on an enterprise concerned supply or acquire at least 33% of goods or services of any description in the UK (or a substantial part of the UK); the same enterprise concerned has a UK turnover exceeding £350 million; and any other enterprise concerned has a UK nexus (this is referred to as the 'hybrid test').<sup>25</sup>
- (c) and third, either:
  - (i) the merger must not yet have taken place; or
  - (ii) the date of the merger must be no more than four months before the day the reference is made, unless the merger took place without having been made public and without the CMA being informed of it (in which case the four-month period starts from the earlier of the time the

---

<sup>21</sup> See paragraphs 4.6 to 4.15 below.

<sup>22</sup> See paragraphs 4.52 to 4.57 below.

<sup>23</sup> See paragraphs 4.58 to 4.71 below.

<sup>24</sup> Special jurisdictional thresholds previously applied where the enterprise being taken over (or part of it) constituted a 'relevant enterprise', ie where it was active in certain specified areas, including artificial intelligence and the development or production of items for military or military and civilian use. The provisions of the Act relating to 'relevant enterprises' were removed by [section 58](#) of the NSI Act.

<sup>25</sup> See paragraphs 4.72 to 4.91 below.

merger was made public or the time the CMA was told about it).<sup>26</sup> This four-month deadline may be extended in certain circumstances.<sup>27</sup>

- 4.4 In the context of mergers that have not yet completed, at phase 1 the CMA will generally consider that ‘arrangements are in progress or in contemplation’ for the purposes of section 33 of the Act if a public announcement has been made by the merger parties concerned.<sup>28</sup>

## Enterprises ceasing to be distinct

- 4.5 Two enterprises will ‘cease to be distinct’ if they are brought under common ownership or control.<sup>29</sup>

### *Enterprises*

- 4.6 The term ‘enterprise’ is defined in [section 129](#) of the Act as the activities, or part of the activities, of a business. This does not mean that the enterprise in question need be a separate legal entity: it simply means that the activities in question could be carried on for gain or reward. However, there is no requirement that the transferred activities have generated,<sup>30</sup> or are expected to generate, a profit or dividend for shareholders: indeed, the transferred activities may be loss-making or conducted on a not-for-profit basis.<sup>31</sup>
- 4.7 In making a judgement as to whether or not the activities of a business, or part of a business, constitute an enterprise under the Act, the CMA will have regard to the substance of the arrangement under consideration, rather than merely its legal form.<sup>32</sup>

---

<sup>26</sup> In this context, the date of the merger refers to the date when the enterprises cease to be distinct (see [section 24\(1\)](#) of the Act).

<sup>27</sup> See for example sections [25](#), [42](#) and [122](#) of the Act.

<sup>28</sup> In the case of a public bid, this will generally mean announcement of a possible offer or of a firm intention to make an offer.

<sup>29</sup> [Section 26](#) of the Act. In the case of a ‘start-up’ joint venture, the question under the Act will be whether the activities transferred to the joint venture by one or more parents (or acquired from a third party) are sufficient to constitute an enterprise.

<sup>30</sup> See CMA Decision: Anticipated acquisition by Roche Holdings of Spark Therapeutics (16 December 2019).

<sup>31</sup> See CMA Decision: Anticipated acquisition by Bupa Insurance Limited of Civil Service Healthcare Society Limited (24 September 2020). NHS Foundation Trusts may also constitute enterprises for this purpose – see chapter 9 below. See also CMA Decision: Anticipated merger between The Royal Bournemouth and Christchurch Hospitals NHS Foundation Trust and Poole Hospital NHS Foundation Trust (27 April 2020).

<sup>32</sup> For example, the fact that the merger was effected via two legal agreements rather than a single agreement did not mean that the target did not constitute one enterprise in CMA Decision: Completed acquisition by Rentokil Initial plc of MPCL Ltd (formerly Mitie Pest Control Ltd) (12 April 2019). And the fact that there was no direct sale agreement between the existing cinema operator and the new cinema operator did not preclude enterprises



- 4.8 An 'enterprise' may comprise any number of components, most commonly including some combination of the assets and records needed to carry on certain activities of the business, employees working in the business, and existing contracts and/or goodwill. However, the Act does not require that a business (or part thereof) be of any minimum scale, or include any particular combination of components, in order to constitute an enterprise.<sup>33</sup>
- 4.9 In some cases, the transfer of assets or employees alone may be sufficient to constitute an enterprise: for example, where the facilities or site transferred, or a group of employees and their know-how, enables a particular business activity to be continued. A collection of 'bare assets' is unlikely to amount to an enterprise for the purposes of the Act.<sup>34</sup> An enterprise would generally require something more than bare assets, related to the fact that the assets being transferred were previously employed in combination in the activities of the business being acquired.<sup>35</sup> There is, however, no requirement for the business being transferred to include physical assets, or any particular category of asset, in order to constitute an enterprise under the Act.
- 4.10 The CMA's assessment of whether what is being acquired amounts to an enterprise will depend on the specific facts and circumstances of each case and the industry in question. No one single factor will necessarily be determinative. Rather, the CMA will make an assessment based on the totality of all relevant considerations.
- 4.11 Where a transaction results in the acquisition of parts of a business, in determining whether the activities or components of the business being acquired constitute an enterprise, the CMA will have particular regard to whether the transaction includes:
- (a) The transfer of tangible or intangible assets. However, intangible assets such as intellectual property rights (including know-how) are unlikely, on their own, to constitute an enterprise unless it is possible to identify

---

ceasing to be distinct for the purposes of the Act in the OFT Decision: Anticipated acquisition by Cineworld Group plc, through its subsidiary Cine-UK Limited, of the Cinema Business operating at the Hollywood Green Leisure Park, Wood Green (17 March 2008).

<sup>33</sup> For instance, there is no requirement for the inclusion of physical assets. See CMA Decisions: Completed agreement between Aer Lingus Limited and CityJet designated Activity Company (21 December 2018); Anticipated acquisition by Arla Foods Limited of Yeo Valley Dairies Limited, including a licence to supply certain dairy products under the Yeo Valley brand (11 July 2018); and Completed acquisition by Medtronic plc of certain assets of Animas Corporation (30 May 2018).

<sup>34</sup> *Société Cooperative De Production Seafrance SA (Respondent) v The Competition and Markets Authority and another (Appellants)* [2015] UKSC 75 ('Eurotunnel') at paragraphs 39 and 40, endorsing the CAT's view in *Groupe Eurotunnel SA v Competition Commission* [2013] CAT 30 at paragraph 105.

<sup>35</sup> *Société Cooperative De Production Seafrance SA (Respondent) v The Competition and Markets Authority and another (Appellants)* [2015] UKSC 75 ('Eurotunnel') at paragraphs 39 and 40.

recently-generated turnover directly related to the transferred intangible assets (or expected revenues directly related to the assets being transferred without material further development).<sup>36</sup>

- (b) The transfer of business data (including customer databases, lists or other customer relationships).<sup>37</sup>
- (c) The transfer of employees, including under the TUPE regulations.<sup>38</sup>
- (d) Consideration for the goodwill obtained by the purchaser. The presence of a price premium being paid over the value of any assets being transferred would be indicative of goodwill being transferred.<sup>39</sup>
- (e) The transfer of trademarks, trade names, or domain names.

4.12 The CMA will also consider, as an important factor, whether the combination of components results in a degree of economic continuity in the activities of the business being transferred.

4.13 Outsourcing arrangements involving ongoing supply arrangements will not generally result in enterprises ceasing to be distinct, but may do so where, for example, they involve the permanent (or long-term) transfer of assets, rights and/or employees to the outsourcing service supplier and where those may be used to supply services other than to the original owner/employer. The CMA will assess whether, overall, the assets, rights and employees transferred to the outsourcing service supplier are such as to constitute an enterprise under the principles set out above.<sup>40</sup>

---

<sup>36</sup> See, for example: the CC's inquiry into the Anticipated joint venture between The British Broadcasting Corporation, ITV Broadcasting Limited, Channel 4 Television Corporation, Channel 5 Broadcasting Limited, British Telecommunications plc, Talk Talk Telecoms Limited and Arqiva Limited – Project Canvas inquiry (2010); and OFT Decision: Completed supplier agreement between Guestlogix Inc and Panasonic Avionics in respect of a commercial arrangement to provide services in the development of onboard point of sale payment facility integrated into in-flight entertainment systems (21 December 2012).

<sup>37</sup> See CMA Decisions: Completed acquisition by Medtronic plc of certain assets of Animas Corporation (30 May 2018); and Completed agreement between Aer Lingus Limited and CityJet designated Activity Company (21 December 2018).

<sup>38</sup> The Transfer of Undertakings (Protection of Employment) Regulations 2006. See, for example, CMA Decisions: Completed agreement between Aer Lingus Limited and CityJet designated Activity Company (21 December 2018); Anticipated acquisition by Arla Foods Limited of Yeo Valley Dairies Limited, including a licence to supply certain dairy products under the Yeo Valley brand (11 July 2018); and Completed acquisition by Medtronic plc of certain assets of Animas Corporation (30 May 2018).

<sup>39</sup> See CMA Decision: Completed acquisition by Medtronic plc of certain assets of Animas Corporation (30 May 2018).

<sup>40</sup> See CMA Decision: Anticipated acquisition by DHL Supply Chain Limited of the enterprise constituted by the secondary distribution assets of Carlsberg Supply Company UK Limited (13 January 2017); OFT Decision:

- 4.14 The fact that a target business may no longer be, or has not yet started, actively trading does not in itself prevent it, or a combination of its assets, from being an enterprise for the purposes of the Act.<sup>41</sup> The CMA will consider whether what is being acquired amounts to more than ‘bare assets’, owing to the fact that the assets were previously employed in combination in the activities of a business (or would be employed in combination to commence active trading). In such cases, while the relevant criteria may vary according to the particular circumstances of a case, the CMA will consider, for example:
- (a) the period of time elapsed since the business was last trading (if relevant);
  - (b) the extent and cost of the actions that would be required in order for the business to start trading;<sup>42</sup>
  - (c) the extent to which customers, investors and competitors would regard the assets transferred as, in substance, amounting to a business; and
  - (d) whether, despite the fact that the business is not trading, goodwill or other benefits may be acquired beyond the assets being transferred.<sup>43</sup>
- 4.15 None of these factors, individually, is necessarily conclusive. The CMA will assess all relevant circumstances, with a view to determining whether the target business constitutes an enterprise under the Act.

---

Anticipated contract award to Nuclear Management Partners Limited as the Parent Body Organisation for Sellafield Limited (22 October 2008); and OFT Decision: Completed acquisition by AEG Facilities (UK) Limited of the contract to manage Wembley Arena (22 March 2013). Similar principles apply in relation to the award of contracts or concessions. See CMA Decision: Acquisition by Keolis Amey Docklands Limited of the Docklands Light Railway Franchise (14 November 2014); and OFT Decision: Anticipated acquisition by Tramlink Nottingham Consortium of NET Phase Two concession (12 September 2011).

<sup>41</sup> Considered in *Société Coopérative de Production SeaFrance SA v Competition and Markets Authority* [2015] UKSC 75 at paragraph 37 ff. See also *Groupe Eurotunnel SA v Competition Commission* [2013] CAT 30, and *Groupe Eurotunnel SA v Competition and Markets Authority* [2015] CAT 1. Although these judgments considered the acquisition of assets from an entity that was no longer actively trading, the CMA considers that the principles are of broader application, including to cases in which the target business has not yet started actively trading.

<sup>42</sup> See for example, OFT Decision: Completed acquisition by European Metal Recycling of five sites and certain assets of SITA Metal Recycling (7 March 2014). It is not essential for the purposes of the jurisdictional test for the buyer to use the business assets in the same manner as they were used before transfer (including, if relevant, before the target enterprise ceased trading). See also OFT Decisions: Completed acquisition by a consortium of Shell UK Limited, Greenergy International Limited and Vopak Holdings UK Limited of certain assets of former Petroplus Refining and Marketing Limited (24 May 2013); and Completed acquisition by Servisair UK Limited of the regional ground handling business of Aviance UK Limited (27 May 2010).

<sup>43</sup> See OFT Decisions: Completed acquisition by European Metal Recycling of five sites and certain assets of SITA Metal Recycling (7 March 2014); The assignment of a lease to Tesco plc for the site of a former FreshXpress store at St Helens (21 April 2009); Anticipated acquisition by Cineworld Group plc, through its subsidiary Cine-UK Limited, of the cinema business operating at the Hollywood Green Leisure Park, Wood Green (17 March 2008); and Completed acquisition by Home Retail Group plc of 27 leasehold properties from Focus (DIY) Limited (15 April 2008).

## Control

4.16 'Ceasing to be distinct' is defined in [section 26](#) of the Act as two enterprises being brought under common ownership or common control. 'Control' is not limited to the acquisition of outright voting control but may include situations falling short of outright voting control. [Section 26](#) of the Act distinguishes three levels of interest (in ascending order):

(a) material influence;

(b) de facto control; and

(c) a controlling interest (also known as 'de jure', or 'legal' control).

### **Material influence**

4.17 The ability to exercise material influence is the lowest level of control that may give rise to a relevant merger situation. When making its assessment, the CMA focuses on the acquirer's ability materially to influence policy relevant to the behaviour of the target entity in the marketplace. The policy of the target in this context means the management of its business, and thus includes the strategic direction of a company and its ability to define and achieve its commercial objectives.<sup>44</sup>

4.18 The assessment of material influence requires a case-by-case analysis of the overall relationship between the acquirer and the target. In making its assessment, the CMA will have regard to all the circumstances of the case.

4.19 A finding of material influence may be based on the acquirer's ability to influence the target's policy through exercising votes at shareholders' meetings, together with, in some cases, any additional supporting factors (see paragraph 4.24 below). However, material influence may also arise as a result of the ability to influence the board of the target, and/or through other arrangements: that is, without the acquirer necessarily being able to block votes at shareholders' meetings.

4.20 Each of these potential sources of influence (shareholding, board representation, and other sources) is described further below. The variety of commercial arrangements entered into by firms makes it difficult to state categorically what will (or will not) constitute material influence. The following

---

<sup>44</sup> The CMA does not consider that material influence is likely to arise in situations where a shareholder has no more than the rights normally accorded to minority shareholders, such as rights in the context of a liquidation.

matters may be of particular relevance, although this list is by no means exhaustive.

### *Shareholdings*

- 4.21 The size of the acquirer's minority shareholding in the target company will typically have a direct bearing on the extent of the acquirer's voting power at a shareholders' meeting, and thus on the acquirer's influence on the corporate and strategic decisions of the target company. For example, a shareholding conferring on the holder more than 25% of the voting rights in a UK company generally enables the holder to block special resolutions.
- 4.22 Given the nature of the decisions that typically will require a special resolution – and which the holder could therefore block – a share of voting rights of over 25% is likely to be seen as conferring the ability materially to influence policy – even when all the remaining shares are held by only one person.
- 4.23 Shareholdings of below 25% will typically be less likely to confer material influence. However, the CMA may examine any shareholding to determine whether the holder might be able materially to influence the company's policy. Even shareholdings of less than 15% might attract scrutiny where other factors indicating the ability to exercise material influence over policy are present.<sup>45,46</sup>
- 4.24 In considering whether material influence may be present in a particular case, the CMA will consider not only whether the acquiring party has the right to block special resolutions but also whether, given other factors, it is able to do so as a practical matter.<sup>47</sup> This gives effect to the general principle that the purpose of UK merger control is to enable the CMA to consider the commercial realities and results of transactions and that the focus should be on substance and not legal form. Other factors relevant to whether special resolutions might be blocked in practice may include:

---

<sup>45</sup> See, for example, the factors discussed in paragraphs 4.31 and 4.32 below. In its past decisional practice, the CMA has only rarely found shareholdings of less than 15% to confer material influence on the acquirer.

<sup>46</sup> This does not mean that all cases in which parties obtain material influence through minority shareholdings need to be notified to the CMA, or will be investigated by the CMA on its own initiative. In deciding whether to investigate any such merger situation on its own initiative, the CMA will have regard to whether, on the information available to it, there is a reasonable chance that the test for a reference under the Act will be met.

<sup>47</sup> See CMA Decision: Anticipated acquisition by RWE AG of a 16.67% minority stake in E.On SE (5 April 2019); CMA Decision: Anticipated acquisition by Prosafe SE of Floatel International Limited (5 September 2019); OFT Report: Acquisition by British Sky Broadcasting Group plc of a 17.9% in ITV plc; Report to the Secretary of State for Trade and Industry (14 December 2007) and *British Sky Broadcasting Group plc v the CC and the Secretary of State* [2008] CAT 25; and OFT Decision: Anticipated acquisition by Centrica plc of a 20% stake in Lake Acquisitions Limited (a wholly owned subsidiary of EDF SA) (7 August 2009).

- (a) the distribution and holders of the remaining shares, for example whether the acquiring entity's shareholding makes it the largest shareholder; and
- (b) patterns of attendance and voting at recent shareholders' meetings based on recent shareholder returns,<sup>48</sup> and, in particular, whether voter attendance is such that a shareholder holding 25% of the voting rights or less would be able in practice to block special resolutions. In making this determination, the CMA may have regard to the votes of other shareholders that it considers may be expected to be voted with the acquirer against a special resolution.

4.25 In addition, an acquirer's shareholding, whilst insufficient in itself to enable the acquirer to defeat a special resolution (even as a practical matter), may still in some cases afford the acquirer special voting or veto rights over relevant policy or strategic matters sufficient to confer material influence.

4.26 The CMA may also have regard to the status and expertise of the acquirer, and its corresponding influence with other shareholders, and may consider whether, given the identity and corporate policy of the target company, the acquirer may be able materially to influence policy formulation through, for example, meetings with other shareholders.<sup>49</sup>

4.27 Where a company's appetite for pursuing certain strategies would be reduced because of a perception that these strategies would be likely to cause conflict with the acquirer, this may be an additional relevant factor in determining material influence.

### *Board representation*

4.28 In addition to the ability materially to influence policy through the voting of shares, the CMA's determination may also, or alternatively, turn on whether the acquirer is able materially to influence the policy of the target entity

---

<sup>48</sup> Given that any prediction of attendance and voting at shareholders' meetings is complex, involving a wide range of factors, the CMA considers that patterns of participation at recent shareholders' meetings of a particular company (for example over the last three years) are likely to be the best available indication of future participation.

<sup>49</sup> See, for example: CMA Final Report: Anticipated acquisition by Amazon of a minority shareholding and certain rights in Deliveroo (4 August 2020); CMA Decision: Anticipated acquisition by RWE AG of a 16.67% minority stake in E.On SE (5 April 2019); and the CC's British Sky Broadcasting Group/ITV plc inquiry (2007).

through board representation.<sup>50</sup> Indeed, board representation alone may confer material influence.<sup>51</sup>

- 4.29 Whether as a free-standing basis for material influence or as a supporting factor in the context of a shareholding, the CMA will review a range of factors in relation to such board representation, including, for example, the corporate/industry expertise,<sup>52</sup> other relevant experience or incentives of the various members of the board.<sup>53</sup>
- 4.30 Where a party acquires the right or ability to obtain board representation, the CMA considers it appropriate to take this right or ability into account in its jurisdictional assessment (and potentially also in its substantive assessment), even where it has not yet been exercised and/or there is no certainty about when it will be exercised in future.

#### *Other sources of material influence*

- 4.31 The CMA may also consider whether any other factors, such as agreements with the target company, might enable the acquirer materially to influence policy. Whilst there are no fixed types of agreement that will (or will not) be relevant to this assessment, such arrangements might include the provision of consultancy services to the target and other relevant customer/supplier relationships.
- 4.32 Financial arrangements may in certain circumstances confer material influence where the conditions are such that one party becomes so dependent on the other that the latter gains material influence over the company's commercial policy (for example, where a lender could threaten to withdraw loan facilities if a particular policy is not pursued, or where the loan conditions confer on the lender an ability to exercise rights over and above

---

<sup>50</sup> See CMA Final Report: Anticipated acquisition by Amazon of a minority shareholding and certain rights in Deliveroo (4 August 2020). See OFT Decisions: Completed acquisition by JCDecaux UK Limited of rights in Concourse Initiatives Limited and Media Initiatives Limited (19 March 2012); and Anticipated acquisition by Centrica plc of a 20% stake in Lake Acquisitions Limited (a wholly owned subsidiary of EDF SA) (7 August 2009).

<sup>51</sup> This does not mean that all cases in which parties obtain material influence through board representation need to be notified to the CMA. See footnote 46 for analogous considerations in the context of minority shareholdings.

<sup>52</sup> See CMA Decision: Anticipated acquisition by RWE AG of a 16.67% minority stake in E.On SE (8 April 2019). See the CC's report: Acquisition by British Sky Broadcasting Group of 17.9% of the shares in ITV (14 December 2007).

<sup>53</sup> See CMA Final Report: Anticipated acquisition by Amazon of a minority shareholding and certain rights in Deliveroo (4 August 2020). See OFT Decision: Completed acquisition by First Milk Limited of a 15% stake in Robert Wiseman Dairies plc (7 April 2005).

those necessary to protect its investment, say, by options to take control of the company or veto rights over certain strategic decisions).<sup>54</sup>

### ***De facto control***

- 4.33 Merger arrangements may give rise to a position of ‘de facto’ control when an entity controls a company’s policy, notwithstanding that it holds less than the majority of voting rights in the target company (that is, it does not have a controlling interest). De facto control requires the ability to unilaterally determine (as opposed to just materially influence) a company’s policy.<sup>55</sup> De facto control is likely to include situations where the acquirer has in practice control over more than half of the votes actually cast at shareholder meetings. However, other factors may be relevant and there is no ‘bright line’ between factors which might give rise to material influence and those giving rise to de facto control. For instance, de facto control might also involve situations where an investor’s industry expertise might lead to its advice being followed to a greater extent than its shareholding would seem to warrant.
- 4.34 The CMA has the ability under [section 26\(3\)](#) of the Act to decide whether or not to treat ‘de facto’ control as equivalent to ‘control’ for the purposes of establishing whether enterprises have been ‘brought under common ownership or common control’ within the meaning of the Act.

### ***A controlling interest***

- 4.35 A ‘controlling interest’ generally means a shareholding conferring more than 50% of the voting rights in a company. Only one shareholder can have a controlling interest, but it is not uncommon for a company to be subject to the control (in the wider senses described above) of two or more major shareholders at the same time – in a joint venture, for instance. Therefore, a significant minority shareholder may be seen as being able materially to influence a company’s policy even though someone else owns a controlling interest.

---

<sup>54</sup> See OFT Decision: Completed acquisition by First Milk Limited of a 15% stake in Robert Wiseman Dairies plc (7 April 2005).

<sup>55</sup> See CMA Final Report: Completed acquisition by Hunter Douglas N.V. of convertible loan notes and certain rights in 247 Home Furnishings Ltd. in 2013 and the completed acquisition by Hunter Douglas N.V. of a controlling interest in 247 Home Furnishings Ltd. in 2019 (14 September 2020).



## Acquiring control by stages

- 4.36 Under [section 26\(4\)](#) of the Act, should a shareholding (and/or a level of board representation) that confers the ability materially to influence a company's policy increase subsequently to a level that amounts to 'de facto' control or a controlling interest, that further acquisition may produce a new relevant merger situation (which is therefore potentially liable to reference for a phase 2 investigation and to the imposition of remedies at the end of the phase 2 process). The same applies to a move from 'de facto' control to a controlling interest.<sup>56,57</sup>
- 4.37 In principle, therefore, if Company A acquires Company B in stages, this could give rise to three separate relevant merger situations: first, as Company A acquires material influence; then to 'de facto' control; and, finally, to a controlling interest.<sup>58</sup> But further acquisitions of a company's shares by a person who already owns a controlling interest do not give rise to a new merger situation.
- 4.38 For the purposes of a merger reference, where a person acquires control of an enterprise (in any of the three senses described above) during a series of transactions or successive events within a single two-year period, sections [27\(5\)](#) and [29](#) of the Act allow them to be treated as having occurred or occurring simultaneously on the date of the last transaction.<sup>59</sup> The CMA has discretion in whether to apply these sections. In exercising this discretion, the CMA will have regard to the nature and extent of any competition issues

---

<sup>56</sup> See: CMA Final Report: Completed acquisition by Hunter Douglas N.V. of convertible loan notes and certain rights in 247 Home Furnishings Ltd. in 2013 and the completed acquisition by Hunter Douglas N.V. of a controlling interest in 247 Home Furnishings Ltd. in 2019 (14 September 2020); and OFT Decision: Anticipated acquisition by Cavendish Square Partners (General Partner) Limited of a controlling interest in each of Lakeside 1 Limited (Keepmoat) and Apollo Group Holdings Limited (Apollo) (24 November 2011).

<sup>57</sup> Such cases may qualify on the share of supply test (as well as the turnover test) given that [section 26\(4\)](#) of the Act allows for the acquirer to be 'treated' as bringing the target under its control (notwithstanding that it already had material influence or 'de facto' control over the target) such that there would therefore (under such 'treatment') be an increment in the share of supply.

<sup>58</sup> See OFT Decisions: Anticipated acquisition by The Coca-Cola Company of full control over Fresh Trading Limited (1 May 2013); Completed acquisition by Travis Perkins plc of a controlling interest in Toolstation Limited (29 March 2012); and Anticipated acquisition by Cavendish Square Partners (General Partner) Limited of a controlling interest in each of Lakeside 1 Limited (Keepmoat) and Apollo Group Holdings Limited (Apollo) (24 November 2011).

<sup>59</sup> See CMA Decisions: Completed acquisition by Veolia Environnement S.A. of a minority shareholding in Suez S.A. and the anticipated public takeover bid by Veolia Environnement S.A. for the remaining share capital of Suez S.A. (7 December 2021); and Completed acquisition by Co-operative Foodstores Limited of eight My Local grocery stores from ML Convenience Limited and MLCG Limited (19 October 2016); and OFT Decision: Completed acquisition by Dairy Crest Group plc of certain assets of Arla Foods UK plc (8 January 2007).

associated with the merger.<sup>60</sup> In giving effect to these provisions, the CMA may take into account transactions in contemplation (that is, where the last of the events has not yet occurred).<sup>61</sup>

- 4.39 A new merger situation would not arise directly from the fact that there has been a reduction in the level of a shareholder's control (for example from a controlling interest to 'de facto' control). However, it is possible in these circumstances that a merger situation could arise through a third party thereby acquiring material influence, 'de facto' control or a controlling interest.

## Temporary merger situations

- 4.40 The Act does not define the period of time that a merger situation should last in order for it to qualify as a relevant merger situation under the Act.<sup>62</sup> In theory, therefore, acquisitions of control intended purely as a temporary step in a wider overall transaction might constitute a relevant merger situation. In practice, such arrangements might include break-up bids, stake-building in the context of a public bid,<sup>63</sup> and 'warehousing' arrangements.<sup>64</sup>
- 4.41 Break-up bids occur where one or more entities purchase an enterprise pursuant to an agreement that the acquired enterprise will be divided up according to a pre-existing plan upon completion of the transaction. In some cases, the break-up bid is structured in anticipation of merger control concerns that would otherwise occur. The question therefore arises whether the CMA will consider the first step (that is, the initial acquisition of the target enterprise) as a separate relevant merger situation concerning the entire target enterprise, or whether it will examine the ultimate acquisitions in the second step (that is, after the target enterprise is split up).<sup>65</sup>

---

<sup>60</sup> See OFT Decision: Completed acquisitions by Tesco plc of the Co-operative Group's stores in Uxbridge Road, Slough (2 February 2004), in which the OFT declined to exercise its discretion.

<sup>61</sup> Article 3 of the Enterprise Act 2002 (Anticipated Mergers) Order 2003 SI2003/1595 (as amended).

<sup>62</sup> See CMA Decision: Completed agreement between Aer Lingus Limited and CityJet designated Activity Company (21 December 2018).

<sup>63</sup> In this situation, the CMA's decision if and when to investigate on its own initiative a minority interest will depend on all the circumstances of the case (including the likelihood of a public bid being launched), and in particular its belief as to the extent of the competition concerns that could potentially result from a minority shareholding.

<sup>64</sup> 'Warehousing' refers to a situation where a transferring business is temporarily acquired by an interim buyer, often a bank, on the basis of an agreement for the subsequent onward sale of the business to an ultimate acquirer.

<sup>65</sup> The CMA will apply similar principles to those set out in paragraphs 4.43 and 4.44 in the context of joint acquisitions for a start-up period.

- 4.42 The nature of the voluntary regime under the Act means there is, as a starting point, no requirement on the party or parties acquiring control under the first step in the above scenario to notify the CMA about the initial acquisition.
- 4.43 In terms of whether the CMA will investigate the initial acquisition on its own initiative, the CMA will generally be unlikely to do so where it is clear that it will be merely an interim step in the context of a wider transaction and that the subsequent steps will occur within the four-month time period within which the CMA has the ability to refer the initial acquisition. Where it appears that the subsequent steps may not take place within four months of the completion of the initial acquisition, the CMA will not risk losing its ability to refer the initial acquisition simply on the basis that it is intended that the current situation will not be permanent.
- 4.44 Where the initial acquisition is notified to it (whether the initial acquisition is anticipated or completed), the CMA would not be able to clear the transaction unconditionally simply on the basis that the situation as notified was not intended to be permanent. To avoid any referral for a phase 2 investigation that would otherwise be required on the basis of the initial acquisition, the CMA would require UILs (potentially effectively formalising in undertakings the merger parties' intended break-up).

## **Associated persons**

- 4.45 For the purposes of considering whether an enterprise has ceased to be distinct, [section 127](#) of the Act requires the CMA to consider whether a number of persons acquiring an enterprise are in fact 'associated persons' and thus should be viewed as acting together.
- 4.46 This situation will most commonly arise where the acquiring persons are related or have a signed agreement to act jointly to make an acquisition.<sup>66</sup> The Act does not require that each of the acquiring parties should themselves individually have control over the acquired entity for them all to be regarded as being associated persons.<sup>67</sup> Separate groups of enterprises may be

---

<sup>66</sup> See *Lebedev Holdings Limited and Another v Secretary of State for Digital, Culture, Media and Sport* [2019] CAT 21, at paragraph 30.

<sup>67</sup> See: *Groupe Eurotunnel SA v Competition Commission* [2013] CAT 30 at paragraph 57, *Groupe Eurotunnel SA v Competition and Markets Authority* [2015] CAT 1 at paragraph 79(c); and *Société Coopérative de Production SeaFrance SA v Competition and Markets Authority* [2015] UKSC 75 at paragraph 6.

associated persons where a single member that is an associated person to each of those groups is common to both groups.<sup>68</sup>

## Time limits for reference decisions

4.47 After starting an investigation, the CMA is in most cases required to decide whether the test for reference is met within a timetable of 40 working days,<sup>69</sup> failing which it loses its ability to refer the merger to a phase 2 inquiry. Where merger parties notify the CMA using a Merger Notice, that timetable (referred to in the Act as the 'initial period') starts on the first working day after the CMA confirms to the merger parties that the Merger Notice is complete.<sup>70</sup> In other cases, the timetable starts on the first working day after the CMA confirms that it has received sufficient information to enable it to begin its investigation.<sup>71</sup> The 40 working day deadline is subject to extension in certain circumstances,<sup>72</sup> and does not apply to decisions by the Secretary of State to refer a merger after issuing an intervention notice.

4.48 In addition, for the CMA to be able to refer a merger either:

- (a) the merger must not yet have taken place (that is, the parties must not yet have ceased to be distinct); or
- (b) under [section 24](#) of the Act, the completed merger must have taken place not more than four months before the reference is made, unless the merger took place without having been made public and without the CMA being informed of it (in which case the four-month period starts from the earlier of the time that material facts are made public or the time the CMA is told of material facts).

---

<sup>68</sup> See: *Lebedev Holdings Limited and Another v Secretary of State for Digital, Culture, Media and Sport* [2019] CAT 21 at paragraphs 66-67; CMA Report to the Secretary of State for Digital, Culture, Media and Sport: Completed acquisition by Mr. Sultan Muhammad Abduljadayel and Wondrous Investment Holdings L.P. of Independent Digital News and Media Limited and Lebedev Holdings Limited (28 June 2019); and OFT Decisions: Anticipated joint venture between The British Broadcasting Corporation, ITV Broadcasting Limited, Channel 4 Television Corporation, Channel 5 Broadcasting Limited, British Telecommunications plc, Talk Talk Telecoms Limited and Arqiva Limited – Project Canvas (19 May 2010); and Anticipated acquisition by Tramlink Nottingham Consortium of Net Phase 2 Concession (12 September 2011).

<sup>69</sup> If merger parties choose not to notify a completed merger, the initial period for the CMA's phase 1 investigation may be reduced to fewer than 40 working days by virtue of the four-month statutory deadline for a reference with which the CMA must also comply under the Act.

<sup>70</sup> [Section 34ZA\(3\)\(a\)](#) of the Act. A Merger Notice must meet the requirements set out in [section 96\(2\)](#) of the Act. Further information on notifying mergers to the CMA is set out in chapter 6 below.

<sup>71</sup> [Section 34ZA\(3\)\(b\)](#) of the Act.

<sup>72</sup> [Section 34ZB](#) of the Act. These include where relevant parties have failed to comply with the requirements of a formal information request under [section 109](#) of the Act and where the Secretary of State has served an intervention notice in relation to a merger which may raise public interest issues.

4.49 The test under the Act for when material facts are ‘made public’ is when they are ‘so publicised as to be generally known or readily ascertainable’.<sup>73</sup> In interpreting these provisions of the Act, the CMA will have regard to the following factors:

- (a) The CMA interprets ‘material facts’ as being the necessary facts that are relevant to the determination of the CMA’s jurisdiction in terms of the four-month time period (but not facts relevant to other aspects of whether a relevant merger situation exists for the purposes of the Act). In practice, this means information on the identity of the merger parties and whether the transaction remains anticipated (including the status of any conditions precedent to completion) or has completed.<sup>74</sup>
- (b) Where the merger parties do not notify the CMA, but ‘make public’ material facts about the transaction such that they are generally known or reasonably ascertainable, the CMA interprets this as meaning that such information could readily be ascertained by the CMA acting reasonably and diligently in accordance with its statutory functions. In practical terms, the CMA would consider that an acquiring party would normally be said to have ‘made public’ material facts where those facts had been publicised in the national<sup>75</sup> or relevant trade press<sup>76</sup> in the UK and where the acquiring party had itself taken steps to publicise the transaction at large, normally by publishing and prominently displaying on its own website a press release about the transaction.<sup>77</sup>

---

<sup>73</sup> [Section 24\(3\)](#) of the Act.

<sup>74</sup> See *Lebedev Holdings Limited and Another v Secretary of State for Digital, Culture, Media and Sport* [2019] CAT 21 at paragraphs 60, 64-68; CMA Report to the Secretary of State for Digital, Culture, Media and Sport: Completed acquisition by Mr. Sultan Muhammad Abduljadayel and Wondrous Investment Holdings L.P. of Independent Digital News and Media Limited and Lebedev Holdings Limited (28 June 2019). See also CMA Final Report: Completed acquisition by Ecolab Inc. of the Holchem Group Limited (8 October 2019) at paragraph 4.6 where a public announcement by Ecolab shortly after the Merger completed did not constitute material facts about the Merger being made public because the press release erroneously indicated that the Merger had not completed. See also the CC’s report: *Icopal Holding A/S and Icopal a/s: A report on the merger situation* (2001) at paragraph 2.50. That report concerned the application of the equivalent provisions of the Fair Trading Act 1973, but the result would not have differed under the Act.

<sup>75</sup> See *Lebedev Holdings Limited and Another v Secretary of State for Digital, Culture, Media and Sport* [2019] CAT 21, at paragraph 53.

<sup>76</sup> See CMA Decision: Completed acquisitions by Independent Vetcare Limited (IVC) of multiple independent veterinary businesses (17 February 2023), at paragraph 82.

<sup>77</sup> See OFT Decisions: Completed acquisition by Genus plc of Local Breeders Limited (14 May 2008) and Completed acquisition by Tesco Stores Limited of Brian Ford’s Discount Store Limited (22 December 2008). For a discussion of steps which were not considered by the CMA to give rise to material facts being made public, see CMA Final Report: Completed acquisition by Bottomline Technologies (de), Inc. of Experian Limited’s Experian Payments Gateway business and related assets (2020), at paragraph 5.26, CMA Decision: Completed acquisitions by Independent Vetcare Limited (IVC) of multiple independent veterinary businesses (17 February

- 4.50 The Act permits the CMA to extend the four-month time period in certain circumstances. When examining completed mergers, for example, the CMA may under [section 25](#) of the Act extend that period if an information request issued by it under [section 109](#) of the Act is not complied with (for example, information is not supplied within the stated deadline).<sup>78</sup>
- 4.51 As described at paragraph 4.38 above, [section 27\(5\)](#) of the Act allows the CMA to treat successive events within a period of two years between the same parties as occurring simultaneously on the date of the latest event.

## **The turnover test**

- 4.52 The ‘turnover test’ is met where the annual UK turnover of the enterprise being acquired exceeds £100 million.<sup>79</sup>

### ***Enterprise being acquired***

- 4.53 Under [section 28](#) of the Act, two types of situation may be distinguished for the purposes of calculating turnover: those where one or more enterprises remain under the same ownership and control after the merger as they were under before it, and those where no enterprise remains under the same ownership and control after the merger.
- 4.54 Where one or more enterprises remain under the same ownership and control after the merger, turnover is calculated by taking the total value of all enterprises ceasing to be distinct (that is, the acquiring entities and target entities) and deducting the turnover of those enterprises that remain under the same ownership and control after the merger.
- (a) This situation includes a straightforward acquisition, in which the acquirer (A) and the target (T) cease to be distinct from each other. The turnover of the acquirer is deducted as it remains under the same ownership and control after the merger. The relevant turnover is therefore that of the target. (See Figure 2A below.)
- (b) It also includes a situation where two or more companies (A and B) form a joint venture incorporating their assets and businesses in a particular area

---

2023), at paragraph 82, and CMA Decision: Completed acquisitions by Medivet Group Limited of multiple independent veterinary businesses (18 May 2023), at paragraph 83.

<sup>78</sup> Other circumstances in which the CMA can extend the four-month time period include, for example, by agreement with the merger parties and in certain circumstances following the giving of an intervention notice by the Secretary of State. See, in those respects, sections [25](#) and [42](#) of the Act.

<sup>79</sup> Section 23(1)(b) of the Act, as amended by the DMCC Act.

of activity. In this situation, each parent with control ceases to be distinct from the target business contributed to the joint venture by the other parent.<sup>80</sup> As all the parent companies remain under the same ownership and control after the merger,<sup>81</sup> and therefore have their turnover deducted, the turnover is the sum of the turnover of each of the contributed enterprises (which are, effectively, the target enterprises) ( $T_A$  and  $T_B$ ).<sup>82</sup> (See Figure 2B below.)

4.55 Where no enterprises remain under the same ownership and control after the merger, the relevant turnover is calculated by taking the total value of all enterprises ceasing to be distinct and deducting the turnover of the enterprise with the highest UK turnover.

(a) This includes a situation in which two enterprises (A and B) come together to form a full legal merger.<sup>83</sup> The relevant turnover would be that of the existing enterprise with the smaller UK turnover (B). (See Figure 2C below.)

(b) It also includes a situation in which two or more companies (A, B and C) form a joint venture (Newco) incorporating all of their assets and businesses. The relevant turnover would be that of all the existing companies, excluding the company with the largest UK turnover. (See Figure 2D below.)

---

<sup>80</sup> See CMA Decision: Anticipated joint venture between Anglican Water Group Ltd and Northumbrian Water Group Ltd (1 August 2017). See the CC's report: A report on the anticipated joint venture between BBC Worldwide Limited, Channel Four Television Corporation and ITV plc relating to the video on demand sector (2009), at paragraph 3.53.

<sup>81</sup> In certain cases, the CMA may treat entry into a joint venture as giving rise to more than one relevant merger situation (see footnote 19 above). In such a case, the CMA will treat the turnover of the enterprise being taken over as being the turnover of the enterprises contributed to the joint venture by the other parent(s).

<sup>82</sup> See OFT Decision: Anticipated relevant joint venture between Goodrich Corporation and Rolls-Royce plc (8 December 2008).

<sup>83</sup> A full legal merger occurs where a full merger of A and B as equals is achieved by Newco C acquiring both. In this circumstance, neither A nor B survives the merger. Both firms are brought under common control, but neither remains under the same control as it was pre-merger. The turnovers to be considered are those of A and B.

**Figure 2: Shaded areas mark those businesses to be included in the turnover calculation**

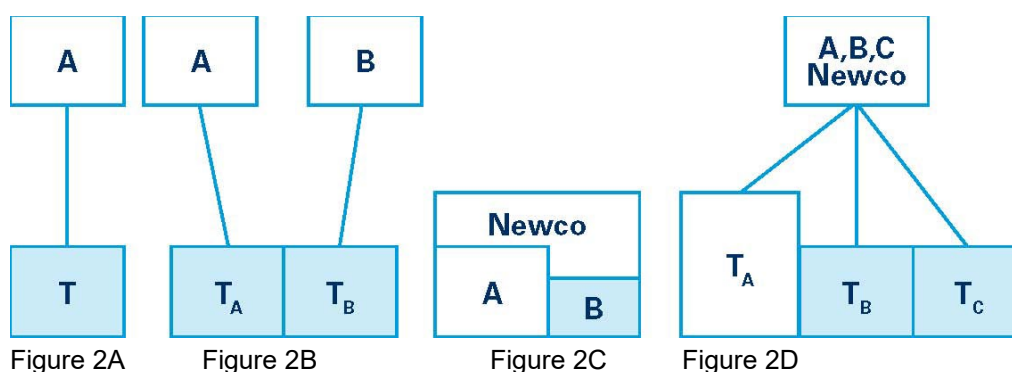

### **Calculation of turnover**

4.56 In principle, the turnover test applies to the turnover of the acquired enterprise that was generated in relation to customers within the UK<sup>84</sup> in the business year preceding the date of completion of the merger or, if the merger has not yet taken place, the date of the reference for a phase 2 investigation.<sup>85</sup> The figures in the enterprise’s latest published accounts will normally be sufficient to measure whether the turnover test is met, unless there have been significant changes since the accounts were prepared.<sup>86</sup> In this circumstance, more recent accounts would provide a better guide to the actual turnover of the enterprises concerned. Where company accounts do not provide a relevant figure, for example because only part of a business is being acquired or the accounts do not provide a suitable geographic breakdown of turnover, the CMA will consider evidence presented by the merger parties and other interested parties to form its own view as to what it believes to be the value of UK turnover for jurisdictional purposes.

4.57 The basic principles set out above are elaborated further in Appendix A.

<sup>84</sup> For the purpose of the geographic allocation of turnover, subject to complying with the [Enterprise Act 2002 \(Merger Fees and Determination of Turnover\) Order 2003 SI 2003/1370 \(as amended\)](#), the CMA will follow the approach set out in Appendix A. Subject to the qualifications outlined in Appendix A, the general rule is that turnover should be regarded as UK turnover for the purposes of the Act when the customer is located in the UK. The CMA will have regard to whether sales are made directly or indirectly (via agents or traders) to UK customers.

<sup>85</sup> In some cases, this may include intra-group sales (for example where a target business previously made intra-group sales, which would become external sales as a result of the acquisition of the target by a third party). See further Appendix A. Such considerations were relevant in OFT Decision: Anticipated joint venture between Vodafone Limited and Telefonica UK Limited (28 September 2012).

<sup>86</sup> In line with Article 11(3) of the [Enterprise Act 2002 \(Merger Fees and Determination of Turnover\) Order 2003 SI 2003/1370 \(as amended\)](#), the CMA would regard acquisitions or divestments or other transactions or events as relevant for these purposes, but considers that the gain or loss of individual customers would, absent exceptional circumstances, be unlikely to be relevant.



## The share of supply test

4.58 Under [section 23](#) of the Act, the ‘share of supply test’ is satisfied if:

- (a) at least one of the enterprises ceasing to be distinct has a UK turnover of more than £10 million;<sup>87</sup>
- (b) the enterprises ceasing to be distinct<sup>88</sup> either supply or acquire goods or services of a particular description in the UK;<sup>89</sup> and
- (c) the enterprises ceasing to be distinct will, after the merger,<sup>90</sup> supply or acquire 25% or more of those goods or services, in the UK as a whole or in a substantial part of it.

### *The safe harbour threshold*

4.59 Under the Act, a relevant merger situation will not arise if none of the enterprises concerned has a UK turnover exceeding £10 million (the ‘safe harbour’ threshold).<sup>91</sup>

4.60 See below for some examples of how the safe harbour threshold will apply in practice:

- (a) In a straightforward acquisition, where the acquirer (A) and the target (T) cease to be distinct from each other, T is the target enterprise and A is the ‘other enterprise concerned’. Therefore, the relevant turnovers for the purpose of the safe harbour threshold are the individual turnovers of A and T. Each of A and T will need to have a turnover of £10 million or less for the safe harbour threshold to apply.
- (b) In a situation where two or more companies (A and B) form a joint venture incorporating their assets and businesses in a particular area of activity (T1 and T2), T1 and T2 are the target enterprises and companies A and B are the ‘other enterprises concerned’. Therefore, the relevant turnovers

---

<sup>87</sup> Section 23(2)(c) of the Act introduced by the DMCC Act.

<sup>88</sup> Where more than two enterprises cease to be distinct, at least two of them must supply or acquire such goods or services.

<sup>89</sup> See, for example, CMA Decision: Anticipated acquisition by Roche Holdings, Inc. of Spark Therapeutics, Inc (10 February 2020) where the CMA found that the share of supply test was satisfied (on an alternative basis) based on the number of patents procured by the merger parties.

<sup>90</sup> In accordance with [section 23\(9\)](#) of the Act, the CMA assesses whether the share of supply test is met at the time of its decision on reference, unless the reference of an anticipated merger is subsequently treated by the CMA as being a reference of a completed merger pursuant to [section 37\(2\)](#) of the Act (in which case, it is at such time as the CMA may determine).

<sup>91</sup> Section 23(2)(c) of the Act introduced by the DMCC Act.

for the purposes of the safe harbour threshold are the sum of the turnover of T1 and T2,<sup>92</sup> the individual turnover of company A, and the individual turnover of company B. Each of T1+T2, company A, and company B will need to have a turnover of £10 million or less for the safe harbour to apply.

(c) In a situation where two enterprises (A and B) come together to form a full legal merger, the relevant turnovers for the purposes of the safe harbour threshold are the individual turnover of A and the individual turnover of B. Each of A and B will need to have a turnover of £10 million or less for the safe harbour to apply.

(d) In a situation where two or more companies (A, B and C) form a joint venture (Newco) incorporating all of their assets and businesses, the relevant turnovers for the purposes of the safe harbour threshold are the individual turnover of A, the individual turnover of B, and the individual turnover of C. Each of A, B and C will need to have a turnover of £10 million or less for the safe harbour to apply.

4.61 The turnover of the enterprise being taken over and any other enterprise concerned should be determined by applying the methodological principles set out at paragraphs 4.56 and 4.57 of this guidance (subject to the exception in paragraph 4.62 below).

4.62 One of the turnover calculation principles requires the aggregation of turnover of enterprises under common ownership or control (see paragraph 16 of Appendix A to this guidance). However, when calculating turnover for the purposes of the application of the safe harbour threshold in situations where, pre-merger, 'any other enterprise concerned' already controls (within the meaning of section 26 of the Act) the target enterprise, the turnover of the target is to be ignored when calculating the turnover of 'any other enterprise concerned'.<sup>93</sup> This is to avoid double counting the turnover of the target. For example:

(a) In a straightforward acquisition where, pre-merger, the acquirer (A) has de facto control over the target (T) and acquires legal control over T as a result of the merger, the turnover of T is to be excluded when calculating A's turnover for the purposes of the safe harbour threshold.

(b) In a situation where two or more companies (A and B) form a joint venture incorporating their assets and businesses in a particular area of activity

---

<sup>92</sup> See paragraph 4.54(b).

<sup>93</sup> Section 23(2B) of the Act introduced by the DMCC Act.

(A1 and B1), the turnover of the A1 is to be excluded when calculating A's turnover and the turnover of B1 is to be excluded when calculating B's turnover for the purposes of the safe harbour threshold.

### ***The supply or acquisition of goods or services of any description***

4.63 The Act confers on the CMA a broad discretion to identify, for the purposes of applying the share of supply test, a specific category of goods or services supplied or acquired by the merger parties.<sup>94</sup> In applying the share of supply test, the CMA will have regard to the following considerations:

- (a) The share of supply test is not an economic assessment of the type used in the CMA's substantive assessment; therefore, the group of goods or services to which the jurisdictional test is applied need not amount to a relevant economic market, and can aggregate, for example, intra-group and third party sales even if these might be treated differently in the substantive assessment.<sup>95</sup> As such, the description of goods or services to which the jurisdictional test is applied may differ from the relevant economic market used for the purposes of the substantive assessment of the merger.<sup>96</sup>
- (b) The CMA will have regard to any reasonable description of a set of goods or services to determine whether the share of supply test is met. Whilst the share of supply used may correspond with a standard recognised by the industry in question, this need not necessarily be the case.
- (c) The CMA will consider the commercial reality of the merger parties' activities when assessing how goods or services are supplied, focussing on the substance rather than the legal form of arrangements. Firms can engage in a variety of different business models and offer differentiated products or services, and the forms of supply which firms may offer in competition with one another can vary significantly. The CMA will consider whether there are sufficient elements of common functionality between

---

<sup>94</sup> [Section 23](#) of the Act. See *Sabre Corporation v Competition and Markets Authority* [2021] CAT 11, at paragraph 141, where the CAT held that the CMA has a broad discretion in both identifying categories of goods or services supplied or acquired by the merger parties and, also, the setting of any criteria used to identify when such goods or services can be treated as goods or services of a separate description.

<sup>95</sup> See CMA Decision: Anticipated acquisition by Roche Holdings, Inc. of Spark Therapeutics, Inc (10 February 2020) and OFT Decision: Anticipated acquisition by Montauban S.A. of Simon Group plc (21 August 2006).

<sup>96</sup> See CMA Decisions: Anticipated acquisition by Roche Holdings, Inc. of Spark Therapeutics, Inc (10 February 2020); Completed acquisition by ION Investment Group Limited of Broadway Technology Holdings LLC (7 July 2020); and Anticipated acquisition by LN-Gaiety Holdings Limited of MCD Productions Unlimited Company (11 July 2019).

the merger parties' activities.<sup>97</sup> Moreover, the CMA will take account of the life cycle of the supplies in question, noting that parties may have a material presence in the UK market by virtue of pipeline products or services,<sup>98</sup> or other factors.

- (d) In applying the share of supply test, the CMA may, under [section 23\(8\)](#) of the Act, apply such criteria as it considers appropriate to decide whether certain goods or services should be treated as goods or services of a separate description (and therefore not taken into account in assessing whether the share of supply test is met) in any particular case. The same approach applies to whether goods or services are of the same description.
- (e) The CMA cannot apply the share of supply test unless the merger parties together supply or acquire the same category of goods and services (of any description). The test cannot capture mergers where the relationship between the merger parties is purely vertical in nature and where there is no overlap between the merger parties' activities based on any reasonable description of a set of goods or services.<sup>99</sup>

### ***The UK or a substantial part of it***

- 4.64 The share of supply test requires that the merger has a sufficient UK nexus, namely, that it would result in the creation or enhancement of at least a 25% share of supply or acquisition of goods or services either in the UK or in a substantial part of the UK.
- 4.65 In assessing how goods or services are supplied in the UK, the CMA will have regard to the following considerations:
  - (a) The merger parties do not need to be legally incorporated in the UK.

---

<sup>97</sup> See CMA Decision: Anticipated acquisition by Visa International Service Association of Plaid Inc (24 August 2020); and CMA Final Report: Completed acquisition by Linergy of Ulster Farm By-Products (6 January 2016). See *Sabre Corporation v Competition and Markets Authority* [2021] CAT 11, at paragraphs 149 and 151, where the CAT held that an approach based on common functionality was appropriate and lawful.

<sup>98</sup> See CMA Decision: Anticipated acquisition by Roche Holdings, Inc. of Spark Therapeutics, Inc (10 February 2020).

<sup>99</sup> In CMA Decision: Completed acquisition by Google LLC of Looker Data Sciences, Inc. (13 February 2020), the share of supply test was applicable where parties were active at the same level of the supply chain, in addition to being vertically related. See also OFT Decisions: Completed acquisition by GFI Group Inc of Trayport Limited (28 May 2008); and Completed acquisition by the BUPA Group of the Cromwell Hospital (24 June 2008).

- (b) Services or goods are generally supplied in the UK where they are provided to customers which are located in the UK.<sup>100</sup> The CMA will apply this general rule in a flexible and purposive way, with regard to all relevant factors. In many circumstances, where competition with alternative suppliers takes place is likely to be informative. The CMA's assessment may also consider other factors, such as where relevant procurement decisions are likely to be taken or where the goods or services are ultimately delivered, supplied, accessed or used (for example, if the relevant goods or services are used to meet UK regulatory obligations) where appropriate. This general approach also applies in the case of sales to multinational companies, irrespective of place of incorporation, domicile or principal place of business.
- (c) The CMA will also have regard to the nature of the relationships between the merger parties and their customers (including as between different customer groups). While the CMA will consider direct contractual relationships, it may also consider customer relationships that are not governed by contract,<sup>101</sup> as well as other relevant factors.<sup>102</sup> For example, under [section 128](#) of the Act, the supply of services includes the provision of services by making them available to potential users,<sup>103</sup> and making arrangements for the use of computer software.<sup>104</sup>

### *Substantial part of the UK*

4.66 The share of supply test may be applied to the UK as a whole or to a substantial part of it. The test may be satisfied on the basis of the share of supply or acquisition in a relatively wide geographic area (such as the UK, Great Britain, England, Scotland, Wales or Northern Ireland), even if the

---

<sup>100</sup> The mere fact that a supplier is located in the UK is therefore not conclusive that services are being supplied in the UK. Conversely, suppliers based overseas may be supplying services in the UK.

<sup>101</sup> In some cases, interactions between firms and their customers might not be reduced to single (formal) 'procurement' decisions giving rise to direct contractual relationships, and it may be necessary to consider the significance of commercial relationships in the round. See, for example, CMA Decision: Anticipated acquisition by Evolution Gaming Group AB of NetEnt AB (8 December 2020).

<sup>102</sup> For example, see *Sabre Corporation v Competition and Markets Authority* [2021] CAT 11, paragraph 241, where the CAT held that an agreement between a UK based customer and a non-UK based merger party for the creation of a technical connection to enable communication between the customer's IT system and the merger party, in conjunction with the surrounding arrangements and facts of that case, meant that the customer was supplied with services by the merger party in the UK.

<sup>103</sup> [Section 128\(3\)](#) of the Act. See CMA Request pursuant to article 22 of Council Regulation (EC) 139/2004: Anticipated acquisition by Mastercard Incorporated of Parts of the Corporate Services Business of Nets A/S (16 March 2020).

<sup>104</sup> [Section 128\(4\)](#) of the Act. See CMA Decision: Completed acquisition by ION Investment Group Limited of Broadway Technology Holdings LLC (7 July 2020).

transaction's competitive impact is more likely to be regional or local in nature.<sup>105</sup>

- 4.67 There is no statutory definition of 'a substantial part'. The House of Lords (now the Supreme Court of the UK) ruled in the context of similar provisions in the Fair Trading Act 1973 that, while there can be no fixed definition, the area or areas considered must be of such size, character and importance as to make it worth consideration for the purposes of merger control.<sup>106</sup> The CMA will take such factors into account as: the size, population, social, political, economic, financial and geographic significance of the specified area or areas, and whether it is (or they are) special or significant in some way.<sup>107</sup>
- 4.68 There is no need in the application of the share of supply test for the substantial part of the UK to constitute an undivided geographic area. This interpretation gives effect to the purposes of the Act. The economic significance of a merger, in terms of an SLC, does not necessarily depend on whether several localities are contiguous or separated.<sup>108</sup>

### **The 25% threshold**

- 4.69 Under section 23(3) and 23(4) of the Act, the share of supply test is satisfied where the merger will result in a share of supply of 25% or more in relation to the supply of goods or services of any description in the UK or in a substantial part of the UK.
- 4.70 Accordingly, where an enterprise already supplies or acquires 25% of any particular goods or services, the test is satisfied so long as its share is

---

<sup>105</sup> See CMA Final Report: Anticipated acquisition by LN-Gaiety Holdings Ltd of MCD Productions Unlimited Company (19 December 2019).

<sup>106</sup> See *Regina v Monopolies and Mergers Commission and another ex parte South Yorkshire Transport Limited* [1993] 1 WLR 23, at paragraphs 31A to 32B: '... the epithet "substantial" is there to ensure that the expensive, laborious and time-consuming mechanism of a merger reference is not set in motion if the effort is not worthwhile... [To be a substantial part of the UK] the part must be of such size, character and importance as to make it worth consideration for the purposes of the Act'.

<sup>107</sup> See CMA Decisions: Completed acquisition by Novo Invest GmbH acting through Novomatic UK Ltd of Talarius Limited (28 October 2016); Completed acquisition by Co-operative Foodstores Limited of eight My Local grocery stores from ML Convenience Limited and MLCG Limited (19 October 2016); Anticipated acquisition by Co-operative Foodstores Limited of 15 Budgens grocery stores from Booker Retail Partners (GB) Limited (6 June 2016); Completed acquisition by LN-Gaiety Holdings Limited of MAMA & Company Limited (19 February 2016); and Completed acquisition by Oasis Dental Care (Central) Limited of Total Orthodontics Limited (2 September 2015).

<sup>108</sup> See CMA Decisions: Completed acquisition by Henderson Retail Limited of part of the Martin McColl Limited portfolio (16 February 2018); Completed acquisition by Novo Invest GmbH acting through Novomatic UK Ltd of Talarius Limited (28 October 2016); and CC's report: A report on the acquisition by Archant Limited of the London newspapers of Independent News and Media Limited (22 September 2004).

increased as a result of the merger, regardless of the size of the increment.<sup>109</sup> Where there is no increment, the share of supply test is not met (subject to the exceptions and special regimes described below).

4.71 In applying the share of supply test, the CMA may under [section 23\(5\)](#) of the Act have regard to the value,<sup>110</sup> cost, price, quantity, capacity, number of workers employed<sup>111</sup> or any other criterion, or combination of criteria, in determining whether the 25% threshold is met.<sup>112</sup>

## The hybrid test

4.72 The hybrid test is satisfied where, pre-merger:<sup>113</sup>

- (a) the person(s) that carry on one of the enterprises concerned supply or acquire at least 33% of goods or services of any description in the UK (or a substantial part of the UK) taking into account the activities of both the enterprise concerned or any enterprise concerned with which the enterprise concerned is under common ownership or control;<sup>114</sup> and
- (b) the same enterprise concerned has a UK turnover in excess of £350 million;<sup>115</sup> and
- (c) any other enterprise concerned meets one of the following conditions:<sup>116</sup>

---

<sup>109</sup> See, for example, CMA Final Report: Anticipated acquisition by LN-Gaiety Holdings Ltd of MCD Productions Unlimited Company (19 December 2019). See *Sabre Corporation v Competition and Markets Authority* [2021] CAT 11, where the CAT held (at paragraph 306) that there is no *de minimis* threshold when assessing the increment and, also, (at paragraph 302) that it is not always necessary for the CMA to attribute a specific numerical value to the increment.

<sup>110</sup> See *Sabre Corporation v Competition and Markets Authority* [2021] CAT 11, at paragraph 310, where the CAT held that the existence of the contractual right to payment gives rise to a quantitative measure of value for the purpose of [section 23](#) of the Act.

<sup>111</sup> See CMA Decision: Anticipated acquisition by Roche Holdings, Inc. of Spark Therapeutics, Inc (10 February 2020).

<sup>112</sup> In the CMA Decision: Anticipated acquisition by Roche Holdings, Inc. of Spark Therapeutics, Inc (10 February 2020), the CMA relied on the number of patents procured by the merger parties as an alternative basis to satisfy the share of supply test. In CMA Request pursuant to article 22 of Council Regulation (EC) 139/2004 in Anticipated acquisition by Mastercard Incorporated of Parts of the Corporate Services Business of Nets A/S (16 March 2020), the CMA considered that the share of supply test would be met based on the number of suppliers bidding to supply certain services.

<sup>113</sup> Section 23(4C) of the Act introduced by the DMCC Act.

<sup>114</sup> Section 23(4D) of the Act introduced by the DMCC Act.

<sup>115</sup> Section 23(4E) of the Act introduced by the DMCC Act.

<sup>116</sup> Sections 23(4F) and (4G) of the Act introduced by the DMCC Act.

- (i) the enterprise is carried on by a body of persons corporate or unincorporate formed or recognised under the law of any part of the UK; or
- (ii) the activities, or part of the activities, of the enterprise are carried on in the UK; or
- (iii) the person, or persons, by whom the enterprise is carried on supply goods or services to a person or persons in the UK in connection with the enterprise.

4.73 The hybrid test may be satisfied in relation to horizontal mergers, but also, for example, in relation to vertical or conglomerate mergers where the parties are not active at the same level of the market.

4.74 Each condition of the new hybrid test is explained below. See below some examples of how the hybrid test will apply in practice:

- (a) In a straightforward acquisition where there are two enterprises concerned (ie the acquirer (A) and the target (B)), the hybrid test will be satisfied if, for instance, pre-merger, (A) has a UK share of supply of at least 33% and a UK turnover in excess of £350 million, and (B) has a UK nexus.
- (b) In a situation where two or more companies (A and B) form a joint venture incorporating their assets and businesses in a particular area of activity (A1 and B1), the hybrid test will be satisfied if, for instance, pre-merger, A has a UK share of supply of at least 33% and a UK turnover in excess of £350 million, and B1 has a UK nexus.
- (c) In a situation where two enterprises (A and B) come together to form a full legal merger, the hybrid test will be met if, for instance, pre-merger, A has a UK share of supply of at least 33% and a UK turnover in excess of £350 million, and B has a UK nexus.

### ***Share of supply and turnover conditions***

4.75 Both the share of supply and turnover conditions of the hybrid test must be satisfied by one and the same enterprise concerned. The Act does not distinguish between acquiring and acquired enterprises for the purposes of satisfying these conditions. However, the hybrid test is described as ‘acquirer focused’<sup>117</sup> which reflects the fact that, in practice, transactions where the

---

<sup>117</sup> As confirmed in the DMCC Act Explanatory Notes, paragraph 46.



enterprise being acquired has a UK turnover exceeding £350 million (the turnover condition under the 'hybrid test') would also satisfy the standard turnover test<sup>118</sup> which does not require an assessment of the share of supply condition.

- 4.76 In situations involving more than one acquiring enterprise, the same entity on the acquirer side will need to satisfy the share of supply and turnover conditions. For instance, if enterprises A and B together acquire enterprise C, and enterprise C has a UK nexus, the hybrid test will be satisfied if one of A or B meets both the share of supply and turnover conditions. The application of the share of supply and turnover conditions will be assessed on a case-by-case basis in situations involving complex transaction structures.
- 4.77 The share of supply and turnover conditions applicable to the hybrid test are considered in turn below.

#### *Share of supply condition*

- 4.78 The share of supply condition of the hybrid test will be satisfied if, pre-merger, the person(s) that carry on the acquiring enterprise supply or acquire at least 33% of goods or services of any description in the UK or a substantial part of it, taking into account the activities of both the enterprise concerned or any enterprise concerned with which the enterprise concerned is under common ownership or control.<sup>119</sup>
- 4.79 In assessing whether the acquiring enterprise satisfies this condition, the standard principles set out in this guidance in relation to the share of supply test will be followed in the application of the hybrid test, with the exception of the principles requiring the need to establish an overlap<sup>120</sup> or an increment.<sup>121</sup>

#### *Turnover condition*

- 4.80 The turnover condition under the hybrid test will be satisfied if, pre-merger, the acquiring enterprise has a UK turnover which exceeds £350 million. The calculation of the turnover of the acquiring enterprise should follow the methodological principles set out at paragraphs 4.56 and 4.57 in the context of the turnover test.

---

<sup>118</sup> The turnover test is set out in section 23(2)(b) of the Act (as amended by the DMCC Act) and explained in paragraphs 4.52 to 4.57 of this guidance.

<sup>119</sup> Section 23(4D) of the Act.

<sup>120</sup> Paragraph 4.63(e).

<sup>121</sup> Paragraphs 4.64, 4.69, and 4.70.

### ***UK nexus condition***

- 4.81 The UK nexus condition of the hybrid test will generally apply to the target enterprise (based on pre-merger conditions).<sup>122</sup> This is to ensure that the merger has a ‘sufficient connection with the UK.’<sup>123</sup>
- 4.82 In order to give effect to the hybrid test, which was established to provide a more comprehensive and effective jurisdictional basis to review mergers involving potential competition or dynamic competition,<sup>124</sup> the CMA applies a purposive approach to the UK nexus condition.
- 4.83 The different limbs of the UK nexus condition are considered in turn below. If any of these limbs is met, the enterprise concerned has a sufficient UK nexus for the purposes of the hybrid test.

#### *The enterprise is carried on by a UK body of persons*

- 4.84 The first limb of the UK nexus condition is satisfied if, pre-merger, any enterprise concerned, other than the enterprise satisfying the share of supply and turnover conditions, is carried on by a body of persons corporate or unincorporate formed or recognised under the law of any part of the UK.
- 4.85 The CMA considers that this limb is met where the enterprise carries on any of its activities through a body of persons corporate or unincorporate (eg companies or partnerships) formed or recognised under the law of any part of the UK.
- 4.86 Where the enterprise comprises assets only, this limb will not be satisfied.

#### *At least part of its activities are carried on in the UK*

- 4.87 The second limb of the UK nexus condition is met if, pre-merger, the activities, or part of the activities, of any enterprise concerned, other than the enterprise satisfying the share of supply and turnover conditions, are carried on in the UK. For this limb to be satisfied, there needs to be an activity being carried on in, or partly in, the UK.
- 4.88 This limb is separate from the requirement to supply products or services in the UK considered below. As such, the CMA considers that, for it to be met,

---

<sup>122</sup> The target enterprise includes an enterprise which, as a result of the merger, is brought under the control of the acquiring enterprise by virtue of section 26(4) of the Act (section 23(4G)(b) introduced by the DMCC Act).

<sup>123</sup> Explanatory Notes, paragraph 540(d).

<sup>124</sup> As set out in the Explanatory Notes, paragraph 536.

there is no need for the acquired entity to be supplying any goods or services in the UK at the time of the merger. Where any element of an enterprise concerned is in the UK, or any preparatory step<sup>125</sup> has been taken in the UK by an enterprise concerned towards supplying goods or services in the UK, this will be relevant in determining whether this limb is satisfied.

- 4.89 An enterprise may carry on at least part of its activities in the UK if, for example, it has an office, branch or any kind of facility in the UK; has a business in the UK; has intellectual property rights in the UK; has obtained a licence or regulatory approval to enable it to supply goods or services (whether directly or indirectly) in the UK; or the enterprise makes available its goods or services to consumers in the UK.<sup>126</sup>

*It supplies goods or services to a person or persons in the UK*

- 4.90 The third limb of the UK nexus condition will be met if, pre-merger, the person(s), by whom the enterprise concerned is carried on, supply (directly<sup>127</sup> or indirectly<sup>128</sup>, for consideration or otherwise) goods or services to a person or persons in the UK in connection with the enterprise concerned.<sup>129</sup> For a person to be supplying goods or services to a person(s) in the UK there need to be goods or services being provided from one person to another, and the recipient needs to be in the UK.

- 4.91 The CMA notes, in this regard, that the supply of services includes (amongst others):

- (a) the supply of digital content;
- (b) the supply of digital services by means of the internet;
- (c) rendering services to order;
- (d) the provision of services by making them available to potential users; and

---

<sup>125</sup> For instance, steps going beyond mere feasibility studies taken outside the UK.

<sup>126</sup> Where an overseas enterprise makes available its goods or services to UK consumers and actively targets UK consumers (eg through a UK website, advertising, or tailoring products/services for UK customers), the CMA would expect to find that the enterprise carries on activities in the UK.

<sup>127</sup> Eg through employees.

<sup>128</sup> The person needs to be sufficiently involved in that supply to be said to be making the supply, whether alone or with others, for example through a subsidiary or an agent.

<sup>129</sup> For example, this would generally include an overseas company that produces goods for exporting to a company in the UK or is responsible for distributing them to the UK company.

- (e) making arrangements for the use of computer software or for granting access to data stored in any form which is not readily accessible.<sup>130</sup>

## Exceptions and special regimes

- 4.92 No increment is required in relation to the shares of supply of newspapers and/or broadcasting where the Secretary of State issues a special intervention notice (see paragraph 14.14 below).
- 4.93 For mergers involving two or more 'water enterprises' or two or more 'energy networks' the jurisdictional test is based on turnover only (see paragraphs 15.1 and 15.2 below for further information).
- 4.94 The increase in the share of supply (referred to in paragraph 4.70) must result from the enterprises ceasing to be distinct. In the case of an acquisition, this requires calculation of the share of supply based on the activities of the acquirer and the target company. In joint venture situations, the share of supply is calculated by reference to the activities of the joint venture, although it will include shares of the controlling joint venture parents where they remain active in the same activities as the joint venture. For example, where two companies, Company A and Company B, form a joint venture incorporating their assets and businesses in a particular area of activity, enterprises T<sub>A</sub> and T<sub>B</sub> respectively, the share of supply test is applied with reference to whether there is an increase in the share of supply between A, B, T<sub>A</sub> and T<sub>B</sub> in relation to the areas of activity in which T<sub>A</sub> and/or T<sub>B</sub> are active. The CMA would therefore not apply the share of supply test as between A and B outside the areas of activity of the joint venture.

---

<sup>130</sup> See sections 128(3) and (4) of the Act.

## 5. The phase 1 process: overview

- 5.1 Table 1 below shows the key stages – and indicative timing – of a typical phase 1 investigation by the CMA, together with a high-level summary of the actions that are typically taken by the CMA<sup>131</sup> and by the merger parties (and, where relevant, third parties) at each stage.
- 5.2 As noted in Table 1, certain actions (for example, information gathering, the imposition of interim measures, or engagement with the CMA on potential remedies) may in practice occur at various stages of the phase 1 process, including prior to the formal commencement of the investigation timetable. The CMA will apply a reasonable and proportionate approach to these actions according to the complexity of the issues under investigation.
- 5.3 Each of the stages is described in more detail in chapters 6 to 9 below.

---

<sup>131</sup> Table 1 does not show the statutory functions performed by Ofcom, NHS England or the Secretary of State in relation to, respectively, local media mergers, NHS mergers and public interest mergers nor does it show the responsibilities of the CMA in respect of these types of merger (see further chapters 9 and 14 below).

**Table 1: The key stages of a typical phase 1 investigation**

	MILESTONES	CMA	PARTIES
<b>STAGE 1: Initial discussions commence between merger parties and CMA (for merger parties wishing to submit a voluntary notification)</b>			
Typically, minimum of 2 weeks before initial submission of draft notification	Initial contact between merger parties and CMA	CMA allocates case team of CMA staff to review transaction and liaise with merger parties.	Merger parties engage in initial contact with CMA and submit a case team allocation request form.
<b>STAGE 2A: Pre-notification discussions begin (where transaction is voluntarily notified by merger parties)<sup>132</sup></b>			
Duration of pre-notification process will differ on case-by-case basis; cases raising complex and/or <i>prima facie</i> competition concerns will typically entail a longer pre-notification period	Pre-notification process begins	<p>CMA case team engages with merger parties on the nature and scope of information and internal documents which the case team considers the merger parties will need to provide in their voluntary notification.</p> <p>For some mergers, it may also be appropriate for the case team to hold informal discussions on remedies with the merger parties at any point from the start of the pre-notification process onwards.</p>	<p>Merger parties respond to CMA information requests.</p> <p>Merger parties may also wish to signal to the CMA at this stage that they wish to engage in early remedies discussions or pursue a 'fast-track' process (eg to proceed more quickly to offering remedies or to a phase 2 investigation).</p>
	Merger parties submit voluntary notification (Merger Notice)	<p>CMA continues pre-notification discussions and reviews draft Merger Notice.</p> <p>CMA will typically issue information requests (including statutory requests under section 109 of the Act) to the merger parties to complete the notification and ensure that the CMA has sufficient information to commence its investigation.</p> <p>CMA is also likely to engage with third parties and may issue a public invitation to comment, inviting submissions about the potential competitive impact of the merger. Once CMA is satisfied that the Merger Notice is in the form, and contains the information, required by the Act, it confirms this to the merger parties, and confirms the consequent statutory deadline for its phase 1 decision.</p> <p>CMA considers whether interim measures are necessary to prevent or</p>	<p>Merger parties submit a Merger Notice, usually in draft form.</p> <p>Merger parties respond to any information requests and submit updated drafts of voluntary notification as appropriate.</p> <p>Merger parties submit completed Merger Notice.</p> <p>Third parties respond to requests for information (in writing or orally) and/or to any invitation to comment.</p>

<sup>132</sup> For information regarding submission of a 'briefing note' to the CMA's mergers intelligence function, see *Guidance on the CMA's mergers intelligence function* (CMA56).

	MILESTONES	CMA	PARTIES
		unwind pre-emptive action – in some cases, this may be before submission of the voluntary notification. <sup>133</sup>	
<b>STAGE 2B: Own initiative investigation (where transaction is not voluntarily notified by the merger parties)</b>			
	CMA becomes aware of a transaction that has not been voluntarily notified	<p>CMA considers whether there is a reasonable chance that its duty to refer would be met if it investigated the transaction.</p> <p>Where appropriate, CMA sends an enquiry letter to the merger parties requesting further information about the transaction.</p> <p>CMA also likely to engage third parties and may issue a public invitation to comment, inviting submissions about the potential competitive impact of the merger.</p> <p>CMA considers whether interim measures are necessary to prevent or unwind pre-emptive action.</p> <p>When CMA has sufficient information to begin its investigation, it confirms this to the merger parties, and confirms the consequent statutory deadline for its phase 1 decision.</p>	<p>Merger parties respond to enquiry letter and provide CMA with requested information.</p> <p>Third parties respond to requests for information (in writing or orally) and/or to any invitation to comment.</p>
<b>STAGE 3: Phase 1 assessment</b>			
Working Day 1		The 40 working day initial period for the CMA's phase 1 investigation begins on the first working day after it confirms to the merger parties that it has received a complete Merger Notice or that it has sufficient information to begin its investigation.	
	Information-gathering	<p>CMA continues to engage with merger parties as appropriate throughout the 40 working day period.</p> <p>CMA requests further information from merger parties (if necessary)</p>	<p>Ongoing liaison between case team and merger parties.</p> <p>Merger parties respond to any information requests.</p>

<sup>133</sup> The Act permits the CMA to make initial enforcement orders (IEOs), including unwinding orders, at any stage of the phase 1 investigation process (including prior to the formal commencement of its phase 1 investigation), in order to prevent action which may prejudice any reference to phase 2 or impede any action by the CMA which may be justified by its findings following a phase 2 investigation.

	MILESTONES	CMA	PARTIES
		during the 40 working day period.  CMA may also directly contact third parties to seek views and information relevant to the assessment of the transaction. <sup>134</sup>	Third parties respond to any requests for information.
	Invitation to comment	CMA publishes invitation to comment notice, inviting views from interested third parties on the transaction under review.  CMA assesses responses from third parties.	Third parties respond to invitation to comment.
Working Day 15 – 20	State of play discussion	CMA holds 'state of play' discussion with merger parties (typically by videoconference).	Merger parties participate in state of play discussion.
<b>STAGE 4A: Phase 1 decision-making process (for cases raising no serious competition concerns)</b>			
By Working Day 40	Phase 1 decision	CMA clears transaction.  CMA drafts clearance decision and communicates this to the merger parties.  CMA publicly announces clearance decision (full decision published at a later date following identification of confidential information).	
<b>STAGE 4B: Phase 1 decision-making process (for cases raising more complex or material competition issues)</b>			
By Working Day 40	Issues Meeting  (Typically held by Working Day 25)	CMA invites merger parties to issues meeting.  CMA sends merger parties 'issues letter' stating core arguments for reference to phase 2.  CMA holds 'issues meeting' with merger parties.	Merger parties may provide written response to issues letter (before and/or after issues meeting).  Merger parties attend issues meeting, in person or via videoconference.
	Phase 1 decision	CMA holds internal 'Case Review Meeting'.  CMA holds internal decision meeting. The CMA's phase 1 decision maker decides whether duty to refer has been met.	

<sup>134</sup> In some cases, the CMA may contact third parties and/or publish an invitation to comment notice during the pre-notification stage.



	MILESTONES	CMA	PARTIES
	Notice of decision	<p>CMA provides merger parties with its reasoned decision within statutory period.</p> <p>CMA publishes notice of decision (full decision published at a later date following identification of confidential information).</p>	
<b>STAGE 5: Phase 1, potential remedies – where CMA decides duty to refer is met</b>			
0-5 working days after merger parties given decision	Offer of undertaking in lieu of reference (UILs)		<p>Merger parties decide whether to offer UILs to remedy identified concerns.</p> <p>Merger parties who do wish to offer UILs submit completed Phase 1 Remedies Form and draft UILs to CMA.</p>
Up to 10 working days after merger parties given decision	Consideration of offered UILs	<p>If no UILs offered within five working day period, CMA refers transaction to phase 2.</p> <p>CMA considers any UILs offered.</p> <p>CMA decides whether to provisionally accept UILs (or a modified version of them).</p> <p>If CMA rejects UILs, transaction is referred to phase 2.</p>	Merger parties respond to any modifications to the UILs proposed by the CMA.
Within 50 working days of merger parties being given decision (subject to extension for special reasons)	Agreement and acceptance of UILs	<p>CMA gives detailed consideration to terms of proposed UILs to determine if any modifications required before they can be finally accepted.</p> <p>CMA publishes draft UILs for third party comment.</p> <p>CMA considers whether to formally accept draft UILs (with possible further, shorter consultation if required following any material changes to the UILs).</p> <p>If UILs are considered sufficiently 'clear cut' and effective, the CMA publishes a notice of acceptance of UILs.</p> <p>If UILs are not agreed, transaction is referred to phase 2.</p>	<p>Merger parties discuss any necessary modifications to the UILs so as to agree a version for publication for third party consultation.</p> <p>Third parties submit comments on draft UILs within consultation period (at least 15 calendar days for the initial consultation, and at least seven calendar days for any subsequent consultation).</p> <p>If CMA agrees UILs, merger parties sign UILs.</p>

	<b>MILESTONES</b>	<b>CMA</b>	<b>PARTIES</b>
	Implementation of UILs if agreed	<p>CMA publishes final UILs.</p> <p>CMA assesses, and as appropriate approves, proposed purchaser(s) of the business(es) being divested by merger parties (will occur prior to acceptance of UILs in 'upfront buyer' cases).</p>	<p>Merger parties implement UILs, including (where no upfront buyer was required) submitting for CMA approval details of proposed purchasers of any divestments required under the UILs.</p>

## 6. Notification of mergers to the CMA

- 6.1 Under the Act, there is no requirement to notify mergers to the CMA. Notification to the CMA is therefore described as ‘voluntary’,<sup>135</sup> in contrast to the situation in most other jurisdictions. The CMA does not, for the purposes of substantive competition assessment, treat completed acquisitions any differently to anticipated transactions.<sup>136</sup> However, as described in this chapter, there can be significant benefits to merger parties notifying a merger to the CMA and/or engaging in early discussions with the CMA as to whether they should notify a merger, particularly in the case of transactions which may be notifiable across multiple jurisdictions.
- 6.2 In cases that constitute a relevant merger situation, but where competition concerns clearly do not arise, the merger parties may decide that notification to the CMA is not necessary.
- 6.3 However, in cases that do raise the possibility of competition concerns, parties should consider carefully whether to notify the merger to the CMA. In making this choice, they should be aware that:
- (a) the CMA may well become aware of the transaction as a result of its own mergers intelligence functions (including through the receipt of complaints); and
  - (b) a decision not to notify the CMA carries particular risks once the merger has been completed.

These considerations are discussed in turn below.

---

<sup>135</sup> The merger parties may, however, be asked to provide sufficient information for the CMA to be able to review the merger, if the CMA chooses to investigate on its own initiative.

<sup>136</sup> A number of cases referred by the CMA for a phase 2 investigation have been ones which the merger parties did not voluntarily notify, but which the CMA decided to investigate on its own initiative or following a complaint from a third party. See, for example, CMA Decisions: Completed acquisition by Facebook, Inc (now Meta Platforms, Inc) of Giphy, Inc. (18 October 2022); Completed acquisition by JD Sports Fashion plc of Footasylum plc (6 May 2020); Completed acquisition by Tobii AB of Smartbox Assistive Technology Limited and Sensory Software International Ltd (25 January 2019); and Completed acquisition by Vanilla Group Limited (JLA) of Washstation Limited (3 April 2018). In other such cases, the CMA has accepted undertakings in lieu of reference for a phase 2 investigation. See, for example, CMA Decisions: Completed acquisition by Scooby Bidco Limited, trading through its subsidiary VETPartners Limited of Goddard Holdco Limited (2 September 2022); Completed acquisition by ION Investment Group Limited of Broadway Technology Holdings LLC (10 November 2020); Completed acquisition by Danspin A/S of certain assets and goodwill of LY Realisations Limited (previously known as Lawton Yarns Limited) (12 March 2020).

## The CMA's mergers intelligence function

- 6.4 The fact that a merger has not been voluntarily notified to the CMA does not mean that the CMA will not review it. The CMA has a duty to track merger activity to determine whether any unnotified merger may give rise to an SLC. In addition, there is a requirement on undertakings designated as having strategic market status to report certain mergers to the CMA before completion.<sup>137</sup> The CMA will take a decision to investigate if it believes that there is a reasonable chance that the test for a reference to an in-depth phase 2 investigation will be met (ie there is a reasonable chance that an investigation will identify a relevant merger situation that gives rise to a realistic prospect of an SLC).
- 6.5 The CMA has dedicated mergers intelligence staff responsible for monitoring non-notified merger activity. Any interested party that wishes to make the CMA aware of a merger that it considers could raise competition concerns can also contact the CMA confidentially at [Mergers.Intelligence@cma.gov.uk](mailto:Mergers.Intelligence@cma.gov.uk).
- 6.6 Further information about the operation of the CMA's mergers intelligence function is provided in the CMA's [Guidance on the CMA's mergers intelligence function \(CMA56revised\)](#).

## Risks to the merger parties of not notifying and/or completing mergers

- 6.7 The fact that a merger has been completed does not prevent the CMA from investigating and referring it for a phase 2 investigation for possible remedial action, or accepting UILs. For non-notified completed mergers, the CMA will generally seek to prevent pre-emptive action which might prejudice the reference or impede any action by the CMA which may be justified by its findings through its powers to make an initial enforcement order (IEO). Where it decides to make such an order, the CMA will notify the merger parties that it has made an IEO under [section 72](#) of the Act that prevents them from starting integration (or undertaking further integration) at the same time as it sends the enquiry letter, or shortly thereafter.
- 6.8 In considering whether to notify a merger to the CMA, merger parties should note, in the context of completed mergers, that:

---

<sup>137</sup> The reporting requirement has been introduced by the DMCC Act (Part 1, Chapter 5). For further information on the reporting requirement, see *Guidance on the mergers reporting requirement for SMS firms* (CMA 195).

- (a) First, the CMA will normally issue IEOs<sup>138</sup> in investigations where it has reasonable grounds for suspecting that two or more enterprises have ceased to be distinct.<sup>139</sup> An IEO is intended to prevent any action (for example, integration of the merging businesses) that might prejudice the reference to a phase 2 investigation and/or impede any action by the CMA which may be justified by its findings. An IEO will remain in force until the merger is cleared or remedial action is taken, unless varied, revoked or replaced.<sup>140</sup> In certain circumstances, the CMA may consider it necessary to use its powers to unwind integration that has already occurred prior to the IEO coming into force. This will also be assessed on a case-by-case basis, where the CMA reasonably suspects that action has, or may have, been taken which constitutes pre-emptive action. See [Interim measures in merger investigations \(CMA108\)](#) for further information about IEOs.
- (b) Second, completing a merger without first obtaining clearance from the CMA carries the risk that the CMA may order the disposal of the acquired business (or otherwise the disposal of other businesses or assets) following an investigation. This has occurred under the Act in a number of cases.<sup>141</sup> The fact that a merger has been completed does not reduce the likelihood of the CMA referring the merger to phase 2 or of implementing remedies (which will typically be structural in nature). When considering remedies in the context of a completed merger, the CMA will not normally consider the costs of divestment to the merger parties as it is open to the merger parties to make merger proposals conditional on competition authorities' approval.<sup>142</sup>

---

<sup>138</sup> [Section 72](#) of the Act. Such orders may also require the appointment, at the cost of the merger parties, of a hold separate manager and/or monitoring trustee to oversee the order.

<sup>139</sup> This is a lower threshold than having reasonable grounds for suspecting that a relevant merger situation has been created, since it does not require the turnover or share of supply jurisdictional tests to be met (see chapter 4 above).

<sup>140</sup> An IEO made at phase 1 will be reassessed in the event of a reference to phase 2, and additional or alternative safeguards may be put in place (for example, to prevent the target business from deteriorating during the phase 2 investigation).

<sup>141</sup> See, for example, Completed acquisition by Facebook, Inc (now Meta Platforms, Inc) of Giphy, Inc. (18 October 2022); Completed acquisition of 3G Truck & Trailer Parts Limited by TVS Europe Distribution Limited (17 November 2020); and Completed acquisition by JD Sports Fashion plc of Footasylum plc (6 May 2020); Completed acquisition by Tobii AB of Smartbox Assistive Technology Limited and Sensory Software International Ltd (25 January 2019); Completed acquisition by Danspin A/S of Lawton Yarns Limited (5 November 2019); Completed acquisition by Ecolab Inc. of Holchem Group Limited (8 October 2019); Completed acquisition by Vanilla Group Limited (JLA) of Washstation Limited (3 April 2018).

<sup>142</sup> See [Merger Remedies \(CMA87\)](#).

## Informing the CMA about mergers

- 6.9 Companies and their advisers are strongly encouraged to contact the CMA at an early opportunity to discuss the application of the Act to a merger situation, particularly in cases where competition concerns cannot easily be ruled out. Contact details are available on the CMA website.<sup>143</sup>
- 6.10 There are two ways in which parties to a merger that is sufficiently advanced may voluntarily bring a merger to the attention of CMA. These are:
- (a) Where merger parties wish to formally notify a merger to the CMA for investigation, they should first submit a request for a case team.<sup>144</sup> This request is made by submitting a Case Team Allocation Form (CTAF), available on the CMA website, and following up with a Merger Notice.
  - (b) Where merger parties do not intend to formally notify a merger to the CMA for investigation, they can submit a short briefing paper to the mergers intelligence function explaining why, in their view, the merger does not give rise to a relevant merger situation and/or does not give rise to an SLC. This may result in a decision to investigate, or the CMA may indicate that it has no further questions about the merger at that stage.<sup>145</sup> Further information relating to the mergers intelligence function is set out in the [Guidance on the CMA's mergers intelligence function \(CMA56revised\)](#).
- 6.11 In addition, as noted at paragraph 6.4 above, there is a requirement on undertakings designated as having strategic market status to report certain mergers to the CMA before completion.<sup>146</sup>
- 6.12 As part of pre-notification, merger parties will be asked to provide information to the CMA in relation to whether they consider the merger to fall within the scope of a public interest consideration.

### **Submitting a Merger Notice**

- 6.13 If merger parties wish to obtain a binding decision from the CMA, a formal investigation is required. This process is commenced by the submission of a CTAF, followed by a Merger Notice.<sup>147</sup> The submission of the final Merger Notice

---

<sup>143</sup> See: [Mergers: How to notify the CMA of a merger - GOV.UK \(www.gov.uk\)](#).

<sup>144</sup> See [section 96](#) of the Act.

<sup>145</sup> This does not preclude further questions at a later stage and, if further information comes to light, the CMA may open an investigation at any point until the expiry of the four-month statutory period set out in [section 24](#) of the Act.

<sup>146</sup> See [Guidance on the mergers reporting requirement for SMS firms \(CMA 195\)](#).

<sup>147</sup> The relevant templates are available at: [Merger notice forms - GOV.UK \(www.gov.uk\)](#).

is typically preceded by a pre-notification process during which the CMA ensures that it has sufficient information to be able to begin its phase 1 investigation.

### *Case Team Allocation Form*

- 6.14 The pre-notification process is available for all transactions regardless of whether or not they are in the public domain. The CMA does not make public the fact that it is in pre-notification discussions on a case. The submission of a CTAF enables the CMA to allocate a case team to lead the CMA's phase 1 investigation. The case team is the principal point of contact within the CMA for the merger parties and their representatives.
- 6.15 The pre-notification process is not available for transactions that remain hypothetical. Where the merger parties have not signed a share purchase agreement or equivalent, the CTAF should therefore set out evidence of a good faith intention to proceed with the transaction (such as because heads of terms have been concluded, adequate finance has been put in place, or the transaction has been subject to board-level consideration). In the case of a public bid, the CMA will expect at least a public announcement of a firm intention to make an offer or the announcement of a possible offer in order to open a phase 1 investigation.<sup>148</sup>
- 6.16 For completed mergers, the CMA is likely to impose an IEO and issue an information request to ascertain the extent of any integration.
- 6.17 Merger parties should keep the CMA informed of any material developments, in particular in relation to the timing or status of the transaction, following the submission of the original CTAF.

### *Pre-notification process*

- 6.18 The case team will endeavour to review submissions and revert to the merger parties within a reasonable timeframe. Where the CMA considers that a pre-notification meeting or telephone call/videoconference is desirable, the case team will schedule one. In some cases, in pre-notification the CMA may issue an invitation to comment and/or engage with relevant third parties.

---

<sup>148</sup> Corresponding with Rules 2.7 and 2.4 of the [City Code on Takeovers and Mergers](#) (the Takeover Code) respectively.

### *Benefits of pre-notification*

- 6.19 Pre-notification is the process in which the CMA ensures that it has all the information it needs before formally starting its merger inquiry. It is intended to enable information-gathering and engagement on the issues that are likely to be the focus of the CMA's formal investigation. Depending on the circumstances of the case at issue, the pre-notification process is intended to facilitate:
- (a) The clarification of the information and evidence the CMA will require for the purposes of the Merger Notice and is likely to require during the 40 working day investigation;
  - (b) The clarification of any types of information in the Merger Notice form that the CMA does not consider necessary for a complete notification in the case at hand; and
  - (c) Informal dialogue on the CMA's likely approach to the assessment of particular competition concerns (noting that the CMA's assessment of the substance of the case is ultimately arrived at by its formal investigation), including the approach to evidence-gathering to inform that assessment (including, for example, the approach to any local analysis that may be appropriate).<sup>149</sup> In particular, in some cases, the CMA may invite the merger parties to make early submissions on specific theories of harm that it is considering.
- 6.20 In some cases, pre-notification may also be an opportunity for the case team and the merger parties to discuss, on an informal basis (and without prejudice to the CMA's competition assessment),<sup>150</sup> potential remedy options if a competition

---

<sup>149</sup> This includes any primary data collection undertaken for the purposes of merger review, such as a consumer survey. The time and scale of work required to design and conduct reliable consumer surveys means that they are often more suited to use during an in-depth phase 2 process (although the CMA sometimes conducts its own surveys at phase 1). If merger parties consider that the gathering of survey evidence may allow the merger to be cleared at phase 1, the CMA encourages parties, prior to undertaking such a survey, to discuss the need for, and (as appropriate) design and scope of, the survey with the CMA during pre-notification discussions. This will increase the likelihood that the survey results will constitute robust evidence (although the final assessment of the evidence remains one for the decision maker at the end of the investigation). The CMA has published [Good practice in the design and presentation of consumer survey evidence in merger cases \(CMA78\)](#) to provide further assistance to merger parties. Given, however, that the circumstances of each case vary considerably, parties are encouraged to discuss with the CMA in advance how the principles in that document should be applied in their case.

<sup>150</sup> In this guidance, all references to 'without prejudice' or 'on a without prejudice basis' shall mean 'without prejudice to the CMA's substantive assessment of the competition issues'.



concern is ultimately found. Such discussions will not usually be disclosed to the CMA decision maker in advance of his or her decision on competition issues.<sup>151</sup>

### *Formal commencement of the investigation*

- 6.21 Once the Merger Notice is complete (which also requires the merger to be public knowledge), the CMA is able to commence its 40 working day investigation.<sup>152</sup>
- 6.22 The 40 working day period within which the CMA must decide whether the test for reference is met begins on the working day after the CMA has confirmed to the merger parties that:
- (a) it is satisfied that it has received a complete Merger Notice meeting the requirements of the Act: that is, it is in the prescribed form and contains the prescribed information, and states that the existence of the proposed merger has been made public; or
  - (b) the CMA believes that it has sufficient information to enable it to begin its investigation.
- 6.23 The template Merger Notice,<sup>153</sup> once completed to the satisfaction of the CMA, comprises the 'prescribed form' for the purposes of the Act. The template includes guidance notes to assist parties in identifying the information that is likely to be required by the CMA within the Merger Notice. In certain mergers, some of the information requested by the template Merger Notice may not be relevant (or may not be required to the full extent indicated in the guidance notes in the template Merger Notice).<sup>154</sup> Merger parties are encouraged to engage with the case team during pre-notification to discuss what information is likely to be required for a complete Merger Notice.

---

<sup>151</sup> In exceptional circumstances (eg where the remedies are likely to be complex in design and/or implementation, or where competition authorities in other jurisdictions are considering a merger which the CMA is also investigating), or when requested by the merger parties, the decision maker may be involved in discussions concerning UILs prior to taking the SLC decision. The merger parties will be informed if the decision maker deems that this is appropriate. In these circumstances, the decision maker will engage with the merger parties, in order to maximise the chance of the CMA achieving an effective remedy to any competition concerns which might arise from the merger. The merger parties are not obliged to engage with the decision maker. The CMA will consider on a case-by-case basis whether additional procedural safeguards are necessary to ensure that the early discussion of remedies does not prejudice the SLC decision: see [Merger Remedies \(CMA87\)](#), at paragraph 4.6.

<sup>152</sup> Under [section 96\(2\)\(b\)](#) of the Act, a Merger Notice must state that the existence of the proposed merger has been made public.

<sup>153</sup> Available at [Merger notice forms - GOV.UK \(www.gov.uk\)](#).

<sup>154</sup> The fact that the CMA has accepted a Merger Notice as complete without having received particular information from the merger parties does not prevent the CMA requesting that information at a later stage, should it consider it to be material to its review.

- 6.24 Merger parties are free to supply the requisite information in the format of the Merger Notice template, or to provide a submission in a written format of their choosing, accompanied by a signed and annotated version of the Merger Notice template completed to indicate clearly where in that bespoke submission the information responsive to each question in the Merger Notice can be found.
- 6.25 The CMA will endeavour to confirm that a submitted notice is complete as promptly as is practicable in the circumstances.<sup>155</sup> Similarly, where it considers that prescribed information is missing from a submitted Merger Notice, the CMA will inform the merger parties of this fact. The CMA may, in appropriate circumstances, use its compulsory information-gathering powers (described in chapter 9) to obtain the necessary information.

*Rejection of a Merger Notice after commencement of the initial period*

- 6.26 Even where the CMA has accepted a Merger Notice and confirmed that the 40 working day initial period has commenced, it can, at any time during that initial period, subsequently reject a Merger Notice for three reasons:<sup>156</sup>
- (a) it suspects information given to the CMA, whether in the Merger Notice or otherwise, to be false or misleading;
  - (b) it suspects that the relevant parties do not propose to carry the notified arrangements into effect; or
  - (c) the merger parties fail to provide information which should in fact have been included in the Merger Notice, or fail, without reasonable excuse, to provide on time, any information requested by the CMA using its powers under [section 109](#) of the Act.
- 6.27 The CMA's decision to reject a Merger Notice takes effect from the moment it is sent to the notifier or an authorised representative. The CMA will give notice in writing (including by email).

---

<sup>155</sup> This will typically be within five (and no more than ten) working days of receipt of that Merger Notice, and is likely to depend on, for example, the volume and length of submissions, the extent to which the CMA has previously considered earlier drafts of the same submissions, and the available CMA resource. In general, the CMA is likely to be able to provide such confirmation more promptly in those cases in which parties have engaged in pre-notification.

<sup>156</sup> Under [section 99\(5\)](#) of the Act.

### *Withdrawal of a Merger Notice*

- 6.28 A company can withdraw a Merger Notice at any time. The withdrawal must be made in writing by the notifier or an authorised representative.
- 6.29 Where a Merger Notice is withdrawn, but the CMA suspects that the merger parties nevertheless propose to carry the notified arrangements into effect, it will continue to examine the merger on its own initiative. In that scenario, the CMA will not be bound by its original statutory deadline to reach its decision as to whether its duty to refer applies.<sup>157</sup>

### *Reference after expiry of statutory deadlines*

- 6.30 In some circumstances, a notified merger can still be referred for a phase 2 investigation after expiry of the statutory periods in [section 34ZA](#) of the Act within which the CMA must decide whether its duty to refer a merger is met.<sup>158</sup>

## **Competing bids and parallel industry mergers**

- 6.31 Where there are competing bids for the same company, the CMA tries, other factors being equal, to consider them simultaneously. As in the case of a single bidder, each case will be considered on its own merits. It does not necessarily follow that, because one is referred, the other or others will be also.

## **Restrictions directly related and necessary to the merger (ancillary restraints)**

- 6.32 Mergers and ancillary restrictions to the merger are generally excluded from the prohibitions of the Competition Act 1998 under [Schedule 1](#) of the Competition Act 1998.

---

<sup>157</sup> [Section 100\(1\)\(f\)](#) of the Act. A fee will be payable on the publication of the CMA's decision as to whether its duty to refer applies.

<sup>158</sup> [Section 100\(1\)](#) of the Act. These are where: the Merger Notice is rejected by the CMA prior to the end of the initial 40 working day period; the Merger Notice is withdrawn; before the merger covered by the Merger Notice is completed, any of the enterprises concerned enters into an unrelated merger with any other enterprise not covered by the Merger Notice; the merger covered by the Merger Notice is not completed within six months of the expiry of the consideration period; any information supplied by the notifier (or any associate or subsidiary) is in any material respect false or misleading; any material information which is, or ought to be, known to the notifier (or an associate or subsidiary) is not disclosed to the CMA (such information must be given in writing); or the merger parties have offered UILs to the CMA (or to the Secretary of State in public interest cases) but the CMA (or Secretary of State) has not accepted those UILs.

6.33 The CMA's analytical approach to ancillary restrictions is described in Appendix C.

## 7. Fast track processes and conceding an SLC

- 7.1 In some circumstances, merger parties may wish to waive their rights in relation to certain procedural steps in order to enable a binding outcome to be arrived at more quickly.
- 7.2 As set out below, merger parties are able to request that a case should be ‘fast tracked’ to the consideration of UILs or to an in-depth phase 2 investigation.
- 7.3 Similarly, in a phase 2 investigation, merger parties are able to ‘concede’ that the relevant merger situation has resulted, or may be expected to result, in an SLC within a specified market or markets for goods or services in the UK.
- 7.4 The CMA expects that these cases will usually progress substantially more quickly than they would have done under the ordinary investigation timetable. As explained below, a request for a fast track process may not always be granted and such requests are therefore made on a ‘without prejudice’ basis. The CMA will also consider on a case-by-case basis whether additional procedural safeguards are necessary to ensure that a request for a fast track process, or to concede an SLC, does not, in the event that it is declined, prejudice the CMA’s SLC decision at phase 1 or phase 2.

### Fast track processes

- 7.5 Merger parties are able to request that a case should be ‘fast tracked’ for two purposes:
- (a) to proceed more quickly to offering UILs, with the objective of reaching a phase 1 clearance with remedies;<sup>159</sup> or
  - (b) to proceed more quickly to an in-depth phase 2 investigation.

---

<sup>159</sup> See, for example, CMA Decisions: Anticipated acquisition by Microsoft Corporation of Activision Blizzard, Inc. (excluding Activision Blizzard, Inc.’s non-EEA cloud streaming rights) (22 September 2023); Anticipated acquisition by GIC (Realty) Private Limited and Greystar Real Estate Partners, LLC of Student Roost via Roost Bidco Limited. (8 November 2022); Completed acquisition by Wm Morrison Supermarkets Ltd of certain assets of McColl’s Retail Group Plc, Martin McColl Limited, Clark Retail Limited, Dillons Stores Limited, Smile Stores Limited, Charnwait Management Limited, and Martin Retail Group Limited (8 September 2022); Completed acquisition by Riviera Bidco Limited (23 August 2022); Anticipated acquisition by Ali Holding S.r.l. of Welbilt, Inc. (9 June 2022); Anticipated acquisition by Stryker Corporation of Wright Medical Group N.V. (30 June 2020); Completed acquisition by CD&R Fund IX of MRH (GB) Limited (31 August 2018); and Completed acquisition by GTCR of PR Newswire (20 June 2016).

### ***Fast track for the consideration of UILs***

- 7.6 The merger parties can request a case to be referred for the consideration of UILs early during the phase 1 investigation or during pre-notification.
- 7.7 In this circumstance, the merging parties would typically have discussed possible UILs with the CMA case team early during the phase 1 investigation or during pre-notification.<sup>160</sup>
- 7.8 The merger parties are required to accept in writing that the test for reference is met (ie that there is sufficient evidence available to meet the CMA's statutory threshold for reference) and that they agree to waive their right to challenge that position during a phase 1 investigation. This process therefore differs from circumstances in which merging parties have hypothetical discussions with the CMA case team, on a without prejudice basis, on possible remedies in the event that the CMA decision maker decides that the merger gives rise to an SLC following the issues meeting process.<sup>161</sup>
- 7.9 The CMA will therefore not follow all of the normal procedural steps prior to reference (including an issues meeting). The CMA will generally reduce the time provided for third-party consultation, given that the merger parties have accepted that competition concerns arise, and third parties will have an opportunity to present their views on whether the proposed remedies are effective during the consultation on UILs.
- 7.10 The CMA may decline a request for a fast track process where this would not be appropriate for the substantive assessment of the case (for example because there remains material uncertainty about the nature or scope of the potential competition concerns that the merger gives rise to) or for the efficient conduct of the CMA's investigation (including, for example, where this could hinder the ability of the CMA to align its proceedings with those in other jurisdictions).
- 7.11 Any UILs offered further to a fast-track process are subject to the same requirements as UILs in other phase 1 cases, as set out in the CMA's guidance on [Merger Remedies \(CMA87\)](#). For the avoidance of doubt, this means that, even where the CMA has discussed possible UILs with the merger parties at an early stage, there remains the possibility that the transaction is referred to a phase 2 inquiry if the CMA ultimately decides that the UILs do not meet these requirements.

---

<sup>160</sup> For further information on the UIL process, see [Merger Remedies \(CMA87\)](#).

<sup>161</sup> See [Merger Remedies \(CMA87\)](#) at paragraph 4.4.

7.12 As in any other case in which the CMA has decided to investigate, the CMA is required to publish a reasoned decision at the end of a phase 1 investigation in fast track to UILs cases.<sup>162</sup>

### ***Fast track to phase 2 investigation***

7.13 The DMCC Act introduced a statutory fast track process for certain types of mergers. Under that process, the merger parties can request a case to be referred for a phase 2 investigation without having to concede an SLC finding. The statutory fast track process involves the steps explained below. The statutory process is not available for mergers of water enterprises nor mergers of energy networks.<sup>163</sup>

### ***Fast track reference request***

7.14 The merger parties can submit a fast track reference request at any time before the end of the 40 working day period for the phase 1 investigation (the initial period), including in the pre-notification period, if the conditions set out at paragraph 7.16 below are met.<sup>164</sup>

7.15 However, the CMA encourages merger parties to initiate informal discussions about a potential fast track reference request, including the suitability of the merger for such procedure, as early in proceedings as possible. The CMA also encourages merger parties to submit a fast track reference request during pre-notification or in the early stages of a phase 1 investigation. As further explained below, the CMA would be unlikely to grant any request for a fast track procedure received at a later date on the basis that it would not expect to be able to achieve the same administrative efficiencies.

7.16 The merger parties can submit a fast track reference request if the following conditions are met:<sup>165</sup>

---

<sup>162</sup> [Section 107](#) of the Act.

<sup>163</sup> In these types of mergers, if parties wish to concede the adverse impact to the ability of the relevant regulator to make comparisons, the CMA may consider whether it is appropriate to proceed by way of an administrative fast track (see CMA190 Energy Network Mergers Guidance, paragraph 3.13). In such cases, the considerations with respect to efficiency and effectiveness of review set out with respect to the operation of the statutory fast track procedure would apply to the CMA's decision as to whether to proceed with an administrative fast track. In administrative fast track cases, the CMA will follow the standard approach to publishing a reasoned decision before the reference. Neither the statutory fast track process nor the administrative fast track process applies where the Secretary of State has issued a public interest intervention notice or a special intervention notice in relation to the merger in question.

<sup>164</sup> Section 34ZD(2) of the Act (introduced by the DMCC Act).

<sup>165</sup> Section 34ZD(1) of the Act (introduced by the DMCC Act).

- (a) arrangements or proposed arrangements might have resulted or might result in the creation of a relevant merger situation (the 'arrangements concerned')
- (b) no reference has been made under section 22 or section 33 in respect of the arrangements concerned; and
- (c) the CMA has not informed the persons carrying on the enterprises concerned of a decision that the duty to make a reference under section 22(1) or section 33(1) does not apply in respect of those arrangements.

7.17 Parties are encouraged to explain in the fast track request why, in their view, there are arrangements or proposed arrangements which might have resulted or might result in the creation of a relevant merger situation. As noted above, the parties are not required to concede an SLC in a statutory fast track process.<sup>166</sup>

*CMA's decision to accept/reject a fast track request*

7.18 The CMA must accept or reject a fast track reference request (submitted before or after the start of the initial period) before the end of the initial period.<sup>167</sup> The CMA's decision to accept a fast track reference request must be made after the start of the initial period. The CMA's decision to reject a fast track reference request can be made before or after the start of the initial period.

7.19 The CMA has a broad discretion whether to accept or reject a fast track reference request.

7.20 The CMA may accept a fast track request if it believes that it is or may be the case that a relevant merger situation has been or will be created, and it is not prevented from making a reference under section 22(1) and section 33(1).<sup>168</sup> Depending on the stage at which the discussions on the fast track reference request commence, the CMA may need to conduct some evidence gathering in relation to the relevant merger situation question before making its decision. In particular, the CMA will not proceed with a fast track before it has sufficient information to proceed with its formal investigation. However, the CMA will not need to determine whether it is or may be the case that the merger has resulted, or may be expected to result, in an SLC. As such, the CMA may not need to undertake a detailed substantive assessment of the case before it accepts a fast

---

<sup>166</sup> SLC concession is required in the fast track to UILs process (see paragraph 7.8).

<sup>167</sup> Section 34ZE(3) of the Act (introduced by the DMCC Act).

<sup>168</sup> Section 34ZF(2) and (3) of the Act (introduced by the DMCC Act). The circumstances where the CMA may be prevented from making a reference are set out in sections 22(3) and 33(3) of the Act.



track reference request, and can conduct its in-depth assessment during the phase 2 investigation.

- 7.21 The CMA may decline a fast track reference request, for example, where: the CMA disagrees with the merger parties' assessment that the case is suitable to be fast-tracked;<sup>169</sup> or it would not be appropriate to fast-track the case for the efficient conduct of the CMA's investigation.<sup>170</sup> The CMA may also ask the merger parties to formally request a fast-track procedure by a given point in proceedings, noting that the CMA would be unlikely to be minded to grant any request for a fast-track procedure received at a later date on the basis that it would not expect to be able to achieve the same administrative efficiencies. In making its decision, the CMA will also have regard to whether the merger raises public interest considerations or whether a special public interest intervention notice has been issued.<sup>171</sup>
- 7.22 The CMA will notify the merging parties of its decision to accept or reject a fast track reference request.<sup>172</sup> Any decision to accept a fast track reference request (and the resulting reference) will also be published<sup>173</sup> but the CMA is not required to publish the reasons for any such decisions.<sup>174</sup>

#### *Changes to procedure resulting from a decision to accept a fast track reference request*

- 7.23 If the CMA accepts a fast track reference request, the CMA will proceed to refer the merger to a phase 2 investigation.<sup>175</sup> This means that the CMA will not follow all of the normal procedural steps prior to reference. In cases fast tracked to a phase 2 investigation, the CMA will generally reduce the time provided for third-party consultation through the phase 1 invitation to comment, given that third

---

<sup>169</sup> For example, in cases involving highly complex markets or assessments, or where there is significant uncertainty on key points (eg market definition or areas of overlap), the CMA may consider that further investigation at phase 1 would be beneficial in supporting an efficient and effective phase 2 process.

<sup>170</sup> Relevant factors in determining whether to decline a fast track request may include, for example, whether a fast-track could hinder the CMA's ability to align its proceedings with those in other jurisdictions.

<sup>171</sup> Section 34ZF(4) of the Act (introduced by the DMCC Act). The Statutory Fast Track Process only applies to references under sections 22 or 33 of the Act. Therefore, the CMA has no power to accept a Statutory Fast Track request if the Secretary of State has issued a public interest intervention notice under section 42 of the Act, or a special public interest intervention notice under section 59 of the Act.

<sup>172</sup> Section 34ZE(4) of the Act introduced by the DMCC Act.

<sup>173</sup> Section 107(1)(aaa) of the Act introduced by the DMCC Act. The CMA is not required to publish a decision to reject a fast track request.

<sup>174</sup> Section 107(6) of the Act (as amended by the DMCC Act).

<sup>175</sup> Where the CMA decides to accept a fast track reference request the duties to make references under sections 22(1) and 33(1) do not apply but the CMA has a duty to make a reference under sections 22(1A) and 33(1A) of the Act (section 34ZA(5) of the Act, introduced by the DMCC Act).

parties will have an opportunity to present their views during a phase 2 investigation.<sup>176</sup>

7.24 The CMA will notify the merger parties of its decision to refer the merger to a phase 2 investigation,<sup>177</sup> and will publish such decision.<sup>178</sup> The CMA is not required to publish the reasons for any such reference decision.<sup>179</sup>

7.25 In addition, where the CMA has accepted a fast track reference request and referred it to a phase 2 investigation, the CMA may extend the phase 2 deadline by up to 11 weeks (instead of the usual 8 weeks) for special reasons.<sup>180</sup>

#### *Procedure if a fast track reference request is rejected*

7.26 If the CMA rejects a fast track request, the CMA will follow all of the normal procedural steps prior to reaching a decision on any reference.

### **Conceding an SLC**

7.27 In a phase 2 investigation, merger parties are able to request that they formally accept that the CMA has evidence that establishes, to the required legal standard, that the relevant merger situation has resulted, or may be expected to result, in an SLC within specified market or markets for goods or services in the UK. If the CMA accepts the merger parties' request to concede the SLC, this will be made public early on in the phase 2 investigation, in the CMA's published documents on the relevant case page.<sup>181</sup>

7.28 In practice, merger parties may wish to consider this approach where it could facilitate the efficient conduct of the case. This might be, for example, where the 'concession' of an SLC would aid the alignment of the CMA's remedies process with proceedings in other jurisdictions or where it would enable the CMA and merger parties to focus their efforts during the remainder of the CMA's substantive assessment on other areas.

---

<sup>176</sup> If the CMA accepts a fast track request after having issued an invitation to comment, the invitation to comment period will not be reduced.

<sup>177</sup> Section 34ZA(1A) of the Act introduced by the DMCC Act.

<sup>178</sup> Section 107(1)(aaa) of the Act introduced by the DMCC Act.

<sup>179</sup> Section 107(6) of the Act (as amended by the DMCC Act).

<sup>180</sup> Section 39(3A) of the Act.

<sup>181</sup> See, for example, the 'issues statements' published on the anticipated acquisition by Carpenter Co. of the engineered foams business of Recticel NV/SA (on 26 August 2022); and the anticipated acquisition by Sika AG of MBCC Group (on 21 September 2022).

- 7.29 Where merger parties wish to ‘concede’ an SLC, they are required to accept in writing that an SLC arises within a specified market or markets for goods or services in the UK and that they agree to waive their right to challenge that position during a phase 2 investigation.
- 7.30 The CMA may decline a request to ‘concede’ an SLC where this would not be appropriate for the substantive assessment of the case (for example, because there remains material uncertainty about the nature or scope of the potential competition concerns that the merger gives rise to or competition concerns in different areas might be linked) or for the assessment of effective and proportionate remedies. The CMA will also consider whether ‘conceding’ an SLC would support the efficient conduct of the CMA’s investigation (including, for example, whether this could in fact hinder the ability of the CMA to align its proceedings with those in other jurisdictions).

## 8. Interactions with other proceedings

- 8.1 The CMA recognises that merger parties may be subject to other regulatory processes in addition to UK merger control, such as the City Code on Takeovers and Mergers (the Takeover Code) governing public takeovers, the national security regime put in place under the NSI Act or merger control regulation in other jurisdictions. Merger parties should inform the CMA if the merger is subject to such processes and any associated timing constraints for the merger.
- 8.2 The CMA will take account of such constraints when conducting its review and may, where the demands of the particular case and its existing caseload allow, seek to make its decision more quickly than the standard statutory timetable. If merger parties wish to request that a decision is taken more quickly than the statutory timetable, the CTAF should clearly explain why the case is urgent, with evidence if available, and why the merger parties did not commence pre-notification discussions earlier. In such cases, the CMA would expect the merger parties to be particularly alert to the importance of a full and complete Merger Notice and to the need for very prompt responses to additional requests for information.
- 8.3 In deciding whether to open an investigation on its own initiative, the CMA may take into account any merger control proceedings in other jurisdictions. The CMA may decide not to open an investigation if any remedies imposed or agreed in those proceedings would be likely to address any competition concerns that could arise in the UK. This could be the case, for example, where all of the markets that are relevant to the transaction are broader than national in scope.
- 8.4 In this circumstance, merger parties may be invited to update the CMA on the progress of proceedings in other jurisdictions and to provide the necessary confidentiality waivers for the CMA to discuss these proceedings with other competition authorities (and, where appropriate, waivers to other competition authorities to allow them to discuss the proceedings with the CMA). Merger parties may also be invited to provide confidentiality waivers in respect of other UK authorities or regulators. The CMA may also invite third parties to provide confidentiality waivers to the CMA. The CMA will typically ask the merger parties (or third parties) to provide a confidentiality waiver based on the CMA template waiver,<sup>182</sup> allowing the CMA to exchange confidential information with the relevant authorities specified in that waiver in respect of the merger. The CMA

---

<sup>182</sup> The CMA's template waiver is available at: [Confidentiality waiver template - GOV.UK \(www.gov.uk\)](https://www.gov.uk/guidance/confidentiality-waiver-template). This template should also be used in relation to waivers provided by third parties, and in relation to disclosure to other UK authorities and regulators.

template waiver may be updated from time to time to reflect the CMA's current practice. In order to aid the efficient conduct of merger proceedings, the CMA is unlikely to accept changes to the standard template waiver.

- 8.5 The CMA may consider whether to open a formal investigation at any point before expiry of the four-month statutory period and merging parties run the risk that remedies in other jurisdictions that would not fully eliminate any competition concerns relating to the UK would result in the CMA opening a formal investigation at a later stage.
- 8.6 For more information in relation to the CMA's approach to multi-jurisdictional mergers, see chapter 16 below.

## 9. The phase 1 assessment process

- 9.1 This chapter of the guidance provides a more detailed summary of certain aspects of the CMA's typical phase 1 assessment process (chapters 10 to 12 provide equivalent information on the phase 2 process). It first explains how the CMA may gather information from the merger parties and from third parties. It sets out the penalties for failure to comply with the CMA's investigatory powers. It also sets out interactions with the merger parties, as well as with other bodies. It then sets out the decision-making process followed in determining where the duty to refer is met, both in cases which do not raise material competition concerns and in more complex cases.
- 9.2 The CMA will also typically provide the merger parties with a phase 1 'opening letter' at the outset of pre-notification, setting out a brief overview of the CMA's process, in order to assist with the efficient management of the investigation.
- 9.3 The CMA aims to conduct its investigations flexibly within the applicable legal framework in light of the circumstances of the transaction under review. While the CMA will ensure that the procedural rights of merger parties and third parties are fully respected in all circumstances, it may be that certain of the steps set out below are not applied in all cases.
- 9.4 The CMA may also decide to adapt its typical phase 1 process where a transaction may be subject to merger review processes in other jurisdictions. In these cases, the CMA may coordinate certain stages of its investigation timetable with those of other competition agencies. For further information on the CMA's general approach to multi-jurisdictional mergers, see chapter 16.

### Information gathering

- 9.5 The CMA will often require additional information from the merger parties than provided in the initial Merger Notice,<sup>183</sup> or than is requested via an enquiry letter (ie where the CMA's mergers intelligence function has 'called-in' a merger), to inform its decision on reference. In practice, the CMA asks for any such additional data, information or documents as soon as it is clear this will be necessary, but, given the nature of the statutory timescales within which the CMA operates, responses will often be requested within a relatively short (but reasonable) period.

---

<sup>183</sup> This is usually the case even where the information received was sufficient for the CMA to be satisfied that the Merger Notice was complete for the purposes of commencing the CMA's review and its 40 working day timetable.

9.6 For both information requests made using the CMA's formal section 109 powers and for informal requests, it is important that recipients, as soon as possible after receiving a request for information, inform the CMA of any difficulties they may have in meeting the deadline for providing the information or in submitting the information in the requested format. Such discussions may enable the CMA to vary the information request or the stipulated response date (where appropriate).

### ***Informal requests for information***

9.7 The CMA may request information about the transaction from merger parties or third parties without using its formal powers. This may include via questionnaires, telephone or videoconference calls,<sup>184</sup> and in-person meetings.<sup>185</sup>

9.8 The intentional or reckless provision of false or misleading information in response to an informal request for information (or during discussions with the CMA) is a criminal offence.<sup>186</sup>

### ***Formal requests for information***

9.9 The CMA has the power under [section 109](#) of the Act to issue a notice requiring a person to provide information or documents, or to give evidence as a witness (a 'section 109 notice'):

(a) ***Internal documents.*** The CMA regularly asks parties to provide internal documents (ie documents that merger parties or third parties have generated internally in the ordinary course of business) to inform its investigation. When requesting internal documents from the merger parties, the CMA will use a section 109 notice as standard.<sup>187</sup> When requesting internal documents from third parties, the CMA may decide to request such documents informally in the first instance or may decide to use section 109 notices if it considers this appropriate, depending on the materiality of that evidence to its investigation, and/or if it has doubts about whether it will receive a full or timely response to an informal request. More information on

---

<sup>184</sup> Where appropriate, the CMA will record telephone/videoconference calls, having informed the counterparty before doing so. The CMA will generally not transcribe these interactions but may take a written note where practicable.

<sup>185</sup> The CMA will usually take a written note of any in-person meetings. In some cases, where appropriate, the CMA may record key in-person meetings, having informed the counterparty before doing so.

<sup>186</sup> [Section 117](#) of the Act.

<sup>187</sup> As stated in paragraph 16 of the CMA's [Guidance on requests for internal documents in merger investigations \(CMA100\)](#).

the CMA's approach to requests for internal documents in merger investigations is provided in the CMA's [Guidance on requests for internal documents in merger investigations \(CMA100\)](#).

- (b) **Other information.** The CMA regularly asks parties to provide a wide variety of views, information and data to inform its investigation. Depending on the nature of the evidence being requested, the materiality of the evidence to the investigation, and/or whether the CMA has doubts about whether it will receive a full or timely response to an informal request, the CMA may request this evidence informally or through a section 109 notice.<sup>188</sup>
- (c) **Interviews.** In some cases, the CMA may also issue a section 109 notice requiring an individual to give evidence in person (or by telephone or videoconference) in a formal interview with the CMA.<sup>189</sup> This is a more formal process than an ordinary information-gathering call with the merging parties (or third parties), and a failure to comply with such a notice can result in enforcement action under [section 110](#) of the Act.

9.10 The CMA has the power to give a notice under section 109 to a person who is located outside the UK, to require the production of documents, or the supply of information, if one of the following two conditions is satisfied:<sup>190</sup>

- (a) the person is, or was, part of, or involved with or carrying on, an enterprise which has or may have ceased, or may cease, to be a distinct enterprise in circumstances where a reference has been, or may be, made under sections 22, 33, 45, 62, 62B or 68C in relation to the enterprise (the merger parties connection condition), or
- (b) the person has a UK connection (the UK connection condition) (both conditions are explained in paragraphs 9.23 to 9.33 below).

9.11 Separate to the power to issue a section 109 notice to a person who is located outside the UK, the CMA can issue a section 109 notice to a person located in the UK to require the production of documents, or the supply of information, held outside the UK.<sup>191</sup> For example, the CMA can issue a section 109 notice to a

---

<sup>188</sup> See [section 109\(3\)](#) of the Act.

<sup>189</sup> For example, in the phase 1 inquiry concerning the anticipated acquisition by Amazon of a minority shareholding and certain rights in Deliveroo (11 December 2019) the CMA requested representatives of Amazon to provide information to the CMA by means of an interview.

<sup>190</sup> Section 109B of the Act introduced by the DMCC Act.

<sup>191</sup> Section 109B (1) and (2)(b) of the Act introduced by the DMCC Act.



UK incorporated company which holds relevant information or documents in an overseas office.

- 9.12 The failure to comply without reasonable excuse with a notice under section 109 of the Act can cause delay to the review timetable. If a relevant party<sup>192</sup> fails to comply with a section 109 notice, this permits the CMA to extend the relevant statutory timetable (including, where relevant, the four-month statutory deadline for referring completed mergers) until the party has produced the documents and/or supplied the information and the CMA has assessed whether the documents and/or information form a satisfactory response to its section 109 notice (commonly known as ‘stopping the clock’).
- 9.13 The failure to comply with a section 109 notice can also result in the imposition of a fine (as explained further below).
- 9.14 The intentional or reckless provision of false or misleading information in response to a section 109 notice can also result in a fine<sup>193</sup> and is a criminal offence<sup>194</sup> (as explained further below).

### ***Third-party submissions***

- 9.15 The CMA invites comments on any public merger situation under review from interested third parties by means of an invitation to comment notice published through the Regulatory News Service and on the inquiry case page.<sup>195</sup>
- 9.16 The CMA recognises that, in some cases, third parties may have commercial incentives to raise concerns in relation to a merger. The CMA will always scrutinise any views submitted by third parties carefully and consider the available evidence, such as internal documents prepared in the ordinary course of business, to support these views.
- 9.17 The CMA also recognises that businesses may wish to engage with certain third parties (such as their customers) in relation to transactions that they enter into and to explain their position in relation to any merger control investigations that those transactions give rise to. While the CMA broadly welcomes businesses encouraging third parties to engage with the CMA’s investigations, businesses

---

<sup>192</sup> In this context, this does not include third parties who are not connected to the merger parties.

<sup>193</sup> Section 110(1A) of the Act introduced by the DMCC Act.

<sup>194</sup> [Section 117](#) of the Act.

<sup>195</sup> In some cases, the CMA will publish the invitation to comment notice during the pre-notification period.

(and their advisers) should not seek to influence the content of third-party submissions in any way.

- 9.18 Where attempts have been made to influence the content of third-party submissions, the CMA is likely to place limited weight on these submissions. Additional evidence-gathering (to verify or supplement these third-party submissions) may delay the completion of the CMA's investigation and produce additional costs, both for the CMA and for the third-party businesses that have found themselves subject to additional information requests.<sup>196</sup>
- 9.19 Finally, the CMA also recognises that third parties may have concerns about the confidentiality of information and/or documents which are provided to the CMA.<sup>197</sup> The CMA's general approach to confidentiality is set out in chapter 17 below.

### ***Extraterritorial application of formal requests for information***

- 9.20 The CMA investigates mergers where the merger parties or relevant third parties (eg competitors and customers) have no or limited physical presence in the UK. For instance, digital firms often operate different elements of their service from different jurisdictions, serving users and customers in different countries.
- 9.21 This means that information and evidence relevant to the investigation of potentially anticompetitive mergers is often held by persons located outside the UK with no or limited physical presence in the UK. Given that the key aim of the merger regime is to tackle effects on UK competition, the CMA can formally request documents and information held by companies/individuals located outside the UK, or documents and information which are located outside the UK, in certain circumstances (see below).
- 9.22 The CMA can use these powers for the purposes of both reviewing a merger, and for the purpose of any subsequent enforcement action following a review.

### ***Documents and information held by a person located outside the UK***

- 9.23 As noted above, the CMA can issue a section 109 notice to require the production of documents or the supply of information to a person (legal or natural) who is located outside the UK if it has either a connection to one of the

---

<sup>196</sup> See for example, Copart/Hills Motors merger inquiry, [Open Letter to Copart](#) (14 July 2023).

<sup>197</sup> Where the CMA intends to rely on third-party submissions as part of the case for reference in a phase 1 investigation, it will inform the merger parties of the nature of the concerns expressed by the third-parties (but not of their identity) in sufficient detail to enable the merger parties to respond to those concerns.

merger parties (merger parties connection condition) or a UK nexus (the UK connection condition).<sup>198</sup> Each condition is explained in further detail below.

#### *Merger parties' connection condition*

9.24 The first condition allows the CMA to send section 109 notices to individuals and companies (or other body of persons corporate or unincorporate) located outside the UK<sup>199</sup> which have, or have had, a connection to one of the merger parties.

9.25 This condition will be satisfied where the person located outside the UK is or was:

(i) part of one of the enterprises ceasing to be distinct;

(ii) involved with one of the enterprises ceasing to be distinct; or

(iii) carrying on one of the enterprises ceasing to be distinct.

9.26 For instance, the CMA can send a section 109 notice to companies located outside the UK which belong to the corporate group of one of the merger parties (eg a non-UK parent or topco); to the seller of the target enterprise; to investors (eg minority shareholders); to advisers (eg financial advisers or management consultants) to one of the merger parties for the purposes of the transaction in question; or to lenders/debt financiers for the purposes of the transaction in question.

9.27 For the avoidance of doubt, the first condition does not require that the individuals or companies located outside the UK have (themselves or through others)<sup>200</sup> a physical or business presence in the UK for them to be addressees of a section 109 notice.

#### *UK connection condition*

9.28 The second condition allows the CMA to send section 109 notices to individuals and companies (or other body of persons corporate or unincorporate) located outside the UK which are not related to the merger parties but have a UK connection. This includes third parties such as competitors and customers of the merger parties.

---

<sup>198</sup> Section 109B of the Act introduced by the DMCC Act.

<sup>199</sup> Eg companies which have their registered offices, headquarters, or business activities outside the UK.

<sup>200</sup> Eg through a subsidiary.

9.29 A person has a UK connection if one of the following conditions is met:<sup>201</sup>

- (i) the person is a UK national;<sup>202</sup>
- (ii) the person is an individual who is habitually resident in the UK;
- (iii) it is a body incorporated under the law of any part of the UK; or
- (iv) it carries on business in the UK.

9.30 The 'carries on business' requirement of the UK connection test is further explained below.

#### *Carries on business in the UK*

9.31 Given the variety of business models and forms of supply and the increasing importance of digital and online markets, the CMA will interpret the 'carries on business' limb of the UK connection test having regard to the general purposes of the Act. The CMA's assessment of whether a person 'carries on business' in the UK will consider the commercial reality of the person's activities and will depend on the specific facts and circumstances of each case, the industry in question, and the nature of the activities carried on in the UK.

9.32 'Carries on business' in the UK captures a wide range of activity that affects the supply of goods or services in the UK. It does not require the person to have physical presence or a place of business in the UK.<sup>203</sup>

9.33 For example, it may be satisfied where:

- (a) a person supplies goods or services (directly<sup>204</sup> or indirectly<sup>205</sup>) in the UK;<sup>206</sup>
- (b) the goods and services supplied by a person have UK users;

---

<sup>201</sup> Section 109B(4) introduced by the DMCC Act.

<sup>202</sup> 'UK national' means an individual who is: (a) a British citizen, a British overseas territories citizen, a British National (Overseas) or a British Overseas citizen; (b) a person who under the British Nationality Act 1981 (c. 61) is a British subject; or (c) a British protected person within the meaning of that Act (see section 129(1) of the Act).

<sup>203</sup> See *Akzo Nobel N.V. v Competition Commission & Ors*, [2014] EWCA Civ 482, at paragraphs 30 to 38.

<sup>204</sup> Eg through employees based in the UK.

<sup>205</sup> Eg through a subsidiary or an agent.

<sup>206</sup> Where an overseas supplier of goods or services targets UK customers/consumers (eg through a UK website, advertising, or tailoring products/services for UK customers), the CMA would expect to find that the supplier carries on business in the UK. Where an overseas supplier carries on all its business activities (eg producing goods or services, taking orders, dispatching them to UK customers) abroad, that supplier may be found not to carry on business in the UK.

- (c) a person makes provision of intangible assets relating to a digital activity, such as the creation or provision of rights (eg IP rights), available to UK users; or
- (d) a person does not directly sell goods or services in the UK but provides a key input or component (eg software) for a good or service that is ultimately supplied in the UK.<sup>207</sup>

### ***Penalties for supplying false or misleading information***

- 9.34 There are penalties for parties (including third parties) who supply false or misleading information.
- 9.35 The CMA may impose a penalty where a person has, without reasonable excuse:<sup>208</sup>
- (a) supplied information that is false or misleading in a material respect to the CMA, the Secretary of State, or Ofcom in connection with any of their merger control functions under Part 3 of the Act, or
  - (b) supplied information that is false or misleading in a material respect to another person knowing that the information was to be used for the purpose of supplying information to the CMA, the Secretary of State, or Ofcom in connection with any of their merger control functions under Part 3 of the Act.
- 9.36 The penalty is a fixed amount determined by the CMA. The penalty cannot exceed 1% of the total value of the turnover (both in and outside the United Kingdom) of the enterprises owned or controlled by the person, or £30,000 if the person does not own or control an enterprise.<sup>209</sup>
- 9.37 In addition, it is an offence punishable by a fine or a maximum of two years imprisonment (or both) to knowingly or recklessly supply false or misleading information to the CMA, Ofcom or the Secretary of State in connection with any of their merger control functions under [Part 3](#) of the Act, or to give false or

---

<sup>207</sup> The CMA would expect to find that an overseas inputs supplier carries on business in the UK if, for instance, that supplier (i) tailors the input for UK customers; (ii) complies with UK regulatory requirements specifically required to supply products/services to UK end customers/consumers; or (iii) has been asked to take any action necessary to facilitate such supply in the UK.

<sup>208</sup> Section 110(1A) of the Act introduced by the DMCC Act.

<sup>209</sup> Sections 111(4) (as amended by the DMCC Act) and 111(4A) (introduced by the DMCC Act).

misleading information to any third party knowing that they will then supply it to the CMA, Ofcom or the Secretary of State.<sup>210</sup>

### ***Penalties for failure to comply with section 109 notices***

9.38 There are also penalties for parties (including third parties) who engage in certain actions regarding section 109 notices. The CMA may impose a fine where a person has, without a reasonable excuse:<sup>211</sup>

- (a) failed to comply with any requirement of an information request notice under [section 109](#) of the Act;<sup>212</sup>
- (b) obstructed or delayed a CMA official or other person in the exercise of their powers under [section 109\(6\)](#) of the Act to take a copy of information produced pursuant to such a notice; or
- (c) altered, suppressed or destroyed any document which the person has been required to produce by a notice under section 109.

9.39 The fines for the conduct identified at paragraph 9.38 (a) above, may be of a fixed amount, calculated by reference to a daily rate, or both. The fines for the conduct identified at paragraph 9.38 (b) and (c) above are a fixed amount. The amount of the fine is determined by the CMA. In the case of a fixed amount, the fine cannot exceed 1% of the total value of the turnover (both in and outside the UK) of the enterprises owned or controlled by the person, or £30,000 if the person does not own or control an enterprise. In the case of an amount calculated by reference to a daily rate, the fine cannot exceed 5% of the total value of the daily turnover (both in and outside the United Kingdom) of the enterprises owned or controlled by the person, or £15,000 if the person does not own or control an enterprise.<sup>213</sup>

---

<sup>210</sup> [Section 117](#) of the Act. The CMA's power to impose a fine (see paragraph 9.35) and the existence of an offence are mutually exclusive. This means that the CMA cannot impose a fine if that person has been found guilty of an offence (section 110(1C) of the Act introduced by the DMCC Act) and a person will not commit an offence if the CMA has imposed a fine on that person (section 117(2A) of the Act introduced by the DMCC Act).

<sup>211</sup> Section 110(1) of the Act (as amended by the DMCC Act).

<sup>212</sup> The CMA has imposed fines in a number of merger cases for failure to comply with the requirements of section 109 notices. See penalty notices related to CMA Decisions: Anticipated acquisition by Just Eat.co.uk Limited of Hungryhouse Holdings Limited (24 November 2017); Anticipated acquisition by AL-KO Kober Holdings Limited of Bankside Patterson Limited (21 May 2019); Completed acquisition by Rentokil Initial plc of MPCL Limited (7 August 2019); Anticipated acquisition by Sabre Holdings Corporation of Farelogix Inc. (27 September 2019); Anticipated acquisition by Amazon.com, Inc of a minority shareholding and certain rights in Roofoods Ltd (Deliveroo) (26 August 2020); and Completed acquisition by Copart, Inc. of Green Parts Specialist Holdings Ltd (Hills Motors) (10 August 2023).

<sup>213</sup> Sections 111(4) (as amended by the DMCC Act) and 111(4A) of the Act (introduced by the DMCC Act).

- 9.40 In addition, it is an offence punishable by a fine or a maximum of two years' imprisonment (or both) to intentionally alter, suppress,<sup>214</sup> or destroy any information that the CMA has required to be produced<sup>215</sup> under a section 109 notice.<sup>216</sup>
- 9.41 The CMA's power to impose a fine (see paragraph 9.38 above) and the existence of an offence (see paragraph 9.40 above) are mutually exclusive. This means that the CMA cannot impose a fine if that person has been found guilty of an offence<sup>217</sup> and a person will not commit an offence if the CMA has imposed a fine on that person.<sup>218</sup>
- 9.42 This is in addition to the CMA's powers to, for example, suspend the statutory timetables for reviewing mergers where information required under a section 109 notice is not provided by a relevant person or is found to be false or misleading.
- 9.43 Further guidance on the CMA's approach to penalties is set out in [Administrative Penalties: Statement of policy on the CMA's approach \(CMA4\)](#).

## Interactions with merger parties

- 9.44 The CMA encourages merger parties and their advisers to liaise closely with the case team during the lifetime of the case. The level of interaction required between merger parties and their advisers and the CMA's case team will depend on the individual circumstances of the case in question.
- 9.45 In all cases, the CMA will have a 'state of play' discussion with the merger parties, typically 'remotely' ie by videoconference. This will generally take place in the period between working days 15 and 20 but may occur earlier depending on the circumstances of the case. The purpose of this discussion is to inform merger parties about any competition concerns that have been raised in the CMA's investigation to date, including feedback from the CMA's market test, and whether or not the CMA is to proceed to an issues letter. The case team will provide an update on the likely timetable for the case going forward.

---

<sup>214</sup> This includes destroying the means of reproducing information recorded otherwise than in legible form (section 116A(4)(b) of the Act introduced by the DMCC Act).

<sup>215</sup> This includes the production of a legible and intelligible copy of information recorded otherwise than in legible form (section 116A(4)(a) of the Act introduced by the DMCC Act).

<sup>216</sup> Section 116A of the Act introduced by the DMCC Act.

<sup>217</sup> Section 110(1C) of the Act introduced by the DMCC Act.

<sup>218</sup> Section 116A(2) of the Act introduced by the DMCC Act.

9.46 If the CMA does intend to proceed to an issues letter, the CMA will also provide an overview of the theories of harm that the CMA proposes to include in the issues letter.

## Contacts with other bodies

9.47 The CMA may also contact other governmental bodies, regulators (including the sectoral regulators), industry associations and consumer bodies for their views on merger cases where appropriate. Sectoral regulators may also carry out their own public consultation before providing comments to the CMA. The CMA will take any views it receives into account, although it is ultimately for the CMA to decide whether there is a realistic prospect that the merger will give rise to an SLC.<sup>219</sup>

9.48 Where a merger is being investigated by competition authorities in other jurisdictions, the CMA will typically seek a confidentiality waiver from the merger parties (and may seek waivers from third parties in some cases). This is intended to facilitate the discussion of any competition concerns that may arise from the merger, the exchange of confidential information and evidence related to the merger, the discussion of any potential or actual remedies and, where appropriate, the gathering of information to facilitate coordinating certain stages of the investigation timetables between the CMA and other competition authorities. The CMA's ability to exchange confidential information and evidence with other competition authorities can be beneficial for the merging parties (and third parties) as well as for the CMA, as it can assist with international cooperation and coordination, which in turn supports the speed and efficiency of CMA merger investigations. Where confidentiality waivers are not provided, the CMA may be able to utilise other information gateways under [Part 9](#) of the Act to share information with other authorities.

9.49 Where a merger may be investigated by the CMA on competition grounds and for national security reasons under the NSI Act, the CMA may share confidential information with the Secretary of State and the Investment Security Unit (ISU), part of the Cabinet Office, and to facilitate coordination, as may be appropriate, in cases being investigated in parallel.<sup>220</sup>

---

<sup>219</sup> The operation of the public interest intervention regime in mergers is described below in chapter 14.

<sup>220</sup> In order to share confidential information with the ISU, the CMA may seek a confidentiality waiver from the merger parties and/or use the mechanism provided by [section 54\(1\)](#) of the NSI Act.



## **Media mergers**

9.50 In local media mergers involving newspaper publishing and/or commercial radio or television broadcasting, where the case raises *prima facie* competition concerns, the CMA will ask Ofcom to provide it with an assessment in order to further inform the CMA's decisions on the reference test and on the application of any available exceptions to the duty to refer. Drawing on Ofcom's understanding of media markets, this assessment may include information relating to:

- (a) the overall market context;
- (b) the relevant counterfactual to the merger (including the risk of the asset or business in question failing);
- (c) the scope of relevant product and geographic markets;
- (d) the competitive effects of the merger; and
- (e) exceptions to the duty to refer, and in particular Ofcom's views on whether the markets are of insufficient importance (*de minimis*) to warrant reference and whether there are RCBs that might be weighed against an identified SLC.

9.51 For further information on the role of Ofcom in relevant mergers where the Secretary of State has issued a Public Interest Intervention Notice (PIIN), see chapter 14 below.

## **National Health Service mergers**

9.52 The CMA no longer has jurisdiction to review mergers solely involving NHS foundation trusts, NHS trusts or a combination of both, which are now assessed by NHS England instead.<sup>221</sup> However, the CMA will continue to have jurisdiction over the merger of NHS trusts and NHS foundation trusts with other enterprises (eg a private healthcare provider) which meet the Act's jurisdictional thresholds. In instances where a CMA review may be a possibility, NHS England will work with trusts to understand and explain the requirements. Trusts should contact NHS England in situations where it is unclear whether the CMA would have jurisdiction to review the proposed transaction.<sup>222</sup> NHS England has a duty to

---

<sup>221</sup> [Section 83](#), Health and Care Act 2022.

<sup>222</sup> [NHS England, Assuring and supporting complex change Statutory transactions, including mergers and acquisitions October 2022](#), at paragraph 1.3.

share regulatory information with, and provide assistance to, the CMA where the CMA requires it to exercise its functions, including its powers in relation to merger review.<sup>223</sup>

## The phase 1 decision making process

- 9.53 This section sets out the procedure typically followed by the CMA when it is deciding whether the test for reference for a phase 2 investigation is met ('the SLC decision').
- 9.54 In cases that raise no serious competition issues, the decision to clear the merger is made by a staff member of the CMA (at the Assistant Director level or above). The decision will then be adopted by the CMA, relayed to the merger parties or their advisers and announced publicly. See chapter 17 for the process around publishing the CMA's decisions.
- 9.55 In cases that raise more complex or material competition issues, a different process is followed. As noted above, the CMA will have a 'state of play' discussion with the merger parties in which it will indicate whether or not the CMA is minded to proceed to an issues meeting. The merger parties will be invited to attend an issues meeting.<sup>224</sup>
- 9.56 An issues letter is sent to the merger parties to help them prepare for the issues meeting. The issues letter sets out the core arguments in favour of a reference in the case so that merger parties have an opportunity to make representations on these concerns during the issues meeting and in a written response to the issues letter. The issues letter is the main means the CMA uses to satisfy its duty to consult under [section 104](#) of the Act at phase 1. Issues letters will contain sufficient information for the merger parties to make informed representations on the case for reference. For reasons of practicability, including the constraints of the statutory timetable at phase 1, the CMA does not consider that it will be necessary or appropriate to disclose confidential information into a confidentiality ring during the phase 1 investigation, other than in the exceptional circumstance where that confidential information forms part of the 'gist of the case' the merger parties have to answer and cannot be summarised in a non-confidential way.<sup>225</sup>

---

<sup>223</sup> [Section 82](#), Health and Care Act 2022.

<sup>224</sup> Given the statutory deadlines for the phase 1 investigation that apply to the CMA, the CMA may be limited in its ability to accommodate requests from the merger parties for the issues meeting to be held at a time or date other than that suggested by the CMA.

<sup>225</sup> *R v Secretary of State for the Home Department, Ex parte Doody* [1993] UKHL 8, page 14 and *Meta Platforms Inc v Competition and Markets Authority* [2022] CAT 26, paragraph 157(3).

Determining this ‘gist’ is acutely context sensitive, and the CMA has a wide margin of appreciation in deciding what the gist of the case is.<sup>226</sup>

- 9.57 The issues letter is not a provisional decision or a statement of objections. Rather, the issues letter sets out hypotheses which the CMA is still evaluating in the light of the evidence put to it by the merger parties and gathered from third parties. The issues letter will therefore typically not consider in detail the arguments in favour of clearance.
- 9.58 The CMA will provide the merger parties with a short interval of two working days (at least 48 hours, not counting weekends or public holidays) between receipt of the issues letter and the issues meeting to allow them time to prepare. Although this is a relatively short time period, the description of the competition concerns provided by the case team in the state of play discussion should ensure that the merger parties understand the theories of harm that the issues letter outlines at an earlier stage and can already start to prepare their representations to the CMA on these points.<sup>227</sup>
- 9.59 Merger parties may either respond to the issues letter in writing, or orally at an issues meeting, or both.<sup>228</sup> The case team will advise the merger parties on the deadline within which responses must be received in order to be considered within the statutory time limits for the SLC decision. The period to make written submissions will typically be longer than the period of two working days (at least 48 hours, not counting weekends or public holidays) to prepare for the issues meeting.
- 9.60 Third parties will not normally be informed as to whether an issues meeting has been held (or will be held) in a particular case and will not be given a copy of the issues letter.
- 9.61 Issues meetings will generally be chaired by a member of the case team and, absent exceptional circumstances, the phase 1 decision maker (either the Senior Director of Mergers or another senior member of CMA staff) will attend.<sup>229</sup>
- 9.62 To further enhance the level of scrutiny to which the case team’s recommendations are subject, and to assist the phase 1 decision maker in

---

<sup>226</sup> *Meta Platforms Inc v Competition and Markets Authority* [2022] CAT 26, paragraph 148(4).

<sup>227</sup> However, due to the timing constraints of a phase 1 investigation, the CMA is not in a position to provide any written information in relation to these theories of harm ahead of the issues letter.

<sup>228</sup> There is no obligation to respond to an issues letter and/or to attend an issues meeting.

<sup>229</sup> If, for exceptional reasons, it is not practicable for the phase 1 decision maker to attend the issues meeting, he or she will in any event be informed of the discussion at the issues meeting by those who were present at that meeting, and will consider this alongside the other (written and oral) evidence in the case.

making the SLC decision, a member of CMA staff from outside the case team is charged specifically with acting as a 'devil's advocate' to comment critically on the case team's recommended outcome (whether that is for or against reference). The 'devil's advocate' will also attend the issues meeting wherever possible.

- 9.63 At the issues meeting, the CMA will wish to speak to senior management in the businesses affected by the merger. The CMA will inform the merger parties if it wishes specified individuals or representatives of particular business areas to attend the issues meeting. Merger parties may wish to provide a presentation for the issues meeting, particularly where they have not yet responded in writing to the issues letter.
- 9.64 In exceptional circumstances (eg where the remedies are likely to be complex in design and/or implementation or where competition authorities in other jurisdictions are considering a merger which the CMA is also investigating), or when requested by the merger parties, the decision maker may choose to be involved in discussions concerning UILs prior to taking the SLC decision. The merger parties will be informed if the decision maker deems that this is appropriate. In these circumstances, the decision maker will engage with the merger parties, in order to maximise the chance of the CMA achieving an effective remedy to any competition concerns which might arise from the merger. The merger parties are not obliged to engage with the decision maker. The CMA will consider on a case-by-case basis whether additional procedural safeguards are necessary to ensure that the early discussion of remedies does not prejudice the SLC decision.<sup>230</sup>
- 9.65 After the issues meeting, the phase 1 decision maker will meet with members of the case team and the devil's advocate to consider the case and to decide on whether or not the reference test is met.
- 9.66 In cases where the decision maker concludes that the test for reference is met, the decision maker will then consider whether any of the available exceptions to the duty to refer (such as the 'de minimis' exception) should be applied.<sup>231</sup>
- 9.67 Once the decision maker has considered whether any of these exceptions apply, the decision will be adopted by the CMA, relayed to the merger parties or their advisers and announced publicly. See chapter 17 for the process around publishing the CMA's decisions.

---

<sup>230</sup> [Merger Remedies \(CMA87\)](#), paragraph 4.6.

<sup>231</sup> See [Mergers: Exceptions to the duty to refer \(CMA64\)](#).

## **Phase 1 remedies process – undertakings in lieu of reference (UILs)**

- 9.68 If the CMA finds that its duty to refer the merger for a phase 2 investigation applies, the merger parties may have an opportunity to avoid that outcome by offering binding undertakings in lieu of reference (UILs) for the CMA (or the Secretary of State in public interest cases)<sup>232</sup> to accept.
- 9.69 UILs may be accepted by the CMA only where it has concluded that the merger should be referred for a phase 2 investigation. Any UILs accepted by the CMA must be for the purpose of remedying, mitigating or preventing the SLC concerned or any adverse effects identified.
- 9.70 For further information on the CMA’s approach to remedies, please see [Merger remedies \(CMA87\)](#).

### ***Procedure for submission of UILs***

#### *UILs proposals in advance of the SLC decision*

- 9.71 Merger parties can put forward possible UILs to the CMA case team at any stage during the phase 1 investigation or during pre-notification.<sup>233</sup> The CMA strongly recommends that merger parties and their legal advisers consider possible UILs early in the process, even if this is not communicated to the CMA. This ensures that, if an SLC decision is reached, the merger parties will be better able to submit their proposed UILs and engage in any related discussions with the CMA rapidly, maximising the chance of the CMA accepting UILs as an alternative to reference.
- 9.72 In advance of the SLC decision, the CMA case team will assist merger parties in understanding the function of UILs. They will also, where possible, provide guidance to merger parties on which of the possible remedies being considered by the merger parties might be suitable. However, these discussions will be conducted on a hypothetical basis, as the case team will not be able to inform the merger parties of the CMA’s decision or direction of thinking on whether there is a realistic prospect that the merger gives rise to an SLC prior to the announcement of the decision. Any discussion of UILs prior to the SLC decision will not prejudice that decision.

---

<sup>232</sup> See chapter 14.

<sup>233</sup> Such discussions with the case team will not impact on the prospect that the decision maker ultimately determines that the test for reference is not met; nor will they prejudice the merger parties’ right to decide not to offer any UILs.

- 9.73 The decision on the existence and scope of the SLC precedes and is independent of the decision on whether any UILs offered address the competition concerns identified. If a phase 1 investigation case proceeds to an issues meeting, the merger parties will be invited to raise possible UILs with the case team at the end of the meeting after the decision maker has left the room.<sup>234</sup>
- 9.74 The decision maker will not typically be involved in any discussions concerning UILs until the decision on the existence and scope of SLC(s) has been made. In exceptional circumstances or when requested by the merger parties, the decision maker may choose to be involved in discussions concerning UILs prior to taking the SLC decision.

#### *UILs offers following the SLC decision*

- 9.75 Merger parties may wish to see the SLC decision before discussing UILs with the CMA. The SLC decision will set out the CMA's competition concerns and should therefore provide the merger parties with sufficient information to assess whether they wish to offer UILs to provide a clear-cut remedy to those concerns.
- 9.76 Under the Act, notifying parties have up to five working days after receiving the CMA's reasons for its SLC decision to offer UILs formally in writing (the UILs offer).<sup>235</sup> During this period of time, the CMA case team will be available to discuss possible UILs with the merger parties (subject to the constraints described in paragraph 9.72). Although the merger parties will not have access to the decision maker, the case team will have, in advance of any discussions, an understanding of the decision maker's view on what might be an acceptable UILs offer.
- 9.77 Given that the period for making a UILs offer is short, merger parties should not expect to engage in iterative discussions or negotiations with the CMA. Merger parties may formally submit two or three versions of their UILs offer,<sup>236</sup> if necessary, which the CMA will consider at the same time to select the least intrusive effective clear-cut remedy, but merger parties should be careful to include the offer they believe will address fully the competition concerns set out

---

<sup>234</sup> The phase 1 decision maker will not be informed of whether any UILs were discussed until after the decision on the SLC has been made.

<sup>235</sup> [Section 73A\(1\)](#) of the Act.

<sup>236</sup> Merger parties should submit their best offer. However, on occasion, there can be uncertainty about what exactly needs to be included for the remedy to be fully effective in addressing the competition concerns identified. To avoid the unnecessary rejection of a UIL offer, the CMA is willing to consider two or three versions of an offer (eg including a smaller or larger package of assets).

in the SLC decision.<sup>237</sup> Merger parties should also indicate clearly their preferred remedy, providing reasons.

- 9.78 The Act does not allow the CMA to consider new UILs offers made after the five working day deadline for the UILs offer.<sup>238</sup>
- 9.79 If merger parties do not wish to submit a UILs offer, they may wish to inform the CMA (in writing) before the end of the five working day period so that it can proceed to make the reference to phase 2.

### *Phase 1 Remedies Form*

- 9.80 UILs offers (accompanied by the merger parties' proposed draft text of their UILs) should be made formally in writing using the CMA's Remedies Form for Offers of Undertakings in Lieu of Reference (the Phase 1 Remedies Form) and the CMA's UILs template.<sup>239</sup>
- 9.81 The Phase 1 Remedies Form provides details of the information that will assist the CMA in understanding clearly what the merger parties are offering (or not offering) in their UILs offer. Merger parties should bear in mind the following points when completing the Phase 1 Remedies Form:
- (a) A UILs offer merely to 'remedy the SLC', without specifying how this will be achieved, will be considered insufficiently clear-cut.
  - (b) A UILs offer which proposes a behavioural remedy rather than a structural remedy is generally less likely to be considered sufficiently clear-cut.
  - (c) A UILs offer to remedy the SLC through divestment of one of the overlapping businesses should make it clear which of the overlapping businesses the merger parties are proposing to divest. Where the merger parties are equally willing to divest either business, they should state this in their UILs offer. Merger parties should be aware that, in certain cases, the CMA may consider that divestment of one particular business may not be sufficient to remove the competition concerns, given the need for the divestment to be a viable business and to be capable of attracting a suitable purchaser. In this

---

<sup>237</sup> See the CMA's investigation into the anticipated acquisition by John Wood Group plc of Amec Foster Wheeler plc (2017), where the CMA did not take up the option of an upfront buyer, as it did not consider that this was necessary.

<sup>238</sup> [Section 73A\(1\)](#) of the Act.

<sup>239</sup> See [CMA's Remedies Form for Offers of Undertakings in Lieu of Reference \(Phase 1 Remedies Form\) and the CMA's UIL template](#).

situation, a UILs offer might include a fall-back proposal to divest another business should a buyer not be found quickly for the first business.

(d) Where merger parties are offering a divestiture remedy, they should state in their UILs offer whether they are proposing an upfront buyer.<sup>240</sup>

9.82 The level of information required by the CMA will vary according to the type and structure of the remedy proposed. Merger parties are encouraged to discuss with the case team the likely requirements of the CMA before completing the Phase 1 Remedies Form.

9.83 Merger parties are not obliged to complete all aspects of the Phase 1 Remedies Form, but providing all relevant information will enhance the CMA's ability to assess effectively the UILs offer.

#### *The UILs 'acceptable in principle' decision*

9.84 Where merger parties offer UILs, the CMA has until the tenth working day after the merger parties received the reasons for its SLC decision to decide whether the UILs offer (or a modified version of it) might be acceptable as a suitable remedy to the SLC or the identified adverse effects arising from it.<sup>241</sup> This decision is taken by the phase 1 decision maker.

9.85 Where the CMA decides that the UILs offer (or a modified version of it) might be acceptable as a suitable remedy, it will confirm this to the parties who offered the UILs, and issue a public announcement to that effect (the UILs 'acceptable in principle' decision).

#### *CMA discretion to propose modifications to UILs offers*

9.86 As the merger parties will have received the CMA's reasons for its SLC decision before submitting their UILs offer, the CMA expects that, in the vast majority of cases, the merger parties will be in a position to assess whether to make a UILs offer capable of providing a clear-cut remedy to the SLC within the five working day deadline. However, the CMA is mindful of the significant public policy benefits achieved through the UILs process. Therefore, the CMA reserves the right, where appropriate, to revert to the merger parties following receipt of their

---

<sup>240</sup> This is a commitment to find a buyer which will be assessed and approved by the CMA, and to conclude an agreement with this buyer, prior to the CMA's final acceptance of UILs. Merger parties are able to offer two or three versions of their UILs offer, so they might, as their preference, submit a divestiture proposal with a non-upfront buyer offer, but say that, in the alternative, they would also be willing to offer a divestiture proposal with an upfront buyer.

<sup>241</sup> [Section 73A\(2\)](#) of the Act.



UILs offer to inform them that it could be suitable to address the SLC identified, subject to specified modifications.<sup>242</sup> This can happen either before or after the UILs 'acceptance in principle' decision. These modifications will not amount to a different remedy, but minor modifications of the existing proposal.

- 9.87 Where the CMA proposes modifications to a UILs offer, it will ask the merger parties whether they agree to the proposed modifications. The merger parties will be given a short period<sup>243</sup> in which to state whether or not they wish to offer the modified UILs. This includes the opportunity to make written or oral representations if they do not agree to the proposed modifications (in full or part).

### ***Procedure for acceptance of UILs***

- 9.88 Having made the decision that the UILs offer (or a modified version of it) might be acceptable in principle as a suitable remedy, the CMA will then start the process of detailed consideration of the proposed UILs. This process also has statutory timeframes. Where the UILs involve a divestment remedy, the process will differ depending on whether or not the UILs offer includes an upfront buyer.

### ***Timeframes***

- 9.89 The CMA is required to decide whether to accept the offered UILs within 50 working days of the SLC decision.<sup>244</sup> This can be extended by up to 40 working days if the CMA considers that there are special reasons for doing so.<sup>245</sup>
- 9.90 In considering whether an extension for special reasons may be appropriate, the CMA will have regard to:
- (a) whether any delay may increase the risk of anticompetitive outcomes from the merger (eg where there is a risk that the target business may deteriorate

---

<sup>242</sup> Such modifications relate to the substance of the UIL offer, such as the specification of the divestment package or the requirement for an upfront buyer, and not to the text of the undertakings.

<sup>243</sup> The length of this period will depend on the particular circumstances of the investigation, but would not typically be longer than a few days.

<sup>244</sup> [Section 73A\(3\)](#) of the Act.

<sup>245</sup> [Section 73A\(4\)](#) of the Act. The CMA may also extend the period for considering UILs if it considers that a relevant person has failed to comply with a notice requiring evidence issued under [section 109](#) of the Act.

pending the outcome of the merger investigation, or where any consumer harm may be ongoing);<sup>246</sup>

- (b) the ability of the CMA and the merger parties to conclude the UILs acceptance process within the 50 working days; and
- (c) the likelihood that the CMA will be able to accept UILs from the merger parties if an extension is granted.

9.91 As UILs must be a clear-cut solution to the SLC identified, the CMA would not expect to have to extend the timeframe for final acceptance of UILs unless:

- (a) the case involves an 'upfront buyer' (see paragraphs 9.98 to 9.102 below);
- (b) it is necessary for the CMA to undertake a further consultation with interested third parties on a modified version of the UILs offer (see paragraph 9.96 below); or
- (c) there is some other exceptional circumstance and the additional time will likely lead to the acceptance of UILs.<sup>247</sup>

9.92 Within the SLC decision, the CMA will, where necessary, extend its four-month statutory timetable for considering a completed merger.<sup>248</sup> This period will end at the earliest of the following events:

- (a) the final giving of the UILs;
- (b) the expiry of a period of 10 working days beginning with the first day after the receipt by the CMA of a notice from the notifying party that it does not intend to give UILs; or
- (c) the cancellation by the CMA of the extension.

---

<sup>246</sup> The CMA's assessment of this issue may be linked to the likelihood of it being able to agree acceptable UILs with the merger parties if an extension is granted. Where the CMA considers that there is sufficient likelihood of reaching agreement, it would be more likely to grant an extension, in order to avoid the delay associated with an in-depth phase 2 investigation.

<sup>247</sup> In relation to (a) and (b), see the CMA's investigation into the anticipated acquisition by Muller UK & Ireland Group LLP of the dairy operations of Dairy Crest Group plc (2015). In relation to (c), see the CMA's investigation into the completed acquisition by AMC (UK) Acquisition Limited of Odeon and UCI Cinemas Holdings Limited (2017), where the CMA extended the period to ensure that the merger parties could obtain a required consent from a third party.

<sup>248</sup> [Section 25\(4\)](#) of the Act.

- 9.93 Throughout the process, the CMA remains under a statutory duty to have regard to the need to make a decision as soon as reasonably practicable.<sup>249</sup> It will therefore aim to accept the final form of the UILs as quickly as possible. In all cases, a reference may still be made if the CMA is unable to accept UILs within the statutory deadlines under the Act.
- 9.94 The CMA will agree with the merger parties a timetable of milestones through the UILs process to ensure that the merger parties are making timely progress towards the ultimate signing of an agreement with a suitable purchaser. This timetable will not be made public. However, failure by the merger parties to progress according to the timetable will be taken into account should the CMA need to consider whether to extend the 50 working day timetable for accepting UILs.

### *Consultation*

- 9.95 In order to give interested third parties an opportunity to comment, the Act provides for third parties to be consulted prior to the CMA's final acceptance of UILs.<sup>250</sup> The CMA will publish the draft of the provisionally agreed UILs<sup>251</sup> and will invite comments from third parties. The CMA is required by the Act<sup>252</sup> to give third parties a period of not less than 15 calendar days in which to respond with comments on the purpose and effect of the proposed UILs.
- 9.96 To the extent that, as a result of the consultation process or otherwise, the originally published UILs are modified, a second consultation period will be required unless such modifications are not material in any respect. In such cases, in accordance with the Act, the consultation period for third parties to respond will be no less than seven calendar days.<sup>253</sup>

### *Acceptance*

- 9.97 Following the necessary consultations, the CMA will ask the merger parties to sign the final version of the UILs, after which they will be formally accepted by the CMA. The CMA will announce publicly that it has formally accepted the UILs,

---

<sup>249</sup> [Section 103](#) of the Act.

<sup>250</sup> [Section 90](#) of, and [Schedule 10](#) to, the Act.

<sup>251</sup> The CMA may also publish non-confidential parts of the merger parties' Phase 1 Remedies Form alongside the draft UILs.

<sup>252</sup> Paragraph 2(2) of [schedule 10](#) to the Act.

<sup>253</sup> Pursuant to paragraph 2(5) of [schedule 10](#) to the Act.

thereby ending its duty to refer, and will publish the final version of the accepted UILs on the case page.

### *Upfront buyer cases*

- 9.98 Where the CMA decides that UILs will be accepted only where the merger parties have identified an upfront buyer, the CMA will not accept the UILs unless a sale agreement, generally conditional from the buyer's perspective only on acceptance of the UILs by the CMA (and the completion of the main transaction if it remains anticipated), has been agreed with a buyer for the divestment business and the CMA considers that the buyer would be acceptable.
- 9.99 Where merger parties wish to offer an upfront buyer in their UILs offer, they may either identify a proposed buyer straight away or make the offer on the basis that any divestiture would be to an upfront buyer. In the latter case, merger parties will be given a relatively short period<sup>254</sup> after the CMA's UIL 'acceptance in principle' decision in which to identify the upfront buyer. After the merger parties have proposed their upfront buyer, the CMA will assess the suitability of the proposed buyer. The CMA will gain information from the buyer and, in most cases, will meet with the buyer. The CMA will specify the proposed buyer in the public consultation.<sup>255</sup>
- 9.100 Once the merger parties have obtained provisional confirmation from the CMA that the buyer is likely to be acceptable, they will enter into a sale agreement on the terms set out in paragraph 9.98 above.
- 9.101 If, following the CMA's assessment and public consultation, the CMA considers that the proposed buyer is not suitable, the merger may either be referred to phase 2 or the merger parties will be required to identify quickly a suitable alternative buyer. In either case, the principles set out in paragraph 9.96 in relation to further public consultation will apply.
- 9.102 Given the statutory deadline by which UILs must be finally accepted, merger parties are advised to give early consideration to the possible need for, and identity of, an upfront buyer.

---

<sup>254</sup> The length of this period will depend on the particular circumstances of the investigation, but would not typically be longer than a few days.

<sup>255</sup> The CMA will consult on both the draft of the provisionally agreed UILs and the proposed buyer.

### *Following final acceptance of UILs in non-upfront buyer cases*

- 9.103 Where no upfront buyer provision is required, the CMA will continue to have an active role to play after it has formally accepted the UILs from the merger parties.
- 9.104 Where the UILs are structural in nature, they will provide for a divestment period within which the merger parties must identify a suitable purchaser for the divestment business and conclude a sale agreement with that buyer. As for an upfront buyer case, the CMA will assess the suitability of the proposed purchaser.
- 9.105 The CMA will again agree with the merger parties a timetable of milestones for this period (see paragraph 9.94).
- 9.106 Once a purchaser has been formally approved by the CMA, the merger parties are able to proceed with the divestment. Depending on the terms of the UILs, the merger parties may be required to enter into the relevant contractual document for the divestment and/or to complete the divestment by a date specified in the UILs.

### *Assessing the suitability of a purchaser*

- 9.107 In a divestiture remedy, the merger parties must satisfy the CMA that their proposed purchaser is independent of the merger parties; has the necessary capability to compete; is committed to competing in the relevant market(s); and that a divestiture to this purchaser will not create further competition or regulatory concerns. Please refer to chapter 5 of [Merger remedies \(CMA87\)](#) for more information on the CMA's purchaser suitability criteria.
- 9.108 In assessing whether a proposed purchaser should be approved, the CMA will examine information presented by the merger parties carefully and impartially, but will only undertake a proportionate amount of investigation and analysis at this phase.<sup>256</sup> If approval of a proposed purchaser requires a detailed investigation, it is likely that the CMA will choose not to approve that purchaser rather than to undertake an in-depth analysis.<sup>257</sup>
- 9.109 In principle, divestitures as a result of UILs may result in the creation of a new relevant merger situation, which the CMA could investigate. However, in practice, where a proposed divestment to a purchaser raises competition

---

<sup>256</sup> This is consistent with the requirement that UILs should provide a clear-cut solution to the SLC identified at phase 1.

<sup>257</sup> See *Co-operative Group (CWS) Limited v Office of Fair Trading* [2007] CAT 24.

concerns,<sup>258</sup> the CMA will notify the merger parties that the proposed purchaser does not satisfy the purchaser suitability criteria.

### *Monitoring trustee*

- 9.110 The CMA will assess on a case-by-case basis whether a monitoring trustee should be appointed to oversee and report on the divestiture process.<sup>259</sup> The CMA may appoint a monitoring trustee at phase 1 or phase 2.
- 9.111 Monitoring trustees help ensure the CMA better understands the progress being made in a divestiture by reporting on the merger parties' compliance with the agreed timetable. A monitoring trustee can also be used to review the separation of a business and ensure the divestiture package is as described in the proposed UILs.
- 9.112 The need for a monitoring trustee will depend, among other things, upon the nature of the divestiture package and the risk profile of the remedy. The need for a monitoring trustee in an upfront buyer case is likely to be lower than in a non-upfront buyer case, as the incentives for the merger parties to complete the divestment in good time is likely to be greater. A monitoring trustee is more likely to be appointed where:
- (a) the divestiture package is not an existing business;
  - (b) significant assets are to be excluded from the existing business;
  - (c) significant transitional arrangements are required; and/or
  - (d) purchaser risks are particularly high.
- 9.113 If merger parties consider that a monitoring trustee is not required, they should include reasons for this in their Phase 1 Remedies Form.
- 9.114 Please see chapter 8 of [Merger remedies \(CMA87\)](#) for more information on trustees and third-party monitors.

---

<sup>258</sup> The fact that the acquisition by a proposed purchaser would qualify for investigation pursuant to the share of supply test does not necessarily mean that it would create substantive competition concerns; this will depend on the circumstances of the case and the market(s) in question.

<sup>259</sup> The merger parties will be responsible for the remuneration of the monitoring trustee. To ensure that the structure of such remuneration does not compromise the monitoring trustee's independence and provides sufficient incentive to perform the required function to an appropriate standard, the CMA must approve the remuneration agreement with the monitoring trustee.

### *Divestiture trustee and CMA intervention*

- 9.115 In a non-upfront buyer case, if merger parties are unable to find a suitable purchaser capable of being approved by the CMA within the time period specified within the UILs, the UILs will typically provide for the CMA to be able to appoint a divestiture trustee to sell the divestment business on behalf of the merger parties at no minimum price, or for the CMA to direct the merger parties to sell at no minimum price.
- 9.116 Whether UILs are structural or behavioural in nature, if, after accepting the UILs, it becomes apparent to the CMA that the undertakings are not being or will not be fulfilled, the Act gives the CMA the power to issue an order against the merger parties to ensure fulfilment of the UILs.<sup>260</sup> Such orders are enforced in the High Court.

### ***Ongoing role for the CMA in behavioural UILs***

- 9.117 For behavioural UILs, the CMA has an ongoing monitoring role for the duration of the UILs.<sup>261,262</sup>

### ***UILs in public interest cases***

- 9.118 In public interest cases, which fall to the Secretary of State for decision, the CMA considers at phase 1 whether the competition issues that arise are such that the CMA would recommend a reference if there were no public interest issues. If the CMA would recommend a reference, the CMA will consider whether or not these concerns could be resolved by UILs and will advise the Secretary of State accordingly.<sup>263</sup> To the extent that merger parties make it clear that they are not prepared to offer UILs, the CMA is likely to advise that it would not be appropriate to deal with the competition concerns arising from the merger situation by way of undertakings under paragraph 3 of [Schedule 7](#) to the Act (or in the equivalent provisions in the Protection of Legitimate Interests Order).<sup>264</sup>
- 9.119 The Secretary of State must have regard to the CMA's view on competition issues but may decide that public interest issues require a different outcome to

---

<sup>260</sup> [Section 75](#) of the Act.

<sup>261</sup> [Section 92](#) of the Act.

<sup>262</sup> Note, however, that behavioural undertakings will not generally (absent particular facts) be considered to be a credible, clear-cut remedy suitable for UILs at phase 1.

<sup>263</sup> [Section 44\(4\)\(f\)](#) of the Act.

<sup>264</sup> See the anticipated acquisition by Lloyds TSB plc of HBOS plc, Report to the Secretary of State for Business Enterprise and Regulatory Reform (24 October 2008), paragraph 381.

that which would be required to address the competition issues. This could include a decision to clear the merger, a decision to make a reference, or a decision to accept undertakings, which might be different from those proposed by the CMA to resolve any competition concerns. See chapter 14 for further information on public interest mergers.

### ***Remedies for breach of UILs***

- 9.120 Once UILs have been accepted, the CMA is released from its duty to refer by [section 74\(1\)](#) of the Act. UILs therefore become the definitive solution to any SLC. [Section 74\(1\)](#) of the Act precludes a reference to phase 2<sup>265</sup> even where UILs are not fulfilled. In that situation, the CMA must rely on its order-making power under [section 75](#) of the Act and, if necessary, invoke civil proceedings, under [section 94](#) of the Act, to enforce the UILs and/or the order.
- 9.121 Under [section 94](#) of the Act, third parties have the right to bring an action for breach of statutory duty against a party to UILs where the third party has suffered loss or damage as a result of a failure to comply with the UILs. It is in part for this reason that it is important that the terms of UILs are clear and straightforward to assist with their enforceability.<sup>266</sup>

---

<sup>265</sup> Unless material facts about the relevant arrangements or transactions in consequence of which the enterprises subject to the merger have or will cease to be distinct (or relevant proposed arrangements or transactions) were not notified to the CMA, or made public before the UILs were accepted (sections [74\(2\)](#) to [\(4\)](#) of the Act).

<sup>266</sup> See [Administrative penalties: Statement of Policy on the CMA's approach \(CMA4\)](#) for further information.



## 10. The phase 2 process: overview

10.1 The following chapters set out the typical phase 2 process. This chapter sets out the role and responsibilities of the Inquiry Group and CMA case team; it also summarises, at a high-level, the phase 2 process. Chapters 11 and 12 then provide greater detail on various aspects of the process.

### The phase 2 Inquiry Group and case team

- 10.2 An Inquiry Group is appointed for each inquiry, supported by a case team of CMA staff. The duties and powers of Inquiry Groups conducting a phase 2 inquiry are set out in the Act.<sup>267</sup>
- 10.3 The Chair of the CMA is responsible for identifying and appointing the Inquiry Group that will conduct a particular inquiry and for selecting one of them to act as chair of the Inquiry Group (the Inquiry Group Chair). In practice, the Chair of the CMA will delegate these responsibilities to the CMA Panel Chair (or one of the CMA Deputy Panel Chairs).<sup>268</sup> Until the Inquiry Group is appointed, the Chair of the CMA (or his/her delegate, in practice usually the CMA Panel Chair) may act in its place.<sup>269</sup>
- 10.4 The CMA's panel members come from a variety of backgrounds and expertise in different areas including law, economics, business and consumer policy. For a phase 2 inquiry, an Inquiry Group will comprise at least three members, including the Inquiry Group Chair.
- 10.5 Before appointing a member to an Inquiry Group, the CMA will assess (by reference to the CMA's conflicts of interest policy<sup>270</sup>) whether the proposed member has any outside interests that could give rise to a conflict of interest which would affect, or be seen to affect, the Inquiry Group's impartiality (a potential conflict of interest). The CMA's practice is not to appoint a member to an Inquiry Group where a conflict of interest is likely to arise. In limited cases, the CMA may contact the merger parties to disclose an outside interest ahead of appointing a member even though the CMA believes that the potential conflict of interest would not affect, nor be seen to affect, the Inquiry Group's impartiality. Where appropriate, particular interests may also be disclosed on the relevant case page.

---

<sup>267</sup> See Parts 3 and 9 of, and Schedules 8 and 10 to, the Act and [Schedule 4](#) to the ERR13.

<sup>268</sup> The CMA Panel Chair is a member of the CMA Board.

<sup>269</sup> Paragraph 46, [Schedule 4](#) to the ERR13.

<sup>270</sup> [CMA Board: Rules of Procedure](#).

- 10.6 Inquiry Groups are appointed for the duration of the phase 2 inquiry, up to the point at which the reference is finally determined.<sup>271</sup> In cases where a merger is found to give rise to an SLC, the merger is finally determined when remedy undertakings<sup>272</sup> are accepted by the CMA or a final remedy order is made; and if no SLC is found, the reference is finally determined when the final report is published.<sup>273</sup>
- 10.7 The appointed Inquiry Group are the decision makers on phase 2 inquiries. Their role is to set the overall direction of the inquiry, review the appropriate evidence and analysis, and answer the statutory questions on the case (see chapter 3). Inquiry Groups are required by law to act independently of the CMA Board,<sup>274</sup> and therefore make their own independent decisions, based on the objective evidence before them. The appointment of an independent group is intended to provide a ‘fresh pair of eyes’ in relation to the CMA’s phase 1 investigation, in which a senior member of CMA staff decides whether the test for reference is met.
- 10.8 In order to make decisions on the statutory questions, the Inquiry Group has access to all of the relevant evidence gathered by the CMA (including any evidence gathered during the phase 1 investigation).
- 10.9 Inquiry Groups are supported by a case team. The phase 2 case team will include a combination of project delivery staff, lawyers, economists, business and financial advisers, and as appropriate, statisticians and/or data specialists.
- 10.10 For more information on panel members and Inquiry Groups, see the CMA website ([‘Our governance - Competition and Markets Authority - GOV.UK \(www.gov.uk\)’](https://www.gov.uk)) and *CMA rules of procedure for merger, market and special reference groups (CMA17)*.

## The key stages of a phase 2 inquiry

- 10.11 The key stages of a typical phase 2 inquiry are shown in the table on the following pages. This indicates the steps the CMA will usually take and what the merger parties and third parties will usually need to do at each key stage of a phase 2 inquiry. Although indicative timings for each stage have been set out, the steps described may not, in practice, always take place or may not take

---

<sup>271</sup> Sections 79(1) and (2) of the Act.

<sup>272</sup> Section 82 of the Act.

<sup>273</sup> Section 84 of the Act.

<sup>274</sup> See paragraph 49, Schedule 4 to the ERR13.

place sequentially and may sometimes overlap. In particular, information-gathering takes place throughout the inquiry.

10.12 Further, subject to agreement with the CMA, it may be possible to omit certain stages of the process where to do so would lead to greater efficiency.<sup>275</sup> There may also be reason to adjust the typical process where the merger may be subject to review in other jurisdictions (see further, chapter 16 below). In all cases, merger parties and their advisers are encouraged to speak to the CMA to discuss issues relating to process and timing.

---

<sup>275</sup> For example, merger parties may decide that certain stages of the CMA's process are unnecessary where the CMA's current view is such that the merger may not be expected to result in an SLC. See, for example, CMA Decision: Completed acquisition by Bottomline Technologies (de), Inc. of Experian Limited's Experian Payments Gateway business and related assets (17 March 2020). Merger parties are also able to concede any SLC(s) in order to more efficiently focus on remedies discussions, for example in order to better align with proceedings in other jurisdictions (see, for example, CMA Decision: Anticipated acquisition by Carpenter Co. of the engineered foams business of Recticel NV/SA (16 November 2022); and CMA Decision: Anticipated acquisition by Sika AG of MBCC Group (on 15 December 2022)) (see chapter 7 for further discussion).

**Table 2: The key stages of a typical phase 2 inquiry**

	MILESTONES	CMA	PARTIES AND THIRD PARTIES
<b>FOLLOWING REFERRAL: Possible suspension of reference (anticipated mergers only)</b>			
Following reference to phase 2	Possible abandonment of transaction	<p>CMA considers, in response to any request by merger parties, whether transaction may be abandoned and whether to suspend the phase 2 investigation for up to three weeks.</p> <p>If transaction is abandoned, CMA cancels reference.</p> <p>CMA publishes notice of suspension (and termination of any suspension if merger is not abandoned).</p>	Merger parties may request suspension of reference in light of any possible abandonment of transaction.
<b>STAGE 1: Commencement of phase 2</b>		<b>Weeks 1–6<sup>276</sup></b>	
	Reference	<p>CMA issues phase 2 opening letter to merger parties.</p>	<p>Where appropriate, merger parties and advisers attend introductory meetings (ie case management meeting and data meeting(s)) with CMA case team (which will usually be by videoconference).</p> <p>Merger parties may wish to start engagement on remedies (for example, by submitting a draft 'Phase 2 Remedies Form') on a without prejudice basis.</p>
		<p>CMA considers need for modified interim measures. If there is no phase 1 IEO in place or if there is a need for modifying the phase 1 IEO, the CMA can make an interim order or accept interim undertakings from merger parties. CMA may also consider unwinding integration (if necessary).</p>	<p>Merger parties discuss with the CMA any ongoing phase 1 IEO or, if necessary, phase 2 interim measures and reporting on compliance.</p>

<sup>276</sup> Information gathering continues to some extent throughout the inquiry. However, this initial phase (around weeks 1 to 6) is the period during which merger parties and third parties should expect information gathering to be most intensive (although the precise extent of necessary information gathering during this period will vary from case to case, depending on the extent, and ongoing relevance to the CMA's investigation, of information previously gathered at phase 1).

	MILESTONES	CMA	PARTIES AND THIRD PARTIES
		CMA publishes administrative timetable after it is shared with the merger parties.	Merger parties invited to comment on administrative timetable. CMA and merger parties agree timings for initial meetings (ie (as applicable) 'teach-in' (potentially in the form of a 'site visit') and/or 'initial substantive meeting').
	Response to phase 1 decision (typically expected within 14 calendar days of referral)	CMA considers responses to phase 1 decision.	Merger parties respond to phase 1 decision. Third parties respond to phase 1 decision or decision summary (if full text decision not yet published)
Around weeks 1-6	Initial information-gathering	CMA issues information requests to merger parties – including under section 109 of the Act where appropriate.  The CMA may send to the merger parties questions on aspects of the merger parties' businesses relevant to the assessment of possible remedies.  CMA issues information requests to third parties – including under section 109 of the Act where appropriate.	Merger parties and third parties respond to information requests.
		CMA develops any surveys.	Merger parties provided opportunity to comment on any draft consumer survey. <sup>277</sup>
		CMA attends initial meeting(s) with the merger parties, which will typically include a teach-in (potentially in the form of a site visit) and an 'initial substantive meeting' in which the merger parties set out their views on the competition issues raised in the phase 1 decision, expanding on their written response to the phase 1 decision (if submitted).	Merger parties organise initial meeting(s) with the CMA in consultation with CMA case team. It is anticipated that the initial substantive meeting will take place at the CMA's offices. Merger parties share the agenda for these meetings with the CMA in advance for consideration.
		CMA conducts calls, videoconferences and/or meetings with third	Third parties give oral evidence.

<sup>277</sup> The CMA does not typically share its customer or competitor questionnaires with the merger parties.

	MILESTONES	CMA	PARTIES AND THIRD PARTIES
		parties to the extent necessary to supplement existing evidence base.	
<b>STAGE 2: Preparation and publication of interim report</b>		<b>Weeks 7–14</b>	
		CMA conducts analysis of evidence.	
	Update calls	CMA will periodically hold update calls with merger parties.	Merger parties attend update calls.
	Put-back process	'Put-back' of material to merger parties and third parties as appropriate.	Merger parties and third parties review 'put-back' extracts to identify potentially confidential material, prior to disclosure of the material. <sup>278</sup>
Around weeks 12-14	Publication of interim report	CMA publishes interim report. <sup>279</sup>	
<b>STAGE 3: After interim report</b>		<b>Weeks 15–24</b>	
Around weeks 15 to 17		CMA considers responses to interim report.	Merger parties and third parties comment on interim report.
Around weeks 14 to 16	(If relevant) Publication of Invitation to Comment on Remedies up to 14 calendar days after interim report.	The CMA publishes the Invitation to Comment on Remedies and non-confidential version of merger parties' remedy proposal detailed in the Phase 2 Remedies Form.	Merger parties submit 'Phase 2 Remedies Form' and a non-confidential summary of the remedy proposal in the Phase 2 Remedies Form within 14 calendar days of publication of interim report.  Merger parties and third parties engage with the CMA on possible remedies, including the merger parties' remedy proposal and other potential remedies under consideration by the CMA.
Around weeks 16-18	Main parties' hearing	CMA holds a hearing with the merger parties (and third parties, where appropriate).	Merger parties and third parties (where appropriate) attend hearing and respond to the interim report.
	(If relevant) Consultation on	Public consultation on Invitation to Comment on Remedies and non-confidential version of merger parties' remedy proposal will normally	Merger parties and third parties attend calls/meetings with CMA.

<sup>278</sup> The CMA will typically not 'put back' text from written submissions or agreed oral evidence to parties. See further paragraph 11.53 below.

<sup>279</sup> In cases where the interim report is to be published later than week 14 the CMA will inform the merger parties as soon as practicable.

	<b>MILESTONES</b>	<b>CMA</b>	<b>PARTIES AND THIRD PARTIES</b>
	Invitation to Comment on Remedies	<p>take at least one week.</p> <p>The CMA will invite merger parties to attend at least one meeting or call to engage with the Inquiry Group on possible remedies ('remedy meetings').</p> <p>The CMA will also conduct calls/meetings with third parties to discuss remedy options.</p>	
		The CMA may engage in a further putback process for extracts of additional material to merger parties and third parties	Merger parties and third parties review 'put-back' extracts to identify potentially confidential material, prior to disclosure of the material.
		<p>CMA conducts analysis of any evidence received following the interim report.</p> <p>Following the responses to the interim report, the main parties' hearing, and any further evidence received, the CMA will provide the merger parties with an update call, setting out in broad terms the views of the Inquiry Group and the extent to which they have changed following the interim report.</p>	
	(If relevant) Remedy calls and meetings	The CMA will invite merger parties to attend at least one meeting or call to engage with the Inquiry Group on possible remedies ('remedy meetings').	
Around weeks 18-21	(If relevant) Interim Report on Remedies	Where relevant, the CMA produces the 'Interim Report on Remedies' and discloses this to merger parties for comment with a deadline of seven calendar days.	Merger parties comment on the interim report on remedies.
Around weeks 19-21		<p>CMA considers responses to the Interim Report on Remedies.</p> <p>CMA may hold a call with merger parties to discuss the Interim Report on Remedies and their response if the CMA considers this necessary.</p> <p>The CMA will determine a final date after which it will not be able to consider further representations on remedies or other aspects of the case.</p>	Merger parties attend further call with CMA on remedies if necessary.
Week 24	Statutory deadline for publication of the final	CMA publishes final report by the end of week 24 (subject to any	

	MILESTONES	CMA	PARTIES AND THIRD PARTIES
	report	extension of statutory deadline). <sup>280</sup>	
<b>STAGE 4: Implementation of remedies – after publication of the CMA’s final report (if relevant) Weeks 24 –36</b>			
Around week 25		CMA creates timetable for implementation of undertakings/order and informs merger parties of key milestones.	
Around weeks 25-26		CMA considers whether any interim measures or variation to existing interim measures are necessary.	CMA makes an interim order, varies existing interim order or merger parties accept revised or additional interim undertakings if appropriate. CMA may also consider unwinding any integration.
Until around week 30		CMA consults merger parties (and, where relevant, third parties) on draft undertakings/order.	Merger parties (and, where relevant, third parties) comment on draft undertakings/order and request excisions (if any) prior to public consultation.
Around week 30		CMA consults publicly on draft undertakings (minimum of 15 calendar days) / order (minimum of 30 calendar days).	Merger parties and third parties comment further on draft undertakings/order.
Week 36	Statutory deadline for implementation of remedies (subject to any extensions of statutory deadlines)	CMA accepts final undertakings/makes final order within statutory 12-week deadline (subject to extension by six weeks if there are special reasons to do so). Responsibility for further implementation is assigned to a Remedies Group appointed to oversee this part of the process (often the original Inquiry Group).	

<sup>280</sup> As a minimum, the CMA will make available a fully unredacted version of the Final Report to a limited number of the merger parties’ external legal (and, where appropriate, economic) advisers in a confidentiality ring, but will also consider on request, and on a case-by-case basis, whether individuals from the merger parties should be included within the confidentiality ring.



## 11. The phase 2 assessment process

11.1 This chapter addresses the following stages of the phase 2 inquiry process:

- (a) Suspension of the reference where merger parties are considering possible abandonment;
- (b) Preparatory work for the phase 2 inquiry, including administration and use of evidence gathered during phase 1;
- (c) Contact with the merger parties at the outset of the phase 2 process;
- (d) Phase 2 information-gathering, including teach-ins, initial substantive meetings, requests for information, submissions, economic evidence, third party oral evidence, joint hearings and surveys and consultants;
- (e) Update calls;
- (f) Engagement on possible remedies prior to the interim report (the details of the remedies process following the interim report are set out in Chapter 12);
- (g) The interim report;
- (h) Main party hearings;
- (i) Further evidence-gathering;
- (j) Supplementary consultation where the CMA changes its provisional decisions on the statutory questions; and
- (k) Final report.

### Suspension of the reference

11.2 Following the reference of an anticipated merger for a phase 2 investigation and within three weeks of the reference date, the CMA can suspend its phase 2 inquiry for a period of up to three weeks if the merger parties request it and the CMA reasonably believes that the merger may be abandoned by the merger parties.<sup>281</sup> This prevents wasted or unnecessary work by the CMA (and the need for merger parties and third parties to respond to initial information requests).

---

<sup>281</sup> Section 39(8A) of the Act. See chapter 13 for the process of cancelling a reference. For abandonment after the SLC decision has been issued but before a reference is made, see paragraph 13.3.

- 11.3 If the CMA suspends the investigation, it will publish, at the end of the suspension period (or earlier if the merger parties themselves announce publicly that the investigation has been suspended), a notice stating that the power was used and (if the merger was not abandoned) the date by which the CMA's phase 2 report will be published.

## **Preparatory work for the phase 2 inquiry**

- 11.4 At the time of reference, the CMA will publish the terms of its reference for a phase 2 investigation.<sup>282</sup> These terms of reference specify the transaction which is to be investigated, and summarise at a high level the basis on which the reference is made (that is, the market or markets in which the phase 1 decision maker believes there is an SLC).
- 11.5 In its phase 2 investigation, the CMA will use the evidence and information gathered in phase 1. In some cases, it may not be necessary to significantly expand this evidence base in order for the CMA to reach a properly informed decision on the phase 2 statutory competition questions.<sup>283</sup> In other cases, it will be necessary to expand this evidence base, but the CMA will seek to do so in a proportionate and targeted manner.
- 11.6 At an early stage in its phase 2 inquiry the CMA also considers the 'theories of harm' which will frame its substantive assessment of the phase 2 statutory competition question (see above) and focus any further information-gathering and analysis. Typically, the starting point at phase 2 will be the theories of harm on which the CMA determined at phase 1 that the statutory test for reference was met (and therefore the phase 1 decision should be considered to set out the theories of harm that the CMA will consider, at least initially, in its phase 2 investigation). Where at the outset of a phase 2 investigation, there is no phase 1 decision because the case was fast tracked under the process set out at paragraph 7.13 et seq. above or the Inquiry Group intends to investigate theories of harm that differ from those on which the CMA determined at phase 1 that the statutory test for reference was met,<sup>284</sup> the CMA's case webpage will make clear which theories of harm the Inquiry Group intends to investigate. The CMA's

---

<sup>282</sup> Pursuant to either [section 22](#) (completed mergers) or [section 33](#) (anticipated mergers) of the Act. In certain cases raising public interest considerations the reference is made by the Secretary of State; see chapter 14.

<sup>283</sup> That is, firstly, whether or not a relevant merger situation has been (or will be) created and second, if so, whether or not the relevant merger situation has resulted, or may be expected to result, in an SLC within any market or markets in the UK for goods or services.

<sup>284</sup> This includes, for example, water mergers or mergers of energy networks which have been fast tracked to phase 2 investigation under the administrative fast track process where the phase 1 decision may refer to a single theory of harm and the Inquiry Group intends to investigate additional theories of harm.

theories of harm may evolve during the course of the inquiry in light of further evidence received and analysis undertaken.

- 11.7 The CMA also considers how best to conduct the phase 2 inquiry and draws up an administrative timetable which reflects the statutory time limits for investigations. The merger parties are sent a draft of the administrative timetable and the final version is published on the CMA's inquiry case page.

### **Contact with the merger parties at the outset of the phase 2 process**

- 11.8 Following a reference from phase 1, the CMA will send the merger parties a phase 2 'opening letter'. This letter marks the formal start of the phase 2 inquiry. The phase 2 opening letter typically:
- (a) confirms the names of the panel members appointed to be the Inquiry Group (and the name of the chair of the Inquiry Group);
  - (b) covers important administrative details, for example, requesting information about the availability of the merger parties and any advisers during the inquiry period;
  - (c) in some cases, may be accompanied by an information request issued under [section 109](#) of the Act. The scope of any such information request will be determined primarily by the nature of information already gathered by the CMA at phase 1, on which it seeks to build. Where the CMA considers any information already provided at phase 1 to be sufficient for the purposes of starting a phase 2 inquiry, it will not ask merger parties to submit it again, but may (where relevant) ask for it to be updated to cover the time period (and any relevant developments or changes) since its original submission;
  - (d) invites written comments from the merger parties on the CMA's phase 1 decision, setting a deadline for their submission;<sup>285</sup>
  - (e) proposes dates for initial meeting(s) with the merger parties; and
  - (f) invites the merger parties to participate in:
    - (i) a joint 'case management meeting' with the case team.<sup>286</sup> This meeting is an opportunity for the merger parties' legal advisers to discuss the phase

---

<sup>285</sup> The CMA would typically expect to set a deadline of no longer than 14 calendar days from the date of referral.

<sup>286</sup> In most instances this meeting will take place via a call rather than an in-person meeting.

2 timetable and administrative arrangements<sup>287</sup> and to ask the CMA questions about the phase 2 process; and

(ii) if necessary, a separate data meeting or meetings with each of the merger parties. These are an opportunity for the case team to discuss what (if any) relevant additional or updated data, internal documents and other information sources, not already drawn on during the phase 1 investigation, may be available to the merger parties. This helps to focus subsequent information requests, which will usually be sent under [section 109](#) of the Act. The CMA will therefore request that representatives of the merger party who are familiar with that party's data and internal records/documents attend this meeting;

(g) refers:

(i) to the ongoing applicability and effect of any IEOs made during the phase 1 investigation, including the need for an interim order if any variation may be required to such order(s) or any additional interim measures that may be necessary;<sup>288</sup> and

(ii) in the case of anticipated mergers where no interim measures are in place, to [section 78](#) of the Act, which prohibits the acquiring company from acquiring, without the CMA's consent, an interest in shares in a company if any enterprise to which the reference relates is carried on by or under the control of that company;<sup>289</sup> and

(h) explains to the merger parties the opportunities that are available during the phase 2 investigation to engage in without prejudice discussions of potential remedies with the CMA and ask whether the merger parties wish to engage in such discussions at an early stage.

## Phase 2 information-gathering

11.9 The theories of harm (see paragraph 11.6 above) form the framework for any subsequent information gathering by the CMA from both the merger parties and third parties. Information may be gathered by various means, including

---

<sup>287</sup> For example, timings of the 'teach-in' (including any 'site visit'), the 'initial substantive meeting' and 'main party hearings', and the deadline for the merger parties' response to the phase 1 decision.

<sup>288</sup> On referral to a phase 2 investigation, the CMA will consider whether any or additional interim measures are necessary. For further information on the CMA's approach to interim measures, see [Interim measures in merger investigations \(CMA108\)](#).

<sup>289</sup> Subject to [section 79](#) of the Act.

questionnaires, submissions, hearings, telephone or videoconference calls, surveys and site visits. Information-gathering takes place throughout the phase 2 inquiry. However, as set out in paragraph 11.5 above, the CMA's 'starting point' will be the evidence base obtained at phase 1 and, in some cases, it may not be necessary to significantly expand this evidence base.

### ***Teach-in***

- 11.10 During the first two weeks of the phase 2 inquiry, the case team will typically arrange an initial 'teach-in' meeting, attended by the Inquiry Group and members of the case team. A 'teach-in' may be an 'in-person' event or by videoconference and may also involve a site visit where appropriate in light of the nature of the businesses involved. The CMA will typically provide an indication to the merger parties no later than at the case management meeting if it considers a site visit to be necessary.
- 11.11 A teach-in is an opportunity for the CMA to gain a greater practical understanding of the merger parties' businesses and the products/services that they offer, and to engage with key commercial and operational staff. Merger parties are encouraged to organise presentations explaining the nature of their businesses and if it includes a site visit, a tour of the relevant business areas (where appropriate and possible) and to provide an opportunity for the CMA to ask questions.<sup>290</sup> The CMA may also ask the merger parties to present on particular issues of relevance in the inquiry to help inform its understanding of these issues.
- 11.12 An introductory teach-in may not be necessary where the markets at issue are not complex or where the CMA has previous experience of the sector. Given the purpose of the teach-in, such a meeting will typically not be held where a suitable date cannot be found within the first two weeks of the phase 2 inquiry.<sup>291</sup>

### ***Initial substantive meeting***

- 11.13 The CMA will invite the merger parties to make written submissions on the CMA's phase 1 decision (paragraph 11.8(d)), typically with a deadline of no longer than 14 calendar days from the date of referral. Following receipt of the merger parties' written submissions on the phase 1 decision (and any teach-in

---

<sup>290</sup> Although these are intended to be scene-setting meetings, where appropriate, the CMA may disclose to other parties non-confidential versions of material presented to it.

<sup>291</sup> Merger parties may therefore wish to consider the availability of the key commercial and operational staff who would attend a teach-in meeting during the window within which such a meeting might take place prior to any reference being confirmed.

meeting that takes place), the case team will also arrange an ‘initial substantive meeting’.<sup>292</sup> This meeting will generally take place within the first six weeks of the phase 2 inquiry.

11.14 Whereas the purpose of any teach-in is for the CMA to better understand the merger parties’ businesses and products/services, this meeting is an opportunity for the merger parties to present their views on the substantive competition issues set out in the phase 1 decision to the Inquiry Group and case team. The Inquiry Group and CMA staff will also ask any initial questions they have on the merger parties’ case. The meeting may be an ‘in-person’ event or by videoconference. If this meeting is in-person, it will typically be held at the CMA’s offices.

11.15 In some cases, the CMA may also hold initial substantive meetings with key third parties.

### ***Requests for information***

11.16 As soon as practicable after the start of the phase 2 inquiry, the CMA is likely to issue the merger parties with questionnaires requesting any additional information to supplement the phase 1 evidence base. The CMA may also issue the merger parties with questions to assist in any remedies assessment.

11.17 Third parties will generally not be subject to the same degree of information-gathering in the phase 2 inquiry process as the merger parties.<sup>293</sup> However, some will receive information requests (which may be under [section 109](#) of the Act where appropriate) and may be invited to give oral evidence (see paragraphs 11.33 and 11.34 below).

11.18 Because of the strict phase 2 statutory deadlines that the CMA has to meet, it is essential that the CMA gathers the bulk of any additional information that it may require for its phase 2 analysis early in the process (notwithstanding that it may need to make further requests for information as the inquiry progresses).

11.19 Requests for information may be made informally or using the CMA’s formal powers (see paragraphs 9.7 to 9.14 above). The CMA may discuss the proposed request for information with the recipient in advance of being issued where this is considered appropriate, for example having regard to the scope and/or subject of the request. Requests for information from third parties may be issued on a

---

<sup>292</sup> The CMA will publish a non-confidential version of the parties’ submission on the phase 1 decision.

<sup>293</sup> In cases where third parties have a significant role in the industry affected by the merger, third party input may be more substantial.

voluntary basis in the first instance but the CMA may decide to use its [section 109](#) information-gathering powers in relation to third parties where it considers this appropriate – for example, where delay or failure to respond to a voluntary request affects the ability of the CMA to progress its investigation, and/or if the CMA has doubts about whether it will receive a full or timely response to an informal request. Whether information is requested on an informal or formal basis, it is important that recipients, as soon as possible after receiving a request for information, inform the CMA of any difficulties they may have in meeting the deadline for providing the information or in submitting the information in the requested format. Such discussions may enable the CMA to vary the information request or the stipulated response date (where appropriate).

- 11.20 It is important that merger parties (and third parties) respond to information requests fully and accurately. As at all other stages of the CMA's investigation, intentional or reckless provision of false or misleading information is a criminal offence and can result in a fine, regardless of whether that information has been required by a notice under [section 109](#) of the Act or has been provided voluntarily.<sup>294</sup> Intentional alteration, suppression or destruction of any documents a person is required to produce by a notice under [section 109](#) of the Act is also an offence.<sup>295</sup> (See also paragraphs 9.12 to 9.14, and paragraphs 9.34 to 9.43 above.)
- 11.21 The failure to comply with a notice under [section 109](#) of the Act can cause delay to the inquiry timetable. If a relevant party<sup>296</sup> fails to comply with a 'section 109 notice', this permits the CMA to extend the relevant statutory timetable until the party has produced the documents and/or supplied the information and the CMA has assessed whether the documents and/or information form a satisfactory response to its section 109 notice (commonly known as 'stopping the clock').<sup>297</sup>

---

<sup>294</sup> [Section 117](#) of the Act and section 110(1A) introduced by the DMCC Act.

<sup>295</sup> Section 116A of the Act introduced by the DMCC Act.

<sup>296</sup> In this context, this does not include third parties who are not connected to the merger parties.

<sup>297</sup> The CMA has 'stopped the clock' in a number of phase 2 merger cases for failure to comply with the requirements of section 109 notices. See for example: the completed acquisition by Vanilla Group Ltd (JLA) of Washstation Ltd (1 May 2018); the completed acquisition by Facebook, Inc (now Meta Platforms, Inc) of Giphy, Inc. (7 June 2021); the anticipated merger of Cargotec Corporation and Konecranes Plc (11 August 2021); the completed acquisition by Sony Music Entertainment of AWAL and Kobalt Neighbouring rights businesses from Kobalt Music Group Limited (3 November 2021); the completed acquisition by Veolia Environnement S.A. of a minority shareholding in Suez S.A. and the anticipated public takeover bid by Veolia Environnement S.A. for the remaining share capital of Suez S.A. (7, 11 and 21 January 2022); the completed acquisition by Dye & Durham (UK) Limited of TM Group (UK) Limited (8 February 2022); the anticipated acquisition by Hitachi Rail, Ltd of Thales SA's Ground Transportation Systems Business (9 and 13 January 2023); the anticipated acquisition by Adobe Inc. of Figma, Inc. (16 August 2023).

11.22 The failure to comply with a section 109 notice without reasonable excuse can also result in the imposition of a fine.<sup>298</sup> Whether the CMA decides to impose a penalty and/or stop the clock will reflect various factors, including the impact that any failure to comply has had on the investigation, and the significance or flagrancy of the failure to comply. Further guidance on the CMA's approach to penalties is set out in [Administrative Penalties: Statement of policy on the CMA's approach \(CMA4\)](#).

## **Submissions**

### *Main stages where merger parties are invited to make written submissions*

11.23 The merger parties are invited to make written submissions at different stages in the process. In particular, at the outset of the phase 2 investigation, merger parties are invited to make submissions in response to the phase 1 decision, setting out their position in relation to the basis for the reference, and the main arguments and evidence that they consider that the CMA should consider during the phase 2 investigation. In response to the interim report, the merger parties have the opportunity to make submissions on the CMA's provisional decision, including the full reasoning and basis in evidence for that position. During the inquiry, the CMA may, at the CMA's discretion, also seek the merger parties' views in writing on discrete aspects of the evidence and analysis being considered by the CMA.<sup>299</sup>

11.24 Opportunities are also provided to make written submissions in relation to possible remedies. Where merger parties wish to engage on possible remedies on a without prejudice basis prior to the interim report, a written submission (such as a draft Phase 2 Remedies Form) is likely to be a constructive way to begin engagement with the CMA (paragraphs 11.47 and 11.48). Where an SLC has been provisionally identified, and remedies are envisaged, merger parties have the opportunity to make written submissions on possible remedies in the

---

<sup>298</sup> The CMA has imposed fines in a number of merger cases for failure to comply with the requirements of section 109 notices. See penalty notices related to CMA Decisions: the anticipated acquisition by Just Eat.co.uk Limited of Hungryhouse Holdings Limited (24 November 2017); the anticipated acquisition by AL-KO Kober Holdings Limited of Bankside Patterson Limited (21 May 2019); the completed acquisition by Rentokil Initial plc of MPCL Limited (7 August 2019); the anticipated acquisition by Sabre Holdings Corporation of Farelogix Inc. (27 September 2019); Anticipated acquisition by Amazon.com, Inc of a minority shareholding and certain rights in Roofoods Ltd (Deliveroo) (26 August 2020); and the completed acquisition by Copart, Inc. of Green Parts Specialist Holdings Ltd (Hills Motors) (10 August 2023).

<sup>299</sup> For example, the CMA might share a version of a significant submission received from a third party or an initial piece of economic analysis.



Phase 2 Remedies Form, and in response to the invitation to comment on remedies and the CMA's interim report on remedies (see chapter 12).<sup>300</sup>

- 11.25 A CMA phase 2 investigation is formal in nature and the process is not well suited to accommodating unsolicited written submissions. Merger parties and their advisers may wish to take into account that focusing their written submissions on the key stages described in paragraphs 11.23 and 11.24 above is the optimal means of engaging with the Inquiry Group. As noted above, the CMA may invite the merger parties to provide additional written submissions on discrete aspects of evidence or analysis being considered by the CMA, where this is likely to be useful for the efficient conduct of the investigation. Merger parties are, of course, generally encouraged to bring new information, particularly relating to changes in commercial circumstances, to the attention of the CMA as soon as possible.
- 11.26 The CMA phase 2 inquiry is bound by statutory time frames. Deadlines for submissions are intended to ensure that the CMA can fully consider those submissions, taking into account the need to properly assess the evidence provided to support those submissions and, in some cases, take further investigative steps to test those submissions. Under the applicable primary legislation, the CMA is not obliged, at any stage of a reference, including the key stages noted above, to have regard to information submitted after the deadlines where there is no reasonable explanation for not meeting such deadlines.<sup>301</sup> There may be circumstances where the CMA may not be able to take submissions provided outside the key stages into account, particularly where this would risk undermining the effective functioning of the CMA's investigation (for example by unnecessarily delaying the completion of the investigation).
- 11.27 In making submissions to the CMA, parties should provide the reasoning and evidence (including supporting documents) necessary to support the arguments or contentions made. Merger parties can, if they wish, provide this evidence by reference to previous submissions to the CMA (including submissions at phase 1). The CMA will generally publish submissions it receives (see chapter 17 for more information).
- 11.28 In contrast to many other formal proceedings, the CMA has chosen not to impose page limits on submissions. Nevertheless, unduly lengthy submissions can impede the progress of the CMA's investigation for example, by hampering

---

<sup>300</sup> The Interim Report on Remedies document is typically only disclosed to the merger parties.

<sup>301</sup> See paragraph 53(3) of [Schedule 4](#) of the ERRA13 and [Rules of procedure for merger, market and special reference groups \(CMA17\)](#), paragraphs 10.3 and 11.6.

or slowing down the CMA's ability to engage on the key issues upon which a case will ultimately turn. Merger parties are therefore strongly encouraged to consider the length of all submissions made to the CMA.

## ***Economic evidence***

### *Submissions of technical economic analysis*

11.29 When making submissions of technical economic analysis, parties should refer to the principles set out in the Competition Commission publication [Suggested best practice for submissions of technical economic analysis from parties to the Competition Commission \(CC2com3\)](#), which the CMA has adopted. Parties are encouraged to inform the CMA in advance of any proposed technical economic analysis but should be aware that the CMA will form its own independent assessment of the appropriate weight to be placed on any analysis and should not expect the CMA to agree the analytical approach in advance. Parties should also be aware that the timing of submission may also affect the weight that can be placed on any analysis due to the statutory timescales for a phase 2 inquiry.

### *Submissions of evidence based on surveys*

11.30 In some cases, merger parties submit to the CMA evidence derived from surveys, for example, of consumers, customers, or suppliers; the CMA may also or alternatively commission its own surveys. In such cases, it is important that the research is statistically robust and the design and implementation of the survey is effective. If considering a survey, merger parties should refer to the principles set out in the CMA's [Good practice in the design and presentation of customer survey evidence in merger cases \(CMA78\)](#).

11.31 As with technical economic analysis, merger parties are encouraged to inform the CMA in advance of any proposed survey but should be aware that the CMA will form its own independent assessment of the appropriate weight to be placed on any survey evidence and should not expect the CMA to agree the survey approach in advance. Merger parties should also be aware that the timing of submission may also affect the weight that can be placed on any survey evidence due to the statutory timescales for a phase 2 inquiry.

### *Economist calls*

11.32 Where appropriate, the CMA case team's economists or other specialist advisers may hold discussions with the merger parties' economic advisers on particular evidence or aspects of the CMA's analysis, such as proposed methodologies. Such discussions may be particularly relevant if the theories of harm being

considered are novel or complex, if the CMA is considering undertaking complex quantitative analysis (such as econometric analysis), or if parties' submissions are technical in nature, and where the CMA wishes to understand in greater detail, for example, the methodology or assumptions proposed by the merger parties' economic advisers.

- 11.33 Economist calls may not be an appropriate use of the CMA's resources in all cases (eg in cases where the theories of harm are straightforward and no complex analysis is envisaged), and the CMA has the discretion to decline to participate in such a call where it considers that it is unlikely to be useful. These calls are intended to be informal in nature and to provide an opportunity for an open exchange of views between the CMA and the merger parties' economic advisers. Any information or views shared during update calls do not represent findings (provisional or final) of the Inquiry Group and any information or views provided during the calls will be subject to change as the inquiry progresses.
- 11.34 In the CMA's experience, economists calls tend to be most productive where participation is limited to the merger parties' economic consultants. Nevertheless, the merger parties' external legal advisers may attend the calls in an observational capacity but (in keeping with the purpose of the discussions) would be expected not to play an active role. Where the CMA considers that an economist call is not being used for its proper purpose, it may terminate the call.

### ***Third-party oral evidence***

- 11.35 Where a third party is asked to give oral evidence (which will usually be by telephone/videoconference call but may occasionally be in person) the discussion will typically be led by the case team, although Inquiry Group members may also participate. The CMA will record the telephone/videoconference call, having informed the counterparty before doing so. In some circumstances (for example, a merger which has attracted significant public interest), the CMA may consider that it is appropriate to publish a summary of third-party oral evidence on the case page.<sup>302</sup>
- 11.36 In the case of completed mergers, the CMA may wish to seek views on the merger from those associated with the acquired business, separately from any submissions or oral evidence from the acquirer. For example, senior management of the acquired business, who have transferred to the acquirer,

---

<sup>302</sup> If a summary of third-party oral evidence is to be published then, prior to its publication, the summary will be sent to the relevant third party for checking of factual accuracy and for the identification of any confidential material. The CMA will then consider whether the material is within the scope of [Part 9](#) of the Act.

may be asked to give evidence separately from the acquirer. In addition, the seller, including any senior management of the acquired business that have left the organisation and professional advisers to the business (such as financial or insolvency advisers), may be required to provide information or give evidence to the CMA during the course of its inquiry.

### **Joint hearings**

11.37 A private, multi-party hearing (for example, involving industry commentators or a group of industry participants, sometimes under the auspices of a trade association) may occasionally be held.<sup>303</sup> These hearings are inquisitorial in nature and the aim is to allow the CMA to put questions to the parties, probe responses and test the strength of the submissions and evidence previously provided to the CMA by the parties.

### **Surveys and consultants**

11.38 Where an inquiry involves a significant number of third-party suppliers or customers, or where the market is one directly affecting consumers, a survey may be a useful part of the phase 2 information-gathering process. If the CMA decides to conduct a survey, the merger parties will be consulted<sup>304</sup> on the draft survey design and survey questions.<sup>305</sup>

11.39 In cases where a survey is to be conducted, the CMA will sometimes need to obtain relevant contact details for those individuals or businesses who will be surveyed and will seek these details directly from the merger parties (and in some cases, from third parties as well).<sup>306</sup>

---

<sup>303</sup> See, for example, the CMA Final Report: Anticipated acquisition by 21<sup>st</sup> Century Fox of shares in Sky plc (5 June 2018), during which the CMA held a roundtable on issues concerning media plurality, as well as a multi-party hearing with various interested third parties. See also the CMA's investigation into the anticipated merger between J Sainsbury Plc and Asda Group Ltd where the CMA held a joint hearing with industry participants: [Transcript of hearing with Consumer Council Northern Ireland, Food and Drinks Federation, National Farmers Union, National Farmers Union Scotland and Which?](#).

<sup>304</sup> The CMA's timing constraints at this stage of its investigation means that, in some cases, the time available for this consultation will be necessarily short and merging parties may only be given one working day (at least 24 hours, not counting weekends or public holidays) to submit any comments.

<sup>305</sup> See *Tobii AB (PUBL) v CMA* [2020] CAT 1, at paragraphs 219 and 220, where the CAT found that the CMA's *Good practice in the design and presentation of consumer survey evidence in merger cases* (CMA78)) is targeted at commissioned statistical sample research surveys rather than qualitative research methods. In contrast to its stated approach regarding statistical sample research surveys, the CMA will typically not consult the merger parties on or disclose questions put to third parties as part of its evidence gathering or requests for information that are issued during the course of its investigation.

<sup>306</sup> Parties may request that the CMA require them to provide such information pursuant to its powers under section 109 of the Act, where they have regulatory or other concerns about providing the data voluntarily.

11.40 In some merger inquiries, the CMA may wish to employ a consultant to provide specialist advice on the sector concerned. Where possible, before any contract is awarded, the merger party or parties will be informed and allowed a short time to inform the CMA of any objections to the proposed consultants, which the CMA will consider prior to any appointment being finalised.

### ***Update calls***

11.41 The CMA may, at its discretion, arrange update calls with the merger parties at appropriate points of the inquiry. These calls may be used to indicate, at a high-level, areas where further evidence is likely to be needed, to identify issues on which additional submissions from the merger parties would be useful as well as to provide procedural updates to the merger parties. These update calls are designed to give the merger parties a better understanding of the progress of the inquiry, facilitate relevant submissions, and assist the merger parties in preparing any remedy proposals.

11.42 As the case advances, the CMA may be in a position to indicate (a) whether the CMA is minded not to pursue certain concerns; or (b) new concerns not previously raised with the merger parties are being considered by the CMA.

11.43 For example, after having considered the merger parties' response to the phase 1 decision and the representations made at the initial substantive meetings, the CMA may be in a position to inform the merger parties that it is no longer minded to pursue certain of the concerns set out in the phase 1 decision.<sup>307</sup>

11.44 Following the main party hearing, the CMA may also use an update call to set out, in broad terms, the current views of the Inquiry Group following consideration of the responses to the interim report from the merger parties and any third parties, and any further investigation that has been carried out. This update is also intended to assist merger parties engaging in remedies discussions, in particular by indicating whether any developments in the Inquiry Group's substantive assessment may have implications for the scope of the remedies that may ultimately be necessary.<sup>308</sup>

---

<sup>307</sup> This may, in turn, serve as a prompt for the merger parties to consider whether to engage in early-stage remedies discussions about any remaining concerns.

<sup>308</sup> The state-of-play call may disclose information regarding the Inquiry Group's evolving views on the existence and nature of any SLC. However, it will not be used to consult on (for the purposes of [section 104](#) of the Act) any changes to the CMA's provisional decisions (or the underlying 'gist' of the CMA's case) on the statutory questions to the extent this is appropriate (see paragraph 11.73).

11.45 Any information or views shared during update calls do not represent findings (provisional or final) of the Inquiry Group and any information or views provided during the calls will be subject to change as the inquiry progresses.

### **Engagement on possible remedies prior to the interim report**

11.46 From the outset of the phase 2 investigation, the CMA will start to gather information on aspects of the merger parties' businesses relevant to the assessment of possible remedies.

11.47 Merger parties are encouraged to engage with the CMA case team from an early stage during the phase 2 investigation including any time prior to the interim report. Unless the merger parties have chosen to make an SLC concession (see paragraph 7.27), any such early engagement and/or submissions will be on a 'without prejudice' basis.

11.48 Where proposed remedies are complex (eg where merger parties consider that a remedy other than divestment of a standalone business unit would be a viable remedy) there are often prima facie risks to the effectiveness of those remedies. The CMA will need sufficient time to assess such proposals, including gathering and reviewing any further evidence. Early engagement will increase the likelihood that the CMA is able to satisfy itself – within its statutory timetable – that any risks associated with the proposed remedies are not material or can be sufficiently mitigated.

11.49 Discussions regarding the development of possible remedies prior to the interim report will typically be led by the CMA case team, although members of the Inquiry Group may attend these discussions.<sup>309</sup> The CMA will consider any request from the merger parties to hold remedy discussions with the case team prior to the interim report which are not disclosed to the Inquiry Group; the case team may in some cases advise merger parties that further discussions without the involvement of the Inquiry Group would not be productive.

11.50 Where merger parties have submitted a sufficiently advanced remedy proposal at an early stage of the investigation (eg no later than four weeks after the initial substantive meeting), members of the Inquiry Group and the case team will be available for a remedies-focused meeting or call with the merger parties to discuss their draft remedy proposal well in advance of the formal remedies

---

<sup>309</sup> Discussions of remedies are without prejudice to the substantive assessment of the competition issues, and the attendance or participation of members of the Inquiry Group in such discussions is intended to help ensure that possible remedies under consideration may be considered effective by the Inquiry Group, if an SLC is ultimately identified.

process set out in chapter 12 and before publication of its interim report. The extent of feedback provided in this meeting/call will necessarily reflect the degree of detail provided in the merger parties' remedy proposal.

## **Interim report**

### ***Developing the analysis***

11.51 Following any submissions in response to the phase 1 decision and its continued information-gathering, the CMA will develop its analysis on the case prior to publishing its interim report.

### ***'Put-back'***

11.52 Towards the end of the information-gathering phase, and prior to its publication, the CMA may, where appropriate, send extracts from its draft interim report to merger parties and third parties to identify potentially confidential material, prior to disclosure of the material.

11.53 The CMA will typically not 'put back' draft text to parties to verify factual accuracy where the draft text is taken directly from information already provided to the CMA, whether in phase 1 or in phase 2 – for example, from previous written submissions, responses to written questions, or from agreed notes of oral evidence. In these cases, put back will be limited to the purpose of identifying potentially confidential information (to the extent parties have not previously been given the opportunity to indicate whether or not the information may be confidential). Submissions should not be made on the substance of the CMA's investigation or analysis through the put-back process (the opportunity for such submissions is in response to the interim report, as discussed below).

11.54 Parties should give reasons for any requests they make for material to be excised from CMA documents that are to be published (for example, its interim report), by reference to [section 244](#) of the Act (see chapter 17 for further information on publication of documents).

11.55 As the put-back process is intended to be limited to identifying confidential information (and occasionally, and typically mainly with third parties, any factual inaccuracies), the relevant parties will be given a relatively brief period to respond to put-back requests.

11.56 In the event of a disagreement on the treatment of purportedly confidential information with the Inquiry Group, the relevant party has the right to make

further representations to the CMA's Procedural Officer,<sup>310</sup> although the final decision remains with the Inquiry Group.

### ***The interim report***

- 11.57 After considering all of the relevant evidence received to that point,<sup>311</sup> the CMA publishes its interim report which represents its provisional decisions on first, whether or not a relevant merger situation has been (or will be) created and second, if so, whether or not the relevant merger situation has resulted, or may be expected to result, in an SLC within any market or markets in the UK for goods or services.
- 11.58 The interim report sets out the CMA's reasoning for its provisional decisions, as well describing the evidence upon which the CMA's position is based. The interim report will also include core information necessary to understand the inquiry (for example, details of the merger parties, and a description of the transaction). The interim report is therefore the main means the CMA uses to satisfy its duty to consult under [section 104](#) of the Act.
- 11.59 The CMA will make available a fully unredacted version of the interim report to a limited number of the merger parties' external legal (and, where appropriate, economic) advisers in a time-limited confidentiality ring, and, where requested, will also consider whether individuals from the merger parties should be included within the confidentiality ring, to ensure that the full 'gist' of the case is shared (see chapter 17). Where the Inquiry Group considers it appropriate in a particular case (ie where doing so would assist the investigation), the CMA may disclose some third-party information at an earlier stage of the investigation.
- 11.60 Alongside the interim report, the CMA will publish a Notice of interim report<sup>312</sup> and will generally issue a press release. For further information on the CMA's approach to communicating and publishing the interim report see chapter 17 below.

---

<sup>310</sup> The Procedural Officer is intended to provide a swift, efficient supplementary mechanism for resolving disputes relating to the confidentiality of information proposed to be published by the CMA. See: [Procedural Officer: raising procedural issues in CMA cases - GOV.UK \(www.gov.uk\)](#).

<sup>311</sup> Where evidence is received at a late stage prior to the publication of the CMA's interim report, that evidence may not be reflected in the interim report and may only be reflected in the CMA's final report.

<sup>312</sup> See: [CMA Rules for Merger, Market and Special Reference Groups, \(CMA 17\)](#), Rule 11.



### ***Public consultation on the interim report***

- 11.61 The interim report identifies a period (of at least 21 days) in which parties can comment on the interim report.<sup>313</sup>
- 11.62 The response(s) from parties and third parties to the interim report are published on the case page. For further information on the CMA's approach to communicating and publishing the interim report see chapter 17 below.
- 11.63 The CMA will consider all responses it receives, along with any further evidence received following the interim report, and whether its provisional assessment set out in the interim report should be altered in the light of these.

### **The main party hearing**

- 11.64 Following the interim report, and following receipt of the parties' written response to the interim report, the CMA will hold a hearing with the merger parties.<sup>314</sup> The hearing will typically consist of two parts. During the first part of the hearing, merger parties will be invited to respond orally to the interim report and will be free to use that time to focus on issues and arguments of their choosing. While the interim report sets out the CMA's provisional decisions on jurisdiction and substance, merging parties may choose to use some of the time available to them to engage with the Inquiry Group in relation to potential remedies. The second part of the hearing will be led by the Inquiry Group who, together with the case team, will test evidence and explore issues that either were not addressed in the first part of the hearing, or that they wish to explore in more detail. The CMA will hold separate calls with the merger parties to engage on possible remedies, including at least one meeting with the Inquiry Group (paragraph 12.12).
- 11.65 The main party hearing provides an opportunity for the merger parties to explain their position on issues raised in the interim report orally, directly to the Inquiry Group. Merger parties can waive their right to a main party hearing, for example where the Inquiry Group's interim report indicates that no SLC arises as a result

---

<sup>313</sup> Note that these are calendar days and run from the date on which the interim report is disclosed into the time-limited confidentiality ring referred to in paragraph 11.59, and not the date of publication on the inquiry case page.

<sup>314</sup> The Inquiry Group might wish to hold a single hearing with the merger parties or to have separate hearings. For example, in the case of a completed merger, the CMA may wish to hold a separate hearing with the sellers/former management of the acquired company. Further, the CMA may compel specified persons to attend to give evidence and may also take evidence under oath using its powers under [section 109](#) of the Act.

of the merger, or where merger parties elect at that stage to focus only on remedying the SLCs identified in the interim report.

- 11.66 The hearing will be attended by the Inquiry Group and members of the case team.<sup>315</sup> The CMA will usually find it helpful to hear from senior management in the businesses affected by the merger. The CMA will inform the merger parties if it wishes specified individuals or representatives of particular business areas to attend the hearing.
- 11.67 In some circumstances, the CMA may also wish to hear from relevant third parties, for example customers, either separately, or as part of a joint hearing with the merger parties.
- 11.68 Each merger party is permitted to be accompanied by its own external advisers at the main party hearing.<sup>316</sup> A transcript of the hearing will be taken and will be sent to the relevant merger party after the hearing for checking (the transcript is not published). The intentional or reckless provision of false or misleading information during a hearing is a criminal offence.<sup>317</sup>

## Extensions

- 11.69 The CMA's final report must normally be published<sup>318</sup> within 24 weeks of the date of the reference.<sup>319</sup> The inquiry can be extended, once only, by up to eight weeks, or by up to 11 weeks in a fast track process (see paragraph 7.25 above), if the CMA considers there are special reasons why a report cannot be prepared and published within the statutory deadline.<sup>320</sup> Special reasons constitute good, case-specific reasons which justify an extension of the normal time limit for the management and conclusion of phase 2 cases.<sup>321</sup> Exceptional circumstances which cause significant disruption to cases may also constitute a basis for

---

<sup>315</sup> The merger parties will be informed if members of the Inquiry Group are unable to attend the main party hearing.

<sup>316</sup> In some occasions, the CMA may wish to hear from one of the merger parties alone, in order to discuss information which may be commercially sensitive or otherwise restricted. It will usually be possible for the external advisers of the other merger party to remain, however, in some circumstances, the CMA may exercise its discretion to exclude such external advisers in order to encourage candour.

<sup>317</sup> [Section 117](#) of the Act.

<sup>318</sup> The CMA is responsible for publishing all its reports of merger inquiries that are not public interest cases (as to which, see chapter 14).

<sup>319</sup> [Section 39\(1\)](#) of the Act. The statutory deadline for publication will normally, for convenience, be stated in the phase 1 reference and will also be shown in the administrative timetable and on the inquiry page for the relevant inquiry at [Competition and Markets Authority cases and projects - GOV.UK \(www.gov.uk\)](https://www.gov.uk/competition-and-markets-authority/cases-and-projects).

<sup>320</sup> [Section 39\(3\)](#) of the Act and section 39(3A) of the Act (introduced by the DMCC Act). The CMA is required also to publish the reasons for any such extension (section [107\(2\)\(c\)](#) and [107\(4\)](#) of the Act).

<sup>321</sup> *C r lia Group Holding SAS v Competition and Markets Authority* [2023] CAT 54 at paragraph 305 and *C r lia Group Holdings SAS & Anor v Competition and Markets Authority* [2024] EWCA Civ 352 at paragraphs 106-113.

special reasons. Where the CMA has accepted a fast track process it may be necessary to extend the phase 2 timetable, especially in cases in which there has been limited evidence gathering and/or analysis in the phase 1 investigation.

- 11.70 The inquiry can also be extended, more than once, by agreement between the CMA and the persons carrying on the enterprises concerned for an agreed period.<sup>322</sup> The CMA may agree to an extension in order to align its proceedings with those in other jurisdictions or regulatory processes where the CMA considers that doing so will facilitate the overall efficiency of the case or the effectiveness of its investigation. Alignment of proceedings can contribute to the efficiency or effectiveness by, for example, facilitating evidence gathering or by providing an opportunity for agencies to discuss possible cross-jurisdictional remedies to ensure they are effective in all relevant regions before they are accepted or imposed. These type of efficiency or effectiveness benefits generally require discussions between agencies that are facilitated by waivers. The CMA is unlikely to agree an extension to facilitate alignment of proceedings where it does not consider that alignment will contribute to either the efficiency or effectiveness of its own review. Where the CMA considers that there would be limited benefit to the efficiency or effectiveness of an investigation through alignment of proceedings without a waiver, the CMA is unlikely to agree an extension for that purpose unless a waiver is in place. The CMA may also agree an extension to facilitate the consideration of a remedies proposal submitted at early stages of the phase 2 process (see paragraphs 11.46 to 11.50 above).<sup>323</sup>
- 11.71 In addition to an extension for special reasons and/or by agreement, the inquiry period can be extended if one of the merger parties fails (with or without reasonable excuse) to provide information in response to a formal section 109 notice within the time stated in the notice.<sup>324</sup> In this case the inquiry timetable is extended until the information is provided to the satisfaction of the CMA or the

---

<sup>322</sup> Pursuant to section 39(2A) of the Act introduced by the DMCC Act. There is no limit on the duration of the extension (or the number or extensions) that can be agreed. The duration of the extension will be case specific. The extension period can be cancelled by agreement between the CMA and the persons carrying on the enterprises concerned (section 39(7A) of the Act introduced by the DMCC Act). In relation to public interest cases, similar provisions apply except that, in addition to the agreement of the CMA and the persons carrying on the enterprises concerned, the Secretary of State's consent is also required (sections 51(2A) and (7A) of the Act introduced by the DMCC Act).

<sup>323</sup> Whilst the DMCC Act does not restrict the CMA's ability to agree to an extension to align its proceedings with those in other jurisdictions or to consider an early remedies proposal, these are the most likely scenarios in which the CMA envisages it may agree to an extension. The CMA expects that the standard procedural steps in a phase 2 process will be subject to the standard phase 2 timetable. Therefore, the CMA may not agree to an extension to, eg, collect relevant evidence, to allow additional time for the parties to make submissions to the CMA in complex cases, or consider a remedy proposal submitted by the parties late in the process.

<sup>324</sup> Section 39(4) of the Act. For further information on section 109 notices, see paragraphs 11.19 to 11.22 and paragraphs 9.9 to 9.14.

CMA decides to cancel the extension. If the inquiry timetable is extended for any reason a notice of extension will be published<sup>325</sup> and the administrative timetable will be revised and republished.

11.72 The extensions referred to in paragraphs 11.69-11.71 above, are not mutually exclusive.<sup>326</sup> This means that a period extended for one of the above reasons can also be extended for any other permitted reason.

## Supplementary consultation<sup>327</sup>

11.73 Where the CMA changes its provisional decisions on the statutory questions (or in circumstances where the ‘gist’ of the CMA’s case<sup>328</sup> fundamentally evolves) as a result of evidence received following publication of its interim report, it may be appropriate for the CMA to publish on its case page, or otherwise disclose to the merger parties and relevant third parties, a description of its reasons for changing its provisional decision (or how the ‘gist’ of the case has evolved) in order to provide parties with an opportunity to comment prior to publication of the final report. In such cases, the requirement for a minimum 21-day period for consultation on the interim report does not apply and an appropriate period for response will be set depending on the circumstances of the case in question.<sup>329</sup> In deciding whether it is necessary to publish or otherwise disclose such an update to its interim report, the CMA will in particular have regard to its statutory duties to consult where it proposes to make a relevant decision that is likely to be adverse to the interests of the merger parties.<sup>330</sup> Where the CMA consults on a

---

<sup>325</sup> Section 107(2)(c) of the Act.

<sup>326</sup> Section 40(3) of the Act (as amended by the DMCC Act).

<sup>327</sup> As noted at paragraph 11.44 above, as part of the regular update calls with the merger parties, ahead of the supplementary interim report, the CMA may be able to set out, in broad terms, the views of the Inquiry Group following consideration of any responses to the interim report from the merger parties and third parties, the main party hearing, and any further investigation that has been carried out. This may assist the merger parties in their engagement on remedies discussions.

<sup>328</sup> Determining the ‘gist’ is acutely context sensitive, and the CMA has a wide margin of appreciation in deciding what the gist of the case is. *Meta Platforms Inc v Competition and Markets Authority* [2022] CAT 26, paragraph 148(4).

<sup>329</sup> See, for example: CMA supplementary provisional findings in relation to London: completed acquisition by Ausurus Group Ltd through its subsidiary European Metal Recycling Limited of Metal & Waste Recycling Limited (19 July 2018); CMA Notice of addendum to provisional findings and possible remedies: completed acquisitions by Bauer Media Group of certain businesses of Celador Entertainment Limited, Lincs FM Group Limited and Wireless Group Limited, as well as the entire business of UKRD Group Limited (4 February 2020); CMA revised provisional findings: Anticipated acquisition by Amazon of certain rights and a minority shareholding in Deliveroo (22 June 2020); CMA addendum provisional findings: anticipated acquisition by Microsoft Corporation of Activision Blizzard, Inc. (24 March 2023); CMA addendum provisional findings: completed acquisition by Copart, Inc. of Green Parts Specialist Holdings Ltd (Hills Motors) (23 June 2023); CMA addendum provisional findings: anticipated acquisition by Hitachi Rail, Ltd of Thales SA’s Ground Transportation Systems Business (23 August 2023).

<sup>330</sup> Section 104 of the Act.

supplementary interim report, it will also invite views on whether and how any change to the scope of the provisional SLCs may impact on the possible remedy options under consideration.

## **The final report**

- 11.74 The CMA is required to publish its conclusions on the statutory questions (see paragraphs 3.1 to 3.8 above) in a report which must contain the reasons for the decisions and such information as the CMA considers appropriate for a proper understanding of the decision and the reasons.<sup>331</sup> The report will also contain the CMA's final decisions on remedies if there is an SLC finding. For further information on the CMA's approach to communicating and publishing the final report see chapter 17 below.
- 11.75 As with the interim report, prior to publication of the final report, the CMA may, where appropriate, send extracts to merger parties and third parties to identify potentially confidential material, prior to disclosure of the material. Further information on how the putback process will operate in practice is provided at paragraphs 11.52 to 11.56 above.
- 11.76 Similar to the interim report, the CMA will make available a fully unredacted version of the final report to a limited number of the merger parties' external legal (and, where appropriate, economic) advisers in a time-limited confidentiality ring, and, where requested, will also consider whether individuals from the merger parties should be included within the confidentiality ring, to ensure that the full 'gist' of the case is shared (see chapter 17).
- 11.77 If there is no SLC finding in the CMA's final report, this is the final stage in the phase 2 inquiry process.
- 11.78 Following publication of the final report, if the CMA has concluded that a merger would give rise to an SLC and that remedial action should be taken by it to remedy that SLC, the CMA will take steps to implement such remedies.

---

<sup>331</sup> [Section 38](#) of the Act.

## 12. The phase 2 remedy process

### Remedies process from interim report to final report

#### *The Phase 2 Remedies Form*

- 12.1 Where the Inquiry Group provisionally identifies an SLC in the interim report, the Inquiry Group will consider possible remedies to address those SLCs in parallel with considering responses to its interim report.
- 12.2 When considering remedies, the CMA is under a statutory duty to ‘in particular, have regard to the need to achieve as comprehensive a solution as is reasonable and practicable to the SLC and any adverse effects resulting from it’.<sup>332</sup> Although the CMA considers it is beneficial for merger parties to engage with the CMA on remedies as early as practicable in all instances, where the merger parties consider that there is a viable remedy other than prohibition or divestiture of a standalone business that could address the possible SLCs, it is particularly important for merger parties to engage in early and constructive discussions with the CMA. The specification of such remedies often requires detailed knowledge of the operation of the relevant business, and it is unlikely that the CMA could assess the effectiveness of such a remedy without significant input from the merger parties. These remedies are often complex and require detailed assessment, including a sufficiently robust evaluation of the risks that they raise. Where merger parties do not engage in sufficiently early discussions (or where they make significant modifications to remedy proposals at an advanced stage of the process), the CMA may not be able, given the constraints imposed by the CMA’s statutory timetable, to satisfy itself that the proposed remedy has an acceptable risk profile<sup>333</sup> and can therefore be considered effective.
- 12.3 In order to propose possible remedies for the Inquiry Group’s consideration, merger parties should submit a Phase 2 Remedies Form (or an updated version if a draft Phase 2 Remedies Form had already been submitted) as soon as practicable but usually no more than 14 calendar days from the notification of the

---

<sup>332</sup> Sections 35(4) and 36(3) of the Act at Phase 2.

<sup>333</sup> In evaluating the effectiveness of remedies, the CMA will seek remedies that have a high degree of certainty of achieving their intended effect. Customers or suppliers of merger parties should not bear significant risks that remedies will not have the requisite impact on the SLC or its adverse effects. See [Merger Remedies \(CMA87\)](#), at paragraph 3.5(d).

interim report.<sup>334</sup> Where merger parties consider that a remedy other than prohibition or divestment of a standalone business would be viable, that possible remedy should be explained in detail in the Phase 2 Remedies Form. The Phase 2 Remedies Form provides details of the information that will assist the CMA in understanding the merger parties' remedies proposal, including a description of any business to be divested, the divestiture process and potential purchasers, and RCBs. The merger parties must also provide a non-confidential summary of the remedy proposal (to facilitate third-party consultation) at the same time.<sup>335</sup>

- 12.4 In the Phase 2 Remedies Form, the merger parties will be expected to demonstrate that any remedy options they put forward are practicable and would be effective in addressing the provisional SLC (or SLCs) and the resulting adverse effects. The merger parties will also be expected to provide evidence to support any claims concerning RCBs including their potential for pass through to relevant customers. The level of information in the Phase 2 Remedies Form required by the CMA will vary according to the type and structure of remedy (or remedies) proposed. Merger parties are not obliged to complete all aspects of the Phase 2 Remedies Form but doing so as far as possible and relevant will enhance the CMA's ability to assess, and consult on, the merger parties' remedy proposal effectively. If merger parties consider that any particular information requested by the Phase 2 Remedies Form may not be necessary or relevant for the CMA's assessment, they should explain why this is the case. Merger parties are encouraged to engage with the case team regarding any questions on completing the Phase 2 Remedies Form sufficiently in advance of the 14 calendar days deadline.
- 12.5 Merger parties should confirm to the CMA case team whether they intend to submit a completed Phase 2 Remedies Form as soon as possible after they are notified of the CMA's interim report and in any case within three working days of publication of the CMA's interim report (see also paragraph 12.8).

### ***The Invitation to Comment on Remedies***

- 12.6 Following submission by the merger parties of the Phase 2 Remedies Form, the CMA will publish an Invitation to Comment on Remedies in order to consult on possible remedies to remedy the SLC (or SLCs) that the CMA has provisionally identified. The Invitation to Comment on Remedies serves as a basis for consultation with the merger parties and other parties, including customers,

---

<sup>334</sup> The deadline for the submission of the Phase 2 Remedies Form will be determined by the CMA on a case-by-case basis.

<sup>335</sup> See [CMA Rules for merger, market and special reference groups \(CMA17\)](#), Rule 12.



competitors and any relevant sectoral regulator. The Invitation to Comment on Remedies will invite comments from interested parties by a given date (normally within seven calendar days from its publication) on the possible remedies (including any merger parties' remedy proposal).<sup>336</sup>

- 12.7 The Invitation to Comment on Remedies will set out and consult on any remedy proposals provided by the merger parties in the Phase 2 Remedies Form (based on the non-confidential summary of the proposal). While the CMA is not limited in its consideration of the appropriate remedy to the merger parties' proposals, in anticipated mergers the CMA will generally only give detailed consideration to: (a) remedies that the merger parties have indicated that they are willing to implement; and (b) prohibition of the merger.<sup>337</sup> In such circumstances, the CMA will typically consult only on the merger parties' remedy proposal and the prohibition of the merger.
- 12.8 Where merger parties do not submit a Phase 2 Remedies Form, the CMA will issue an Invitation to Comment on Remedies based on the information available to the CMA at that time. As noted in paragraph 12.2, the specification of remedies other than prohibition or divestiture of a standalone business often requires detailed knowledge of the operation of the relevant business, and it is unlikely that the CMA could identify and develop such a remedy without significant input from the merger parties. On this basis, where the merger parties have not made a remedy proposal, the CMA will not typically give detailed consideration to remedies of this nature, and the CMA's assessment is therefore most likely, in practice, to focus on the prohibition of the merger and/or divestiture of a standalone business.
- 12.9 Non-confidential versions of the responses from the merger parties and third parties to the Invitation to Comment on Remedies are published on the case page.

### ***Further evidence-gathering and consultation on possible remedies***

- 12.10 Following the merger parties' submission of the Phase 2 Remedies Form (and prior to the Interim Report on Remedies), the CMA will continue to assess

---

<sup>336</sup> To the extent there are any confidentiality redactions in the Invitation to Comment on Remedies, the CMA will also, as a minimum, make available a fully unredacted version of the Invitation to Comment on Remedies to a limited number of the merger parties' external legal (and, where appropriate, economic) advisers in a confidentiality ring, and consider whether individuals from the merger parties should be included within the confidentiality ring, in the same way as it does for the interim report.

<sup>337</sup> The existence of alternative remedies may nevertheless be taken into account in assessing the proportionality of proposed remedies.



remedies, by gathering further evidence and consulting with the merger parties and third parties.

- 12.11 The CMA will typically obtain information and evidence from the merger parties and third parties through calls and requests for information (either under [section 109](#) of the Act or otherwise). The merger parties and third parties are encouraged to submit detailed responses and any other information or evidence they consider relevant to the CMA's consideration of remedies as early as possible. This helps to ensure that the CMA has all of the relevant information it needs to effectively evaluate the viability and effectiveness of possible remedy options within the constraints of the statutory timeframe.
- 12.12 The CMA will meet with the merger parties to engage on possible remedies during this period (including at least one in-person meeting or call with the Inquiry Group).<sup>338</sup> These meetings are intended to enable the CMA to clarify, discuss and provide feedback on the merger parties' remedy proposals (focussing, in particular, on possible areas of concern with the existing proposals). While the information or views shared during these meetings do not represent findings (provisional or final) of the Inquiry Group, the feedback provided is intended to enable the merger parties to modify their remedy proposal or consider whether additional evidence might be submitted to address the possible areas of concern identified by the CMA. The frequency and nature of these meetings will be determined by the CMA, and will depend on the circumstances of the case.
- 12.13 The CMA may also hold remedy calls with key third parties (eg potential buyers of a divestment business, significant customers or relevant sectoral regulators) who may be able to provide useful evidence or views.<sup>339</sup>
- 12.14 Remedy calls with third parties may be led by the Inquiry Group or the case team and may be held face-to-face or remotely. In some circumstances (for example, a merger which has attracted significant public interest), the CMA may consider that it is appropriate to publish a summary of third-party oral evidence on the case page.<sup>340</sup>

---

<sup>338</sup> Whether these meetings are in-person or held remotely will depend on the circumstances of the case.

<sup>339</sup> The calls with the merger parties and third parties will be held separately.

<sup>340</sup> If a summary of third-party oral evidence is to be published then, prior to its publication, the summary will be sent to the relevant third party for checking of factual accuracy and for the identification of any confidential material. The CMA will then consider whether the material is within the scope of Part 9 of the Act.

### ***Interim report on remedies***

- 12.15 An Interim Report on Remedies, containing the Inquiry Group's assessment of the different remedies options and setting out the CMA's provisional decision on remedies, will be sent to the merger parties for comment.
- 12.16 The Interim Report on Remedies will also set out the CMA's provisional views on whether the merger gives rise to RCBs, and if so, whether the proposed remedy should be modified in order to preserve those benefits. The merger parties will typically have at least seven calendar days to respond to the Interim Report on Remedies.
- 12.17 The CMA will make available a fully unredacted version of the Interim Report on Remedies to a limited number of the merger parties' external legal (and, where appropriate, economic) advisers in a time-limited confidentiality ring, and, where requested, will also consider whether individuals from the merger parties should be included within the confidentiality ring.
- 12.18 Where the Interim Report on Remedies indicates that the Inquiry Group provisionally considers that any remedies proposed by the merger parties would not be practicable or effective, the merger parties may wish to amend their remedy proposals to address the concerns that have been identified. In light of the constraints posed by the statutory timetable, which limit the further consideration of remedies at this stage of the CMA's investigation, any such amendments should clearly address the concerns identified. In particular, if the merger parties propose a new or substantially different remedy at this stage, that remedy could only be considered effective where the CMA is able to conclude, without significant further investigation, that there is a high degree of certainty in the overall effectiveness of the remedy.
- 12.19 Following the merger parties' response to the Interim Report on Remedies, the merger parties may be invited to a final remedies call with the CMA. This call, which will typically be led by the case team (although Inquiry Group members may also participate), is primarily intended to enable the CMA to clarify any aspects of the merger parties' response that may be unclear.
- 12.20 In light of the constraints imposed by the CMA's statutory timetable and the need to prepare and publish the final report setting out the Inquiry Group's final decisions on the SLC and remedies, the case team will indicate to the merger parties a deadline after which the Inquiry Group will not be able to take into account further submissions on remedies or further modifications to their remedy proposal.

12.21 Following consultation on the Interim Report on Remedies and any further discussions and evidence gathering with parties that the CMA considers necessary, the CMA will take its final decision on any remedies.

### ***Final remedy decision***

12.22 The CMA will publish its final decision on remedies, together with its supporting reasons and information, in its final report.<sup>341</sup> The report will contain sufficient detail on the nature and scope of remedies to provide a firm basis for subsequent implementation by the CMA.

## **Implementation of phase 2 remedies**

12.23 Following publication of the final report, if the CMA has concluded that a merger would give rise to an SLC and that remedial action should be taken by it to remedy that SLC, the CMA will take steps to implement such remedies.

12.24 The CMA will also consider whether interim measures should be put in place (where none are already in place) or existing interim measures varied (for example, allowing for the appointment of a monitoring trustee), pending the implementation of final remedies.

12.25 The CMA will agree draft undertakings with the merger parties, or produce a draft order, which will then be consulted on publicly. Taking into account any responses to its consultation, the CMA will then publish a 'notice of acceptance of undertakings' or a 'notice of making an order'. At this point, the inquiry will be finally determined.

12.26 The CMA is subject to a statutory deadline of 12 weeks following its final report<sup>342</sup> to accept final undertakings<sup>343</sup> or to make a final order.<sup>344</sup> This period may be extended once by up to six weeks<sup>345</sup> if the CMA considers there are special reasons for doing so.<sup>346</sup>

12.27 The CMA will normally seek to obtain final undertakings in an appropriate form from the merger parties. However, if agreement on final undertakings is not forthcoming on a timely basis, the CMA will have recourse to imposing a final

---

<sup>341</sup> [Section 38](#) of the Act.

<sup>342</sup> [Section 41A\(1\)](#) of the Act.

<sup>343</sup> [Section 82](#) of the Act.

<sup>344</sup> [Section 84](#) of the Act.

<sup>345</sup> [Section 41A\(2\)](#) of the Act.

<sup>346</sup> These time limits may be further extended where a relevant party has failed to comply with the requirements of a notice requiring the submission of evidence issued under section 109 of the Act ([Section 41A\(3\)](#) of the Act).

order. The length of time required to obtain agreed final undertakings from the merger parties following the final report will reflect, among other things, the complexity of the remedies involved and the variety of parties involved in the consultation.

- 12.28 The process of agreeing undertakings or making an order is set out fully in the CMA's guidance on [Merger Remedies \(CMA87\)](#).
- 12.29 The Inquiry Group will disband following its acceptance of final undertakings or the imposition of a final order to implement remedies. Responsibility within the CMA for any further implementation of remedies (eg overseeing any divestiture process) will pass to a 'Remedies Group' appointed to oversee this part of the process (usually comprising the same members as the Inquiry Group).

## 13. The abandonment process

- 13.1 In some cases, an anticipated merger may be abandoned by the merger parties during the course of the CMA's review.
- 13.2 In order to be satisfied that the merger parties have abandoned the merger, the CMA will require sufficient evidence that this is the case. The CMA may seek written assurances directly from the merger parties (from persons of suitable seniority and with authority to bind the acquirer).
- 13.3 If an anticipated merger is abandoned during phase 1, either before the CMA takes a decision on the statutory questions or after an SLC has been found at phase 1 but before reference (for example, during the period when the CMA is waiting to receive a UIL offer), the CMA may instead decide that the merger is insufficiently likely to proceed to justify making a reference to phase 2.<sup>347</sup>
- 13.4 [Section 37\(1\)](#) of the Act requires the CMA to cancel a phase 2 reference if it considers that the proposal to make arrangements of the kind mentioned in the reference has been abandoned.<sup>348</sup> Where it is claimed that the arrangements have been abandoned and new arrangements are proposed or contemplated, the CMA must be satisfied that the arrangements that are described in the terms of reference have, in fact, been abandoned and that the new arrangements are not merely an amended form of the arrangements that were referred.<sup>349</sup>
- 13.5 If an Inquiry Group has not been constituted, or an Inquiry Group has not held its first meeting, the Chair of the CMA is able to cancel a reference where he or she is satisfied that arrangements have been abandoned.<sup>350</sup> If an Inquiry Group has been appointed and has held its first meeting, it falls to the Inquiry Group to cancel the reference.

---

<sup>347</sup> [Section 33\(2\)\(b\)](#) of the Act. The Act does not require such decisions to be published, but the outcome will be indicated on the case page (where there is one). See, for example, CMA Decisions: Anticipated acquisition by Safetykleen UK Ltd of Pure Solve UK Limited (11 May 2016); Anticipated acquisition by Mzuri Group Ltd of Shuttercraft Holdings Limited (29 November 2022).

<sup>348</sup> As discussed in paragraphs 11.2 and 11.3 above, the CMA may also, within three weeks of the reference and at the request of a relevant person connected to the merger parties, suspend the phase 2 timetable for up to three weeks if the CMA reasonably believes that an anticipated merger might be abandoned ([section 39\(8A\)](#) of the Act). If during this suspension the merger parties abandon the merger, the CMA will cancel the reference. For examples of phase 2 inquiries that were suspended by the CMA, and for which the merger was subsequently abandoned by the merger parties, see: the anticipated acquisition by McGraw-Hill Education, Inc of Cengage Learning Holdings II, Inc (2020); the anticipated acquisition by Ritchie Bros. Auctioneers Incorporated of Euro Auctions Group (2022); and the anticipated joint venture between ForFarmers N.V. (via ForFarmers UK Holdings Limited) and Boparan Private Office Limited (via Amber REI Holdings Limited) concerning ForFarmers UK Limited and 2 Agriculture Limited (2023).

<sup>349</sup> *R v MMC and SoS for Trade and Industry ex parte Argyll Group* [1986] 2 All ER 257.

<sup>350</sup> [Schedule 4](#) to ERRA13 at paragraph 47.

13.6 Merger parties may seek cancellation of a reference at any time prior to final determination of that reference.<sup>351</sup>

13.7 The CMA has no power to cancel an investigation of a completed merger.

---

<sup>351</sup> In circumstances where only part of the arrangements under consideration have been abandoned, it may be appropriate for the CMA to continue its investigation.

## 14. Public interest mergers

### Introduction to public interest mergers

- 14.1 The Act provides that (as the default position) the CMA decides whether or not to refer the merger for a phase 2 investigation, and that the phase 2 Inquiry Group makes the final decision as to whether any competition issues arise and whether any remedies are required, based purely on whether the merger has caused or may cause an SLC. However, the Act also allows for the Secretary of State to assume responsibility for determining whether or not to refer a merger when defined public interest considerations are potentially relevant by issuing a public interest intervention notice (PIIN). If the Secretary of State has referred a merger on such public interest grounds, he or she also takes the final decision on whether the merger operates or may be expected to operate against the public interest, and on any remedies for identified public interest concerns.
- 14.2 [Section 42](#) of the Act provides that the Secretary of State may issue a PIIN in the case of mergers that meet the Act's jurisdictional thresholds (set out in paragraph 4.3 above), that have public interest implications,<sup>352</sup> and which the CMA has not referred for a phase 2 investigation.
- 14.3 To facilitate this, the CMA has an obligation under [section 57](#) of the Act to inform the Secretary of State where it is investigating a merger (at phase 1) that it believes raises material public interest considerations.

### Public interest considerations

- 14.4 [Section 58](#) of the Act details the public interest considerations on which the Secretary of State may intervene in a merger case. These are:<sup>353</sup>
- (a) plurality and other considerations relating to newspapers and other media, specifically:<sup>354</sup>

---

<sup>352</sup> The Secretary of State may also intervene in certain public interest cases where the jurisdictional thresholds are not met (see 'public interest in special merger situations' below; paragraph 14.14 *et seq.*).

<sup>353</sup> The list of public interest considerations under [section 58](#) of the Act previously included national security. This consideration was removed by [section 58](#) of the NSI Act on 4 January 2022.

<sup>354</sup> See, for example, OFT Decisions: Acquisition by British Sky Broadcasting of a 17.9% stake in ITV plc (27 April 2007); Completed acquisition by Global Radio Holdings Limited of GMG Radio Holdings Limited (2012); CMA Final Report: Anticipated acquisition of Sky plc by Twenty-First Century Fox, Inc. (1 May 2018); CMA Decisions: Completed acquisition by Trinity Mirror plc of certain assets of Northern & Shell Media Group Limited (20 June 2018); and Completed acquisition by DMG Media Limited of JPIMedia Publications Limited (27 March 2020).

- (i) the need for accurate presentation of news and free expression of opinion in newspapers;
  - (ii) the need for, to the extent that it is reasonable and practicable, a sufficient plurality of views in newspapers in each market for newspapers in the UK or a part of the UK;
  - (iii) the need, in relation to every different audience in the UK or in a particular area or locality of the UK, for there to be a sufficient plurality of persons with control of the media enterprises serving that audience;
  - (iv) the need for the availability throughout the UK of a wide range of broadcasting which (taken as a whole) is both of high quality and calculated to appeal to a wide variety of tastes and interests; and
  - (v) the need for persons carrying on media enterprises, and for those with control of such enterprises, to have a genuine commitment to the attainment in relation to broadcasting of the standards objectives set out in [section 319](#) of the Communications Act 2003;<sup>355</sup>
- (b) the interest of maintaining the stability of the UK financial system;<sup>356,357</sup> and
- (c) the need to maintain in the UK the capability to combat, and to mitigate the effects of, public health emergencies.<sup>358</sup>

14.5 In addition to the specified considerations outlined above, [section 42\(3\)](#) of the Act also allows the Secretary of State to intervene on the basis of a consideration which is not specified but which the Secretary of State believes ought to be specified. To the extent that the Secretary of State intervenes on the basis of a consideration that he or she believes ought to be specified, he or she is required by [section 42](#) of the Act to seek to have that consideration subsequently inserted into [section 58](#) of the Act by means of an order approved by both Houses of Parliament.

---

<sup>355</sup> The media considerations were added by the Communications Act 2003. See also BEIS (formerly DTI) Guidance: [Enterprise Act 2002: Public Interest Intervention in Media Mergers: Guidance on the operation of the public interest merger provisions relating to newspaper and other media mergers \(May 2004\)](#).

<sup>356</sup> Added by the Enterprise Act 2002 (Specification of Additional Section 58 Consideration) Order 2008 SI 2008/2645.

<sup>357</sup> See, for example, OFT Decision: Anticipated acquisition by Lloyds TSB plc of HBOS plc (31 October 2008).

<sup>358</sup> Added by the Enterprise Act 2002 (Specification of Additional Section 58 Consideration) Order 2020 SI 2020/627. See also BEIS Guidance: [Enterprise Act 2002: Changes to the public interest grounds for intervention in merger cases \(June 2020\)](#).



## Process for public interest cases

### Phase 1

14.6 If a PIIN is issued, the case is handled in the following way:

- (a) The CMA will publish an invitation to comment seeking third party views on both competition and public interest issues.
- (b) As well as generally issuing an invitation for comment, the CMA will actively contact other governmental departments, sectoral regulators, industry associations and consumer bodies for their views on public interest issues where appropriate. In media public interest cases, [section 44A](#) of the Act provides expressly for a report by Ofcom.<sup>359</sup>
- (c) The CMA will carry out its review of the jurisdictional and competition issues in a similar way as it would for any other case, with the caveat that its process and timetable will be adapted in order to enable it to provide its report to the Secretary of State by the deadline specified in the PIIN.
- (d) The CMA then provides advice to the Secretary of State on jurisdictional and competition issues, which must be accepted ([section 46](#) of the Act). The CMA is also required to pass to the Secretary of State a summary of any representations it has received that relate to the public interest matters.<sup>360</sup> The Act allows the CMA to provide advice and recommendations on the public interest consideration to the Secretary of State; however, given the CMA's role as a competition agency, the CMA would not normally provide its advice on public interest issues at phase 1. (By contrast, following a reference on public interest grounds, the independent phase 2 Inquiry Group will report to the Secretary of State about whether the merger operates or may be expected to operate against the public interest: see further paragraph 14.8 below.)

---

<sup>359</sup> In phase 1 cases in which the Secretary of State has intervened on media public interest grounds, Ofcom will advise the Secretary of State on the public interest aspects of the case under [section 44A](#) of the Act. Ofcom may also advise the Secretary of State at phase 2, following receipt of the CMA's phase 2 report.

<sup>360</sup> The position is different in cases raising media public interest issues where Ofcom will provide a separate report on issues of media plurality and diversity. See, for example, OFT Decision: Acquisition by British Sky Broadcasting Group plc of 17.9% per cent stake in ITV plc (27 April 2007); and CMA Final Report: Anticipated acquisition by 21<sup>st</sup> Century Fox, Inc of Sky plc (1 May 2018). The CMA may also summarise any representations it has received that relate to the media public interest.

- (e) The CMA will also inform the Secretary of State about the applicability of any of the exceptions to the duty to refer and as to whether it would be appropriate to deal with any competition concerns by way of UILs.<sup>361</sup>
- (f) The Secretary of State then makes a decision on the outcome of the case in the light of the CMA's advice.<sup>362</sup> References for a phase 2 investigation can be made under [section 45](#) of the Act either:
  - (i) because the Secretary of State believes that a relevant merger situation has been created or arrangements are in progress or in contemplation which, if carried into effect, will result in the creation of a relevant merger situation and it is or may be the case that the merger has resulted, or may be expected to result, in an SLC and, combined with the relevant public interest consideration(s), the merger operates or may be expected to operate against the public interest; or
  - (ii) while there is no realistic prospect of an SLC arising from the merger, because the public interest considerations are such that it is or may be the case that the merger operates or may be expected to operate against the public interest.<sup>363</sup>
- (g) Alternatively, the Secretary of State may decide under [section 45\(6\)](#) of the Act not to make a reference on the basis that an anti-competitive outcome in the form of a CMA finding of a realistic prospect of an SLC is justified by one or more public interest considerations.<sup>364</sup>
- (h) Where the Secretary of State is minded to refer the case for a phase 2 investigation, he or she will also consider whether UILs are justified.

14.7 If the Secretary of State concludes, after receipt of the CMA's report, that there are no public interest issues that are relevant to the PIIN, the CMA will be instructed under [section 56](#) of the Act to deal with the merger as an ordinary merger case.<sup>365,366</sup>

---

<sup>361</sup> Sections [44\(4\)](#) and [44\(5\)](#) of the Act.

<sup>362</sup> [Section 45](#) of the Act does not provide a specific time limit within which this decision must be taken.

<sup>363</sup> See OFT Decision: Anticipated acquisition by News Corporation of British Sky Broadcasting Group plc (30 December 2010).

<sup>364</sup> See OFT Decision: Anticipated acquisition by Lloyds TSB plc of HBOS plc (31 October 2008).

<sup>365</sup> See, for example, CMA Decision: Completed acquisition by Trinity Mirror plc of certain assets of Northern & Shell Media Group Limited (20 June 2018).

<sup>366</sup> Under [section 34ZB\(4\)](#) of the Act, the CMA may in those circumstances extend the 'standard' 40 working day deadline to decide whether its duty to make a reference for a phase 2 investigation applies.

## **Phase 2**

- 14.8 If a reference is made on public interest grounds (whether or not there are any competition concerns), the CMA conducts a phase 2 inquiry and reports to the Secretary of State. If the CMA considers that the merger operates or may be expected to operate against the public interest, it makes recommendations as to the action the Secretary of State (or others) should take to remedy any adverse effects. The Secretary of State will make the final decision on the public interest test and take whatever remedial steps he or she considers necessary to address the competition and public interest issues.
- 14.9 The CMA's phase 2 procedures for public interest inquiries are similar to those for ordinary merger references. The principal differences are that the CMA provides its report to the Secretary of State and the final decision on public interest matters lies with the Secretary of State. The CMA has to prepare a report and give it to the Secretary of State within 24 weeks (subject to a possible eight-week extension) from the date of the reference. The Act does not require the CMA to consult the Secretary of State in the event that the CMA proposes to extend the inquiry. The deadline to give the report to the Secretary of State can also be extended (more than once) by agreement between the CMA and the persons carrying on the enterprises concerned, for an agreed period, if the Secretary of State consents to the agreed extension.<sup>367</sup>
- 14.10 Once the Secretary of State has received the CMA's report, he or she has 30 days in which to make and publish his or her decision.<sup>368</sup> The Secretary of State is bound by the CMA's decision on whether there is a merger situation and its findings on whether or not there is an SLC, but must decide on whether there is a concern in relation to the specified public interest issue. The Secretary of State must have regard to the findings in the CMA's report regarding remedies, but can also decide on remedies other than those the CMA has recommended. If the Secretary of State decides that the public interest issue does not raise a concern, the case will be sent back to the CMA to decide how to remedy any competition issue identified.<sup>369</sup>
- 14.11 There may also be further procedural differences applicable to a PIIN case and a typical merger investigation focussing purely on competition grounds, to reflect the different statutory questions at issue, differences in the assessment which is required to answer the statutory questions at issue, as well as differences in the

---

<sup>367</sup> Section 51(2A) of the Act introduced by the DMCC Act.

<sup>368</sup> [Section 54\(5\)](#) of the Act.

<sup>369</sup> See [Merger remedies \(CMA87\)](#) for more information on the CMA's approach to remedies in the context of public interest mergers.

CMA's approach to engagement with the merger parties and third parties. As part of its inquiry, the CMA will typically engage other governmental departments as relevant third parties. The degree to which the CMA seeks information and views from governmental departments, relative to other parties, will depend on the nature and scope of the phase 2 inquiry. There may also be particular sensitivities around the confidentiality of information which may include national security considerations (if applicable) that would require the CMA to amend its typical approach to an ordinary merger investigation.

## Publication of decisions

14.12 When the Secretary of State has made a decision as to whether or not to refer the case for a phase 2 investigation, the Secretary of State is required under [section 107](#) of the Act to publish a non-confidential version of the CMA's phase 1 report. At phase 2, the Secretary of State must publish a non-confidential version of the CMA's final report no later than the publication of his or her decision on the case<sup>370</sup> (that is, within 30 days). The final decision on the material to be excised from the published report is made by the Secretary of State.<sup>371</sup>

## Fees

14.13 A merger fee is calculated in respect of cases in which a PIIN has been issued in the same way as for normal competition cases (see chapter 18 below).

## Public interest in special merger situations

14.14 [Section 59](#) of the Act also allows the Secretary of State to intervene in a very limited number of cases that do not qualify under the Act's general merger regime but where a specified consideration is relevant to the merger. Following the Communications Act 2003, a special merger situation may arise where the merger involves a supplier or suppliers of at least 25% of any description of newspapers or broadcasting in the UK or in a substantial part of the UK. Unlike the standard jurisdictional test, no increment to this share of supply is required. The CMA will not conduct a competition assessment in such cases.<sup>372</sup>

---

<sup>370</sup> [Section 107\(9\)\(b\)](#) of the Act.

<sup>371</sup> Accordingly, parties are not able to apply to the CMA's Procedural Officer if they disagree with any decisions in relation to excisions.

<sup>372</sup> Previously, [section 59](#) of the Act also allowed the Secretary of State to intervene in certain defence industry mergers. This was removed as a specified consideration by [section 58](#) of the NSI Act.

- 14.15 In cases where the Secretary of State has issued a special public interest intervention notice (SPIIN), the CMA will prepare a report under [section 61](#) of the Act for the Secretary of State advising on whether a special merger situation has been created. The SPIIN will set out the time period within which the CMA must provide this report to the Secretary of State. The CMA will also summarise representations that it has received relating to the considerations in the SPIIN. Given that the CMA is not expert in the considerations that would be expected to be specified in the SPIIN, it is likely to confine itself at phase 1 to summarising and commenting on the representations received by relevant third party experts, such as Ofcom.<sup>373</sup>
- 14.16 The Secretary of State may make a reference for a phase 2 investigation under [section 62](#) of the Act if he or she believes that it is or may be the case that, taking account only of the public interest consideration, the creation of the special merger situation operates or may be expected to operate against the public interest. The CMA's phase 1 report is published by the Secretary of State at the time the reference decision is announced. The final decision on the material to be excised from the published report is made by the Secretary of State.
- 14.17 Following a reference on special public interest grounds, the CMA is responsible for the conduct of the inquiry and reports its findings to the Secretary of State. The CMA would apply similar procedures to those outlined for normal mergers subject to the procedural differences set out in paragraphs 14.8 to 14.11 above relating to public interest mergers, although its assessment would be confined to the public interest issues specified in the intervention notice.
- 14.18 No merger fee is payable in special public interest cases.

## **Public interest in merger situations involving newspaper enterprises and foreign powers**

- 14.19 The Secretary of State has an obligation to intervene in a merger involving newspaper enterprises and foreign powers.<sup>374</sup> The Secretary of State must issue a foreign state intervention notice (FSIN) if he or she has reasonable grounds to suspect that a foreign state newspaper merger situation has been created, or

---

<sup>373</sup> By contrast, as described in paragraph 14.17, following a reference on special public interest grounds the independent phase 2 Inquiry Group will report to the Secretary of State about whether the merger operates or may be expected to operate against the public interest.

<sup>374</sup> Chapter 3A of the Act introduced by the DMCC Act.

arrangements are in progress or in contemplation which, if carried into effect, will result in the creation of a foreign state newspaper merger situation (FSNMS).<sup>375</sup>

14.20 A FSNMS arises if:<sup>376</sup>

- (a) the requirements to establish a relevant merger situation under the standard regime are satisfied, with some modifications;<sup>377</sup>
- (b) one of the enterprises concerned is a newspaper enterprise; and
- (c) as a result of the enterprises ceasing to be distinct, a foreign power is able to control or influence the policy of the person carrying on the newspaper enterprise or is able to control or influence that policy to a greater extent.<sup>378</sup>

14.21 If the Secretary of State issues a FSIN, the CMA will prepare a report for the Secretary of State. The FSIN will set out the time period within which the CMA must provide this report to the Secretary of State. The CMA's report will include its decision as to whether it believes that a FSNMS has been created, or arrangements are in progress or in contemplation which, if carried into effect, will result in the creation of a FSNMS.<sup>379</sup> The report will also summarise representations relevant to the case that it has received.<sup>380</sup>

14.22 If the Secretary of State receives a report stating that the CMA believes that a FSNMS has been created, or arrangements are in progress or in contemplation which, if carried into effect, will result in the creation of a FSNMS, the Secretary of State must make an order for the purposes of reversing or preventing the creation of the FSNMS.<sup>381</sup> In that situation, there will be no phase 2 process and no possibility of UILs.

14.23 The FSIN regime applies in parallel to the public interest regimes explained above.

---

<sup>375</sup> Section 70A of the Act introduced by the DMCC Act.

<sup>376</sup> Section 70A(3) of the Act (introduced by the DMCC Act).

<sup>377</sup> Schedule 6A of the Act (introduced by the DMCC Act). The standard £100 million turnover test in section 23(1)(b) is reduced to £2 million (Schedule 6A, paragraph 1(2)(a) of the Act), and the four month period in section 24 of the Act for completed mergers applies to each of the FSIN and the CMA's report.

<sup>378</sup> Schedule 6B of the Act (introduced by the DMCC Act) makes provision about the circumstances in which a foreign power is able to control or influence the policy of a person.

<sup>379</sup> The CMA's decision will be made to the phase 2 standard.

<sup>380</sup> Section 70B of the Act (introduced by the DMCC Act).

<sup>381</sup> Section 70C of the Act (introduced by the DMCC Act).

## 15. Interactions with other regulatory processes

### Mergers of water or sewerage undertakings

- 15.1 Mergers involving two or more water and sewerage or water-only companies are in certain circumstances subject to a special water merger regime. For guidance on water and sewerage mergers, see [Water and sewerage mergers: Guidance on the CMA's procedure and assessment \(CMA 49\)](#) and the statement of intent setting out an agreement on the working arrangements between the CMA and Ofwat for the special water merger regime.<sup>382</sup>

### Mergers of energy network undertakings

- 15.2 Mergers involving two or more energy network companies (ie companies active in gas transportation, electricity transmission or electricity or gas distribution) of the same type are in certain circumstances subject to a special energy network merger regime.<sup>383</sup> For guidance on special energy network mergers, see [Energy network mergers: Guidance on the CMA's procedure and assessment \(CMA190\)](#).<sup>384</sup>

### Regulated utilities

- 15.3 There are no special provisions under UK merger legislation for regulated utilities such as telecommunications, postal services, rail,<sup>385</sup> airports and air traffic services. A merger in these industries, however, may require the modification of an operating licence or give rise to other issues falling within the ambit or experience of the relevant sectoral regulator. For this reason, the CMA and the sectoral regulators work closely together on such mergers. In some cases, the sectoral regulator may issue a consultation document in respect of the merger, the responses to which will inform the views offered to the CMA. The CMA is not bound by the sectoral regulator's views but will consider them carefully.

---

<sup>382</sup> See [Water and sewerage mergers: Guidance on the CMA's procedure and assessment \(CMA49\)](#).

<sup>383</sup> Pursuant to the Energy Act 2023, which came into force on 26 October 2023.

<sup>384</sup> See [Energy network mergers: Guidance on the CMA's procedure and assessment \(CMA190\)](#).

<sup>385</sup> Entering into a rail franchise agreement constitutes an acquisition of control of an enterprise by virtue of [section 66\(3\)](#) of the Railways Act 1993. For guidance on rail franchise mergers, see [Rail franchise mergers – Review of methodologies and guidance \(CMA74\)](#).

## National security regime

- 15.4 Under the NSI Act, the Secretary of State can scrutinise and intervene in certain acquisitions that could harm the UK's national security. The national security regime, operated by the ISU, is separate from the merger control regime and a merger may qualify for review under both regimes.
- 15.5 In such circumstances, the CMA and the ISU expect to coordinate, as may be appropriate, to manage the interactions between the two regimes that may arise in specific cases.<sup>386,387</sup>
- 15.6 Merger parties are encouraged to discuss the process and timing of the review of a merger falling within the scope of both regimes with the CMA at an early stage.

---

<sup>386</sup> See further the [memorandum of understanding](#) between the department of Business, Energy and Industrial Strategy and the CMA regarding the operation of the NSI Act and the Act published on 16 June 2022 and the [guidance](#) issued by the Department for BEIS on 21 July 2021 regarding the application of the NSI Act alongside regulatory requirements.

<sup>387</sup> However, the CMA notes that, where a final order is in force or a final notification that no further action is to be taken has been given under the NSI Act, the Secretary of State can issue a direction to the CMA under the NSI Act to do or not do anything under [Part 3](#) of the Act, provided that the Secretary of State reasonably considers that the direction is necessary and proportionate for the purpose of preventing, remedying or mitigating a risk to national security. Prior to issuing any direction, the government will consult with the CMA (and with other parties where appropriate).



## 16. Multi-jurisdictional mergers

- 16.1 Some mergers qualify for merger control review in more than one jurisdiction (these mergers are referred to as ‘multi-jurisdictional’ mergers for the purposes of this guidance). For multi-jurisdictional mergers, there can be substantial benefits (to merging parties and competition authorities, and therefore, in turn, to consumers) from communication and cooperation between the competition authorities that have jurisdiction to investigate the merger.
- 16.2 In practice, communication and cooperation between competition authorities in such circumstances typically relates to the substantive assessment of the merger (eg through the sharing of evidence and analysis), any remedies that might be put in place to address competition concerns (eg to ensure that potential remedies in different jurisdictions are consistent, or at least mutually compatible, while meeting the applicable statutory requirements), and procedural matters (eg discussing alignment of case timelines).
- 16.3 In carrying out its merger investigations, the CMA frequently cooperates with other competition authorities. More broadly, the CMA actively seeks to promote best practice in merger control through networks such as the International Competition Network (ICN) and the Competition Committee of the Organisation for Economic Co-operation and Development (OECD). In addition, foreign authorities can request investigative assistance from the CMA in respect of their merger review functions.<sup>388</sup>
- 16.4 In relation to multi-jurisdictional mergers, communication and cooperation between competition authorities typically takes place within formal multilateral or bilateral arrangements or through the use of waivers. The CMA will, as standard, ask merger parties whether they have also notified or intend to notify the merger to other competition authorities and it will seek waivers to enable it to share information with those other agencies (and may also ask third parties to provide waivers). Once appropriate waivers<sup>389</sup> are received, the CMA will typically contact the relevant officials at the other competition authorities to discuss and share information on the merger as appropriate. In the event that parties do not provide confidentiality waivers, the CMA may be able to rely on other information gateways under [Part 9](#) of the Act to share specified information with relevant competition authorities.

---

<sup>388</sup> Sections 303 et seq. of the DMCC Act. For more details on investigative assistance please see guidance on *Transparency and disclosure: Statement of the CMA’s policy and approach* (CMA6).

<sup>389</sup> The CMA expects parties to provide waivers in the CMA standard template form. The CMA’s template waiver is available at: [Confidentiality waiver template - GOV.UK \(www.gov.uk\)](#).

- 16.5 Multi-jurisdictional mergers, being subject to different merger control requirements across multiple jurisdictions (and processes that have different timelines), can raise several additional considerations that the CMA, and merger parties, may seek to reflect in the CMA's approach to those mergers. In some circumstances, it may be beneficial for the CMA, in executing its duties under the Act, to be able to communicate and coordinate extensively with other authorities in reaching decisions on the competition assessment and remedies. There may also be circumstances in which it is appropriate for the CMA to take account of developments in other jurisdictions in assessing what action the CMA is required to take in relation to a given merger.
- 16.6 Merger parties are encouraged to discuss the process and timing of the review of a multi-jurisdictional merger with the CMA at an early stage (and to provide confidentiality waivers expediently to facilitate early-stage discussions with other competition authorities). This may, in some cases, include discussing with the CMA the timing of any pre-notification discussions and the commencement of formal proceedings before the CMA and/or other competition authorities to ensure, so far as possible, the alignment of the respective timetables.
- 16.7 In addition, the following aspects of this guidance may be particularly relevant in multi-jurisdictional mergers:
- (a) As noted in paragraph 8.3 above, the CMA might decide not to open an investigation immediately where a transaction is subject to review by a competition authority outside the UK and any remedies imposed or agreed in those proceedings would be likely to address any competition concerns that could arise in the UK. This could be the case, for example, where all of the markets that are relevant to the transaction are broader than national in scope. In this circumstance, merger parties may be invited to update the CMA on the progress of proceedings in other jurisdictions and to provide waivers to the CMA to discuss these proceedings with other competition authorities. The CMA may consider whether to open a formal investigation at any point before expiry of the four-month statutory period and merger parties run the risk that remedies in other jurisdictions that would not fully eliminate any competition concerns relating to the UK would result in the CMA opening a formal investigation at a later stage.
  - (b) As noted in paragraph 1.6 above, the CMA will generally apply this guidance flexibly and may depart from the approach described in the guidance where there is an appropriate and reasonable justification for doing so, which may include the alignment of the CMA's investigation with the processes of other competition authorities. Merger parties may wish to give early consideration to the potential process variations set out in this guidance where that might

help to support alignment between the processes in different competition authorities in multi-jurisdictional mergers.<sup>390</sup>

- (c) For example, as noted in paragraph 7.2 above, merger parties are able to request that a case should be 'fast tracked' to the consideration of UILs or to an in-depth phase 2 investigation. In some circumstances, this may aid the alignment of the CMA's substantive assessment and/or remedies process with proceedings in other jurisdictions.
- (d) Moreover, as noted in paragraph 7.27 above, merger parties are, in a phase 2 investigation, able to request that they formally accept that the CMA has evidence that establishes, to the required legal standard, that the relevant merger situation has resulted, or may be expected to result, in an SLC within a specified market or markets for goods or services in the UK. In some circumstances, the 'concession' of an SLC (which might involve business activities that may be within the scope of remedies being put in place in other jurisdictions) may aid the alignment of the CMA's remedies process with proceedings in other jurisdictions.
- (e) As noted in paragraph 9.74 above, the fact that competition authorities are considering a merger that the CMA is also investigating is one of the circumstances in which the CMA decision maker at phase 1 (or the Inquiry Group, at phase 2) may choose to become involved in remedies discussions before the SLC decision. The merger parties will be informed if the decision maker deems that this is appropriate. The merger parties are also able to request that the decision maker should become involved in remedies discussions before any SLC decision.
- (f) As noted in paragraph 11.70 above, the CMA and merger parties can agree to extend the inquiry period by a specific period. This provision may facilitate the alignment of the CMA's review with proceedings in other jurisdictions.

---

<sup>390</sup> See, for example, CMA Decision: Anticipated acquisition by Stryker Corporation of Wright Medical Group N.V. (30 June 2020).

## 17. Communication and publication of decisions, undertakings and orders

### General approach to publication

- 17.1 The CMA is mindful of the need to respect the confidentiality of commercially-sensitive information provided to it (by the merger parties and third parties). At the same time, it is required by [section 107](#) of the Act to publish its decisions and the reasons for them. Accordingly, in determining whether to excise information on the basis of confidentiality from the public version of its report, it will seek to ensure that the broad reasoning and the outcome of a decision remain clear. Therefore, when parties make requests for excision of confidential information, they are expected to justify each of those requests. The CMA will not accept blanket claims that particular classes of information are confidential.
- 17.2 In the event of a disagreement with the CMA as to the confidentiality of specific information relating to a party that the CMA proposes to publish in its decision, parties should seek in the first instance to resolve the matter with the CMA case team.<sup>391</sup> If, thereafter, the parties' concerns remain unresolved, they may make representations to the CMA's Procedural Officer, who will consider those representations and reach a determination on the issue in relation to a phase 1 inquiry or provide advice to the Inquiry Group in relation to a phase 2 inquiry who will make the final decision.<sup>392</sup>

### Phase 1

- 17.3 [Section 34ZA\(1\)\(b\)](#) of the Act requires the CMA to provide the merger parties with the reasons for its decision whether its duty to refer applies.<sup>393</sup> [Section 107](#) of the Act requires the CMA to publish its decisions, including decisions that a transaction is not a relevant merger situation and decisions not to refer (including findings that the market is of insufficient importance to justify a reference). However, this publication obligation does not apply to decisions where the CMA decides not to make a reference because it believes that the arrangements

---

<sup>391</sup> If the matter in disagreement arises in relation to a phase 2 inquiry the case team will liaise with the Inquiry Group as necessary.

<sup>392</sup> The Procedural Officer is intended to provide a swift, efficient supplementary mechanism for resolving disputes relating to the confidentiality of information proposed to be published by the CMA. See: [Procedural Officer: raising procedural issues in CMA cases - GOV.UK \(www.gov.uk\)](#).

<sup>393</sup> This does not apply to reference decisions made in the context of the statutory fast track process (see paragraph 7.24 above and section 107(6) of the Act (as amended by the DMCC Act).

concerned are not sufficiently far advanced, or are not sufficiently likely to proceed, to justify the making of a reference.<sup>394</sup>

- 17.4 Where the CMA finds that its duty to refer applies, and considers that there are reasonable grounds for believing that any UILs offered by the merger parties (or a modified version of them) might be accepted by the CMA, it will also publish a notice of that decision.<sup>395</sup>
- 17.5 On the day that the decision is finalised and adopted, the outcome of the CMA's decision is communicated to the merger parties and announced publicly. For cases in which the CMA has decided, on the information currently available to it, that it is or may be the case that the merger may be expected to result in an SLC within a market or markets in the UK and will be referred for a phase 2 investigation unless the merger parties offer acceptable UILs to address these competition concerns, it will publish a short summary of its findings in relation to its decision and may also issue a press release. The text of the reasoned decision is provided to the merger parties and subsequently published on [Competition and Markets Authority cases and projects - GOV.UK \(www.gov.uk\)](http://www.gov.uk) following the excision of confidential information (see paragraph 17.6 below).
- 17.6 Publication is generally a two-step process:
- (a) The first step is the announcement of the nature of the CMA's decision, done through the Regulatory News Service and placed on [Competition and Markets Authority cases and projects - GOV.UK \(www.gov.uk\)](http://www.gov.uk). Before publicly announcing the decision, the CMA will seek to notify the merger parties of the precise timing and nature of the decision. The exact timing of this communication will vary from case-to-case but typically the timing of this communication may be the day before, or on the same day as, the date of the announcement.<sup>396</sup> Where a press release is issued and a summary of the decision is published at the same time as announcement of the decision, these documents will also normally be sent to the merger parties at the

---

<sup>394</sup> ie decisions under section 33(2)(b) of the Act; see [section 107\(1\)\(aa\)](#).

<sup>395</sup> The final decision on whether to accept the UILs would be made following further consideration and public consultation – see [Merger Remedies Guidance \(CMA87\)](#).

<sup>396</sup> In cases where one or more of the merger parties is a UK-listed company, the CMA will contact the merger parties/their advisers after the London Stock Exchange has closed on the day before publication, normally after 5.00pm. By 7.00am (when the London Stock Exchange opens) the following day, the decision will be announced (and any press release/summary of the decision will be published) on [Competition and Markets Authority - GOV.UK \(www.gov.uk\)](http://www.gov.uk). Where the merger parties are listed companies in other jurisdictions, the CMA will, where possible, seek to avoid announcing its decision during stock exchange hours in those jurisdictions.

same time.<sup>397,398</sup> The purpose of sending these documents to the merger parties/their advisers is solely to identify, ahead of publication, any information which may be protected by Part 9 of the Act (see paragraphs 17.38 to 17.40 below). On the day the CMA announces its decision, it will also provide the merger parties with the text of its decision, having redacted any information which may relate to a third party.

- (b) The second step, usually sometime later, is the publication of the non-confidential text of the decision or notice on [Competition and Markets Authority cases and projects - GOV.UK \(www.gov.uk\)](https://www.gov.uk), which will be announced on the Regulatory News Service, following engagement with the merger parties and any third parties to identify any information which may be protected by [Part 9](#) of the Act. As the phase 1 decision provides the basis on which the merger parties and other interested parties will make initial submissions to the Inquiry Group as part of the phase 2 process, the CMA will seek to publish its phase 1 decisions expeditiously. As a result, it is important that merger parties comply with any deadlines set by the CMA to provide comments on the confidentiality of material in the decision. As noted above, in the event of a disagreement on the treatment of purportedly confidential information, merger parties may make representations to the CMA's Procedural Officer for formal adjudication.<sup>399</sup> The Procedural Officer will consider representations from both the merger parties and the case team before making a decision.

## **Phase 2**

### *Submissions*

17.7 The CMA generally publishes written submissions it receives at key stages of phase 2 investigations, in particular those received in response to the phase 1 decision, interim report and any invitation to comment on remedies. Parties

---

<sup>397</sup> Before prior notice of any announcement is given to the merger parties, an email will be sent to the merger parties or their advisers that sets out the terms on which any price-sensitive information is being provided. The merger parties must agree to these terms before the price-sensitive information will be provided. The same terms regarding price-sensitive information will also apply in the event that the case is referred for a phase 2 investigation.

<sup>398</sup> In some circumstances, the CMA may consider it is inappropriate to provide advance copies of any or some of the documents to the merger parties and/or their external advisers. For example, where the CMA has concerns as to the ability of merger parties and/or their external advisers to keep the contents of documents confidential before publication; or where there are issues of confidentiality which cannot be sufficiently protected under the terms of any embargo.

<sup>399</sup> The Procedural Officer is intended to provide a swift, efficient supplementary mechanism for resolving disputes relating to the confidentiality of information proposed to be published by the CMA. See: [Procedural Officer: raising procedural issues in CMA cases - GOV.UK \(www.gov.uk\)](https://www.gov.uk).

should provide non-confidential versions of submissions for publication at the same time as their full submissions. If this is not possible, parties should submit a non-confidential version as soon as possible and agree a timeframe with the case team (which will typically be no more than five working days from the date that the full submission was provided).

- 17.8 The non-confidential version of the submission must set out the fundamentals of the relevant party's case, with a sufficient description of the evidence relied upon to enable other parties to understand and, if appropriate, make representations in relation to the inferences drawn from this evidence. Requests for confidential treatment of information should be limited to information that is genuinely sensitive, the disclosure or publication of which would be likely to cause significant harm to a party's legitimate business interests or to the interests of any individual to whom the information relates.<sup>400</sup> Parties should therefore accompany the non-confidential version with a detailed explanation of why they consider that particular parts of their submissions should not be disclosed, including explaining the nature of the information, the harm that could be caused, and the likelihood and magnitude of that harm. Where appropriate, it should also identify information which may be confidential as between the merger parties – for example, where external advisers have combined confidential information from both merger parties.
- 17.9 The final decision on disclosure generally lies with the Inquiry Group, having regard to the CMA's powers and duties under the Act.<sup>401</sup> The publication of a non-confidential version of a party's submission should not be taken to mean that the CMA necessarily accepts that all the material excised in that version of the document should not be published or disclosed at some future stage of the inquiry, if such disclosure becomes necessary to fulfil the CMA's functions under the Act.<sup>402</sup>
- 17.10 In practice, it may be possible to avoid disclosure of sensitive information by, for example, publishing an anonymous version of the submission or publishing the

---

<sup>400</sup> [Section 244](#) of the Act.

<sup>401</sup> As described in this guidance, as well as in [Transparency and disclosure: Statement of the CMA's policy and approach \(CMA6\)](#) and [Chairman's Guidance on Disclosure of Information in Merger Inquiries, Market Investigations and Reviews of Undertakings and Orders accepted or made under the Enterprise Act 2002 and Fair Trading Act 1973 \(CC7 \(Revised\)\)](#).

<sup>402</sup> Parties will be informed of any decision to publish previously excised material that remains unpublished and given an opportunity to make representations.

confidential information in a way that mitigates the sensitivity of this information, for example replacing specific figures with ranges.<sup>403</sup>

17.11 In the event of a disagreement on the treatment of purportedly confidential information with the Inquiry Group, parties may make representations to the CMA's Procedural Officer within one working day (at least 24 hours, not counting weekends or public holidays) of the Inquiry Group's decision. The Procedural Officer will advise the Inquiry Group following consideration of the parties' representations.<sup>404</sup> The Inquiry Group will have all due regard to that advice, but the final decision remains with the Inquiry Group.

### *Interim report*

17.12 The CMA has a statutory duty to consult any relevant party whose interests are likely to be adversely affected by the CMA's proposed decision on the outcome of a merger and to give reasons for that proposed decision.<sup>405</sup> Consistent with settled precedent,<sup>406</sup> the interim report is the means by which the CMA fulfils this duty,<sup>407</sup> enabling merger parties to have an opportunity to respond to, challenge, and correct<sup>408</sup> the CMA.

17.13 However, the Act also imposes a general restriction on the disclosure of 'specified information'; that is, information the CMA receives during the course of

---

<sup>403</sup> For further information on the CMA's approach to disclosure see paragraphs 17.18 to 17.24 below. As set out in more detail below, certain information redacted from public versions of submissions may be disclosed into a confidentiality ring.

<sup>404</sup> The Procedural Officer is intended to provide a swift, efficient supplementary mechanism for resolving disputes relating to the confidentiality of information proposed to be published by the CMA. The procedure followed by the Procedural Officer in this regard will be flexible, and will be tailored to the nature of the dispute at hand and, in particular, to any specific timing constraints to which the CMA's investigation is subject. See: [Procedural Officer: raising procedural issues in CMA cases - GOV.UK \(www.gov.uk\)](https://www.gov.uk/guidance/raising-procedural-issues-in-cma-cases).

<sup>405</sup> Section 104 of the Act. 'Relevant party' is defined as meaning any person who appears to the relevant authority to control enterprises which are the subject of the reference or possible reference concerned.

<sup>406</sup> *Tobii AB (Pulb) v CMA* [2020] CAT 1, at paragraph 117; *Ryanair v Competition Commission* [2014] CAT 3, at paragraph 128; *BMI Healthcare Limited v Competition Commission* [2013] CAT 24, at paragraph 20; *Meta Platforms, Inc. v Competition and Markets Authority* [2022] CAT 26, at paragraph 157).

<sup>407</sup> [Chairman's Guidance on Disclosure of Information in Merger Inquiries, Market Investigations and Reviews of Undertakings and Orders accepted or made under the Enterprise Act 2002 and Fair Trading Act 1973 \(CC7 \(Revised\)\)](#), paragraph 7.1. The CMA's interim report was formerly named a 'provisional findings report', and is referred to as such in case law. While the name of the report has changed, the interim report fulfils the role previously played by the provisional findings, and the CMA therefore considers that the precedent case law continues to apply.

<sup>408</sup> *Ryanair v Competition Commission* [2014] CAT 3, at paragraph 133.



a merger inquiry which relates to the affairs of an individual or business of an undertaking.<sup>409</sup>

- 17.14 Both of these duties are qualified under the Act. The CMA's obligation to consult is subject to any need to keep what is proposed, or the reasons for it, confidential,<sup>410</sup> while the obligation to keep confidential specified information can be overridden for the purpose of facilitating the exercise by the CMA of its functions under the Act.<sup>411</sup> In balancing these potentially conflicting obligations, the CMA must ensure that it discloses confidential specified information<sup>412</sup> only insofar as it is necessary to do so.<sup>413</sup>
- 17.15 In accordance with settled precedent, the disclosure of confidential information will be deemed necessary where it forms part of the 'gist of the case' the merger parties have to answer.<sup>414</sup> In other words, the merger parties need to be provided with sufficient information in order to be able to make informed submissions in response to the CMA's interim report.
- 17.16 What constitutes the 'gist' of a case is context-sensitive.<sup>415</sup> In most cases, the 'gist' of the case will be provided in the interim report.
- 17.17 There is therefore no general right of 'access to file' within CMA merger control proceedings,<sup>416</sup> and the CMA is not, as a general principle, obliged to disclose all inculpatory or exculpatory material.<sup>417</sup>

#### *Additional disclosure*

- 17.18 Where the CMA considers that it must disclose highly confidential third-party information as part of the gist of the case, for example because it is included as part of the reasoning in the interim report, it may choose to impose additional

---

<sup>409</sup> Sections 237 and 238 of the Act. The CMA also notes that section 104 of the Act refers to the need to protect confidentiality.

<sup>410</sup> Section 104(4)(b) of the Act. It is also qualified by the practical restrictions imposed by the CMA's investigation timetable (under section 104(4)(a) of the Act).

<sup>411</sup> Section 241 of the Act. Other gateways are set out in sections 239 to 244 of the Act.

<sup>412</sup> That is, commercial information whose disclosure the CMA thinks might significantly harm the legitimate business interests of an undertaking or information relating to the private affairs of an individual whose disclosure the CMA thinks might significantly harm the individual's interests.

<sup>413</sup> Section 244 of the Act.

<sup>414</sup> *R v Secretary of State for the Home Department, Ex parte Doody* [1993] UKHL 8, page 14.

<sup>415</sup> *BMI Healthcare Ltd v. Competition Commission* [2013] CAT 24 at paragraph 39(7). See also *Meta Platforms Inc v CMA* [2022] CAT 26 at paragraph 148.

<sup>416</sup> *BMI Healthcare Ltd v. Competition Commission* [2013] CAT 24 at paragraph 4.

<sup>417</sup> *Groupe Eurotunnel SA v Competition Commission* [2013] CAT 30 at paragraph 221. See also *C r lia Group Holding SAS and C r lia UK Limited v Competition and Markets Authority* [2023] CAT 54.

safeguards to the disclosure of such information, most commonly by disclosing the information into a confidentiality ring (or disclosure room).

- 17.19 Confidentiality rings and disclosure rooms provide access to confidential information held by the CMA in a restricted manner. They limit the number and/or category of persons having access (and the use of the information being accessed). Strict rules relating to access and onward disclosure will be applied and recipients will be required to acknowledge that they understand the basis on which such disclosure is made and that they will comply with these restrictions.<sup>418</sup>
- 17.20 As described above, in determining the extent of disclosure of the interim report to the merger parties and their advisers, including through the use of confidentiality rings, the CMA is required to balance the degree of sensitivity of the information concerned against the necessity to make that disclosure to allow the merger parties to understand the gist of the case.<sup>419</sup> As a minimum, the CMA will make available a fully unredacted version of the interim report to a limited number of the merger parties' external legal (and, where appropriate, economic) advisers in a confidentiality ring,<sup>420</sup> but as part of this balancing exercise will also consider whether individuals from the merger parties themselves should be included within the confidentiality ring. The CMA will exercise its discretion as to whether individuals from the merger parties are included in the confidentiality ring having regard to the complexity of the market, the sensitivity of the information and the risks of breach associated with their inclusion.
- 17.21 The necessity aspect of the balancing exercise will consider, in particular, the extent to which external advisers can: either (a) make proper and informed submissions on the relevant material themselves; and insofar as necessary, (b) brief merging parties using non-confidential summaries or ask targeted questions to gather any extra information required without disclosing the underlying third-party confidential information, in order for merging parties to make proper and informed submissions on this material.
- 17.22 Disclosure within a confidentiality ring is subject to the relevant firms and individuals providing signed undertakings to the CMA for access to the confidentiality ring, in line with the CMA's template.<sup>421</sup> Breaching the terms of the confidentiality ring or data room carries serious consequences and may result in

---

<sup>418</sup> The CMA has published: [Confidentiality ring and disclosure room undertakings templates - GOV.UK \(www.gov.uk\)](https://www.gov.uk).

<sup>419</sup> *Meta Platforms Inc v CMA* [2022] CAT 26, paragraph 157(8).

<sup>420</sup> *Meta Platforms Inc v CMA* [2022] CAT 26, paragraph 157(12) and 159(3).

<sup>421</sup> [Confidentiality ring and disclosure room undertakings templates - GOV.UK \(www.gov.uk\)](https://www.gov.uk).

criminal penalties (up to two years imprisonment and/or a fine with no upper limit),<sup>422</sup> referral of the advisers to their professional regulator for disciplinary action, and potential exclusion from the current data room and any future CMA data access.

17.23 The CMA will endeavour to engage in advance with other parties (including third parties where relevant) prior to disclosing information in this way. The CMA may also anonymise and/or aggregate information and take any other steps it considers are reasonable in relation to the disclosed information.

17.24 The disclosure of information into a confidentiality ring or data room to the merger parties' external advisers remains subject to [Part 9](#) of the Act. The CMA will at all times seek to uphold its duty of maintaining confidentiality where possible, and the possibility of using a confidentiality ring or disclosure room to share confidential information will not result in the disclosure of confidential information beyond that necessary to provide the 'gist' of the case.

#### *Process for publishing interim report*

17.25 In advance of publishing the interim report, and on an embargoed basis, the CMA will seek to notify the merger parties of the process for publication and the precise timings. The exact timing of this communication will vary from case-to-case but will typically be no more than one week in advance.

17.26 The CMA's usual practice is to provide to the merger parties, by way of their external legal advisers<sup>423</sup> the following materials shortly before publication: a copy of the CMA's press release; the summary of interim report; and, where relevant, the Invitation to Comment on Remedies. These are finalised documents that are provided on an embargoed basis until publication solely to enable the merger parties to identify any information which may be protected under Part 9 of the Act and to prepare their external and/or internal communications. The merger parties are therefore not invited to make submissions on the substantive content of these embargoed documents.<sup>424</sup>

---

<sup>422</sup> A breach of [Part 9](#) of the Act constitutes a criminal offence under [section 245](#) of the Act.

<sup>423</sup> As noted above, there may be circumstances in which the CMA considers it is inappropriate to provide advance copies of any or some of the documents to the merger parties and/or their external advisers.

<sup>424</sup> In cases where one or more of the merger parties is a UK-listed company, the CMA's press release; the summary of interim report; and, where relevant, the Invitation to Comment on Remedies are made available to the merger parties on an embargoed basis after the London Stock Exchange has closed on the day before publication, normally after 5.00pm. The opportunity to make final representations on the CMA's treatment of information which may be protected under Part 9 of the Act will be brief and, in most cases, be as short as only a few hours (given the CMA will

- 17.27 At around the same time (or shortly thereafter), the redacted version of the full interim report is provided to the merger parties. This is provided on an embargoed basis until publication solely to enable the merger parties' external legal advisers to identify any information which may be protected under Part 9 of the Act. The merger parties' external legal advisers are not invited to make submissions on the substantive content of this embargoed document.<sup>425</sup>
- 17.28 As noted above, if the merger parties submit a Phase 2 Remedies Form, this should include a non-confidential summary of their remedy proposal for publication on the CMA's case page, as part of the Invitation to Comment on Remedies (if necessary).
- 17.29 To the extent there are any confidentiality redactions in the interim report, or the Invitation to Comment on Remedies, the CMA will also, as a minimum, make available a fully unredacted version to a limited number of the merger parties' external legal (and, where appropriate, economic) advisers in a confidentiality ring, but upon request will also consider on a case by case basis whether individuals from the merger parties should be included within the confidentiality ring, in each case subject to appropriate safeguards.

#### *Interim report on remedies*

- 17.30 The interim report on remedies is not published. If however the CMA deems wider consultation on the interim report on remedies to be necessary, the CMA will follow the same process as set out above in relation to other published documents.
- 17.31 As with the interim report, to the extent there are any confidentiality redactions in the interim report on remedies, the CMA will also, as a minimum, make available a fully unredacted version of the interim report on remedies to a limited number of the merger parties' external legal (and, where appropriate, economic) advisers in a confidentiality ring, but will also consider whether individuals from the

---

have taken steps earlier in the process to identify any confidential material). By 7.00am (when the London Stock Exchange opens) the following day, these documents are published on [Competition and Markets Authority - GOV.UK \(www.gov.uk\)](http://www.gov.uk). Where the merger parties are listed companies in other jurisdictions, the CMA will, where possible, seek to avoid announcing its decision during stock exchange hours in those jurisdictions.

<sup>425</sup> The opportunity to make final representations on the CMA's treatment of information which may be protected under [Part 9](#) of the Act will be brief and, in most cases, by no later than 12.00pm the following day. By 4.00pm this document is published on [Competition and Markets Authority - GOV.UK \(www.gov.uk\)](http://www.gov.uk). If the CMA is fully satisfied that all confidential material has been treated appropriately within the interim report, it may set the deadline for final representations on the CMA's treatment of information which may be protected under [Part 9](#) of the Act, and publish the full report at the same time as the CMA's press release; the summary of interim report; and, where relevant, the Invitation to Comment on Remedies.

merger parties should be included within the confidentiality ring, in each case subject to appropriate safeguards.

### *Final report*

- 17.32 Similar to the process at the interim report stage, in advance of publishing the final report (which, for cases that the CMA concludes that the Merger would give rise to an SLC, will include the CMA's final decision on remedies), and on an embargoed basis, the CMA will seek to notify the merger parties of the process for publication and the precise timings. The exact timing of this communication will vary from case-to-case but will typically be no more than one week in advance.
- 17.33 The CMA's usual practice is to provide to the merger parties, by way of their external legal advisers<sup>426</sup> the following materials before publication: a copy of the CMA's press release; and the summary of the final report. These are finalised documents that are provided on an embargoed basis until publication solely to enable the merger parties to identify any information which may be protected under [Part 9](#) of the Act and to prepare their external and/or internal communications.<sup>427</sup>
- 17.34 At around the same time (or shortly thereafter), the redacted version of the full final report is provided to the merger parties external legal advisers only. This is provided on an embargoed basis until publication solely to enable the merger parties' external legal advisers to identify any information which may be protected under [Part 9](#) of the Act.<sup>428</sup>

---

<sup>426</sup> As noted above, there may be circumstances in which the CMA considers it is inappropriate to provide advance copies of any or some of the documents to the merger parties and/or their external advisers.

<sup>427</sup> In cases where one or more of the merger parties is a UK-listed company, the CMA's press release and the summary of the final report are made available to the merger parties on an embargoed basis after the London Stock Exchange has closed on the day before publication, normally after 5.00pm. The opportunity to make final representations on the CMA's treatment of information which may be protected under [Part 9](#) of the Act will be brief and, in most cases, be as short as only a few hours (given the CMA will have taken steps earlier in the process to identify any confidential material). By 7.00am (when the London Stock Exchange opens) the following day, these documents are published on [Competition and Markets Authority - GOV.UK \(www.gov.uk\)](#). Where the merger parties are listed companies in other jurisdictions, the CMA will, where possible, seek to avoid announcing its decision during stock exchange hours in those jurisdictions.

<sup>428</sup> The opportunity to make final representations on the CMA's treatment of information which may be protected under [Part 9](#) of the Act will be brief and, in most cases, by no later than 12pm the following day. By 4pm this document is published on [Competition and Markets Authority - GOV.UK \(www.gov.uk\)](#). If the CMA is fully satisfied that all confidential material has been treated appropriately within the final report because most excision requests will have been resolved ahead of publication of the interim report or through a 'put-back' process of any additional submissions/evidence prior to production of the final report, it may set the deadline for final representations on the

17.35 As with the interim report, to the extent there are any confidentiality redactions in the Final Report, the CMA will also, as a minimum, make available a fully unredacted version of the Interim Report to a limited number of the merger parties' external legal (and, where appropriate, economic) advisers in a confidentiality ring, but will also consider whether individuals from the merger parties should be included within the confidentiality ring, in each case subject to appropriate safeguards.

## Publication of undertakings and orders

17.36 The CMA publishes the details of all merger undertakings and orders that have been agreed and accepted or imposed under the Act on the relevant case page.<sup>429</sup> Publication is designed to ensure that interested third parties are aware of the undertakings and, in the event of a breach of undertakings, they may take action in the courts under [section 94](#) of the Act.

17.37 Once they are in place, undertakings and orders are monitored by the CMA under [section 92](#) of the Act in order to ensure compliance and so that the CMA may consider whether they should be amended or replaced, or, where relevant, so that the CMA may advise the Secretary of State as to such issues (see [Remedies: Guidance on the CMA's approach to the variation and termination of merger, monopoly and market undertakings and orders \(CMA11\)](#)). Any changes that are agreed are published in the same way as the original undertakings and orders.

## Freedom of Information Act

17.38 The Freedom of Information Act 2000 (the FOIA) creates a general right of access to information held by public bodies, including the CMA.<sup>430</sup> A request for information under the FOIA will be dealt with within 20 working days of receipt.

17.39 There are a number of exemptions from disclosure under the FOIA of potential relevance to a request for information held by the CMA, including where disclosure would be prohibited under any statutory bar to disclosure including

---

CMA's treatment of information which may be protected under Part 9 of the Act, and publish the full report at the same time as the CMA's press release and summary of the final report.

<sup>429</sup> See: [Competition and Markets Authority cases and projects - GOV.UK \(www.gov.uk\)](#). The CMA is also required by [section 107](#) of the Act to publish any IEO or interim order made by it under [section 72](#) or [76](#) of, or paragraph 2 of [Schedule 7](#) to, the Act.

<sup>430</sup> More information on the FOIA can be found at [Competition and Markets Authority - GOV.UK \(www.gov.uk\)](#), including contact details should you require further information. More detailed information on the FOIA is available on the Information Commissioner's website at [Information Commissioner's Office \(ICO\)](#).

under the Act.<sup>431</sup> [Part 9](#) of the Act, under which information relating to the affairs of an individual (a sole trader, for example) or any business of an undertaking which has come to the CMA may not be disclosed during the lifetime of the individual or while the undertaking continues in existence unless the disclosure is permitted under one of the gateways in the Act, therefore continues to apply. In addition, the CMA may rely on [section 31\(1\)\(g\)](#) of the FOIA (for the purposes at [section 31\(2\)](#)) in withholding information if it considers its disclosure would, or would be likely to, prejudice the exercise by the CMA of its statutory merger control functions and there are public interest arguments for maintaining the exemption outweighing the public interest in disclosing the information. Other exemptions may also be engaged, depending on the facts.

17.40 Further information on exchanges of confidential information in the context of multi-jurisdictional mergers is provided in chapter 16 above.

## **Data Protection – UK General Data Protection Regulation (EU) 2016/679 and Data Protection Act 2018**

17.41 The CMA is a ‘controller’ under data protection law. Data Protection law is set out in the UK General Data Protection Regulation (GDPR)<sup>432</sup> and in the Data Protection Act 2018. Where the CMA processes personal data as part of, and in order to carry out, its statutory investigatory, regulatory and enforcement work, it does so in compliance with data protection law. In general terms, ‘personal data’ is information relating to a living individual who can be identified from it, either directly or indirectly.

17.42 For more information about how, and on what legal grounds, the CMA processes personal data; parties rights where the CMA is processing personal data about them, including parties’ right to complain to the Information Commissioner’s Office; and for more information about how to contact the CMA’s Data Protection Officer, who oversees all the CMA’s processing of personal data, see the CMA’s Privacy Notice: [Personal information charter - Competition and Markets Authority - GOV.UK \(www.gov.uk\)](#).

---

<sup>431</sup> [Section 44\(1\)\(a\)](#) of the FOIA.

<sup>432</sup> The UK GDPR refers to the EU GDPR ((EU) 2016/679, which has been adopted into UK law by the EU Withdrawal Act 2018, as amended by the Data Protection, Privacy and Electronic Communications (Amendments etc) (EU Exit) Regulations 2019.



## 18. Fees

- 18.1 Subject to some limited exceptions,<sup>433</sup> any merger that qualifies as a relevant merger situation (including on the 'may be the case' standard)<sup>434</sup> and in which the CMA (or Secretary of State in public interest cases) reaches a decision on whether or not to refer the merger for a phase 2 investigation, is subject to a fee irrespective of whether a reference is made.<sup>435</sup> That fee is collected by the CMA on behalf of HM Treasury. The main exception is where the interest acquired or being acquired is less than a controlling interest and a Merger Notice has not been submitted in relation to that acquisition.<sup>436</sup> In addition, there is an exemption from paying a fee where the acquirer and any group of which it is a member qualify as small or medium sized. This is defined by reference to qualifying conditions in the Companies Act 2006 (see paragraph 18.6 below).
- 18.2 Where a fee is due, that fee is payable by the person filing the Merger Notice, or – in cases in which no Merger Notice is filed – the person acquiring control. The fee becomes payable on the publication by the CMA of either a reference decision or any decision not to make a reference. No fee is payable if the CMA finds that the case does not qualify as a relevant merger situation. For cases resolved through UILs, the fee becomes payable when the CMA loses its duty to refer as a result of its formal acceptance of UILs. In the case of public interest cases decided by the Secretary of State, the fee becomes payable to the CMA when the Secretary of State publishes a reference decision under [section 45](#) of the Act or publishes any decision not to make such a reference. In all cases, an invoice will be issued by the CMA when the fee becomes payable. Payment must be made within 30 days of the date of the invoice.
- 18.3 Given that a fee is payable in all cases in which the CMA reaches a decision whether or not to refer in respect of a relevant merger situation, a fee will be payable in cases where the CMA decides to investigate the merger on its own

---

<sup>433</sup> A fee shall not be payable in relation to arrangements that are in progress or in contemplation which, if carried into effect, will result in the creation of a relevant merger situation, where the CMA decides pursuant to [section 33\(2\)\(b\)](#) of the Act that the arrangements concerned are not sufficiently far advanced, or are not sufficiently likely to proceed, to justify the making of a merger reference.

<sup>434</sup> This therefore excludes 'found-not-to-qualify' cases (where the transaction is found not to give rise to a relevant merger situation). In those cases, no fee is payable.

<sup>435</sup> Full details in respect of the payment of fees are, pursuant to [section 121](#) of the Act, set out in the Enterprise Act 2002 (Merger Fees and Determination of Turnover) Order 2003 SI 2003/1370 (as amended).

<sup>436</sup> Chapter 4 explains further the meaning of the term 'controlling interest'. It should be noted, however, that multiple parties may be treated as one person for the purposes of determining whether fees are payable, potentially as a result of the application of the 'associated persons' provision, in which case they are jointly and severally liable for the fee under Article 6(4) of the Enterprise Act 2002 (Merger Fees and Determination of Turnover) Order 2003 SI 2003/1370 (as amended).



initiative and proceeds to publish such a decision (save, as noted above, in cases where the interest acquired is less than a controlling interest).

- 18.4 Information on how to pay the fee (including the CMA's account details and the forms of payment that it will accept) is available on [Merger fees payment information - GOV.UK \(www.gov.uk\)](#).
- 18.5 Fees vary according to the type and size of the merger. Details of the current fee scales are available from the case team and on [Merger fees payment information - GOV.UK \(www.gov.uk\)](#).
- 18.6 Where the acquirer qualifies as small or medium sized as defined (by reference to provisions of the Companies Act 2006<sup>437</sup>) in the Enterprise Act 2002 (Merger Fees and Determination of Turnover) Order 2003 (as amended) it is exempt from paying the above fees.
- 18.7 Fees are payable on the making of a merger reference under the Water Industry Act 1991 (see chapter 15). In such cases, the level of the fee is determined depending on the value of the turnover of the water enterprise being acquired in England and Wales.<sup>438</sup>

---

<sup>437</sup> At the time of writing, 'small enterprises' under [section 382](#) of the Companies Act 2006 are those satisfying two or more of the following criteria: (i) turnover of not more than £10.2 million; (ii) balance sheet total of not more than £5.1 million; (iii) number of employees not more than 50. 'Medium enterprises' under [section 465](#) of the Companies Act 2006 are those satisfying two or more of the following criteria: (i) turnover of not more than £36 million; balance sheet total of not more than £18 million; (iii) number of employees of not more than 250. Full details are set out in [sections 382](#) and [465](#) of the Companies Act 2006, most recently amended by the Companies, Partnerships and Groups (Accounts and Reports) Regulations SI 2015/980. Where the acquirer is a member of a group as defined in [section 474](#) of the Companies Act 2006, it will qualify as small if the group qualifies as small under [section 383](#) of the Companies Act 2006, or medium sized if the group qualifies as medium-sized under [section 466](#) of the Companies Act 2006.

<sup>438</sup> The Enterprise Act 2002 (Merger Fees and Determination of Turnover) Order 2003 SI 2003/1370 (as amended).

## Appendix A: Guidance on the calculation of turnover for the purposes of Part 3 of the Act

1. This Appendix provides guidance on the calculation of turnover for the purposes of chapter 1 of [Part 3](#) of the Act.
2. While this Appendix is intended to help explain the detailed provisions of the law concerning turnover calculation, it should not be regarded as a substitute for the Act and secondary legislation made under it. Nor should it be regarded as a substitute for expert legal advice on the interpretation of the Act and secondary legislation.

### Background

3. Under the turnover test in the Act, a relevant merger situation will arise if two or more enterprises cease to be distinct and the turnover in the UK of the enterprise being taken over exceeds £100 million (see chapter 4 above).<sup>439</sup>
4. Under the safe harbour threshold, a relevant merger situation will not arise if none of the enterprises concerned has a UK turnover exceeding £10 million (see paragraphs 4.59 to 4.62 above).
5. Under the 'hybrid' jurisdictional test, a relevant merger situation will arise where the person(s) that carry on one of the enterprises concerned supply or acquire at least 33% of goods or services of any description in the UK (or a substantial part of the UK); the same enterprise concerned has a UK turnover exceeding £350 million; and any other enterprise concerned has a UK nexus (the 'hybrid test') (see paragraphs 4.72 to 4.91 above).
6. The turnover of the enterprise being taken over is, for the purposes of the turnover test and the safe harbour threshold, calculated by taking together the total value of the UK turnover of all the enterprises ceasing to be distinct and deducting either:
  - (a) the UK turnover of any enterprise which continues to be carried on under the same ownership and control, or

---

<sup>439</sup> [Section 23\(1\)\(b\)](#) of the Act.

- (b) if no enterprise continues to be carried on under the same ownership or control, the UK turnover of the enterprise whose turnover has the highest value.<sup>440</sup>
7. In most relevant merger situations, this means in practice that the applicable turnover for mergers within (a) above – which is most takeovers and acquisitions – will be the UK turnover of the target enterprise. For mergers falling within (b) above – a full legal merger or a joint venture combining all of the merger parties’ assets and businesses, for example – the applicable UK turnover will be that of the enterprise having the lower turnover (or, put another way, in this scenario both enterprises must have UK turnover exceeding £100 million or £10 million).
8. The method of calculating the applicable turnover is set out in the Enterprise Act 2002 (Merger Fees and Determination of Turnover) Order 2003 SI 2003/1370 (as amended) (referred to in this Appendix as ‘the Order’). This method applies for the purposes of calculating:
- (a) the turnover of the enterprise being acquired in the context of the turnover test;
  - (b) the turnover of the enterprise being taken over and the turnover of any other enterprise concerned in the context of the safe harbour threshold, and
  - (c) the turnover of the enterprise concerned in the context of the new hybrid test.

## **Period over which turnover is calculated**

9. The relevant period used for the purposes of determining turnover under [Part 3](#) of the Act is the business year preceding either the date the enterprises ceased to be distinct (in the case of a completed merger); or, the date of the CMA’s decision whether or not to make a reference (in the case of a proposed merger). However, in either case, the CMA may substitute such earlier date as it considers appropriate.<sup>441</sup> In practice, the CMA will usually consider the turnover for the last completed ‘business year’ preceding either the date the enterprises ceased to be distinct (for a completed merger) or the date of notification (in the case of a proposed merger).

---

<sup>440</sup> [Section 28\(1\)](#) of the Act.

<sup>441</sup> Article 10(2)(a) and (b) of the Order.

10. A 'business year' for these purposes is any period of more than six months for which accounts have been or will be prepared.<sup>442</sup> In general, this will, of course, be a 12-month period. Where (perhaps because the enterprise has been newly formed) there is a period for which there is no preceding business year then the applicable turnover is the turnover for that shorter period.<sup>443</sup>
11. If the preceding business year is not a period of 12 months, then turnover, for the purposes of chapter 1 of [Part 3](#) of the Act, is arrived at by adjusting the applicable turnover received in that period by the same proportion as 12 months bears to that period.<sup>444</sup> Thus, if the preceding business year for an enterprise ceasing to be distinct is a nine-month period during which the applicable turnover was £54 million, then turnover for this purpose (that is, for determining whether the jurisdictional threshold is met) would be £72 million (£54 million ÷ 9 × 12).
12. In determining the applicable turnover of an enterprise, the CMA may take into account events which have occurred since the end of the business year and which may have a significant impact on the turnover of the enterprise ceasing to be distinct.<sup>445</sup> This allows the CMA to take account of acquisitions or divestments or other transactions which have had, or will potentially have, a continuing positive or negative effect on the turnover of the enterprise. The CMA would only expect to exercise this discretion in cases where the effect may impact upon the question of jurisdiction or the fee due.

## Applicable turnover

13. The applicable turnover of an enterprise is the turnover of the enterprise arising during the previous business year. It comprises the amounts derived from the sale of products and the provision of services which it makes in the ordinary course of its business activities to customers (businesses or consumers) in the UK, net of any sales rebate, value added tax and other taxes directly related to that turnover.<sup>446</sup> The calculation of turnover for these purposes should be interpreted in accordance with accounting principles and practices that are generally accepted in the UK.<sup>447</sup> Turnover includes any aid granted by a public body to a business which is directly linked to the sale of products or the provision of services by the business and therefore reflected in the price of those

---

<sup>442</sup> Article 2(c) of the Order.

<sup>443</sup> Article 10(4) of the Order.

<sup>444</sup> Article 2(b) of the Order.

<sup>445</sup> Article 10(3) of the Order.

<sup>446</sup> Paragraph 3 of the Schedule to the Order.

<sup>447</sup> Paragraph 2 of the Schedule to the Order.

products/services.<sup>448</sup> Special provisions, described below, apply to an enterprise which is (in whole or in part) a credit institution, financial institution or insurance undertaking.

### **Credit institutions and financial institutions**

14. The applicable turnover of an enterprise which, in whole or in part, is a credit institution or financial institution is the sum of certain specified income received by the branch or division of that institution in the UK, after the deduction of value added tax and other taxes directly related to those items.<sup>449</sup> The types of income specified for these purposes are:
- (a) interest income and similar income;
  - (b) income from securities;
  - (c) income from shares and other variable yield securities;
  - (d) income from participating interests;
  - (e) income from shares in affiliated undertakings;
  - (f) commissions receivable;
  - (g) net profit on financial operations; and
  - (h) other operating income.

### **Credit institutions and financial institutions**

15. The applicable turnover of an enterprise which, in whole or in part, is an insurance undertaking is the value of the gross premiums received from residents of the UK after deduction of taxes and certain other premium-related deductions.<sup>450</sup> Gross premiums received comprises all amounts received together with all amounts receivable in respect of insurance contracts issued by or on behalf of an insurance undertaking, including outgoing reinsurance premiums.

---

<sup>448</sup> Paragraph 13 of the Schedule to the Order.

<sup>449</sup> Paragraphs 10 and 11 of the Schedule to the Order.

<sup>450</sup> Paragraphs 10 and 12 of the Schedule to the Order.

## Enterprises treated as under common ownership or control

16. Where an enterprise ceasing to be distinct consists of two or more enterprises which are under common ownership or common control the applicable turnover is calculated by adding together the applicable turnover of each of those enterprises.<sup>451</sup> For the purposes of determining whether enterprises are treated as being under common control when calculating the applicable turnover, the provisions of sections 26(2) and (3) (as reproduced in paragraphs 5 and 6 of the Schedule to the Order) and section 127 of the Act apply as they apply in the Act for the purposes of determining whether enterprises have ceased to be distinct.<sup>452</sup>
17. As a result, applicable turnover may include not only the applicable turnover of the particular enterprise ceasing to be distinct but also that of certain other enterprises to which it is 'linked'. In particular, this might include the applicable turnover of any enterprise over which the enterprise ceasing to be distinct has control for the purposes of section 26(3) (as reproduced at paragraph 6 of the Schedule) of the Act – that is where the interest held confers, at least, the ability materially to influence policy. Where applicable turnover includes the applicable turnover of a linked enterprise, in which the enterprise ceasing to be distinct has less than a controlling interest, the whole of the applicable turnover of the linked enterprise is included in assessing whether the jurisdictional tests are met. There is no reduction simply because the interest is less than a controlling interest.
18. For example:
  - (a) Company A acquires Company B and also its subsidiaries B1 and B2: B and B1 and B2 are enterprises of interconnected bodies corporate which are treated as being under common control and their turnover is taken together in arriving at the applicable turnover of the enterprises ceasing to be distinct.
  - (b) Company A acquires Company C which also has a significant shareholding – conferring at least material influence – in Company D. The turnover of Company C and Company D is taken together in determining the applicable turnover.
  - (c) Partnerships A, B and C act together to secure control of Partnership D and form Partnership E. Partnerships A, B and C are associated persons and their turnover is added together. To determine the applicable turnover, the

---

<sup>451</sup> Paragraph 4 of the Schedule to the Order. This principle does not apply in relation to the safe harbour threshold (see paragraph 4.62).

<sup>452</sup> Paragraphs 5, 6 and 7 of the Schedule to the Order.

higher of the two turnover figures (that is, of A, B and C together or of D) is deducted from the combined turnover figure (of A, B, C and D).

- (d) Company A and its subsidiaries A1 and A2 acquire company B. Company A and A1 and A2 are enterprises of interconnected bodies corporate which are treated as being under common control and their turnover is taken together in determining the relevant turnover.
  - (e) Company A, which has a shareholding conferring at least material influence in Company D, acquires Company B. The turnover of Company A and Company D may be taken together in determining the relevant turnover.
19. In the case of some joint ventures, none of the enterprises will remain under the same ownership or control. For example, Company A and Company B may form a 50:50 joint venture (Newco) incorporating all their assets and businesses. In this case, neither enterprise A or B will remain under the same ownership or control as previously. In determining the relevant applicable turnover, the highest turnover (of A or B) would therefore, effectively, be ignored. By contrast, where Company A and Company B form a joint venture incorporating their assets and businesses in a particular area of activity, each parent with control ceases to be distinct from the target business contributed to the joint venture by the other parent, but the parent companies themselves remain under the same ownership and control after the merger. Therefore, the parent companies have their turnover deducted and the relevant turnover is the sum of the turnover of each of the contributed enterprises.

## **Treatment of intra-group transactions**

20. To avoid double counting, applicable turnover does not include amounts that are derived from transactions involving the sale of goods or provision of services between enterprises that are and will remain, post-merger, under the same common ownership or common control.<sup>453</sup> In other words, external sales only are taken into account.
21. However, in certain cases the CMA may take into account sales that were previously internal to a group and may attribute an appropriate value to such sales. This is to allow the CMA to make a sensible assessment of the turnover for jurisdictional purposes of the business being sold.

---

<sup>453</sup> Paragraph 8 of the Schedule to the Order.

22. Where, as a result of the merger, one or more enterprises will cease to be under the same common ownership or common control – that is, where what was an intra-group transaction pre-merger would, post-merger, be regarded as an external transaction – then the CMA may treat the amounts derived from the previously internal transactions as applicable turnover. In these cases, if such transactions have not resulted in any turnover, or the CMA believes that the turnover attributed to them does not reflect open market value, then the CMA may attribute an appropriate value to those transactions for inclusion in the applicable turnover.<sup>454</sup>

**Example:** The enterprise ceasing to be distinct is part of a vertically integrated process, a mill supplying flour to a downstream baking operation. It is possible that, pre-merger, the raw material (flour) may be supplied by the mill to the baking operation at a nil value or less than market price. If only the mill was being taken over, the turnover attributed to the milling operation may, as a result, be artificially low. In these circumstances the CMA might exercise its discretion to take into account the pre-merger supplies of raw materials (flour) to the baking operation in calculating the applicable turnover, and to attribute a more appropriate value for those supplies. In seeking to re-value the turnover attributed to the supply of such goods so that it more accurately reflects an open market value, the CMA might have regard to the terms of any future supply agreement that might be part of the transaction as well as market prices more generally. Again, it is likely that the CMA would only seek to exercise this discretion in those cases where the effect may impact upon the question of jurisdiction or the fee due.

## Treatment of foreign currencies

23. The turnover test is expressed in terms of pounds sterling. If it is necessary to convert foreign currencies in order to arrive at this figure then the CMA would usually be content to accept the approved exchange rate applicable at the date of the accounts.

---

<sup>454</sup> Paragraph 9 of the Schedule to the Order.



## Appendix B: Guidance and commentary in relation to the CMA's assessment of mergers

1. In addition to this guidance, the CMA (or its predecessor organisations) has published a number of other pieces of guidance and commentary in relation to the assessment of mergers, namely:
  - (a) *Merger assessment guidelines* (CMA129);
  - (b) *Suggested best practice for submission of technical economic analysis to the CC* (CC2com3);
  - (c) *Administrative penalties: Statement of Policy on the CMA's approach* (CMA4);
  - (d) *Transparency and disclosure: Statement of the CMA's policy and approach* (CMA6);
  - (e) *Chairman's guidance on disclosure of information in merger and market inquiries* (CC7) (Revised);
  - (f) *Remedies: Guidance on the CMA's approach to the variation and termination of merger, monopoly and market undertakings and orders* (CMA11);
  - (g) *Rules of procedure for merger, market and special reference groups* (CMA17);
  - (h) *Quick guide to UK merger assessment* (CMA18);
  - (i) *Water and sewerage mergers: Guidance on the CMA's procedure and assessment* (CMA49);
  - (j) *Guidance on the CMA's mergers intelligence function* (CMA56);
  - (k) *Retail mergers commentary* (CMA62);
  - (l) *Mergers: Exceptions to the duty to refer* (CMA64);
  - (m) *Rail franchise mergers: Review of methodologies and guidance* (CMA74con);
  - (n) *Good practice in the design and presentation of customer survey evidence in merger cases* (CMA78);

- (o) *Merger remedies (CMA87)*;
  - (p) *Guidance on requests for internal documents in merger investigations (CMA100)*;
  - (q) *Interim measures in merger investigations (CMA108)*;
  - (r) *Merger and market remedies – guidance on reporting, investigation and enforcement of potential breaches (CMA136revised)*;
  - (s) Energy network mergers Guidance on the CMA’s procedure and assessment (CMA190); and
  - (t) Guidance on the mergers reporting requirement for SMS firms (CMA 195).
2. Interested parties should refer to those documents listed above where relevant, subject in particular to the following general limitations:
- (a) all references to issues of jurisdiction or procedure in mergers cases must be read in the light of this guidance;
  - (b) in the case of conflict between this guidance and any other guidance produced or adopted by the CMA, the most recently published document takes precedence;
  - (c) the original text of any guidance issued by one of its predecessor organisations and adopted by the CMA (‘adopted guidance’) has been retained unamended: as such, that text does not reflect or take account of developments in case law, legislation or practice since its original publication; and
  - (d) all the adopted guidance should be read subject to the following cross-cutting amendments:
    - (i) references to the 'OFT' or 'CC' (except where referring to specific past OFT or CC practice or case law), should be read as referring to the CMA;
    - (ii) references to 'referral to the CC' or 'a reference to the CC' should be read as referring to the referral of a case by the CMA (or Secretary of State) of a case for a phase 2 investigation involving an Inquiry Group of CMA panel members;
    - (iii) certain OFT or CC departments, teams or individual roles may not be replicated in the CMA, or may have been renamed. A copy of the CMA's

organisational chart is available on [CMA structure - GOV.UK \(www.gov.uk\)](#); and

- (iv) parties should check any contact details against those listed on [Competition and Markets Authority - GOV.UK \(www.gov.uk\)](#), which will be the most up to date.

## Appendix C: Ancillary restraints

### Introduction

1. Mergers and ancillary restrictions to the merger are generally excluded from the prohibitions of the Competition Act 1998 (CA98), as amended by ERRA13, under [Schedule 1](#) of the CA98. This extends to any provision directly related and necessary to the implementation of the merger provisions (referred to in this guidance as ‘ancillary restraints’).<sup>455</sup>
2. The CMA considers that it is, in principle, no better placed than the merger parties and their advisers in most cases to determine whether contractual arrangements and agreements are ancillary to a merger and, therefore, automatically excluded from the Chapter I and Chapter II prohibitions of the CA98. Accordingly, the CMA will not ordinarily give a view in its published decision (or to the merger parties confidentially) on whether or not a restriction is ancillary.<sup>456</sup>
3. This Appendix sets out the CMA’s analytical approach to ancillary restraints. It sets out the principles for assessing whether, and to what extent, the most common types of agreements are considered to be ancillary restraints.

### General principles

4. The criteria of direct relation and necessity set out under [Schedule 1](#) of the CA98 are objective in nature. Restrictions are not directly related and necessary to the implementation of a merger simply because the merger parties regard them as such.
5. For restrictions to be considered ‘directly related to the implementation of the merger’, they must be closely linked to the merger itself. It is not sufficient that an agreement has been entered into in the same context or at the same time as the merger.<sup>457</sup> Restrictions which are directly related to the merger are economically

---

<sup>455</sup> [Schedule 1](#), section1(2), CA98.

<sup>456</sup> In exceptional cases raising novel or unresolved questions, the CMA may agree to provide guidance on the ancillary nature of a restriction. In these rare cases, the CMA may need to seek the views of third parties, and it will include its assessment of the restriction in its published decision on the merger. As a result, the CMA will not be able to express a view as to whether the restrictions are ancillary if the merger parties consider that the arrangements are confidential, or if there is insufficient time to consider these matters within the statutory deadlines of an investigation.

<sup>457</sup> Likewise, a restriction could, if all other requirements are fulfilled, be ‘directly related’ even if it has not been entered into at the same time as the agreement carrying out the main object of the merger.

related to the main transaction and intended to allow a smooth transition to the changed company structure after the merger.

6. Agreements must be 'necessary to the implementation of the merger provisions',<sup>458</sup> which means that, in the absence of those agreements, the merger could not be implemented or could only be implemented under considerably more uncertain conditions, at substantially higher cost, over an appreciably longer period or with considerably greater difficulty. Agreements necessary to the implementation of a merger are typically aimed at protecting the value transferred, maintaining the continuity of supply after the break-up of a former economic entity, or enabling the start-up of a new entity. In determining whether a restriction is necessary, it is appropriate not only to take account of its nature, but also to ensure that its duration, subject matter, and geographical field of application does not exceed what the implementation of the merger reasonably requires. If equally effective alternatives are available for attaining the legitimate aim pursued, the merger parties must choose the one which is objectively the least restrictive of competition.
7. For acquisitions which are carried out in stages, the contractual arrangements relating to the stages before the establishment of control<sup>459</sup> within the meaning of [section 26](#) of the Act cannot normally be considered directly related and necessary to the implementation of the merger. However, an agreement to abstain from material changes in the target's business until completion is considered directly related and necessary to the implementation of the merger.<sup>460</sup> The same applies, in the context of a joint bid, to an agreement by the joint purchasers of an enterprise to abstain from making separate competing offers for the same enterprise, or otherwise acquiring control.
8. Agreements which serve to facilitate the acquisition of any level of control over a target by more than one enterprise are to be considered directly related and necessary to the implementation of the merger. This will apply to arrangements between the merger parties for the acquisition of control aimed at implementing the division of assets in order to divide the production facilities or distribution networks among themselves, together with the existing trademarks of the acquired enterprise.

---

<sup>458</sup> [Schedule 1](#), section1(2), CA98.

<sup>459</sup> For the purposes of this Appendix, 'control' is defined as comprising any level of control set out under [section 26](#) of the Act, including material influence.

<sup>460</sup> The CMA may put in place interim measures to prevent the merger parties from giving effect to such ancillary restraints where the CMA considers it necessary to prevent or unwind pre-emptive action.

9. To the extent that such a division involves the break-up of a pre-existing economic entity, arrangements that make the break-up possible under reasonable conditions are to be considered directly related and necessary to the implementation of the merger, under the principles set out below.

### **Principles applicable to commonly encountered ancillary restraints in cases of acquisition of an enterprise**

10. Restrictions agreed between the merger parties in the context of a transfer of an enterprise may be to the benefit of the purchaser or of the seller. In general terms, the need for the purchaser to benefit from certain protection is more compelling than the corresponding need for the seller. It is the purchaser who needs to be assured that she/he will be able to acquire the full value of the acquired business. Thus, as a general rule, restrictions which benefit the seller are either not directly related and necessary to the implementation of the merger at all, or their scope and/or duration need to be more limited than that of clauses which benefit the purchaser.

#### ***Non-competition clauses***

11. Non-competition obligations which are imposed on the seller in the context of the transfer of an enterprise can be directly related and necessary to the implementation of the merger. In order to obtain the full value of the enterprise transferred, the purchaser must be able to benefit from some protection against competition from the seller in order to gain the loyalty of customers and to assimilate and exploit the know-how. Such non-competition clauses guarantee the transfer to the purchaser of the full value of the assets transferred, which in general include both physical assets and intangible assets, such as goodwill or know-how. These are not only directly related to the merger but are also necessary to its implementation because, without them, there would be reasonable grounds to expect that the sale of the enterprise could not be accomplished.
12. However, such non-competition clauses are only justified by the legitimate objective of implementing the merger when their duration, their geographical field of application, their subject matter, and the persons subject to them do not exceed what is reasonably necessary to achieve that end.
13. Non-competition clauses are justified for periods of up to three years, when the transfer of the enterprise includes the transfer of customer loyalty in the form of both goodwill and know-how. When only goodwill is included, they are justified for periods of up to two years.

14. By contrast, non-competition clauses cannot be considered necessary when the transfer is in fact primarily physical assets (such as land, buildings or machinery) or exclusive industrial and commercial property rights (the holders of which could immediately take action against infringements by the transferor of such rights).
15. The geographical scope of a non-competition clause must be limited to the area in which the seller has offered the relevant products or services before the transfer, since the purchaser does not need to be protected against competition from the seller in territories not previously penetrated by the seller. That geographical scope can be extended to territories which the seller was planning to enter at the time of the transaction, provided that it had already invested in preparing this move.
16. Similarly, non-competition clauses must remain limited to products (including improved versions or updates of products as well as successor models) and services forming the economic activity of the enterprise transferred. This can include products and services not yet fully developed or marketed at the time of the transaction.
17. The seller may bind itself and its subsidiaries and commercial agents. However, an obligation to impose similar restrictions on others would not be regarded as directly related and necessary to the implementation of the merger. This applies, in particular, to clauses which would restrict the freedom of resellers or users to import or export.
18. Clauses which limit the seller's right to purchase or hold shares in a company competing with the business transferred shall be considered directly related and necessary to the implementation of the merger under the same conditions as outlined above for non-competition clauses, unless they prevent the seller from purchasing or holding shares purely for financial investment purposes, without granting it, directly or indirectly, management functions or any material influence in the competing company.
19. Non-solicitation and confidentiality clauses have a comparable effect and are therefore evaluated in a similar way to non-competition clauses.

### ***Licence agreements***

20. The transfer of an enterprise can include the transfer to the purchaser, with a view to the full exploitation of the assets transferred, of intellectual property rights or know-how. However, the seller may remain the owner of the rights in order to exploit them for activities other than those transferred. In these cases, the usual means for ensuring that the purchaser will have the full use of the assets

transferred is to conclude licensing agreements in its favour. Likewise, where the seller has transferred intellectual property rights with the business, it may still want to continue using some or all of these rights for activities other than those transferred; in such a case the purchaser will grant a licence to the seller.

21. Licences of patents, of similar rights, or of know-how, can be considered necessary to the implementation of the merger. They may equally be considered an integral part of the merger and, in any event, need not be limited in time. These licences can be simple or exclusive and may be limited to certain fields of use, to the extent that they correspond to the activities of the enterprise transferred.
22. However, territorial limitations on manufacture reflecting the territory of the transferred activity are not necessary to the implementation of the operation. As regards licences granted by the seller of a business to the buyer, the seller can be made subject to territorial restrictions in the licence agreement under the same conditions as laid down for non-competition clauses in the context of the sale of a business.
23. Restrictions in licence agreements going beyond the above provisions, such as those which protect the licensor rather than the licensee, are not necessary to the implementation of the merger.
24. Similarly, in the case of licences of trademarks, business names, design rights, copyrights or similar rights, there may be situations in which the seller wishes to remain the owner of such rights in relation to activities retained, but the purchaser needs those rights in order to market the goods or services produced by the enterprise transferred. Here, the same considerations as set out above apply.

### ***Purchase and supply obligations***

25. In many cases, the transfer of an enterprise can entail the disruption of traditional lines of purchase and supply which have existed as a result of the previous integration of activities within the economic unity of the seller. In order to enable the break-up of the economic unity of the seller and the partial transfer of the assets to the purchaser under reasonable conditions, it is often necessary to maintain, for a transitional period, the existing or similar links between the seller and the purchaser. This objective is normally attained by purchase and supply obligations for the seller and/or the purchaser of the enterprise. Taking into account the particular situation resulting from the break-up of the economic unity of the seller, such obligations can be recognised as directly related and necessary to the implementation of the merger. They may be in favour of the



seller as well as the purchaser, depending on the particular circumstances of the case.

26. The aim of such obligations may be to ensure the continuity of supply to either of the merger parties of products necessary for carrying out the activities retained by the seller or taken over by the purchaser. However, the duration of purchase and supply obligations must be limited to a period reasonably necessary for the replacement of the relationship of dependency by autonomy in the market. Thus, depending on the circumstances of the market at issue (including, for example, the typical length of contracts entered into by market participants in the ordinary course of business), purchase or supply obligations aimed at guaranteeing the quantities previously supplied may be justified for a transitional period of up to five years.
27. Both supply and purchase obligations providing for fixed quantities, possibly with a variation clause, are recognised as directly related and necessary to the implementation of the merger. However, obligations providing for unlimited quantities, exclusivity, or conferring preferred-supplier or preferred-purchaser status, are not necessary to the implementation of the merger.
28. Service and distribution agreements are equivalent in their effect to supply arrangements; consequently the same considerations as set out above apply.

## **Principles applicable to commonly encountered restrictions in cases of joint ventures**

### ***Non-competition obligations***

29. A non-competition obligation between the parent companies and a joint venture may be considered directly related and necessary to the implementation of the merger where such obligations correspond to the products, services, and territories covered by the joint venture agreement or its by-laws. Such non-competition clauses reflect, inter alia, the need to ensure good faith during negotiations; they may also reflect the need to fully utilise the joint venture's assets or to enable the joint venture to assimilate know-how and goodwill provided by its parents; or the need to protect the parents' interests in the joint venture against competitive acts facilitated, inter alia, by the parents' privileged access to the know-how and goodwill transferred to or developed by the joint venture. Such non-competition obligations between the parent companies and a joint venture can be regarded as directly related and necessary to the implementation of the merger for the lifetime of the joint venture.

30. The geographical scope of a non-competition clause must be limited to the area in which the parents offered the relevant products or services before establishing the joint venture. That geographical scope can be extended to territories which the parent companies were planning to enter at the time of the transaction, provided that they had already invested in preparing this move.
31. Similarly, non-competition clauses must be limited to products and services constituting the economic activity of the joint venture. This may include products and services at an advanced stage of development at the time of the transaction, as well as products and services which are fully developed but not yet marketed.
32. If the joint venture is set up to enter a new market, reference will be made to the products, services and territories in which it is to operate under the joint venture agreement or by-laws. However, the presumption is that one parent's interest in the joint venture does not need to be protected against competition from the other parent in markets other than those in which the joint venture will be active from the outset.
33. Additionally, non-competition obligations between investors whose level of control falls below material influence and a joint venture are not directly related and necessary to the implementation of the merger.
34. The same principles as for non-competition clauses apply to non-solicitation and confidentiality clauses.

### ***Licence agreements***

35. A licence granted by the parent companies to the joint venture may be considered directly related and necessary to the implementation of the merger. This applies regardless of whether or not the licence is an exclusive one and whether or not it is limited in time. The licence may be restricted to a particular field of use which corresponds to the activities of the joint venture.
36. Licences granted by the joint venture to one of its parents, or cross-licence agreements, can be regarded as directly related and necessary to the implementation of the merger under the same conditions as in the case of the acquisition of an enterprise. Licence agreements between the parents are not considered directly related and necessary to the implementation of a joint venture.

### ***Licence agreements***

37. If the parent companies remain present in a market upstream or downstream of that of the joint venture, any purchase and supply agreements, including service

and distribution agreements are subject to the principles applicable in the case of the transfer of an enterprise.

## Appendix D: Contact details

Contact for further information about the application of competition law to mergers in the UK:

The Mergers Unit  
Competition and Markets Authority  
The Cabot  
25 Cabot Square  
London  
E14 4QZ

**CMA switchboard:** 020 3738 6000

**Email:** [general.enquiries@cma.gov.uk](mailto:general.enquiries@cma.gov.uk)

**CMA website:** [Competition and Markets Authority - GOV.UK \(www.gov.uk\)](http://www.gov.uk)

Additional contact details are available on: [Mergers: How to notify the CMA of a merger - GOV.UK \(www.gov.uk\)](#).