

Proposed Plan

1:50 @ A2

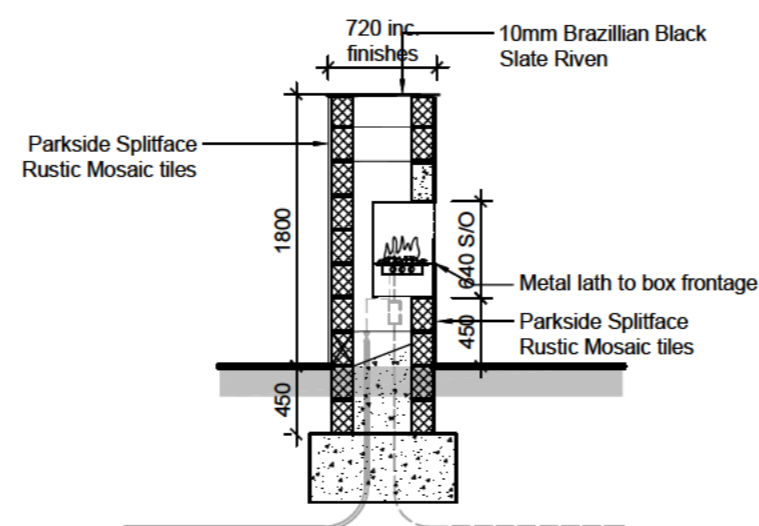

Typical Section A-A

1:50 @ A2

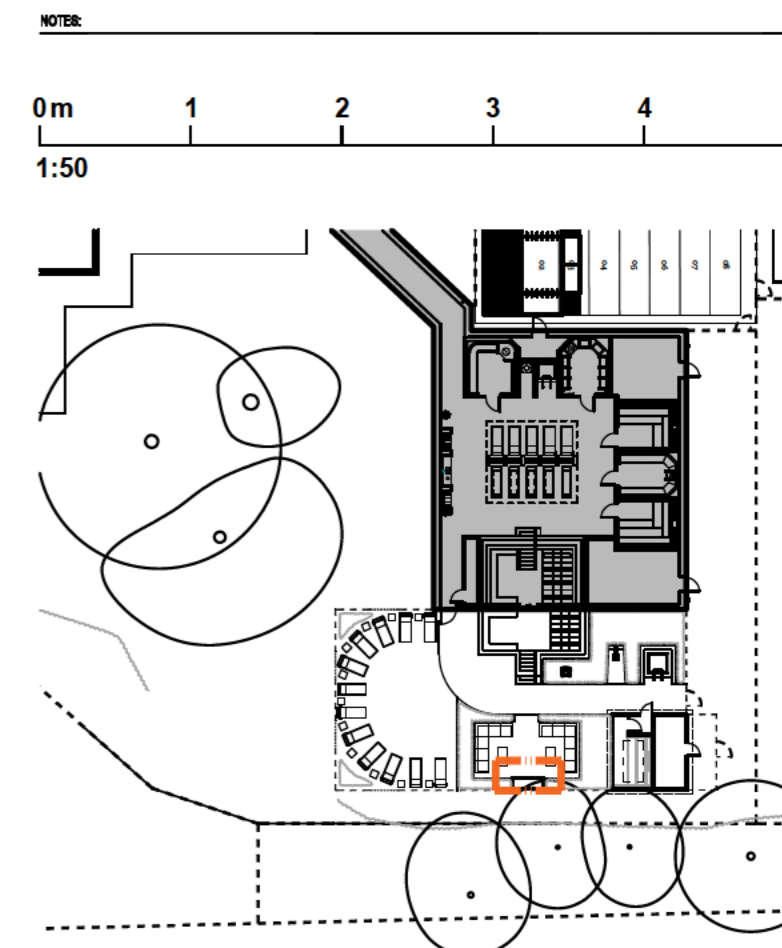

KEY PLAN 1:500

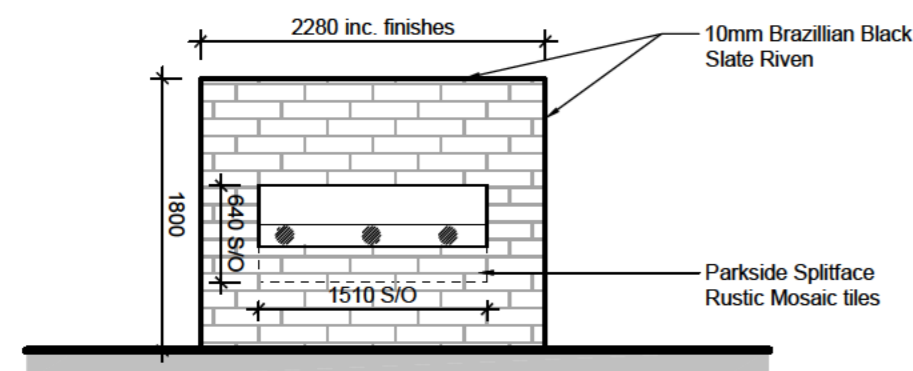

Front Elevation

1:50 @ A2

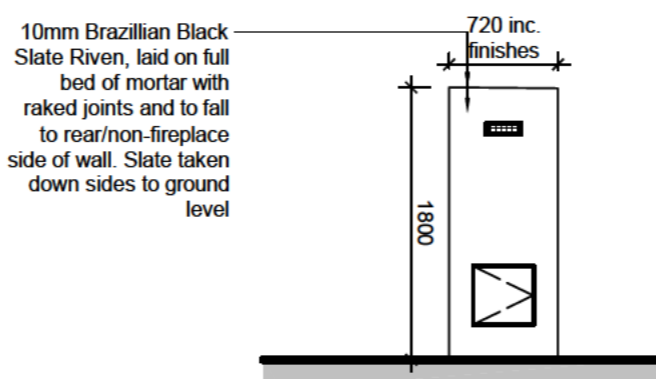

Side Elevation

1:50 @ A2

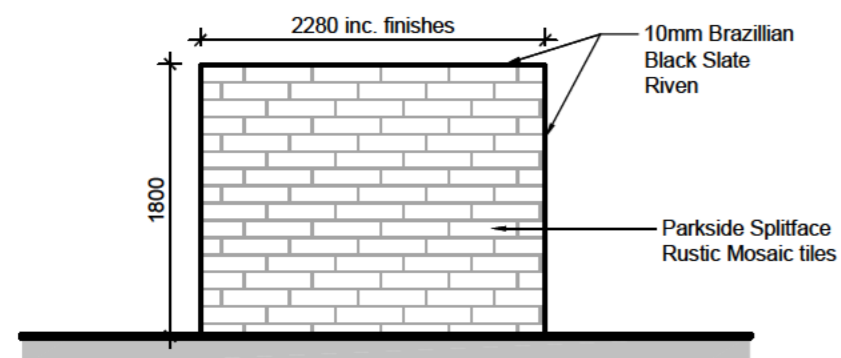

Rear Elevation

1:50 @ A2

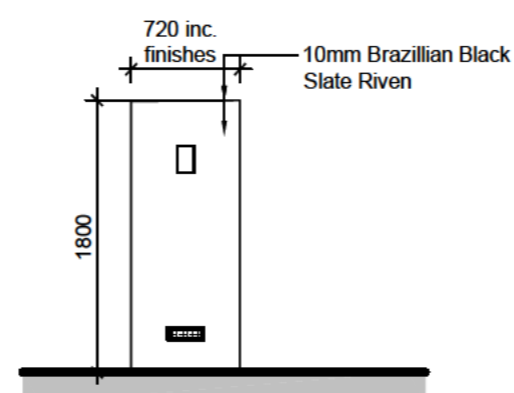

Side Elevation

1:50 @ A2



REVISION: P03	BY: HP	CHECKER: MPB	DATE: 09/10/2024
Updated spa layout			
REVISION: P02	BY: HP	CHECKER: MPB	DATE: 05/03/2024
Updated spa layout			
REVISION: P01	BY: HP	CHECKER: MPB	DATE: 15/02/2024
PLANNING ISSUE			

STATUS

S4a | FOR PLANNING

CLIENT

David Lloyd
CLUBS

PROJECT

**BRISTOL WESTBURY
SPA EXTENSION & SPA GARDEN**

TITLE

**SPA GARDEN
FIREPLACE DETAILS**

Hadfield Cawkwell Davidson

Broomgrove Lodge, 13 Broomgrove Rd, Sheffield, S10 2LZ. T 0114 266 818

HCD PROJECT NO. 2022-319	SCALE 1:50 @ A2	REV. P03
PROJECT NO. 2022-319	ORIGINATOR HCD	VOLUME A0
LEVEL 00	TYPE DR	ROLE + NUMBER A-PL-023