



The Speedmeter Handbook (Fourth Edition)

A Guide to Type Approval Procedures for Speedmeters
Used for Road Traffic Law Enforcement in Great Britain

Publication No. 15/05

Dr S R Lewis

The Speedmeter Handbook (Fourth Edition)

A Guide to Type Approval Procedures for Speedmeters
Used for Road Traffic Law Enforcement in Great Britain

Dr S R Lewis

Publication No. 15/05

THE SPEEDMETER HANDBOOK (FOURTH EDITION)

DR S R LEWIS

FIRST PUBLISHED 2005

© CROWN COPYRIGHT 2005

The text of this publication may not be reproduced, nor may talks or lectures based on material contained within the document be given, without the written consent of the Director, Home Office Scientific Development Branch.

Published by:

Home Office
Home Office Scientific Development Branch
Woodcock Hill
Sandridge
St Albans
Hertfordshire AL4 9HQ
United Kingdom

Archived

Management summary

Proposed changes to road traffic law will facilitate the introduction of new methods of speed detection, especially those that permit automatic and unattended detection by using a camera to record the offending motorist. This handbook contains a description of the technical requirements to be met for consideration of type approval of certain types of speedmeter which are prescribed devices for the purposes of the road traffic legislation. The handbook is intended to be a reference for manufacturers wishing to develop or sell existing products to the Police Service in Great Britain. The handbook contains not only a list of technical requirements but also guidance on methods of measurement, and the procedures to be followed in seeking type approval.

Type approval has been necessary for radar speedmeters since 1984, but the approval procedures previously covered only hand-held and across-the-road models, which were neither capable of taking photographs nor of operating unattended. The opportunity has been taken to reassess the technical parameters and to expand the requirements to cover the use of photography and video to permit automatic and unattended operation. Speedmeters using road surface sensors have also been included.

Preface to the second edition

The second edition of the handbook has been broadened in scope to include speedmeters using sub-surface sensors and optical systems. Previous requirements for radar and sensor speedmeters have not been changed, but the opportunity has been taken to clarify the text in some places.

Preface to the third edition

The third edition of the handbook has been broadened in scope to include controlled motorway over-the-road radar speedmeters, which operate with variable speed limit signs, and the use of cameras producing electronic images. It also covers requirements for the storage of electronic data necessary for its acceptance as evidence by the courts.

Preface to the fourth edition

The fourth edition of the handbook includes amendments to the requirements for over-the-road radar speedmeters that will be operated on motorways with active traffic management where the hard shoulder is temporarily used as a running lane. The electromagnetic immunity tests have been updated, the frequency range and levels amended, and a new simulated TETRA immunity test introduced to test for immunity from police TETRA radios. The new test is not required for automatic systems designed to be operated unattended. The permitted positive speed error has been reduced to be close to the level recommended in Organisation Internationale de Métrologie Légale recommendation 91. The requirements for sensor speedmeters using inductive loop sensors and for systems that combine speed and red light enforcement are now included. Legal advice is that it is not necessary to continue to require evidence from systems using digital imaging to be recorded at the roadside, and reference is now made to separate requirements for the remote recording of this evidence and control of the device.

Contents

	Page
1 Introduction	5
2 Scope	6
3 Terminology	6
3.1 Attended actively operated	6
3.2 Automatic	6
3.2.1 Unattended operation	6
3.2.2 Supervised operation	6
3.3 Beam width	7
3.4 Failure	7
3.5 Radar	7
3.5.1 Hand-held radar	7
3.5.2 Across-the-road radar	7
3.5.3 Variable speed limit above-the-road radar	7
3.6 Surface pressure sensors	7
3.7 Sub-surface pressure sensors	7
3.8 Speedmeter	7
3.9 Optical speedmeter	7
3.9.1 Hand-held	8
3.9.2 Across-the-road	8
3.10 Camera	8
3.11 Measuring zone	8
3.12 Vehicle detector	8
3.13 Recording zone	8
3.14 Start image	8
3.15 Stop image	8
3.16 Recording counter	8
3.17 Inductive loop sensor	9
3.18 Combined traffic light and speed camera	9
4 General requirements for eligibility for type approval	9
5 Operational requirements	10
5.1 General	10
5.2 Test signal	11
5.3 Segmented display	11
5.4 Manual reset	11
5.5 Sensor systems	11
5.5.1 Pressure sensor systems	11
5.5.2 Inductive loop systems	11
5.6 Hand-held radars	12
5.7 Automatic systems	12
5.7.1 Second method of speed measurement	12
5.7.2 Offence data storage	12
5.7.3 Analogue video tape	12

5.8	Optical hand-held speedmeters	13
5.9	Variable speed limits	13
6	Constructional requirements	14
6.1	Components	14
6.2	Power supply	14
6.2.1	Battery operation	14
6.2.2	Vehicle fitting	14
6.2.3	Mains operation	14
7	Performance requirements	15
7.1	Storage	15
7.2	Working temperature range	15
7.3	Robustness	15
7.4	Electromagnetic immunity	15
7.5	Electrostatic discharge	16
7.6	Measuring accuracy	16
7.6.1	General	16
7.6.2	Radar	16
7.6.3	Direction-sensing	16
7.7	Radar operating frequency and power output	16
7.8	Radar antenna characteristics	17
7.8.1	Across-the-road radar	17
7.8.2	Hand-held radar	17
7.8.3	Variable speed limit above-the-road radar	17
7.9	Laser power output	17
7.10	Camera timing accuracy	17
7.10.1	Photographic and digital cameras	17
7.10.2	Video cameras	18
7.11	Vehicle detector speed threshold	18
7.12	Inductive loops	18
8	Measuring methods	18
8.1	General	18
8.2	Speed measurement	19
8.3	Second method of speed measurement	19
8.3.1	Photographic and digital cameras	19
8.3.2	Video cameras	19
8.4	Speed simulators	19
8.4.1	Radar speedmeters	19
8.4.2	Pressure sensor speedmeters	20
8.4.3	Optical speedmeters	20
8.4.4	Inductive loop sensor speedmeters	20
8.5	Environmental tests	20
8.6	Electromagnetic immunity	20
8.6.1	General test arrangements	20
8.6.2	Device specific test arrangement aspects	21
8.6.2.1	Hand-held radar	21
8.6.2.2	All radar	21
8.6.2.3	Vehicle mounted devices	21

8.6.3	Modulation	22
8.6.4	Speed simulators test arrangements and set-up	22
8.6.5	Conducted immunity test	22
8.6.6	Test limits and frequencies	22
8.6.7	Simulated TETRA immunity test	23
8.7	Variable speed limit signs	24
8.8	Stop/start and door alarm frames	25
8.9	Vehicle detector speed threshold	25
9	Type approval procedures	25
	Figures	27-30

Archived

Archived

1 INTRODUCTION

- 1.1** Section 20 of the Road Traffic Offenders Act 1988, as originally enacted, provides that evidence from a radar speed detection device is admissible in a prosecution for exceeding the speed limit only if the device is of a type approved by the Secretary of State. This provision was previously laid down in section 90 of the Road Traffic Regulation Act 1984. In practice, this means that all radar speedmeters used by the police for speed enforcement in Great Britain need to be of a type approved by the Home Secretary. To obtain such approval, a model speedmeter must, among other things, meet specific technical requirements laid down by the former Police Scientific Development Branch (PSDB), now the Home Office Scientific Development Branch (HOSDB). The first type approval specification documents for hand-held and across-the-road radar devices were published by PSDB (now HOSDB) in 1983 and 1984 respectively.
- 1.2** In the White Paper, *The Road User and the Law*, published on 7 February 1989, the Government set out proposals for enabling more effective use of automatic detection devices in the enforcement of road traffic law, particularly speeding and traffic light offences. Statutory provisions to implement these proposals were included in the Road Traffic Act, which received Royal Assent on 25 July 1991. Following this legislation, PSDB published the first editions of the *Speedmeter Handbook* and the *Red Light Camera Handbook* to provide guidance on the type approval requirements for a range of speedmeter devices and red light cameras. These took into account recommendations made by the Organisation Internationale de Métrologie Légale (OIML), and were expanded to include equipment incorporating photography and designed for unattended and automatic operation.
- 1.3** A second edition of the *Speedmeter Handbook* was published by PSDB in 1992 and included technical requirements for speedmeters using optical methods and road surface and sub-surface sensors. A third edition, published in 1997, introduced requirements for the use of electronic images and their storage with other electronic data in ways necessary for their acceptance as evidence by the courts. The opportunity was also taken to include additional requirements that were previously established for controlled motorway over-the-road radar speedmeters which operate with variable mandatory speed limit signs. This fourth edition amends these for use on roads subject to Active Traffic Management where the hard shoulder can be temporarily used as a running lane. It also introduces updated electromagnetic immunity tests and a new simulated TETRA test for testing immunity against police TETRA radios. The positive speed accuracy is amended to be closer to the limit recommended by OIML. Included are the requirements for sensor speedmeters using inductive loops and systems that combine speed and red light enforcement. Reference is made to requirements for the remote recording of digital evidence and for the control of type approved devices.
- 1.4** The type approval procedure consists of a number of technical performance tests which are carried out on a single production model of the type of speedmeter offered for approval by the manufacturer or their appointed agent. The actual testing is carried out by an independent testing laboratory, and is paid for by the manufacturer or their agent. The formal steps necessary to seek approval are described later in section 9 of this guide.

- 1.5 The technical procedures described in this document replace previous requirements. They are intended as a guide to manufacturers and their agents. The procedures will be updated from time to time and amended versions of this guide will be issued subsequently.

2 SCOPE

- 2.1 The test procedures described here are applicable to road traffic speed measuring equipment, including that combined with traffic light cameras, used for law enforcement. The scope of the procedures covers Doppler radar, systems using sensors placed upon the surface of the carriageway, sub-surface sensors, including inductive loop and piezo sensors, and light beams. Equipment may be designed for attended actively operated use or for automatic use, either unattended or supervised and used with a camera or video recorder to record a speeding vehicle.
- 2.2 These requirements may be updated and supplemented by HOSDB and further editions may be published in the future.

3 TERMINOLOGY

3.1 **Attended actively operated**

Equipment designed to be set up and actively operated by a trained user. The accuracy of the evidence from such equipment is verified by the operator in every case at the time of the offence. Such equipment may or may not record an image of an offending vehicle, but its operations are at all times supervised and controlled by the operator, whose evidence of the offence is crucial.

3.2 **Automatic**

A speedmeter which, once set up, works by itself without direct and continuing human intervention and operates with an approved secondary check (see 5.7). Such equipment shall record an image of a speeding vehicle together with the time, date and speed, and, if operated with a variable speed limit sign, direct evidence of the speed limit in force and displayed at that time.

3.2.1 **Unattended operation**

Equipment mounted in an appropriate housing and designed to operate automatically.

3.2.2 **Supervised operation**

Equipment designed to operate automatically but supervised to protect the equipment and the integrity of the evidence.

3.3 Beam width

The beam width of an antenna is the total angle between the half-power points of the main lobe measured for a stated plane of polarisation.

3.4 Failure

A speedometer will be considered to fail a type approval test if it displays an incorrect reading of speed outside the tolerance range of error or if it displays a speed when no measurement should be possible. The display of a blank screen or defined symbol in recognition of an incorrect reading is acceptable.

3.5 Radar

A speedometer employing a continuous wave microwave transmitter and receiver operating on the doppler principle. There are three main types of this device as defined below.

3.5.1 Hand-held radar

A radar in which the microwave beam is directed along the road at the target vehicle.

3.5.2 Across-the-road radar

A radar in which the microwave beam is directed at a known angle across the road.

3.5.3 Variable speed limit above-the-road radar

A radar in which the microwave beam is directed from a fixed installation at a known angle above the road along a specified lane and is operated with a variable speed limit sign.

3.6 Surface pressure sensors

A cable or other device which is intended to be placed upon the road surface such that when a vehicle passes over it some change in its physical properties is produced, e.g. sensors may work by piezo electricity or changes in air pressure.

3.7 Sub-surface pressure sensors

As 3.6, but the sensor is fixed into a slot cut into the road surface.

3.8 Speedometer

A stationary device for measuring the speed of road traffic vehicles.

3.9 Optical speedometer

A speedometer which uses a beam of light in the visible or infrared region of the electromagnetic spectrum. There are two main types of this device as defined below.

3.9.1 Hand-held

An optical speedmeter which consists of a single beam aimed along the road at a target vehicle. The energy reflected is detected and processed to determine the vehicle speed.

3.9.2 Across-the-road

A system of two or more beams of light aimed across a road and detected by separate sensors, or reflected by the road surface, vehicle body or a purpose-built reflector. The speed is determined by the measurement of the time intervals between the interruption of the beams caused by the passing of the target vehicle.

3.10 Camera

A photographic, digital or video camera.

3.11 Measuring zone

A length of road which includes the area within which both the primary speed measurement and the second speed measurement are made (see 5.7.1).

3.12 Vehicle detector

A device or method for detecting the presence of a vehicle approaching the measuring zone above a set speed threshold and automatically triggering an analogue video recorder to begin recording.

3.13 Recording zone

The length of road within which a video camera records on an analogue video recording a vehicle passing through the measuring zone from the vehicle detector to a position beyond the measuring zone.

3.14 Start image

A start image is inserted into an analogue video recording at the beginning of each recording started automatically by the activation of a vehicle detector at the beginning of the recording zone.

3.15 Stop image

A stop image is inserted in to an analogue video recording at the end of each recording started automatically by the activation of a vehicle detector at the beginning of the recording zone and stopped automatically by the expiry of the required recording time (see 5.7.3.2).

3.16 Recording counter

A sequence counter for each recording on an analogue video recording which has been automatically started and stopped since the equipment was turned on.

3.17 Inductive loop sensor

A number, typically three, turns of an insulated conductor laid in the carriageway which, when connected to a detector unit, forms a vehicle sensor.

3.18 Combined traffic light and speed camera

A safety camera system that automatically switches between operating as a red light camera or as a speed camera depending on the state of the traffic signal.

4 GENERAL REQUIREMENTS FOR ELIGIBILITY FOR TYPE APPROVAL

- 4.1 The supplier shall provide free of charge a written technical description of the speedmeter, its operation and intended use, and full circuit diagrams to HOSDB when the device is accepted for the practical assessment described in section 9. They shall also provide free of charge a copy of this information together with a speedmeter of the type intended for sale to the testing laboratory carrying out the type approval before the laboratory commences its testing.
- 4.2 No liability for breakage or damage will be accepted by the Home Office or its agents.
- 4.3 The model type shall be indelibly marked on the outside of the meter, together with a serial number which shall be unique to that instrument.
- 4.4 All models, if approved, shall be numbered consecutively.
- 4.5 Any system software or firmware shall be labelled with a version number, and a copy of the program, along with a sample of the memory, shall be left with the Home Office.
- 4.6 Once type approval has been granted, the manufacturer or their agent shall not change either the value or type of the components used, or alter the circuit or the pre-programmed memory of the speedmeter, without permission of the Home Office.
- 4.7 The speedmeters shall be calibrated annually, and a certificate should be issued to this effect and held by the police. A visible sticker showing the date of calibration should be fixed to the meter.
- 4.8 Any repair or calibration shall be carried out by the manufacturer, their appointed agent or a suitably qualified technician offering appropriate evidence of technical and professional competence. Such persons shall keep accurate records which shall be open to inspection by the Home Office.
- 4.9 All equipment used for calibration (but not for repair) shall be certificated annually by a competent body with equipment traceable to national standards.

- 4.10** A handbook or a set of written instructions for the use of the operator shall be provided with the instrument when it is accepted for the practical assessment described in section 9. A copy will be provided to HOSDB. The instructions shall be dated and any subsequent changes agreed with HOSDB sent to all users, including the Home Office.
- 4.11** Any requirement for goods or materials to comply with this specification shall be satisfied by compliance with:
- 1 a relevant standard or code of practice of a national standards body or equivalent body of any member state of the European Community;
 - or 2 any relevant international standard recognised for use in any member state in the European Community;
 - or 3 a relevant technical specification acknowledged for use as a standard by a public authority or by any member state of the European Community;
 - or 4 traditional procedures of manufacture of a member state of the European Community where these are the subject of a written technical description sufficiently detailed to permit assessment of the goods or materials for the use specified;
 - or 5 a specification sufficiently detailed to permit assessment of goods or materials of an innovative nature (or subject to an innovative process of manufacture such that they cannot comply with a recognised standard or specification) and which fulfil the purpose provided by the specified standard, provided that the proposed standard, code of practice, technical specification or procedure of manufacture provides in use equivalent levels of safety, suitability and fitness for purpose.

5 OPERATIONAL REQUIREMENTS

5.1 General

5.1.1 If a camera is used to record a speeding vehicle, it shall have an angle of view sufficient to ensure that the speeding vehicle is clearly identified in relation to the measuring position and other vehicles that may be nearby.

5.1.2 Every image of the offence shall show, in addition to the speeding vehicle, in the following order: the date in day, month and year; and the time in hours, minutes and seconds. In the case of a video recording made in an unattended operation, it shall also include a frame count from the beginning of the recording (see 5.7.3.2). When inductive loop sensors are used, the lane number shall also be included. The indication of the time to the nearest minute is acceptable. If operated with a variable speed limit sign and an enforceable speed limit has been set, the time elapsed since it was set, in hours, minutes and seconds, and direct evidence of the speed limit displayed shall also be shown. A code representing the location of the measurement

shall also be shown. This data shall be imprinted on the image at the time of the speed measurement. If digital images are used, the data shall be recorded with the image at the time of the offence as part of the same offence record. Only complete offence records shall be displayed or output.

5.1.3 The speedometer may be so designed that speed may be measured in either direction, but not in both directions at the same time, i.e. once a measurement has commenced, enforcement in the other direction shall be disabled until the measurement has completed (hand-held devices excepted). Speedmeters designed to record an image of a speeding vehicle shall show the direction of measurement on the image at the time of the speed measurement.

5.1.4 The speedometer shall be provided with an on/off switch and with 'power on' and, if powered by battery, 'battery low' indicators.

5.2 Test signal

The instrument shall be provided with an inbuilt test signal to simulate a measurement. The test signal shall be independent of the measuring circuits, and shall be capable of checking the function and accuracy of all circuits from the sensor input or radar head output onwards. The test signal may operate automatically when the equipment is switched on, but it shall also be available for manual operation. When the test signal operates a camera, the image shall clearly show that a test signal has been generated.

5.3 Segmented display

If a segmented display is used, there shall be a means of checking that all segments are functioning.

5.4 Manual reset

During attended operation, the last speed measured shall remain visible on the display until manually reset. When the display is reset, it shall not be possible to recall to the display any previous reading unless recalled with a displayed image recorded by an approved camera attachment.

5.5 Sensor systems

5.5.1 Pressure sensor systems

All speedmeters incorporating pressure sensors shall be designed to make two measurements by comparing signals from at least three sensors. The two speeds shall then be compared and, if they are within 2 mph, the lower speed shall be displayed.

5.5.2 Inductive loop systems

All speedmeters using inductive loop sensors shall be designed to make two or more measurements which shall be compared, and if they are within 2 mph, the lowest speed displayed. At least two sensors shall be used. If only two sensors are used, the system shall be designed to include at least two measurements from the detection of both vehicle entry and exit times at both sensors.

5.6 Hand-held radars

If audible doppler is provided, it shall be via a loudspeaker built within the body of the device, and shall provide a sound output representative of the doppler signal. A volume control shall be fitted.

5.7 Automatic systems

5.7.1 Second method of speed measurement

A second method of speed measurement involving a different principle (such as two photographs or video frames taken a known time apart) shall be used to verify the primary speed measurement. The accuracy of the second method shall be within 10% of the speed recorded by the primary measurement. The speedmeter shall be set up in traffic and sufficient readings taken to be able to make a valid statistical comparison of the two speed measurements. A test track may be used for this purpose.

5.7.2 Offence data storage

The data to be used as evidence of an offence shall be recorded on either:

- i photographic film;
- or ii a removable digital storage medium which provides a physical record of the data and, once written, cannot be amended with new data;
- or iii analogue video tape on which start and stop images are recorded in accordance with 5.7.3.2 and alarm frames recorded in accordance with 7.3.

If the equipment is constantly supervised to maintain the integrity of the evidential chain then the data may also be recorded on:

- iv removable read/writable digital storage media, provided that two copies are made simultaneously;
- or v analogue video tape.

For unattended equipment, all digital data shall be stored with security codes generated using PSDB published standards for data protection. It shall be recorded at the roadside or requirements published by PSDB for the remote recording from and control of unattended type approved devices complied with. The data protection shall be applied immediately after capture within the tamper-proof cabinet. There shall be no external means of accessing the data without the protection being applied.

5.7.3 Analogue video tape

5.7.3.1 When an analogue video recording is made from automatic equipment in an unattended operation, the camera shall record continuously from when it is switched on until it is switched off or has filled its recording capacity, unless it is automatically controlled by the speedmeter.

5.7.3.2 If it is automatically controlled by the speedmeter, the camera shall insert one or more start frames into the video recording before starting to record when it detects a vehicle at the start of the recording zone above the set speed threshold. In addition to the date

in day, month and year, the time in hours, minutes and seconds, location code and frame count from the beginning of the recording, the start frame shall indicate that it is a start frame and show a recording counter. The camera shall record until no more vehicles are detected entering the recording zone and at least 10 seconds has elapsed since the last vehicle was detected entering the recording zone. Whenever the recording is stopped, the camera shall automatically insert one or more stop frames into the recording. In addition to the date in day, month and year, the time in hours, minutes and seconds, location code and frame count from the beginning of the recording, the stop frame shall indicate that it is a stop frame and show the same recording counter as that in the start frame.

5.7.3.3 The recording counter shall provide a count of the sequence of recordings from when the equipment was turned on.

5.7.3.4 The recording zone shall commence with sufficient distance before the measurement zone to ensure that the entry of all vehicles into it is captured.

5.8 Optical hand-held speedmeters

The instrument shall be provided with a means of checking the sighting device with the true alignment of the light beam.

5.9 Variable speed limits

5.9.1 When used to enforce variable speed limits, the speedmeter shall provide separately an adjustable enforcement threshold for each speed limit that can be displayed and for the National Speed Limit when no speed limit is displayed. The speedmeter shall automatically select the correct enforcement threshold depending on the speed limit displayed or the National Speed Limit when none is displayed.

5.9.2 The speedmeter shall enforce the displayed speed limit (or the National Speed Limit when none is displayed) only when:

- i all the speed limit signs connected to it are correctly displaying the same speed limit, except when the hard shoulder of a motorway is actively managed and that lane may show either the same speed limit or a red X;
- and ii the speed limit has been displayed for one minute or longer. This delay shall be variable to at least five minutes.

The speedmeter shall not enforce speed in the actively managed hard shoulder when the red X is displayed. It shall operate with, and only with, all speed limit signs mounted on the same gantry, facing in the same direction and over the same carriageway, and every one of these signs fully operational.

5.9.3 Whenever the speed limit is changed, a single photograph shall be taken which will show the date in day, month and year and the time in hours, minutes and seconds when the display changed, the new speed limit set and the location code.

5.9.4 Within a variable speed limit, the time shown in photographs shall be within 10 seconds of a broadcast radio clock signal. On power up, the speedmeter shall not commence enforcement until this synchronisation has been established. Enforcement shall stop whenever synchronisation is not maintained or is not confirmed with the radio clock within 14 days.

6 CONSTRUCTIONAL REQUIREMENTS

6.1 Components

The speedmeter shall be constructed of good quality components which shall be clearly marked with their type number or value, either in writing or by a recognised code. Any sensor cables shall also be marked with an identifying mark.

6.2 Power supply

Any part intended to connect to the mains supply shall conform with electrical safety regulations currently in force.

6.2.1 Battery operation

When the speedmeter supply is set at the normal voltage and the supply is gradually reduced below the minimum working voltage, no erroneous reading shall appear. Speed indication shall be inhibited when the power supply voltage varies beyond the design limits.

6.2.2 Vehicle fitting

Equipment operating from a vehicle shall use a separate battery to power the speedmeter, and any charging circuit from the vehicle power supply shall be disconnected when the speedmeter is switched on.

6.2.3 Mains operation

This section shall apply only to speedmeters intended to operate from the public mains supply, and does not relate to safety legislation which is covered by the provisions of Directive 73/23/EEC (Electrical Safety). No erroneous reading shall appear when the following disturbances are applied:

- a variation of power supply voltage from minus 15% to plus 20% of nominal value;
- b variation of power supply frequency from minus 2% to plus 2% of the nominal value;
- c power supply interruptions to any level down to and including:
 - i zero voltage for 10 ms or less;
 - ii 50% of nominal voltage for 20 ms or less;
 - iii 80% of nominal voltage for 50 ms or less;
- d repetitive electrical fast transients to test level 3 of EN 61000-4-4: 1995.

7 PERFORMANCE REQUIREMENTS

7.1 Storage

7.1.1 The speedmeter control unit and any electronic parts of the sensors shall, when out of service, be capable of storage in adverse conditions.

7.1.2 They shall be held for at least three hours at $-25\text{ }^{\circ}\text{C}$ and then $+70\text{ }^{\circ}\text{C}$, with low humidity. The units shall then be allowed to return to room temperature and tested to ensure correct operation.

7.2 Working temperature range

7.2.1 Equipment shall function within specification over a temperature range of at least $-10\text{ }^{\circ}\text{C}$ to $+50\text{ }^{\circ}\text{C}$, with 80% humidity above $20\text{ }^{\circ}\text{C}$. Hand-held devices shall be tested over the range $-10\text{ }^{\circ}\text{C}$ to $+35\text{ }^{\circ}\text{C}$. The temperature shall be varied in $5\text{ }^{\circ}\text{C}$ steps, and the equipment left for 30 minutes or longer to obtain thermal equilibrium; the equipment shall function correctly at each temperature step. For radar devices the frequency of the microwave oscillator shall be checked at each temperature step.

7.2.2 Unattended equipment shall have some form of sensor to prevent the equipment operating beyond the working temperature range.

7.3 Robustness

7.3.1 Equipment shall be constructed so as to be fit for its purpose; in particular, equipment designed for unattended use shall be tamper-proof and, if recording to analogue video tape, opening the enclosure while the equipment is on shall immediately generate the recording of one or more door alarm frames. In addition to the date in day, month and year, the time in hours, minutes and seconds, location code and frame count from the beginning of the recording, the door alarm frame shall indicate that it is a door alarm frame and the equipment shall be able to operate with the door open only if a valid key is inserted into it.

7.3.2 All parts of the equipment which may be exposed to the weather shall comply with the requirement of BS EN 60529 (1992), classification IP 55, for water ingress and dust protection.

7.4 Electromagnetic immunity

7.4.1 The equipment shall be capable of operating without indicating an erroneous reading as follows:

- a in fields of at least 10 V/m from 80 MHz to $2,000\text{ MHz}$;
- b in the presence of common mode currents from 27 MHz to 100 MHz to level 2 of EN 61000-4-6;

and, if designed for attended, actively operated or automatic supervised use

- c in the simulated TETRA fields defined in section 8.6.7 at the levels defined in table 1 of section 8.6.7.4.

7.4.2 For a and c, the basic test procedure defined in EN 61000-4-3 and, for b, the basic common mode injection test procedure defined in EN 61000-4-6 shall be used. Some of the requirements may be met by complying with the provisions of Directive 2004/108/EC (Electromagnetic Compatibility). Under these circumstances, equipment complying with the directive and which has already been granted the certificates of conformity provided for therein shall be exempt from the parts of the type approval procedure covered by the directive.

7.5 Electrostatic discharge

7.5.1 The speedmeter shall be tested in accordance with EN 61000-4-2: 1995. At least 10 single discharges shall be applied to the exposed surface of each separate part of the meter.

7.5.2 For permanent installations, tests may be performed in the final installed position. A maximum test voltage of 4 kV shall be employed, i.e. at level 2.

7.6 Measuring accuracy

7.6.1 General

The speedmeter shall be assessed by comparing its readings with a vehicle fitted with a speed measuring system having an accuracy of at least ± 1 mph. Measurements at different speeds up to the maximum stated by the manufacturer shall be made. Simulated speeds may be used for speeds above 120 mph. The speedmeter shall give a positive error no larger than 2 mph (or 3% above 66 mph) and a negative error of no greater than 5 mph or 10% above 50 mph (see 8.2). For combined red light and speed cameras, the requirements in the latest edition of the *Traffic Light Camera Handbook* shall apply when a red signal is displayed and being enforced. At other times whenever the speed limit is being enforced, the requirements of this handbook apply.

7.6.2 Radar

In the laboratory, the speedmeter shall measure a simulated speed to within ± 1 mph in 10 mph increments from 20 mph to the maximum measuring speed stated by the manufacturer.

7.6.3 Direction-sensing

The equipment while set up at the roadside shall be observed while measuring traffic in alternately the overtaking and receding modes against the direction of traffic; a total of at least 500 vehicles shall pass in each direction. No readings of traffic flowing against the selected direction should be recorded.

7.7 Radar operating frequency and power output

7.7.1 The microwave operating frequency shall be $24.10 \text{ GHz} \pm 25 \text{ MHz}$ over the working temperature range. However, alternate frequencies may become available.

7.7.2 At no distance from the aperture of the antenna shall the power density exceed 5 mW/cm^2 .

7.8 Radar antenna characteristics

7.8.1 Across-the-road radar

7.8.1.1 In the horizontal plane, the -3dB beam width shall be no greater than 5 degrees ($\pm 1^\circ$). Any sidelobes shall be at least -15dB relative to the maximum value of the main lobe. In the vertical plane, the -3dB beam width shall be no greater than 20 degrees, and the front to back ratio shall be at least 30dB .

7.8.1.2 The angle of the radiated beam shall be set by the manufacturer to any angle between 15 and 25 degrees to the direction of the traffic and shall be clearly marked on the antenna. The camera shall be fixed so that its optical axis cannot be changed from the manufacturer's setting without inhibiting the speed measurement.

7.8.1.3 Where equipment is fitted within a vehicle for use in the stationary mode, the manufacturer shall provide a means of checking that the camera and antenna are properly aligned.

7.8.2 Hand-held radar

The half-power beam width shall be no greater than 24 degrees. The first side lobes shall be at least 20dB below the main beam. The front to back ratio shall be at least 30dB .

7.8.3 Variable speed limit above-the-road radar

7.8.3.1 In the horizontal plane, the -3dB beam width shall be no greater than 6.5 degrees (± 1 degree). Any side lobes shall be at least -20dB relative to the maximum value of the main lobe. In the vertical plane, the -3dB beam width shall be no greater than 6.5 degrees (± 1 degree), and the front to back ratio shall be at least 30dB .

7.8.3.2 The angle above the road shall be set to between 20 and 35 degrees.

7.8.3.3 The equipment, while set up above the middle lane of a three or more lane section of motorway, shall not be observed detecting any vehicle passing the measurement point in an adjacent lane; a total of at least 500 vehicles shall pass in each lane.

7.9 Laser power output

The output power of laser(s) used on optical speedmeters must not exceed Class 1 (eye-safe) recommendations as given in British Standard BS EN 60825-1: 2001.

7.10 Camera timing accuracy

7.10.1 Photographic and digital cameras

7.10.1.1 If two images taken of the same vehicle, with a known time interval, are used to confirm the measurement, the timing accuracy of the camera shutter shall be measured. At least 10 measurements shall be made in accordance with 8.3.1, and all measurements shall be within $\pm 1\%$ of the indicated time.

7.10.1.2 Where different intervals may be manually selected, the accuracy shall be measured for the minimum setting.

- 7.10.1.3 If the interval is varied automatically with the speed of the vehicle, the accuracy shall be measured at various speeds between 30 mph and the manufacturer's stated maximum, the interval commencing at the trigger point of the sensor signal used.

7.10.2 Video cameras

- 7.10.2.1 Video cameras linked to the speedmeter shall conform to CCIR standards. If the time between two video frames taken of the same vehicle is used to confirm the measurement, then the time displayed in each frame shall be in hours, minutes and seconds with either:

- i seconds shown to one hundredth of a second;
- or ii a frame count.

If the video frames are taken from different cameras, then the cameras shall be synchronised and use overlapping fields of view to provide common measurement points.

- 7.10.2.2 The interval used shall always exceed 0.5 seconds (i.e. 13 or more frames). Ten measurements of the time interval shall be made in accordance with 8.3, and all measurements shall be within $\pm 1\%$ of the interval indicated by the displayed time or the frame count, assuming a frame interval of 40 milliseconds.
- 7.10.2.3 When the frame rate is used, an error message shall be displayed in the image whenever the frame interval does not remain within 1% of 40 milliseconds.

7.11 Vehicle detector speed threshold

The accuracy of speed measurement used by the vehicle detector to determine if vehicles approaching the measurement zone are exceeding the set speed threshold shall be within 10% of the primary speed measurement.

7.12 Inductive loops

When used for speed measurement, the manufacturer shall specify minimum loop spacing. The width of each loop shall be sufficient to cover a single lane of road. The dimensions of each loop shall be the same and all leading edges parallel to within 25 mm.

8 MEASURING METHODS

8.1 General

This section describes suitable methods of measurement for carrying out the tests described in previous sections. It is recommended that the methods are followed to ensure uniformity and repeatability of testing, in particular the method of EMC testing for sensor speedmeters shall be followed. All measuring procedures shall be recorded in the test report.

8.2 Speed measurement

A road or track test shall be performed by driving a car fitted with a speedometer calibrated to within 1 mph (1% above 100 mph) past the speedometer under test at various speeds between 20 mph and the manufacturer's stated maximum, or 120 mph if less. Across-the-road radars shall be set up at a distance of no more than 3 m from the kerb. Sensor systems using inductive loop sensors shall be tested using the minimum loop spacing specified by the manufacturer. If a range of loop dimensions is specified, it shall be tested using loops of both minimum and maximum dimensions. At least 100 measurements shall be taken in each direction.

8.3 Second method of speed measurement

8.3.1 Photographic and digital cameras

8.3.1.1 If two photographs taken of the same vehicle, with a known time interval, are used to confirm the measurement, the timing accuracy of the camera shutter shall be checked.

8.3.1.2 The following measuring method may be used. A light source should be placed in front of the lens, and a light sensor (for example a biased photodiode) placed inside the camera body at the film plane. When the system is operated, a pulse is generated by the sensor each time the shutter opens. This signal can be connected to a suitable counter/timer set to measure the time difference between the two shutter events (figure 1).

8.3.2 Video cameras

The measuring method used may be to video record the display of a suitable continuously running counter/timer to measure the time difference between 13 frames. If frame counts are used to measure the interval, then a further test shall be carried out to show that the system displays an error message whenever the frame interval does not remain within 1% of 40 milliseconds. This may be demonstrated by synchronising the camera to a signal from an external signal generator and varying its frequency to determine the limits at which an error signal is displayed.

8.4 Speed simulators

8.4.1 Radar speedmeters

Simulated speed in the laboratory shall be carried out by generating the Doppler signal at the operating frequency. This may be achieved for non-directional hand-held radars by using a simple modulator consisting of a loudspeaker cone covered with metallic foil and excited with an appropriate frequency F_d . The cone should be placed a few inches in front of the device under test (figure 2). Directional radars require either a single sideband modulator (figure 3) or equivalent mechanical device (figure 4). The appropriate test frequency (F_d) can be calculated from the equation:

$$F_d = \frac{2vf \cdot \cos\theta}{3 \times 10^8}$$

Where F_d = frequency of Doppler signal (Hz)

f = measured frequency of transmitted signal (Hz)

v = speed of vehicle (m/s)

θ = angle of beam to direction of movement

8.4.2 Pressure sensor speedmeters

Pressure sensor devices, require a special speed simulator: for electrical cable sensors, a suitable signal simulator capable of generating repetitive pulses equivalent to about 30 mph shall be connected in parallel with the sensor cables at the point where they enter the impedance transformer; speedmeters employing air tubes shall be replaced by an appropriate air-driven speed simulator.

8.4.3 Optical speedmeters

For hand-held devices, the range measurement of a target may be used instead of a speed simulator. Manufacturers shall supply an appropriate simulator for across-the-road devices.

8.4.4 Inductive loop sensor speedmeters

For systems employing inductive loops, laboratory tests may be carried out using substitute inductance instead of full-size loops.

8.5 Environmental tests

8.5.1

At each temperature step in the working temperature range, the equipment shall be checked by performing an internal calibration check and a simulated speed measurement. If the speedmeter is operated with a variable speed limit sign, for the simulated speed measurement it shall be connected to a sign, or a simulator of the sign, with a correct speed limit displayed. After a speed measurement exceeding the enforcement threshold is simulated, further simulations of the same speed measurement shall be made after the displayed speed limit is lowered until enforcement is again enabled. No enforcement shall occur for at least one minute after the displayed speed limit is changed.

8.5.2

Care shall be taken to ensure that any fans, thermostats, or other electronic control devices associated with the environmental chamber do not cause spurious readings during the testing cycle.

8.6 Electromagnetic immunity

8.6.1 General test arrangements

8.6.1.1

The test arrangements are applicable to both radiated and conducted tests. The object of the test is to confirm that the speedmeter is capable of operating in the presence of electromagnetic fields without recording an erroneous speed reading.

8.6.1.2

The layout of the speedmeter shall be representative of the normal operating conditions, in so far as this will permit a repeatable measurement. The measurement shall be carried out in screened test facilities described in EN 61000-4-3, with the equipment set up as intended for use. The field uniformity criteria of EN 61000-4-3 apply for the radiated immunity tests.

8.6.1.3

The speedmeter to be tested is placed centrally in the calibrated test area. The device and its wiring are mounted on a non-conducting bench 0.8 m above the ground plane (figure 5). Devices designed to operate on a tripod shall be adjusted to be 1 m above the ground.

- 8.6.1.4 Any associated cable bundles/wiring shall be arranged in general accordance with EN 61000-4-3. At least 1 m of the cabling from the device to the test facilities' power supplies must run in the calibrated area. Any interconnecting, remote control, camera or sensor cabling will be treated as follows:
- the manufacturer's specified cable types and connectors shall be used;
 - when the manufacturer's specification requires a wiring length of less than 3 m, then the specified length shall be used. The wiring shall be bundled low-inductively to 1 m in length;
 - when the specified length is greater than 3 m, then the illuminated length shall be a minimum of 1 m. The remainder shall be run outside the calibrated area on the floor, decoupled at the 1 m point by the use of lossy tubes. However, in the case of remote control cables, the remote control unit must be in the calibrated area as shown in figure 5. Therefore the cable length excess greater than 1 m shall be zig-zagged on the floor parallel to and behind the remote sensor cables. The remote control shall be placed as shown in figure 5.
- 8.6.1.5 In at least one orientation of the device, the wiring shall be arranged parallel to the calibrated uniform area of the field.
- 8.6.1.6 The exposed wiring shall be run in a configuration that simulates as closely as possible the manner in which it is run in operation.
- 8.6.1.7 All wiring running on the floor in the calibrated test area shall be spaced 0.1 m from the floor by means of low dielectric spacers.
- 8.6.1.8 Any changes found necessary in the layout shall be recorded in the test report.
- 8.6.1.9 The device under test shall be irradiated by both horizontal and vertical polarised fields from four orthogonal illumination angles. Figure 6 shows a plan view of a typical test arrangement.

8.6.2 Device specific test arrangement aspects

- 8.6.2.1 Hand-held radar
If the device is fitted with radio frequency detection such that the display is disabled and an indication shown that interference is present, it shall not come into operation at fields below 3 V/m.
- 8.6.2.2 All radar
The radar target simulator shall be adjusted so that the radar return signal at the device under test is 10dB above the threshold for reliable operation of the device.
- 8.6.2.3 Vehicle mounted devices
For devices mounted in a vehicle, the device under test shall be connected to simulate the vehicle installation and mounted on the non-conducting test bench. The power supply lines shall be 1 m long and connected to a 12 volt lead acid battery also placed on the bench.

8.6.3 Modulation

8.6.3.1 All test signals shall be 90% amplitude modulated with an appropriate signal depending on the device. During these tests, a speed simulator shall be used to monitor the correct operation of the equipment under test. For radar devices, sinusoidal modulation shall be used and the frequency calculated from the equation given in section 8.4.1. If the speedmeter is operated with variable speed limit signs, a sign shall be connected to it and the speed simulation procedure described in section 8.5.1 used.

8.6.3.2 Pressure sensor systems shall employ a modulation frequency equivalent to the timing period to be expected from pulses generated by a passing vehicle. Square wave modulation of more than 90% shall be used.

8.6.4 Speed simulators test arrangements and set-up

8.6.4.1 Care shall be taken to ensure that the connection of the simulator does not degrade the immunity of the equipment under test.

8.6.4.2 The speed simulator shall be set to a different speed to that of the modulation specified in section 8.6.3 (e.g. 30 mph for the simulator and 40 mph for the test signal). The display of the device shall be monitored throughout the test period, and any erroneous readings or inconsistency in behaviour noted together with the appropriate test frequency and field intensity.

8.6.4.3 For hand-held optical speedmeters, target range may be displayed as a substitute for speed simulation.

8.6.5 Conducted immunity test

The test is conducted in basic accordance with EN 61000-4-6, with the following test method deviations:

- The clamp injection procedure is to be used with the signal being applied to the total cable bundle, i.e. common mode injection. The signal is injected at each electronic unit of the device under test connector by connector. The current probe monitoring the injected current is placed 0.05 m from the device's connector on the bundle under test. The injection clamp is placed 0.05 m from this.
- The modulation and limits are as defined in sections 8.6.3 and 7.4.

8.6.6 Test limits and frequencies

8.6.6.1 The test limits defined in section 7.4 for a) the standard radiated immunity test and b) the standard conducted immunity test are in terms of the cw value of the signal, the modulation being applied on top giving peak readings 90% higher than the cw limit.

8.6.6.2 The RF signal shall be applied at each test frequency at the test limit for a time long enough to fully operate the device under test. The frequencies shall be stepped incrementally across the test range with a step size not exceeding 1% of the previous frequency. If any effect is observed, the applied signal shall be reduced by 12dB and increased in steps of 3dB until the required test level is reached. The level at which the threshold of any effect is observed shall be logged and recorded in the test report.

8.6.7 Simulated TETRA immunity test

- 8.6.7.1 The device under test shall be irradiated with both horizontal and vertical polarised fields from four orthogonal illumination angles in turn.
- 8.6.7.2 The device shall be tested at each of the test frequencies specified in section 8.6.7.3 by increasing the field, at each test frequency, from a minimum level of 12dB down from the appropriate test limit in steps of 3dB until the test level is achieved. The level at which the threshold of any effect is observed shall be logged and recorded in the test report.
- 8.6.7.3 The test frequencies to be used for this test are: 380, 385, 390, 395, 400, 405, 410, 415 and 420 MHz. The tolerance on these frequencies is ± 0.1 MHz.
- 8.6.7.4 The test limit is in terms of the peak value of the modulated signal as measured using a peak detector calibrated in terms of the equivalent rms sine wave value that would give the same reading. This is the standard calibration for all peak detector functions on EMC receivers or spectrum analysers.

The test limits are specified in table 1 for the device categories defined in the table and the minimum permitted operating distance from police TETRA radios.

Table 1 Simulated TETRA immunity test levels for device categories A to D

Category	Definition	Field strength V/m	Comment
A	Hand-held attended actively operated devices and not operated within vehicles	65	Can be operated to within 0.2 m of a personal 1 W TETRA radio antenna and 1.5 m of a 3 W vehicle mounted TETRA radio antenna
B	All other (non-category A) attended actively operated devices and automatic supervised devices not operated within vehicles	20	Can be operated to within 1 m of a personal 1 W TETRA radio antenna and 4 m of a 3 W vehicle mounted TETRA radio antenna.
C	Hand-held devices operated within vehicles and not connected to the vehicle	$x^{(1)}$	Field enhanced by internal vehicle reflections One operator carried 1 W TETRA radio operating inside the vehicle with its antenna at least 0.2 m from the device
D	Vehicle mounted devices with an external antenna	$x^{(1)}$	No operator carried TETRA radios operating inside the vehicle Can be operated to within 1 m (line of sight) of the antenna of a 3 W vehicle mounted TETRA radio

Note 1 Level as set by HOSDB

8.6.7.5 The modulation to be applied shall be an 18 kHz square wave modulation with a depth greater than 98% additionally gated on and off at 17 Hz. The duty cycle shall be 50%. This is shown in figure 7.

8.6.7.6 The test limits are in terms of the peak value of the signal when measured using the peak detector function of the measuring receiver/spectrum analyser. This is calibrated in terms of the equivalent rms value of a sine wave as defined by:

“When measuring a modulated signal, the bandwidth of the measuring receiver should be set wide enough to capture the total energy of the signal. The amplitude reading as measured by the peak detector function is noted. The unknown signal is disconnected and a sine wave signal at the same frequency fed in. Its amplitude is adjusted until the same reading is produced on the measuring receiver. This amplitude is expressed in terms of the rms value of the sine wave, e.g. a 1 volt rms sine wave input will give an indicated measurement of 1 volt. This will not change if the signal is switched on and off: the peak reading will still be 1 volt, hence the term peak rms.”

8.6.7.7 The characteristics of the equipment to be used to measure the amplitude of the applied susceptibility test are:

- The amplitudes associated with the test limits are based on the peak of the rms envelope over the complete modulation period.
- Amplitude measurements shall be made in a manner that clearly establishes the peak amplitude of the modulated waveform.
- The measuring instrument must have a fast enough time response to respond to signal amplitude variations. A spectrum analyser may be used.
- The detection, resolution and video bandwidths of the measuring instrument must be wider than the modulating frequency.
- The measurement bandwidth shall be increased until the amplitude of the measured signal does not change by more than 1dB for a factor of three change in bandwidth. This bandwidth setting shall then be used for the test. At the proper setting the individual modulation side bands will not be resolved.

8.6.7.8 It is important to meet these requirements, especially when measuring modulated signals. The use of a spectrum analyser for signal measurement during susceptibility testing provides advantages over power meters or receivers as it allows a more direct visual check on the quality of the applied signal during the testing. It provides direct indication if the signal source is becoming non-linear or generating spurious signals. Sometimes, when mismatched, TWT amplifiers have been found to produce parasitic high power oscillations even with no input drive at a frequency that may be well removed from the required test frequency. Regular checks should be made on the quality of the test signal and on the presence of spurious signals.

8.7 Variable speed limit signs

8.7.1 When using a variable speed limit sign or a simulator of the sign connected to the speedmeter, the following fault conditions shall be simulated while a speed measurement of 90 mph is simulated:

- i failure of any bulb used to illuminate any part of the speed limit aspect;
- and ii power up of any extra bulb or bulbs used to illuminate other speed limit aspects and not used in the correct display.

No enforcement shall occur while these fault conditions are simulated.

8.8 Stop/start and door alarm frames

For automatic equipment which records on analogue video tape and is to be used in unattended operations, recordings shall be made to test that the requirements in 5.7.3 and 7.3 have been met. A sequence of at least 10 recordings automatically started by simulating a stream of vehicles detected at the start of the recording zone above the enforcement threshold shall be made. Vehicle gaps above and below 10 seconds shall be simulated. A further recording shall be made by manually commencing recording without the detection of any vehicles being simulated. During the recording, the door shall be opened to generate a door alarm frame and then closed again to allow the recording to continue. The recording may then be stopped manually or by filling the recording capacity. The recordings shall be examined to determine whether the requirements have been met.

8.9 Vehicle detector speed threshold

The accuracy of the speed measurement used by the vehicle detector shall be tested for speed thresholds set at various speeds between 30 mph and 90 mph. At each threshold setting, the lowest speed at which the video recording is triggered shall be measured by simulating different speeds in increments of 1 mph.

9 TYPE APPROVAL PROCEDURES

- 9.1** Manufacturers or their appointed agents seeking type approval should first arrange for the equipment to be demonstrated to the ACPO Roads Policing Enforcement Technology Committee, which will arrange for a practical assessment by one or more police forces. Enquiries should be made to:

The Secretary
 ACPO Roads Policing Enforcement Technology Committee
 Essex Police
 Burghstead Close
 Billericay
 Essex
 CM12 9JZ.

Only when this assessment has been satisfactorily completed, and any necessary modifications made to the speedmeter, should the device be offered for formal type

approval. Requests for type approval should be made to:

Road Crime Section
Public Order and Police Co-operation Unit
Home Office
5th Floor
Fry Building
2 Marsham Street
London
SW1P 4DF.

9.2 Road Crime Section will normally recommend test laboratories to carry out type approval testing in accordance with procedures laid down by HOSDB.* Manufacturers or their approved agents are expected to bear the full costs of the private test laboratory's evaluation work. On completion of their work, the private test laboratory will submit a report on their evaluation of the device to HOSDB. HOSDB will submit the results to Road Crime Section for consideration to be given to obtaining the agreement of the Secretary of State for the Home Department to formal type approval.

9.3 To back up type approval, Road Crime Section prepares a supporting agreement for signature by the manufacturer and by Home Office officials which is primarily directed at preventing the manufacturer from altering the device in question in any way without the prior approval of the Secretary of State. Manufacturers must agree:

- i not to change the device without the agreement of the Secretary of State;
 - ii to ensure that the type and serial number of each device is clearly identified by an indelible marking;
 - iii to ensure that the serial number is unique to each device and that each device is numbered consecutively;
 - iv to ensure that any repair or calibration facility relating to the device is open to inspection;
 - v to supply free of charge to the Secretary of State a full circuit diagram of the device with all the circuit components clearly indicated;
- and vi if required, to supply a device free of charge to the Secretary of State and that the Secretary of State shall not be responsible for any damage caused to the device while it is in his possession.

This agreement must be signed by the manufacturer prior to the Home Secretary signing the formal type approval document.

* The results of checks and tests carried out by the bodies and laboratories of other member states, including in particular those in conformity with EN 45000, will be taken into consideration where such results provide a level of accuracy, fitness and suitability for purpose equivalent to the results of tests carried out in the United Kingdom, and where such bodies and laboratories offer suitable and satisfactory guarantees of technical and professional competence and independence.

Figure 1 Camera shutter timing measurement

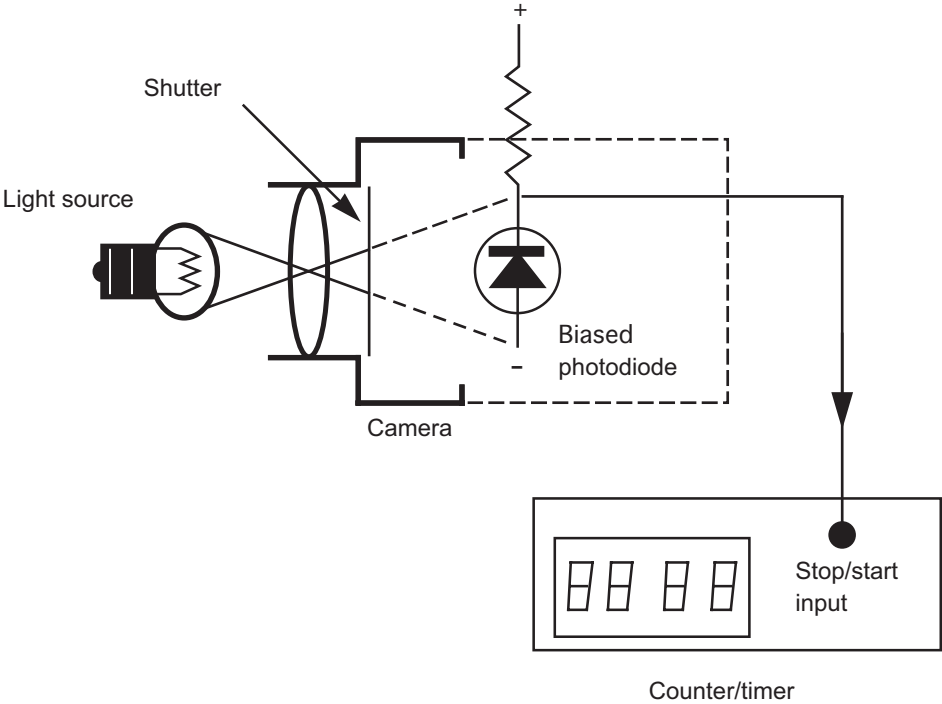

Figure 2 Speed simulator for hand-held radar

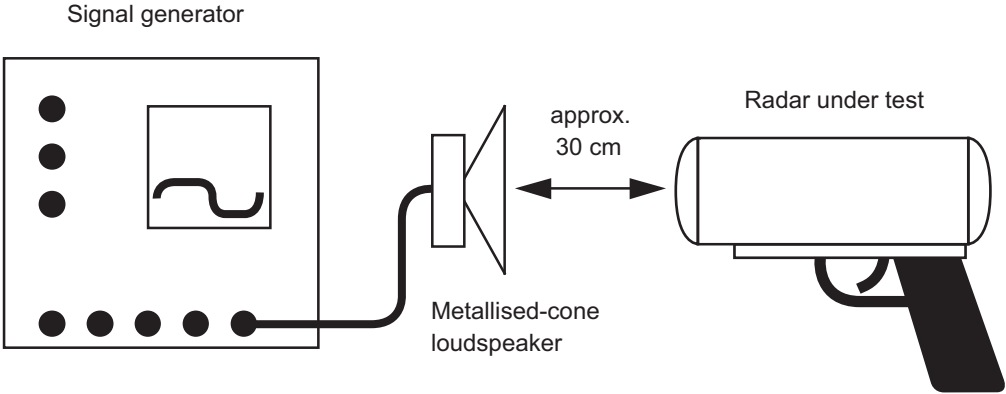

Figure 3 Speed simulator for directional radar using SSB modulator

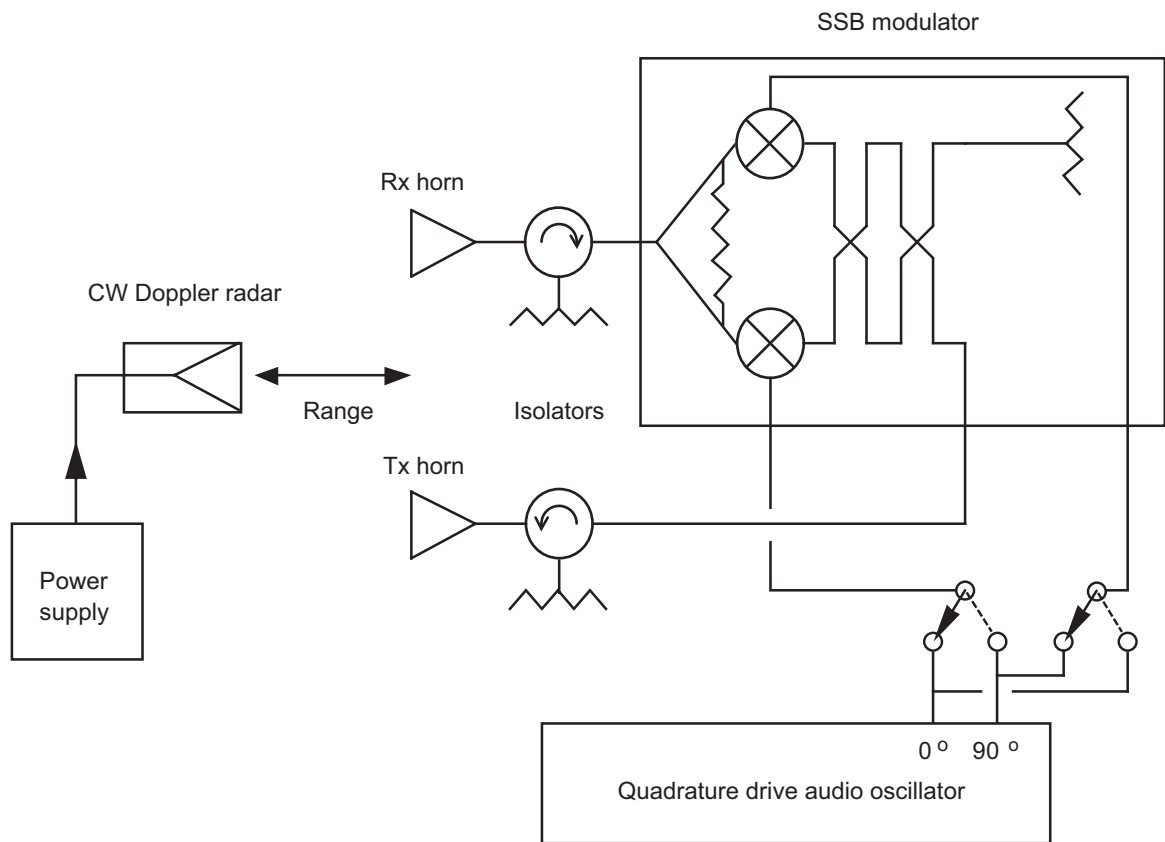

Figure 4 Possible arrangement of a mechanical Doppler simulator

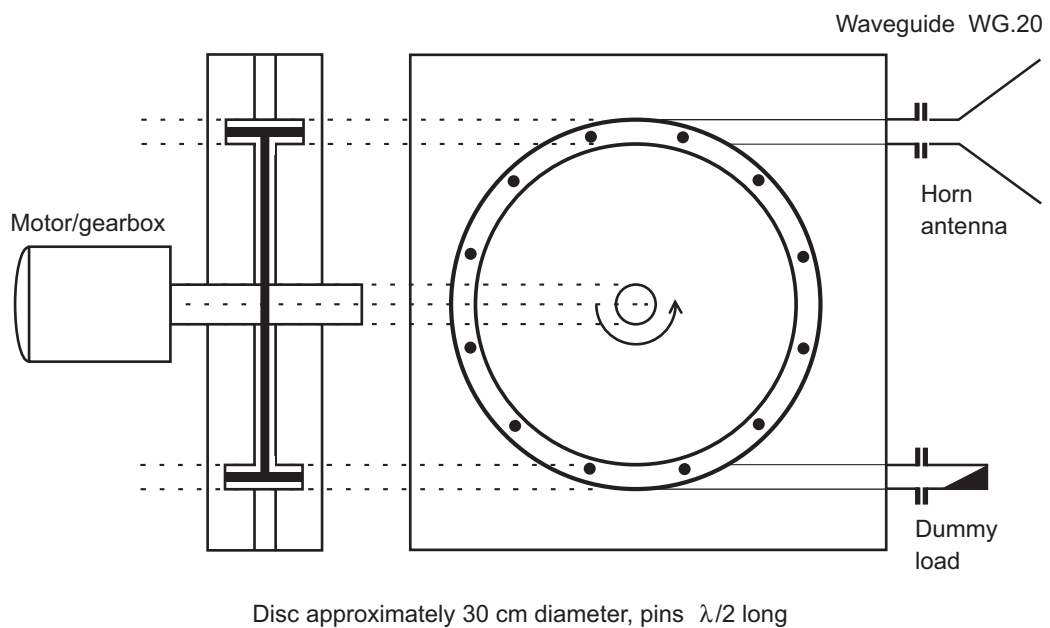

Figure 5 EMC test layout

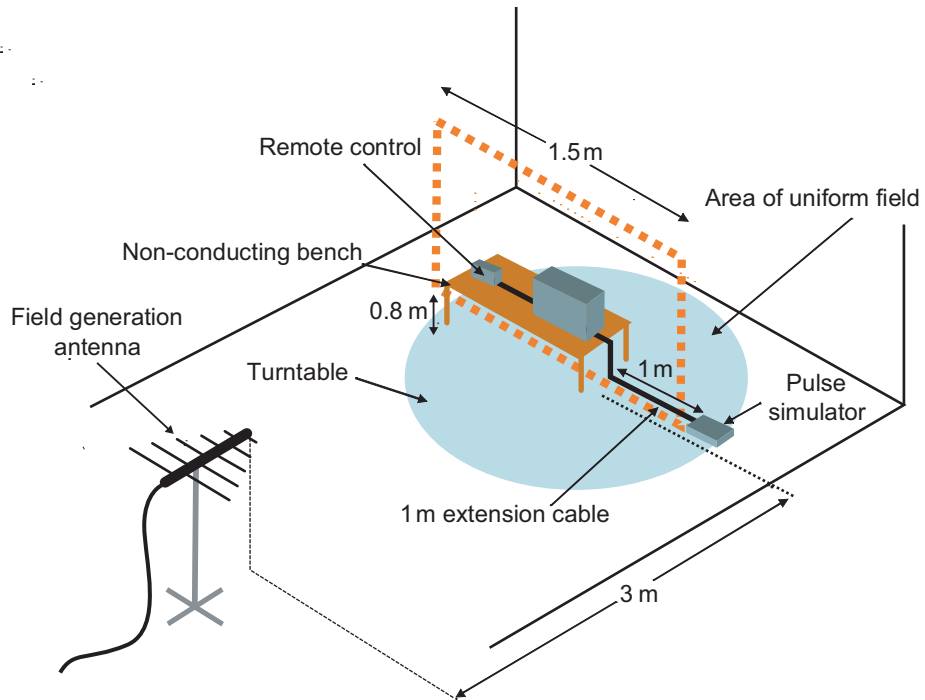

Figure 6 Plan view of a typical EMC test layout

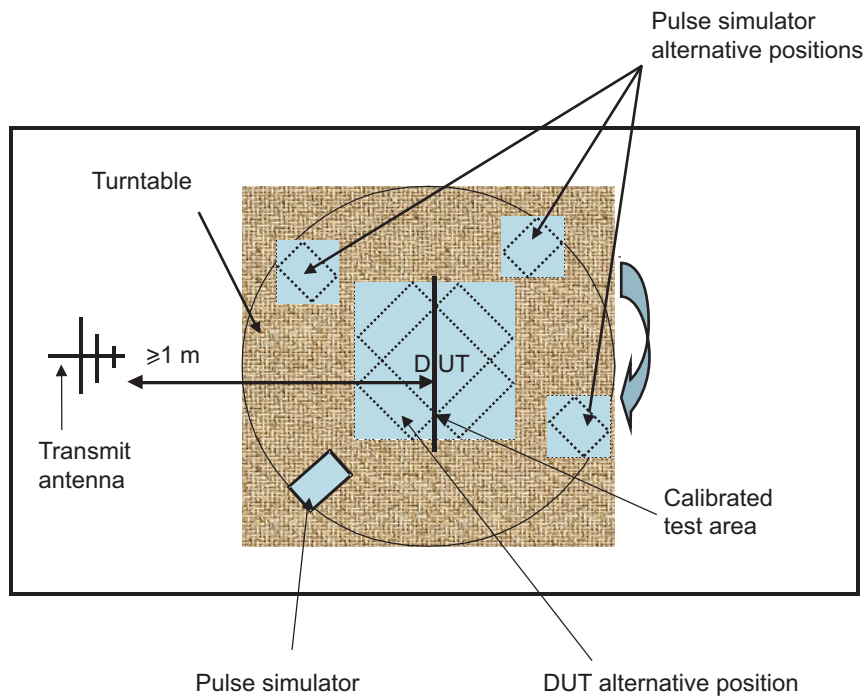
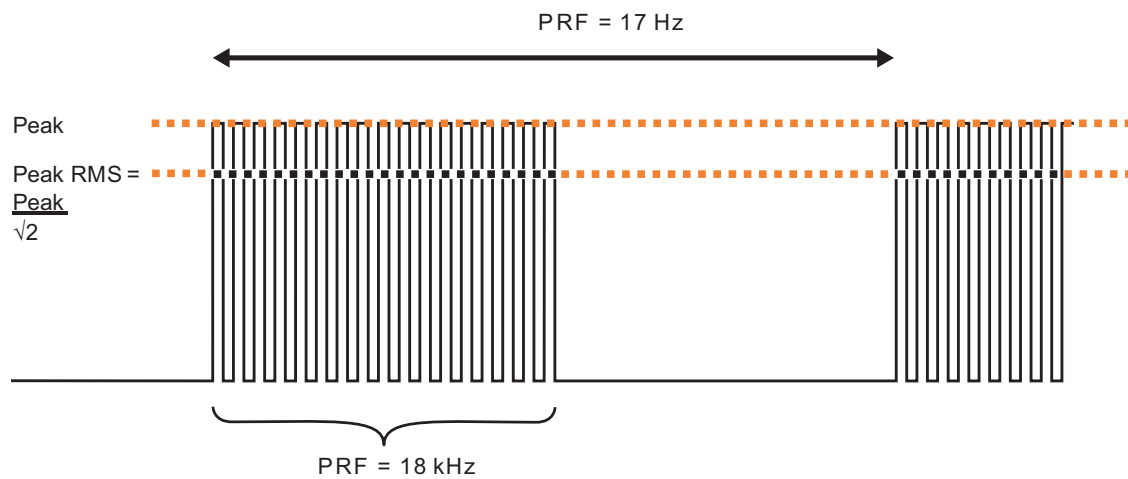



Figure 7 Simulated TETRA test dual modulation envelope





Home Office Scientific Development Branch
Woodcock Hill
Sandridge
St Albans
Hertfordshire AL4 9HQ
United Kingdom

Tel: +44 (0)1727 816400

Fax: +44 (0)1727 816233

Email: hosdb@homeoffice.gsi.gov.uk

Website: www.hosdb.homeoffice.gov.uk