



Driver & Vehicle
Standards
Agency

Individual Vehicle Approval (IVA) Inspection Manual

Light goods vehicles (N1)

October 2024



Keeping **Britain** moving, **safely** and **sustainably**



Driver and Vehicle Standards Agency ©Crown Copyright 2024.

You may re-use this information (not including logos) free of charge in any format or medium, under the terms of the Open Government Licence v3.0.

To view this licence, visit www.nationalarchives.gov.uk/doc/open-government-licence/ or write to the Information Policy Team, The National Archives, Kew, London TW9 4DU, or email: psi@nationalarchives.gsi.gov.uk

Any enquiries regarding this publication should be sent to us at enquiries@dvsa.gov.uk

This publication is also available on the GOV.UK website at

<https://www.gov.uk/government/publications/iva-manual-for-vehicle-category-n1>

Contents Page

Foreword	
Non-European and Other Acceptable Standards	
IVA Manual with Basic Requirements	
01 Noise	
02A Visual Emissions	
02B Metered Emissions	
02C Diesel Emissions	
03A Fuel Tanks	
04 Rear Registration Plate Space	
05 Steering Effort	
06 Door Latches and Hinges	
07 Audible Warning	
08 Indirect Vision	
09A Brake Systems	
09B Service Brake Control / Mechanical Components	
09C Park Brake Control / Mechanical Components	
09D Hydraulic and Vacuum Systems	
09E Brake Performance	
10 Electromagnetic Compatibility	
13A Anti - Theft / Immobiliser	
13B Anti – Theft / Alarm	
14 Protective Steering	
15 Seat Strength	
17 Speedometer and Reverse Gear	
18 Statutory Plates	
19 Seat Belt Anchorages	
20 Installation of Lights	
21 Retro Reflectors	
22 End-outline, Position (Side), Stop, Side Marker & Daytime Running Lamps	
23 Direction Indicators	
24 Rear Registration Lamps	
25 Headlamps	
26 Front Fog Lamps	
28 Rear Fog Lamps	
29 Reversing Lamps	
30 Parking Lamps	
31 Seat Belts	
32 Forward Vision	
33 Identification of Controls	
34 Defrost / Demist	
35 Wash Wipe	
36 Heating Systems	
45 Safety Glass	
46 Tyres	
48 Masses and Dimensions	
49 Exterior Projections of Cabs	
50 Couplings	
60 Frontal Protection System (Bull bar)	
69 Electric/Hybrid Vehicles	
General Construction	
Normal IVA Requirements	
01 Noise	
02 Emissions	
09 Braking	
13A Anti – Theft / Immobiliser	
13B Anti – Theft / Alarm	
14 Protective Steering	
19 Seat Belt Anchorages	
39 Fuel Consumption / CO2 Emissions	
54 Side Impact	
62 Hydrogen Powered Motor Vehicles	
69 Electrical Safety	
Glossary of Terms	

This page intentionally left blank

Version Control & Release Notes

Section Number	Section Title	Revision Date	Revision Number
-	Foreword	01/04/2022	10
-	Non-European and Other Acceptable Standards	09/10/2024	8
-	Manual with Basic Requirements	18/04/2011	1
01	Noise	01/09/2020	2
02A	Visual Emissions	18/04/2011	1
02B	Metered Emissions	01/09/2020	6
02C	Diesel Emissions	01/07/2018	2
03A	Fuel Tanks	09/10/2024	5
04	Rear Registration Plate Space	18/04/2011	1
05	Steering Effort	18/04/2011	1
06	Door Latches and Hinges	03/04/2018	3
07	Audible Warning	01/07/2018	3
08	Indirect Vision	01/09/2020	5
09A	Brake Systems	18/04/2011	1
09B	Service Brake Control / Mechanical Components	03/04/2018	2
09C	Park Brake Control / Mechanical Components	01/09/2022	3
09D	Hydraulic and Vacuum Systems	18/04/2011	1
09E	Brake Performance	01/07/2018	6
10	Electromagnetic Compatibility	18/04/2011	1
13A	Anti - Theft / Immobiliser	05/10/2015	2
13B	Anti - Theft / Alarm	01/09/2020	4
14	Protective Steering	09/10/2024	3
15	Seat Strength	18/04/2011	1
17	Speedometer and Reverse Gear	09/10/2024	6
18	Statutory Plates	03/04/2018	6
19	Seat Belt Anchorages	01/09/2020	4
20	Installation of Lights	09/10/2024	8
21	Retro Reflectors	18/04/2011	1
22	End-outline, Position (Side), Stop, Side Marker & Daytime Running Lamps	09/10/2024	7
23	Direction Indicators	09/10/2024	5

Section Number	Section Title	Revision Date	Revision Number
24	Rear Registration Lamps	01/09/2020	2
25	Headlamps	09/10/2024	8
26	Front Fog Lamps	31/10/2011	2
28	Rear Fog Lamps	03/04/2018	5
29	Reversing Lamps	09/10/2024	4
30	Parking Lamps	05/10/2015	2
31	Seat Belts	05/10/2015	2
32	Forward Vision	03/04/2018	2
33	Identification of Controls	18/04/2011	1
34	Defrost / Demist	01/07/2018	2
35	Wash Wipe	22/05/2023	2
36	Heating Systems	05/10/2015	2
45	Safety Glass	03/04/2018	4
46	Tyres	09/10/2024	5
48	Masses and Dimensions	22/05/2023	7
49	Exterior Projections of Cabs	22/05/2023	5
50	Couplings	01/07/2018	6
60	Frontal Protection System (Bull bar)	01/09/2020	4
69	Electrical Safety	09/10/2024	6
-	General Construction	22/05/2023	3
-	Normal IVA Requirements	18/04/2011	1
01	Noise	03/04/2018	2
02	Emissions	09/10/2024	6
09	Braking	01/04/2022	3
13A	Anti - Theft / Immobiliser	01/09/2020	3
13B	Anti - Theft / Alarm	01/09/2020	3
14	Protective Steering	31/10/2011	2
19	Seat Belt Anchorages	05/10/2015	3
39	Fuel Consumption / CO2 Emissions	18/04/2011	1
54	Side Impact	18/04/2011	1
62	Hydrogen Powered Motor Vehicles	01/09/2020	2
69	Electrical Safety	09/10/2024	4
-	Glossary of Terms	01/04/2022	6

Release Notes

Version 9.0

Section Number	Section Title	MOI change	Required Standards	TSE Incorporated	Details
-	Non-European Standards	Y	-	Yes	All Footnotes to table renumbered. Add Footnote 1 to Table referenced from 01 Noise (all) relating to a noise test requirement & Add Footnote 5 to Table referenced from 02 Emissions (US & Canada) relating to a metered test requirement (TSE IVA N1 ONE 004). Footnote 3 amended to include Australia, & UNECE Regulation 100, & add reference to Footnote 3 for 69 Electrical Safety from 'Other' column. (IVA N1 ONE 007).
03A	Fuel Tanks	N	N	No	Note 3 revised.
14	Protective Steering	N	Y	Yes	Revise Note 1 & add reference to Note 1 from RS5, item iii) (TSE IVA N1 014 004).
17	Speedometer and Reverse Gear	Y	N	Yes	New Note 4 referenced from RS 6; subsequent notes renumbered. (TSE N1 017 003). Note 6 revised & added missing reference to Note 6 from RS 5.
20	Installation of Lights	Y	N	Yes	Revise MOI to clarify consideration of tyres. Paragraph at Figure 1A revised. Revise 'Two or more lamps' paragraph in MOI & add Figure 4b (TSE IVA N1 022 007).
22	End-outline, Position (Side), Stop, Side Marker & Daytime Running Lamps				Note 3 revised. Add footnote to Table 1 relating to symmetrical requirements for Position and End Outline Marker Lamps (TSE N1 020 011).
23	Direction Indicators	N	N	Yes	Note 4 revised & added reference to Note 4 from Table 1
25	Headlamps	Y	N	Yes	New Note 2 referenced from RS10; subsequent notes renumbered. (TSE IVA N1 025 009)

Section Number	Section Title	MOI change	Required Standards	TSE Incorporated	Details
29	Reversing Lamps	N	Y	Yes	Revise RS5 (TSE IVA N1 29 002)
46	Tyres	N	N	No	Annex 3 Tyre capacity table (Load index tyres): Corrected duplicate Load index rating 101 to 100.
69	Electrical Safety	Y	N	Yes	Add detail to MOI to confirm requirements for unmodified mass produced vehicles (TSE IVA N1 69 002).
N 02	Emissions	N	N	No	Table 2 revised.
N 69	Electrical Safety	Y	N	Yes	Add detail to MOI to confirm requirements for unmodified mass produced vehicles (TSE IVA N1 69 002).

Version 8.0

Section Number	Section Title	MOI change	Required Standards	TSE Incorporated	Details
-	Non-European Standards	N	N	Yes	Update table Section 3 (Fuel Tanks) to include acceptance of Japanese Standard for Hydrogen.
-	Non-European Standards	N	N	N/A	Addition of CMVSS 305 to comparable standards table- 69 Electrical Safety
03A	Fuel Tanks	Y	Y	Yes	Removal of reference to outdated Regulations/Directives; Revision of RS17 & Note 3 to include Hydrogen fuel systems. (TSE N1 03A 003)
17	Speedometer and Reverse Gear	Y	Y	N/A	Align permitted speed tolerance in Note 4 with UNECE R39.01 and revise table in RS6.
20	Installation of Lights	Y	Y	Yes	Revise RS1 to include 'red light from a rearmost side marker or rear position lamp. Revise RS6 with reference new Note 9 to clarify 'fixed open position' and renumbering of subsequent notes. Insert additional diagram- Figure 4 and rename existing diagram to 4a. (TSE N1 020 006). Amend Figure 1A text to include reference to flashing side marker lamps. Revise Figure 3 and related text to include 'Zone' area. Add Figure 3a and related text to clarify 'view from the front' (TSE IVA N1 020 007 & TSE IVA N1 022 004).
22	End-outline, Position (Side), Stop, Side Marker & Daytime Running Lamps	N	N	N/A	Add information to Note 7.
23	Direction Indicators	Y	N	Yes	Revise Note 4 to include reference to flashing Side Marker lamps (TSE IVA N1 022 004).
25	Headlamps	Y	Y	N/A	Add information to MOI, Remove RS10 & RS11, New RS10 and remaining RS renumbered. Revise Note 4 to include Regulation 123 & 149.

Section Number	Section Title	MOI change	Required Standards	TSE Incorporated	Details
35	Wash Wipe				Revision of RS6 to allow wipers to rest at a vertical position in the centre of the windscreen.
46	Tyres	Y	N	Yes	Expand Annex 1 to include reference to Tyres rated in excess of 300 km/h (186 mph) (TSE N1 046 002) and Note 1 to include requirements for Retreaded tyres.
48	Masses and Dimensions	N	N	N/A	Clarify access ramps, lift platforms, retractable steps, and similar equipment requirements in Annex 1 Table for Length and Width
49	Exterior Projections of Cabs	N	N	N/A	New Note 7, referenced from RS 2 added.
69	Electrical Safety	N	Y	Yes	Removal of RS3 & re-numbering of remaining RS. TSE IVA N1 069 001.
N69	Electrical Safety	N	Y	Yes	Removal of RS3 & re-numbering of remaining RS. TSE IVA M1 069 001.
-	General Construction	N	Y	N/A	Revise grammar in RS 9.

Version 7.0

Section Number	Section Title	MOI change	Required Standards	TSE Incorporated	Details
	Foreword	N	N		Reg 48.03 added to lighting sections in Summarised List of Requirements
	Non-European Standards	N	N	Yes	FMVSS 305 acceptable as alternative to UN Reg 100 except where traction batteries are lead acid. Clarification of FMVSS statement.
14	Protective Steering	Y	Y		RS 5 amended to correctly reflect RV(A)R 2020; new Note 1 added.
22	End-outline, Position (Side), Stop, Side Marker & Daytime Running Lamps			Yes	Note 7 referenced from RS 6, 11 and 22.
25	Headlamps	Y	Y	Yes	New RS 9, 10 & 11, remaining RS renumbered. Notes 3 & 4 expanded.
69	Electrical Safety	N	N		Section renamed to match RV(A)R 2020, application clarified, reference to glossary added to MOI.
N09	Braking	Y	N		Final paragraph of MOI Removed.
N69	Electrical Safety	N	N		Section renamed to match RV(A)R 2020, application clarified, reference to glossary added to MOI.
	Glossary of Terms	N	N		Definition of Hybrid Electric Vehicle and Off-Road Vehicle added.

Version 6.0

Section Number	Section Title	MOI change	Required Standards	TSE Incorporated	Details
	Foreword	No	No		Correct VLV numbers, add UN reg no for Hydrogen
	Non-European Standards	No	No	Yes	Further clarification regarding USA/CDN spare tyre acceptability.
01	Noise	No	No		Link RS 5 to Notes 2 & 3.
02B	Metered Emissions	Yes	No		MOI para 2 clarified.
08	Indirect Vision	No	No		Correct pole numbering on Alternative Test Procedure diagram.
09C	Park Brake Control/Mechanical Components	No	Yes	Yes	Rewrite RS14 to clarify requirements.
13B	Anti – Theft / Alarm	Yes	No		Remove acceptance of Thatcham Recognised Installer.
17	Speedometer and Reverse Gear	No	No		RS 2 & 6 and Notes 1 & 6 expanded.
19	Seat Belt Anchorages	No	Yes		Correction in Annex 1.
20	Installation of Lights	No	No		New Figure 5 lamp separation added.
24	Rear Registration Lamps	No	No		RS4 linked to Note1.

Section Number	Section Title	MOI change	Required Standards	TSE Incorporated	Details
25	Headlamps	No	No	Yes	Insert new Annex 1 Headlamp Light Sources.
60	Frontal Protection System (Bull Bar)	Yes	No		Clarify Application and MOI.
N13A	Anti – Theft / Immobiliser	Yes	No		Remove acceptance of Thatcham Recognised Installer.
N13B	Anti – Theft / Alarm	Yes	No		Remove acceptance of Thatcham Recognised Installer.
N62	Hydrogen Powered Motor Vehicles	Yes	No		Clarify location of requirements
	Glossary of Terms	No	No		Add definitions of Motor Vehicle, Vehicle and Emergency vehicle.

Time bound concessions to required standards

Section Number	Section Title	End Date	Details	Notes

Foreword

This Manual is a detailed guide on the examination of vehicles submitted to an authorised testing station under the Individual Vehicle Approval (IVA) scheme. It is produced for the examiners who conduct the examinations and for vehicle presenters and other interested parties who wish to familiarise themselves with the technical requirements and inspection procedures.

Application

The IVA scheme is one of three routes for a road vehicle to gain approval and thereby obtain licensing and registration in UK.

The IVA route is open to vehicles falling under the following categories:

M1, M2, M3,
N1, N2, N3
O1, O2, O3, O4

This manual covers solely the IVA technical requirements for vehicles of the following categories:

N1 Light Goods Vehicles

A Light Goods Vehicle (LGV) – Motor vehicle with at least four wheels designed and constructed for the carriage of goods and having a maximum mass not exceeding 3500 kg

N category vehicles are further defined by their bodywork as shown in the table below

EU Code	Name	Definition
BA	Lorry	a vehicle which is designed and constructed exclusively or principally for conveying goods. It may also tow a trailer
BB	Van	a lorry with the compartment where the driver is located and cargo area within a single unit;
BC	Tractor unit for semi-trailer	a towing vehicle which is designed and constructed exclusively or principally to tow semi-trailers;
BD	Road Tractor	a towing vehicle which is designed and constructed exclusively to tow trailers other than semi-trailers;
BE	Pick-up truck	a vehicle of a maximum mass not exceeding 3 500 kg in which the seating positions and the cargo area are not located in a single compartment;
BX	Chassis-cab or chassis-cowl	an incomplete vehicle with just a cabin (complete or partial), chassis rails, power train, axles, which is intended to be completed with bodywork, customised to the needs of the transport operator.

A vehicle defined as a Van with a technically permissible maximum mass not exceeding 3500 kg is not considered to be a vehicle of category N1 where there are more than 6 seating positions, designated for use when the vehicle is in motion (excluding the driver) or, both of the following conditions are met:

(i) the number of seating positions (excluding the driver) is not more than 6 and

(ii) $P - (M + N \times 68) \leq N \times 68$ where:

P = technically permissible maximum laden mass in kg

M = mass in running order in kg

N = number of seating positions excluding the driver.

Determination of the number of seats in a vehicle is as follows; where a seat has no seat belt fitted each 400mm of seat base shall constitute a seat, where seat belts are fitted each seat space with a belt (providing the maximum anchorage separation requirements are not exceeded) is to constitute a seat and any remaining seat base measured to be 400mm or greater is to constitute a seat. All measurements are taken across the front of the seat cushion.

For information on other vehicle categories, the following DVSA IVA inspection manuals should be consulted.

- The Light Vehicle IVA Inspection Manual for vehicle categories of M1
- The Heavy Goods Vehicle IVA Inspection Manual for vehicle categories N2 and N3
- The Bus and Coach IVA Inspection Manual for vehicle categories M2 and M3
- The Trailer IVA Inspection Manual for categories O1, O2, O3 and O4

Approval Process

The IVA scheme for 'N1 vehicles' applies to

- **N1 Basic**
- **N1 Normal**

There are two levels of compliance: Basic and Normal.

1. The Basic IVA

This requires a visual examination of the vehicle to assess its design and construction characteristics against the key UN/EU technical areas and in most cases documentary evidence of compliance is not normally required, except for certain areas such as gaseous fuel tanks.

A vehicle subject to The Basic IVA Requirements is either:

- (a) a left-hand drive vehicle; (Vehicle Class N)
- (b) a personally imported vehicle; (Vehicle Class P)
- (c) an amateur built vehicle; (Vehicle Class A)
- (d) a vehicle manufactured in very low volume; (Vehicle Class L)
- (e) a vehicle manufactured using parts of a registered vehicle; (Vehicle Class C)
- (f) a rebuilt vehicle; (Vehicle Class S)
- (g) an armoured vehicle as defined in Annex II.A of the 2007 Directive. (Vehicle Class T)

2. The Normal IVA

This requires the supply of documentary evidence to prove compliance with up to 12 key areas of EU Directives as listed in the Normal IVA General Requirements section. Compliance with alternative standards may be acceptable where specified. Other areas will be subject to the same requirements as Basic IVA.

A vehicle subject to Normal IVA requirements is either:

- (a) A vehicle not meeting any Basic IVA vehicle class and therefore requiring Normal IVA; (Vehicle Class R) or
- (b) European Approved to the IVA standard of a Member State; (Vehicle Class E)

The standards applicable to Normal IVA are those given in the relevant sections of this manual. In most cases these are dependent on the vehicle's date of manufacture.

For Normal IVA, the onus is on the applicant to provide evidence of compliance. This may be in the form of:

- manufacturer's markings on the vehicle,
- an EC certificate of conformity for an incomplete or base vehicle and details of the systems approved,
- documentary evidence from the competent authority in the country of origin or the manufacturer,
- submission of a VIN specific test report from an accredited testing authority or a combination of such elements and
- It may also include a degree of visual examination and practical tests.

Notes

Applicants may be required to dismantle specific parts of the vehicle to allow DVSA examiners to complete a full examination.

Applications together with any supporting documentation will be assessed prior to the issue of an appointment for examination.

Scope of inspection

The design and construction requirements applicable to road vehicles are contained within the Road Vehicles (Approval) Regulations 2020. The inspection procedures within this manual have been developed to assess as far as practicable the ability of the vehicle to comply with those Regulations. This manual is however not a legal interpretation of the Regulations.

The issue of an Individual Approval Certificate (IAC) should not be taken as absolute evidence that the vehicle can legally be used on the road, since there may be other applicable requirements contained in other regulations.

NOTE: The vehicle will be assessed for compliance in all modes of operation unless otherwise specified, for example

- if dual fueled, when running on each separate fuel source.
- if fitted with a remote engine air/fuel ratio adjustment device in minimum/maximum positions.

Method of Inspection

The presenter may be required to open lockable compartments, remove engine covers, inspection/access panels, trims, carpeting and dismantle certain parts of the vehicle to allow DVSA examiners to carry out a full examination.

Where the vehicle is subject to Basic IVA, only the basic subjects are tested. Where a vehicle is subject to Normal IVA, all the Basic subjects are tested except those where documentary evidence is required or has been provided.

If the examiner has any doubts over any item covered by documentary evidence, calculations, or decelerations, they have the right to ask for the original copies of these approvals / decelerations which were accepted at time of application, to compare against the vehicle they are inspecting.

Examiners shall assess all relevant aspects of the vehicle in respect of its overall construction. In making a decision, the examiner shall compare the materials of construction/manufacture, position, function, and attachment of components and ensure equivalent levels of performance typically found with type approved vehicles

Any item which prevents a meaningful test to be conducted shall be deemed to be “temporary in nature”. The relevant test or assessment shall **not** be conducted, and the IVA 30 (Refusal to issue IAC) will indicate that the item was “unable to be assessed”.

The condition/presence of an item in isolation is not a reason for an item failing to meet the requirements. However, if the condition of an item is such that a meaningful assessment cannot be made, then the IVA 30 should indicate that the applicable section/area was unable to be assessed and state the reason for this action. Examiners are not required to carry out a roadworthiness inspection but where obvious safety defects are noted the vehicle may be subject to prohibition action, The IVA certificate (IAC) will not be issued.

Where an item appears to be missing an assessment should be made of the effect the missing item will have on the suitability for use of the vehicle and the safety of the occupants, pedestrians, and other road users. Where a missing item is considered to have a detrimental effect the IVA 30 (Refusal to Issue IAC) will indicate that either the item was unable to be assessed or that a required standard from the section 'General Construction' has not been met.

Definitions of vehicles eligible for the Basic Scheme

a. Left hand drive vehicle

Vehicles designed for use primarily on the right-hand side of the road

b. Personal Import

A vehicle is a personally imported vehicle if all of the following apply:

- it has been imported by a person entering the United Kingdom (in the case of a serving member of the Armed Forces, is to be imported within 12 months of the date of application)
- that person, at the time the vehicle was imported (in the case of a serving member of the Armed Forces, at the time of application) had been normally resident in a country other than the UK for a continuous period of at least 12 months
- that person intends to become normally resident in the UK
- the vehicle has been in the possession of that person and used by them in the country where he has been normally resident for a period of at least 6 months before its importation, and it is intended for his personal or household use in the UK

c. Amateur Built

A vehicle is an amateur built vehicle if:

(a) the vehicle was, constructed, assembled, or having previously been registered under the 1994 Act, structurally modified, for the personal use of a person (R) who is a relevant individual,

and

(b) the whole, or a substantial part, of the construction, assembly or modification was carried out by R, by one or more relevant individuals acting on behalf, and under the direction, of R or by R and one or more relevant individuals acting on behalf, and under the direction of R.

d. Very Low Volume

A vehicle is of a family of types of which the total number manufactured in the world for any 12 months falling within the period of 36 months immediately before the month in which the vehicle was manufactured does not exceed 500.

NOTE: “family of types” means, of the same manufacturer, of the same basic chassis/floor pan.

e. Vehicles manufactured using parts of a registered vehicle.

A vehicle that

- is constructed or assembled by a person carrying on a business in the course of which motor vehicles are normally constructed or assembled
- is equipped with an engine which has previously been used as the engine of another vehicle which had been registered under the Vehicle Excise and Registration Act 1994 or any earlier Act relating to the registration of mechanically propelled vehicles, and
- is equipped with one or more of the following components taken from the same vehicle as the engine.
 - chassis
 - body
 - suspension
 - transmission
 - steering assembly
 - an axle

f. Rebuilt Vehicle

A vehicle that

- is a previously UK registered vehicle to which the Secretary of State is required by regulation to assign a vehicle identification number, and does not fall within the definition of an “Amateur Built” vehicle or “Vehicle manufactured using parts of a registered vehicle”, and has been rebuilt using a replacement chassis or integral chassis/body which is of the same design and construction as that of the original vehicle and which was supplied for the purpose without having been previously used, or previously formed part of a registered vehicle. Evidence will be required to meet this definition.

g. Armoured Vehicle

A vehicle intended for the protection of conveyed passengers and/or goods and complying with armour plating anti-bullet requirements.

‘Anti - bullet requirements’ shall be interpreted as meaning; the driver and passenger compartment (front, rear and sides including doors and glazing are capable of withstanding ballistic penetration from small arms fire. e.g., materials to EN 1063 or an equivalent level of protection.

Special Purpose Vehicles (SPV)

Certain vehicles are classified as Special Purpose Vehicles. They may be subject to additional exemptions from the required standards, but only where the special function of the vehicle makes it impossible to comply.

N.B.: Vehicles fitted with specialised equipment may be subject to additional exemption where specified in the EU Framework Regulation on items normally assessed by visual examination only (i.e., not subject to mandatory Directive/Regulation compliance). Applicants requesting such exemptions should, at the time of application, submit to DVSA any vehicle specific documentary evidence supporting any such request.

Refusal to examine

The examination of a vehicle may be refused for any of the following reasons

- the vehicle is not submitted for examination at the time and place appointed
- the fee has not been paid
- the vehicle submitted for examination is of the incorrect category
- the vehicle cannot be driven or has insufficient fuel or oil to enable the test to be completed
- the vehicle is presented in a dirty or dangerous condition such as to make it unreasonable for the examination to be carried out
- a load or items on the vehicle are not secured or removed as requested
- a proper examination cannot be carried out because any door, tailgate, boot lid, engine cover, fuel cap or other device designed to be readily opened cannot be opened
- the condition of the vehicle (in the opinion of the examiner) is such that proper examination of the vehicle would involve a danger of injury to any person or damage to the vehicle or any other property
- there is no means of identifying the vehicle, i.e., the vehicle identification number (VIN) is missing or does not relate to the vehicle
- there is evidence to indicate that the VIN of the vehicle has been tampered with to change the identity of the vehicle
- the presenter does not remain in the vehicle or its vicinity and operate the controls, drive the vehicle or to remove or refit panels as requested or is uncooperative.

Run Lock

Run lock systems will be considered on a case-by-case basis.

Work Instructions

Technical Work Instructions relating to the use and operation of equipment and facilities are issued and are made available to DVSA staff via the DVSA internal website. Copies of these instructions can be made available upon request from IVA Technical Services telephone 0300 123 9000 or email enquiries@dvsa.gov.uk

Summarised list of requirements for Basic IVA and Normal IVA for Light Goods Vehicles					
IVA Item Number	Directive Requirement	As Amended by	UNECE Regulation	Basic IVA N1	Normal IVA N1
1 Noise	70/157/EEC	92/97/EEC	51.02	Inspection	Approval
2 Emissions	70/220/EEC / 88/77/EEC	# Age related # See Sections	83.02 / 83.03 / 83.04	Inspection	Approval
3 Fuel tank	70/221/EEC / (EC) 79/2009	2000/8/EC	34.02 67.01 / 110 / 115 / 134	Approval & Inspection	Approval & Inspection
4 Rear registration plate space	70/222/EEC			Inspection	Inspection
5 Steering effort	70/311/EEC	1999/7/EC	79.01	Inspection	Inspection
6 Door latches & hinges	70/387/EEC	2001/31/EC	11.02	Inspection	Inspection
7 Audible warning	70/388/EEC	87/354/EC	28.00	Inspection	Inspection
8 Indirect vision	2003/97/EC	88/321/ EEC	46.02	Inspection	Inspection
9 Braking	71/320/EEC	# Age related #	13.07 13H	Inspection	Approval
10 EMC	72/245/EEC	89/491/EEC	10.02	Inspection	Approval & Inspection
13 Anti-theft	74/61/EEC	95/56/EC	18.02 / 97.00 / 116.00	Inspection	Approval
14 Protective Steering	74/297/EEC	91/662/EEC	12.03	Inspection- GVM < 1500kg	Approval – GVM < 1500kg
15 Seat strength	74/408/EEC	2005/39/EC	17.07	Inspection	Inspection
17 Speedo & reverse gear	75/443/EEC	97/39/EC	39.00	Inspection	Inspection
18 Statutory plates	76/114/EEC	78/507/EEC		Inspection	Inspection
19 Seat belt anchorages	76/115/EEC	# Age related #	14.03 / 14.05	Inspection	Approval

Foreword

Summarised list of requirements for Basic IVA and Normal IVA for Light Goods Vehicles						
IVA Item Number	Directive Requirement	As Amended by	UNECE Regulation	Basic IVA N1	Normal IVA N1	
20	Installation of lighting and signalling devices		48.03	Inspection	Inspection	
21	Retro reflectors		3 / 150 / 48.03*	Inspection	Inspection	
22	End outline, position, stop & side marker lamps		7 / 148 / 48.03*	Inspection	Inspection	
23	Direction indicators		6 / 148 / 48.03*	Inspection	Inspection	
24	Rear registration plate lamp		4 / 148 / 48.03*	Inspection	Inspection	
25	Headlamps		8 / 20 / 31 / 98 / 112 / 123 / 149 / 48.03*	Inspection	Inspection	
25A	Cornering Lamps		119 / 149 / 48.03*	Inspection	Inspection	
26	Front fog lamps		19 / 149 / 48.03*	Inspection	Inspection	
28	Rear fog lamps		38 / 148 / 48.03*	Inspection	Inspection	
29	Reversing lamps		23 / 148 / 48.03*	Inspection	Inspection	
30	Parking lamps		77 / 148 / 48.03*	Inspection	Inspection	
31	Seat belts	77/541/EEC	# Age related #	16.04	Inspection	Inspection
32	Forward Vision	77/649/EEC			Inspection	Inspection
33	Identification of controls	78/316/EEC	94/53/EC		Inspection	Inspection
34	Defrost / Demist	78/317/EEC			Inspection	Inspection
35	Wash / Wipe	78/318/EEC			Inspection	Inspection
36	Heater systems	2001/56/EC		122.00	Inspection	Inspection
39	Fuel Consumption	80/1268/EEC	# Age related #			
45	Safety Glass			43.00	Inspection	Inspection
46	Tyres	92/23/EC	2005/11/EC	64.01 (Temporary use spare)	Inspection	Inspection
48	Masses & Dimensions	97/27/EC			Inspection	Inspection
49	External projections of Cabs	92/114/EC		61.00	Inspection	Inspection

Foreword

Summarised list of requirements for Basic IVA and Normal IVA for Light Goods Vehicles					
IVA Item Number	Directive Requirement	As Amended by	UNECE Regulation	Basic IVA N1	Normal IVA N1
50 Couplings	94/20/EC		55.01	Inspection	Inspection
54 Side Impact	96/27/EC	# Age related #	95.01		Approval
60 Frontal protection systems	2005/66/EC			E- Marked	E- Marked
62 Hydrogen Powered Motor Vehicles	EC/79/2009	EU/406/2010	134	Approval	Approval
69 Electric/Hybrid Vehicles			100.01	Approval & Inspection	Approval & Inspection

Age related# - see relevant sections for further information

* Regulation 48.03 applies to the installation requirements in each lighting section.

Record of Revision

Revision	Date	Description of Change
1	18/04/2011	Version 1
2	31/10/2011	Inserted availability of Work Instructions to public.
3	31/05/2012	Amended section 'Method of Inspection'.
4	11/03/2013	Insert guidance for certain types of vehicle which may be classed M1, amend Directive & Reg. Numbers for item 48.
5	18/03/2013	Remove guidance for certain types of vehicle which may be classed M1.
6	05/10/2015	Revise guide to determine category N1 vehicles, amend bullet point 9 in Refusal to Examine and add new bullet point, update approval process, and insert 'Run-lock' systems. DVSA replaces VOSA. Add sections 62 & 69 to Summarised list of requirements.
7	03/04/18	Update Approval Process, update Run Lock Systems, SPV & Special Equipment note added.
8	01/07/2018	Scope and list of requirements updated.
9	01/09/2020	Correct VLV numbers, add UN reg no for Hydrogen, body type definitions added, update Reg/Directive requirements.
10	01/04/2022	Reg 48.03 added to lighting sections in Summarised List of Requirements.

This page intentionally left blank

Non-European and Other Acceptable Standards

Evidence that a vehicle complies with the standards in the table will be accepted instead of compliance with the relevant Basic IVA and IVA requirements, where evidence is provided physical inspection is not required unless there is evidence of modifications. This does not necessarily mean that these standards are equivalent to the IVA requirements, but they do guarantee a suitably high level of safety.

Mass-Produced Vehicles from USA or Canada.

To prove compliance with the listed standards, these vehicles must be fitted with a Compliance plate which will contain the name of manufacturer, 17 digit VIN number, gross vehicle weights, and the following (the FMVSS wording may vary but must include the text below):

For FVSS. *'This vehicle conforms to all applicable Federal Motor Vehicle Safety Standards in effect on the date of manufacture shown above.'*

For CMVSS: The plate will contain bilingual text (English/French) and a Transport Canada maple leaf containing a number



Such vehicles will be exempt from inspection in respect to certain sections of the manual. However, in the case of modified vehicles, especially stretch limousines, modifications to the vehicle may have invalidated the original compliance and so enquiries will need to be made of the converter, in particular whether any increase in maximum permissible weights is technically justifiable and whether the brakes have likewise been updated

Mass produced vehicles from Japan.

To prove compliance with the listed standards, a Japanese de-registration document (or equivalent, original not a copy) must be provided when the vehicle is presented for test. It must contain a Type Designation number. Such vehicles will only need to be tested to certain sections of the manual. However, in the case of modified vehicles, the original compliance may be invalidated, and this must be assessed on a case-by-case basis.

Mass produced vehicles from other territories: DVSA will update this manual from time to time with the latest information.

Non-European and Other Acceptable Standards

N1 Comparable Standards - IVA and BIVA					
Section No.	Subject area	United States (U)	Canada (C)	Japan (J)	OTHER
1	Noise	California (SAE J986) ¹	CMVSS 1106 ¹	Std accepted ¹	ADR 83/00 ¹
2	Emissions	EPA 40 CFR Part 86 or California TLEV, LEV or ULEV ⁵	CMVSS 1100 ⁵	Std accepted for vehicles registered in Japan for at least 6 months	ADR 79/01 Euro 3 (petrol & diesel) Euro 4 (diesel) ADR 79/02 Euro 4 (petrol & diesel) ADR 79/03 79/04 Euro 5 (petrol & diesel)
3	Fuel tank	FMVSS 301 FMVSS 303 – Fuel system integrity of compressed natural gas vehicles FMVSS 304 – Compressed natural gas fuel container integrity	CMVSS 301 CMVSS 301.1 – LPG fuel system integrity CMVSS 301.2 – CNG fuel system integrity	Std accepted: Japan 11-1-Art 17 – Gas fuel systems Japan 11-1-Art 17 and 11-6-27 – CNG fuel system construction requirements Hydrogen Japan 11-2-2-1-Art 20 (Hydrogen fuel system)	ADR 44/02 – Specific purpose vehicle requirements – LPG fuelled vehicles
6	Door latches	FMVSS 206	CMVSS 206	11-4-12 (door retention systems)	
8	Rear vision	FMVSS 111	CMVSS 111		
9	Braking	FMVSS 135 or FMVSS 105 + ABS on rear wheels	CMVSS 135 or CMVSS 105 +ABS on rear wheels	11-4-29 (braking systems) +ABS on rear wheels ²	ADR 35/01
10	EMC/RFI	SAE J551	SAE J551	Std accepted	
11	Diesel smoke	EPA 40 CFR Part 86 or California TLEV, LEV or ULEV	Std accepted - ref TBC	11-4-26 (10.15 mode: diesel particulate standard)	
13	Anti-theft/immobiliser	FMVSS 114	CMVSS 114	Std accepted for vehicles first registered in Japan after 01/07/2006	ADR 82/00 (immobiliser only) In conjunction with steering lock

Non-European and Other Acceptable Standards

N1 Comparable Standards - IVA and BIVA					
Section No.	Subject area	United States (U)	Canada (C)	Japan (J)	OTHER
14	Protective steering	FMVSS 203 FMVSS 204	CMVSS 203 CMVSS 204	11-4-1 (steering system impact) (J3)	ADR 69/00 (plus driver's airbag) or ADR 73/00
15	Seat strength (+ head rests)	FMVSS 207	CMVSS 207	11-4-8 (seats and seat anchorages) (J1)	
17	Speedometer /reverse	FMVSS 101 Excluding reverse gear	CMVSS 101 Excluding reverse gear		
19	Seat belt anchorage	FMVSS 210 including associated requirements of FMVSS 207 and 208	CMVSS 210 including associated requirements of CMVSS 207 and 208	11-4-10 (seat belt anchorages)	ADR 5/04 and ADR 69/00
25	Headlamps (in respect of LED & HID Lumens)	Std accepted ³	Std accepted ³	Std accepted ³	ADR- Std accepted ³ Also, see Footnote ⁴ below
31 a	Seat belts components	FMVSS 209	CMVSS 209	Std accepted	
31 b	Installation of seat belts	FMVSS 208	CMVSS 208	Std accepted	
33	ID of Controls	FMVSS 101	CMVSS 101		
34	Defrost/Demist	FMVSS 103	CMVSS 103	11-4-33 (defrosting and demisting systems)	
35	Wash/Wipe	FMVSS 104	CMVSS 104	Std accepted	
38	Head restraints (see item 15)	FMVSS 202	CMVSS 202	Std accepted	
39	Fuel consumption				ADR 81/01
41	Heavy Duty diesel gaseous emissions	Std accepted	Std accepted	Std accepted for vehicles registered in J for at least 6 months	

Non-European and Other Acceptable Standards

N1 Comparable Standards - IVA and BIVA					
Section No.	Subject area	United States (U)	Canada (C)	Japan (J)	OTHER
45	Glass	FMVSS 205 (U1)	CMVSS 205 (C1)	11-4-21 (window glass) JIS R3211	South Africa SABS 1191 SABS 1193 India IS2553 (Part 2) 1992 (Note 11) Australia AS/NZS 2080 AS/NZS 2080T (Note A1)
46	Tyres	FMVSS 109 (U2) FMVSS 110 (U3) FMVSS 119/120 FMVSS 139	CMVSS 110 (C3) CMVSS 119/120 CMVSS 139	JIS D4201 (marking) JIS D4202 (dimensions) JIS D4230 (performance)	
50	Couplings <i>(if fitted)</i>				
53	Frontal Impact (if <2500kg GVM)	FMVSS 208	CMVSS 208	Std accepted	ADR 73/00
54	Side impact (if <700mm R point)	FMVSS 214	CMVSS 214	Std accepted	ADR 72/00
60	Frontal protection systems <i>(if fitted)</i>				
69	Electrical Safety	FMVSS 305 (U4)	CMVSS 305 (U4)	Std Accepted	See Footnote ⁴ below

This information is provided for guidance only and DVSA retains the right to test the vehicle against the IVA requirements if they have any reason to doubt compliance with the indicated standard.

(U) FMVSS = Federal Motor Vehicle Safety Standards

(C) CMVSS = Canadian Motor Vehicle Safety Standards

SAE = Society of Automotive Engineers (standard)

EPA 40 CFR = Environmental Protection Agency, Code of Federal Regulation, Title 40

ADR = Australian Design Rules

Non-European and Other Acceptable Standards

(J) The references 11-4-(digit) are the relevant sections of the Automotive Type Approval Handbook for Japanese Certification published by the Japan Automobile Standards International Centre in the respective years listed (1997).

JIS Japanese Industrial Standard.

(A1) Does not include opacity. Must display manufacturer's name or trademark. Windscreen to show 2080 and WHP. Other windows 2080T and CHT, L, LT, LCHT or HP.

(A2) Vehicles having a date of manufacture pre- 1/10/96

(A3) Vehicles having a date of manufacture from 1/10/96

(I1) Does not include opacity. Must display manufacturer's name or trademark. Windscreen to show Z or LW. Other windows T, TW, Z, L or LW.

(J1) Does not address location of unlocking controls or automatic locking of seats.

(J2) Other areas are not addressed.

(J3) Only addresses steering wheel/column energy absorption requirement of paragraph 3.

(J4) Does not confirm compliance in respect of longitudinal brake distribution.

(U1) and **(C1)** Glass bearing the following marking complies with FMVSS 205 and CMVSS 205

- in the case of a windscreen – AS1 or AS10
- in the case of a window wholly or partly on either side of the driver's seat – AS1, AS2, AS10, AS11A
- in any other case – AS1, AS2, AS3, AS10, AS11A, AS14, AS15, AS16.

(U2) Tyre speed capability may not be sufficient. It must be no less than the vehicle design speed (or fixed speed limiter speed, where fitted).

(U3) and **(C3)** Non-pneumatic spare tyres are illegal for use in Great Britain. FMVSS and CMVSS are not considered acceptable for space-saver spare tyres.

(U4) FMVSS 305 is not acceptable if the traction batteries are of the lead acid type.

Non-European and Other Acceptable Standards

Footnotes

- 1 If there is evidence to suggest that the manufacturer's original exhaust equipment has been modified, i.e.: evidence of a physical change or being louder than expected, then a noise test appropriate to the level of inspection (Basic/Normal) must be carried out to prove that the vehicle meets the requirements.
- 2 For vehicles without ABS on rear wheels we will have to carry out a brake distribution test as shown in 09E Basic IVA (Japanese pre 2004 vehicles having a deregistration document).
- 3 **US Standard:** Evidence of FMVSS plate affixed to the vehicle, plus headlamp aim test.
Canadian Standards: Evidence of CMVSS plate affixed to the vehicle, plus headlamp aim test.
Japanese Approval Standard: Evidence of type specification/classification numbers on the export certificate or from the manufacturer.
Australian Design Rules Standard (ADR): Evidence from original manufacturer's plate.
- 4 Applications for an unmodified mass-produced vehicle meeting the "Personal Import" class, imported from:
 - Australia
 - New Zealand
 - Singapore
 - Hong Kongwill also be considered compliant with the requirements of UNECE Regulation 48 and UNECE Regulation 100.
- 5 For all vehicles displaying a FMVSS or CMVSS plate, a metered test must be performed irrespective of whether a 'Vehicle Emission Control Information' (emissions) plate is attached to the vehicle.

Note: Even though we accept the comparable standard for the relevant Basic IVA and IVA sections, we still have to carry out a condition check where necessary.

Record of Revision

Revision	Date	Description of Change
1	18/04/2011	Version 1
2	31/10/2011	Japanese standards sections 1, 2, 3, 10, 31, 35, 38 & 41 now confirmed as acceptable (TBC removed)
3	05/10/2015	Update Section 2 (Other) ADR/Euro V, Insert ADR + Australian Standard, braking ADR corrected DVSA replaces VOSA
4	03/04/2018	Correct Euro numbers in Section 2 Other (light duty numbers).
5	01/09/2020	Further clarification regarding USA/CDN spare tyre acceptability.
6	01/04/2022	FMVSS 305 acceptable as alternative to UN Reg 100 except where traction batteries are lead acid. Clarification of FMVSS statement.
7	22/05/2023	Update table Section 3 (Fuel Tanks) to include acceptance of Japanese Standard for Hydrogen. Addition of CMVSS 305 as acceptable alternative to UN Reg 100.01 except where traction batteries are lead acid. Addition of Section No. 25 to table and associated footnotes.
8	09/10/2024	All Footnotes to table renumbered. Add Footnote 1 to Table referenced from 01 Noise (all) relating to a noise test requirement & Add Footnote 5 to Table referenced from 02 Emissions (US & Canada) relating to a metered test requirement (TSE IVA N1 ONE 004). Footnote 3 amended to include Australia, & UNECE Regulation 100, & add reference to Footnote 3 for 69 Electrical Safety from 'Other' column. (IVA N1 ONE 007).

This page intentionally left blank

IVA Manual with Basic Requirements

Where a vehicle subject to The Basic IVA Inspection is accompanied by voluntary documentary evidence, the examiner must be satisfied that such evidence fully satisfies the IVA requirements relating to the vehicle **as presented**. In cases where the evidence is unsatisfactory the procedures and standards for that section or area must be fully applied.

Record of Revision

Revision	Date	Description of Change
1	18/04/2011	Version 1

01 Noise

Application: Vehicles subject to Basic requirements

Method of Inspection	Required Standard
<p>This inspection applies to the exhaust system fitted to the engine which provides the motive power for the vehicle.</p> <p>Conversions that are not based on N1 vehicles may comply with the applicable requirements of the original base vehicle.</p> <p>Documentary evidence of base or incomplete vehicle approvals will be deemed acceptable.</p> <p>Using sound level meter to the manufacturer's instructions, carry out a stationary noise check.</p> <p>Position the vehicle within the authorised test area. With the sound meter horizontal, set the microphone height so that it is at the height of the exhaust outlet or 200mm from the ground, whichever is higher.</p> <ol style="list-style-type: none"> a. At an angle of 45 degrees to the exhaust outlet in the direction which gives the greatest distance between it and the vehicle contour b. At a distance of 500mm from the exhaust outlet. <p>With the vehicle at normal operating temperature, run the engine at $\frac{3}{4}$ of its 'maximum power' speed, and note the sound level reading obtained.</p> <p>Note 1: Manufacturers drain holes are permitted in silencers</p>	<p>Exhaust Systems</p> <ol style="list-style-type: none"> 1. Must be securely mounted. 2. Must have all components secure. 3. Must not leak (see Note 1). 4. Must be fitted with a silencer. 5. Must have a measured sound level not exceeding 99dbA (see Notes 2 & 3).

Method of Inspection	Required Standard
<p>Note 2: The exhaust may have several outlets up to 300mm apart connected to the same silencer. In this instance the microphone must face the outlet closest to the vehicle contour or highest from the ground. In all other cases, separate measurements must be taken for each exhaust outlet; the highest value obtained is the test value.</p> <p>Note 3: Where the engine maximum power speed is not available, the test may be carried out at 2/3 of engine maximum design speed.</p>	

Record of Revision

Revision	Date	Description of Change
1	18/04/2011	Version 1
2	01/09/2020	Link RS 5 to Notes 2 & 3.

This page intentionally left blank

02A Visual Emissions

Application: Vehicles subject to Basic requirements fitted with a Spark Ignition Engine

Method of Inspection	Required Standard
<p>All vehicles Raise the engine speed to around 2500rpm or half the maximum engine speed if this is lower. Hold this speed steady for 20 seconds to ensure that the inlet and exhaust system is properly purged. Allow the engine to return to idle and the emissions to stabilise.</p> <ul style="list-style-type: none">• Assess the engine idle speed.• Assess the smoke emitted from the tailpipe at idle.• Rapidly increase the engine speed to around 2500rpm or half maximum engine speed if this is lower and assess the smoke emitted from the tailpipe. Allow the engine to return to idle.	<ol style="list-style-type: none">1. The engine must be idling at its normal idling speed.2. The exhaust must not emit dense blue or clearly visible black smoke for a continuous period of 5 seconds at idle speed.3. The exhaust must not emit excessive smoke or vapour of any colour during acceleration which would obscure the view of other road users.

Record of Revision

Revision	Date	Description of Change
1	18/04/2011	Version 1

02B Metered Emissions

Application: Vehicles subject to Basic requirements

Method of Inspection	Required Standard
<p>When checking the exhaust emissions, the engine must be at its normal idle speed and normal operating temperature. Engine speed and temperature can be assessed either subjectively or by reference to manufacturer’s or other reliable data.</p> <p>Vehicles fitted with a spark ignition except:</p> <ul style="list-style-type: none"> • Vehicles with an effective date Pre 1975 • a rotary engine vehicle having an effective date before 1 August 1987. • a 2 stroke engine vehicle • vehicles fuelled by CNG (Compressed Natural Gas) in respect of the requirement to check Hydrocarbons <p>In the case of a completed vehicle, the requirements according to the category and date of completion of the base or incomplete vehicle based on maximum mass may apply. Documentary evidence of base or incomplete vehicle approvals will be deemed acceptable, Modification to the exhaust system length after the rear silencer will be permissible without further test.</p> <p>In the case of Armoured vehicles exemption from any requirement of this section is permitted if it can be demonstrated to the satisfaction of the Approval Authority that it is impossible for the vehicle to comply due to its special purpose.</p> <p>Check that the analyser probe can be inserted into the tailpipe. Use a suitable exhaust gas analyser to determine the proportions of carbon monoxide (CO) and hydrocarbons (HC) in the exhaust gas over a period of at least 5 seconds at idle. For vehicles with multiple tailpipes linked to separate exhaust systems an average reading should be calculated.</p>	<ol style="list-style-type: none"> 1. There must be access to the exhaust tailpipe(s) to allow the insertion of the analyser probe. 2. The exhaust gas must not contain carbon monoxide content exceeding the limit for a continuous period of 5 seconds 3. The exhaust gas must not contain hydrocarbon content exceeding the limit for a continuous period of 5 seconds. 4. The emissions limits must be met as prescribed in the flow charts below for CAT1 or CAT2.

Metered Emissions 02B

Method of Inspection	Required Standard
<p>Note: If a vehicle meets the CO requirement at its normal idling speed but fails the HC check, re-check the HC level at a high idle speed of 2000rpm. If the HC reading is then 1200ppm or less, the vehicle will meet both the CO and HC requirements.</p> <p>Note: In the case of a dual fuelled vehicle where the petrol fuel tank has a capacity of less than 15 litres there is no requirement to check the emissions with the engine running on petrol. A dual fuelled vehicle is defined as a vehicle that can be fuelled with both petrol and gaseous fuel.</p>	

Method of Inspection	Required Standard
Check that the analyser probe can be inserted into the tailpipe If the vehicle fails the BET Test then; Carry out a CAT1 or CAT 2 Test	

Carry out the test using the flowchart.

Ensure that the engine is hot by checking for example temperature gauge, cooling fan cut-in or hot coolant hoses. If the engine is not at normal temperature raise the engine speed to between 2000 and 3000rpm and maintain this speed until normal temperature has been reached.

Attach engine speed measuring device. It is permissible for the purposes of this check to use the vehicle tachometer.

Ensure the engine is idling normally.

Perform a HC hang-up check and ensure that HC<20ppm before continuing. Insert the analyser sample probe.

Fast idle test: Raise the engine speed to a fast idle between 2500 and 3000rpm and hold steady. Note the readings for CO, HC, and lambda, and record the results.

Idle test: Allow the engine to idle. Note the CO reading and record the result.

Remove analyser sample probe.

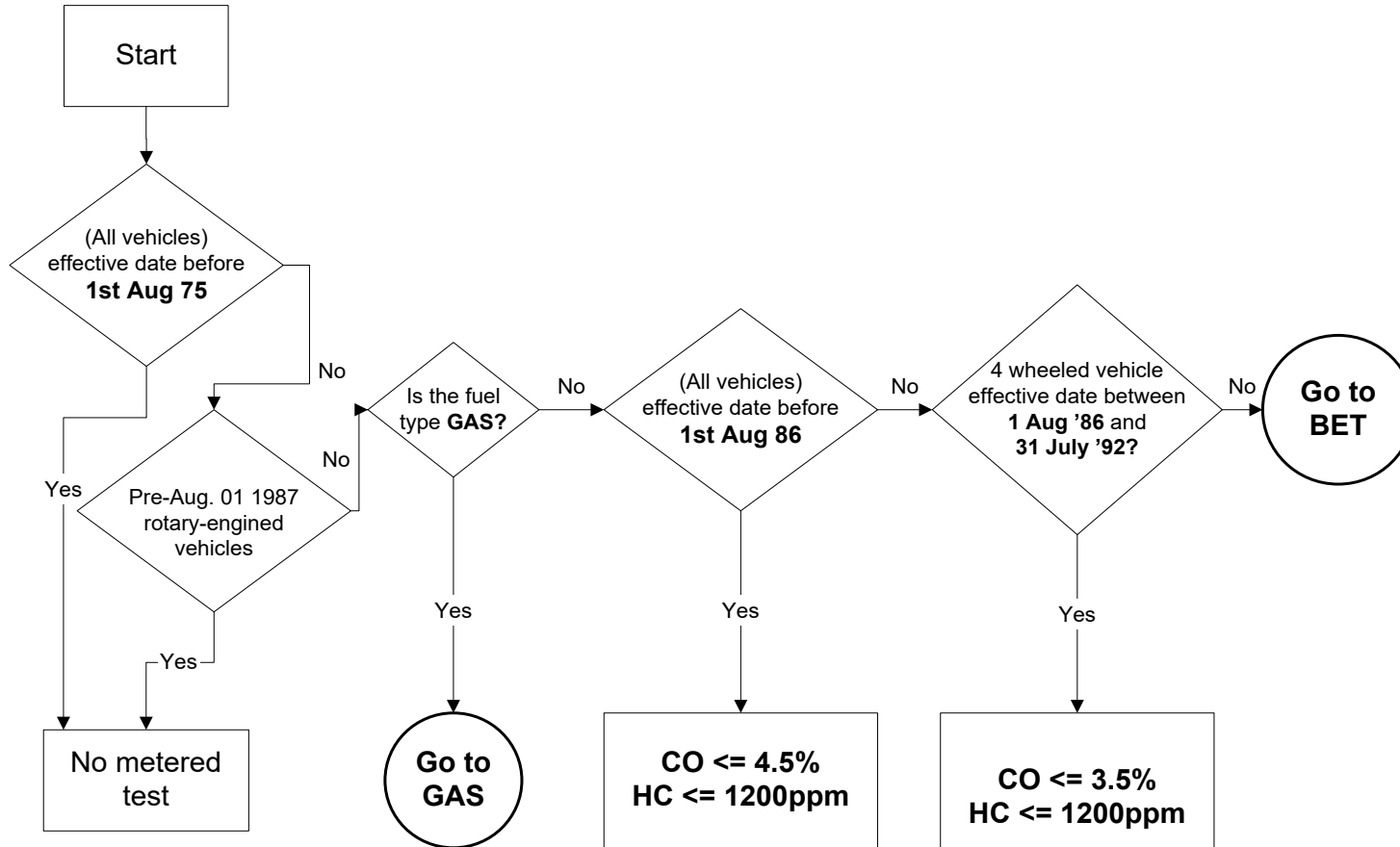

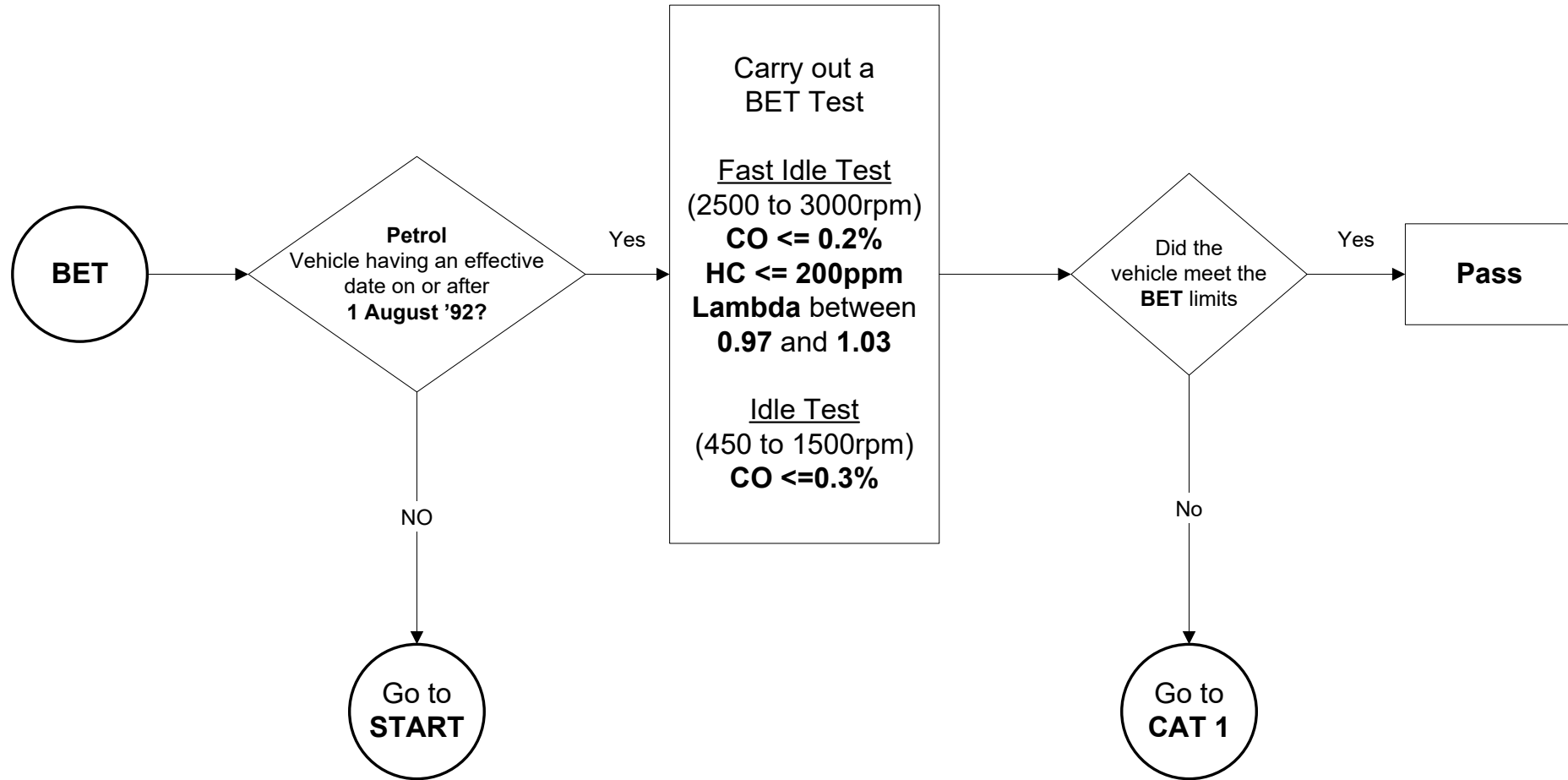

All vehicles fitted with a spark ignition engine except

- a. vehicles fuelled by LPG or CNG (liquid petroleum gas or compressed natural gas) in respect of the requirement to check the value of lambda.
- b. vehicles fuelled by CNG in respect of the requirement to check Hydrocarbons.
- c. vehicles fuelled by LPG or CNG having an effective date in the case of a “passenger car” from 1 August 1992 30 September 1999
 - in the case of another four or more wheeled vehicle from 1 August 1994 - 30 September 1999 to which the requirements apply when running on LPG/CNG as if the vehicle had an effective date of 1 August 1986 (i.e., non-catalyst test).
- d. vehicles that are listed in the current edition of the “In Service Exhaust Emission Standards for Road Vehicles” publication that are
 - passenger cars having an effective date from 1 August 1992 - 31 July 1995
 - other four or more wheeled vehicles having an effective date from 1 August 1992 - 31 July 1997

Identify the vehicle specific test limits using the flow charts

Connect the engine speed measuring device and insert the engine oil temperature measuring probe into the dipstick hole

Engine pre-conditioning: Check the engine oil temperature. If it is below the minimum vehicle specific requirement, raise the engine speed to between 2000 and 3000rpm and maintain this speed until the minimum engine oil temperature has been reached. Remove temperature measuring probe and replace dipstick.

Perform a HC hang-up check and ensure that $HC < 20\text{ppm}$ before continuing. Insert the analyser sample probe.

1st Fast Idle Test: Raise the engine speed to the vehicle specific fast idle speed and maintain for 30 seconds. If the engine speed drifts outside the fast idle speed range, begin the 30 second countdown again. During the last 5 seconds note the readings for CO, HC, and lambda, and record the results.

If the vehicle has passed the first fast idle test, then go to Idle Test otherwise go to Additional Engine Pre-conditioning.

Additional engine pre-conditioning: Run the engine between 2000-3000rpm for 3 minutes or until all the emissions are within limits. If the engine speed goes outside the fast idle range, then freeze the countdown until the rpm is once again within the prescribed limits.

Metered Emissions 02B

Catalyst stabilisation: Raise the engine speed to the vehicle specific fast idle speed and maintain for 30 seconds. If the engine speed drifts outside the fast idle speed range then begin the 30 second countdown again.

Idle test: Allow the engine to idle during a 30 second countdown. During the last 5 seconds, note the CO reading and record the result I. Remove analyser sample probe and engine speed measuring device.

Notes:

When to do the test

It is recommended that the extended test is carried out as soon as possible after the BET. This allows the test to be carried out on a fully warmed up engine.

Working environment

To prevent the build-up of fumes, the test should be carried out in a well-ventilated area.

Gas analyser probe

It is important to ensure that the gas analyser probe is inserted as fully as possible into the exhaust tail-pipe and is secure.

Cosmetic engine covers: Where engine speed can only be measured by the removal of a cosmetic engine cover, the engine speed must be measured if the cover can be easily un-clipped. Otherwise, engine speed measurement may be by-passed.

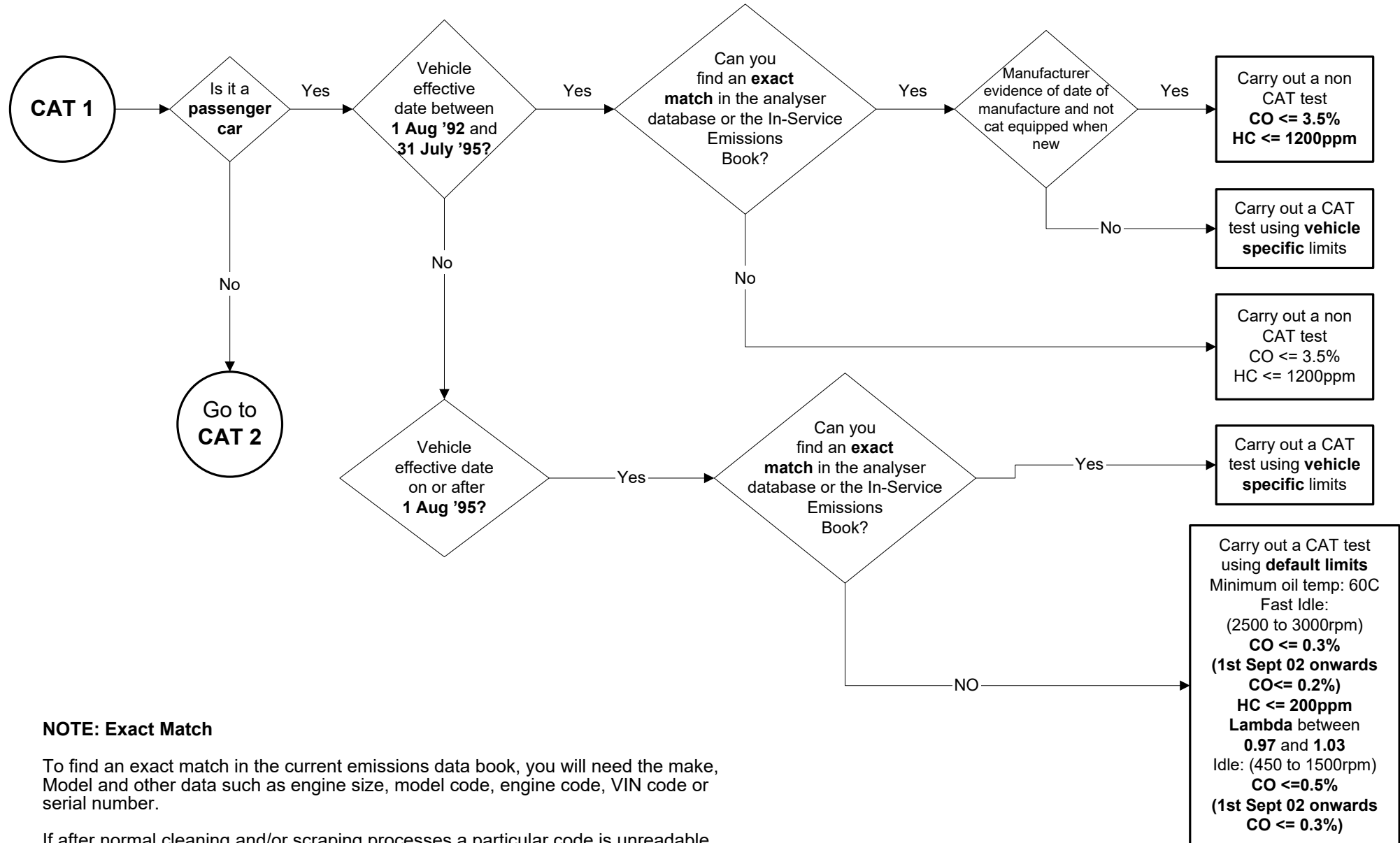

NOTE: Exact Match

To find an exact match in the current emissions data book, you will need the make, Model and other data such as engine size, model code, engine code, VIN code or serial number.

If after normal cleaning and/or scraping processes a particular code is unreadable or inaccessible, carry out as if no exact match can be found.

Metered Emissions 02B

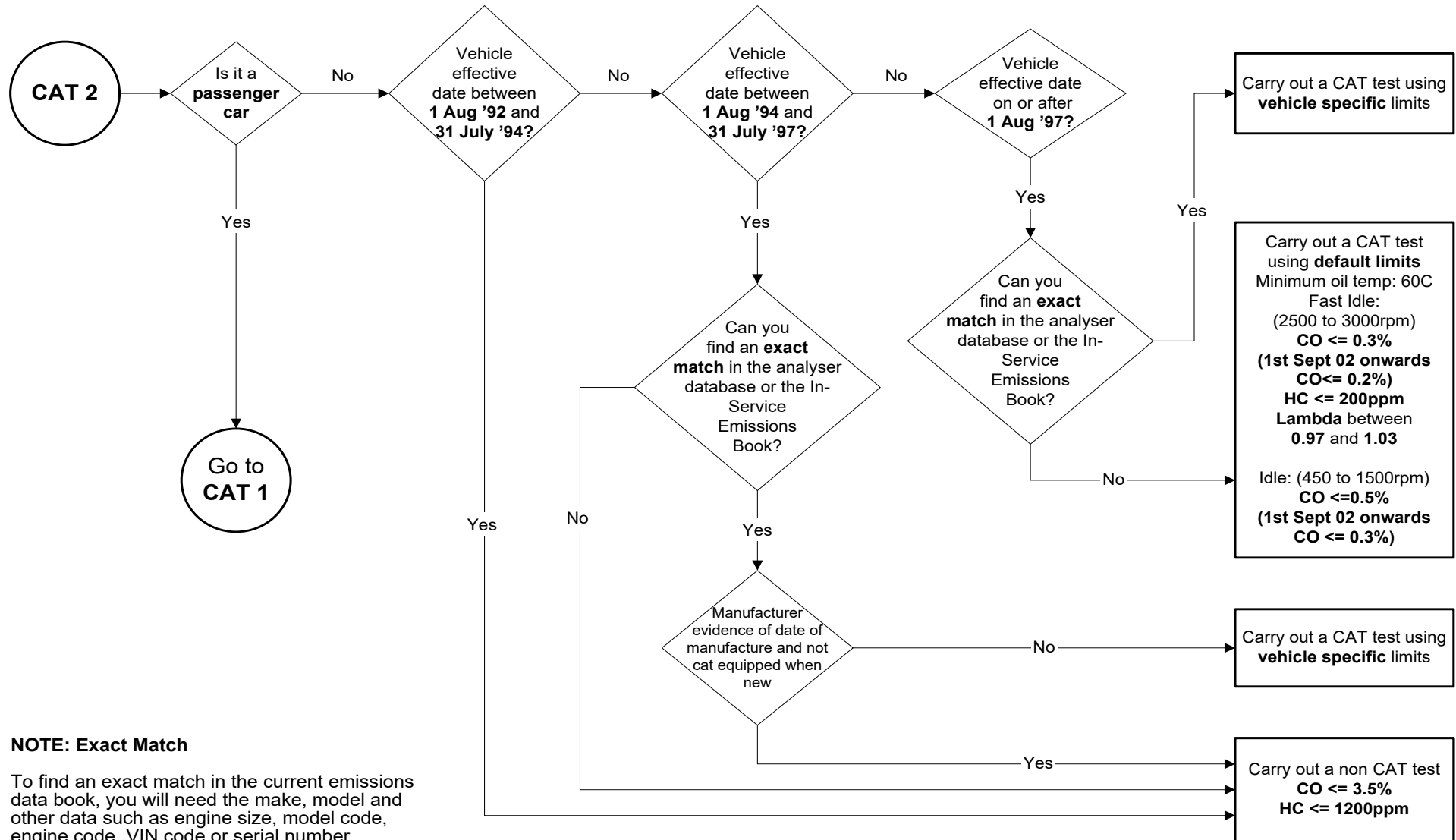

NOTE: Exact Match

To find an exact match in the current emissions data book, you will need the make, model and other data such as engine size, model code, engine code, VIN code or serial number.

If after normal cleaning and/or scraping processes a particular code is unreadable or inaccessible, carry out as if no exact match can be found.

Metered Emissions 02B

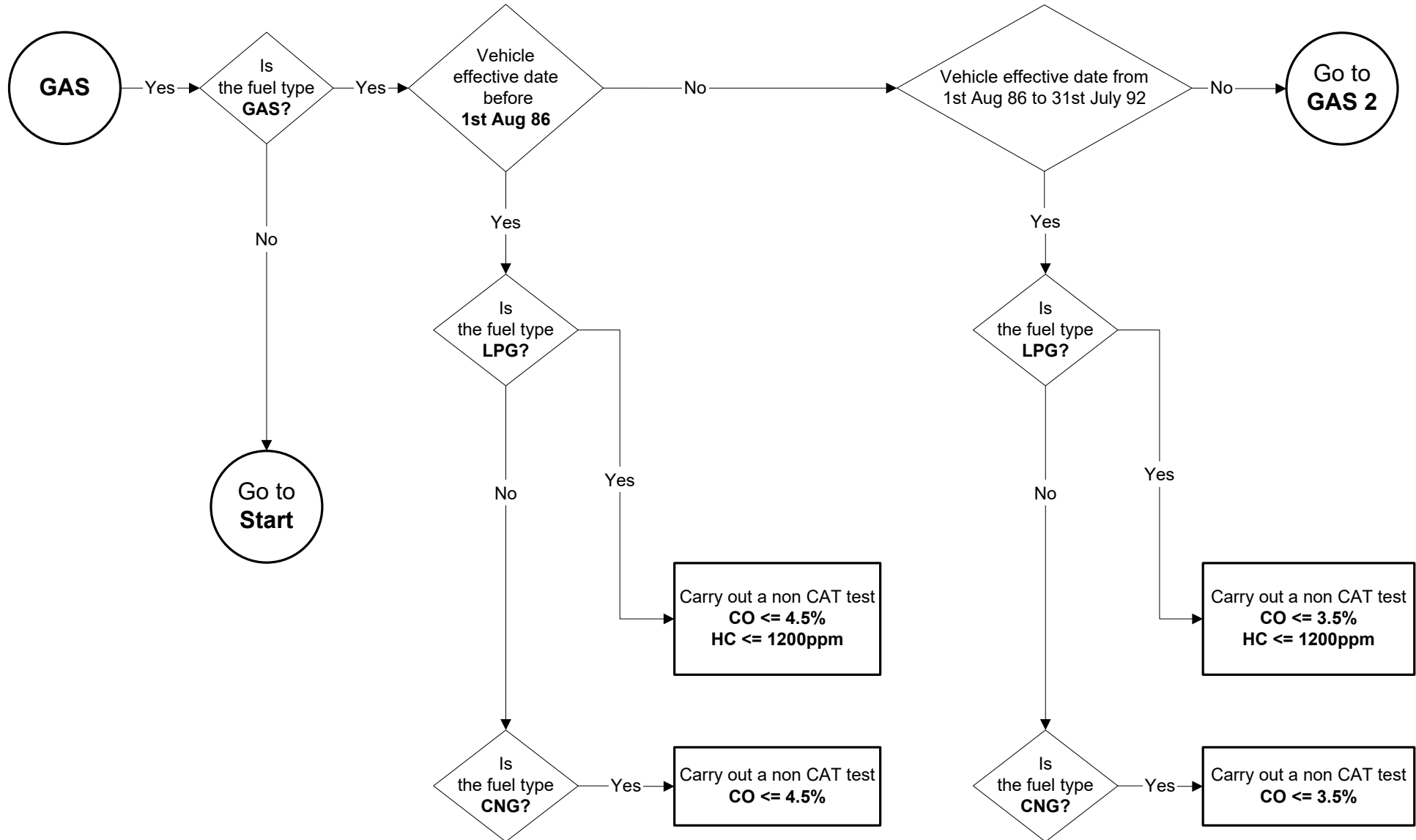

Metered Emissions 02B

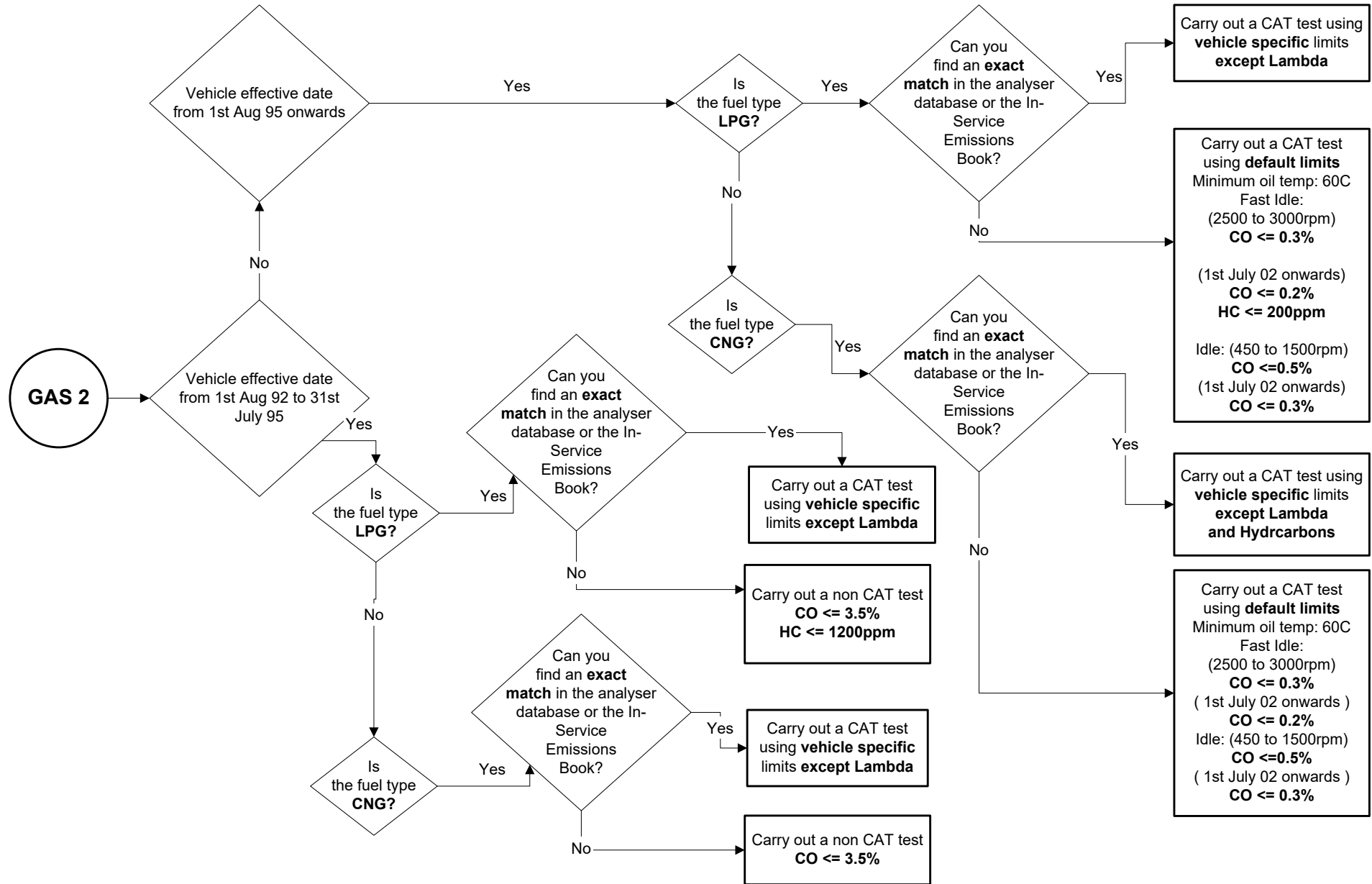

Metered Emissions 02B

“Effective Date”

The “effective date” used to determine the criteria applicable is - the date of manufacture of the vehicle, except for an “Amateur Built” vehicle, a “Vehicle manufactured using parts of a registered vehicle” or a “Rebuilt vehicle” it shall be 1 January immediately preceding the date of manufacture of the vehicle’s engine if this is earlier.

If the “effective date” cannot be determined, it must be assumed to be on or after 1 August 1997.

Automatic transmission

When testing vehicles fitted with automatic transmission care must be taken to avoid overheating the transmission system. Do not carry out unnecessary engine acceleration or prolonged high revving of the engine. Reference to vehicle manufacturer’s instructions may be necessary.

“Passenger car”

means a motor vehicle which

- (a) is constructed or adapted for use for the carriage of passengers and is not a goods vehicle;
- (b) has no more than five seats in addition to the driver's seat; and
- (c) has a weight not exceeding 2,500 kg maximum gross;

Record of Revision

Revision	Date	Description of Change
1	18/04/2011	Version 1
2	31/07/2011	Correct 1st flowchart reference to Pre-87 Rotary-engined vehicles
3	31/05/2012	Insert new note – petrol tanks capacity less than 15 litres
4	03/04/18	Reposition RS 4 & 5, amend final note in MOI.
5	01/07/2018	RS4 deleted (duplicate of RS1) RS5 renumbered.
6	01/09/2020	MOI para 2 clarified.

This page intentionally left blank

02C Diesel Emissions

Application: Vehicles subject to Basic requirements

Method of Inspection	Required Standard																			
<p>Where possible check that:</p> <ul style="list-style-type: none"> • there is sufficient oil in the engine, • the oil pressure is not too low, • the camshaft belt is in a satisfactory condition, • there is no abnormal engine noise, • the governor has not been tampered with, • the engine is at normal operating temperature, <p>Raise the engine speed to around 2500rpm, or half the maximum engine speed if this is lower and hold for 30 seconds to fully purge the inlet and exhaust system.</p> <p>Raise the engine speed slowly to maximum to check the operation of the governor. Once the engine speed has stabilised or if it becomes clear that the governor is not working, release the pedal, return to idle and stop the engine.</p> <ol style="list-style-type: none"> a. Prompt the meter to carry out a zero check. b. Check that the smoke meter probe can be inserted into the tailpipe. c. Insert the probe fully and securely, in line with the gas flow. Restart the engine. <p>Fast Pass</p> <p>Following the meter prompts, depress the accelerator pedal quickly and continuously but not violently, to reach full fuel position in less than 1 second.</p>	<ol style="list-style-type: none"> 1. There must be access to the exhaust tailpipe(s) to allow the insertion of the analyser probe. 2. The measured emissions must not exceed the limits, as shown in the table below <table border="1" data-bbox="1182 612 2107 927"> <thead> <tr> <th data-bbox="1182 612 1435 651">Engine</th> <th colspan="3" data-bbox="1435 612 2107 651">Effective Date</th> </tr> <tr> <td data-bbox="1182 651 1435 715"></td> <th data-bbox="1435 651 1630 715">Before 1st July 08</th> <th data-bbox="1630 651 1839 715">1st July 08 onwards</th> <th data-bbox="1839 651 2107 715">1st September 18 onwards</th> </tr> </thead> <tbody> <tr> <td data-bbox="1182 715 1435 788">turbocharged engine</td> <td data-bbox="1435 715 1630 788">3.00m⁻¹</td> <td data-bbox="1630 715 1839 788">1.50m⁻¹</td> <td data-bbox="1839 715 2107 788">0.7m⁻¹ or plate value if lower</td> </tr> <tr> <td data-bbox="1182 788 1435 927">non-turbocharged engine</td> <td data-bbox="1435 788 1630 927">2.50m⁻¹</td> <td data-bbox="1630 788 1839 927">1.50m⁻¹</td> <td data-bbox="1839 788 2107 927">0.7m⁻¹ or plate value if lower (see Note 1)</td> </tr> </tbody> </table> <ol style="list-style-type: none"> 3. The exhaust must not emit excessive smoke or vapour of any colour to an extent likely to obscure the vision of other road users. 				Engine	Effective Date				Before 1 st July 08	1 st July 08 onwards	1 st September 18 onwards	turbocharged engine	3.00m ⁻¹	1.50m ⁻¹	0.7m ⁻¹ or plate value if lower	non-turbocharged engine	2.50m ⁻¹	1.50m ⁻¹	0.7m ⁻¹ or plate value if lower (see Note 1)
Engine	Effective Date																			
	Before 1 st July 08	1 st July 08 onwards	1 st September 18 onwards																	
turbocharged engine	3.00m ⁻¹	1.50m ⁻¹	0.7m ⁻¹ or plate value if lower																	
non-turbocharged engine	2.50m ⁻¹	1.50m ⁻¹	0.7m ⁻¹ or plate value if lower (see Note 1)																	

Diesel Emissions 02C

Method of Inspection	Required Standard
<p>Hold it there until a release prompt is given, then immediately release the pedal. Allow the engine, and any turbocharger fitted, to return to idle speed. At the end of the 1st acceleration read the smoke level displayed on the meter. If it is at or below the limit for the vehicle has passed this part of the test and a pass result will be displayed on the meter.</p> <p>If the 1st acceleration smoke level is greater than the limit carry out two further accelerations following the meter prompts.</p> <p>At the end of the 3rd acceleration, read the mean smoke level displayed on the meter. If it is at or below the appropriate limit, the vehicle has passed this part of the test, and a pass result will be displayed on the meter.</p> <p>If the mean smoke level is too high, carry out further accelerations up to a maximum of 6 in total.</p> <p>After each acceleration, check the mean reading. This part of the test is complete when either:</p> <ol style="list-style-type: none"> 1. the mean of any 3 consecutive smoke readings is at or below the appropriate limit, 2. six accelerations have been performed. <p>Assess whether the smoke emitted from the exhaust, regardless of measured density, is likely to obscure the vision of other road users.</p> <p>For vehicles with multiple tailpipes linked to separate exhaust systems an average reading should be calculated.</p> <p>Note 1: Plate value means the co-efficient of absorption (m^{-1}) shown on a statutory plate or another plate provided for this purpose.</p> <p>Conversions that are not based on N1 vehicles may comply with the applicable requirements of the original base vehicle. Documentary evidence of base or incomplete vehicle approvals will be deemed acceptable, Modification(s) to the exhaust system length after the rear silencer(s) are permissible without further test</p>	

Reasons for not carrying out a smoke test.

Do not carry out a smoke test if the engine is not in a safe condition to do so. This will involve questioning the vehicle presenter and a brief examination of the engine condition. A smoke test must not be carried out if the oil temperature is below 60°C. The reason for not conducting a smoke test must be clearly recorded on the Notification of Refusal (IVA30).

Record of Revision

Revision	Date	Description of Change
1	18/04/2011	Version 1
2	01/07/2018	New limits effective from 01 Sep 18, MOI amended, new Note 1.

03A Fuel Tanks

Application: All Vehicles

Method of Inspection	Required Standard
<p>This inspection is to ensure that all fuel tanks used to store fuel for the propulsion of the vehicle are suitable for their intended use. Considering the type of fuel used, the fuel system, including the fuel tank shall be so designed, constructed, and fitted as to withstand the forces, vibration, and corrosive environment to which it is likely to be subject. It shall also be so fitted as to avoid the risk of damage such as abrasion due to fouling of other parts, and to minimise the risk of fire in the event of any leakage of fuel.</p> <p>Note 1: Fuel Tanks for Gaseous Fuels Check that an Approval / Test Report is presented with the vehicle and that there appears to be no modifications that would invalidate the evidence.</p> <p>The required standard for Gaseous Fuels: UNECE 67.01 – LPG fuel systems. Or UNECE 115.00 – Retrofit LPG fuel systems</p> <ul style="list-style-type: none"> • Requires compliance with the installation requirements of UNECE 67.01. or <p>An Installation Certificate from an Approved Installation Engineer, or</p> <p>A Comparable Standard for LPG UNECE 110.00 – CNG fuel systems, or</p> <p>UNECE 115.00 – Retrofit CNG fuel systems</p> <ul style="list-style-type: none"> • Requires compliance with the installation requirements of UNECE 110.00., or 	<p>Fuel Tanks for Gaseous Fuels</p> <ol style="list-style-type: none"> 1. The vehicle as presented must be accompanied by satisfactory documentary evidence with the required standard for fuel tanks for gaseous fuels (see Note 1). <p>Plastic Fuel Tanks for Liquid fuels</p> <ol style="list-style-type: none"> 2. The vehicle must be accompanied by satisfactory evidence that the tank is designed for road use, or the tank is an original fitment to a mass-produced vehicle or has been previously and is un-modified (see Note 2). <p>Fuel Tanks for Liquid fuels at Ambient Temperature</p> <ol style="list-style-type: none"> 3. A fuel tank and associated equipment must not leak. 4. All fuel related components must be securely mounted. 5. All metal fuel tanks must have an earth path to prevent the build-up of static electricity (this may be a separate bonding or the mounting arrangement where it does not electrically isolate the tank). 6. A fuel tank must be constructed to withstand the environment, forces, and vibration it is likely to be subjected to during normal use. 7. A fuel tank must not be fouled by moving parts of the vehicle or mounted so that it is likely to be subject to abrasion by adjacent parts.

Fuel Tanks 03A

Method of Inspection	Required Standard
<p>An Installation Certificate from an Approved Installation Engineer, or</p> <p>A Comparable Standard for CNG Check that an Approval / Test Report is presented with the vehicle and that there appears to be no modifications that would invalidate the evidence.</p> <p>Note 2: Plastic Fuel Tanks Check that the fuel tank:</p> <ul style="list-style-type: none"> • Is unmodified and an original fitment in the case of a mass-produced vehicle or • Appears to have previously been fitted to a mass-produced vehicle or • Is accompanied by satisfactory evidence provided by the tank manufacturer or approval authority showing that it has been manufactured and tested to meet the standards required for road use. <p>Fuel Tanks for Liquid Fuels at Ambient Temperature including Additional or Alternative Fuel Tanks. RS 3 - 16 Check the installation of the fuel tank and fuel system components to ensure compliance with the standards.</p> <p>Note 3: Hydrogen fuelled vehicles Check that an Approval / Test Report is presented with the vehicle and that there appears to be no modifications that would invalidate the evidence of compliance with the technical provisions of either:</p> <p>Regulation (EC) 79/2009, or</p> <p>UNECE Regulation 134.</p>	<ol style="list-style-type: none"> 8. Fuel tanks must not be positioned near a heat source (similar in installation to that of a type approved vehicle), so that a leak could cause a fire hazard. 9. Fuel tanks must be positioned so as not to be vulnerable to damage from protruding parts or sharp edges in the event of an impact. 10. The fuel tank must be positioned so that in the event of a leak the fuel could not accumulate or find a path to the passenger compartment. (if fitted in a compartment there must be a drain which does not exit onto a heat source) 11. A fuel tank must not be in, or form part of the passenger compartment, or other compartment integral with it, and the bulkhead that separates the passengers from the fuel tank must be free from holes through which any escaped fuel could travel. 12. The fuel tank must be fitted with a vent (to permit release of a pressure build up) which does not exit onto the exhaust or into the vehicle or be situated at such a height that fuel would be likely to leak when the vehicle is driven. 13. Any fuel filler neck or vent must not allow spilt fuel to be able to fall onto the exhaust system. 14. Fuel tank filling points must not be in the passenger compartment, luggage compartment or within an engine compartment. 15. A fuel filler cap must positively locate to the filler neck and incorporate an adequate sealing arrangement so that a fuel leak is not possible. 16. The fuel filler cap must either be, tethered to the vehicle, or be of a lockable type where the key can only be removed when the cap is locked, or an automatically opening and closing fixed filler cap (Post 05 / 2009 vehicles only).

Fuel Tanks 03A

Method of Inspection	Required Standard
	<p data-bbox="1048 204 1413 233">Hydrogen fuelled vehicles</p> <p data-bbox="1099 272 2029 368">17. The vehicle as presented must be accompanied by satisfactory documentary evidence for Hydrogen fuel systems (including storage tanks) (see Note 3).</p>

Record of Revision

Revision	Date	Description of Change
1	18/04/2011	Version 1
2	31/07/2011	Inserted new Note 2 regarding plastic fuel tanks
3	01/07/2018	Add requirements for hydrogen fuel tanks.
4	22/05/2023	Removal of reference to outdated Regulations/Directives; Revision of RS17 & Note 3 to include Hydrogen fuel systems. (TSE N1 03A 003)
5	09/10/2024	Note 3 revised.

04 Rear Registration Plate Space

Application: All Vehicles

Method of Inspection	Required Standard																
<p>With an IVA Test plate of the required size placed onto the space provided, check that it is visible and can be easily read from a height of 1.5m from all places along a 21.5m line on the ground placed at 10.75m behind and parallel to the rear of the vehicle.</p> <p>In the case of unmodified Mass Produced vehicles, the standards in this section shall be considered to be met.</p> <p>Where evidence suggests that the vehicle has been modified, the examiner shall assess whether the modification would be likely to materially affect the performance of the relevant component or system, and if so, carry out assessment against the RS.</p> <p>Note 1: Only Mass Produced vehicles manufactured for the non-European markets may comply with the small space.</p> <p>Note 2: A plate hanging from the vehicle with no structure or support brackets behind it would be considered unacceptable</p>	<p>1. All vehicles must comply with one of the registration plate spaces, shown in the table below (see Note 1).</p> <table border="1" data-bbox="1113 478 2056 651"> <thead> <tr> <th></th> <th></th> <th>Minimum Width (mm)</th> <th>Minimum Height (mm)</th> </tr> </thead> <tbody> <tr> <td>Euro space</td> <td>Option 1</td> <td>520</td> <td>120</td> </tr> <tr> <td></td> <td>Option 2</td> <td>340</td> <td>240</td> </tr> <tr> <td>Small space</td> <td>Option 1</td> <td>300</td> <td>150</td> </tr> </tbody> </table> <p>2. The space must permit the mounting of a plate in a position as close to vertical as possible taking into account the shape of the bodywork.</p> <p>3. An external body surface or a purpose-designed mounting system securely attached to the vehicle must be provided, to hold the plate in a fixed position (see Note 2).</p> <p>4. The whole of the yellow shaded portion of the IVA Test plate must be capable of being easily seen from every point along the test line.</p>			Minimum Width (mm)	Minimum Height (mm)	Euro space	Option 1	520	120		Option 2	340	240	Small space	Option 1	300	150
		Minimum Width (mm)	Minimum Height (mm)														
Euro space	Option 1	520	120														
	Option 2	340	240														
Small space	Option 1	300	150														

Rear Registration Plate Space 04

Record of Revision

Revision	Date	Description of Change
1	18/04/2011	Version 1

05 Steering Effort

Application: All Vehicles

Method of Inspection	Required Standard
<p>This inspection is to ensure that any Manual or Power Assisted steering system fitted to the vehicle will ensure easy and safe handling of the vehicle up to the maximum design speed of the vehicle.</p> <p>In the case of unmodified Mass Produced vehicles, the standards in this section shall be considered to be met.</p> <p>Where evidence suggests that the vehicle has been modified, the examiner shall assess whether the modification would be likely to materially affect the performance of the relevant component or system, and if so, carry out assessment against the RS</p> <p>With the vehicle's steered wheels safely held on turning plates operate the vehicles steering from lock to lock, with and without the power assistance (if fitted). Assess the operation of the system.</p> <p>Conversions that are not based on N1 vehicles may comply with the applicable requirements of the original base vehicle. Documentary evidence of base or incomplete vehicle approvals will be deemed acceptable provided the maximum mass of the original approvals has not been exceeded.</p> <p>Vehicles fitted with complex drive by wire or hydraulic steering systems cannot be assessed by inspection, therefore documentary evidence must be provided.</p>	<ol style="list-style-type: none"> 1. The safe control of the vehicle must not be impaired due to a design or construction feature of characteristic of the steering system. 2. The steering must act primarily on the front wheels. 3. The steering system must operate smoothly from lock to lock and without undue stiffness with and without power assistance (if fitted). 4. The steering angle must not be limited by any part of the steering, transmission, or suspension system unless the components have been specifically designed for this purpose. 5. If the vehicle is fitted with power assisted steering, the steering must still operate with the assistance disabled. 6. The steered wheels and tyres must not foul, or be likely to foul, other parts of the vehicle under normal operating conditions. 7. Steering components must not foul, or be likely to foul, other parts of the vehicle under normal operating conditions. 8. When the vehicle is driven at speeds above 10mph, there must be a degree of steering "self-centering" evident.

Record of Revision

Revision	Date	Description of Change
1	18/04/2011	Version 1

06 Door Latches and Hinges

Application: All Vehicles

Method of Inspection	Required Standard
<p>This inspection applies to doors and to other aperture covers fitted to the vehicle. Compliance may be demonstrated by submission of documentary evidence or an inspection of the vehicle.</p> <p>In the case of unmodified Mass Produced vehicles, the standards in this section shall be considered to be met.</p> <p>Where evidence suggests that the vehicle has been modified, the examiner shall assess whether the modification would be likely to materially affect the performance of the relevant component or system, and if so, carry out assessment against the RS</p> <p>A side-screen which may be mounted in a structure, and which in either case is hinged to allow entry/ exit, and which is permanently secured to the vehicle (i.e., not detachable) is considered to be a door and is subject to the requirements of this section.</p> <p>Doors designed to be easily attached to or removed from a motor vehicle manufactured for operation without doors need only comply with required standard 3.</p> <p>Note 1: Doors which do not give direct access to seats that are designed for normal use while the vehicle is travelling on the road, i.e., where the longitudinal plane of the most inboard point of the door is more than 300mm from the longitudinal plane of the nearest edge of the seat are exempt from this requirement.</p>	<ol style="list-style-type: none"> 1. All driver and passenger doors fitted to the sides of the vehicle must have a latch mechanism with both intermediate and fully latched positions. Alternatively, doors must be fitted with a safety bolt and an audible warning device, which activates when the vehicle is being driven if the bolt is not in the “secured” position (see Note 2). 2. All driver and passenger hinged doors must have a latch mechanism that will withstand a load which is likely to be applied in normal driving conditions, in both intermediate and fully latched positions, unless fitted with a safety bolt and audible warning device where it will only need to meet this requirement in the secured (locked) position (see Notes 1 & 2). 3. Hinge-mounted side doors (excluding gullwing and bus type folding doors) must hinge from the front of the door in relation to the direction of forward travel (see Note 3). 4. Gullwing or suicide doors fitted to the sides of the vehicle must be <ol style="list-style-type: none"> a. fitted with a device that automatically moves the door to the closed or intermediate latched position if unlatched when the vehicle is moving forward, or b. fitted with a safety bolt and an audible warning device, that activates when the vehicle is being driven if the bolt is not in the “secured” position.

Door Latches and Hinges 06

Method of Inspection	Required Standard
<p>Note 2: Any power operated door where force applied by the power actuator is sufficient to keep the door completely closed even when any load is applied is exempt from this requirement.</p> <p>Note 3: Overlapping double doors are deemed to comply with required standard 3 provided that the front door overlaps the rear door when closed. Suicide doors will not comply with required standard 3 but are permitted if they comply with required standard 4.</p> <p>Note 4: There is no requirement for an interior operating control on any access door behind the driver or front passenger seats.</p> <p>Door Means a hinged or sliding door which leads directly into a compartment that contains one or more seating positions.</p> <p>Gullwing door A door that hinges from top of the door aperture.</p> <p>Suicide Door A door that hinges from the rear of the door aperture.</p>	<ol style="list-style-type: none"> 5. All doors intended for passenger use must provide an adequate opening to enable safe access to and from the vehicle. 6. Where a vehicle is fitted with doors all the edges of the apertures (with the door open) that are contactable with a 100mm diameter sphere must be at least blunted. 7. All front passenger doors must be fitted with internal operating controls which are accessible from the adjacent seating position (see Note 4). 8. All aperture covers must secure in the fully closed position.

Door Latches and Hinges 06

Record of Revision

Revision	Date	Description of Change
1	18/04/2011	Version 1
2	05/10/2015	Insert new note 6 and revise RS 5 & 7.
3	03/04/2018	Remove numbering from Notes 1 & 2, renumber remaining Notes & insert definition of doors (parity with M1 manual).

This page intentionally left blank

07 Audible Warning

Application: All Vehicles

Method of Inspection	Required Standard
<p>Ensure that the vehicle is fitted with a horn which when operated emits a continuous uniform sound that is capable of giving audible warning of the approach or position of the vehicle to which it is fitted.</p> <p>In the case of unmodified Mass Produced vehicles, the standards in this section shall be considered to be met.</p> <p>Where evidence suggests that the vehicle has been modified, the examiner shall assess whether the modification would be likely to materially affect the performance of the relevant component or system, and if so, carry out assessment against the RS</p> <p>In the case of Armoured vehicles exemption from RS 3 and 4 of this section is permitted if it can be demonstrated to the satisfaction of the Approval Authority that it is impossible for the vehicle to comply due to its special purpose.</p> <p>Note 1: For the purposes of this item "horn" means an audible warning device not being a bell, gong, or siren.</p>	<ol style="list-style-type: none"> 1. The vehicle must be fitted with a horn (see Note1). 2. The horn must be secure 3. The horn must emit a continuous uniform sound. 4. The horn must perform to an equivalent level of an EC Type Approved vehicle.

Record of Revision

Revision	Date	Description of Change
1	18/04/2011	Version 1
2	31/07/2011	Restricted exemption for Armoured vehicles to RS 3 & 4 only
3	01/07/2018	Link RS1 to Note 1

08 Indirect Vision

Application: All Vehicles

Method of Inspection	Required Standard
<p>This inspection is to ensure that obligatory mirrors/camera-monitor systems (CMS) meet the appropriate safety standards and offer an acceptable standard of rearward vision</p> <p>CMS will only be required to meet RS4, RS6, RS12 and RS13.</p> <p>In the case of Armoured vehicles exemption from any requirement of this section is permitted if it can be demonstrated to the satisfaction of the Approval Authority that it is impossible for the vehicle to comply due to its special purpose.</p> <p>Note 1: All obligatory mirrors fitted to the vehicle are as follows</p> <ol style="list-style-type: none"> 1. One interior mirror of Class I 2. One exterior mirror on the offside of Class II or Class III. <p>Note 2: These dimensions are the minimum requirements of the reflective surface and not the overall size of the mirror assembly.</p> <p>Note 3: The interior mirror must be positioned as far as is practical to afford the best possible view to the rear, if the interior rear-view mirror does not provide any rearward vision its presence shall not be required.</p> <p>Note 4: All mirrors must be attached by a method normally used by a major manufacturer; mirrors attached by suction are not permitted.</p>	<ol style="list-style-type: none"> 1. The vehicle must have an offside exterior mirror fitted. 2. An interior mirror must be fitted (see Note 3). 3. The vehicle must have a nearside exterior mirror fitted (if the interior rear view mirror gives no view to the rear or the rear window is less than 70% light transmittance) (see Notes 3 & 5). 4. All obligatory mirrors/CMS must be securely mounted to the vehicle, to ensure that the field of view does not change (see Note 4). 5. All mirrors must be adjustable. 6. Obligatory mirrors/CMS must be mounted so as to prevent the driver misinterpreting the image because of vibration. 7. All mirrors must have an acceptable approval marking or have equivalent characteristics to a mirror approved for use on a vehicle of the same category as follows: <ul style="list-style-type: none"> • The reflective surface must be encased in a protective housing • surfaces contactable by a 165mm sphere (interior) or a 100mm sphere (exterior) must have a radius of curvature of at least 2.5mm – except for fixing holes or recesses less than 12mm wide, which must be blunted 8. An interior mirror must be a minimum of 40mm high by 80mm long (see Note 2 and Figure 1).

Indirect Vision 08

Method of Inspection	Required Standard
<p>Note 5: If the vehicle has a rear view window fitted which is less than 70% light transmittance (marked with a V) a nearside exterior mirror is required.</p> <p>Note 6: If fitted, an optional nearside mirror may supplement the field of view requirements of the obligatory mirrors</p> <p>Note 7: Where a valid approval or test report is available which covers the vehicle in its finished state, a field of view check is not required.</p> <p>Note 8: There is no requirement for seatbelts to be worn when assessing the adjustability of any mirror.</p>	<p>9. An exterior mirror must be a minimum of 40mm high and 70mm long and be able to incorporate a measurement parallel to the height of the rectangle at least 70mm in length within the lens (see Note 2 and Figure 1).</p> <p>10. The interior mirror must be adjustable from the normal driving position (see Note 8).</p> <p>11. The mirror fitted to the driver's side of a vehicle must be adjustable from the driving seat while the door is closed, although the window may be open (see Note 8). The mirror may, however, be locked in position from the outside. Alternatively, if knocked out of alignment, it must be capable of being returned to its former position without the need for adjustment.</p> <p>12. An obligatory mirror or CMS must provide the required field of view (see Annex 1 and Notes 6 & 7).</p> <p>13. CMS must be approved to the requirements of UNECE Regulation 46.04 paragraph 6.2.2; documentary evidence will be required.</p>

Figure 1

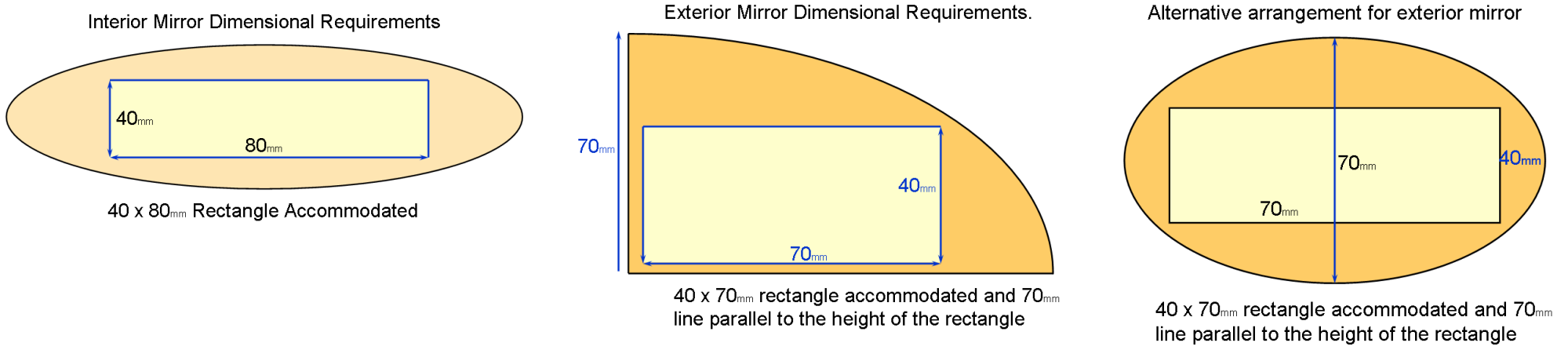

Annex 1: Mirror Field of View Check

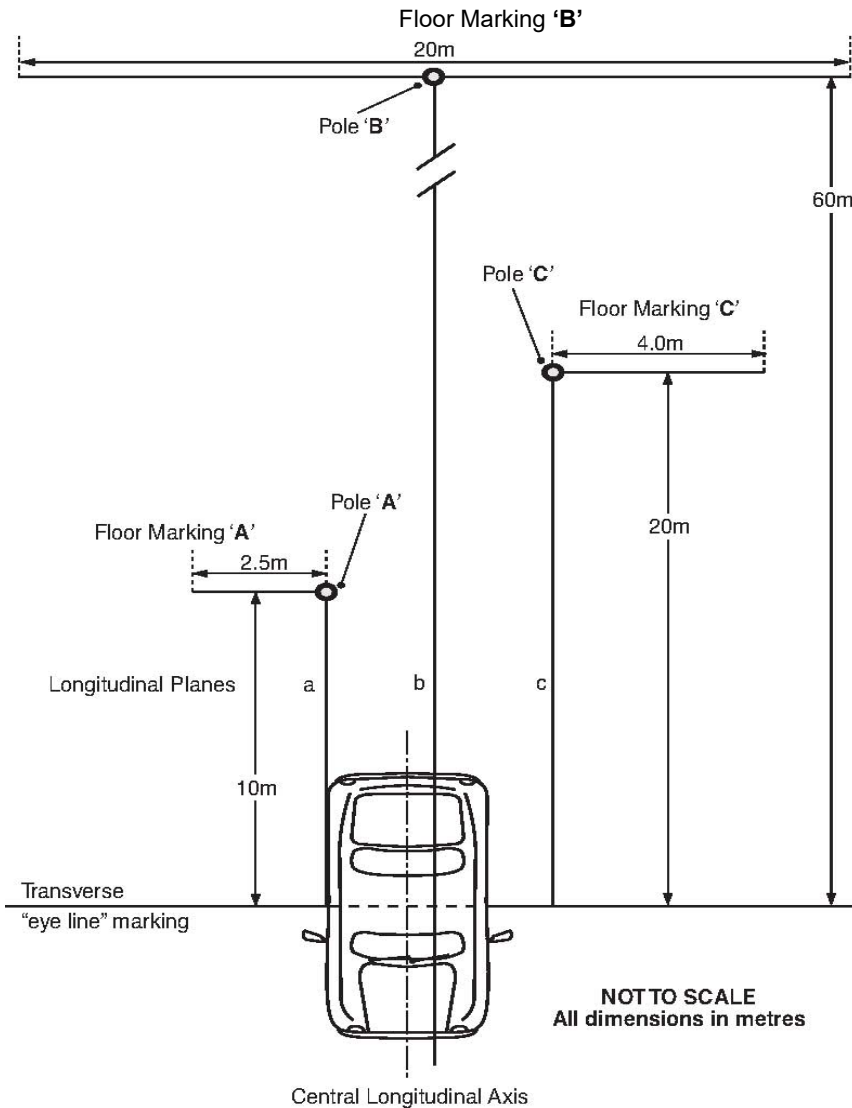

With a pole positioned vertically at the junction of lines 'a' and 'A' in respect of the offside exterior mirror; 'b' and 'B' in respect of the interior mirror; and where required, (see note 2) 'c' and 'C' in respect of the nearside exterior mirror, mark each pole (A, B and C) to show the height of the upper edge of the corresponding mirror reflective surface (the "mirror dimension").

In cases where the driver's seat is adjustable, position the seat in the rearmost position.

When seated in the driver's seat looking ahead and in a comfortable upright driving position, align the vehicle such that your eye position is vertically aligned with the transverse floor "eye-line" marking and;

1. the offside extreme outer edge of the vehicle is positioned along line 'a'; check that up to the height of the "mirror dimension" on pole 'A' and the whole of the floor marking 'A' is visible in the offside exterior mirror (see note 1);
2. the longitudinal centre line of the vehicle is positioned along line 'b'; check that up to the height of the "mirror dimension" on pole 'B' and the whole of the floor marking 'B' is visible in the interior mirror (see note 1);
3. (where required) the nearside extreme outer edge of the vehicle is positioned along line 'c'; check that up to the height of the "mirror dimension" on pole 'C' and the whole of the floor marking 'C' is visible in the nearside exterior mirror (see note 1).

NOTE 1: While sitting in the driving position, facing forward, the respective field of view in each mirror should be obtainable by pivoting the eyes/head, without bodily movement.

NOTE 2: Obstruction by 'sundry' items in the case of an interior mirror of 15% and in the case of an exterior mirror 10% is permitted

NOTE 3: If an interior mirror does not provide the required field of view, a nearside exterior mirror meeting the appropriate field of view requirement must be fitted.

Annex 2

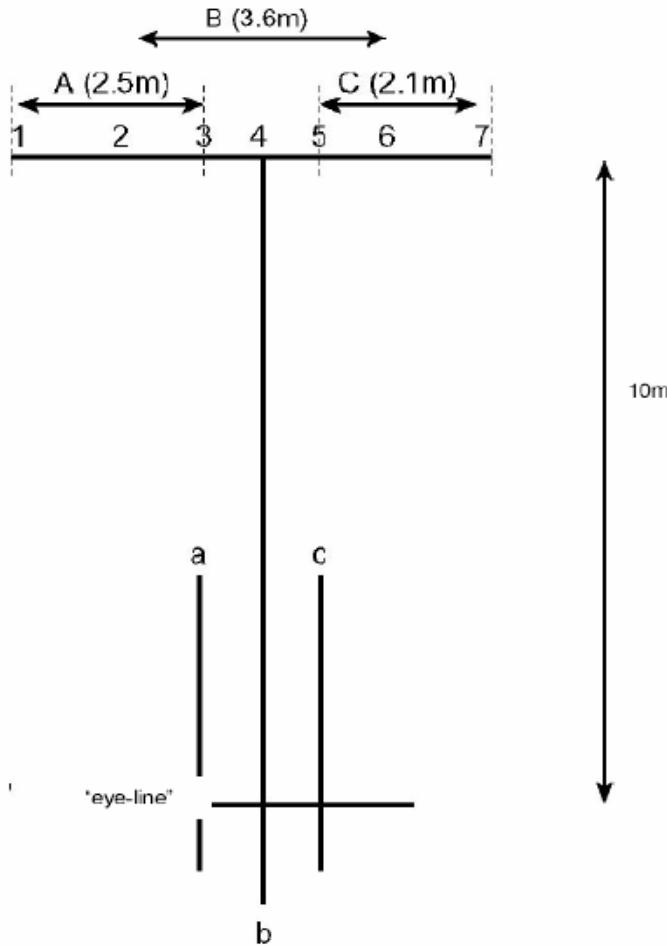

Position poles and “flags”

With a pole positioned vertically at the floor marking 3 in respect of the offside exterior mirror; 4 in respect of the interior mirror; and where required, (see note 3)

5 in respect of the nearside exterior mirror, mark poles 3, 4, and 5 to show the height of the upper edge of the corresponding mirror reflective surface (the “mirror dimension”).

Using the chart shown above, by reference to the “mirror dimension” (column X) obtain the interior mirror lower marker height (column Y) and mark a horizontal line on poles 2, 4 and 6 at the given height. Where required, (see note 3) obtain the nearside mirror lower marker height (column Z) and mark horizontal line on poles 5 and 7 at the given height.

In cases where the driver’s seat is adjustable, position the seat in the rearmost position.

When seated in the driver’s seat looking ahead and in a comfortable upright driving position, align the vehicle such that your eye position is vertically aligned with the transverse floor “eye-line” marking and with the offside extreme outer edge of the vehicle positioned along line ‘a’; check that up to the height of the “mirror dimension” on pole 3 and the whole of the floor marking 1 to 3 is visible in the offside exterior mirror (see note 1 & 2).

The longitudinal centre line of the vehicle positioned along line ‘b’; check that the section of pole 4 between the upper (“mirror dimension”) marker and the lower marker, and the whole of the horizontal line formed between poles 2, 4 and 6 is visible in the interior mirror (see notes 1, 2 & 3).

The nearside extreme outer edge of the vehicle (where required) positioned along line ‘c’; check that the section of pole 5 between the upper (“mirror dimension”) marker and the lower marker, and the whole of the horizontal line formed between poles 5 and 7 is visible in the nearside exterior mirror (see notes 1, 2 & 3);

NOTE 1: While sitting in the driving position, facing forward, the respective field of view in each mirror should be obtainable by pivoting the eyes/head, without bodily movement.

NOTE 2: Obstruction by ‘sundry’ items in the case of an interior mirror of 15% and in the case of an exterior mirror 10% is permitted

NOTE 3: If an interior mirror does not provide the required field of view, a nearside exterior mirror meeting the appropriate field of view requirement must be fitted.

(Y) Interior Mirror Marker Lower Height (mm)	(X) Height To Top Of Lens (mm)	(Z) Nearside Mirror Marker Lower Height (mm)
1230	1500	713
1222	1490	708
1214	1480	703
1205	1470	698
1197	1460	694
1189	1450	689
1181	1440	684
1173	1430	679
1164	1420	675
1156	1410	670
1148	1400	665
1140	1390	660
1132	1380	656
1123	1370	651
1115	1360	646
1107	1350	641
1099	1340	637
1091	1330	632
1082	1320	627
1074	1310	622
1066	1300	618
1058	1290	613
1050	1280	608
1041	1270	603
1033	1260	599
1025	1250	594
1017	1240	589
1009	1230	584
1000	1220	580
992	1210	575
984	1200	570
976	1190	565
968	1180	561
951	1160	551

(Y) Interior Mirror Marker Lower Height (mm)	(X) Height To Top Of Lens (mm)	(Z) Nearside Mirror Marker Lower Height (mm)
943	1150	546
935	1140	542
927	1130	537
918	1120	532
910	1110	527
902	1100	523
894	1090	518
886	1080	513
877	1070	508
869	1060	504
861	1050	499
853	1040	494
845	1030	489
836	1020	485
828	1010	480
820	1000	475
812	990	470
804	980	466
795	970	461
787	960	456
779	950	451
771	940	447
763	930	442
754	920	437
746	910	432
738	900	428
730	890	423
722	880	418
713	870	413
705	860	409
697	850	404
689	840	399
681	830	394
672	820	390

(Y) Interior Mirror Marker Lower Height (mm)	(X) Height To Top Of Lens (mm)	(Z) Nearside Mirror Marker Lower Height (mm)
664	810	385
656	800	380
648	790	375
640	780	371
631	770	366
623	760	361
615	750	356
607	740	352
599	730	347
590	720	342
582	710	337
574	700	333
566	690	328
558	680	323
549	670	318
541	660	314
533	650	309
525	640	304
517	630	299
508	620	295
500	610	290
492	600	285
484	590	280
476	580	276
467	570	271
459	560	266
451	550	261
443	540	257
435	530	252
426	520	247
418	510	242
410	500	238

NOTE: Where the “mirror dimension” is outside the scope of this table the lower marker height for the

- Interior Mirror = “mirror dimension” (height to top of lens) x 82%
- Nearside Mirror = “mirror dimension” (height to top of lens) x 47.5%

Mirror field of View – Alternative Test Procedure

Pole and Marker Positions

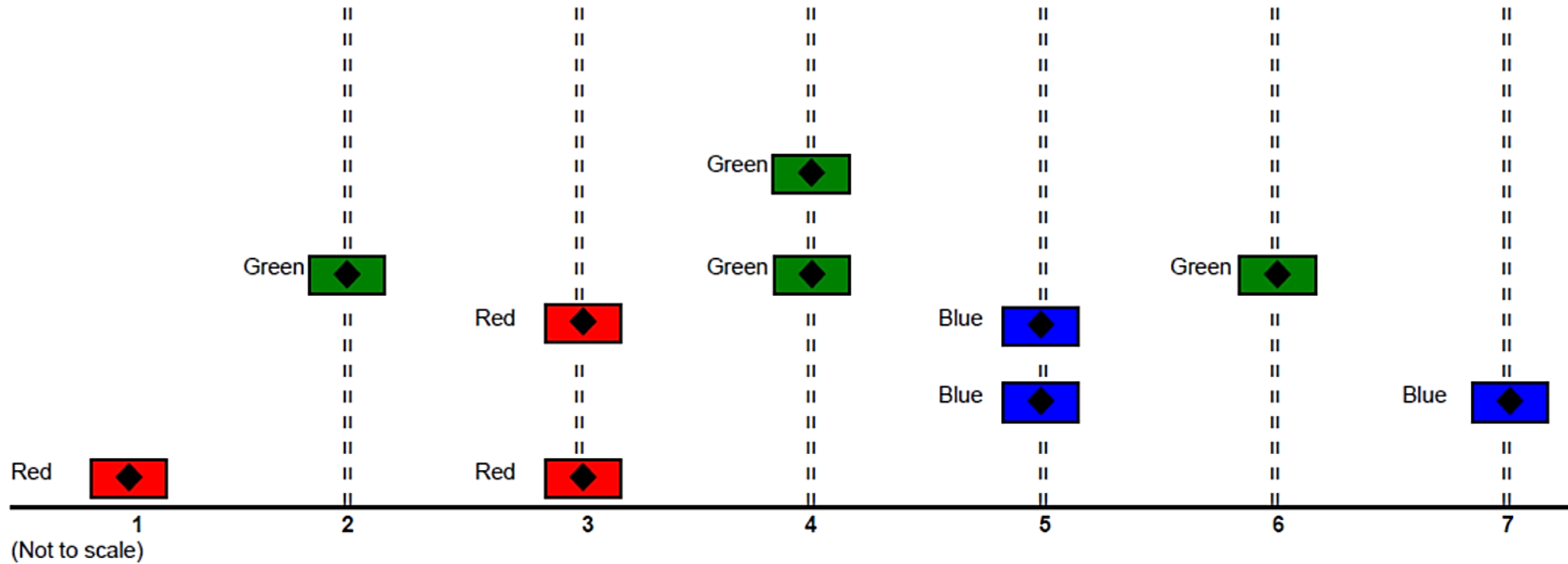

Offside Mirror (red markers) - Pole 3 in line with mirror test area line "a", and marker 1 outer edge placed 2.5 metres from pole 3.

Interior Mirror (green markers) - Pole 4 placed on mirror test area centre line "b", and Poles 2 and 6 placed 1.8 metres either side of pole 4.

Nearside Mirror (blue markers) (where required) - Pole 5 in line with mirror test area line "c" and pole 7 placed 2.1 metres from pole 5.

Record of Revision

Revision	Date	Description of Change
1	18/04/2011	Version 1
2	31/10/2011	Insert new Note 7 and link from RS12
3	03/04/18	Correct RS11, add new Note 8 linked from RS10 & RS11.
4	01/07/2018	Camera-monitor system requirements added.
5	01/09/2020	Correct pole numbering on Alternative Test Procedure diagram.

09A Brake Systems

Application: Vehicles subject to Basic requirements

Method of Inspection	Required Standard
<p>Ensure that all vehicles are fitted with braking systems capable of stopping the vehicle in a safe controlled manner and prevent the vehicle from moving without the control of the driver. The systems must be correctly constructed allowing for ageing, corrosion, and the stresses to which the system that will be subjected</p> <p>Conversions that are not based on N1 vehicles may comply with the applicable requirements of the original base vehicle. Documentary evidence of base or incomplete vehicle approvals will be deemed acceptable provided the maximum mass of the original approvals has not been exceeded.</p> <p>Note 1: The secondary system can be either one half of the split system (following failure of the other half) or secondary can be on the handbrake (Secondary/Park).</p>	<p>Service</p> <ol style="list-style-type: none"> 1. The vehicle must be fitted with a service braking system that is completely independent of the control of the parking brake, capable of functioning on all wheels by a single means of operation, which will gradually increase or reduce the braking force through action of the control. 2. The 'service' braking system must be capable of being operated from the driving seat, whilst keeping both hands on the steering wheel. This does not apply to the controls for use by a disabled driver, providing the adaptation allows the driver to control the steering at all times while operating either braking system. 3. The 'service' braking system must be capable of being operated to slow down the vehicle when it is moving in a forward or reverse direction. 4. The vehicle must be fitted with a split (dual) circuit brake system with each part of the system operating on at least two wheels (one on each side), capable of operating in the event of a failure of the service brake or its power assistance. <p>Secondary</p> <ol style="list-style-type: none"> 5. The vehicle must be fitted with a secondary system, capable of operating in the event of a failure of the service brake or its power assistance (see Note 1).

Brake Systems 09A

Method of Inspection	Required Standard
	<p data-bbox="1149 204 1261 231">Parking</p> <ol data-bbox="1198 268 2083 774" style="list-style-type: none"><li data-bbox="1198 268 2083 363">6. The 'parking' braking system must be capable of being operated from the driving seat, whilst keeping one hand on the steering wheel.<li data-bbox="1198 403 2083 467">7. The 'parking' braking system must be capable of being operated and released whether the vehicle is stationary or moving.<li data-bbox="1198 507 2083 603">8. The 'parking' braking system must be capable of being operated on all wheels of at least one axle enabling the vehicle to be held on an up or down gradient even in the absence of the driver.<li data-bbox="1198 643 2083 774">9. The 'parking' braking system must be capable of being operated using a control which is independent of the service brake, and once applied capable of being maintained in the 'on' position solely by mechanical means.

Record of Revision

Revision	Date	Description of Change
1	18/04/2011	Version 1

This page intentionally left blank

09B Service Brake Control / Mechanical Components

Application: Vehicles subject to Basic requirements

Method of Inspection	Required Standard
<p>All vehicles including a Disabled Person's vehicle where any adaptation or part of the system affected by an adaptation is subject to the requirements of this section. All service brake controls must operate in a forward direction i.e., in the direction of the force acting upon the driver as a result of the braking effort, when the vehicle is travelling in a forward direction; this is to ensure that under braking the brake is likely to remain applied. (Monotonic function)</p> <p>All components must be capable of withstanding the stresses, vibration, corrosion, and ageing (allowing for routine maintenance) to which they may be subject.</p> <p>Note 1: Fully apply the control twice, first slowly and then rapidly each time to a point where sustained pressure can be held or a maximum force of 700N (71 kgf) is applied, whichever occurs first (use the pressometer).</p> <p>Note 2: Utilizing only the tools or equipment normally supplied with the vehicle; for instance, by the provision of appropriate inspection holes or by some other means. The removal of front and/or rear wheels is permitted for this purpose, Alternatively, acoustical, or optical devices warning the driver at his driving position when lining replacement is necessary are acceptable.</p> <p>Note 3: If a vacuum servo is fitted, with the engine off, totally deplete the stored vacuum. Fully apply the service brake. Note whether the control can be felt to travel further when the engine is started. If operation is not detected, the vehicle should be re-checked with the brake partially applied</p>	<ol style="list-style-type: none"> 1. The brake control must be capable of being operated easily from the driving position without obstruction or abnormal hand/foot position and that the pedal (where fitted) has an anti-slip provision. 2. All service brake controls must operate in the same direction as the forces created when the vehicle is in forward direction. 3. A brake control, actuating linkage or associated component must be fully accessible for maintenance purposes. 4. A brake control, actuating linkage or associated component must be complete, so that it functions correctly. 5. A brake control, actuating linkage or associated component must be of adequate strength so as not to be likely to fail prematurely. 6. A brake control, actuating linkage or associated component must be made of a material sufficiently durable so as not to be likely to fail prematurely. 7. A brake control, actuating linkage or associated component must not be obstructed in its travel nor foul parts of the vehicle. 8. A brake control, actuating linkage or associated component mounting/bracket must be of adequate strength so as not to be likely to fail prematurely. 9. A brake control, actuating linkage or associated component mounting/bracket must be secure to the vehicle structure.

Service Brake Control / Mechanical Components 09B

Method of Inspection	Required Standard
<p>Note 4: Hydraulic valves that only operate automatically and react to vehicle loading or braking forces are permitted (Load Sensing and Gravity valves) Manually adjusted valves (other than to permit pre-setting the automatic function of a valve) are not permitted to be fitted even if they are rendered un-adjustable.</p> <p>Note 5: Bias bars and other mechanical adjusting devices fitted to twin master cylinders must be rendered inoperable by mechanical means e.g., lock wiring of components.</p> <p>Note 6: Adjusting front/rear brake bias may invalidate approval and breach Construction and Use requirements.</p>	<p>10. A brake control, actuating linkage or associated component mounting/bracket securing method must be of adequate strength so as not to be likely to fail prematurely.</p> <p>11. A brake control, actuating linkage or associated component pivot bearing/bush must be of adequate strength so as not to be likely to fail prematurely.</p> <p>12. A brake control, actuating linkage or associated component pivot bearing/bush must be secure such that it is unlikely to become displaced.</p> <p>13. Any brake control, actuating linkage or associated component pivot/linkage pins must be present and secure.</p> <p>14. Any brake control, actuating linkage or associated component locking/retaining devices must be present and secure.</p> <p>15. With the brake control fully applied there must be sufficient reserve travel (see Note 1).</p> <p>16. The brake control must not creep down while it is held under pressure (see Note 1).</p> <p>17. There must not be an indication of 'sponginess' when the brake control is operated, indicating air in the system (see Note 1).</p> <p>18. When the brake control is applied (following vacuum depletion) and the engine started a dip must be felt, indicating that vacuum assistance is working satisfactorily (see Note 3).</p> <p>19. On a full power hydraulic braking system, a warning device must be fitted, operative, and visible or audible to the driver, including in darkness.</p>

Service Brake Control / Mechanical Components 09B

Method of Inspection	Required Standard
	<p>20. All brake mechanical components must be secure, with relevant securing bolts, locking devices, retaining device etc. present and secure.</p> <p>21. A brake assembly on a FRONT axle of a vehicle must incorporate an automatic means of compensating for friction material wear.</p> <p>22. A brake assembly on a REAR axle of a vehicle must incorporate an automatic or manual means of compensating for friction material wear.</p> <p>23. The brake friction surfaces must have sufficient capacity to dissipate heat and prevent fade.</p> <p>24. It must be possible to easily check the wear on service brake linings, from the outside or underside of the vehicle (see Note 2).</p> <p>25. All braking controls must apply and release the relevant brakes at a rate comparable to that of an approved system.</p> <p>26. It must not be possible to manually adjust braking rates between axles (see Notes 4 & 5).</p> <p>27. Vehicles fitted with adjustable twin master cylinders that have been rendered inoperable by mechanical means to comply with RS 26 must have a label affixed on the master cylinder or the immediate vicinity with legible text as detailed in Note 6.</p> <p>28. The service braking system must act on braking surfaces permanently connected to the wheels through components of adequate strength.</p>

Service Brake Control / Mechanical Components 09B

Record of Revision

Revision	Date	Description of Change
1	18/04/2011	Version 1
2	03/04/2018	Update Note 1 with max force limit & add new RS 28.

Service Brake Control / Mechanical Components 09B

09C Park Brake Control / Mechanical Components

Application: Vehicles subject to Basic requirements

Method of Inspection	Required Standard
<p>The park brake lever needs to be checked throughout its operating range,</p> <p>Note 1: Parking brake reserve travel and locking positions are required to allow components such as brake cables to stretch without diminishing park brake performance.</p>	<ol style="list-style-type: none"> 1. A parking brake lever, actuating linkage, cable, or associated component must be complete so that it functions correctly. 2. A parking brake lever, actuating linkage, cable, or associated component must be of adequate strength so as not to be likely to fail prematurely. 3. A parking brake lever, actuating linkage, cable, or associated component must be made of a material sufficiently durable so as not to be likely to fail prematurely. 4. A parking brake lever, actuating linkage, cable, or associated component must not be obstructed in its travel nor foul parts of the vehicle. 5. A parking brake lever, actuating linkage, cable, or associated component mounting / bracket must be secure to the vehicle structure. 6. A parking brake lever, actuating linkage, cable, or associated component mounting / bracket securing method must be of adequate strength so as not to be likely to fail prematurely. 7. A parking brake lever, actuating linkage, cable, or associated component pivot bearing / bush must be of adequate strength so as not to be likely to fail prematurely.

Park Brake Control / Mechanical Components 09C

Method of Inspection	Required Standard
	<ol style="list-style-type: none"> <li data-bbox="1196 204 2047 300">8. A parking brake lever, actuating linkage, cable, or associated component pivot bearing / bush must be secure such that it is unlikely to become displaced <li data-bbox="1196 338 2047 402">9. A parking brake lever, actuating linkage, cable, or associated component pivot/linkage pins must be present and secure <li data-bbox="1196 440 2092 504">10. A parking brake lever, actuating linkage, cable, or associated component locking/retaining devices must be present and secure <li data-bbox="1196 542 2069 606">11. The parking brake ratchet pawl must engage positively with the ratchet teeth <li data-bbox="1196 644 2114 708">12. A hand lever operated parking brake must not disengage when the lever is knocked on each side and on the top. <li data-bbox="1196 746 2024 810">13. A lever operated parking brake when fully applied must have reserve travel and locking positions (see Note 1). <li data-bbox="1196 849 2092 976">14. With the ignition off, an electrically operated parking brake switch must be capable of applying the brake but must not be capable of releasing the brake. The switch must be protected from inadvertent use. <li data-bbox="1196 1015 2024 1078">15. The parking brake mechanism must incorporate a means of manual or automatic adjustment to compensate for wear.

Park Brake Control / Mechanical Components 09C

Record of Revision

Revision	Date	Description of Change
1	18/04/2011	Version 1
2	31/10/2011	Amend wording of RS 15 to correct compensation requirement
3	01/09/2020	Rewrite RS14 to clarify requirements.

This page intentionally left blank

09D Hydraulic and Vacuum Systems

Application: Vehicles subject to Basic requirements

Method of Inspection	Required Standard
<p>Where practicable, check all hydraulic and vacuum components for suitability of design, construction methods and materials, location, and mountings/fixings to the vehicle structure or other components.</p> <p>All components must be suitable to withstand the stresses, vibration, corrosion, and ageing (allowing for routine maintenance) to which they may be subject.</p> <p>Compression joints of the type using separate ferrules are not considered suitable for joints on hydraulic brake lines other than in the case of a hose designed for a high pressure application that incorporates an inner sleeve in the compression fitting.</p> <p>Note 1: Check for leaks in any part of the braking system, with or without the brake applied. For vehicles fitted with a vacuum servo or power braking system, the engine must be running during the inspection.</p> <p>Note 2: in the case of a conventional split system (with or without vacuum assistance) it will be assumed that a failure will result in the draining of the fluid. It may be necessary to confirm the fluid circuit through the master cylinder by documentary evidence.</p> <p>Note 3: One reservoir fluid warning lamp may fulfil the function of checking the fluid level (RS 18) and monitoring the hydraulic system (RS 19) providing both criteria are met.</p>	<ol style="list-style-type: none"> 1. A hydraulic and vacuum component must be complete, so that it functions correctly. 2. A hydraulic and vacuum component must be of adequate strength so as not to be likely to fail prematurely. 3. A hydraulic and vacuum component must be made of a material sufficiently durable so that it is unlikely to fail prematurely. 4. A hydraulic and vacuum component mounting/bracket must be secure to the vehicle structure or other components. 5. A hydraulic and vacuum component mounting/bracket must be of adequate strength so as not to be likely to fail prematurely. 6. A hydraulic and vacuum component mounting/bracket securing method must be of adequate strength and unlikely to fail prematurely. 7. A brake pipe or hose must not be fouled by moving parts. 8. A brake pipe or hose must not be kinked, stretched, or twisted. 9. A brake pipe or hose must be adequately clipped or otherwise supported. 10. A brake pipe or hose must have suitable joint fittings. 11. A brake pipe or hose must not be exposed to excessive heat.

Hydraulic and Vacuum Systems 09D





Method of Inspection			Required Standard
 <p>Figure 1</p>			<p>12. A hydraulic/vacuum component must not be subject to a corrosive environment and likely to fail prematurely.</p> <p>13. Components must not leak (see Note 1).</p> <p>14. A fluid reservoir filling port must be easily accessible.</p> <p>15. A fluid reservoir cap must be present and secure.</p> <p>16. It must be possible to check the fluid relative to the manufacturer's specified minimum level on all brake fluid reservoirs by the actual fluid level being visible through a transparent section of the reservoir, with the minimum level marked permanently on to this section. As an alternative, a red warning lamp (see Figure 1) must be capable of illuminating when the reservoir fluid falls to the minimum level.</p> <p>17. An indelible label must be affixed in a visible position within 100 mm of the filling ports of the fluid reservoirs to ensure that it is possible for the end user of the vehicle to identify the brake fluid used in braking system. DOT fluid references and/or the Symbols and text in table 1 are considered acceptable.</p> <p>18. Where a warning lamp is provided as the only means of checking the fluid level without opening the reservoir, it must be secure, operational, visible during daylight and darkness from the driving position, and fitted with a "test facility" that enables its operation to be checked from the driving position without opening the reservoir.</p>
Glycol based brake fluid	 	<p>DOT 3 DOT 4 DOT 5.1</p>	
Mineral based brake fluid	 		
Silicone based brake fluid		<p>DOT 5</p>	

Table 1

Hydraulic and Vacuum Systems 09D

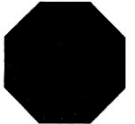
Method of Inspection	Required Standard
<p>Note 4: The vehicle must be driven and the operation (modulation) of the ABS system assessed under braking to indicate satisfactory operation of the system. NB This check is not necessary if the ABS warning lamp illuminates during a speedometer check indicating that the sensors are detecting unusual wheel speeds/operation.</p>	<p>19. The hydraulic system must be fitted with a red warning lamp, sensitive to line pressure and capable of signalling the failure of any part of the hydraulic system as soon as the brake is applied and remaining lit as long as the failure exists (with the ignition switched on). As an alternative, the warning lamp must be sensitive to the reservoir fluid level, providing the reservoir is directly connected to supply the pressure side of the master cylinder when the piston is in the “brakes off” position, so that a failure of either part of a split system would result in a continuous draining of the reservoir fluid when the control is released (see Notes 2 & 3).</p> <p>20. The hydraulic system failure warning lamp must be secure, operational, visible during daylight and darkness from the driving position, identifiable (i.e., labelled in a recognised form – see figure 1 for an example) and fitted with a “test facility” that enables its operation to be checked from the driving position without opening the reservoir.</p> <p>21. If the vehicle is fitted with an anti-lock braking system, all components must be present, undamaged, secure, connected, and operational so that the system is likely to function as intended (see Note 4).</p> <p>22. If the vehicle is fitted with an anti-lock braking system an operational warning lamp must be fitted to monitor the system, visible from the driving position, which operates when the anti-lock is energised, and extinguishes at the latest when the vehicle speed reaches 10km/h.</p>

Record of Revision

Revision	Date	Description of Change
1	18/04/2011	Version 1

09E Brake Performance

Application: Vehicles subject to Basic requirements

Method of Inspection	Required Standard
<p>All vehicles including a Disabled Person’s vehicle where any adaptation or part of the system affected by an adaptation is subject to the requirements of this sub-section and must meet the required standards.</p> <p>All brake efficiencies are calculated using the vehicle CLW or DGW (where available) whichever is the higher value as determined in section 48.</p> <p>All braking systems when operated must react at a speed comparable to systems fitted to an Approved vehicle. This is particularly relevant to delay of service brake operation with alternative systems such as remotely applied electric motors etc.</p> <p>When testing service brake performance on unladen vehicles premature wheel lock can occur, and less than the required brake effort is achieved. The required effort might not be achieved due to the action of the load sensing/pressure reducing equipment in the service brake system. In either of these cases, the service brake percentage efficiency is considered satisfactory if</p> <p>both front wheels lock and at least 100kg is achieved by each rear wheel, or for three axle vehicles, both front wheels lock and at least 50kg is achieved by each rear wheel.</p>	<p>Roller Brake Test</p> <ol style="list-style-type: none"> 1. A low braking effort must not be recorded from any wheel, indicating clearly that the brake is not functioning correctly. 2. The service brake performance must be at least 50%, (of the CLW or DGW as determined to be the highest) or more than half the road wheels lock. 3. The secondary brake performance must be at least 25%, (of the CLW or DGW as determined to be the highest) for: <ul style="list-style-type: none"> • each half of the split system or • the park brake if used as secondary. (see Note 7) or • more than half the road wheels lock 4. A significant braking effort must not be recorded from a road wheel without application of the brakes, indicating brake bind. 5. There must be no evidence of severe brake grab or judder as the brake is applied. 6. The braking efforts at the road wheels must increase progressively at about the same rate when the service brake is applied gradually.

Brake Performance 09E

Method of Inspection	Required Standard
<p>Roller brake tester –</p> <p>Certain vehicles must not be tested on a roller brake tester:</p> <ul style="list-style-type: none"> a. vehicles with more than one driving axle permanently engaged b. vehicles with belt driven transmission c. vehicles with brakes for which the servo only operates when the vehicle is moving. <p>These vehicles should be tested using a decelerometer.</p> <p>The engine must be idling when conducting the roller brake test for all vehicles fitted with a servo or full power hydraulic braking systems except for the brake distribution test (Standard 10), the depleted servo test (Standard 11) and the power hydraulic test (Standard 12).</p> <p>In some cases, it may be necessary to chock the wheels not under test. The rear wheels of light weight vehicles must be chocked when testing the front axle. This helps prevent the front of the vehicle ‘lifting’ in the rollers and may improve the efficiency reading obtained before wheel lock.</p> <p>The brake performance should be assessed with the braking surfaces at working temperature. It is acceptable to induce heat into the braking surfaces prior to conducting the test particularly where the vehicle has been transported to the test site.</p> <p>Position the front wheels in the rollers of the brake tester and then run both sets of rollers together to align the vehicle. With one set of rollers revolving at a time, gradually depress the service brake until maximum effort is achieved, or until the wheel locks.</p> <p>Record the reading at which the maximum braking effort is achieved for each wheel and whether lock-up occurs. Release the service brake.</p>	<ul style="list-style-type: none"> 7. The braking efforts at the road wheels must reduce at about the same rate when the service brake is released gradually. 8. The brake pedal must return to the fully off position. 9. The brake effort of one wheel must not be less than 70% of the effort recorded from the other wheel on any steering axle (an axle that provides the main source of directional control of the vehicle). 10. The braking ratio of the axles, for all values of total brake force must be less than the friction force ratio (taking into account weight transfer) between axles in running order (see Note 1). 11. The calculated service efficiency with the servo depleted must be at least 25% (see Note 2). 12. Where a vehicle is fitted with a full power hydraulic system, the calculated service brake efficiency after four full applications must be at least 25% (see Note 3). 13. A low braking effort must not be recorded from any wheel, indicating clearly that the parking brake is not functioning correctly. 14. The parking brake performance must be at least 18%, (of the CLW or DGW as determined to be the highest) unless more than half of the wheels lock as operated by the park brake.

Brake Performance 09E

Method of Inspection	Required Standard
<p>Start both sets of rollers and note whether a significant brake effort is recorded from any wheel without a brake being applied. Gradually depress the service brake and watch how the braking effort for each wheel increases. From the previous tests you will know the value at which wheel slip occurs. Aim to stop just short of this. Gradually release the service brake and observe how the braking effort at each wheel reduces checking that the pedal returns to the fully off position. Stop the rollers and record the out-of-balance braking effort between wheels on either side of the vehicle.</p> <p>Note 1: The requirements of Standard 10 shall not apply in the case of Mass-produced vehicles if the brakes on the rear are fitted with an anti-lock device which was fitted at the time of manufacture, and it appears that the anti-lock device complies with the definition of Directive 71/320/EEC, i.e., it comprises of sensors, control valves, and/or modulators to modulate the braking force of any wheel that is about to lock.</p> <p>Fit the brake pedal effort measuring device and deplete the vacuum from the servo reservoir (if fitted). In the case of the full power hydraulic system the pressure should not be depleted.</p> <p>Start both sets of rollers and, observing the load cell, progressively apply the service brake in increments. Aim to stop short of the value at which wheel-slip occurs. Record the brake effort obtained for each wheel for every increment of effort applied to the brake pedal. Stop the rollers.</p> <p>Where the vehicle is fitted with a servo – with one set of rollers revolving at a time and with the vacuum depleted, apply a load of:</p> <ul style="list-style-type: none"> • Foot control – 70kg (686N) • Other than foot control 60kg (588N) <p>Record the effort obtained from each wheel. If the control reaches the end of its travel before the full effort is applied the assessment is made from the reading obtained at that point. This test applies to all service brake</p>	<p>Decelerometer Test (see Note 4)</p> <ul style="list-style-type: none"> 15. The service brake performance must be a minimum of 50% 16. The parking brake performance must be a minimum of 18% 17. When the service brake is applied the brake must be capable of progressive operation. 18. When the service brake is applied there must not be severe grab or judder. 19. When the service brake is applied the vehicle should not deviate to the left or right 20. When the service brake is applied the pedal must return to the fully off position. 21. All wheels of the rear axle(s) must not lock prior to both wheels of the front axle. <p>Transmission Parking Brakes (see Note 5)</p> <ul style="list-style-type: none"> 22. The transmission parking brake efficiency must be at least 18% <p>Dynamic Brake Distribution Assessment (see Note 6)</p> <ul style="list-style-type: none"> 23. All wheels of the rear axle(s) must not lock prior to both wheels of the front axle.

Brake Performance 09E

Method of Inspection	Required Standard
<p>controls, e.g., any additional control fitted to a disabled person’s vehicle that operates the system.</p> <p>Note 2: Where a mass produced vehicle, built by a major manufacturer, has not had its braking system modified in any way this part of the examination can be by-passed.</p> <p>Note 3: Where the vehicle is fitted with a full power hydraulic braking system – In the case of an unmodified standard production vehicle RS 12 will be deemed to be met unless evidence suggests otherwise. For all other vehicle types, gradually deplete the stored energy until the pressure warning device operates. Carry out four full stroke applications of the service brake. Start both sets of rollers and gradually depress the service brake until maximum effort is achieved, or until wheel lock. Record the readings for all wheels at the point which maximum effort is achieved. Where a full power hydraulic braking system is designed to prevent depletion completely or until the pressure warning device operates (short of catastrophic damage) conduct those parts of the brake performance requirements that can be achieved.</p> <p>Parking brake – If the vehicle has a parking brake which operates on the axle being tested, with one set of rollers revolving at a time, gradually operate the parking brake until maximum effort is achieved, or until the wheel locks. Record the reading at which the maximum braking effort is achieved for each wheel and whether lock-up occurs. If the presenter insists that the parking brake cannot be applied unless the service brake is also applied documentary evidence of parking brake efficiency will be required.</p> <p>Drive the vehicle forward until the next axle is in the rollers. Repeat the above operations, record the figures obtained and calculate the braking performance values.</p>	

Brake Performance 09E

Method of Inspection	Required Standard
<p>Note 4: Decelerometer test – This method must only be used where the vehicle cannot be tested in the roller brake tester due to a design characteristic.</p> <p>Set up the decelerometer according to the manufacturer’s instructions. Drive the vehicle on a level road at a steady speed of approximately 20mph and note the brake efficiency recorded when progressively applying the service brake and the parking brake separately.</p> <p>During the service brake test observe (using an assistant if necessary) whether braking is progressive, if there is grab or judder, whether the vehicle deviates to the left or right during braking, and if the pedal returns to the fully off position.</p> <p>Drive the vehicle on a level road at a steady speed of approximately 20mph and apply the service brake sufficient only to obtain wheel lock. Observe whether all the wheels of the rear axle(s) lock prior to both wheels of the front axle.</p> <p>The presenter or another person may be required to drive the vehicle under the direction of the examiner.</p> <p>Note 5: Transmission parking brake – Place the wheels to be tested in the rollers and run both set together to align the vehicle. Chock the other wheels of the vehicle in front of and behind each wheel. Run both sets of rollers together and apply the brake slowly and progressively keeping the ratchet disengaged. Record and calculate readings.</p> <p>Note 6: Dynamic brake distribution assessment In certain instances, the roller brake testing results may give the examiner justification to carry out a dynamic assessment of brake force distribution.</p>	

Method of Inspection	Required Standard
<p>Drive the vehicle on a level road at a steady speed of approximately 20mph and apply the service brake sufficient only to obtain wheel lock. Observe whether all the wheels of the rear axle(s) lock prior to both wheels of the front axle.</p> <p>The presenter or another person may be required to drive the vehicle under the direction of the examiner.</p> <p>Note 7: The secondary system can be either one half of the split system (following failure of the other half) or secondary can be on the handbrake (Secondary/Park).</p>	

Record of Revision

Revision	Date	Description of Change
1	18/04/2011	Version 1
2	31/10/2011	Amend the minimum efficiency requirement in RS2
3	11/03/2013	Insert lock allowance in RS3
4	18/03/2013	RS15 Revise minimum brake performance figure
5	03/04/18	New Note 2, remaining Notes rationalised and renumbered, renumber links from RS.
6	01/07/2018	Note 3 and parking brake MOI expanded.

This page intentionally left blank

10 Electromagnetic Compatibility

Application: Spark Ignition Engine Vehicles

Method of Inspection	Required Standard
<p>The examiner will check that the vehicle complies with the required standard of interference suppression equipment.</p> <p>In the case of unmodified, Mass Produced vehicles the standards in this section shall be considered to be met.</p> <p>Where evidence suggests that the vehicle has been modified, the examiner shall assess whether the modification would be likely to materially affect the performance of the relevant component or system, and if so, carry out assessment against the RS.</p>	<ol style="list-style-type: none">1. The HT ignition system must be fitted with radio interference suppression equipment.2. The trade name or mark and trade description must be present on the interference suppression equipment.3. There must be a maximum of 120mm separation between trade markings on suppression cables.

Record of Revision

Revision	Date	Description of Change
1	18/04/2011	Version 1

13A Anti - Theft / Immobiliser

Application: Vehicles subject to Basic requirements

Method of Inspection	Required Standard
<p>Check, in addition to the normal “ignition” switch, that the vehicle is permanently fitted with an anti-theft device or an electronic immobiliser that can be activated to prevent the vehicle being driven or moved under its own power.</p> <p>A mechanical anti-theft device could be a steering lock or transmission lock. An electronic immobiliser can be activated by the ignition key (so would not be obvious) or could be separate, activated by a little fob type device.</p> <p>A manually operated battery master switch or a removable steering wheel would not be considered to be an anti-theft device.</p> <p>Conversions that are not based on N1 vehicles do not need to comply if there was no theft / immobiliser requirement for the base vehicle. Documentary evidence of base vehicle category or incomplete vehicle approvals will be deemed acceptable.</p> <p>Note 1. An electronic immobiliser must be designed so as to prevent the operation of the vehicle under its own power by disabling, in the case of aftermarket fitting, at least two separate vehicle circuits that are needed for vehicle operation under its own power (e.g., starter motor, ignition, fuel supply, pneumatically released spring brakes, etc.)</p>	<ol style="list-style-type: none"> 1. A vehicle MUST be fitted with either a mechanical anti – theft - device or an electronic immobiliser. 2. If fitted to the Vehicle, an anti – theft device <ol style="list-style-type: none"> a. must be operational b. must not operate on any part of the braking system. 3. If it incorporates a mechanical part that acts upon a system used to control the vehicle <ol style="list-style-type: none"> a. It must deactivate before the engine can be started b. It must be deactivated while the engine is running c. It must have an actuation which is a distinct and separate function from that of stopping the engine <p>Where the vehicle has no mechanical anti - theft device fitted:</p> <ol style="list-style-type: none"> 4. An electronic immobiliser must be fitted (see Note1).

Anti – Theft / Immobiliser 13A

Record of Revision

Revision	Date	Description of Change
1	18/04/2011	Version 1
2	05/10/2015	Correct Section number, add new Note 1 to MOI linked from RS 4

13B Anti – Theft / Alarm

Application: Vehicles subject to Basic requirements (optional fitment)

Method of Inspection	Required Standard
<p>Ensure the vehicle as presented is accompanied by satisfactory documentary evidence of compliance with the requirements for a “Category 1 immobiliser” installation</p> <p>An Armoured vehicle is exempt the requirements of this section.</p> <p>A “Category 1” installation refers to an immobiliser and an alarm.</p> <p>Check that any optional Panic Alarm which does not form part of the vehicle alarm system is accompanied by satisfactory documentary evidence of compliance.</p> <p>Panic Alarm means a device which enables a person to use an alarm, installed on the vehicle, to summon assistance in an emergency.</p> <p>Evidence of compliance for Alarm and Panic Alarm can be one of the following:</p> <ul style="list-style-type: none"> • Documentary evidence from a test laboratory. • Documentary evidence from the vehicle manufacturer (in the case of a mass produced vehicle). • An original certificate of installation from a Mobile Electronics and Security Federation (MESF) accredited installer. 	<ol style="list-style-type: none"> 1. The vehicle as presented must be accompanied by evidence of compliance where an alarm is fitted. 2. The vehicle as presented must be accompanied by evidence of compliance where a panic alarm is fitted.

Anti – Theft / Alarm 13B

Record of Revision

Revision	Date	Description of Change
1	18/04/2011	Version 1
2	31/10/2011	Remove acceptance of VISB installer and add acceptance of Thatcham Recognised installer
3	03/04/18	Remove wording 'Note 1'and 'Note' from MOI to align with M1 manual.
4	01/09/2020	Remove acceptance of Thatcham Recognised Installer.

14 Protective Steering

Application: Vehicles subject to Basic requirements

Method of Inspection	Required Standard
<p>This inspection is to assess the behaviour of the steering mechanism in the event of a frontal impact.</p> <p>This item does not apply in the case of vehicles:</p> <ul style="list-style-type: none"> a. complying with the Frontal Impact requirements b. with a maximum permissible mass exceeding 1500kg (usually M1 derived vehicles) <p>The requirements according to the category of the base or incomplete vehicle based on maximum mass may apply.</p> <p>Note 1: A vehicle that is unmodified forward of the 'B' pillar may retain the front airbag(s) if the original vehicle was approved with them installed. Where this is not applicable, as an alternative, front airbag(s) are permitted where compliance can be demonstrated to the relevant technical requirements of 96/79/EC (i.e.: a test report from a technical service).</p> <p>Examine the steering control for sharp points or edges.</p> <p>Check for parts of the steering control likely to catch in clothing.</p> <p>Examine the steering wheel and column assembly for evidence of energy absorbing properties. The steering control, the steering column, the steering shaft, the steering gear housing, and all other components designed to contribute to the absorption of energy in the event of impact against the steering control may be considered.</p>	<ol style="list-style-type: none"> 1. Any part of the steering control directed towards the driver which is contactable with a sphere of 165mm diameter must have a radius of curvature of at least 2.5mm. This does not apply if the vehicle is a mass-produced vehicle and has an airbag fitted to the steering control which was fitted at the time of manufacture. However, in this case all parts of the steering control must be blunted. 2. The steering control must be designed, constructed, and fitted in such a way that it is not possible to catch the driver's clothing or jewellery during normal driving movements. 3. The steering control and column assembly must provide adequate protection to the driver by absorbing energy from a driver-steering wheel impact. This is the case if the steering control has an approval (evidence may be markings or documents) or is similar to an approved steering control. The vehicle should be assessed using the material in Annex 1. 4. The vehicle and steering column assembly must be designed such that in the event of a frontal impact at 48km/h (30mph) the rearward horizontal displacement and vertical displacement of the top of the steering column and its shaft do not exceed 127mm. The vehicle should be assessed using the material in Annex 1. 5. Airbags are not permitted on vehicles which are: <ol style="list-style-type: none"> i. an amateur built vehicle ii. a vehicle manufactured in very low volume (see Note 1) iii. a vehicle manufactured using parts of a registered vehicle (see Note 1)

Protective Steering 14

Method of Inspection	Required Standard
In order to assess the system for RS 3 and RS 4, the inspector will need access to all steering components, mountings, and vehicle structure forward of any steering components. This may involve the removal of body and trim panels.	iv. a rebuilt vehicle

Annex 1

The vehicle structure ahead of the steering rack or box

Of primary concern is the position of the steering rack or box. If the rack or box is ahead of the axle centreline, there will clearly be less of the vehicle structure available to deform and absorb energy than if the rack is behind the axle. Check for some energy absorbing device such as

1. an energy absorbing bumper, or bumper mounting (e.g., mounted on hydraulic dampers or telescopic tubes).
2. a crushable section of chassis comprising one or more deliberate weaknesses;
3. in the case of a tubular chassis, a deliberately un-triangulated bay or arrangement of tubes likely to deform progressively;
4. in the case of a composite monocoque an area of bodywork which the presenter can demonstrate has been designed to crush progressively and dissipate energy;
5. in the case of any vehicle, a non-structural nose cone of any material which the presenter can demonstrate has been designed to absorb energy.

Note 1: The first area of the vehicle to make contact with a barrier in a crash test may not be the chassis. The front wheels may do this. If this is the case, the load path from the hub carrier to its mountings on the chassis should be examined. The initial deformation might take place to the sides rather than the front of the chassis.

Note 2: If the steering rack or box is mounted behind the axle centreline, then there is far more room for the chassis to deform before moving the steering column backwards. **A well-designed vehicle will minimise further deformation once the impact has reached the steering rack or box.**

Note 3: In cases where the steering rack or box is mounted behind the axle centreline, it may well be behind part of the engine or gearbox. In this case, check that no rigid part of the power plant is likely to bear directly against the end of the steering shaft as it enters the rack or box and in so doing, transmit a force up the column towards the driver.

An offset between the steering column and the input shaft of the steering rack or box

In cases where an intermediate shaft is used, it will be connected to the steering column at one end and the steering rack or box at the other, by means of universal joints and/or flexible couplings. The greater the angle through which the joints run, the more effective they will be in preventing movement being transmitted up the steering column. While it is unlikely that joints of this type will work at angles above 30 degrees, they are unlikely to be effective

Protective Steering 14

if the angle between the steering column and the intermediate shaft (when viewed from the side or the top of the vehicle) is less than 10 degrees.

A telescopic intermediate shaft

This is a common arrangement and may take the form, for example, of a sliding splined shaft, a sliding clamp arrangement on a non-circular shaft (e.g., triangular), or a device that permits disengagement of the upper column from the lower column.

A collapsible element in the upper column

This may take many forms. Expanded metal tubes or convoluted tubes (in association with sheer pins in the column shaft) or sliding splines are three of the most common. These are designed primarily to allow the steering wheel and column to move away from the driver while absorbing some of his or her deceleration if the driver were to hit the steering wheel.

Note: Driver impact against the wheel is still possible even when wearing a seat belt, particularly a fixed type rather than an inertia reel type.

A steering wheel incorporating an airbag

In cases where the vehicle was designed and fitted with an air bag as manufacturer's original equipment, there should be no reason to doubt its effectiveness providing the vehicle has not subsequently been modified.

Steering wheel construction

It is vital that the wheel is constructed so as to minimise the risk of facial injuries or concussion. The rim of the wheel should be padded or at least made from a material which when deformed does not splinter or fragment. The centre boss should be padded or recessed below the level of the rim. Wheels with a very deep dish are stiffer than flatter wheels and, as such, will absorb less energy.

The centre boss will often be of a collapsible type comprising a convoluted crushable section or a series of metal fingers with a deliberate fold introduced to initiate a collapse.

Bolts used to secure the wheel to its boss (if exposed) should ideally be flush with the wheel surface but otherwise are required to meet the radius requirements if contactable.

Bare metal spokes are allowed as long as they conform to the edge radius requirements. Components likely to catch in the driver's clothing or jewellery are not permitted.

Note: It is possible to fit an 'aftermarket' steering wheel which has been approved for use on any design of column. These will be referred to as "Separate Technical Units". If the presenter can provide satisfactory documentary evidence that this is the case, a "Separate Technical Unit" may be acceptable.

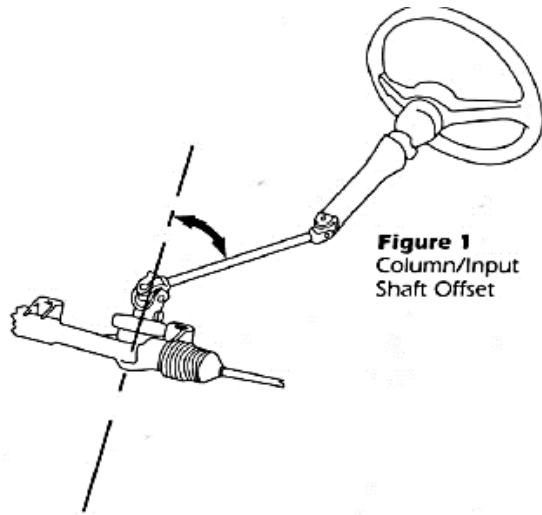

Figure 1
Column/Input
Shaft Offset

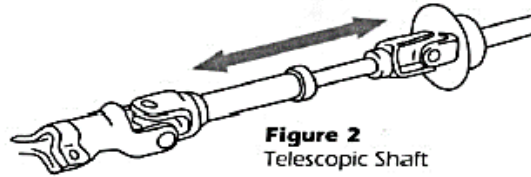

Figure 2
Telescopic Shaft



Figure 3
Sliding Clamp

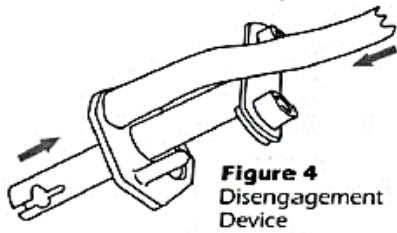

Figure 4
Disengagement
Device

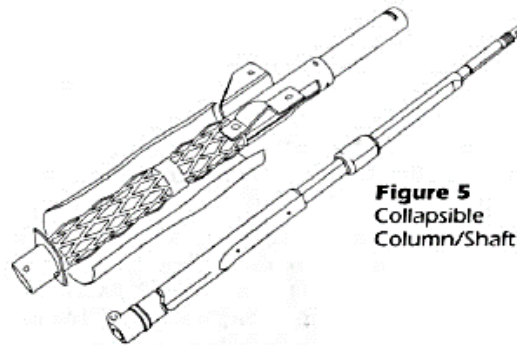

Figure 5
Collapsible
Column/Shaft

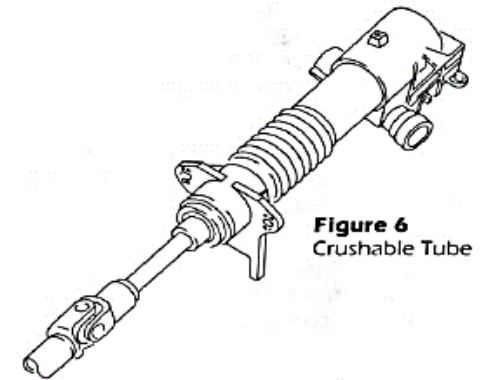

Figure 6
Crushable Tube

Record of Revision

Revision	Date	Description of Change
1	18/04/2011	Version 1
2	01/04/2022	RS 5 amended to correctly reflect RV(A)R 2020; new Note 1 added.
3	09/10/2024	Revise Note 1 & add reference to Note 1 from RS5, item iii) (TSE IVA N1 014 004).

This page intentionally left blank

15 Seat Strength

Application: All Vehicles

Method of Inspection	Required Standard
<p>The required standards do not apply to seats intended for use solely while the vehicle is stationary or for when the vehicle is not used on a public road. (which only have to be secure enough to retain the seat in its intended position) and</p> <p>Any seats which are not for use when travelling on a public road must be clearly identified to users by means of a pictogram or a sign with appropriate text.</p> <p>Base or incomplete vehicle approvals will be deemed acceptable provided the maximum mass of the original approvals has not been exceeded.</p> <p>Note 1: If attached to a non-metallic floor pan separate from the chassis, adequate support to spread the load of the anchorage is required, e.g., spreader plates/stiffening ribs etc.</p> <p>Note 2: In respect of a seat that comprises of a “lift-out” backrest and/or squab it will be considered secure providing, when in the operational position, it is located such that there is no possibility of accidental lateral or longitudinal movement within the vehicle whether it is in use or not.</p> <p>Note 3: On a seat to which a seat belt is mounted (integral seat belt) consideration must be given to the seat mounting as part of the seat belt anchorage.</p>	<ol style="list-style-type: none"> 1. Every seat must be securely attached to the vehicle structure, or other obvious suitable load bearing parts of the vehicle (see Notes 1, 2, & 3). 2. Every seat mounting must be of adequate strength to support the loads likely to be imposed (see Notes 1, 2, & 3). 3. Each seat, seat back adjustment and seat displacement system must incorporate an automatic locking system which operates in all positions provided for normal use. 4. A seat fitted with a displacement device to facilitate access by passengers must be fitted with an unlocking control which is accessible from outside the vehicle when the door is open. Where the seat immediately behind the seat concerned is designated for an adult, the unlocking control must also be easily accessible from this position. 5. The rear parts of the seats must not have rough or sharp edges likely to increase the risk of injury to the occupants (see Note 5).

Method of Inspection	Required Standard
<p>Note 4: A seat/seat back INERTIA locking device is acceptable, i.e., a device that operates during the deceleration the vehicle.</p> <p>Note 5: The surface of the rear parts of seats shall exhibit no dangerous roughness or sharp edges likely to increase the risk of severity of injury to the occupants. This will only be assessed where seats are positioned behind.</p>	

Record of Revision

Revision	Date	Description of Change
1	18/04/2011	Version 1

This page intentionally left blank

17 Speedometer and Reverse Gear

Application: All Vehicles having a maximum speed exceeding 25mph

Method of Inspection	Required Standard																		
<p>A vehicle must indicate an accurate speed to the driver at all times and must be capable of traveling in a rearward direction under its own power.</p> <p>Where the accuracy of the device is in question, (i.e.: any vehicle other than an original unmodified speedometer fitted to an mass produced vehicle which its self has no modifications that would affect the accuracy of the device) and with the vehicle positioned on, or fitted with a speed measurement device, operated to the manufacturer’s instructions, drive the vehicle at a stable speedometer indicated speed of 35mph and note the true speed. Repeat at four more speeds up to and including 70mph as is necessary to confirm compliance.</p> <p>Where the speed of the vehicle cannot be measured with the available equipment it may be necessary for the applicant to demonstrate compliance. Vehicles where the distance between the outermost edges of the tyres exceeds 1.9m should not be tested using a rollerset.</p> <p>Note 1: The speedometer must be of a type suitable for vehicle use. This may be digital or a dial instrument. The types manufactured for bicycles, racing only, those that rely on GPS or those that require switching as a separate function to that of operating the vehicle or those that have a separate power source from the vehicle or where they do not operate as an automatic function when the vehicle is driven are not permitted. Where the device is in question the presenter may provide evidence as to the suitability of the device for road use from the manufacturer of the device.</p>	<ol style="list-style-type: none"> 1. The vehicle must be fitted with an acceptable type of Speedometer (see Note 1). 2. A speedometer must be capable of indicating the vehicle speed in miles per hour (mph). A dial instrument must be marked at uniform intervals not exceeding 20mph for all speeds up to the maximum design speed of the vehicle (see Note 2). 3. The speedometer must be capable of being read at all times of the day or night (see Note 7). 4. The speedometer must not indicate a speed less than the true speed. 5. The speedometer must not indicate a speed that is in excess of the true speed plus the permitted tolerance in the chart below (see Note 3 & Note 6). <table border="1" style="margin-left: auto; margin-right: auto; border-collapse: collapse; text-align: center;"> <thead> <tr style="background-color: #e0e0e0;"> <th style="padding: 5px;">Indicated Speed (mph)</th> <th style="padding: 5px;">Min True Speed (mph)</th> </tr> </thead> <tbody> <tr><td style="padding: 2px 5px;">35</td><td style="padding: 2px 5px;">29</td></tr> <tr><td style="padding: 2px 5px;">40</td><td style="padding: 2px 5px;">34</td></tr> <tr><td style="padding: 2px 5px;">45</td><td style="padding: 2px 5px;">39</td></tr> <tr><td style="padding: 2px 5px;">50</td><td style="padding: 2px 5px;">43</td></tr> <tr><td style="padding: 2px 5px;">55</td><td style="padding: 2px 5px;">48</td></tr> <tr><td style="padding: 2px 5px;">60</td><td style="padding: 2px 5px;">52</td></tr> <tr><td style="padding: 2px 5px;">65</td><td style="padding: 2px 5px;">57</td></tr> <tr><td style="padding: 2px 5px;">70</td><td style="padding: 2px 5px;">61</td></tr> </tbody> </table>	Indicated Speed (mph)	Min True Speed (mph)	35	29	40	34	45	39	50	43	55	48	60	52	65	57	70	61
Indicated Speed (mph)	Min True Speed (mph)																		
35	29																		
40	34																		
45	39																		
50	43																		
55	48																		
60	52																		
65	57																		
70	61																		

Speedometer and Reverse Gear 17

Method of Inspection	Required Standard
<p>Note 2: It is acceptable if the maximum speed of the vehicle is indicated by the last increment on the speedometer which must not be more than 19mph beyond the last 20mph increment.</p> <p>Note 3: The permitted Tolerance is:</p> $\frac{\text{true speed}}{10} + 2.5 \text{ mph}$ <p>Note 4: Many modern vehicles have a self-check feature on startup (ignition on) and Examiners should ensure this function is performed and the vehicle is in a 'ready to drive away' state before applying the Required Standards. If the speedometer needle, when viewed directly in front of the instrument remains below zero after any self-check has been performed and the vehicle is ready to move away, then it would not comply with RS6.</p> <p>Note 5: "Reverse Gear" A device used to propel the vehicle in a backwards direction under its own power, this does not have to be in the gearbox, it may be a separate component i.e., secondary gearbox / electric motor</p> <p>Note 6: DVSA examiner to refer to the DVSA Technical Work Instructions WI-17-01 Speedo Test when carrying out this test.</p> <p>Note 7: While the vehicle speed indication must always be readable, the speed unit descriptor need not be illuminated. It will be deemed acceptable if the descriptor can be read in natural light (i.e., outdoors).</p>	<ol style="list-style-type: none"> 6. The in use "rest" position for the needle of a dial type must be between the Zero position and the first marked increment (see Note 4). 7. The vehicle must have an operational reverse gear which can be selected from the driving position (see Note 5).

Speedometer and Reverse Gear 17

Record of Revision

Revision	Date	Description of Change
1	18/04/2011	Version 1
2	31/07/2011	Insert new Note 5
3	05/10/2015	Update hyperlink in Note 5, add new Note 6 linked from RS3
4	01/09/2020	RS 2 & 6 and Notes 1 & 6 expanded.
5	22/05/2023	Align permitted speed tolerance in Note 4 with UNECE R39.01 and revise table in RS6.
6	09/10/2024	New Note 4 referenced from RS 6; subsequent notes renumbered. (TSE N1 017 003). Note 6 revised & added missing reference to Note 6 from RS 5.

This page intentionally left blank

18 Statutory Plates

Application: All Vehicles

Method of Inspection	Required Standard		
<p>Where the vehicle is subject to a multistage build, a plate is required on completion of each stage as appropriate. Every plate fitted must display the same VIN as displayed on the chassis. The weight information is only necessary on the chassis manufacturer's plate or on a converters plate if they have altered those weights with any modification. Separate plates should be fitted in close proximity to each other.</p> <p>Check that the manufacturer's plate (in the case of a multistage build, one for each stage) complies with the Required Standards.</p> <p>The manufacturer may give additional information. The approval number and build stage number may be listed below the manufacturer's name and the number of axles may be listed underneath the VIN number. Any other information must be outside a clearly marked rectangle which shall enclose only the listed information.</p> <p>If any of the technically permissible masses are higher than the masses permitted in GB and NI for a vehicle or axle, then there should be 2 columns for masses - in the left hand column the maximum permitted masses in GB/NI, and in the right hand column, the technically permissible masses.</p>	<ol style="list-style-type: none"> 1. The vehicle must be fitted with a manufacturer's plate, in a conspicuous and readily accessible position. 2. The manufacturer's plate must be fitted for each stage of a multistage build and be positioned in close proximity to each other. 3. The manufacturer's plate(s) must be made of a durable material 4. The manufacturer's plate(s) must be securely attached to a part of the vehicle that will not be replaced through normal use (see Note 2). 5. The manufacturer's plate(s) must be indelibly marked with the manufacturer's name (see Note 1). 6. The chassis manufacturer's plate must include the required vehicle masses as detailed in the diagram below. <div style="margin-top: 20px; border: 1px solid black; padding: 5px;"> <table style="width: 100%; border-collapse: collapse;"> <tr> <td style="width: 50%; text-align: center; vertical-align: top;"> DVSA MOTOR INC e1*2007/46*0291*02 3GPG918009BS51312 3500 kg 5200 kg 1 – 1500 kg 2 – 2400 kg </td> <td style="width: 50%; vertical-align: top; padding-left: 10px;"> Name of manufacturer Approval No. and/or Build Stage No. Vehicle Identification Number Maximum permitted laden mass of vehicle Maximum permitted laden mass for the combination where the vehicle is used for towing Maximum permitted laden road mass for each axle, listed in order from front to rear </td> </tr> </table> </div>	DVSA MOTOR INC e1*2007/46*0291*02 3GPG918009BS51312 3500 kg 5200 kg 1 – 1500 kg 2 – 2400 kg	Name of manufacturer Approval No. and/or Build Stage No. Vehicle Identification Number Maximum permitted laden mass of vehicle Maximum permitted laden mass for the combination where the vehicle is used for towing Maximum permitted laden road mass for each axle, listed in order from front to rear
DVSA MOTOR INC e1*2007/46*0291*02 3GPG918009BS51312 3500 kg 5200 kg 1 – 1500 kg 2 – 2400 kg	Name of manufacturer Approval No. and/or Build Stage No. Vehicle Identification Number Maximum permitted laden mass of vehicle Maximum permitted laden mass for the combination where the vehicle is used for towing Maximum permitted laden road mass for each axle, listed in order from front to rear		

Statutory Plates 18

Method of Inspection	Required Standard
<p>The identification number of the base vehicle (VIN) prescribed by Directive 76/114/EEC shall be retained during all the subsequent stages of the type-approval process to ensure the 'traceability' of the process. However, at the final stage of completion, the manufacturer concerned by this stage may replace, in agreement with the approval authority, the first and second sections of the vehicle identification number with his own vehicle manufacturer code and the vehicle identification code if, and only if, the vehicle has to be registered under his own trade name. In such a case, the complete vehicle identification number of the base vehicle must not be deleted.</p> <p>Note 1: For markings to be considered 'indelible' they should be unlikely to become disfigured or obliterated during the life of the vehicle. Whilst stamping or engraving is preferable it is possible to accept a printed or painted plate providing it has been treated in such a way that it is most unlikely that essential information would be obliterated or defaced during the normal life of the vehicle.</p> <p>Note 2: 'Securely attached' means screwed, bolted, riveted, or otherwise fixed such that it is not likely to become displaced during the life of the vehicle.</p> <p>Note 3: The spacing of characters must be such that no additional characters could be added at a later date.</p> <p>Note 4: Every plate fitted must display the same VIN as displayed on the chassis.</p> <p>Note 5: For mass produced vehicles the use of two lines is permissible if originally applied by the manufacturer.</p> <p>Note 6: For mass produced vehicles, if originally applied by the manufacturer, it may be less than 17 but not less than 8 digits.</p> <p>Note 7: For mass produced North American Vehicles approved with either FMVSS or CMVSS no stamped in VIN is required, a visible VIN seen through the windscreen will be acceptable,</p>	<ol style="list-style-type: none"> 7. All plate(s) must be indelibly marked with the Vehicle Identification Number (VIN) which matches the number marked into the vehicle structure and is displayed in the correct order inside a clearly marked rectangle (see above and Note 1). 8. The Stamped in VIN must be marked on the chassis, frame or other similar structure, which is not easily removable, on the right hand side of the vehicle when viewed from the rear (see Notes 7, 8 & 11). 9. The Stamped in VIN must be placed in a clearly visible and accessible position by a method such as hammering or stamping so that it cannot be obliterated or deteriorate. 10. The VIN number must consist of 17 digits with the information shown in a single line (see Notes 5 & 6). 11. Capital letters and numerals must be used for the VIN 12. There must not be any gaps between the characters for the VIN or unique vehicle identifier number shown on the manufacturer's plate or stamped into the vehicle (see Note 3). 13. The Vehicle Identification number on the manufacturer's plate must be marked in characters at least 3.5mm high. 14. The characters on the manufacturer's plate (with the exception of the Vehicle Identification Number) must be at least 2mm high. 15. The characters used for the VIN number stamped into the chassis, frame or other similar structure must be at least 3.5mm high. 16. Use of the letter I, the letter O, the letter Q, dashes, asterisks, and other special signs are not permitted (see Note 9).

Method of Inspection	Required Standard
<p>Note 8: For mass produced vehicles any location is accepted if originally applied by the manufacturer</p> <p>Note 9: For mass produced vehicles the use of asterisks and other signs is permitted if originally applied by the manufacturer.</p> <p>Note 10: For instances where the VIN has been changed in accordance with the Approval Authority</p> <p>Note 11: Where the 'stamped in VIN' is stamped on to a separate metal plate it must be secured to the frame by a continuous seam weld around the entire length of the plate; tack or spot welding should not be considered an appropriate method of attachment for such a plate. To stamp the number into a tubular chassis member it is not always practical, however there may be instances where it could be stamped in another similar part of the vehicle structure which is not easily removable.</p>	<p>17. In instances where the VIN has been changed evidence of agreement with the Approval Authority must be provided.</p> <p>18. The original complete vehicle identification number of the base vehicle must be present on the chassis (see Note 10).</p> <p>19. The complete new VIN must be stamped on the chassis as near as possible to the original VIN (see Note 10).</p> <p>20. The last eight characters of the new VIN must be identical to the last eight characters of the base vehicle VIN (see Note 10).</p>

Record of Revision

Revision	Date	Description of Change
1	18/04/2011	Version 1
2	31/10/2011	Revise RS4, RS5 & RS6 and renumber remainder
3	31/05/2012	Revise RS 6 & 12 and correct RS 7
4	04/03/2013	Amend Mol, paragraph 3, remove RS4, insert new RS5 and amend RS6
5	05/10/2015	Amend RS5 – 8, 10 & 12, insert new RS13 & renumber remainder
6	03/04/18	Insert new RS 6 to align with regulations, renumber remaining RS. New Note 11.

19 Seat Belt Anchorages

Application: Vehicles subject to Basic requirements

Method of Inspection	Required Standard
<p>Ensure each seating position is fitted with the required number of anchorage points. Assess the anchorage positioning, their strength, and that of the surrounding vehicle structure</p> <p>The required standards do not apply to seats intended for use solely while the vehicle is stationary or for when the vehicle is not used on a public road.</p> <p>(Any seats which are not for use when travelling on a public road must be clearly identified to users by means of a pictogram or a sign with appropriate text.</p> <p>Note 1: Where the vehicle has two driving positions both must meet the minimum anchorage requirements, and the second seat satisfies the requirement for the foremost outboard passenger seat.</p> <p>Note 2: The front centre seat will require 3 anchorages and a 3-point belt where the windscreen is located;</p> <p>a) in the case of a fixed (non-sliding) seat, within 840mm. of the seat reference point</p> <p>or</p> <p>b) in the case of a sliding seat, within 840mm. of the seat reference point when the seat is 127mm forward of its rearmost position. (see Annex 3).</p>	<ol style="list-style-type: none"> 1. The drivers seating position must have a minimum of 3 anchorages (see Note 1). 2. The foremost outboard passenger seating position must have a minimum of 3 anchorages 3. A front centre seating position must have a minimum of: <ol style="list-style-type: none"> a. 2 anchorages or b. 3 anchorages (see Note 2) 4. Rear seating positions must have a minimum of 2 anchorages if required to be fitted with seat belts (see Note 3). 5. The seat belt anchorage must be correctly located so to ensure the belt will sit correctly on the wearer. 6. Seats which are not intended for use when the vehicle is driven on public road must be accompanied with a pictogram or sign clearly indicating that the seat is not to be used whilst the vehicle is in motion. 7. The anchorage and surrounding structure must be of adequate strength to withstand the load likely to be imposed in the event of a vehicle frontal impact. Spreader plates, where fitted, must be of adequate size and radiused to 2.5mm (see Note 4 and Annex 2).

Seat Belt Anchorages 19

Method of Inspection	Required Standard
<p>Note 3: Seats require a minimum of 2-point anchorage if they are exposed, i.e., if there is no screen in front of a seat. The screen being no more than 1.3m in front of the H point wide enough to be at least 200mm either side of the H point and high enough to reach 400mm above the H point. The surface area of the screen must be at least 800cm². A screen or seat forming a screen must meet the following conditions:</p> <p>a) The surface must be of suitable strength and showing no discontinuities such that, if a sphere of 165 mm diameter is geometrically projected in a longitudinal horizontal direction through any point of the space defined above and through the centre of the sphere, nowhere in the protective screen is there any aperture through which the geometrical projection of the sphere could be passed.</p> <p>b) A seat is considered to be an ‘exposed seating position’ if the protective screens within the space defined above have a combined surface area of less than 800 cm².</p> <p>In the case of Armoured vehicles exemption from any requirement of this item is permitted if it can be demonstrated to the satisfaction of the Approval Authority that it is impossible for the vehicle to comply due to its special purpose.</p> <p>Note 4: Seat belt anchorage points must comply with the strength and location requirements of Directive 76/115 EEC, or to an equivalent safety standard. On seats to which seat belts are directly mounted (integral seat belts) consideration must be given to the seat mounting as a belt anchorage point. Where spreader plates are fitted to seat or seat belt mountings, they must be of adequate size and radiused to a minimum of 2.5mm. The radius must be presented towards the floor of the vehicle to prevent tearing in the event of frontal impact.</p>	

Annex 1 - Strength of seat belt anchorages.

Seat belt anchorages must comply with the strength requirements for N1 vehicles in Directive 76/115/EEC
This can be demonstrated in several ways:

1. Evidence of type approval
2. Documentary evidence of testing to the Directive standard
3. Comparison with a type approved vehicle
4. Visual assessment

1. Evidence of type approval

Suitable evidence of type approval will be accepted.

2. Documentary evidence of testing to the Directive standard.

Suitable documentary proof will be accepted.

3. Comparison with a type approved vehicle

Evidence that the vehicle is of identical structure to a vehicle which has been demonstrated to comply with the requirements or which is type approved may be used to confirm compliance.

4. Visual Assessment

In the absence of evidence, the examiner will have to determine whether the vehicle complies using a visual inspection. See Annex 2

Annex 2 - Seat Belt Anchorages Strength Assessment

In a severe accident, the seated occupant can exert huge loads upon their seatbelts (in the region of 1.5 tonnes for a 75kg person). Seatbelt anchorages together must withstand these large loads from the seatbelts. These loads in turn must be dissipated by the vehicle structure.

In assessing the strength of the anchorages, it is essential to consider

- the vehicle structure in the immediate vicinity of the anchorage, and
- the parts of the vehicle structure into which the loads from the anchorages will be dissipated.

These large loads will act in several directions.

All Vehicles

What to look for:

- Evidence that anchorages in a vehicle of the same or a very similar type have been subjected to a seatbelt anchorage strength test to “European Standards” by a recognised authority. This may be acceptable where there is clear evidence that the structure is identical to the vehicle originally tested.
- Welding should appear neat and of good quality; whilst it is impossible to judge the quality of a weld just by looking at it, messy welding is rarely strong welding.
- Bolts used in structural areas should be of grade 8.8 or better. Such bolts will be marked 8.8 or 12.9 on the hexagonal head, however, cap-head bolts or 7/16" (11mm) UNF seat belt anchorage bolts (with an anodised finish) not marked in this way may normally be considered to be of equivalent strength. Bolts should be M8 or larger.
- Threaded bushes should be welded (at both ends) through the tube, and not end mounted on the surface. (A threaded bush may be attached by its side surface to a structural component).

Cause for Concern:

- Welds of poor appearance, gaps, or visible lack of penetration.
- Anchorages in thin and/or flat panels with little stiffness or reinforcing structure or in thin walled tube.
- Low grade bolts (less than grade 8.8).
- Insufficient bolt capacity, e.g., number of bolts and/or diameter of bolts

What to look for:

General requirements for all vehicles

- A test certificate from a recognised test authority must be provided to show that the seat itself or the seat and tracking (where this is fitted) is capable of meeting the strength and anchorage positional requirements of the Directive 76/115/EC as amended. It should typically include at least the following information:

Seat make and model, Vehicle category (N2 or N3), Seat type (single/double or triple), Belts fitted (3-point or lap), Pedestal height, Mounting details (i.e., on tracking or rigidly, mounted to a base plate).

- **ALL** the mounting holes provided in each pedestal for securing the seat to the vehicle or tracking must be utilized.
- **ALL** the mounting holes provided to secure any given length of tracking to the vehicle must be utilised.
- All tracking fasteners should be M8 grade 8.8 or better.
- tracking must be installed in a
- continuous length without joints.
- Seat or tracking mounting bolts that pass through hollow section reinforcing members should be fitted with “anti-crush tubes”.

NOTE: Alternative mounting arrangements will be considered satisfactory where satisfactory documentary evidence of compliance can be provided by the vehicle presenter.

Fixed Single Seats

A typical single seat fixed directly to the vehicle floor is likely to require

- load spreading plates at least 100 x 100 x 4mm thick.
- spreader plates fitted between the front legs and the **inside** of the vehicle floor
- spreader plates between the rear leg securing nuts and the **underside** of the vehicle floor.

Where the rear mounting bolts are located within 50mm of a chassis member, the plate may be folded (not reduced in size) to clear the obstruction and the fold should abut snugly against the chassis member.

Where two or more single seats each having separate pedestals are mounted within approximately 200mm of each other, additional reinforcement should be provided as well as the load spreading plates, or the size and thickness of the load spreading plates increased.

Seat Belt Anchorages 19

NOTE: In many cases the mounting bolts will pass through slotted holes in the load spreading plate to allow for adjustment. Suitable arrangements must be in place (e.g., oversized washers) to prevent the nut or the head of the bolt from pulling through the slot in the plate.

Single seats with integral 3-point belt anchorages attached to the vehicle floor via offset or asymmetrical legs (i.e., to clear a wheel arch,) must be considered on a case-by-case basis. Documentary evidence from the seat manufacturer should be sought to confirm that the seat itself can withstand the forces required by the Directive when tested independently of the vehicle on its offset pedestals.

In vehicles modified to allow rear-access for a wheelchair via a ramp to a lowered central floor section having additional seats fitted either side of the lowered floor section, seats are often mounted directly to the floorpan either with very short pedestals or no pedestals at all. It is common for at least some of the original vehicle's belt anchorages to be used in combination with one or more of the anchorages on the new seat. The inspection should take into account the reduced floor loading resulting both from the shorter pedestals and (if applicable) from the relocation of the upper anchorage from the seat backrest to the vehicle pillar.

Where only **one** lower anchorage is attached to the seat, the effects of the asymmetrical loading should be considered.

Some vehicles, e.g., motor homes and ambulances are equipped with swivel seats which may have some or all the belt anchorages attached to the seat itself. Such seats should only be inspected in their position of normal use when travelling.

Removable Single Seats

Removable single seats may be fitted to either

- Low Profile tracking (this can be regarded as any tracking system with a section depth of up to 30mm) or
- "Heavy Duty" tracking (this can be regarded as any tracking system with an overall depth of 30mm or more) or
- dedicated clamping mechanisms attached to the floor of the vehicle.

Low Profile tracking systems

The seat fittings locate in cut-outs in the tracking and lock with either a plunger or "blade" arrangement.

In general, a typical single seat with three-point integral belt anchorages and mounted on a typical pedestal arrangement that is itself Directive compliant is likely to satisfy the Directive requirements as long as the tracking is

- supported in such a way as to prevent excessive distortion of the floor

Low Profile tracking should be secured:

- attached to the vehicle using 8mm (grade 8.8 or better) fasteners 75 approx. rather than approx. 100mm apart.
- either bolted to box or steel channel section and then secured to the vehicle floor or secured by bolts going through the floor and into channel or box sections on the underside of the vehicle.
- (where secured into steel channel sections) secured into channel section of a minimum nominal size of 50x25x4mm which is orientated with the channel flanges facing downwards.

NOTE: The channel ends must be free of sharp edges, which may tear the vehicle floor under load.

Unless the tracking is secured to internal reinforcing members, a check should be made that the same number of fasteners are present above and below the vehicle floor. In cases where a fastener lies above a box section, heat shield, fuel tank or other obstruction, it must pass into an object of similar strength to the other reinforcing members.

- ‘Self-tapping’ screws and ‘riv-nuts’ are not considered as being of equivalent strength (unless documentary evidence can be provided).
- Seats should not be capable of being positioned such that the front or rear edge of either pedestal lies within 200mm of the end of a length of tracking.

Heavy Duty tracking systems.

Although these differ in appearance, they all share the same principal feature – i.e., a much deeper section than the “low profile” tracking systems. These lengths of tracking have sufficient depth of section to resist the large bending loads applied during a seat belt anchorage test. As such, they generally require no reinforcement between themselves and the inside of the vehicle floor and only minimal reinforcement beneath the vehicle floor. Typically, such tracking is not secured at precisely defined intervals so that the converter is free to choose the pitch of the fasteners to miss underfloor obstructions such as chassis members. Often the tracking is secured by pairs of fasteners – one on each side of the centerline, rather than individual fasteners along its centerline.

Heavy Duty tracking should be secured:

- with 8mm grade 8.8 (or better) fasteners at intervals of not more than 250mm.
- with fasteners passing through a mild steel load spreading plate at least 50 x 50 x 4mm thick or an equivalent arrangement.
- such that seats are not capable of being positioned with the front or rear edge of either pedestal within less than 200mm of the first or last group of fasteners securing any length of tracking.

Load Spreading Plates

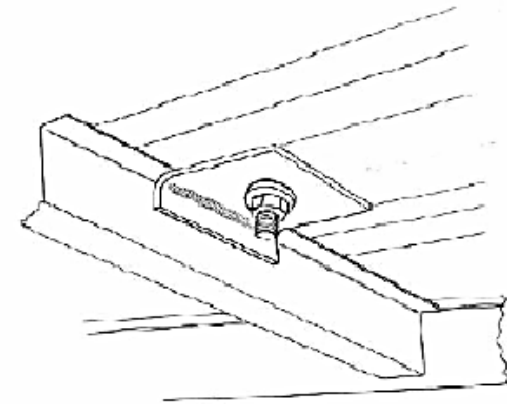
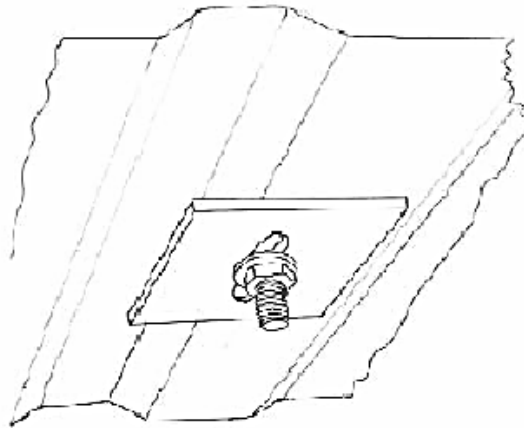
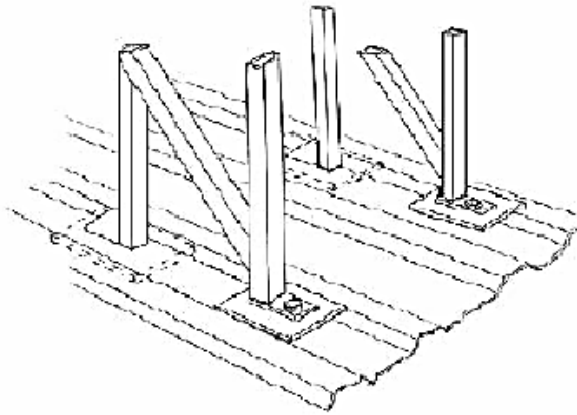

Low Level Tracking

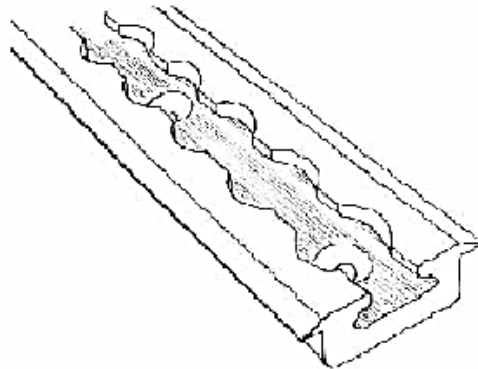

Heavy Duty Tracking

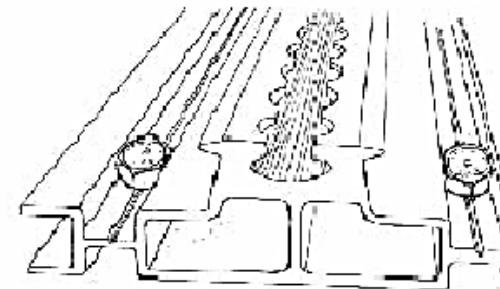

Fixed double seats

Double seats fitted with integral three-point belts and **two or three pedestals** impart significantly higher loads into the vehicle floor than a single seat imparts. As a result, it is extremely difficult to restrain such a seat using simple reinforcements alone. Documentary evidence that the installation can satisfy the Directive requirements **in-vehicle** should be sought.

Where a double seat with integral three-point belt anchorages is fitted with **four or more pedestals**, approximately evenly spaced, a spreader plate extending at least the full width of the seat should be fitted between the front legs and the vehicle floor. Such a plate might typically be in the region of 5mm thick, 150mm long and at least the width of the complete seat (including cushions).

Angle or channel sections of similar or greater rigidity than the flat plate may also be used.

Where two pedestals are mounted within approx. 200mm of each other, additional reinforcement must be provided as well as the load spreading plates, or the size and thickness of the load spreading plates increased.

Removable double seats

Removable double seats with three point integral belt anchorages are rare. In general, such a seat fitted with two or three pedestals is unlikely to satisfy the Directive requirements in a vehicle as most currently available tracking systems will not withstand the loads required for a category "M1" vehicle. In all such cases, documentary evidence that the complete seat and tracking assembly has been successfully tested "in-vehicle" should be sought.

Fixed triple seats

It is common to fit triple seats across the rear of many taxi conversions and "people carrier" vehicles. It is not, generally, possible to secure such seats using simple reinforcements alone. If a triple seat is fitted with three-point integral anchorages, documentary evidence that the complete assembly has been successfully tested "in-vehicle" should be sought.

If some of the belt anchorages are located on the body structure (typically the outboard upper and lower anchorages), the load on the seat mountings will be correspondingly reduced. If the centre seating position is only equipped with a lap belt, the loads on the seat mountings are further reduced. In some cases, only the two anchorages from the centre seat belt and one of the lower anchorages from each of the outboard seating positions will transmit their load into the vehicle through the seat pedestals. Seats fitted with this arrangement of belt anchorages must be assessed on a case-by-case basis. In general terms, such a seat fitted with four pedestals (roughly evenly spaced) is likely to prove satisfactory if fitted with simple load spreading plates. If fewer pedestals are fitted (or more anchorages are located on the seat structure), additional reinforcement will be required.

Rear-Facing seats

Rear-facing single seats with integral belt anchorages are only required to withstand loads approximately **one third** of the magnitude of a forward-facing seat. As such, mounting arrangements can be significantly less substantial than those for forward-facing seats. In many cases, rear-facing seats are mounted on a bulkhead rather than free-standing. Often, the bulkhead structure will be impossible to assess due to the presence of trim on both surfaces. In these instances, drawings or photographs of the structure should be sought. The bulkhead structure should be attached to the vehicle at least along its lower edge and sides. An assessment of the strength and number of such mountings should be made. The examiner must satisfy themselves (as far as is reasonably practicable) that the attachment(s) of the bulkhead to the vehicle “B” pillars does not compromise the strength of the front seat upper belt anchorages. An inspection of the method used to attach the belt anchorages to the bulkhead (or seats) should also be made. If the belts are attached to the seats, their attachments to the bulkhead will be part of this inspection. It is common to only fit lap belts on rear-facing seats. The removal of an upper belt anchorage significantly reduces the load at the base of the seat during a test. This should be taken into consideration when assessing the structure.

Seats with integral Lap Belts

The fitting of a lap belt rather than a three-point belt with its upper anchorage on the seat back is likely to lower the loads on the vehicle floor by approximately one third. For a typical “minibus style” single seat, the load acting to pull the rear legs out of the floor when fitted with a three-point belt is likely to be in the region of 6 tonnes. This would reduce to approximately 4 tonnes if the same single seat were to be fitted with an integral lap belt. In view of the reduction in floor loading, less reinforcement is likely to be required than for a seat with three integral anchorages.

NOTE: In cases where three anchorages are provided but only two are attached to the seat, the load on the pedestals could be reduced –till further - possibly by as much as half.

Sliding Seats

Some seats are fitted to a system of “runners” so as to allow fore and aft adjustment or to provide two alternative positions of use. Some of the belt anchorages for such seating positions may be attached to the seat. Before making any assessment of the belt anchorages, documentary evidence should be sought to confirm that the seat and runner assembly is capable of satisfying the requirements of the Directive when tested **independently** of the vehicle. Once this has been confirmed, the installation of the seat in the vehicle can be assessed.

Annex 3

Reference Zone

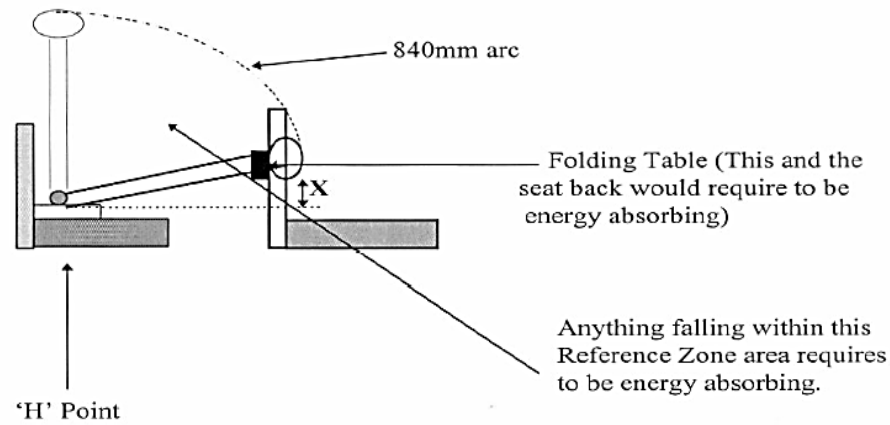
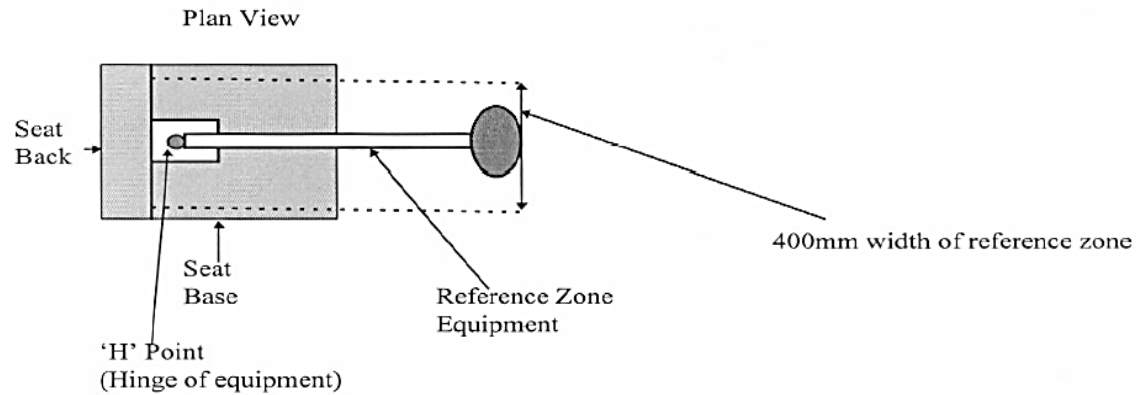

Note :- X = Lower position of the reference zone 25.4 mm above the H point.

Seat Belt Anchorages 19

Record of Revision

Revision	Date	Description of Change
1	18/04/2011	Version 1
2	05/10/2015	Correct note numbering
3	03/04/18	Expand RS7 and add paragraph to MOI Note 4, linked from RS7, correct grammar in RS6.
4	01/09/2020	Correction in Annex 1.

20 Installation of Lights

Application: All Vehicles

Method of Inspection	Required Standard
<p>The examiner will perform a visual check of all lamps and reflectors fitted to the vehicle, for the correct colour light visible to the front or rear and for any obscured surfaces.</p> <p>Exemption from one or more of the technical requirements is permitted for a special purpose vehicle where the special purpose makes it impossible to fully comply provided that all mandatory devices are installed, and geometric visibility is unaffected.</p> <p>Lamp/reflector lateral position is measured from the extreme outer edge of the vehicle (disregarding the deflected part of the tyre walls immediately above the point of contact with the ground, mirrors, lamps and reflectors) to the edge of the illuminated area (or reflective surface on a reflector) nearest that side of the vehicle. Lamp/reflector vertical position is measured from the ground.</p> <p>In the case of the minimum height to the lower edge of the illuminated area (reflective surface on a reflector).</p> <p>In the case of a Dipped Beam headlamp the minimum height will be measured to the apparent trace of the beam cut-off on the lens. If this point cannot be determined, then you will take the lower edge of the illuminated area.</p> <p>In the case of the maximum height to the top edge of the illuminated area (reflective surface on a reflector).</p> <p>In the case of lamp or reflector separation the distance must be measured to the edge of the illuminated area (reflective surface on a reflector).</p>	<ol style="list-style-type: none"> 1. The vehicle must be fitted with lamps or retro reflective material only capable of showing a white light to the front except for: <ul style="list-style-type: none"> • an amber light from a direction indicator • an amber light from a hazard beacon/warning lamp • a yellow light from a front fog lamp • a yellow light from a front end outline marker lamp • an amber light from a side marker light • a red light from a rearmost side marker or rear position lamp • emergency vehicles only, a blue light from a warning lamp or beacon 2. The vehicle must be fitted with lamps or retro reflective material only capable of showing a red light to the rear except for: <ul style="list-style-type: none"> • an amber light from a direction indicator • an amber light from a hazard beacon/warning lamp • a white light from a work lamp, reversing lamp, interior lamp, or a registration plate lamp • a yellow light from a registration plate • an amber light from a side marker light • emergency vehicles only, a blue light from a warning lamp or beacon • Emergency vehicles only, a yellow-green light from a retro reflective material (see Note 2)

Installation of Lights 20

Method of Inspection	Required Standard
<p>Note 2: Vehicles on the public highway that operate or stop for work purposes may display rear chevrons which contain ‘non-reflective’ fluorescent yellow.</p> <p>Note 3: Rear Fog Lamp to Rear Brake Lamp separation distance must be measured between the “illuminating surface” of each lamp. “Illuminating Surface” should be taken to be the area of the “reflector” to the rear of the bulbs.</p> <p>Where lamps are mounted in a common housing and are “E” marked, the separation criteria should be assumed to be met.</p> <p>Note 3: The brightness of lamps bearing an appropriate approval mark defines the acceptable standard. Lamps not bearing such a mark should emit light of similar brightness.</p> <p>Note 4: Headlamps should not be compared for brightness but should emit sufficient light to illuminate the road in front of the vehicle on both main and dipped beams.</p> <p>Note 5: Lamp security - Lamps must be securely mounted to the vehicle, double-sided tape as a method of attachment is to be considered acceptable only in situations where it is the manufacturer's intended method</p> <p>Note 6: Lamp position. Achieving position requirements by masking external parts of the illuminated area is not acceptable. However, except for headlamps, internal masking or internal painting of lamp lenses is permitted but this must be permanent and must not affect lamp intensity.</p> <p>Note 7: Interpretation of the term IMPRACTICABLE/IMPRACTICAL when used in the context of lamp [reflector] position (e.g., “900 or if impracticable 1500”) shall be in line with the following: It shall be deemed impractical to comply with a requirement to mount lamps</p>	<ol style="list-style-type: none"> 3. The operation of any lamp must not affect any other lamp or be affected by the operation of any other lamp, unless specifically designed to do so. 4. All obligatory and optional lamps and reflectors must be securely fitted to the vehicle and not move by swivelling, deflecting or otherwise while the vehicle is in motion, except for: <ul style="list-style-type: none"> • any lamp or reflector which by design can be deflected to the side with the movement of the front wheel or wheels of the vehicle when turned for the purpose of steering the vehicle • a headlamp for adjustment or dipping of the beam • a headlamp which can be retracted or concealed • a work lamp, used to illuminate a working area or the scene of an accident, breakdown, or road works in the vicinity of the vehicle to which it is fitted. 5. All obligatory and optional lamps, reflectors and rear markers must be fitted to their correct orientation. 6. When every door, tailgate, boot lid, or other movable part is in the fixed open position (any movable component, with or without a light-signalling device installed on it, in any fixed position (see Note 9) different from the ‘normal position of use’) each of the: <ul style="list-style-type: none"> • front and rear position lamps • front and rear indicators • rear retro reflectors <p>must fulfil one of the following conditions:</p> <ol style="list-style-type: none"> a. half (50%) of the apparent surface (see Note 10) of the lamp or reflector is visible from directly in front of / behind (as appropriate) the vehicle, or

Installation of Lights 20

Method of Inspection	Required Standard
<p>[reflectors] where no vehicle structure is available for them to be mounted on. On a mass-produced vehicle, it shall be deemed impracticable to comply with a requirement that involves moving lamps [reflectors] from their original positions as fitted by the mass production vehicle manufacturer.</p> <p>Note 8: For the purposes of the test, lamps that are intended to illuminate the road forward of the vehicle are considered to be either:</p> <ul style="list-style-type: none"> a. main beam headlamps (including spot lamps and driving lamps) b. dipped beam headlamps, or c. front fog lamps. <p>Note 9: Fixed position of a movable component means the stable or natural rest position(s) of the movable component which can be specified by the manufacturer, whether locked or not.</p> <p>Note 10: If a plastic cover over the lamp unit is of a permanent fixing and forms part of the housing of the light unit then this housing will be considered the apparent surface of the lamp</p> <p>Note 11: This does not apply to rear retro reflectors which must be visible at all times.</p> <p>If workshop tools or equipment are required to reinstate the function of a lamp that 'lamp' should be considered not 'fitted'. If a stop lamp meets the criteria of an optional' lamp and is 'fitted', i.e., connected it must meet the requirements of RS8 in Section 22.</p> <p>Two or more lamps (see “A” and “B” in Figure 4, Figures 4a & 4b), whether identical or not, having the same function and emitting light of the same colour are considered to be one lamp if the aggregate illuminated area of the lamps occupies 60% or more of the area of the smallest rectangle circumscribing those illuminated areas, or where the distance between the edges of two neighbouring parts of the apparent</p>	<ul style="list-style-type: none"> b. additional fully visible lamp (s) / reflectors satisfying all requirements for the above lamps / reflectors are activated / visible, or c. a notice in the vehicle must inform the user that in certain positions of the movable components, other road users should be warned of the presence of the vehicle on the road (e.g., by laying out a warning triangle) (see Note 11). <p>7. All lamps must emit light of an equivalent brightness and colour when compared to an e approved lamp of the same type.</p>

Method of Inspection	Required Standard
surface of the illuminated area are less than or equal to 75 mm apart when measured straight from the axis.	

Figure 1

Horizontal Angles of Visibility

Each lamp and reflector must be positioned such as to provide an “apparent surface”. At least 50% of the “apparent surface” of each lamp or reflector must be visible from any point within the relevant angles.

Where the front indicator lamp is positioned less than 750mm from the ground the inward angle of visibility may be reduced to 20° when viewed between the vertical angles of visibility shown in Figure 2 ‘a’

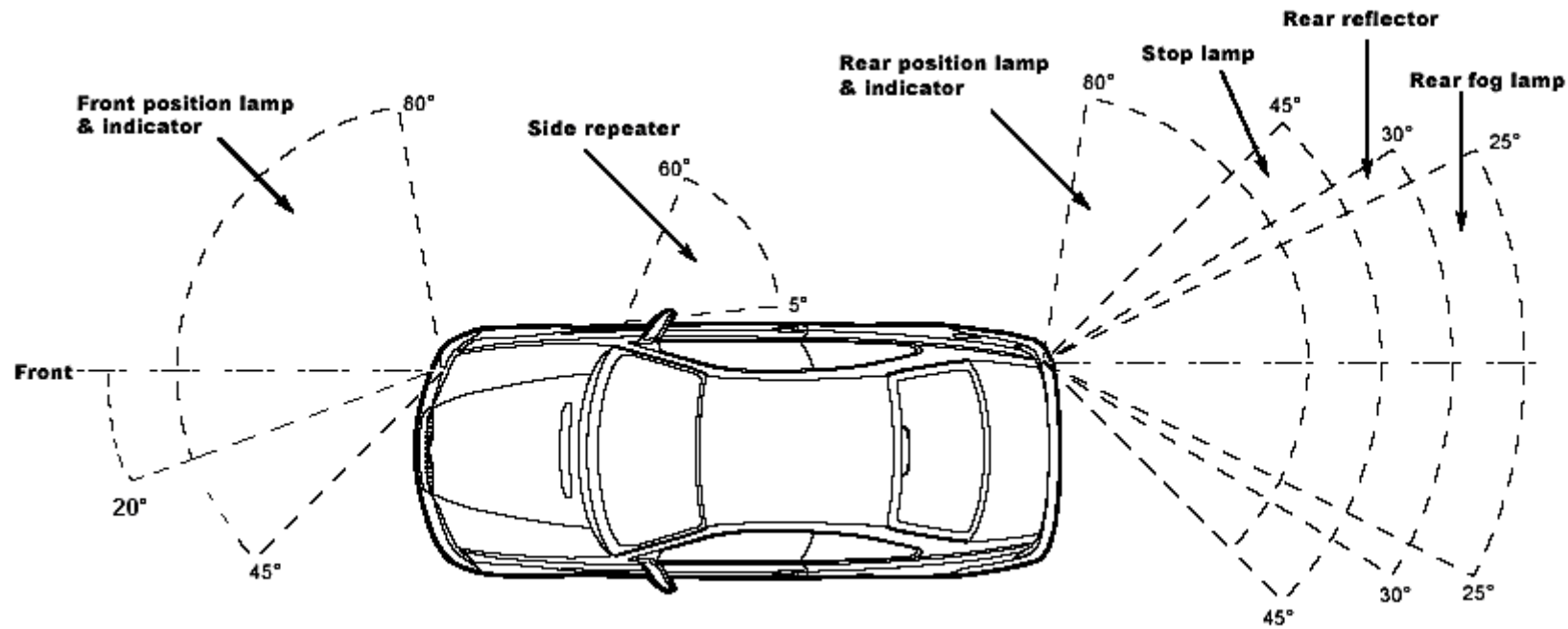

Installation of Lights 20

Figure 1A

On N1 vehicles less than 6 m in length, side-marker lamps may be used to supplement the angles of visibility requirements of front & rear position or indicator lamps where the obligatory lamps do not meet those requirements. Where applicable, these lamps must be fitted as near to the front / rear of the vehicle as possible, and in no case beyond the mid-point of the front / rear wheel arch (see diagram below).

Side marker lamps are permitted to flash providing they are of the type SM1 or SM2 only, and the flashing is in phase with the direction indicator on the same side of the vehicle (see Section 23 for further information).

Where the front indicator lamp is positioned less than 750mm from the ground the inward angle of visibility may be reduced to 20° when viewed between the vertical angles of visibility shown in Figure 2 'a'

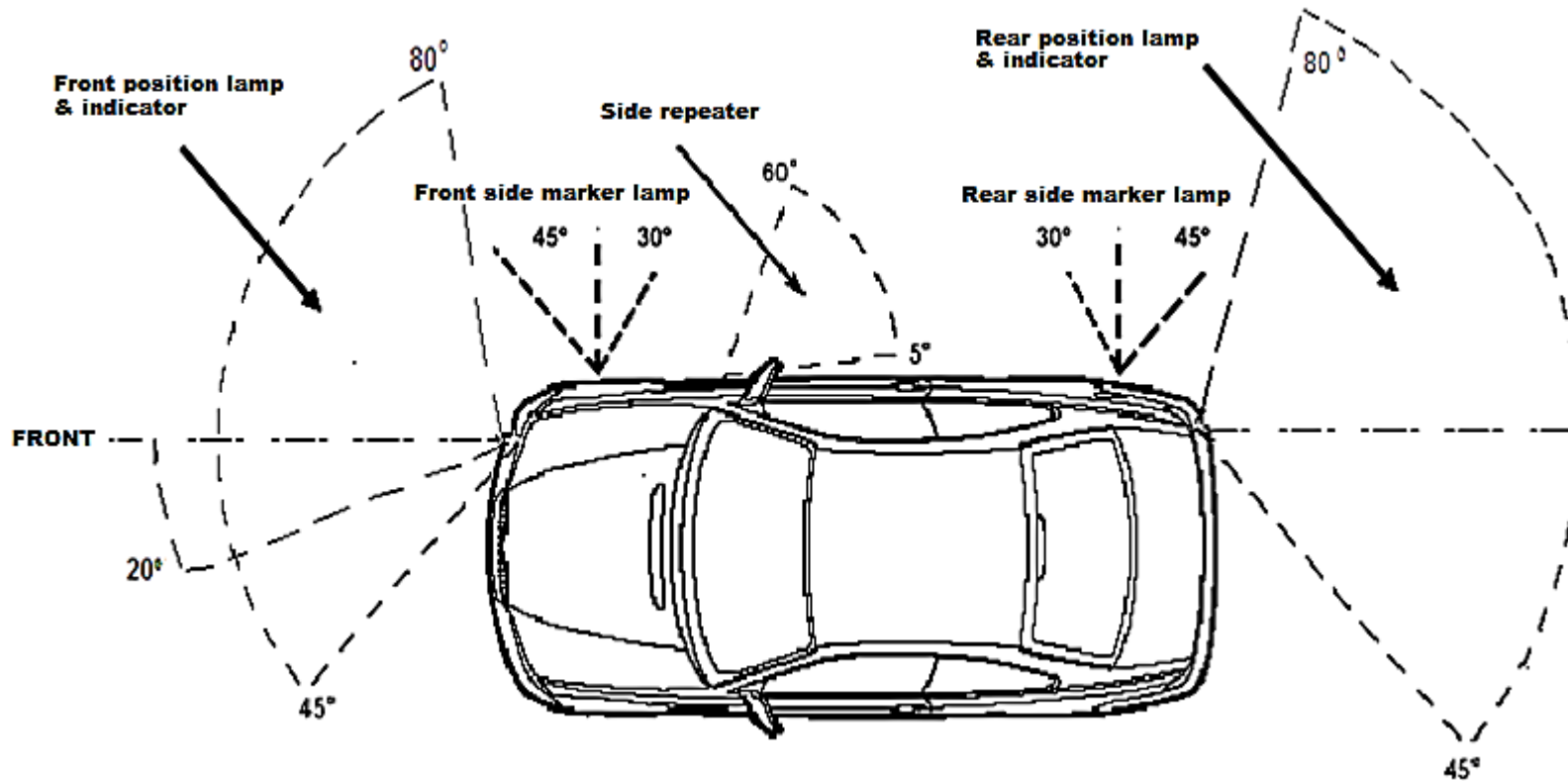

Installation of Lights 20

Figure 2**Vertical Angles of Visibility**

Front Position Lamps and Indicators (including Side Repeaters)

'a' = less than 750mm above ground level.

'b' = 750mm or more above ground level.

'c' = Rear position lamps and Stop lamps 1500mm or more above ground level. Indicators and Rear reflectors 750mm or more above ground level.

'd' = Rear position lamps and Stop lamps less than 1500mm above ground level.

'e' = Rear position lamps, Stop lamps, Indicators and Rear reflectors less than 750mm above ground level.

'f' = Rear fog lamps.

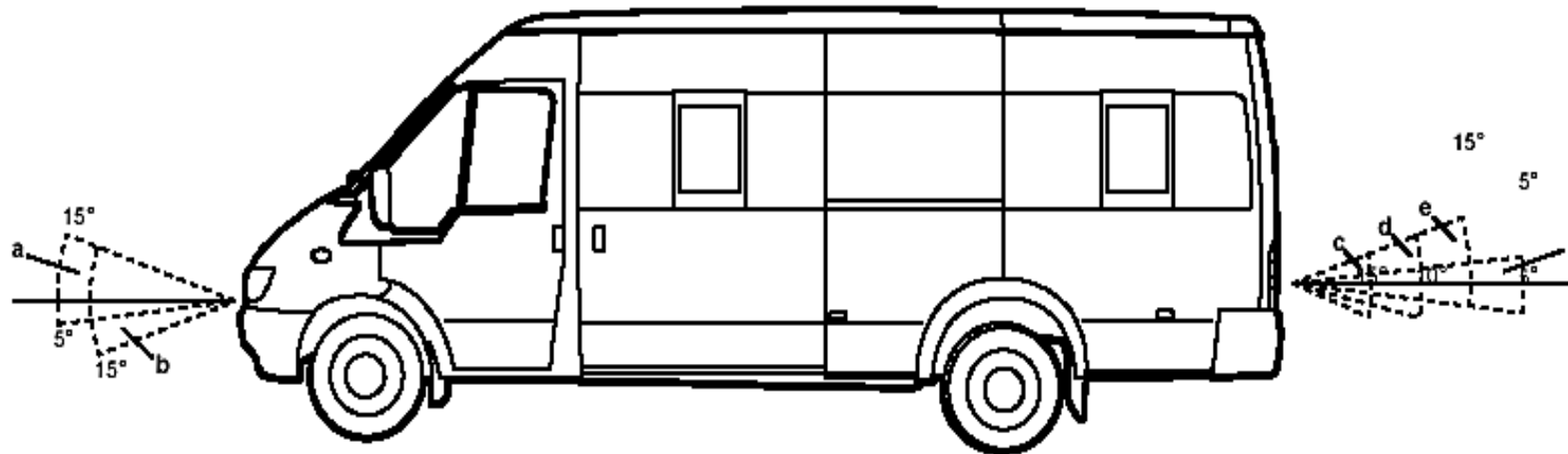

Each lamp and reflector must be positioned such as to provide an “apparent surface”. At least 50% of the “apparent surface” of each lamp or reflector must be visible from any point within the relevant angles shown

Figure 3

“To the rear” of the vehicle means:

If viewed from an observer moving within an area shown in the diagram below (Zone 1), the sides of which are at an angle of 15 degrees out from the extreme outer edge of the vehicle starting from the rear corner and extending up to **25m** from the rear of the vehicle (measured along the vehicle longitudinal), no light other than a red light (with the exception of amber light from a direction indicator, white light from a work lamp, reversing lamp, or a registration plate lamp or yellow light from a registration plate lamp) is permitted to be visible in this area.

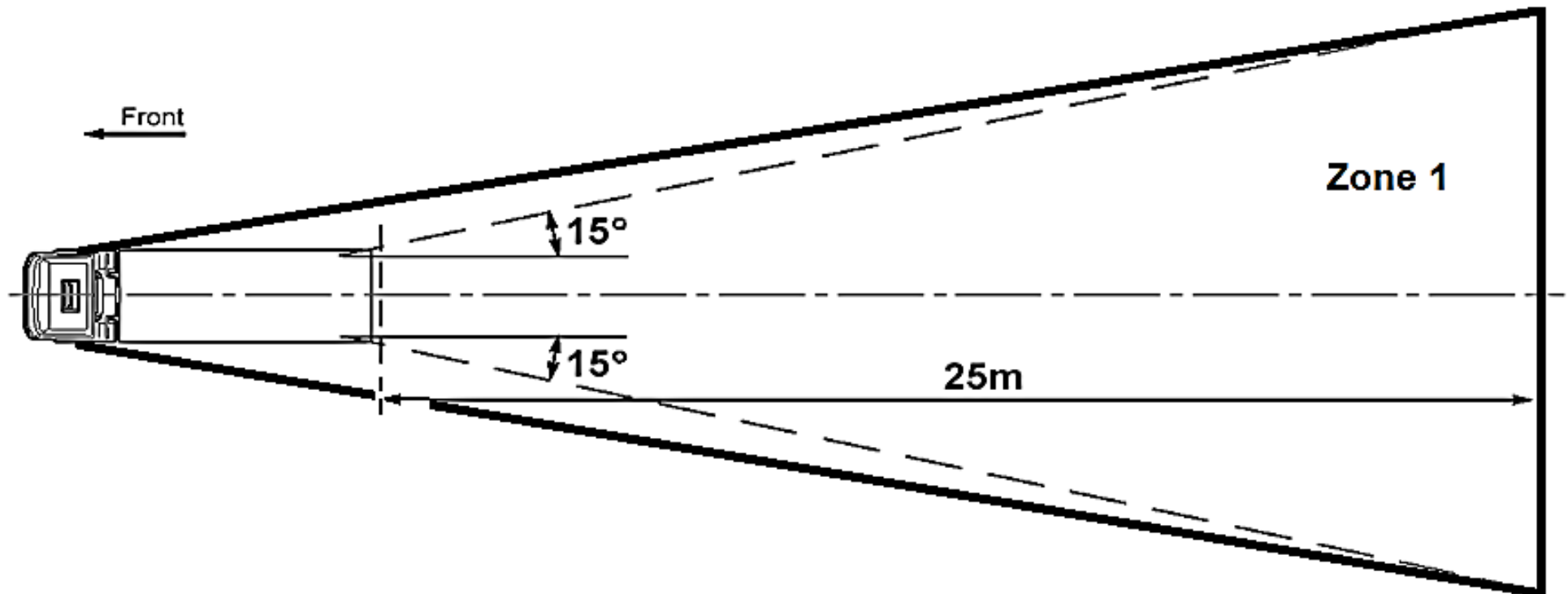

NOTE: 15 degrees at 5m distance = 1330mm. 15 degrees at 10m distance = 2670mm.

Figure 3a

“To the front” of the vehicle means:

If viewed from an observer moving within an area shown in the diagram below (Zone 2), the sides of which are at an angle of 15 degrees out from the extreme outer edge of the vehicle starting from the front corner and extending up to **25m** from the front of the vehicle (measured along the vehicle longitudinal), no light other than a white light (with the exception of an amber light from a direction indicator, an amber light from a hazard beacon/warning lamp, a yellow light from a front fog lamp, a yellow light from a front end outline marker lamp, an amber light from a side marker light, a red light from a rearmost side marker or rear position lamp; and emergency vehicles only, a blue light from a warning lamp or beacon) is permitted to be visible in this area.

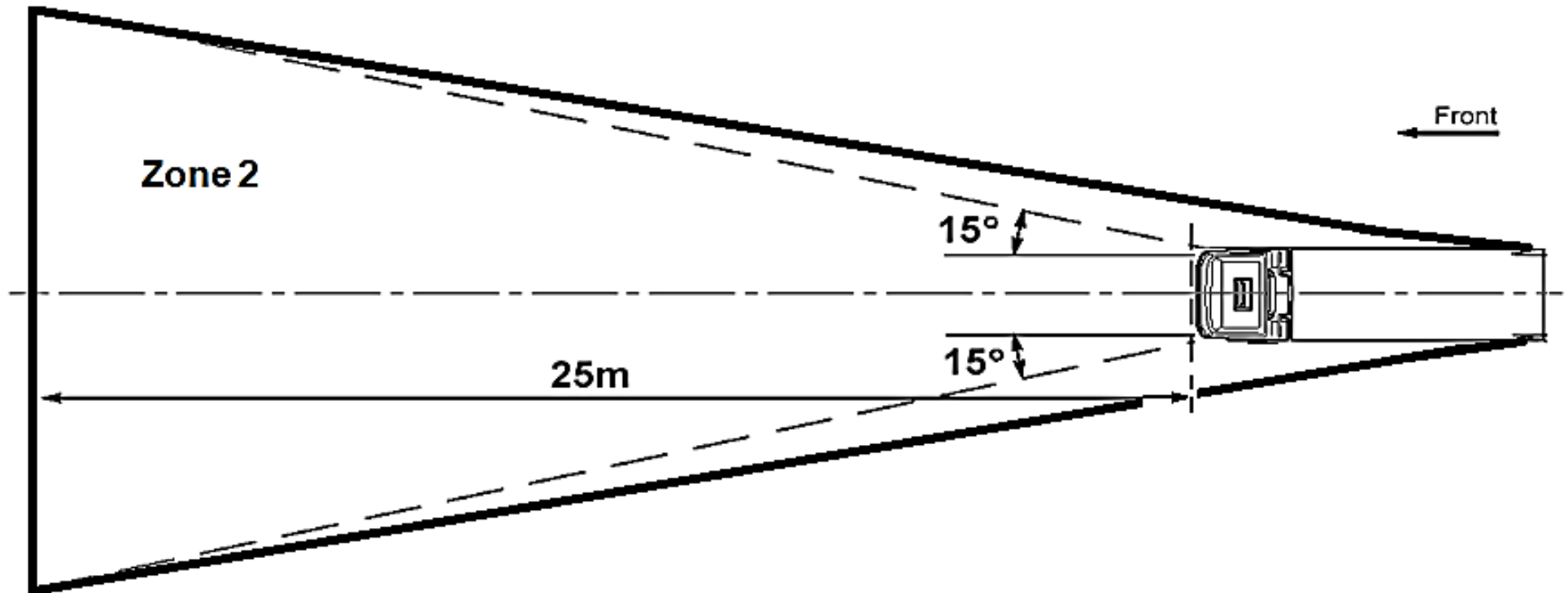

NOTE: 15 degrees at 5m distance = 1330mm. 15 degrees at 10m distance = 2670mm.

Installation of Lights 20

Figure 4

Two or more lamps (see diagrams below), whether identical or not, having the same function and emitting light of the same colour are considered to be one lamp if the aggregate illuminated area of the lamps occupies 60% or more of the area of the smallest rectangle circumscribing those illuminated areas.

If the total of the red area is 60% or more of the area drawn around the lamps, the lamps are considered to be one lamp.

If the total of the amber area is 60% or more of the area drawn around the lamps, the lamps are considered to be one lamp.

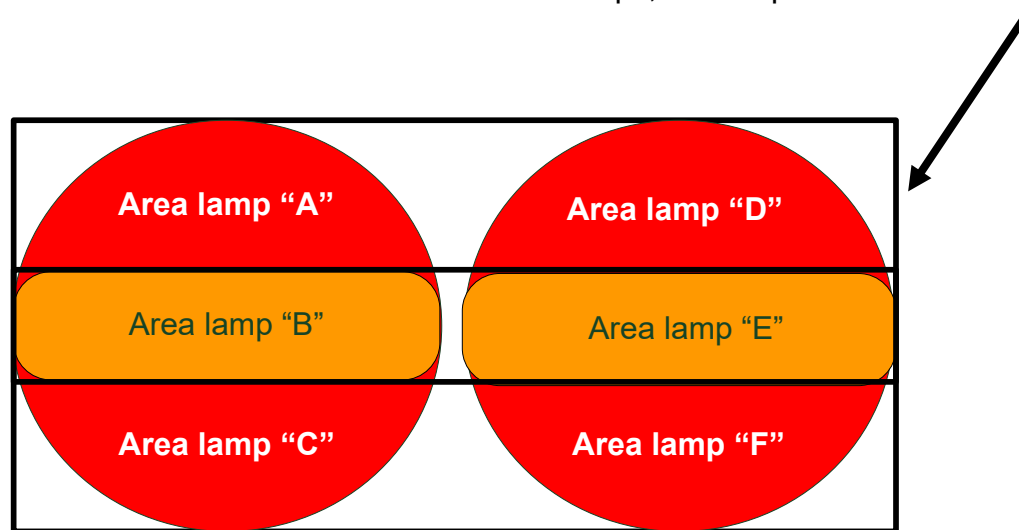

Figure 4a

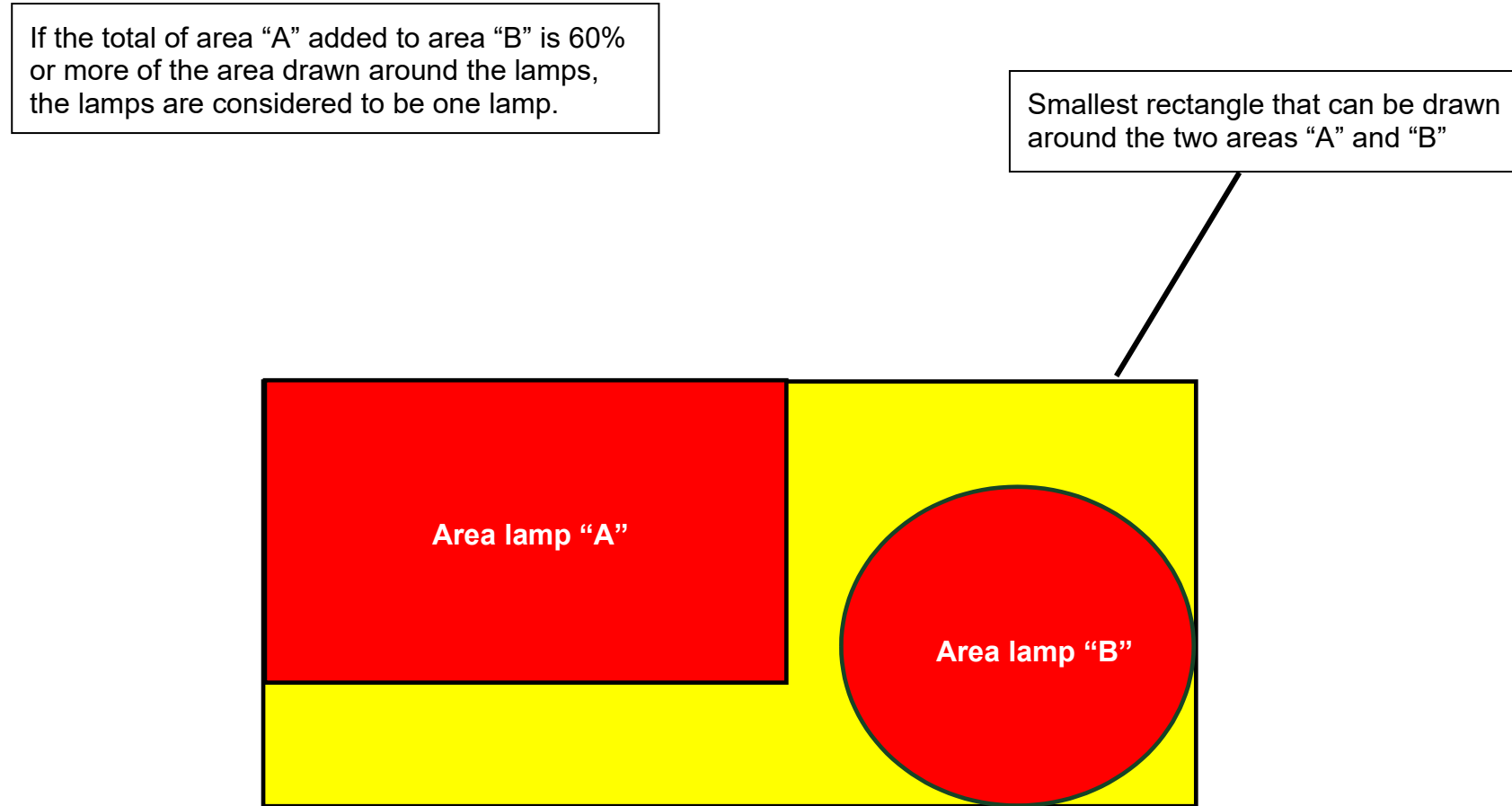
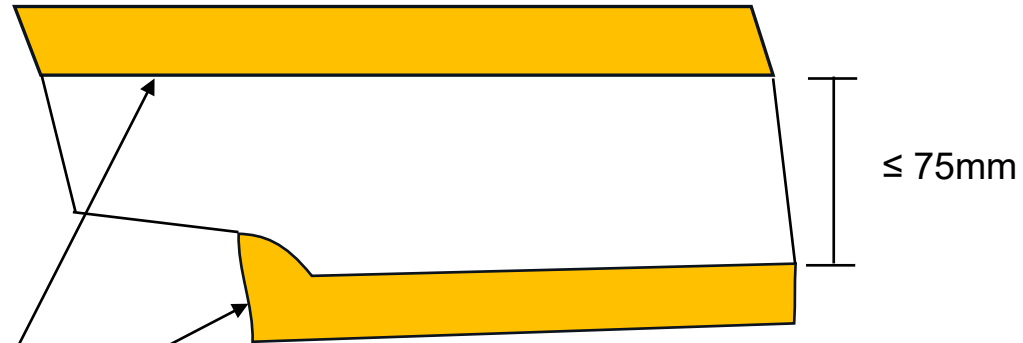

Figure 4b



Example

The Direction indicator is considered to be a single lamp if the distance between the edge of the two neighbouring parts of the apparent surface of the illuminated area are less than or equal to 75mm



Figure 5

The methodology for assessing lamp separation.

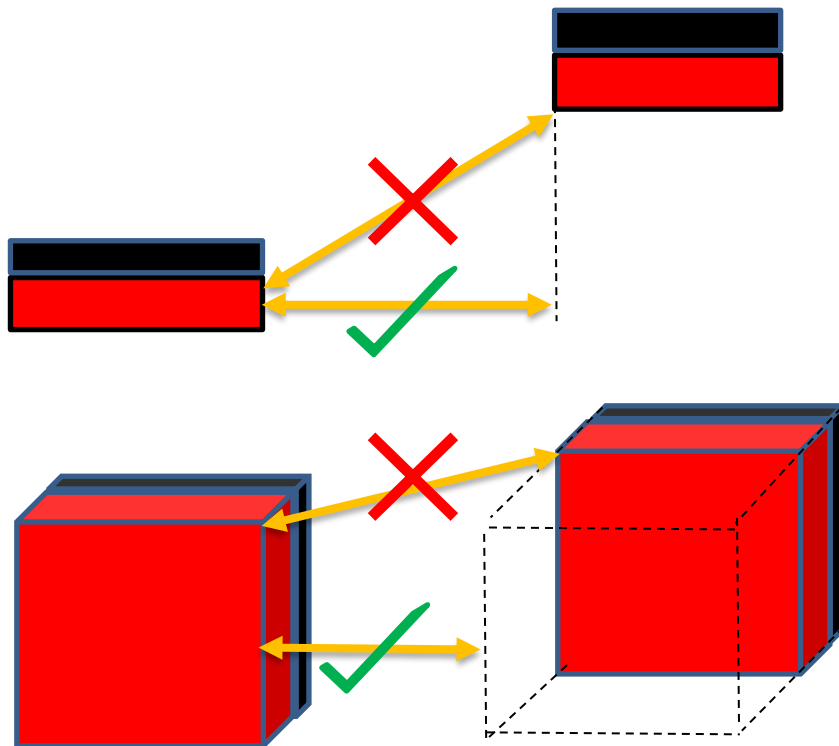

Measuring lamp separation viewed in plan form (from above).

Measuring the same lamp separation viewed in end elevation (directly behind the vehicle)

Example: Reg 48.03 End Outline Marker (6.13.9) requirements:

The position of an end outline marker lamp in relation to corresponding position lamp shall be such that the distance between the projections on a transverse vertical plane of the points nearest to one another on the apparent surfaces in the direction of the respective reference axes of the two lamps considered is not less than 200 mm.

Note: Check each lamp against its specified separation dimension in its section of the manual. This applies equally to Conspicuity Markings.

Record of Revision

Revision	Date	Description of Change
1	18/04/2011	Version 1
2	31/10/2011	Inserted new Note 9, Inserted new bullet points in RS1 & RS2, add link to Note 9 from RS6a, a link to Note 10 from RS 6c, and revise Figure 1, front indicator angles of visibility.
3	31/05/2012	Revise Figure 1A, indicator angles of visibility.
4	11/03/2013	Insert new Note 2 and new bullet point at RS2.
5	05/10/2015	Amend note 10, Insert new paragraphs in Mol, and new Figure 4.
6	01/09/2020	New Figure 5 lamp separation added.
7	22/05/2023	Revise RS1 to include 'red light from a rearmost side marker or rear position lamp. Revise RS6 with reference new Note 9 to clarify 'fixed open position' and renumbering of subsequent notes. Insert additional diagram- Figure 4 and rename existing diagram to 4a. (TSE N1 020 006). Amend Figure 1A text to include reference to flashing side marker lamps. Revise Figure 3 and related text to include 'Zone' area. Add Figure 3a and related text to clarify 'view from the front' (TSE IVA N1 020 007 & TSE IVA N1 022 004).
8	09/10/2024	Revise MOI to clarify consideration of tyres. Paragraph at Figure 1A revised. Revise 'Two or more lamps' paragraph in MOI & add Figure 4b (TSE IVA N1 022 007).

21 Retro Reflectors

Application: All Vehicles

Method of Inspection	Required Standard
<p>Carry out a visual check of all retro reflectors fitted to the vehicle for colour, number, and correct positioning. With optional reflectors check that fitment is permitted</p> <p>Triangular rear reflectors (marked with a III, IIIA or IIIB) are only allowed on trailers, they are prohibited on N1. (Reflectors which are close to a triangular shape but are approved for motor vehicles (marked with I, IA, IB, II, IIA, IIB, IV, IVA, IVB) must be accepted.</p> <p>Note 1: Geometric angles of visibility and positional requirements are not required for all optional reflectors.</p>	<p>Reflectors</p> <ol style="list-style-type: none"> 1. The correct number must be fitted to the vehicle (Table 1) 2. The correct colour must be fitted to the vehicle (Table 1) 3. must be positioned to meet <ol style="list-style-type: none"> a) the positional requirements of Table 1 b) the angles of visibility requirements of Table 1 (see Note 1) 4. must be of the correct shape (Table 1) 5. must have similar characteristics when compared to an 'e' marked reflector 6. Rear reflectors must face predominately to the rear

Table 1

TYPE	NUMBER	APPLICATION	COLOUR	POSITION			ANGLES OF VISIBILITY
				MAX DISTANCE FROM SIDE (mm)	MAX HEIGHT (mm)	MIN HEIGHT (mm)	
Rear Retro Reflectors Non-triangular	Min 2 Max any	Mandatory	Red	400	900 or if impracticable 1500	250	a. Horizontal i. 30° inwards and outwards. b. Vertical i. < 750mm above the ground 15° above and 5° below horizontal. ii. otherwise 15° above and below horizontal
Front Retro Reflectors Non-triangular	Min 2 Max any	Optional but if fitted must be in pairs (for concealed headlamps only)	White	400	900 or if impracticable 1500	250	Must face the front
Side Retro Reflectors Non-triangular	Such that rules are complied with, see below	Mandatory on vehicles exceeding 6m in length. Optional on other vehicles	Amber The rearmost reflector may be red.		900mm if impractical to comply 1500 mm	250	a. Horizontal i. 45° inwards and outwards b. Vertical i. <750mm above the ground 15° above and 5° below horizontal. ii. otherwise 15° above and below horizontal
<ul style="list-style-type: none"> • at least one side-reflector fitted to the middle third of the vehicle • the foremost side- reflector being not further than 3 m from the front • the distance between two adjacent side reflectors shall not exceed 3 m if the structure of the vehicle makes it impossible to comply with such a requirement, this distance may be increased to 4 m • the distance between the rearmost side- reflector and the rear of the vehicle shall not exceed 1 m 							

Retro Reflectors 21

Record of Revision

Revision	Date	Description of Change
1	18/04/2011	Version 1

This page intentionally left blank

22 End-outline, Position (Side), Stop, Side Marker & Daytime Running Lamps

Application: All Vehicles

Method of Inspection	Required Standard
<p>Carry out a visual check of all outline marker, position, stop, side marker and daytime running lamps fitted to the vehicle for operation, colour, number, and correct positioning. With optional lamps check that fitment is permitted, and they do not exceed the maximum number of lamps allowed to be fitted</p> <p>Note 1: The tell-tale must operate with the operation of the position lamp switch, it may be the illumination of the instruments or a separate lamp of any colour (providing it is not likely to confuse the driver) clearly identified in either a pictogram (see section 33) or in a word format.</p> <p>Note 2: The inspection of the side marker lamps applies to the obligatory lamps fitted to all vehicles exceeding 6m in length</p> <p>Note 3: In addition, on N1 vehicles less than 6 m in length, side-marker lamps may be used to supplement the angles of visibility requirements of front position lamps or rear position lamps where the obligatory lamps do not meet the requirements.</p> <p>Note 4: End Outline Marker Lamps</p> <ul style="list-style-type: none"> a. Both front and rear lamps can be combined in one device b. The lights must be a minimum of 200mm from a positional lamp. 	<p>Front and Rear Position Lamps;</p> <ol style="list-style-type: none"> 1. The correct number must be fitted to the vehicle (Table 1). 2. They must be operational. 3. They must only emit white light to the front / red light to the rear. 4. Must be switched on and off by the operation of one switch. 5. Must have a tell-tale fitted (see Note 1). 6. They must be positioned to meet: <ul style="list-style-type: none"> a. the positional requirements of Table 1. b. the angles of visibility requirements of Table 1 (see Notes 3 & 7). <p>Stop Lamps;</p> <ol style="list-style-type: none"> 7. The correct number must be fitted to the vehicle (Table 1). 8. They must be operational. 9. They must only emit red light. 10. They must only illuminate when the service brake is applied and must extinguish when the service brake is released.

End-outline, Position (Side), Stop, Side Marker & Daytime Running Lamps 22

Method of Inspection	Required Standard
<p>Note 5: The inspection of end-outline marker lamps applies to the obligatory marker lamps fitted to vehicles exceeding 2.10m in width</p> <p>Note 6: Daytime running lamps. The lamps must be connected so that they switch off automatically when the headlamps are on. (Except for when the headlamps are flashed).</p> <p>Lamps may be grouped, combined or reciprocally incorporated with one another provided all requirements regarding colour, position, orientation, angles of visibility, electrical connections and other requirements, if any, are fulfilled.</p> <p>Note 7: Geometric angles of visibility and positional requirements are not required for all optional position lamps, end outline marker lamps and stop lamps, however, only one stop lamp is permitted on the vehicle's vertical centre-line.</p>	<p>11. They must be positioned to meet:</p> <ul style="list-style-type: none"> a. the positional requirements of Table 1. b. the angles of visibility requirements of Table 1 (see Note 7). <p>12. Optional stop lamps must face to the rear.</p> <p>Side Marker lamps; (if required or optionally fitted)</p> <p>13. The correct number of mandatory lamps must be fitted to the vehicle if its length exceeds 6m (in accordance with the positional requirements see Table 1 and Notes 2 & 3).</p> <p>14. They must be operational.</p> <p>15. They must emit an amber light (red will be acceptable if within 1 metre of the rear).</p> <p>16. Must be switched on and off by the operation of one switch.</p> <p>17. They must be positioned to meet:</p> <ul style="list-style-type: none"> a. the positional requirements of Table 1. b. the angles of visibility requirements of Table 1. <p>End Outline Marker Lamps; (if required or optionally fitted)</p> <p>18. The correct number of mandatory lamps must be fitted to the vehicle (Table 1 and Notes 4 & 5).</p> <p>19. They must be operational.</p>

End-outline, Position (Side), Stop, Side Marker & Daytime Running Lamps 22

Method of Inspection	Required Standard
	<p>20. They must only emit red light to the rear / white or amber light to the front.</p> <p>21. Must be switched on and off by the operation of one switch.</p> <p>22. They must be positioned to meet:</p> <ul style="list-style-type: none"> a. the positional requirements of Table 1 and Note 4. b. the angles of visibility requirements of Table 1 (see Note 7). <p>Daytime running lamps;</p> <p>23. The correct number must be fitted to the vehicle (Table 1).</p> <p>24. They must be operational.</p> <p>25. They must only emit white light to the front.</p> <p>26. They must be positioned to meet:</p> <ul style="list-style-type: none"> a. the positional requirements of Table 1. b. the angles of visibility requirements of Table 1. <p>27. They must extinguish automatically when headlamps are operated (see Note 6).</p>

End-outline, Position (Side), Stop, Side Marker & Daytime Running Lamps 22

Table 1

TYPE	NUMBER	APPLICATION	COLOUR	POSITION			ANGLES OF VISIBILITY
				MAX DISTANCE FROM SIDE (mm)	MAX HEIGHT (mm)	MIN HEIGHT (mm)	
Front Position Lamps	Min 2 Max 4 (see Note 7)	Mandatory	White	400	1500 or if impractical 2100 See ³ below	250	a. Horizontal i. 45° Inwards ii. 80° Outwards b. Vertical i. 15° Above and below the horizontal (May be reduced to 5° if the lamps are less than 750mm above the ground)
Rear Position Lamps	Min 2 Max 4 (see Note 7)	Mandatory	Red	400	1500 or if impractical 2100 See ³ below	350	a. Horizontal i. 45° Inwards ii. 80° Outwards b. Vertical i. 15° above and below the horizontal (May be reduced to 5° if the lamps are less than 750mm above the ground)
Stop Lamps	Min 2 Max 2 (see Note 7)	Mandatory	Red	400	1500 or if impracticable 2100	350	a. Horizontal i. 45° inwards and outwards b. Vertical i. as rear position lamps.
Stop Lamps (Optional)	Min 1 Max 2 (see Note 7)	Optional	Red	If 1 is fitted: as close to vehicle centreline as practicable. If 2 are fitted: no requirement	n/a	no lower than the mandatory stop lamps	Must face the rear
End Outline Marker Lamp	2 visible from the front and 2 visible from the rear Optional Any (see Note 7)	Mandatory on vehicles exceeding 2.10m wide Optional on vehicles 1.80m to 2.10m in width	Front-White o– Amber Rear - Red	As close as possible to the extreme edge and not more than 400mm from the edge	See ³ below	Front: No lower than the upper edge of the windscreen Rear: as high as practical, bearing in mind the need to mount the lamps as close as possible to the extreme edge	a. Horizontal i. 80° Outwards b. Vertical i. 5° Above the horizontal ii. 20° Below the horizontal

End-outline, Position (Side), Stop, Side Marker & Daytime Running Lamps 22

TYPE	NUMBER	APPLICATION	COLOUR	POSITION			ANGLES OF VISIBILITY
				MAX DISTANCE FROM SIDE (mm)	MAX HEIGHT (mm)	MIN HEIGHT (mm)	
Side Marker Lamp	See below	Mandatory where the length exceeds 6m	Amber The rearmost marker may be red if within 1m of rear	See ² below	1500 or if impracticable 2300	250	a. Horizontal i. 45° to the front and rear (Can be reduced to 30° if fitted as an optional extra) b. Vertical i. 10° Above and below the horizontal (The vertical angle below the horizontal may be reduced to 5° if the side marker lamp is fitted less than 750mm from the ground)
Daytime Running Lamp (Optional)	Min 2 Max 2	Optional	White	400mm	1500mm	250mm	a. Horizontal i. 20° Outwards and inwards b. Vertical i. 10° Upwards and downwards

¹ Side Marker Spacing

- at least one side marker lamp must fitted to the middle third of the vehicle
- the foremost side marker lamp being not further than 3 m from the front
- the distance between two adjacent side marker lamp shall not exceed 3 m if the structure of the vehicle makes it impossible to comply with such a requirement, this distance may be increased to 4 m
- the distance between the rearmost side marker lamp and the rear of the vehicle shall not exceed 1 m

² Positional Requirement for Side Markers used to supplement the angles of visibility for Position lamps and Directional Indicators

These marker lamps must be fitted as near to the front / rear of the vehicle as possible and in no case beyond the midpoint of the front / rear wheel arch.

³ Symmetrical requirements for Position and End Outline Marker Lamps

In addition to the positional requirements in Table 1, the lamps specified when fitted as pairs should be positioned symmetrically where practicable and where structure exists, fitted one on each side of the vehicle at the same height above the ground, and at the same distance from the extreme outer edge of the vehicle.

End-outline, Position (Side), Stop, Side Marker & Daytime Running Lamps 22

Record of Revision

Revision	Date	Description of Change
1	18/04/2011	Version 1
2	31/05/2012	Add information to Note 6
3	11/03/2013	Amend permitted number of stop lamps in Table 1.
4	03/04/18	Clarify Stop Lamp requirements in Table 1.
5	01/04/2022	Note 7 referenced from RS 6, 11 and 22.
6	22/05/2023	Add information to Note 7.
7	09/10/2024	Note 3 revised. Add footnote to Table 1 relating to symmetrical requirements for Position and End Outline Marker Lamps (TSE N1 020 011).

End-outline, Position (Side), Stop, Side Marker & Daytime Running Lamps 22

23 Direction Indicators

Application: All Vehicles

Method of Inspection	Required Standard
<p>Carry out a visual check of all direction indicators including side repeater lamps fitted to the vehicle for operation, colour, number, and correct positioning. With optional lamps check that fitment is permitted, and they do not exceed the maximum number of lamps allowed to be fitted</p> <p>Note 1: A tell-tale is not required if the front indicators are directly clearly visible to the driver.</p> <p>Note 2: The positional and angles of visibility requirements are required to be met when all doors, bonnet, boot lid etc. are in the closed position only.</p> <p>Note 3: Side repeater indicators mounted on 'cycle wings' that move with steering movement are required to meet the angles of visibility with the steering in the straight-ahead position only.</p> <p>Note 4: Side marker lamps are permitted to flash, providing they are of the type SM1 or SM2 only, and the flashing is in phase with the direction indicator on the same side of the vehicle. On N1 vehicles less than 6 m in length, side-marker lamps may be used to supplement the angles of visibility requirements of front indicator lamps or rear indicator lamps where the obligatory lamps do not meet those requirements. Where applicable, these lamps must be fitted as near to the front / rear of the vehicle as possible, and in no case beyond the mid-point of the front / rear wheel arch (see Figure 1A Section 20).</p>	<p>Directional Indicators and side repeaters;</p> <ol style="list-style-type: none"> 1. They must be operational. 2. The correct number must be fitted to the vehicle (Table 1). 3. The indicators must flash at a rate of between 60 and 120 times a minute (with all mandatory indicators working, and with the engine running). 4. There must be an audible or visual tell-tale fitted to indicate the operation of any indicators such that would not cause confusion to the driver (see Note 1). 5. All indicators must emit amber light. 6. They must be positioned to meet <ol style="list-style-type: none"> a. the positional requirements of Table 1 (see Note 2). b. the angles of visibility requirements of Table 1 (see Notes 2 & 3). <p>Hazard Warning Lights;</p> <ol style="list-style-type: none"> 7. Must operate with the ignition switched on and off. 8. The hazard warning device must operate all of the direction indicators simultaneously. 9. The hazard warning device must have a tell-tale warning light (see Note 1).

Direction Indicators 23

Method of Inspection	Required Standard
<p>Note 5: Geometric angles of visibility and positional requirements are not required for all optional direction indicators.</p>	

Table 1

TYPE	NUMBER	APPLICATION	COLOUR	POSITION			ANGLES OF VISIBILITY
				MAX DISTANCE FROM SIDE (mm)	MAX HEIGHT (mm)	MIN HEIGHT (mm)	
Direction Indicators & Hazard Warning	Motor Vehicles On each side Front – One Rear – One Side Repeater – One (see Note 4 & Note 6) Plus 2 optional all vehicles- Rear only (see Note 5)	Mandatory	Amber	400 (Min separation 500 unless vehicle width is less than 1400, where Min separation 400) (see Note 7 below)	1500 or if impracticable 2300 for side direction indicators and 2100 for front and rear direction indicators	350	a. Horizontal i. 80° outwards 45° inwards. ii. < 750mm above the ground 20° inwards iii. (SIDE REPEATER) To the rear between 5° and 60° outboard. b. Vertical i. < 750mm above the ground 15° above and 5° below horizontal. ii. Otherwise 15° above and below horizontal.

Note 6: A side repeater lamp must be fitted within 2600 mm of the front of the vehicle.

Note 7: Position/Max distance from side (mm): 400 or in the case of a front indicator on a left-hand drive mass produced vehicle - 510 where flashing front side marker lamps are fitted, or in the case of a rear indicator on a left-hand drive mass produced vehicle, 480 where it is one of a number of lamps having a common lamp housing.

Record of Revision

Revision	Date	Description of Change
1	18/04/2011	Version 1
2	31/05/2012	Insert new Note 3 angles of visibility for side repeater lamps mounted on 'cycle wings' & new item (ii.) in table 1 Horizontal angles of visibility
3	05/10/2015	Correct Note numbering
4	22/05/2023	Revise Note 4 to include reference to flashing Side Marker lamps (TSE IVA N1 022 004).
5	09/10/2024	Note 4 revised & added reference to Note 4 from Table 1.

24 Rear Registration Lamps

Application: All Vehicles

Method of Inspection	Required Standard
<p>Carry out a visual check of all rear registration plate lamps fitted to the vehicle for operation, colour, and correct positioning. With optional lamps check that fitment is permitted, and they do not exceed the maximum number of lamps allowed to be fitted</p> <p>Note 1: See Section 4 Rear Registration Plate Space in conjunction with position of rear registration plate lamp</p>	<p>Rear registration plate lamps</p> <ol style="list-style-type: none">1. They must be operational2. They must be able to be switched on and off with the front and rear position lights by operating one switch3. They must only emit white light4. They must be positioned sufficient to illuminate the rear registration plate (see Note 1).

Record of Revision

Revision	Date	Description of Change
1	18/04/2011	Version 1
2	01/09/2020	RS4 linked to Note 1.

25 Headlamps

Application: All Vehicles

Method of Inspection	Required Standard
<p>Carry out a visual check of all headlamps fitted to the vehicle for operation, colour, number, and correct positioning.</p> <p>With optional lamps check that fitment is permitted, and they do not exceed the maximum number of lamps allowed to be fitted</p> <p>Note 1: The “Main Beam” tell-tale can be either blue in colour, or a tell-tale– (any colour - preferably blue) with the symbol (see section 33) or a tell-tale any colour and the words Main Beam or Main</p> <p>Note 2: Required Standard 10 a) & b) does not apply to unmodified, mass-produced vehicles fitted with LED Headlamps, or mass-produced vehicles fitted with LED Headlamps that have been subsequently converted or modified, providing that the vehicle is unmodified forward of the A-pillar.</p> <p>Note 3: In the case of a left-hand drive vehicle where the headlamp height above the ground does not exceed 850mm, the requirement for headlamp cleaning shall not apply.</p> <p>Note 4: Where vehicles are fitted with Gas Discharge (HID) or LED Headlamps, the requirement for automatic headlamp self-levelling system or self-levelling suspension shall be deemed to be complied with where evidence (manufacturer or Technical Service) is provided that the vehicle meets the requirements of 6.2.6.1.2 of UNECE</p>	<p>Headlamps;</p> <ol style="list-style-type: none"> 1. All obligatory and optional headlamps must be fitted as “matched pairs”. 2. They must be operational. 3. They must be fitted in the correct orientation as would be on an approved vehicle. 4. They must emit a white light. 5. When on dip or main beam they must emit sufficient light to be able to illuminate the road in front of the vehicle. 6. The correct number must be fitted to the vehicle (Table 1). 7. Dipped beam headlamps must be positioned to meet the requirements of Table 1. 8. There must be a tell-tale when on Main Beam (see Note 1). 9. Where the dipped beam is provided by gas discharge (HID) light sources these must remain lit when the headlamp is switched to main beam. <p>Headlamp Cleaning Systems and Levelling Devices (see Note 2)</p> <ol style="list-style-type: none"> 10. Vehicles fitted with Gas Discharge (HID), or LED headlamps producing the principal dipped beam must: <ol style="list-style-type: none"> a) be accompanied with evidence that the light output does not exceed 2000 lumens (see Note 5), or

Method of Inspection	Required Standard
<p>Regulation 48.03 in all loading conditions as defined in Annex 5 to Reg 48.03</p> <p>Note 5: Where vehicles are fitted with Gas Discharge (HID) or LED Headlamps the luminous flux (measured in lumens) will need to be confirmed with evidence (manufacturer or Technical Service) relating to the relevant UNECE regulation. Regulation 99 for gas discharge light sources, Regulation 112 (para 5 to Annex 10) for LED modules, Regulation 123 for vehicles fitted with Adaptive Front-lighting Systems (AFS), and Regulation 149 covering road illumination devices (lamps) and systems. Evidence of compliance must be either VIN specific or reference the particular lamp assembly/light source e.g., by a permanent manufacturer's approval number, type, or part number.</p> <p>Headlamp Aim</p> <p>Align the headlamp aim testing equipment to the vehicle in accordance with the manufacturer's instructions (In instances where it is not possible to conform to this guidance due to characteristics of the vehicle under test, examiners should position the headlamp tester as close as practicable to the headlamp under test). Check the alignment of each dipped beam headlamp in association with the appropriate criteria.</p> <p>Headlamps producing a flat dip beam are acceptable and will not have to meet the aim criteria for "break point".</p> <p>Note 6: The alignment requirement must be met without the use of masks or beam converters unless they are an integral part of the headlamp as it was approved. Devices or materials applied to the inside of a headlamp which were not present at the time of approval are unacceptable.</p> <p>Some vehicles may be fitted with an in-car driver's headlamp adjustment device. This may be adjusted to</p>	<p>b) be accompanied with evidence of self-levelling (see Note 4) and be fitted with a headlamp cleaning system (see Note 3).</p> <p>Headlamp Aim (see Note 6)</p> <p>European Type (checked on dipped beam)</p> <p>11. The beam image 'kick-up' must not be to the offside.</p> <p>12. For headlamps with centres not more than 850mm from the ground, the beam image horizontal cut-off must be between the horizontal 0.5% and 2% lines, i.e., the red tolerance band.</p> <p>13. For headlamps with centres more than 850mm from the ground, the beam image horizontal cutoff must be between the horizontal 1.25% and 2.75% lines, i.e., the blue tolerance band.</p> <p>14. The beam image 'break point' must not be to the right of the 0% vertical line, or to the left of the vertical 2% line.</p> <p>British American (checked on main beam)</p> <p>15. The 'hot spot' centre must not be above the horizontal 0% line.</p> <p>16. The 'hot spot' centre must not be to the right of the vertical 0% line, or the left of the vertical 2% line.</p> <p>17. For headlamps where the centre is not more than 850mm from the ground, the 'hot spot' centre must not be below the horizontal 2% line.</p> <p>18. For headlamps where the centre is more than 850mm from the ground, the 'hot spot' centre must not be below the horizontal 2.75% line.</p> <p>19. When switched from Main beam to dipped beam the image must "Dip" to the left.</p>

Method of Inspection	Required Standard
<p>enable both headlamps to meet the criteria. Both headlamps, however, must comply with the requirements with the device set in one position.</p> <p>Note 7: American headlamps that dip to the right are deemed to have met this requirement as long as all of the upper edge of the beam pattern is between the dip beam parameters.</p>	<p>British American (checked on dipped beam) (see Note 7)</p> <ul style="list-style-type: none">20. The upper edge of the 'hot spot' must not be above the horizontal 0% line.21. The upper edge of the 'hot spot' must not be below the horizontal 2.75% line.22. The right-hand edge of the 'hot spot' must not be to the right of the vertical 0% line, or to the left of the vertical 2% line.

European Type Headlamp

Checked on Dipped Beam

Check the position of the 'break point' and horizontal cut-off.

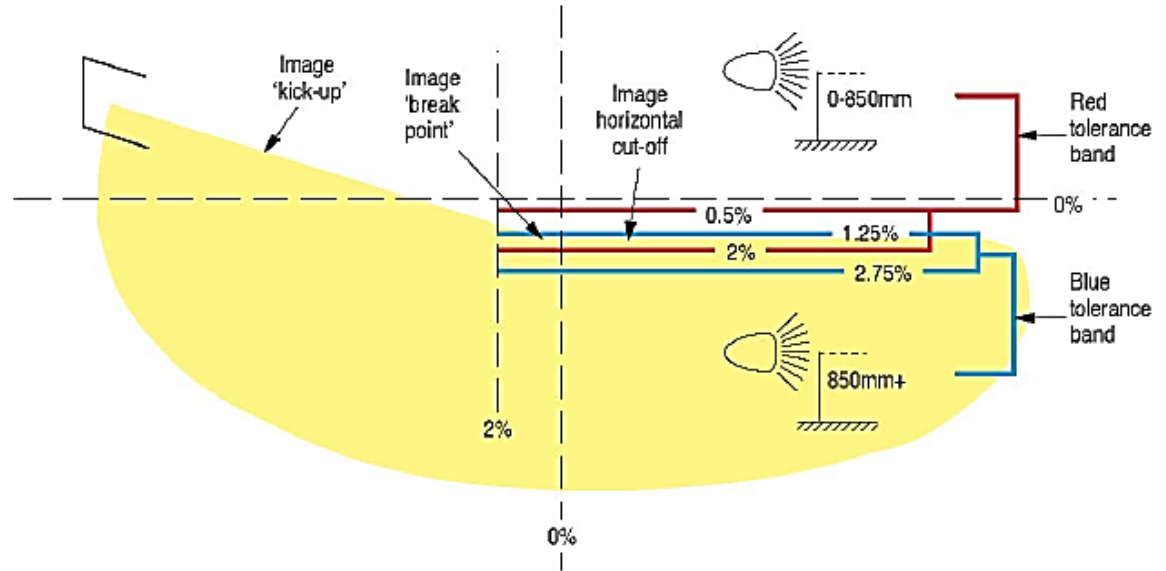

British American Headlamp

Checked on Main Beam

Check the position of the centre of the area of maximum intensity ('hot spot').

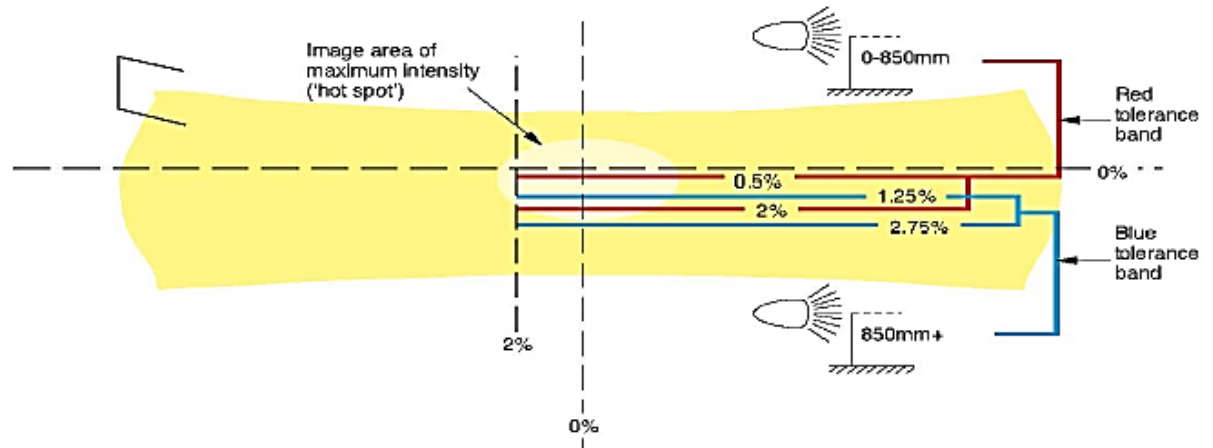

British American Headlamp

Checked on Dipped Beam

Check the position of the upper and right-hand edge of the area of maximum intensity ('hot spot').

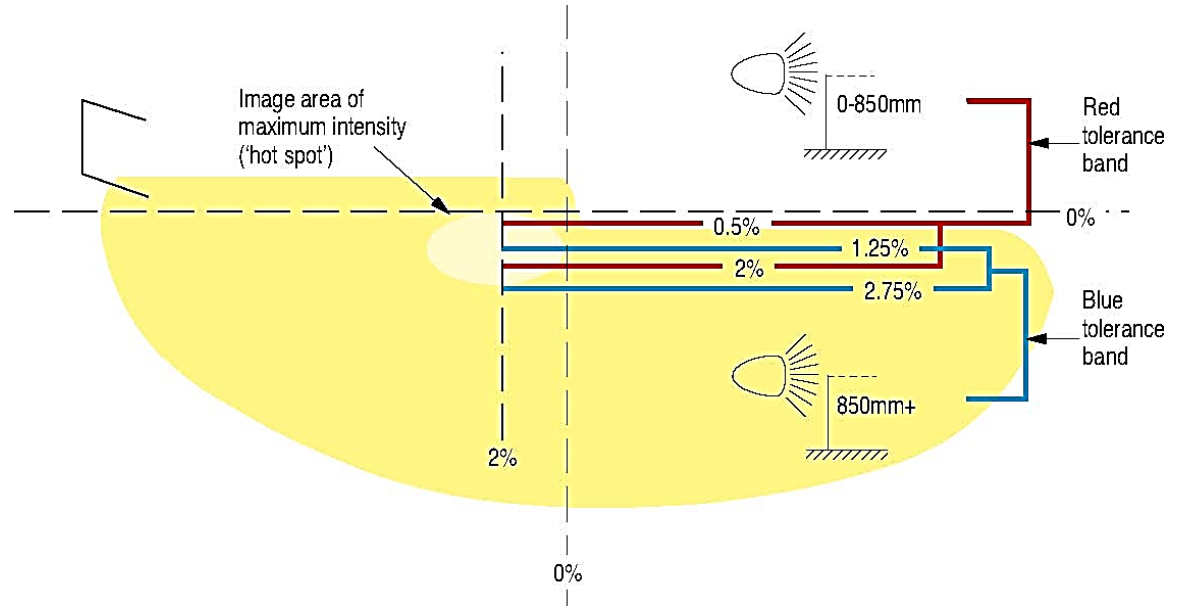

Table 1

TYPE	NUMBER	APPLICATION	COLOUR	POSITION			ANGLES OF VISIBILITY
				MAX DISTANCE FROM SIDE (mm)	MAX HEIGHT (mm)	MIN HEIGHT (mm)	
Dipped Beam Headlamp	Min 2 Max 2	Mandatory	White	400	1200	500	45° out 10° in 15° up 10° down
Main Beam Headlamp	Min 2 Max 4	Mandatory	White	-	-	-	NO REQUIREMENT

Annex 1 Headlamp Light Sources

Tungsten Halogen

An improvement over normal tungsten filament lamps (as used in other vehicle lighting), the bulb envelope is filled with halogen gas. A tungsten-halogen lamp has a much longer brightness lifetime than similar filaments operating without the halogen regeneration cycle.

The most common type of light source for headlamps. Come in a variety of styles, the most common being H1, H3, H4 and H7.

The 'H' in the diagram below indicates a halogen light source.



UN Definition: 'Filament light source' means a light source where the only element for visible radiation is one or more filaments producing thermal radiation;

High Intensity Discharge (HID)

High-intensity discharge lamps (HID) produce light with an electric arc rather than a glowing filament. Automotive HID may be called '**xenon headlamps**', though they are actually metal-halide lamps that contain xenon gas. The xenon gas allows the lamps to produce minimally adequate light immediately upon start and shortens the run-up time. They may also be call **gas discharge** headlamps because the light sources are formally known as gas-discharge burners.

These light sources require an ignitor to initiate the light and a ballast resistor to control current.

The diagram below gives an example of a gas discharge light source approval marking. Note the usual circle around the country identifier is truncated.

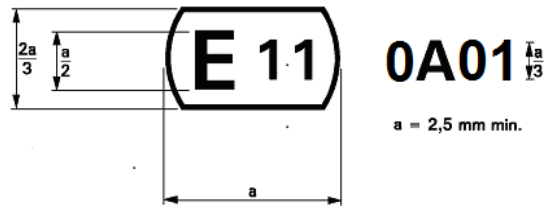

The approval mark examples below show a gas discharge (Class E) passing beam headlamp (WC-ES) on the left and a passing and driving beam headlamp (WCR-ES) on the right

WC-ES PL



01 2493

WCR-ES PL



01 2493

UN definition: 'Gas-discharge light source' means a light source where the only element for visible radiation is a discharge arc producing electroluminescence;

Light Emitting Diode (LED)

A light-emitting diode (LED) is a semiconductor light source that emits light when current flows through it.

While LED lamps have been in use for position, stop, direction indicator and rear registration plate lamps for some time their use in headlamps is relatively recent.

LED modules should be marked as below E'x' indicates the approving country

MD E3 17325

UN definition: "Light-emitting diode (LED) light source" means a light source where the only element for visible radiation is one or more solid-state junctions producing electroluminescence possibly completed with one or more elements for fluorescence-based conversion.

Record of Revision

Revision	Date	Description of Change
1	18/04/2011	Version 1
2	31/07/2011	Amend section relating to gas discharge headlamps to include new Note 4 and procedures in RS 8 if vehicle not compliant.
3	31/10/2011	Add information in Note 4 ref. aligning headlamp aim tester
4	31/05/2012	Insert reference to Note 5 in Headlamp Aim RS
5	01/09/2020	Insert new Annex 1 Headlamp Light Sources.
6	01/04/2022	New RS 9, 10 & 11, remaining RS renumbered. Notes 3 & 4 expanded.
7	22/05/2023	Add information to MOI, Remove RS10 & RS11, New RS10 and remaining RS renumbered. Revise Note 4 to include Regulation 123 & 149.
8	09/10/2024	New Note 2 referenced from RS10; subsequent notes renumbered. (TSE IVA N1 025 009)

This page intentionally left blank

26 Front Fog Lamps

Application: All Vehicles (Optional)

Method of Inspection	Required Standard
<p>Carry out a visual check of all front fog lamps fitted to the vehicle for operation, colour, number, and correct positioning</p> <p>Note 1: This may be achieved by an unlit pictogram (see section 33) or appropriate words, the tell-tale may be any colour provided it cannot be confused with any other tell-tale.</p> <p>Note 2: a tell-tale can be taken to include any marking of a switch or control which clearly defines its function.</p>	<p>Front fog lamps;</p> <ol style="list-style-type: none"> 1. The correct number must be fitted to the vehicle (Table 1). 2. They must be operational. 3. They must be able to be switched on only when the position lights are on and must operate independently of the dipped and main beam headlamps. 4. They must only emit white or yellow light. 5. Must be fitted with a tell-tale (see Note 2). 6. Either the switch or tell-tale must clearly indicate that operation relates to the front fog lights. (see Note 1). 7. They must be positioned correctly to meet the positional requirements of Table 1.

Table 1

TYPE	NUMBER	APPLICATION	COLOUR	POSITION			ANGLES OF VISIBILITY
				RECOMMENDED MAX DISTANCE FROM SIDE (mm)	MAX HEIGHT (mm)	MIN HEIGHT (mm)	
Front Fog Lamps	Two (Maximum)	Optional	White or Yellow	400	800 max., however No higher than the top edge of the dipped beam headlamp	250	

Front Fog Lamps 26

Record of Revision

Revision	Date	Description of Change
1	18/04/2011	Version 1
2	31/10/2011	Insert new Note 2 and amend wording for RS3

28 Rear Fog Lamps

Application: All Vehicles

Method of Inspection	Required Standard
<p>Carry out a visual check of the rear fog lamps fitted to the vehicle for operation, colour, number, and correct positioning. This includes optional lamps.</p> <p>With optional lamps check that fitment is permitted, and they do not exceed the maximum number of lamps allowed to be fitted.</p> <p>Note 1: This may be achieved by an unlit pictogram (see section 33) or appropriate words, the tell-tale may be any colour provided it cannot be confused with any other tell-tale.</p> <p>Note 2: This does not apply to mass produced North American Vehicles approved with either FMVSS or CMVSS:</p> <ul style="list-style-type: none"> • when the fog lamp has been produced by conversion of a brake lamp, <p>or</p> <ul style="list-style-type: none"> • evidence that the lamp gives suitable intensity has been provided. <p>or</p> <ul style="list-style-type: none"> • In the case of North American produced vehicles, the lamp gives equal intensity to the stop lamps. 	<p>Rear fog lamps;</p> <ol style="list-style-type: none"> 1. They must be operational. 2. The correct number must be fitted to the vehicle (Table 1). 3. They must only emit a red light. 4. The rear fog lamp(s) must only illuminate when dipped beam, main beam or front fog lamps are lit (see alternatives in Notes 3 & 4). 5. They must be positioned correctly to meet: <ol style="list-style-type: none"> a. the positional requirements of Table 1 b. the angles of visibility requirements of Table 1 6. Must be fitted with an operational “tell-tale” lamp (non-flashing) visible from the driving position. 7. Either the switch or tell-tale must clearly indicate that operation relates to the Rear Fog lights. (see Note 1). 8. Must not be operated by a brake control. 9. Fitted so that the reflector is facing squarely to the rear. 10. An optional rear fog lamp must form a matched pair with the obligatory lamp.

Rear Fog Lamps 28

Method of Inspection	Required Standard
<p>Note 3: Front fog lamps may be illuminated with the front position (side) lamps only.</p> <p>Note 4: Either of the following scenarios will also be considered acceptable:</p> <ul style="list-style-type: none"> The rear fog lamp(s) may continue to operate until the position lamps are switched off, and the rear fog lamp(s) must then remain off until deliberately switched on again or, A warning, at least audible, additional to the mandatory tell-tale light shall be given if the ignition is switched off or the ignition key is withdrawn and the driver's door is opened, whether the lamps in (RS4) are on or off, whilst the rear fog lamp switch is in the "on" position. 	<p>11. An optional rear fog lamp must only operate with the obligatory rear fog lamp.</p> <p>12. All rear fog lamps must display an 'e' or 'E' mark with a 'B' or 'F' (see Note 2).</p>

Table 1

TYPE	NUMBER	APPLICATION	COLOUR	POSITION			ANGLES OF VISIBILITY
				MAX DISTANCE FROM SIDE (mm)	MAX HEIGHT (mm)	MIN HEIGHT (mm)	
Rear Fog Lamp	Min 1 Max 2	Mandatory	Red	At least one must be on centre line or to offside of vehicle (Min separation distance from stop lamp 100)	1000 When grouped with any rear lamp this may be increased to 1200	250	a. Horizontal i. 25° inwards and outwards; if two lamps are fitted it is sufficient if one lamp (not necessarily the same lamp) – is visible throughout the range b. Vertical i. 5° above and below horizontal.

Record of Revision

Revision	Date	Description of Change
1	18/04/2011	Version 1
2	31/07/2011	Add bullet point to Note 2
3	31/10/2011	Remove tables 2 & 3, add new Note 3, and amend RS4
4	05/10/2015	Insert new note 3 and link to RS4, amend Max Height in Table 1
5	03/04/2018	Inset new Note 3 & renumber following note. Update link from RS4.

This page intentionally left blank

29 Reversing Lamps

Application: All Vehicles

Method of Inspection	Required Standard
Carry out a visual check of the reverse lamps fitted to the vehicle for operation, colour, number, and correct positioning.	<p>Reverse lamps;</p> <ol style="list-style-type: none"> 1. They must be operational. 2. The correct number must be fitted to the vehicle. (Table 1) 3. They must emit white light and be positioned as per Table 1. 4. They must be positioned to face the rear. 5. They must operate by selection of reverse gear. 6. Where two lamps are fitted they must be fitted symmetrically and be a matched pair.

Table 1

TYPE	NUMBER	APPLICATION	COLOUR	POSITION			ANGLES OF VISIBILITY
				MAX DISTANCE FROM SIDE (mm)	MAX HEIGHT (mm)	MIN HEIGHT (mm)	
Reversing Lamps	Min 1 Max 2	All Vehicles up to 6000mm	White	No requirement	1200	250	To the rear
	Min 2 Max 4 (Includes optional lamps)	Vehicles with a length exceeding 6000mm					

Reversing Lamps 29

Record of Revision

Revision	Date	Description of Change
1	18/04/2011	Version 1
2	05/10/2015	Amend no. of lamps in Table 1.
3	03/04/2018	Update RS3.
4	09/10/2024	Revise RS5 (TSE IVA N1 29 002).

30 Parking Lamps

Application: All Vehicles (Optional)

Method of Inspection	Required Standard
<p>Carry out a visual check of all parking lamps fitted to the vehicle for operation, colour, number, and correct positioning. With optional lamps you must check that their fitment is permitted, and they are not exceeding the maximum number of lamps allowed to be fitted</p> <p>The functioning of parking lamps may also be performed by simultaneously switching on the front and rear position lamps on one or the other side of the vehicle.</p> <p>Note 1: An operational parking lamp system is to be considered acceptable if the presented vehicle is over 6 metres long only when it has been built in more than one stage and the parking lamp system was approved at the base vehicle stage.</p> <p>Note 2: The parking lamp(s) and, if applicable, the front and rear position lamps, must be able to operate even if the device which starts the engine is in a position which makes it impossible for the engine to operate.</p> <p>Note 3: The parking lamp(s) on the same side of the vehicle may be lit independently of any other lamps. For example, when a vehicle is parked on the left hand side of the road the right hand front and rear position lamps, or the dedicated right hand parking lamp(s) may be illuminated and vice versa at the discretion of the driver.</p>	<p>Parking lamps;</p> <ol style="list-style-type: none"> 1. They are not permitted on vehicles that exceed 6 metres in length, or 2 metres in width (see Note 1). 2. They must be operational (see Notes 2 & 3). 3. The correct number must be fitted to the vehicle (Table 1). 4. They must only emit red light to the rear / white light to the front. 5. They must be positioned to meet <ol style="list-style-type: none"> a. the positional requirements of Table 1. b. the angles of visibility requirements of Table 1. 6. The switch must allow the parking lamp(s) on the same side of the vehicle to be lit independently of any other lamps. 7. A device which automatically deactivates these lamps as a function of time is prohibited. 8. A closed circuit tell-tail for the parking lamps is optional. However, if a tell tail is fitted it must not be possible to confuse it with the tell-tale for the front and rear position lamps.

Table 1

TYPE	NUMBER	APPLICATION	COLOUR	POSITION			ANGLES OF VISIBILITY
				MAX DISTANCE FROM SIDE (mm)	MAX HEIGHT (mm)	MIN HEIGHT (mm)	
Parking Lamps	Either 2 front and 2 rear Or 1 lamp on each side	Optional on Motor Vehicles not exceeding 6m in length and 2m in width Prohibited on other vehicles	Front— White Rear - Red	400mm from the edge			a. Horizontal i. 45° Outwards, forwards, and rearwards b. Vertical i. 15° Above and below the horizontal (The vertical angle below the horizontal may be reduced to 5° if the lamp height is less than 750mm)

Record of Revision

Revision	Date	Description of Change
1	18/04/2011	Version 1
2	05/10/2015	Insert new Notes 1 & 3, and insert number at paragraph 3, amend second para of MOI

This page intentionally left blank

31 Seat Belts

Application: All Vehicles

Method of Inspection	Required Standard
<p>The requirements in column 2 do not apply to seats intended for use solely while the vehicle is stationary or for when the vehicle is not used on a public road.</p> <p>Any seats which are not for use when travelling on a public road must be clearly identified to users by means of a pictogram or a sign with appropriate text.</p> <p>In the case of armoured vehicles exemption from any requirement of this section is permitted if it can be demonstrated to the satisfaction of the Approval Authority that it is impossible for the vehicle to comply due to its special purpose.</p> <p>Check that whilst sitting in each seat in turn, and wearing the seat belt, secured and correctly adjusted, that the position of the webbing on the torso and the location of the effective belt anchorage points in relation to the seated body position are correct. In the case of a standard mass-produced vehicle there will be no need to sit in each seat and assess the fit of the belt on the torso.</p> <div style="display: flex; align-items: center; margin-top: 20px;">  <div style="margin-left: 10px;"> <p>Figure 1</p> <p>It is considered acceptable for an airbag label to be displayed on only one side of a sun visor</p> </div> </div>	<ol style="list-style-type: none"> 1. Each seat requiring a belt must be fitted with a seat belt of the appropriate type. (see Annex 1). 2. Each seat belt must bear the appropriate approval marks or have the equivalent characteristics to that of a belt approved for the same category of vehicle to ensure the belt meets the required approval standards (see Note 4). 3. Each seat belt must be attached by an appropriate fixing and be securely fitted (see Notes 2 & 3). 4. There must be no damage to the seat belt structure that would affect its strength. 5. The lock mechanism must securely lock the belt. 6. The lock mechanism must be able to be released easily, both in normal use and when the belt is under load. 7. With the seat belt fastened and the seat unoccupied, retractor mechanisms must take up any excess webbing (see Note 5). 8. A retractor mechanism must be correctly positioned to ensure the correct operation of the belt (see Notes 6 & 7). 9. The seat belt must sit correctly across the wearer's torso so as to provide effective restraint in the event of a frontal impact (see Notes 8, 9, 10 & 11).

Method of Inspection	Required Standard
	<p>10. There must not be any sharp edges / objects in the seat belt area likely to cause damage to the belt.</p> <p>11. The seat belt must be able to be stored so it is always readily accessible to use (see Note 12).</p> <p>12. Where an airbag is fitted in front of a passenger position, a warning label for the airbag must be permanently fixed to the vehicle.</p> <p>13. The warning label for the airbag must be visible in front of a person about to install a rearward facing child restraint (Figure 1).</p> <p>14. The warning label for the airbag must be visible when the door is closed otherwise a permanent reference elsewhere that is visible at all times is required.</p> <p>15. A harness or three-point belt “effective upper anchorage” location must be at least 450mm above the reference point. (see Note 13).</p> <p>16. A lap/diagonal belt “effective upper anchorage” location must be at least 140mm from the longitudinal centre line of the seat. (see Note 13).</p> <p>17. The lower anchorages must be at least 350mm apart.</p> <p>18. The lower anchorages on side ward facing seats must be at least 350mm apart but no further apart than 500mm.</p>

Figure 2

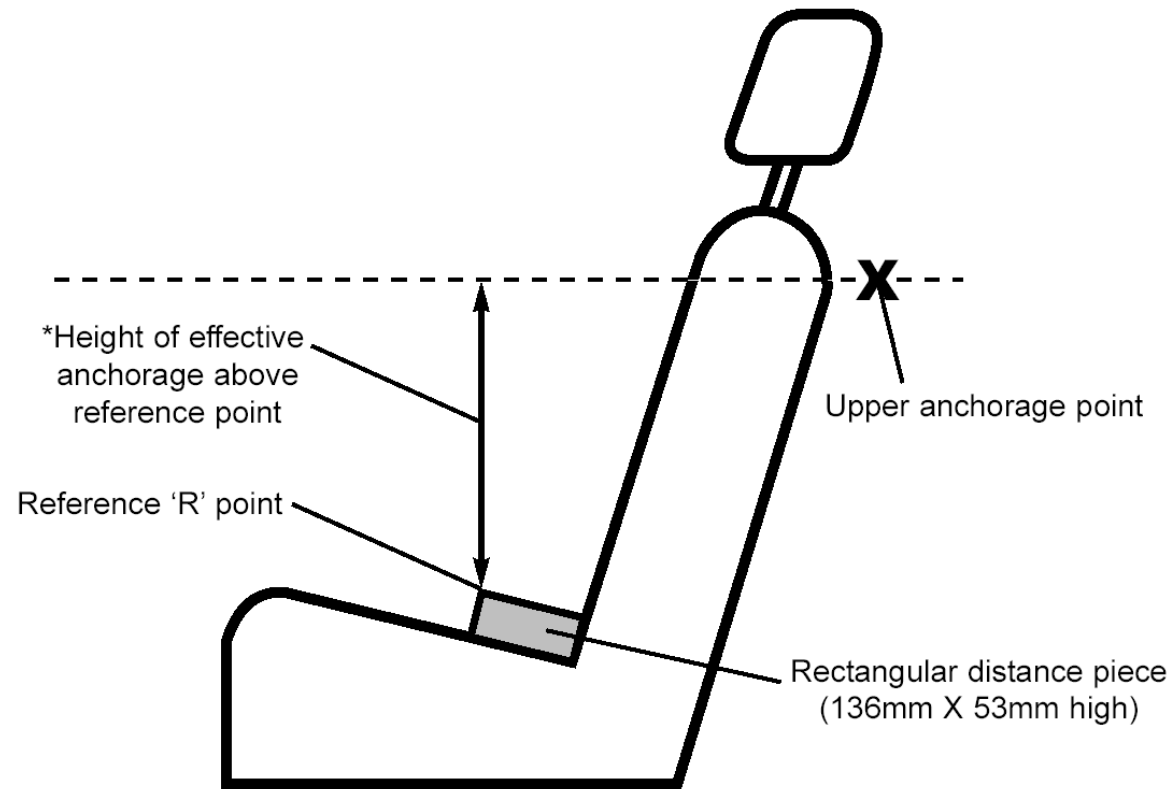

Note 1: A British Standard BS3254 Part 1 1988 or evidence of FIA 8853-98 approval for a harness belt is acceptable.

Note 2: A suitable single bolt fixing of adequate strength would be, for example, a bolt of at least 11mm (7/16") diameter of grade 8.8 (the grade may not be shown on a bolt produced for a seat belt anchorage). Other bolt fixings may be acceptable providing they are of equivalent strength. Two adjacent seat belts may be secured by one bolt. In this case consideration must be given to the additional loads on the anchorage.

Note 3: In order that a seat belt can be separated from the anchorage without causing damage to the anchorage, for example a mounting in the side of a tube or box section, it is a requirement that the bolt is secured into a "fixed" threaded hole or captive nut. (The presenter may be required to demonstrate this condition is met). The bolt may be secured into an alternative fixing, e.g., a lock nut of suitable strength, where access is provided to the "rear" of the mounting to enable separation/re-attachment of the belt.

Note 4: Characteristics include

The webbing is of an equivalent type of material and where it is likely to come into contact with the body of the wearer is at least 46mm (33mm in the case of harness belt shoulder straps) in width.

All components are suitably protected against corrosion, e.g., plated or coated.

The locking mechanism, i.e., the buckle, when both under load and not under load, can be released by a single movement in one direction by either hand.

Other than a harness belt the locking mechanism contact area with the body of the wearer is not less than 46mm in width.

For a static seat belt there is a manual adjusting device

- accessible to the wearer when seated
- convenient and easy to use
- capable of being tightened with one hand.

For a retracting belt, the retractor locks when the vehicle is subject to deceleration, tilt or the belt is pulled quickly from the retracting mechanism

Note 5: Some types of retracting belt might need help before they retract and harness belts due to their design will not retract however excess webbing must be secured.

Note 6: A belt may be fitted with retractor mechanisms on both lap and diagonal sections. If fitted with a single retractor mechanism it must act initially on the diagonal (shoulder) section.

Note 7: An “automatically locking” retractor (i.e. one that allows extension of the belt to the desired length and when the buckle is fastened locks on retraction but then prevents subsequent forward movement by the wearer, unlike a typical inertia reel belt), is not permitted unless the feature is only provided after **full extension** of the belt from the retractor, i.e. for use as a child restraint.

Note 8: The seat belt must be capable of effectively restraining the occupant

- by the position of the lap belt (due to anchorage location) passing over the pelvic region
- in the case of a harness belt or three-point belt, by being positioned across the shoulder so that it does not slip off the shoulder of the occupant.

Note 9: Where the seat is adjustable, this check must be carried out with the seat secured in the rearmost position and with the back rest in the normal driving position, in any case at a rearward angle of not more than approximately 25° from the vertical.

Note 10: The **effective belt anchorage** is the actual anchorage point to the vehicle unless a change of direction of the belt to the wearer is produced by a fixed intermediate device, for example, a belt guide fitted to the upper part of a seat back.

Note 11: Where a seat incorporates a belt guide that creates the “effective belt anchorage” consideration must be given to the strength of the seat back in relation to the loading to which it may be subject, (this being dependent on the position of the actual anchorage). The requirements Section 19 RS 3 should be applied to the effective anchorage location

Note 12: An independent belt storage facility is only necessary where it is needed to ensure the belt is always accessible for use.

Note 13: The “effective anchorage” is any point where the load from a belt would be applied; consideration should be made to the suitability of the seat to withstand the loads likely to be imposed (**see Section 19**).

Annex 1 Seat Belts – Minimum Obligatory Requirements

NOTE: “EFFECTIVE DATE”

In the case of a mass-produced vehicle: The date of manufacture of the vehicle (evidence may be required).

In any other case: The date of the examination

Vehicle category - effective date	Front facing				Side facing Seat
	Outboard Seat		Centre Seat	Rear Seat	
	Front	Other	Front		
Light Goods Vehicles From 1999	3 Point retractor belt	3 Point retractor belt (see note 2 below)	2 Point lap belt (see note 1 below)	No requirement if protected seat, otherwise lap belt (see Section 19)	2 Point lap belt

TABLE NOTE 1: The front centre seat will require 3 anchorages where it is the driver’s seat, or the windscreen is located

- in the case of a fixed (non-sliding) seat, within 840mm. of the seat reference point
- in the case of a sliding seat, within 840mm. of the seat reference point when the seat is 127mm forward of its rearmost position.

TABLE NOTE 2: Outboard seats require a 3-point anchorage unless there exists a passage between a seat and the nearest sidewall of the vehicle intended to permit access of passengers to other parts of the vehicle. A space between a seat and the wall is considered as a passage, if the distance between that sidewall, with all doors closed, and a vertical longitudinal plane passing through the centerline of the seat concerned – measured at the R-point position and perpendicular to the median longitudinal plane of the vehicle – is more than 500mm.

TABLE NOTE 3: ‘3 point belt’ means a seat belt which,

- restrains the upper and lower parts of the torso
- includes a lap belt and a retractor that operates on the diagonal part
- is anchored at not less than three points, and
- is designed for use by an adult.

TABLE NOTE 4: The table lists the minimum required belt type. A 3-point retractor belt may be fitted where the minimum required is a 2-point lap belt and an acceptable alternative to any of the seat belt types listed is an adult harness belt comprising a lap belt and shoulder straps providing the anchorages satisfy section 19

TABLE NOTE 5: Outboard seats are seats closest to the vehicle sides.

Record of Revision

Revision	Date	Description of Change
1	18/04/2011	Version 1
2	05/10/2015	Insert text in Fig. 1, remove note 2 and renumber remainder.

This page intentionally left blank

32 Forward Vision

Application: All Vehicles

Method of Inspection	Required Standard
<p>Check that when seated in the driving position, the driver has a full un-obscured view of the road to the front and forward of the near side and offside of the vehicle (90° each side of straight ahead). The lower edge of the forward field of view must not be above the “windscreen horizontal plane” as defined in Annex 1 of this section</p> <p>In the case of unmodified Mass Produced vehicles, the standards in this section shall be considered to be met.</p> <p>Where evidence suggests that the vehicle has been modified, the examiner shall assess whether the modification would be likely to materially affect the performance of the relevant component or system, and if so, carry out assessment against the RS</p> <p>Note 1: The following items do not constitute an obstruction to the field of Vision. This is not an exhaustive list but provided as guidance:</p> <ul style="list-style-type: none"> • “A” pillars and split screen dividers • fixed or movable vent or side window division bars • outside radio aerials • rear view mirrors • windscreen wipers • “radio aerial” conductors not exceeding the following width; <ul style="list-style-type: none"> ○ embedded conductors – 0.5mm. ○ printed conductors – 1.0mm • defrosting and demisting conductors not exceeding 0.03mm visible width • steering wheel rim / instrument panel within wheel rim where highest part of rim is at least 1° below the horizontal (obtained as in Annex 1 of this section by substitution of 1° in place of 4°). 	<ol style="list-style-type: none"> 1. The driver must have a clear and un-obscured view of the road ahead and to 90° each side of straight ahead (see Note 1).

Annex 1

The “horizontal plane” is obtained by Measuring / projecting a line through a series of datum points from the driving position to its point of intersection with the windscreen or to the road ahead. The driver’s seat, if adjustable, should be adjusted to its rearmost / lowest position.

- a. In the case of a seat with an adjustable back rest, the measurements should be made with the seat back rest adjusted to an angle of 25°, line ‘A’ being parallel to the centre line of the seat back rest.
- b. In the case of a seat with a fixed back rest, the dimensions ‘A’ and ‘B’ should be as follows. A=562.5mm

The “horizontal plane” is at the point where the projection of line ‘C’ intersects the windscreen / windshield, or if above the windscreen / windshield, the vertically projected plane of the windscreen / windshield (line ‘D’).

Where the “horizontal plane” intersects Glazing at any point the Glazing is determined to be a windscreen. The vehicle will therefore be required to meet the standards of section 34 defrost/demist and section 35 wash/wipe.

Angle	‘A’	‘B’
15° - 19°	582.5mm	178.8mm
20° - 24°	572.0mm	182.6mm
25° - 29°	562.5mm	187.2mm
30° - 34°	553.4mm	191.3mm
35° - 39°	543.5mm	194.9mm
40° +	534.1mm	198.8mm

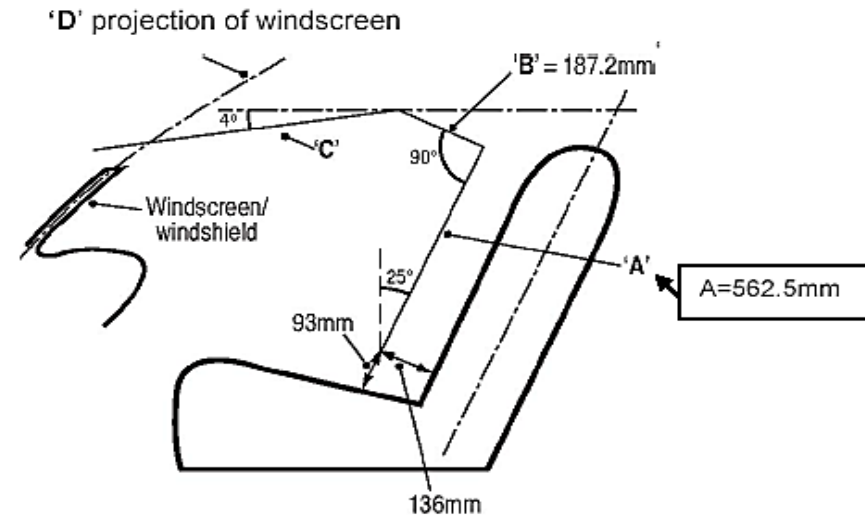

Record of Revision

Revision	Date	Description of Change
1	18/04/2011	Version 1
2	03/04/2018	Link RS1 to Note 1

This page intentionally left blank























33 Identification of Controls

Application: All Vehicles

Method of Inspection	Required Standard
<p>This inspection is to ensure that any controls, Tell-tales, and indicators fitted to the vehicle are; where required readily identifiable and in any case where displayed they would not cause confusion to the driver.</p> <p>Identification of certain controls, tell tales and indicators is mandatory and is covered in other relevant sections. This section only applies to optional identification where provided.</p> <p>Where a control, tell-tale or indicator is combined, a common symbol may be used for such a combination.</p> <p>Note 1: A control means that part of a device which enables the driver to bring about a change in the state or functioning of the vehicle. An indicator means a device which presents information on the functioning or situation of a system or part of a system. e.g., fluid level. A tell-tale means an optical signal which indicates the actuation of a device, correct or defective functioning or condition, or failure to function.</p> <p>Note 2: An Information Display Device is a device capable of displaying more than one type of message or information. The requirements regarding colour do not apply to tell-tales and indicators appearing on the Information Display Device.</p> <p>Note 3: Tables A and B are for guidance only any method of identification or colours may be used providing this would cause no confusion to the driver.</p>	<p>Where provided Identification of Controls, Tell-tales, and Indicators (see Note 1);</p> <ol style="list-style-type: none"> 1. Must be clear so not to cause confusion. 2. Must be on or as close to the controls, tell-tales, and indicators as possible as not to cause confusion. 3. Must stand out clearly from the background. <p>An Information Display Device if Fitted (see Note 2);</p> <ol style="list-style-type: none"> 4. Must be able to display simultaneously the warning symbols for Brake, Main beam, and Direction Indicator where this function is not provided elsewhere. 5. Must provide the relevant information regarding tell-tales and indicators whenever the situation that causes them to operate arises. 6. Must repeat automatically in sequence or indicate in such a manner that it is visible to and identifiable to the driver when two or more messages are given.











Identification of Controls 33

Table A

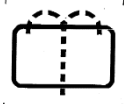
Control, Tell-tale or Indicator	Symbol	Colour of-light / tell - tale	Control, Tell-tale or Indicator	Symbol	Colour of-light / tell - tale	Control, Tell-tale or Indicator	Symbol	Colour of-light / tell - tale
Master Light		Green	Direction Indicators Or Hazard Warning if both flash together		Green	Ventilating fan		
Dipped Beam Headlamps		Green	Hazard Warning		Red	Diesel Pre-heat		Yellow
Main Beam Headlamps		Blue	Windscreen Wiper		Contrast with background	Choke (cold starting device)		Yellow
Position (side) Lamps		Green	Windscreen Washer		Contrast with background	Brake Failure		Red
Front Fog lamps		Green	Windscreen Wiper and Washer		Contrast with background	Fuel Level		Yellow
Rear Fog Lamps		Yellow	Headlamp Cleaning Device (with separate operating control)		Contrast with background	Battery Charging Condition		Red
Headlamp Levelling device			Windscreen demisting and defrosting (when separate)		Yellow	Engine Coolant temperature		Red
Parking Lamps		Green	Rear Window demisting and defrosting (when separate)		Yellow			

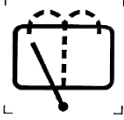
Identification of Controls 33

Table B

Control, Tell-tale or Indicator	Symbol	Notes	Colour of-light / tell - tale	Control, Tell-tale or Indicator	Symbol	Colour of-light / tell - tale
Parking Brake		Where a single tell-tale indicates more than one brake system condition, except brake anti-lock system failure, the symbol for brake failure must be used.		Horn		
Bonnet		Outline only may be used.		Rear Window Wiper		
Boot		Outline only may be used.		Rear window Washer.		
Seat Belt		Outline only may be used.	Red	Rear Window Wiper and washer.		
Engine Oil Pressure			Red	Intermittent Windscreen wiper.		
Unleaded Petrol						

Identification of Controls 33

Record of Revision

Revision	Date	Description of Change
1	18/04/2011	Version 1

34 Defrost / Demist

Application: All Vehicles fitted with a Windscreen (See section 32)

Method of Inspection	Required Standard
<p>Ensure that the vehicle is fitted with a system/systems capable of defrosting and demisting the windscreen to allow the driver an adequate view of the road in front and forward of the nearside and offside of the vehicle</p> <p>The fitting of a device not permanently incorporated into the vehicle structure i.e., adhered to the windscreen or body surface shall not be considered as a “system fitted to the vehicle”.</p>	<ol style="list-style-type: none"> 1. The vehicle must be fitted with a system capable of defrosting / demisting the windscreen. 2. A system using warm air to clear the screen must employ fan assistance and ducting to direct the air onto the screen, to ensure effective operation under cold weather conditions. 3. An electrically heated screen must provide adequate heat and distribution to ensure effective operation.

Record of Revision

Revision	Date	Description of Change
1	18/04/2011	Version 1
2	01/07/2018	Mass produced concession removed.

35 Wash Wipe

Application: All Vehicles fitted with a Windscreen (See section 32)

Method of Inspection	Required Standard
<p>Vehicles shall be fitted with adequate windscreen washing and wiping devices. Ensure that all wipers continue to move automatically over an area of the windscreen sufficient to give the driver an adequate view of the road in front and forward of the nearside and offside of the vehicle.</p> <p>In the case of unmodified Mass Produced vehicles, the standards in this section shall be considered to be met.</p> <p>Where evidence suggests that the vehicle has been modified, the examiner shall assess whether the modification would be likely to materially affect the performance of the relevant component or system, and if so, carry out assessment against the RS</p> <p>The engine should be running, and the windscreen must be kept wet when checking the wiper operating cycle frequencies.</p> <p>Note 1: This requirement does not apply where a wiper system is designed to operate an Intermittent or delay wipe frequency, but this must be in addition to those required by RS 3.</p> <p>Note 2: A “cycle” is the forward and return movement of the windscreen wiper.</p>	<ol style="list-style-type: none"> 1. The vehicle must be fitted with a windscreen washer and wiper system sufficient to give the driver an adequate view of the road. 2. All front wipers must continue to move automatically over the swept area of the windscreen (see Note 1). 3. All front wipers must have at least two sweep frequencies one of which must be of at least 45 cycles/min (see Note 2). 4. Additional Sweep frequencies must be of not less than 10 and not more than 55 cycles/minute (see Note 1). 5. The difference between the highest and at least one of the lower sweep frequencies must be at least 15 cycles/minute (see Note 2). 6. All front wipers must return automatically to a position of rest which is at or beyond the outer edge of the swept area, or to a vertical position in the centre of the windscreen. 7. All front wipers must be capable of being lifted from the windscreen to allow for cleaning of the windscreen. 8. The windscreen washer system must provide enough liquid to adequately clear the windscreen in conjunction with the wipers. 9. The windscreen washer system must have a reservoir capacity of at least 1 litre.

Wash Wipe 35

Method of Inspection	Required Standard
	10. The windscreen washer system must be able to withstand the load applied when the nozzles are blocked, and the system is operated for 3 – 5 seconds

Record of Revision

Revision	Date	Description of Change
1	18/04/2011	Version 1
2	22/05/2023	Revision of RS6 to allow wipers to rest at a vertical position in the centre of the windscreen.

This page intentionally left blank

36 Heating Systems

Application: All Vehicles (optional fitment)

Method of Inspection	Required Standard
<p>In the case of unmodified Mass Produced vehicles, the standards in this section shall be considered to be met.</p> <p>Where evidence suggests that the vehicle has been modified, the examiner shall assess whether the modification would be likely to materially affect the performance of the relevant component or system, and if so, carry out assessment against the RS</p> <p>Note 1: The air intake must not be positioned near the vehicles exhaust outlet or draw air from within an engine compartment etc.</p> <p>Combustion Heater</p> <p>Requires documentary evidence an 'E' or 'e' marked component and an installation check</p> <p>Ensure that any heater system is safe for use and is not dangerous</p> <p>Note 2: Example message. 'The heating system must not be used, and the gas cylinder valve must be closed when the vehicle is in motion'</p>	<p>Heating Systems</p> <ol style="list-style-type: none"> 1. must present no obvious fire risk (e.g., flammable parts of the vehicle near to a source of heat or a likelihood of users placing objects liable to catch fire on a very hot surface). 2. must present no obvious injury risk (e.g., likelihood of users touching a very hot surface or hot water pipes). 3. must have air intakes positioned so that there is no likelihood of polluted air being able to enter the passenger compartment, this does not include pollution from external sources (see Note 1). <p>Combustion Heater</p> <ol style="list-style-type: none"> 4. The vehicle must be accompanied by satisfactory evidence of compliance with the required standards for 'Heating Systems' <p>Installation Check</p> <ol style="list-style-type: none"> 5. A liquid fuelled or gaseous fuelled combustion heater must be fitted in accordance with the manufacturer's instructions. 6. There must be no obvious fire risk associated with the heating system. 7. It must be positioned so that it is not likely to cause injury.

Heating Systems 36

Method of Inspection	Required Standard
	<p>LPG heating systems for stationary use only.</p> <ul style="list-style-type: none">8. Permanent warning labels/pictograms instructing that the LPG heater shall not be in operation and that the valve of the portable LPG cylinder shall be closed when the vehicle is in motion shall be attached (see Note 2)<ul style="list-style-type: none">a. on the compartment where portable LPG cylinders are stored <p>and</p> <ul style="list-style-type: none">b. in close proximity to the control device for the heating system.

Record of Revision

Revision	Date	Description of Change
1	18/04/2011	Version 1
2	05/10/2015	Add combustion heater and LPG systems information.

This page intentionally left blank

45 Safety Glass

Application: All Vehicles

Method of Inspection	Required Standard
<p>Check that all windscreens, windows, and side screens are securely attached to the vehicle and are constructed from approved materials.</p> <p>Clear panels, not made of glass, fitted to the vehicle that do not impinge on the forward, rearward or sideward view of the driver are considered to be body panels and are not subject to the requirements of this section.</p> <p>Armoured vehicles do not have to display approval markings.</p> <p>Note 1: For definition of windscreen see section 32</p> <p>Note 2: “Safety Glazing” made from glass must be so constructed or treated that if fractured it does not fly into fragments likely to cause severe cuts. Each piece of glass must display the following relevant permanent marking applied by the glass manufacturer.</p> <p>UNECE Regulation 43  43R</p> <p>Note 3: “Safety Glazing” made from plastic means material which is so constructed or treated that if fractured it does not fly into fragments likely to cause severe cuts. “Safety glazing” made from plastic must have an “e” mark applied by the material manufacturer.</p> <p>Note 4: A greater opacity is permitted in the area of the windscreen below the “windscreen horizontal plane” and the area considered to be above the normal field of view.</p>	<ol style="list-style-type: none"> 1. Windscreens, windows, and side-screens where fitted must be securely attached to the vehicle. 2. Windscreens, windows, internal glazed panels, and side-screens where fitted must be suitable for its use (see Note 1 and Table 1). 3. Windscreens must be “Safety Glazing” made from glass and display the relevant markings (see Note 2 and Table 1). 4. Vehicles having a maximum design speed greater than 40 km/h (25 mph) may not be fitted with a toughened windscreen. 5. All other windows (including sunroofs and removable glass panels) and side-screens must be “Safety Glazing” (which may be made from glass, or from plastic) and display the relevant markings (see Notes 2 & 3 and Table 1). 6. Windscreens and windows wholly or partly on either side of the driver’s seat must allow a visual transmission of at least 70%, or 60% in the case of an armoured vehicle (see Note 4). 7. Driver forward vision must not be distorted by the glazing material.

Table 1

Type of window	Relevant Markings (Mandatory) In addition to "E" approval	Supplementary Markings	Markings Not Allowed
Windscreen	I -for toughened glass II -for ordinary laminated glass III -for treated laminated glass IV -for glass-plastics glazing.		V - safety glazing having a regular light transmittance less than 70 per cent. VI - double-glazed unit VII - uniformly-toughened glass which can only be used as windscreens for slow-moving vehicles which, by construction, cannot exceed 40 km/h. VIII -In the case of rigid plastic glazing.
Windows wholly or partly on either side of the driver's seat	VIII -In the case of rigid plastic glazing. In addition, the appropriate application will be signified by: /B or /C Where plastic glazing has been submitted for abrasion resistance tests the following markings will also be applied: /L or /M	VIII/B for side, rear and roof glazing VIII/C in locations where there is little or no chance of head impact. /L will be added to one of the above where the glazing is requisite for the driver's forward field of vision.	V -in the case of safety glazing having a regular light transmittance less than 70 per cent. VII - uniformly-toughened glass which can only be used as windscreens for slow-moving vehicles which, by construction, cannot exceed 40 km/h.
Other windows and other glazed panels including internal glazed partitions.	VIII -In the case of rigid plastic glazing. In addition, the appropriate application will be signified by: /A , /B or /C Where plastic glazing has been submitted for abrasion resistance tests the following markings will also be applied: /L or /M	VIII/A for forward facing panes VIII/B for side, rear and roof glazing VIII/C in locations where there is little or no chance of head impact. /L will be added to one of the above where the glazing is requisite for the driver's forward field of vision. /M will be added to one of the above where the glazing is requisite for the driver's rearward field of vision.	VII - uniformly-toughened glass which can only be used as windscreens for slow-moving vehicles which, by construction, cannot exceed 40 km/h.

These symbols may be marked down in a different format i.e., **// - IV**

Laminated-glass

Means glazing consisting of two or more layers of glass held together by one or more interlayers of plastics material it may be:

"Ordinary", when none of the layers of glass of which it is composed has been treated **or**

"Treated", when at least one of the layers of glass of which it is composed has been specially treated to increase its mechanical strength and to condition its fragmentation after shattering.

Glass-plastics glazing

Means glazing consisting of any glazing material that comprises one layer of glass and one or more layers of plastic in which a plastic surface of the product faces the inner side.

Rigid plastic glazing

Means a plastic glazing material which does not deflect vertically more than 50 mm in the flexibility test

Glazing requisite for the driver's forward field of vision

Means all the glazing situated in front of a plane passing through the driver's seat reference 'R' point (see figure Section 31) perpendicular to the longitudinal centre line of the vehicle through which the driver can view the road when driving or manoeuvring the vehicle.

Glazing requisite for the driver's rearward field of vision

Means all the glazing situated behind a plane passing through the driver's seat reference 'R' point perpendicular to the longitudinal centre line of the vehicle through which the driver can view the road when driving or manoeuvring the vehicle.

Record of Revision

Revision	Date	Description of Change
1	18/04/2011	Version 1
2	31/10/2011	Add approval markings exemption for Armoured Vehicles (new paragraph 3)
3	05/10/2015	New RS 4 added, remaining RS renumbered, table 1 updated, definitions updated.
4	03/04/18	Expand MOI second paragraph.

46 Tyres

Application: All Vehicles (All Tyres)

Method of Inspection	Required Standard
<p>In the case of Armoured vehicles exemption from any requirement of this section is permitted if it can be demonstrated to the satisfaction of the Approval Authority that it is impossible for the vehicle to comply due to its special purpose.</p> <p>Note 1: It is acceptable that tyres displaying a 'VR' or 'ZR' rating do not display an 'E' or 'e' marking. Retreaded tyres must be approved and suitably e-marked according to UN Regulation No. 109, incorporating the manufacturers approval number as per the example below:</p> <div style="text-align: center; margin: 10px 0;"> <p>UNECE Type Approval mark</p>  <p>109 R - 002439</p> <p>a=12mm minimum</p> </div> <p>Note 2: Where the level of performance or safety provided is in question, the vehicle presenter must provide documentary evidence to demonstrate that the tyre would meet requirements equivalent to those of an 'E' or 'e' marked tyre.</p> <p>Note 3: A four-wheeled vehicle fitted with single wheels must not have:</p> <ul style="list-style-type: none"> • a crossply tyre or bias belted tyre fitted on the rear axle and a radial tyre fitted on the front axle • a crossply tyre fitted on the rear axle and a bias belted tyre fitted on the front axle. 	<ol style="list-style-type: none"> 1. Each tyre must bear an 'E', or 'e', DOT, or JIS approval mark (see Notes 1 & 2). 2. Each tyre must be manufactured so that it displays permanently the following service information: <ol style="list-style-type: none"> a. nominal size b. construction type (e.g., radial, cross ply, or bias belt) 3. Each tyre must be manufactured so that it displays permanently the following service information markings (see note in Annex 1) <ol style="list-style-type: none"> a. load capacity b. speed capability, or c. is accompanied by documentation that provides this information. 4. All tyres on the same axle must have the same structure (e.g., bias-belted, crossply, or radial) <ol style="list-style-type: none"> a. nominal size b. aspect ratio 5. Tyres must be of the correct structure, taking account of their position on the vehicle and the vehicle axle configuration (see Note 3). 6. Each tyre must be of the correct nominal size for the wheel to which it is fitted. 7. Each tyre must have an adequate speed capability (speed rating) for the maximum design speed of the vehicle (see Note 4 and Annex 1).

Method of Inspection	Required Standard
<p>Any tyre structure mix between different axles is acceptable for vehicles that have:</p> <ul style="list-style-type: none"> • two axles and 'twin' wheels on the rear axle • three axles, one steering and one driving. <p>Note 4: Evidence of, or a written declaration of, the maximum design speed of the vehicle should be produced by the vehicle manufacturer/owner.</p> <p>Note 5: Tyre tread depths are only required to be checked (using the digital tyre depth gauge) when it is visually obvious that there is a concern with that tyre.</p> <p>Note 6: Temporary-use spare this speed warning symbol / reference is only required for wheel and tyre combinations.</p>	<ol style="list-style-type: none"> 8. Each tyre must have the adequate load capacity for the axle to which it is fitted (see Annex 2 and 3) at the manufacturers stated maximum permitted axle weight (as indicated by documentary evidence or manufacturers plate) or where this is not available at the at the calculated maximum permitted axle weight. (for calculated axle weight see section 48). Note where both are available the higher value will be used. 9. Tyres must be fitted in accordance with the manufacturer's instructions as indicated on the side wall of the tyre 10. The load capacity of the temporary-use spare unit must be at least equal to one half of the highest of the maximum axle loads of the vehicle 11. For temporary use spare, an 80 km/h or 50mph maximum speed warning symbol / reference must be permanently displayed on the outer face of the wheel in a prominent position (see Note 6) 12. The grooves of the tread pattern must be, at least 1.6mm throughout a continuous band comprising of the centre $\frac{3}{4}$ of the breadth of tread around the outer circumference of the tyre (see Note 5).

Annex 1 Speed Categories

TABLE I

For speeds not exceeding 130mph the maximum load rating shall not exceed the value associated with the load capacity index of the tyre

TABLE II

For speeds higher than 130mph, but not exceeding 149mph, (tyres classified with speed category symbol “V”) the maximum load rating shall not exceed the percentage of the value associated with the load capacity index of the tyre, indicated in the table below, with reference to the speed capability of the car to which the tyre is fitted.

TABLE III

For speeds higher than 149mph, but not exceeding 168mph (tyres classified with speed category symbol “W”) the maximum load rating shall not exceed the percentage of the value associated with the load capacity index of the tyre, indicated in the table below, with reference to the speed capability of the car to which the tyre is fitted.

TABLE IV

For speeds higher than 168mph, but not exceeding 186mph (tyres classified with speed category symbol “Y”) the maximum load rating shall not exceed the percentage of the value associated with the load capacity index of the tyre, indicated in the table below, with reference to the speed capability of the car to which the tyre is fitted.

NOTE: On radial-ply tyres suitable for higher speeds, the letter ‘R’ in the tyre designation (placed in front of the rim diameter) may be replaced by ‘VR’ or ‘ZR,’ e.g., 205/55ZR16.

Tyres displaying the “VR” or “ZR” marking may not display a load index or speed rating.

If a tyre load capacity is displayed and is suitable, documentary evidence of the tyre speed capability is only necessary if the vehicle maximum road speed is in excess of 130mph (in the case of a vehicle fitted with a “VR” tyre) or 149mph (in the case of a vehicle fitted with a “ZR” tyre)

For tyres suitable for speeds in excess of 300 km/h (186 mph), the maximum speed permitted by the tyre manufacturer and the load carrying capacity allowed for that maximum speed, evidence in the form of tyre specification documentation from the manufacturer will be required.

If a tyre load capacity is not displayed manufacturer’s evidence of its capabilities will be required.

A tyre marked with a load capability in lbs./kg is only acceptable providing it also indicates its speed capability, otherwise manufacturer’s evidence/information will be required.

Table 1

Speed Category Symbol	Corresponding Speed	
	(km/h)	(mph)
L	120	75
M	130	81
N	140	87
P	150	93
Q	160	99
R	170	106
S	180	112
T	190	118
U	200	124
H	210	130
V	240	149 - see Table 2
W	270	168 - see Table 3
Y	300	186 - see Table 4

Table 2

Maximum Speed		Load (%)
(km/h)	(mph)	
215	134	98.5
220	137	97
225	140	95.5
230	143	94
235	146	92.5
240	149	91

Table 3

Maximum Speed		Load (%)
(km/h)	(mph)	
240	149	100
250	155	95
260	162	90
270	168	85

Table 4

Maximum Speed		Load (%)
(km/h)	(mph)	
270	168	100
280	174	95
290	180	90
300	186	85

Annex 2 Tyre Capacity Tables (Ply Rated Tyres)

Tyre Size	Ply Rating	Maximum Axle Loads Kg		Tyre Size	Ply Rating	Maximum Axle Loads Kg	
		Single	Twin			Single	Twin
500-10	6	740	-	205-14	RADIAL	1420	2820
145-12C	6	920	1740	205-14	REINFORCED RADIAL	1650	3160
145-12C	8	1060	2000	205-14C	6	1850	3510
155-12C	6	980	1850	205-14C	8	2060	3900
550-12C	6	850	1600	215-14C	8	2240	4240
600-12C	6	980	1880	590-14C	6	1170	2240
700-12	12	2550	4800	600-14C	8	1260	2400
700-12	14	2750	5090	640-14C	6	1330	2550
145-13C	6	970	1840	650-14	4	970	1860
145-13C	8	1120	2120	650-14C	6	1300	2460
165-13	4	920	-	650-14C	8	1500	2840
175-13	6	1340	2520	670-14C	6	1430	2750
560-13C	6	1020	1940	670-14C	8	1680	3160
590-13C	6	1070	2090	700-14	4	1070	2050
640-13C	6	1280	2240	700-14C	6	1380	2650
640-13C	8	1430	2750	750-14	4	1200	2300
670-13C	6	1380	2650	750-14C	6	1530	2950
670-13C	8	1580	3050	750-14C	8	1730	3360
1050-13	12	4320	7880	11-15	6	2240	-
1050-13	14	4830	8900	145-15C	8	1230	2320
155-14C	6	1070	2040	185-15C	8	1750	3400
165-14C	6	1300	2460	590-15C	6	1220	2340
165-14C	8	1460	2760	640-15C	6	1380	2650
175-14C	6	1430	2680	670-15C	6	1530	2900
175-14C	8	1550	3000	670-15C	8	1780	3460
185-14	RADIAL	1200	2300	670-15	10	2000	3900
185-14	REINFORCED RADIAL	1340	2560	700-15C	6	1750	3400
185-14	4	1340	2560	700-15C	8	1940	3760
185-14C	6	1550	2920	700-15	12	2440	4580
185-14C	8	1700	3200	750-15C	6	1830	3560
195-14	RADIAL	1300	2490	750-15C	8	2060	3970
195-14	REINFORCED RADIAL	1500	2870	750-15	10	2340	4370
195-14C	6	1700	3210	750-15	12	2750	5340
195-14C	8	1900	3600	750-15	14	3150	6100
				750-15	16	3660	6860

Tyre Size	Ply Rating	Maximum Axle Loads Kg			Tyre Size	Ply Rating	Maximum Axle Loads Kg	
		Single	Twin				Single	Twin
825-15	12	3050	5590		700-16	6	1370	3260
825-15	14	3360	6360		700-16	8	2040	3870
825-15	18	4680	8540		700-16	10	2340	4480
825-15	20	5000	9440		700-16	12	2650	5000
1000-15	12	3870	7120		750-16	6	2040	3870
1000-15	14	4320	8130		750-16	8	2240	4270
1000-15	16	5020	9580		750-16	10	2500	4720
1000-15	18	5400	10170		750-16	12	2900	5600
175-16C	6	1500	2840		825-16	8	2650	4880
175-16C	8	1650	3100		825-16	10	2850	5440
185-16C	8	1800	3400		825-16	12	3300	6400
195-16C	8	1950	3700		825-16	14	3600	6800
205-16C	6	1900	3610		900-16	6	2360	4360
205-16C	8	2120	4000		900-16	8	2720	5140
215-16C	6	2120	4000		900-16	10	3050	5600
215-16C	8	2300	4360		900-16	12	4070	7200
235/85-16	10	2760	5040		900-16	14	4320	7800
600-16	6	1380	2550					
600-16	8	1530	2920					
600-16	10	1830	3300					
650-16	6	1530	2920					
650-16	8	1830	3460					
650-16	10	2040	3900					

Annex 3 Tyre Capacity Tables (Load Index Tyres)

Load Index	Single Kg	Twin Kg	Load Index	Single Kg	Twin Kg	Load Index	Single Kg	Twin Kg
70	670	1340	107	1950	3900	144	5600	11200
71	690	1380	108	2000	4000	145	5800	11600
72	710	1420	109	2060	4120	146	6000	12000
73	730	1460	110	2120	4240	147	6150	12300
74	750	1500	111	2180	4360	148	6300	12600
75	774	1548	112	2240	4480	149	6500	13000
76	800	1600	113	2300	4600	150	6700	13400
77	824	1648	114	2360	4720	151	6900	13800
78	850	1700	115	2430	4860	152	7100	14200
79	874	1748	116	2500	5000	153	7300	14600
80	900	1800	117	2570	5140	154	7500	15000
81	924	1848	118	2640	5280	155	7750	15500
82	950	1900	119	2720	5440	156	8000	16000
83	974	1948	120	2800	5600	157	8250	16500
84	1000	2000	121	2900	5800	158	8500	17000
85	1030	2060	122	3000	6000	159	8750	17500
86	1060	2120	123	3100	6200	160	9000	18000
87	1090	2180	124	3200	6400	161	9250	18500
88	1120	2240	125	3300	6600	162	9500	19000
89	1160	2320	126	3400	6800	163	9750	19500
90	1200	2400	127	3500	7000	164	10000	20000
91	1230	2460	128	3600	7200	165	10300	20600
92	1260	2520	129	3700	7400	166	10600	21200
93	1300	2600	130	3800	7600	167	10900	21800
94	1340	2680	131	3900	7800	168	11200	22400
95	1380	2760	132	4000	8000	169	11600	23200
96	1420	2840	133	4120	8240	170	12000	24000
97	1460	2920	134	4240	8480	171	12300	24600
98	1500	3000	135	4360	8720	172	12600	25200
99	1550	3100	136	4480	8960	173	13000	26000
100	1600	3200	137	4600	9200	174	13400	26800
101	1650	3300	138	4720	9440	175	13800	27600
102	1700	3400	139	4860	9720	176	14200	28400
103	1750	3500	140	5000	10000	177	14600	29200
104	1800	3600	141	5150	10300	178	15000	30000
105	1850	3700	142	5300	10600	179	15500	31000
106	1900	3800	143	5450	10900			

Record of Revision

Revision	Date	Description of Change
1	18/04/2011	Version 1
2	31/05/2012	Amend RS8 – reference to section 44 now section 48
3	11/03/2013	Revise last sentence then insert new sentence in Annex 1
4	22/05/2023	Expand Annex 1 to include reference to Tyres rated in excess of 300 km/h (186 mph) (TSE N1 046 002) and Note 1 to include requirements for Retreaded tyres.
5	09/10/2024	Annex 3 Tyre capacity table (Load index tyres): Corrected duplicate Load index rating 101 to 100.

48 Masses and Dimensions

Application: All Vehicles

Method of Inspection	Required Standard
<p>All vehicles must not exceed the maximum permitted authorised dimensions.</p> <p>In the case of unmodified Mass Produced vehicles RS 3- 9 shall be considered to be met. The installation of a body on a chassis constitutes a ‘completed’ vehicle and is not to be considered a modification unless the new declared weights exceed the approved weights of the unmodified base vehicle.</p> <p>Ideally the vehicle should be accompanied with declared maximum permissible weights and relative evidence, however other than in the case of the maximum permissible towing mass (which must be provided if the vehicle is equipped to tow) where they are not available the weights determined by this section will be utilised for other sections such as 09 Braking and 46 Tyres.</p> <p>Where maximum weights have been provided, check the evidence to ensure that the weights were allocated by the vehicle manufacturer, on mass produced vehicles this may take the form of a VIN plate (see Section 18).</p> <p>Note 1: For the superstructure of vehicles designed for transport of goods under controlled temperatures the maximum width is 2.6 metres</p>	<ol style="list-style-type: none"> 1. The vehicle must not exceed the maximum length of 12 metres (see Annex 1). 2. The vehicle must not exceed the maximum width of 2.55 metres (see Annex 1 and Note 1). 3. Where declared the vehicle must be accompanied by satisfactory evidence of the maximum design weights, which have been assigned to the vehicle by the manufacturer. 4. The sum of the design axle weights must be equal to or greater than the maximum gross vehicle weight. 5. The maximum design gross weight must be equal to or greater than the calculated weights. 6. The maximum design front axle weight must be equal to or greater than the calculated weight. 7. The maximum design rear axle weight must be equal to or greater than the calculated weight. 8. When a vehicle is loaded to its maximum permitted gross weight and its rear axle is loaded to its maximum permitted weight, the front axle weight must not be less than 30% of the maximum gross vehicle weight.

Masses and Dimensions 48

Method of Inspection	Required Standard
<p>Note 2: Where a mass produced vehicle has been modified, or an axle has been used during the build of a new vehicle and the vehicle/axle weight appears to be heavier than the original vehicle/axle weight then evidence that the modifications justify the increased weights must be provided. This applies for example in the case of a stretched limousine.</p> <p>Axle Weight Calculations</p> <p>For mass produced vehicles / base vehicles where the original manufacturer’s fuel system / tank are retained, and design weight requirements have been declared full fuel tanks are not required. For these vehicles the missing fuel volume should be ascertained and added to the presented weight.</p> <p>a. Obtain the “kerbside weight” of each axle using the provided equipment.</p> <p>The “kerbside weight” is the weight of the vehicle as presented, with no driver or passengers, a full fuel tank, an adequate supply of the necessary oils, water, fluids etc., and no load other than tools and equipment normally carried.</p> <p>b. Using the “kerbside weight” and the appropriate passenger / load weight, calculate (see Annex 2)</p> <ul style="list-style-type: none"> • the maximum permitted weight of each axle • the maximum gross vehicle weight. <p>The passenger / load weight to be used in the calculation is 68kg in each seat (including the driver’s seat) designated for use while the vehicle is traveling on the road, plus the load (which, if available, should be centrally located in the load space area).</p>	<p>9. Where an original axle design weight appears to have been exceeded evidence to increase the weights must be provided (see Note 2).</p> <p>10. A vehicle which is capable of towing must have a technically permissible towing mass which conforms with the information below:</p> <p>a. Where a vehicle is capable of towing a trailer fitted with a service braking system, the technically permissible maximum towable mass of the vehicle must not exceed either of:</p> <ul style="list-style-type: none"> • the technically permissible mass of the towing vehicle OR, for off- road vehicles, 1.5 times that mass (see Note 3). • 3500Kg. <p>b. Where a vehicle is only capable of towing a trailer which is not fitted with a service braking system, then the technically permissible towable mass of the vehicle must not exceed either of;</p> <ul style="list-style-type: none"> • half of the mass of the towing vehicle in running order, • 750kg. <p>Installation of retractable or loadable axles:</p> <p>11. If a vehicle is fitted with one or more loadable axles, satisfactory evidence must be provided stating that under all driving conditions, the axle will lower to the ground automatically when the front axle or the nearest axle of a group of axles is loaded.</p> <p>Turning Circle Requirements: (see Note 4)</p> <p>12. The motor vehicle must be able to manoeuvre for a complete circular trajectory of 360 degrees within the defined area (with the exception of the protruding parts prescribed for the vehicle width shown in Annex 1) (see Note 4 & Figure 1).</p>

Method of Inspection	Required Standard
<p>Note 3: Vehicles submitted for test will be un-laden and should be well within the permissible weights set out in Annex 1 to section 18. However, if it seems likely that the vehicle or an axle (as presented) exceeds any of these weights, the vehicle must be weighed where possible, or a weight ticket must be requested.</p> <p>Note 4: Check that the vehicle is able to manoeuvre a complete circular trajectory of 360 degrees inside an area defined by two concentric circles, without any of the vehicles outermost points projecting outside the circumferences of the circles (See figure 1).</p> <p>This must be completed on both steering locks</p> <p style="padding-left: 40px;">The outer circle having a radius of 12.50 metres The inner circle having a radius of 5.30 metres</p> <p>Note 5: When the vehicle is stationary facing the circle establish a vertical plane and mark this on the ground alongside the vehicle. (see figure 2)</p> <p>When the vehicle enters the circle as described above no part of it shall move outside of this by prescribed limits in required standard 13. This procedure must be carried out on both sides</p> <p>In the case of unmodified Mass Produced vehicles, the turning circle requirements in this section shall be considered to be met.</p> <p>Where evidence suggests that the vehicle has been modified, the examiner shall assess whether the modification would be likely to materially affect the steering performance and if so, carry out assessment against RS 12 and 13.</p>	<p>13. Any part of the vehicle must not move outside of the vertical plane by more than 0.8 metres, or for vehicles with retractable axles in the lifted position, or loadable axles in the un-laden condition, the figure of 0,80 m is replaced by 1,00 m. (For vehicles with an axle-lift device this requirement also applies with the axle(s) in the lifted position) (see Note 5 & Figure 1).</p>

Figure 1

Vehicle has to remain in between the 2 circles for a full 360 degrees

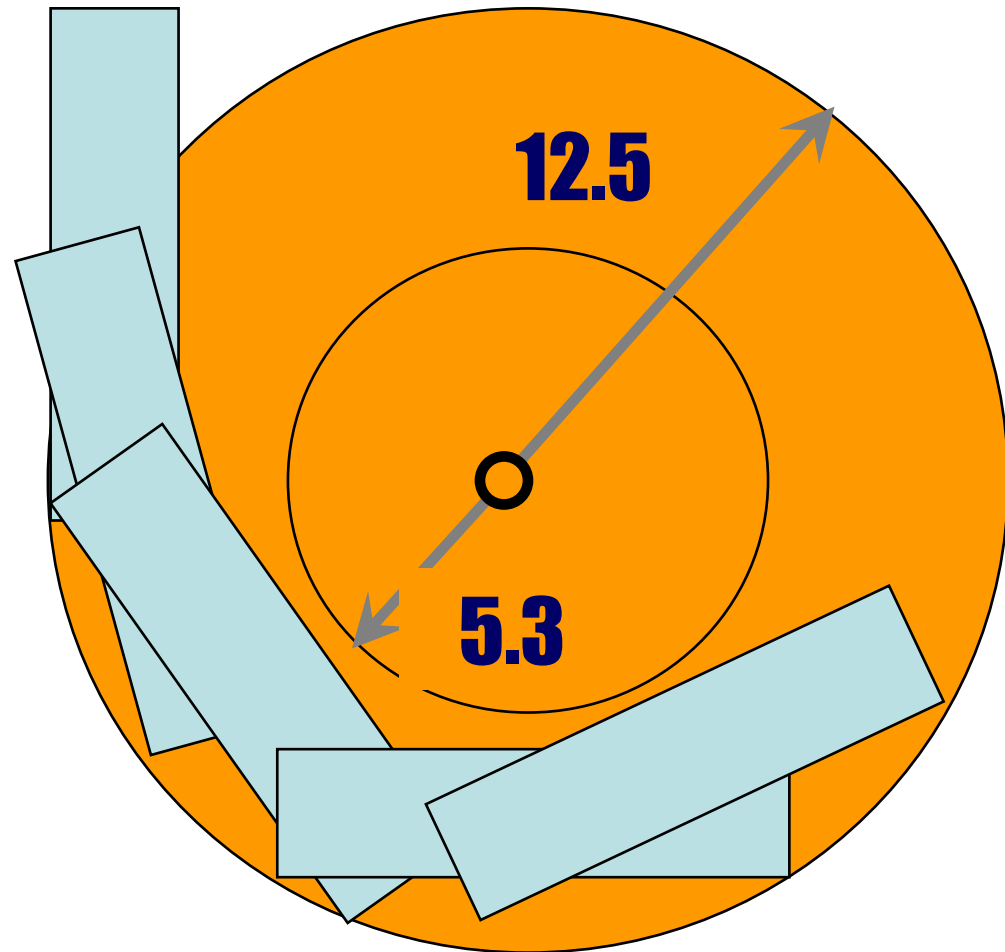
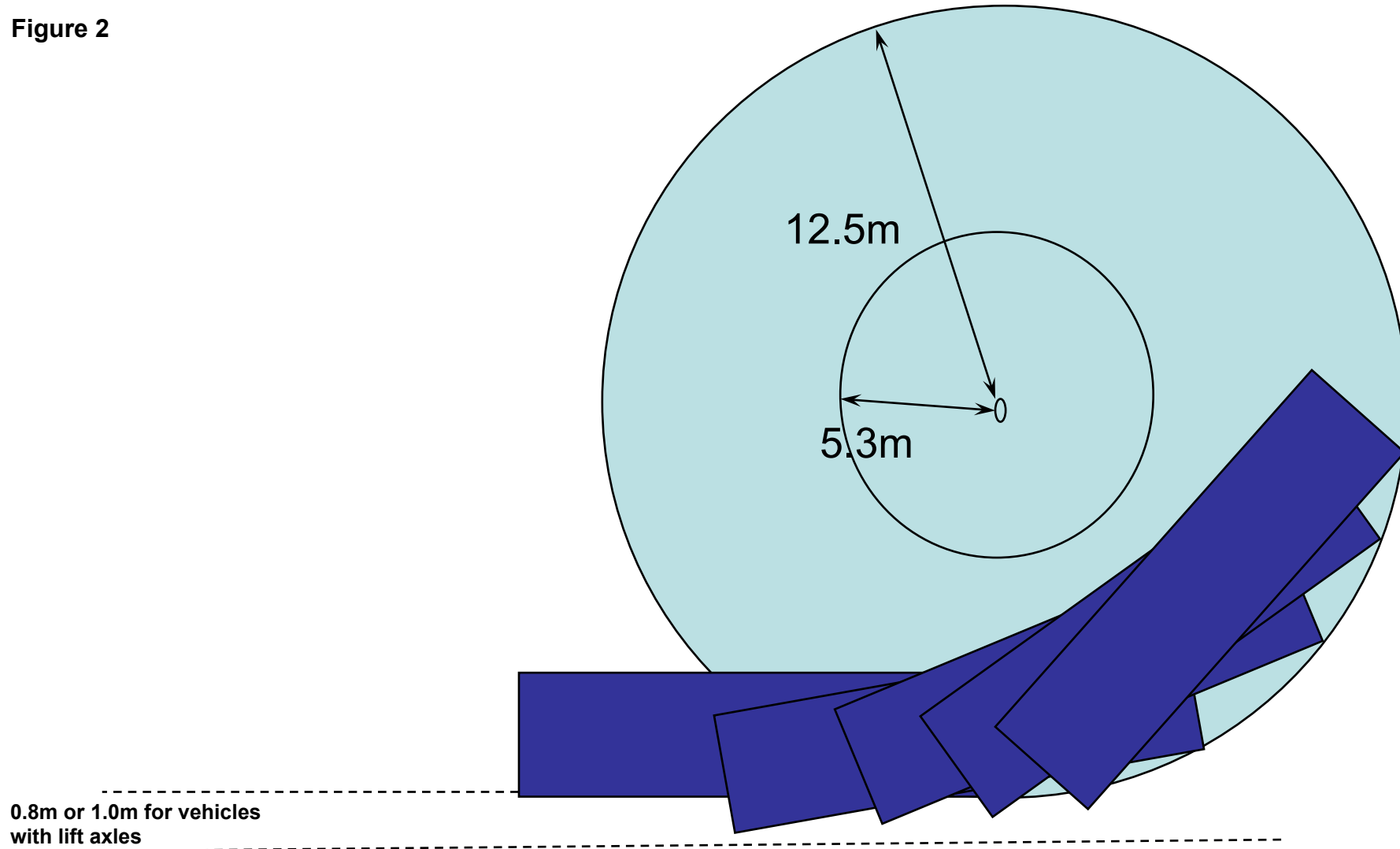

Figure 2



Annex 1

Items to be excluded from measurement of length and width.

A - Items to be excluded when measuring Length	B - Items to be excluded when measuring Width
<ul style="list-style-type: none"> • wiper and washer devices, • front or rear registration plates, • lighting equipment, • mirrors and other devices for indirect vision, access steps and hand-holds, lifting platforms, access ramps, and similar equipment when undeployed or in the position they would be on a moving vehicle, not exceeding 300 mm, and providing that the loading capacity of the vehicle is not increased, • coupling devices, • trolley booms of electrically-propelled vehicles, • external sun visors 	<ul style="list-style-type: none"> • tyre-pressure or tyre failure indicators, • protruding flexible parts of wheel guards • lighting equipment, • mirrors and other devices for indirect vision, • access ramps, lift platforms and similar equipment (when undeployed and provided that they do not exceed 10 mm from the side of the vehicle, and the edges must be rounded to a radius of not less than 2.5 mm. The corners of any ramp facing forwards or rearwards must be rounded to a radius of not less than 5 mm) and that the requirements of section 49 (Exterior Projections of Cabs) are met, • retractable steps, • the deflected part of the tyre walls immediately above the point of contact with the ground, • handles and hinges of external lockers, • locking catches on a tipper type body • trim protruding not more than 10mm from the bodywork, • side mounted carrying rack/glass frail

Annex 2: Calculation of Maximum Permitted Axle Weight and Maximum Gross Weight

EXAMPLE 1 Single cab pick-up: All dimensions in meters

This example assumes

- a. The kerb weight of Axle 1 = 650kg
 Axle 2 = 400kg
 Load = 800kg
- b. The single row of seats consists of 2 seats.
- c. The passenger/driver weight of 68kg per seat distributed
 - 68kg in each seated position (total 136kg)

Using the vehicle foremost point as a datum, taking moments on Axle 1.

$$\begin{aligned}
 & ((2-1) \times (68 \times 2)) + ((3-1) \times (800)) \\
 &= (1 \times 136) + (2 \times 800) = 136 + 1600 = 1736\text{kg} \\
 &= \frac{1736}{3.5} = 496\text{kg} = \text{additional load on rear axle}
 \end{aligned}$$

Maximum rear axle weight = 496kg + kerb weight (400kg) = 896kg

Gross weight = kerb weight (1050kg) + passenger weight (136kg) + Load (800kg) = 1986kg

Max front axle weight = gross weight (1986kg) – rear axle weight (896kg) = 1090kg

NOTE: Seat dimensions must be taken

- a. in the case of an adjustable seat
 - with the seat in the rearmost position
 - to a point 250mm forward of the base of the backrest.
- b. in any case to a point 200mm forward of the base of the backrest
- c. Where the vehicle has the facility to tow, the above calculation must be done to also include an additional moment from the datum point to the centre of the tow ball using a weight of 100Kg (unless evidence suggests otherwise).
 (The towing device must be fitted so that the weight of it is included when weighing the front and rear axles)

NOTE: Information regarding the load and its position must be provided by the presenter.

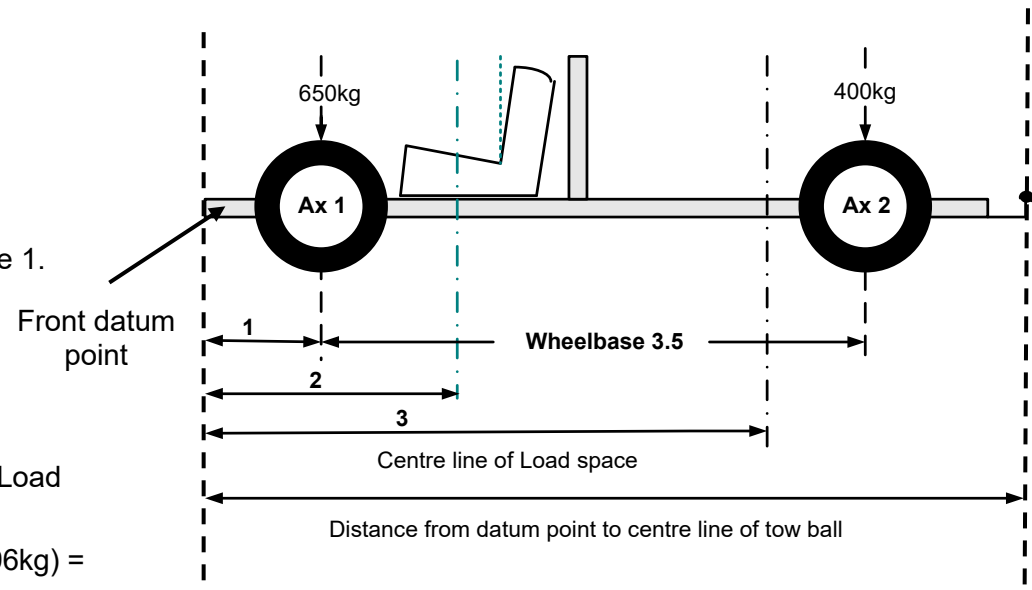

EXAMPLE 2 Crew cab pickup: All dimensions in meters

This example assumes

- a. The kerb weight of Axle 1 = 650kg
 Axle 2 = 400kg
 Load = 800kg
- b. Each row of seats consists of 2 seats.

The passenger/driver weight of 68kg per seat distributed 68kg in each seated position (total 272kg)

Using the vehicle foremost point as a datum, taking moments on Axle 1.

$$\begin{aligned}
 & ((2-1) \times (68 \times 2)) + ((3-1) \times (68 \times 2)) + ((4.5-1) \times 800) \\
 &= (1 \times 136) + (2 \times 136) + (3.5 \times 800) \\
 &= 136 + 272 + 2800 \\
 &= \frac{3208}{4.5} = 712.9\text{kg} = \text{additional load on rear axle}
 \end{aligned}$$

Maximum rear axle weight = 712.9kg + kerb weight (400kg) = 1112.9kg

Gross weight = kerb weight (1050kg) + passenger weight (272kg) + Load (800kg) = 2122kg

Max front axle weight = gross weight (2122kg) – rear axle weight (712.9kg) = 1409.1kg

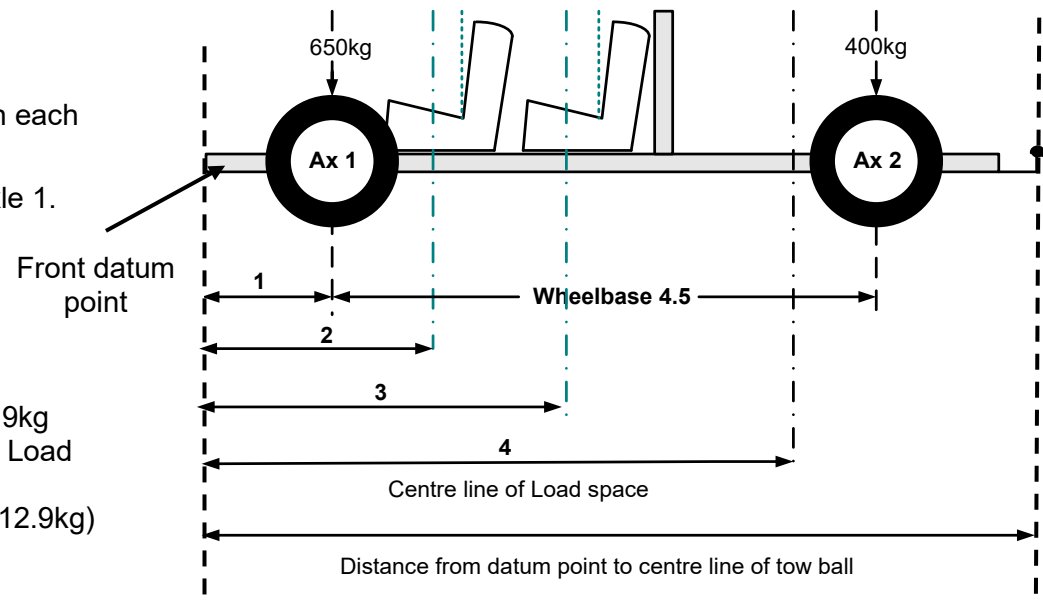

NOTE: Seat dimensions must be taken

- a. in the case of an adjustable seat
 - with the seat in the rearmost position
 - to a point 250mm forward of the base of the backrest.
- d. in any case to a point 200mm forward of the base of the backrest
- e. Where the vehicle has the facility to tow, the above calculation must be done to also include an additional moment from the datum point to the centre of the tow ball using a weight of 100kg (unless evidence suggests otherwise).
 (The towing device must be fitted so that the weight of it is included when weighing the front and rear axles)

NOTE: Information regarding the load and its position must be provided by the presenter.

Record of Revision

Revision	Date	Description of Change
1	18/04/2011	Version 1
2	31/10/2011	Insert new Note 1, renumber Notes and reformat Section
3	31/05/2012	Revise axle weight calculations (MOI) and insert missing Annex 2
4	11/02/2013	Revise Note 1, text in last sentence of Axle Weight Calculations and add notes to Examples 1 & 2 in Annex 2.
5	05/10/2015	Expand para 2 in MOI, new para in Axle Weight Calculations, correct reference in Annex 1 B and add further exemption, additional note in Annex 2 examples
6	03/04/2018	Correct alignment of Notes in MOI.
7	22/05/2023	Clarify access ramps, lift platforms, retractable steps, and similar equipment requirements in Annex 1 Table for Length and Width

This page intentionally left blank

49 Exterior Projections of Cabs

Application: All Vehicles

Method of Inspection	Required Standard
<p>The cab area of Vehicles must not display any features likely to increase the risk of injury to other road users.</p> <p>In the case of unmodified Mass-Produced vehicles (cabs) the standards in this section shall be considered to be met.</p> <p>In considering if an item meets the requirements of this section, the examiner will compare the materials and methods used to those employed by a Major Vehicle manufacturer or to examples found on Approved vehicles. Items such as covers (rubber or otherwise) that are held in place by being stretched on or attached by double sided tape or other inadequate means, rubber hosing, pipe lagging etc are not considered acceptable methods or materials. This is not an exhaustive list but provided as guidance as to the type of item considered to be unacceptable.</p> <p>In the case of an Armoured vehicle, exemption from one or more of the requirements is permitted where it can be demonstrated to the satisfaction of the Approval Authority that the special purpose of the vehicle makes it impossible to fully comply.</p> <p>Where a vehicle is adapted for surveying the highway (Highway Testing Vehicle) the adaptation will not be subject to the requirements of this section.</p>	<ol style="list-style-type: none"> 1. A mascot, emblem or other ornamental object must retract or detach when a reasonable force is applied and leave a base or mounting free from sharp edges that does not protrude from the surface by more than 10mm. 2. All 'hard' parts contactable with a 100mm sphere, which form an external surface or protrude 5mm or more from the external surface must have a radius of curvature of at least 2.5mm (see Notes 1, 3, 6 & 7). <p>The criteria of Standard 2 DOES NOT apply to the following, which must be checked to their individual requirements:</p> <ol style="list-style-type: none"> 3. Protrusions less than 5mm contactable with a 100mm sphere must have blunted edges (see Notes 1 & 3). 4. Wheel arches must be 'turned inwards' or have a radius of curvature of at least 2.5mm. 5. Grills, gaps, slots, grooves, channels, recesses, and holes that have a width of 10mm or less as determined by the contact points of a 100mm sphere must be blunted (see Note 4). 6. Grills, gaps, slots, grooves, channels, recesses, and holes which have a width of more than 10mm and up to 25mm determined by the contact points of a 100mm sphere must be blunted (see Note 4).

Exterior Projections of Cabs 49

Method of Inspection	Required Standard
<p>Exterior projections will be assessed between the 'floor line' and a height of 2 metres from the ground extending rearwards to a plane passing across the rear of the cab (see note 1) and includes damaged, modified, or repaired bodywork. The theoretical floor line is determined by the series of contact points formed between the vehicle and the application of a curved area of a cone segment. The curved area is at an angle of 30 degrees from the vertical. The points of contact are used as a guide to judge the actual floor line i.e., Certain items that the cone contacts are likely to move or offer little resistance prior to detaching and are therefore excluded from the actual floor line. In addition, where the cone contacts 2 or more points and cannot contact other items that may determine the floor line a judgement will be made as to where the cone would contact the other items. Jacking points, exhaust pipes (only where the tail pipe protrudes from under the body – side mounted exhausts may actually provide the points of contact that form the floor line) and wheels are not taken into consideration when the floor line is being determined. Wheel arches are assumed to be filled in exempting any projection inboard of the turned in edge of the wheel arch. Note the floor line itself is subject to the requirements of RS2 i.e., the 2.5mm radius requirement applies.</p> <p>'Radius' refers to the external radius of curvature.</p> <p>'Blunted edges' are those which under finger and thumb pressure alone would not be likely to cut the skin.</p> <p>'Cab rear panel' means the rearmost transverse panel of the external surface of the driver and passenger compartment. Where it is not possible to determine the position of the cab rear panel it would be deemed to be the vertical transversal plane situated 50 cm to the rear of the R point of the driver's seat, with the driver's seat, if adjustable, located at its rearmost driving position. If the cab is fitted with more than one row of seats, the rearmost passenger seat in its rearmost</p>	<ol style="list-style-type: none"> 7. Grills, gaps, slots, grooves, channels, recesses, and holes which have a width of more than 25mm, and up to 40mm determined by the contact points of a 100mm sphere must have a radius of curvature of at least 1mm (see Note 4). 8. Grills, gaps, slots, grooves, channels, recesses, and holes which have a width of more than 40mm determined by the contact points of a 100mm sphere must have a radius of curvature of at least 2.5mm (see Note 4). 9. Where contactable with the 100mm sphere sheet metal edges must be folded back on themselves (180 degrees). 10. Where contactable with the 100mm sphere a glass/fibre reinforced plastic panel edge must have a radius of curvature of at least 1.5mm. 11. Wiper blades and their support arms must be at least blunted. 12. Wheel nuts, hub caps and protective devices must not exhibit any fin-shaped projections. 13. Protective device(s) with a radius of curvature of at least 5mm must be fitted to wheel securing bolts, nuts, or hubs if they protrude beyond the upper half of the tyre surface. The protective devices which cover wheel nuts and hubs may project beyond the body plan by no more than 30 mm. 14. The upper half of a wheel must not protrude beyond the cab body plan form (disregarding tyres). 15. The edges on lateral air and rain deflectors and window anti-smear air deflectors, capable of being directed outwards must have a radius of curvature of not less than 1 mm.

Exterior Projections of Cabs 49

Method of Inspection	Required Standard
<p>position has to be taken into account for the definition of the rear cab panel. The rear panel is excluded from the requirements of this section.</p> <p>Note 1: The measurement of a protrusion is taken from the “external surface”. The external surface is the first surface that the 100mm sphere can contact nearest to the protrusion in question. Where the sphere does not touch a surface (possibly due to the length of the projection) or contacts a further projection, a simple measurement from the projections mounting surface will be made</p> <p>Note 2: For grab handles the projection is measured in relation to a plane passing through the points of attachment.</p> <p>Note 3: A ‘hard’ feature is a feature which has a hardness of at least 60 Shore A (as a guide, deemed to be harder than the average pencil eraser).</p> <p>Note 4: The distance between parts of a grille is the distance between two planes passing through the points of contact of the sphere and perpendicular to the line joining the points of contact.</p> <p>The IVA test plate (referred to in Section 4 Rear Registration Plate Space) will be placed on any front number plate mountings provided. This will allow the area around the plate and its mountings to be assessed correctly.</p> <p>Note 5: This does not apply to Emergency Stop Buttons used by auxiliary equipment fitted to the vehicle.</p>	<p>16. Aerial shafts must be blunted and fitted with a ‘fixed end capping’ with a radius of curvature of at least 2.5mm.</p> <p>17. The ends of front protective devices (bumpers) must be turned inwards towards the external surface of the body.</p> <p>18. The components of bumpers projecting 5mm or more must be so designed that all rigid surfaces facing outwards have a radius of curvature of not less than 5 mm. The edges of devices projecting less than 5 mm must be blunted.</p> <p>The following Standards must be met IN ADDITION to Standard 2:</p> <p>19. Equipment such as towing hitches and winches must not protrude beyond the foremost surface of the bumper. However, winches may protrude beyond the foremost surface of the bumper provided they are covered when not in use by a suitable protective covering having a radius of curvature of not less than 2.5 mm.</p> <p>20. Push buttons must not protrude more than 30mm (see Note 5).</p> <p>21. Handles (other than grab handles), hinges, and fuel tank filler caps must not protrude more than 50mm.</p> <p>22. Grab handles and bonnet fasteners must not project more than 70mm.</p> <p>23. Headlight visors and rims must not project more than 30mm beyond the lens surface (measured horizontally from the point of contact of a 100mm sphere touching lens and visor/rim or the adjacent bodywork and the visor/rim if the lamp is recessed).</p>

Exterior Projections of Cabs 49

Method of Inspection	Required Standard
<p>Note 6: Safety cameras fitted to vehicles for the protection of unprotected road users will not be subject to the 2.5mm radius requirements they only need to be blunted, protective shields /guards fitted for these devices are still subject to the normal criteria of the section.</p> <p>Note 7: A base vehicle that is not mass produced having windows that can be moved (e.g., up/down) that are contactable with the 100mm sphere must have any exposed window edges at least blunted.</p>	<p>24. Handles that rotate or pivot outwards must be enclosed in a protective surround or be recessed unless they cannot in any circumstance project beyond the extreme outer edge of the cab.</p> <p>25. Handles that rotate parallel to the plane of the panel must be turned inwards towards the plane of the panel.</p> <p>26. The open end of any handle that rotates parallel to the plane of the panel and protrudes beyond the extreme outer edge of the cab must face rearwards.</p> <p>27. Any handle that does not protrude beyond the extreme outer edge of the cab must have:</p> <ul style="list-style-type: none"> a. The open end facing rearwards, or b. the open end shielded to the front by a protective surround, or c. the open end recessed into the bodywork, or d. a gap measuring a maximum of 2mm between the open end of the handle and the vehicle body. <p>28. Handles that pivot outwards must have the open end facing rearwards or downwards unless they have an independent return mechanism which in event of failure will not allow the handle to project more than 15mm.</p> <p>29. An exhaust tailpipe must not project beyond the floor line or the vertical projection of the intersection of the reference plane with the external surface of the vehicle lying directly above it by more than 10mm unless it terminates in a radius of curvature of at least 2.5mm.</p>

Record of Revision

Revision	Date	Description of Change
1	18/04/2011	Version 1
2	31/07/2011	Insert the word front before 'number plate mountings' in the paragraph after Note 4 and insert new Note 5
3	05/10/2015	Information relating to Highway Testing Vehicles added to MOI
4	01/07/2018	New Note 6, referenced from RS 2 added.
5	22/05/2023	New Note 7, referenced from RS 2 added.

This page intentionally left blank

50 Couplings

Application: All Vehicles

Method of Inspection	Required Standard						
<p>This section applies to all devices that have been fitted post vehicle manufacture. Typically comprising a separate frame attached to the vehicle structure.</p> <p>Assessment must be made of the vehicle structure to which the coupling device is attached to ensure it is of sufficient strength, relevant to the coupling device fitted. This will include any fixings used. This may be either:</p> <ul style="list-style-type: none"> Approval relevant to the vehicle Visual examination and assessment of the surrounding area <p>Check the security of the coupling ball and towing bracket</p> <ul style="list-style-type: none"> The number and grade of securing bolts required Whether appropriate reinforcement or load spreader plates are fitted. The coupling ball must not be mounted so as to obscure the place or visibility of the rear licence plate. If it is mounted in this area, then a coupling ball that can be dismantled without special tools has to be used. <p>Check installation height of the coupling and that there is sufficient clearance around it to enable safe operation.</p> <table border="1" style="width: 100%; margin-top: 10px; border-collapse: collapse;"> <thead> <tr style="background-color: #cccccc;"> <th style="width: 50%; text-align: center;">Minimum Height</th> <th style="width: 50%; text-align: center;">Maximum Height</th> </tr> </thead> <tbody> <tr> <td style="text-align: center;">375 mm</td> <td style="text-align: center;">500 mm</td> </tr> <tr> <td colspan="2" style="text-align: center;">Coupling height requirements measured (vehicle unladen) to the top of the ball</td> </tr> </tbody> </table> <p>Note 1: Where the relevant ‘e’ markings are not visible due to the installation method, the presenter may provide evidence that the coupling used is appropriately marked.</p>	Minimum Height	Maximum Height	375 mm	500 mm	Coupling height requirements measured (vehicle unladen) to the top of the ball		<ol style="list-style-type: none"> 1. The coupling device(s) must be of an approved type and have the correct markings (see Notes 1 & 3). 2. The coupling frame must bear an ‘e’ or ‘E’ mark to ensure the construction of the device meets the appropriate approval criteria. 3. The coupling device(s) must be securely mounted to the vehicle. 4. The vehicle structure, to which the coupling is attached, and any fixings used must be of sufficient strength relevant to the coupling fitted. 5. The coupling ball and / or towing bracket must be installed to the correct height (see Note 2). 6. If a coupling device is fitted then the vehicle must be provided with a Gross Train Weight, which must satisfy the requirements of Section 48.
Minimum Height	Maximum Height						
375 mm	500 mm						
Coupling height requirements measured (vehicle unladen) to the top of the ball							

Method of Inspection	Required Standard
<p>Note 2: Minimum and maximum height requirements not required on off-road vehicles as defined in 'Glossary of Terms'.</p> <p>Note 3: Modular coupling receivers, typically found on vehicles produced in North America are integrated into the construction of the vehicle during manufacture and are therefore outside of the scope of this Section.</p>	

Record of Revision

Revision	Date	Description of Change
1	18/04/2011	Version 1
2	31/10/2011	Insert new Note 1 , and reword RS1
3	11/03/2013	Remove paragraph 2 from Mol
4	05/10/2015	Amend table in Note 2
5	03/04/18	New RS4, renumber following RS. New paragraph in MOI and table repositioned.
6	01/07/2018	Note 3 referenced from RS1.

This page intentionally left blank

60 Frontal Protection System (Bull bar)

Application: All Vehicles (where fitted)

Method of Inspection	Required Standard
<p>Ensure the vehicle has satisfactory evidence of compliance to the required standard as presented and has a genuine 'e' mark that was applied at the time of manufacture and is permanently attached.</p> <p>This inspection does not apply to integral bars that form part of the body work providing the requirements of section 49 Exterior Projections of Cabs are met.</p>	<ol style="list-style-type: none">1. The Frontal Protection System must display a genuine permanently attached 'e' mark that would be applied at the time of manufacture

Record of Revision

Revision	Date	Description of Change
1	18/04/2011	Version 1
2	11/03/2013	Revise Note 1
3	03/04/18	Remove numbering from note.
4	01/09/2020	Clarify Application and MOI.

69 Electrical Safety

Application: All Vehicles equipped with one or more traction motor(s) operated by electric power

Method of Inspection	Required Standard
<p>This section should be read in conjunction with the required standards set out in General Construction.</p> <p>See Glossary for definition of Hybrid Electric Vehicle.</p> <p>Ensure the vehicle or system as presented is accompanied by satisfactory evidence in the form of:</p> <p>Original mass produced vehicle approval to UNECE R100.01, or</p> <ul style="list-style-type: none"> • A test report to UNECE R100.01 witnessed by the Approval Authority (VCA) or Authorised Technical Service • Model Report created by Customer Service Centre, Ellipse Swansea (CSC) <p>and in these cases, a Visual Inspection is required.</p> <p>In the case of an unmodified mass-produced vehicle holding an approval to UNECE R100.01 and above, the standards in this section shall be considered to be met, however where evidence suggests that the vehicle has been modified, the Examiner shall assess whether the modification would be likely to materially affect the performance of the relevant component or system, and if so, carry out an assessment against the RS.</p> <p>Note 1: A vehicle with batteries of a maximum voltage of 48 volts need only comply with the essential technical requirements of ECE R100.00</p> <p>Note 2: The use of stretchy or soft coverings over high voltage terminals is strictly forbidden.</p>	<ol style="list-style-type: none"> 1. The vehicle as presented must be accompanied by satisfactory documentary evidence of compliance with the required standard for electric/hybrid vehicles (see Note 1). <p>Visual Inspection</p> <ol style="list-style-type: none"> 2. All high voltage cable terminations must be suitably protected, these protections (solid insulator, barrier, enclosure, etc.) shall not be able to be opened, disassembled or removed without the use of tools (see Note 2). 3. Any enclosure carrying high voltage shall be clearly marked with an indelible label (see Figure 1) affixed in a visible location. 4. All visible high voltage cables must be orange in colour. 5. All metal enclosures with internal high voltage must have an earth path for protection against electrical shock (this may be a separate bonding or the mounting arrangement where it does not isolate the enclosure)

Method of Inspection	Required Standard
<p data-bbox="161 209 280 240">Figure 1</p> 	

Record of Revision

Revision	Date	Description of Change
1	05/10/2015	New Section
2	03/04/18	'For Information Only' added to title. New Note 1 with link from RS1, renumber following note and link from RS2.
3	01/07/2018	Section now live
4	01/04/2022	Section renamed to match RV(A)R 2020, application clarified, reference to glossary added to MOI.
5	22/05/2023	Removal of RS3 & re-numbering of remaining RS. TSE IVA N1 069 001
6	09/10/2024	Add detail to MOI to confirm requirements for unmodified mass produced vehicles (TSE IVA N1 69 002).

This page intentionally left blank

General Construction

Application: All Vehicles subject to IVA requirements except new unmodified mass produced vehicles

Method of Inspection	Required Standard
<p>The following section assesses the vehicles suitability for use under all normal operating conditions, including when it is laden to its maximum permitted axle/gross vehicle weight and considers the effects of vibrations and the forces imposed by its design speed, acceleration characteristics, braking and cornering. The vehicle must at all times present no danger to the occupants or other road users.</p> <p>Note 1: A television monitor which can be seen from the driving position and capable of operation when the vehicle is in motion is not acceptable, unless it provides visibility to the rear of the vehicle, a navigation map, vehicle specific information or a combination of these items.</p> <p>Note 2 This assessment includes the attachment of any component/assembly of any structure, the strength and suitability of materials used, (including pipes etc), all fastenings, (welding, brazing, bonding, rivets, nuts, and bolts etc) are to be assessed for suitability, completeness, and security.</p> <p>Note 3 When assessing a component for leaks the original design of the component will be taken into consideration.</p> <p>Note 4: This does not apply to control leads (fly leads) used on specialised equipment i.e., power ramps and lifts.</p>	<ol style="list-style-type: none"> 1. All aspects of the design and construction of the vehicle must be such that no immediate danger is caused or likely to be caused to any person in the vehicle or to other road users (see Note 1). 2. All aperture covers (other than doors), including tailgates, boot and bonnet lids must be capable of being latched securely in the fully closed position. 3. When driven, the safe control of the vehicle must not be impaired or likely to be impaired, due to a design or construction feature of characteristic. 4. The vehicle structure and all components including their attachment must be suitable and of adequate strength (see Note 2). 5. A transmission/braking component which rotates during vehicle operation, electrical component, steering or suspension component, wheel or tyre must not foul on another component, or be likely to foul under normal operating conditions. 6. Fuel and electrical components must not be subject to either a corrosive environment or be exposed to heat sources likely to cause premature failure. 7. All steering, suspension, brake, and fuel system components must not be leaking (see Note 3). 8. All electrical cables/wires must be free from chafing and secured at intervals of at least every 300mm unless contained in a secure hollow component (see Note 4).

General Construction

Method of Inspection	Required Standard
	<p data-bbox="1025 231 2042 300">9. All electrical components must be secure, be of adequate capacity, and be insulated as required as to prevent short circuiting during operation.</p>

Record of Revision

Revision	Date	Description of Change
1	18/04/2011	Version 1
2	05/10/2015	RS 8 linked to Note 4
3	22/05/2023	Revise grammar in RS 9.

This page intentionally left blank

Normal IVA Requirements

Where a vehicle is subject to Normal IVA, all the Basic subjects are tested except those where documentary evidence is required or has been provided. Where compliance with the Comparable standards is demonstrated, there is no need to test the vehicle in that subject other than to verify the vehicle has not been adapted or modified so that the evidence is in question.

In relation to the Normal IVA Inspection the examiner must be satisfied that the documentary evidence provided relates to the vehicle in its **presented** condition. Modifications should be judged as to their effect on the documentary evidence or if they have been made in order to ensure compliance.

Record of Revision

Revision	Date	Description of Change
1	18/04/2011	Version 1

01 Noise

Application: Vehicles subject to Normal requirements

Method of Inspection	Required Standard
<p>Ensure the vehicle as presented is accompanied by satisfactory evidence to the required standard.</p> <p>Conversions that are not based on N1 vehicles may comply with the applicable requirements of the original base vehicle. Documentary evidence of base or incomplete vehicle approvals will be deemed acceptable.</p> <p>Note 1: Manufacturers drain holes are permitted in silencers.</p> <p>Note 2: Where evidence of compliance has been provided, subsequent modification to the exhaust system will be permitted providing</p> <ul style="list-style-type: none"> a. it is downstream of any emissions control device (e.g., catalyst), and b. the emission control device and silencer are identical to that fitted at the time of compliance was demonstrated. <p>Note 3: Different silencers may be fitted downstream of the emissions control device. However, further evidence of compliance will be required for the vehicle in its modified condition. This may be provided in the form of a test report comprising of a stationary comparison test of the vehicle fitted with the original silencer and the alternative silencer.</p> <p>The exhaust may have several outlets up to 300mm apart connected to the same silencer. In this instance the microphone must face the outlet closest to the vehicle contour or highest from the ground. In all other cases, separate measurements must be taken for each exhaust outlet; the highest value obtained is the test value.</p> <p>The noise emitted from the exhaust system will be measured if:</p>	<ul style="list-style-type: none"> 1. The vehicle as presented must be accompanied by satisfactory evidence of compliance with the required standard for “noise” with No un-permitted modifications to the exhaust system which would invalidate the evidence (see Notes 2 and 3). 2. The exhaust system must be securely mounted. 3. Exhaust system components must be secure. 4. The exhaust system must be free from leaks (see Note 1). <p>Where applicable:</p> <ul style="list-style-type: none"> 5. A vehicle with permitted modifications must be accompanied by a stationary noise test report 6. The measured sound level must be no more than 2 dB above the evidence supplied.

Method of Inspection	Required Standard
<p> a. the model report is a 'Version 1' report or b. the examiner is not satisfied that the vehicle or noise emitted is as specified in the report or c. the vehicle exhaust system has been modified as permitted (when judged against the evidence provided), and the evidence supplied includes a sound level reading from a "stationary" noise test. </p> <p>Using sound level meter to the manufacturer's instructions, carry out a stationary noise check.</p> <p>Place the vehicle within the authorised test area. With the sound meter horizontal, set the microphone height so that it is at the height of the exhaust outlet or 200mm from the ground, whichever is higher at an angle of 45 degrees to the exhaust outlet in the direction which gives the greatest distance between it and the vehicle contour at a distance of 500mm from the exhaust outlet.</p> <p>With the vehicle at normal operating temperature, run the engine to replicate the original rpm as listed on the report,</p> <p>The measured sound level will be deemed acceptable if the average of three readings is no more than 2dbA above the evidence supplied.</p>	

Record of Revision

Revision	Date	Description of Change
1	18/04/2011	Version 1
2	03/04/2018	Link RS1 to Notes 2 & 3, RS4 to Note 1 and remove numbering from Note 4 (align with M1 IM).

This page intentionally left blank

02 Emissions

Application: Vehicles subject to Normal requirements

Method of Inspection	Required Standard																				
<p>Ensure the vehicle as presented is accompanied by satisfactory evidence to the required standard for either Light Duty or Heavy Duty Emissions.</p> <p>Conversions that are not based on N1 vehicles may comply with the applicable requirements of the original base vehicle. Documentary evidence of base or incomplete vehicle approvals will be deemed acceptable.</p> <p>Vehicles are not required to have On Board Diagnostics</p> <p>Where evidence of compliance has been provided, subsequent modification to the exhaust system will be permitted providing</p> <ul style="list-style-type: none"> • it relates to the exhaust system length after the last silencer; and • the emissions control device is identical to that fitted before the modification. <p>In the case of Armoured vehicles exemption from any requirement of this section is permitted if it can be demonstrated to the satisfaction of the Approval Authority that it is impossible for the vehicle to comply due to its special purpose.</p>	<p>1. The vehicle as presented must be accompanied by satisfactory evidence of compliance with the required standard for 'Emissions'. (See Tables 1 & 2).</p> <p>Table 1</p> <table border="1" style="width: 100%; border-collapse: collapse; margin-bottom: 10px;"> <thead> <tr> <th colspan="4" style="text-align: center;">Heavy Duty Emissions</th> </tr> <tr> <th style="width: 30%;">Manufactured Date</th> <th style="width: 20%;">Directive/Reg Requirement</th> <th style="width: 20%;">As amended by</th> <th style="width: 30%;"></th> </tr> </thead> <tbody> <tr> <td style="text-align: center;">Vehicles, before 1st October 2009</td> <td style="text-align: center;">88/77/EEC</td> <td style="text-align: center;">99/96/EC</td> <td style="text-align: center;">Row B1 Limits apply (Euro IV)</td> </tr> <tr> <td style="text-align: center;">Vehicles, on or after 1st October 2009</td> <td style="text-align: center;">88/77/EEC</td> <td style="text-align: center;">99/96/EC</td> <td style="text-align: center;">Row B2 Limits apply (Euro V)</td> </tr> <tr> <td style="text-align: center;">Complete or completed vehicles, on or after 1st September 2018</td> <td style="text-align: center;">Reg (EC) 595/2009</td> <td></td> <td style="text-align: center;">Annex I limit values apply (Euro VI)</td> </tr> </tbody> </table> <p>2. The exhaust must not emit excessive smoke or vapour of any colour to an extent likely to obscure the vision of other road users.</p>	Heavy Duty Emissions				Manufactured Date	Directive/Reg Requirement	As amended by		Vehicles, before 1 st October 2009	88/77/EEC	99/96/EC	Row B1 Limits apply (Euro IV)	Vehicles, on or after 1 st October 2009	88/77/EEC	99/96/EC	Row B2 Limits apply (Euro V)	Complete or completed vehicles, on or after 1 st September 2018	Reg (EC) 595/2009		Annex I limit values apply (Euro VI)
Heavy Duty Emissions																					
Manufactured Date	Directive/Reg Requirement	As amended by																			
Vehicles, before 1 st October 2009	88/77/EEC	99/96/EC	Row B1 Limits apply (Euro IV)																		
Vehicles, on or after 1 st October 2009	88/77/EEC	99/96/EC	Row B2 Limits apply (Euro V)																		
Complete or completed vehicles, on or after 1 st September 2018	Reg (EC) 595/2009		Annex I limit values apply (Euro VI)																		

Table 2

Section In Manual	Date of Vehicle Manufacture	European Standard (EC or ECE equivalent)	Comparable Non-European Standards				Notes
			United States	Canada	Japan	Australia	
Exhaust Emissions (Euro 5)	01/01/2012 (Category M1)	Regulation EC 715/2007 (as amended by EC 692/2008), Annex 1, Table 1. On-Board Diagnostic systems are not required				ADR 79/03 & 79/04 (Petrol & Diesel)	<p>“Reference Mass” has the same meaning as in Directive 70/220/EEC as amended by Directive 96/69.</p> <p>“Class I vehicle” means a goods vehicle (N1) which has a reference mass not exceeding 1305kg.</p>
Exhaust Emissions (Euro 6)	01/09/2016 (Category M1)	Regulation EC 715/2007 as amended by EC 692/2008, Annex 1, Table 2, On-Board Diagnostic systems are not required					<p>“Class II vehicle” means a goods vehicle (N1) which has a reference mass exceeding 1305kg but not exceeding 1760kg.</p> <p>“Class III vehicle” means a goods vehicle which has a reference mass exceeding 1760kg.</p>
Exhaust Emissions (Euro 6 updated)	01/12/2018 (Category M1)	Regulation (EU) No. 2017/1151 Annex XXI On-Board Diagnostic systems are not required					<p>“Diesel passenger vehicle” means a vehicle of category M1 the maximum mass of which exceeds 2000kg, fitted with a compression ignition engine, and which is:</p> <ul style="list-style-type: none"> • constructed or adapted to carry more than 6 occupants inc. the driver, or • an off road vehicle as defined in Annex II to the 2007 Directive.

Record of Revision

Revision	Date	Description of Change
1	18/04/2011	Version 1
2	31/10/2011	Add Euro 5 and Euro 6 Requirements.
3	31/05/2012	Insert table after RS1 and update Table 2
4	03/04/18	Update acceptable ADR levels.
5	01/07/2018	Update standards applicable from 01Sep 18 (heavy duty emissions) and 01 Dec 19 (light duty emissions).
6	09/10/2024	Table 2 revised.

This page intentionally left blank

09 Braking

Application: Vehicles subject to Normal requirements

Method of Inspection	Required Standard
<p>Ensure the vehicle as presented is accompanied by satisfactory evidence to the required standard.</p> <p>Conversions that are not based on N1 vehicles may comply with the applicable requirements of the original base vehicle. Documentary evidence of base or incomplete vehicle approvals will be deemed acceptable provided the maximum mass of the original approvals has not been exceeded. Approval evidence is not invalidated by repositioning brake cables or pipework.</p>	<ol style="list-style-type: none">1. The vehicle as presented must be accompanied by satisfactory evidence of compliance with the required standard for Braking.

Record of Revision

Revision	Date	Description of Change
1	18/04/2011	Version 1
2	01/07/2018	Update MOI in line with RV(A)R requirements.
3	01/04/2022	Final paragraph of MOI removed.

13A Anti – Theft / Immobiliser

Application: Vehicles subject to Normal requirements

Method of Inspection	Required Standard
<p>An immobiliser is an electronic device intended to prevent the driving away of a vehicle powered by its own engine.</p> <p>Ensure that the vehicle as presented is accompanied by documentary evidence of compliance for a category 1 or 2 installation.</p> <p>Conversions that are not based on N1 vehicles do not need to comply if there was no theft / immobiliser requirement for the base vehicle.</p> <p>Note 1: A “Category 2” installation refers to an immobiliser only. A “Category 1” installation refers to an immobiliser and an alarm.</p> <p>Evidence of compliance can be one of the following:</p> <ul style="list-style-type: none"> • Documentary evidence from a test laboratory • Documentary evidence from the vehicle manufacturer (in the case of a mass produced vehicle) • An original certificate of installation from a Mobile Electronics and Security Federation (MESF) accredited installer 	<ol style="list-style-type: none"> 1. The vehicle as presented must be accompanied by evidence of compliance for an Immobiliser.

Record of Revision

Revision	Date	Description of Change
1	18/04/2011	Version 1
2	31/05/2012	Removed VSIB from the list of acceptable evidence add acceptance of Thatcham Recognised installer
3	01/09/2020	Remove acceptance of Thatcham Recognised Installer.

13B Anti – Theft / Alarm

Application: Vehicles subject to Normal requirements (optional fitment)

Method of Inspection	Required Standard
<p>Ensure that any Alarm and optional Panic Alarm which does not form part of the vehicle alarm system is accompanied by satisfactory documentary evidence of compliance.</p> <p>Conversions that are not based on N1 vehicles do not need to comply if there was no theft / alarm requirement for the base vehicle.</p> <p>Note 1: A “Category 1” installation refers to an immobiliser and an alarm.</p> <p>Note 2: Panic Alarm means a device which enables a person to use an alarm, installed on the vehicle, to summon assistance in an emergency.</p> <p>Evidence of compliance can be one of the following:</p> <ul style="list-style-type: none"> • Documentary evidence from a test laboratory • Documentary evidence from the vehicle manufacturer (in the case of a mass produced vehicle) • An original certificate of installation from a Mobile Electronics and Security Federation (MESF) accredited installer 	<ol style="list-style-type: none"> 1. The vehicle as presented must be accompanied by evidence of compliance where an alarm is fitted. 2. The vehicle as presented must be accompanied by evidence of compliance where a panic alarm is fitted.

Record of Revision

Revision	Date	Description of Change
1	18/04/2011	Version 1
2	31/10/2011	Removed VSIB from the list of acceptable evidence add acceptance of Thatcham Recognised installer
3	01/09/2020	Remove acceptance of Thatcham Recognised Installer.

14 Protective Steering

Application: Vehicles subject to Normal requirements

Method of Inspection	Required Standard
<p>Ensure the vehicle as presented is accompanied by satisfactory evidence to the required standard.</p> <p>Note 1: This item does not apply in the case of vehicles:</p> <ul style="list-style-type: none"> a. complying with the Frontal Impact requirements b. with a maximum permissible mass exceeding 1500kg <p>(usually M1 derived vehicles)</p> <p>The requirements according to the category of the base or incomplete vehicle based on maximum mass may apply.</p>	<p>1. The vehicle as presented must be accompanied by satisfactory evidence of compliance with the required standard for 'Protective Steering' (See Note 1).</p>

Record of Revision

Revision	Date	Description of Change
1	18/04/2011	Version 1
2	31/10/2011	Add Note 1 to Mol and reference to Note 1 in RS1

19 Seat Belt Anchorages

Application: Vehicles subject to Normal requirements

Method of Inspection	Required Standard
<p>Ensure the vehicle as presented is accompanied by satisfactory evidence to the required standard.</p> <p>Seating positions in vehicles that are for use when the vehicle is stationary do not need to comply with anchorage requirements. Seats that are for use only when stationary must be identified by means of a pictogram or a sign with appropriate text.</p> <p>The IVA seat belt anchorage compliance and installation declarations (Forms 19a & 19b) are now available online at https://www.gov.uk/government/publications/iva-declaration-form-for-seat-belt-anchorage-compliance-iva-19a-and-19b</p>	<ol style="list-style-type: none"> 1. The vehicle as presented must be accompanied by satisfactory evidence of compliance with the required standard for 'Seat Belt Anchorages'.

Record of Revision

Revision	Date	Description of Change
1	18/04/2011	Version 1
2	31/10/2011	Remove annexes – now available online
3	05/10/2015	Update hyperlink to IVA 19a & 19b

39 Fuel Consumption / CO₂ Emissions

Application: Vehicles subject to Normal requirements (Vehicles approved to Heavy Duty Emissions are exempt)

Method of Inspection	Required Standard
<p>Ensure the vehicle as presented is accompanied by satisfactory evidence to the required standard</p> <p>Does not apply where the applicant accepts a CO₂ figure determined by the Secretary of State.</p> <p>Subsequent modification of the exhaust system is permitted providing:</p> <ul style="list-style-type: none"> • it is downstream of any emissions control device • the emissions control device is identical to that fitted before the modification. 	<ol style="list-style-type: none"> 1. The vehicle as presented must be accompanied by satisfactory evidence of compliance with the required standard for 'Fuel Consumption/CO₂'.

54 Side Impact

Application: Vehicles subject to Normal requirements with an effective date from October 2003 and a seat reference point no greater than 700mm from the ground

Method of Inspection	Required Standard
<p>Ensure the vehicle as presented is accompanied by satisfactory evidence to the required standard.</p> <p>Conversions that are not based on N1 vehicles may comply with the applicable requirements of the original base vehicle. Documentary evidence of base or incomplete vehicle approvals will be deemed acceptable provided the maximum mass of the original approvals has not been exceeded.</p>	<ol style="list-style-type: none">1. The vehicle as presented must be accompanied by satisfactory evidence of compliance with the required standard for 'Side Impact'.

Record of Revision

Revision	Date	Description of Change
1	18/04/2011	Version 1

62 Hydrogen Powered Motor Vehicles

Application: All vehicles powered by Hydrogen

For the information of applicants only

For the required standards for hydrogen fuelled vehicles please refer to Section 03A.

Hydrogen powered vehicles can be either internal combustion engine, with hydrogen fuel burnt in a similar way to petrol, or they can be hydrogen fuel cell, where hydrogen is converted to electricity in a chemical reaction, and the electricity powers the vehicle via an electric motor. The hydrogen can be stored (under high pressure) in compressed gas or liquefied form.

Method of Inspection

Confirm that the vehicle is a Hydrogen powered vehicle, by noting the presence of a Hydrogen fuel tank, and in the case of hydrogen fuel cell vehicle, the fuel cell and electric motor.

Record of Revision

Revision	Date	Description of Change
1	11/03/2013	
2	01/09/2020	Clarify location of requirements

69 Electrical Safety

Application: Vehicles equipped with one or more traction motor(s) operated by electric power subject to Normal requirements

Method of Inspection	Required Standard
<p>This section should be read in conjunction with the required standards set out in General Construction. See Glossary for definition of Hybrid Electric Vehicle. Ensure the vehicle or system as presented is accompanied by satisfactory evidence in the form of:</p> <p>Original mass produced vehicle approval to UNECE R100.01 or</p> <ul style="list-style-type: none"> • A test report to UNECE R100.01 witnessed by the Approval Authority (VCA) or Authorised Technical Service <p>or</p> <ul style="list-style-type: none"> • Model Report created by Customer Service Centre, Ellipse Swansea (CSC) <p>and in these cases, a Visual Inspection is required</p> <p>Note 1: The use of stretchy or soft coverings over high voltage terminals is strictly forbidden.</p> <p>Figure 1</p> <div style="display: flex; justify-content: space-around; align-items: center;">  </div>	<ol style="list-style-type: none"> 1. The vehicle as presented must be accompanied by satisfactory documentary evidence of compliance with the required standard for electric vehicles. <p>Visual Inspection</p> <ol style="list-style-type: none"> 2. All high voltage cable terminations must be suitably protected, these protections (solid insulator, barrier, enclosure, etc.) shall not be able to be opened, disassembled or removed without the use of tools (see Note 1). 3. Any enclosure carrying high voltage shall be clearly marked with an indelible label (see Figure 1) affixed in a visible location. 4. All visible high voltage cables must be orange in colour. 5. All metal enclosures with internal high voltage must have an earth path for protection against electrical shock (this may be a separate bonding or the mounting arrangement where it does not isolate the enclosure).

Record of Revision

Revision	Date	Description of Change
1	01/07/2018	New Section
2	01/04/2022	Section renamed to match RV(A)R 2020, application clarified, reference to glossary added to MOI.
3	22/05/2023	Removal of RS3 & re-numbering of remaining RS. TSE IVA N1 069 001
4	09/10/2024	Add detail to MOI to confirm requirements for unmodified mass produced vehicles (TSE IVA N1 69 002).

Glossary of Terms

Air Bag

A flexible bag fitted to a vehicle designed to be filled with gas under pressure in order to protect the driver or front seat passenger in the event of a collision involving the front of the vehicle.

Blunted Edge

An edge not likely to cause injury whatever the circumstances under finger/thumb pressure contact is not likely to puncture the skin.

Brake Efficiency

Maximum total brake force expressed as a percentage of maximum gross weight.

CNG

Compressed Natural Gas

Convertible Car

A vehicle where, in certain configurations, there is no rigid part of the vehicle body above the belt line with the exception of the front roof supports and/or the roll-over bars and/or the seat belt anchorage points.

Date of Manufacture

In the case of an Amateur Built Vehicle is, unless otherwise stated in the regulations or Inspection Manual:

- a. the date on which the vehicle is presented for examination; or
- b. a date prior to the date the vehicle is presented for examination if there is conclusive evidence the vehicle was completed and included all the parts which it needs to comply with the prescribed requirements and was in such a condition as to be acceptable to test on that date.

Designated Seating Position

A position where there is a seat designated for normal use while the vehicle is travelling on the road.

Emergency Vehicle

An **emergency vehicle** is any vehicle that is designated and authorized to respond to an emergency in a life-threatening situation. These vehicles are usually operated by designated agencies, often part of the government, but also run by charities, non-governmental organisations and some commercial companies. The following are permitted to use blue lights according to RVLRL and its amendments: For police purposes, for firefighting purposes, for ambulance purposes, for bomb disposal, for nuclear accidents, for mountain rescue, for mine rescue, by the RAF Armament Support Unit, by the

Glossary of Terms

National Blood Service, by HM Coastguard, by the RNLI for launching lifeboats, by HM Revenue and Customs for serious crime and by the military special forces for a national security emergency.

Extreme Outer Edge

In relation to the side of a vehicle, the vertical plane parallel with the longitudinal axis of the vehicle and coinciding with its lateral outer edge, disregard the protection of:

- distortion of any tyre due to the weight of the vehicle
- connections for tyre pressure gauges
- anti-skid devices mounted on the wheels
- rear view mirrors
- lamps and reflectors
- custom seals and devices for securing and protecting such seals
- special equipment
- in respect of Section 16 (Exterior Projections) only: windows, handles, hinges, push buttons and fuel tank filler caps.

Gullwing door

A door that hinges from top of the door aperture.

Hard Parts

Parts made of a material of hardness exceeding 60 shore.

Harness Belt

Means an adult belt which is a harness belt comprising a lap belt and shoulder straps.

Hybrid Electric Vehicle (HEV)

A vehicle, including vehicles which draw energy from a consumable fuel only for the purpose of recharging the electrical energy/power storage device that for the purpose of mechanical propulsion draws energy from both of the following on-vehicle sources of stored energy/power:

- (a) A consumable fuel;
- (b) A battery, capacitor, flywheel/generator, or other electrical energy/power storage device.

Ignition Switch

A key operated switch normally used to start the engine.

In Running Order

In relation to the vehicle weight, means all fluids (such as oils and engine coolant) necessary for the vehicle to be driven, a full fuel tank, a spare wheel and tool kit carrying a driver of 75kg but no other passengers or load.

Insecure

A component or its fixing is, due to its design or a construction feature, not completely attached to the vehicle structure or to another associated component as intended.

Kerbside Weight

For the purpose of this manual only:

The weight of the vehicle with no driver or passengers, a full fuel tank, an adequate supply of the necessary oils, water, fluids etc and no load other than tools and equipment normally carried.

Lambda

The ratio by mass of air to petrol vapour in the mixture entering the combustion chamber, divided by 14.7.

Lap Belt

A seat belt which passes across the front of the wearer's pelvic region, and which is designed for use by an adult.

Lateral Brake Distribution

In relation to an axle, means the ratio (expressed as a percentage) of the lower to the higher of the braking forces transmitted by the tyres to the road surface for two wheels, on opposite sides of the vehicle on the same axle.

Longitudinal Plane

A vertical plane parallel to the longitudinal axis of the vehicle.

LPG

Liquefied Petroleum Gas.

Major Manufacturer

A vehicle manufacturer that produces vehicles approved to EC Whole Vehicle Type Approval standards.

Manufacturer's Plate

A piece of durable material e.g., metal or plastic that is likely to last the life of the vehicle and which is permanently marked with the required markings.

Glossary of Terms

Mass in running order

The mass of the vehicle, with its fuel tank(s) filled to at least 90 % of its or their capacity/capacities. Includes the mass of the driver (75 kg), other liquids, standard equipment fitted in accordance with the manufacturer's specifications and, when they are fitted, the mass of the bodywork, the cabin, the coupling, and the spare wheel(s) as well as tools.

Mass produced Vehicle

For the purpose of this manual only:

A vehicle as originally manufactured in numbers greater than 300 that has been subject to no more than minor modification or alteration since manufacture, that is produced by a recognised **Major Manufacturer** such that the vehicle referred to would be of a type expected to be seen by the public in a showroom supported by a major world renown manufacturer, i.e.: It would meet the 'reasonable test'.

Matched Pair

For the purpose of this manual only:

Lamps fitted to the vehicle must be of the same brightness, intensity, colour, shape, height, position, and beam pattern.

Motor Vehicle

Any power driven vehicle designed and constructed for use on a road which is moved by its own means, has at least four wheels, has a maximum design speed exceeding 25 kilometres per hour and is an incomplete, complete, or completed vehicle.

Off-road Vehicle (EU 858/2018)

N1 vehicles shall be subcategorised as off-road vehicles (N1G) if they satisfy at the same time the following conditions:

- (a) at least one front and at least one rear axle designed to be driven simultaneously irrespective of whether one powered axle can be disengaged;
- (b) at least one differential locking mechanism or a mechanism having similar effect is fitted;
- (c) they are able to climb at least a 25 % gradient as a solo vehicle;
- (d) they satisfy five out of the following six requirements:
 - (i) the approach angle shall be at least 25 degrees;
 - (ii) the departure angle shall be at least 20 degrees;
 - (iii) the ramp angle shall be at least 20 degrees;
 - (iv) the ground clearance under the front axle shall be at least 180 mm;
 - (v) the ground clearance under the rear axle shall be at least 180 mm;
 - (vi) the ground clearance between the axles shall be at least 200 mm.

Orientation

For the purpose of this manual only:

Headlamps require to be fitted as they are intended i.e., Top to Top etc. Some lamps are fitted at other angles to combat the cut off requirement for headlamp aim.

Glossary of Terms

Power Braking

A system that requires the use of stored energy to operate.

Production Vehicle

A vehicle of a make, model and type mass produced by the vehicle manufacturer.

Radius

Refers to the external radius of curvature.

Reciprocally incorporated lamps

Devices having separate light sources or a single light source operating under different conditions (for example, optical, mechanical, electrical differences), totally or partially common apparent surfaces in the direction of the reference axis and a common lamp body.

Rotary Engine

An engine in which the torque is provided by means of one or more rotors and not by any reciprocating pistons and which is deemed to be a four stroke engine.

Seat Displacement Device

A device to permit forward tipping of a seat or the back rest to fold down.

Servo Assisted

A system where the muscular energy of the driver is supplemented by another energy source.

Suicide Door

A door that hinges from the rear of the door aperture.

Temporary-use spare tyre

Means a tyre different from a tyre intended to be fitted to any vehicle for normal driving conditions; but intended only for temporary use under restricted driving condition.

Vehicle

A motor vehicle or a trailer.

Record of Revision

Revision	Date	Description of Change
1	18/04/2011	Version 1
2	31/05/2012	Insert definition of Reciprocally Incorporated Lamps
3	03/04/18	Correct definition of 'Hard Parts'.
4	01/07/2018	Add definition of mass in running order.
5	01/09/2020	Add definitions of Motor Vehicle, Vehicle and Emergency vehicle.
6	01/04/2022	Definition of Hybrid Electric Vehicle and Off-Road Vehicle added.



Driver & Vehicle
Standards
Agency

Contact us

DVSA
Berkeley House
Croydon Street
Bristol
BS5 0DA

www.gov.uk/dvsa

Telephone

0300 123 9000

[Find out about call charges](#)

Monday to Friday - 7.30am until 6.00pm (normal working hours)