



Defence
Safety
Authority

Manual of Military Air System Certification (MMAC)

Military Aviation
Authority

Foreword

1. The purpose of this Manual of Military Air System Certification (MMAC) is to provide Guidance ► **Material** ◀ to those organizations required to manage Air System Type Design in accordance with (iaw) the MAA's 5810 and 5820 Regulatory Articles (RAs).
2. ► **In accordance with MAA01¹**, ◀ the techniques and processes in this Manual ► **describe the MAA's view of good practice for Type Certification. They** ◀ have evolved since the creation of the MAA in 2011 and have been informed by best practice from civil aerospace. Further, this single Manual brings together information formerly contained within the Guidance from the MAA's 5810 and 5820 RAs and information published previously in numerous MAA Regulatory Notices (RN) and Defence Standards. As a result, this Manual now presents a single, comprehensive resource to all aspects of Military Air System Certification and is thus an excellent source of guidance to RAs 5810 and 5820. However, the nature of Air System procurement means that no single approach will suit every application; thus, effective and efficient Certification requires Type Airworthiness Authorities (TAA) to act on an informed understanding of the myriad routes to Certification available to them. Accordingly, MAA Certification Division and the Defence Equipment and Support Airworthiness Team remain a key source of assistance and guidance.
3. The MMAC is purposely structured so that the early chapters provide the context and generic guidance, before moving to more in-depth guidance regarding specific routes to Certification. Accordingly, the MMAC chapters are as follows:
 - a. [Chapter 1](#) provides the context and background.
 - b. [Chapter 2](#) provides guidance for the Certification of Air System Type Designs and explains the Military Air System Certification Process (MACP) (supporting RA 5810 - Military Type Certification (MRP Part 21 Subpart B)).
 - c. [Chapter 3](#) provides guidance for changes to Air System Type Designs (supporting RA 5820 - Changes in Type Design (MRP Part 21 Subpart D)).
 - d. [Chapter 4](#) explains the reason for, and differences between, Military Type Certificates (MTC) and Approved Design Change Certificates (ADCC).
 - e. [Chapter 5](#) explains how credit can be claimed during the Certification of an Air System by leveraging Assurance from another Accepted Certification Authority and / or against an alternative Certification Specification (replacing MAA/RN/2016/11² and 2019/02³) ► **and supporting the MAA Manual of Military Airworthiness Recognition (MMAR)⁴**. ◀
 - f. [Chapter 6](#) provides details regarding the evolution of Defence Standard (Def Stan) 00-970, the subsequent Transformation activity and provides detailed guidance for use.
 - g. [Chapter 7](#) explains why the use of novel technology needs to be carefully considered during a Certification ► **project** ◀ and provides details on some specific technologies that are deemed novel by the MAA.

¹ ► Refer to [MAA01 - Military Aviation Authority Regulatory Principles](#). ◀

² MAA/RN/2016/11 – Use of existing Certification evidence as credit towards demonstrating compliance with the military Air Systems Certification process.

³ MAA/RN/2019/02 – Comparison of Defence Standard 00-970 with Alternative Airworthiness Codes.

⁴ ► Refer to [MMAR](#). ◀

CONTENTS**FOREWORD 2**

CONTENTS	3
CHAPTER 1: INTRODUCTION	5
CROSS-REFERENCES	5
CONTEXT.....	5
SCOPE	6
DEFINITIONS	6
CHAPTER 2: CERTIFICATION OF AIR SYSTEM TYPE DESIGNS (MRP PART 21 SUBPART B) AND THE MILITARY AIR SYSTEM CERTIFICATION PROCESS (MACP).....	15
INTRODUCTION.....	15
MACP.....	17
ANNEX A TO CHAPTER 2.....	30
CHAPTER 3: CHANGES IN TYPE DESIGN (MRP PART 21 SUBPART D)	34
INTRODUCTION.....	34
CLASSIFICATION OF CHANGE	34
APPLICATION FOR CHANGE IN TYPE DESIGN	39
DESIGNATION OF APPLICABLE CERTIFICATION SPECIFICATIONS	39
APPROVAL OF MAJOR CHANGES	42
ANNEX A.....	45
CHAPTER 4: MTC AND ADCC EXPLAINED.....	59
INTRODUCTION.....	59
MAA CERTIFICATION.....	59
MANAGEMENT OF CERTIFICATES.....	62
CHAPTER 5: CERTIFICATION CREDIT WITHIN THE MACP	65
INTRODUCTION.....	65
ALTERNATIVE CERTIFICATION SPECIFICATIONS	75
CHAPTER 6: DEFENCE STANDARD 00-970.....	77
INTRODUCTION.....	77
TRANSFORMATION	78
OUTCOME.....	78
USING DEF STAN 00-970	80
CHAPTER 7: NOVEL TECHNOLOGIES.....	86
INTRODUCTION.....	86
ADDITIVE MANUFACTURE.....	86
MULTI-CORE PROCESSOR (MCP)	91

LIST OF TABLES

Table 1 – Glossary of Certification-Specific terms	6
Table 2 – Indicative (Minimum) MACP Planning Timescales	16
Table 3 – Means of Compliance Codes	23
Table 4 – Examples of Substantial, Significant and Not Significant Changes	48
Table 5 – Routes to Certification	65
Table 6 – CRE Assessment Tool (Example Considerations).....	71
Table 7 – Defence Standard 00-970 Parts	80
Table 8 – Defence Standard 00-970 Format	82
Table 9 – Example Transformed Defence Standard 00-970 – Part 1 (Combat FW)	83

LIST OF FIGURES

Figure 1 – MACP 6-Phase Approach	15
Figure 2 – MACP Phase within the CADMID Cycle.....	15
Figure 3 – MACP Flow Diagram.....	16
Figure 4 – Establishing a TCB for a new and changed Type Design	20
Figure 5 – Compliance Flowchart.....	26
Figure 6 – Major Change - MTC vs ADCC	34
Figure 7 – Change Classification Process.....	37
Figure 8 – Establishing the TCB for a Changed Product	41
Figure 9 – Design Change and Assurance Level	43
Figure 10 – Comparison of Legacy to non-Legacy Air System Certification	59
Figure 11 – MAA MTC and ADCC Examples	61
Figure 12 – Civil TC and TCDS Examples	61
Figure 13 – Part A/B: Previous vs Revised Approach	68
Figure 14 – Configuration and Usage (Role & Environment).....	71
Figure 15 – Establishing the iTCB.....	74
Figure 16 – Air System TCB Benchmarking	75
Figure 17 – Def Stan 00-970 Genesis	77
Figure 18 – Def Stan 00-970 Evolution (shaded area represents the current situation)	77
Figure 19 – Defence Standard 00-970 Transformation Methodology	79
Figure 20 – Structure of Def Stan 00-970.....	81
Figure 21 – AM Processes: Power Bed Fusion (left) & Material Extrusion (right)	86
Figure 22 – Component Optimization.....	87
Figure 23 – Multicore Interference	91
Figure 24 – WCET vs Task	92

Chapter 1: Introduction

Cross-references

1. This Manual must be read in conjunction with the following Regulations, standards and papers:

a. **Standards**

[Def Stan 00-970](#) – Certification Specifications for Airworthiness.

b. **Regulatory Article (RA)**

[RA 1015](#) Type Airworthiness Management – Roles and Responsibilities.

[RA 5810](#) Military Type Certificate (MRP Part 21 Subpart B).

▶ [RA 5812](#) Digital Models and Simulations Supporting Airworthiness-Related Decision-Making.

[RA 5815](#) Instructions for Sustaining Type Airworthiness. ◀

[RA 5820](#) Changes in Type Design (MRP Part 21 Subpart D).

c. ▶ **MAA Manuals**

[MMAR](#) Manual of Military Airworthiness Recognition. ◀

d. **Other References**

[European Union Aviation Safety Agency \(EASA\) Part 21](#) – Airworthiness and Environmental Certification.

Context

2. The MAA is empowered through the Defence Safety Authority (DSA) Charter from the Secretary of State for Defence (SoS) to regulate all Air Systems on the UK Military Aircraft Register (MAR). Its vision is ▶ 'To be a world leading Air Safety Regulator'. ◀ It sets out its requirements in the MAA Regulatory Publications (MRP) which apply to all within the Defence Air Environment (DAE), whether military or civilian.

3. **Background.** In the Nimrod Review, the Rt Hon Mr Justice Charles Haddon-Cave QC criticized the lack of clarity of the Military Certification process, stating that '*whilst the Certification process used in the civil sector to approve Type Designs and the Airworthiness of individual platforms clearly defines designer / manufacturer / operator responsibilities for Airworthiness, there is not the same clarity with respect to military aircraft, where responsibility for design / manufacture / maintenance is often shared between Industry and the IPTs and is confused*'. As a result, ▶ **the Review** ◀ recommended that the Regulator undertook a review of the Certification process for military ▶ **Air Systems** ◀ in order to align the Airworthiness Assurance processes used by the 3 Services and to establish clear lines of accountability for the design and manufacture of ▶ **Air System** ◀ types; in particular, the benefits of the civil Certification system were to be considered. In the SoS' response, the recommendation was agreed. and the MAA would establish Regulation for initial Certification.

4. **Regulation.** Against this context, [RA 1015](#)⁵ details the roles and responsibilities of the

⁵ Refer to [RA 1015](#) – Type Airworthiness Management – Roles and Responsibilities.

TAA⁶, [RA 5810](#)⁷ provides the regulatory requirements for achieving an MTC and [RA 5820](#)⁸ covers changes in Type Design.

5. **Changes to the MRP.** As Guidance Material for the management of Air System Type Design, the MMAC supports [RA 5810](#) and [RA 5820](#). Commensurate with revisions to these RAs, terminology coherency throughout the MRP is captured as business as usual Regulatory amendments. The authority for MACP terminology is founded within [RA 5810](#) and [RA 5820](#).

Scope

6. This Manual is applicable to crewed Air Systems, and Remotely Piloted Air System (RPAS) within the Certified Category⁹ (previously Class II / III).

Definitions

7. In addition to the MAA's Master Glossary ([MAA02](#)), the Defence Equipment & Support (DE&S) Airworthiness Team's ASPIRE Tools for Certification 'Terms and Taxonomy' and [EASA's Definitions and Abbreviations document](#), the following Table contains terms, abbreviations and definitions used within this Manual.

Table 1 – Glossary of Certification-Specific terms

Term	Abbreviation	Definition
Acceptable Means of Compliance	AMC	Acceptable Means of Compliance is primarily used to qualify technical interpretative material to be used in the Certification process and serves as means by which the Certification Requirements can be met. However, TAAs are not obliged to follow the stated AMC and may propose, for agreement, other means to demonstrate compliance (see Alternative Means of Compliance).
Accepted Certification Authority	ACA	Several Certification authorities have been accepted ► as ◀ having a Certification system comparable to that of the MAA. The civil regulators of Federal Aviation Administration (FAA) / EASA / UK Civil Aviation Authority (CAA) are automatically accepted; other national Military Airworthiness Regulators ► may be ◀ accepted following successful Recognition by the MAA. ► In the case of Military Accepted Certification Authorities (ACAs), these may be part of the National Military Airworthiness Authorities (NMAA) (as in the UK) or separate (as in Italy). See the MMAR ⁴ for further information. ◀
► Additional Certification Specification	-	Any element of a Certification Specification which forms part, but not the majority, of the Type Certification Basis (TCB). This may include different amendments of the Primary Certification Specification, or relevant sections from other Certification Specifications, eg Civil as the Primary Certification Specifications and Def Stan 00-970 as an Additional Certification Specification. ◀

⁶ ► Where the Air System is not UK MOD-owned, Type Airworthiness (TAW) management regulatory responsibility by either the TAA or Type Airworthiness Manager (TAM) needs to be agreed within the Sponsor's approved model; refer to RA 1162 – Air Safety Governance Arrangements for Civilian Operated (Development) and (In-Service) Air Systems or refer to RA 1163 – Air Safety Governance Arrangements for Special Case Flying Air Systems. Dependent on the agreed delegation of TAW responsibilities TAM may be read in place of TAA as appropriate throughout this Manual. ◀

⁷ Refer to [RA 5810](#) – Military Type Certificate (MRP Part 21 Subpart B).

⁸ Refer to [RA 5820](#) – Changes in Type Design (MRP Part 21 Subpart D).

⁹ Refer to [RA 1600](#) – Remotely Piloted Air Systems.

Term	Abbreviation	Definition
Affected	-	When considering a TCB for a change to Type Design, an Airworthiness Requirement is Affected if the potential exists for the Design change to impact that Requirement. Thus, examples of a Not-Affected Airworthiness Requirement are those associated with Landing Gear design when the Type Design change is purely associated with modified cockpit displays.
Airworthiness Limitation	-	Airworthiness Limitation are established within the Instructions for Sustaining Type Airworthiness (ISTA - MAA) or Instructions for Continuing Airworthiness (ICA - Civil) and form part of the Type Design for the Air System. These Limitations define mandatory replacement times, structural inspection intervals and related structural inspection procedures required for Type Certification.
► Alternative Acceptable Means of Compliance	AAMC	Acceptable Means of Compliance (AMC) represents the preferred means by which the MAA expects the intent of the Regulation to be met. Therefore, if the Regulated Entity believes it can better achieve the intent of the Regulation by using an Alternative AMC (AAMC), it may formally apply to the MAA to have this alternative means approved. ◀
Alternative Certification Specification	-	Several nations have their own Certification Specifications that can be used as an alternative to the UK benchmark Def Stan 00-970, provided that the requirements are comparable, in terms of Airworthiness outcomes, and they provide a level of Safety that is acceptable to the MAA.
Alternative Means of Compliance	AltMoC	► If literal compliance with the Certification Specifications defined in the agreed Type Certification Basis cannot be demonstrated, the Regulator may accept mitigating procedures or factors which demonstrate that the Essential Requirements for Airworthiness are satisfied. ◀
Applicable	-	When considering a TCB for ► an Air System, an Airworthiness Requirement is Applicable if the potential exists for that Requirement to be relevant to the Type Design. ◀ Thus, an example of Non-Applicable (N/A) Airworthiness Requirements are those associated with Brake Parachutes (Def Stan 00-970 Part 1) where the Air System Type Design has no Brake Parachute installation.
Approved Design Changes Certificate	ADCC	An ADCC is the MAA-issued Certificate which signifies that a change ►, or changes ◀ to Type Design for a Legacy Air System, ► have been satisfactorily processed through the MACP. ◀
Certification Airworthiness Requirement	-	Certification Airworthiness Requirements (hereafter referred to as 'Certification Requirements') are the individual design requirements, from the chosen Certification Specification for Airworthiness, against which compliance will be shown in order to establish a minimum level of Airworthiness.
Certification Specification for Airworthiness	-	A Certification Specification for Airworthiness (hereafter referred to as 'Certification Specification') is a document, often referencing a number of associated design Standards, that comprises hundreds of Certification Requirements against which a designer must ► ◀ comply in order to establish a minimum level of Airworthiness for their Air System and thereby assure an Airworthiness Regulator to issue a Type Certificate.

Term	Abbreviation	Definition
Certification Log	-	The Certification Log is a key document and evolves from simply containing the TCB (at MACP Phase 2) to also contain details such as; applicable Military Certification Review Items (MCRIs), Means of Compliance Codes (MC) and associated Levels of Involvement (LOI), Compliance Demonstration Items (CDI) and independent Assurance.
Certification Programme	CP	Established during MACP Phase 3, the CP is a document that allows the TAA and the MAA to manage and control the evolving Type Design, as well as the process of compliance demonstration against each requirement of the agreed TCB by the TAA and its verification by the MAA when required. The CP will define the Means of Compliance Codes and associated Levels of Involvement for the TAA and MAA.
Certification Strategy	-	The Certification Strategy is the TAA's document that defines their approach to the MACP; this strategy will be shared with, and agreed by, the MAA. Whilst this Strategy could be defined within the wider Airworthiness Strategy, a separate MACP-focused document is preferred.
Changed Product Rule	CPR	A change to Type Design will normally comply with Certification Specifications applicable on the date of application, the TAA can propose, for MAA agreement, to comply with requirements from an earlier amendment of the Certification Specifications when: the change is either Minor or Not Significant; an area, system, part or appliance is not affected by the change; compliance with the latest amendment for a Significant change does not contribute materially to the level of Safety; or compliance with the latest amendment would be impractical.
Classification (of Design Change)	-	Classification of changes in Type Design as Minor or Major is required to determine the Approval and Assurance route to be followed and is related to the Airworthiness implications of that change. Major changes are subsequently classified as Substantial, Significant and Not Significant. Note that Change Classification is not the same as Modification classifications iaw Def Stan 05-057.
► Code of Federal Regulations	CFR	Regulations and Certification Specifications published by the FAA as part of Title 14 of the Code of Federal Regulations. Eg 14 CFR Part XX. ◀
Comparable Requirement	-	When opting to use a Certification Specification other than the UK benchmark Def Stan 00-970, a comparable requirement is one from the alternative Certification Specification that achieves a level of Safety that is both; (1) as good as that achieved through compliance with Def Stan 00-970 and (2) is acceptable to the MAA.
Compliant	-	A Compliant Certification Requirement is one where evidence successfully supports the technical interpretative material provided within; the established AMC, agreed Special Conditions, Equivalent Safety Finding ► or Deviation. ◀ Thus, a Non-Compliant Certification requirement is one where the evidence falls short of showing full compliance. Note, that the use of the term 'Partially Compliant' is to be avoided; requirements are either wholly compliant or otherwise are non-compliant.

Term	Abbreviation	Definition
Compliance Demonstration Item	CDI	A CDI is a meaningful group of compliance demonstration activities and data which can be considered in isolation for the purpose of the MAA assessing the proposed Level of Involvement using a Risk-based approach.
► Compliance Verification Engineer	CVE	An engineer employed within Design Organization to carry out an independent verification function. See MAA/RN/2020/17 Function of the Compliance Verification Engineer Explained for further details. Note that other nation's Regulators may have similar arrangements but use different terminology.
Credit	-	Written Approval from the MAA that Type Certification activities previously carried out by an ACA can be used by the TAA where applicable to UK MOD configuration and intended usage. ◀
Defence Standard 00-970	Def Stan 00-970	Def Stan 00-970 is the UK ► Military ◀ default Certification Specification for Airworthiness and, as such, is used as the comparator when Alternative Certification Specifications are proposed for use within a Certification ► project . ◀
Def Stan 00-970 Transformation	-	Def Stan 00-970 Transformation was a programme of activity during 2016-2021 to update Def Stan 00-970 such that it deferred, as far as possible, to civil Certification Specifications, whilst retaining military-specific Certification Specifications (termed 'Military Deltas') where necessary.
Deviation	DEV	► ◀ A Deviation records that the level of Safety targeted by the Essential Requirements ► for Airworthiness ◀ is achieved through mitigating factors, although the ► ◀ design does not comply with the Certification specifications or Special Conditions, neither literally nor with its intent. Mitigating factors might be: operational and / or Airworthiness limitations, inspections, limitations to the number of flight hours or flight cycles and / or Aircraft serial numbers. Limitations might be combined with alternative requirements to the CS, or dedicated characteristics of the design and / or procedures that ensure compliance to the essential requirements. ► The MAA application of the Deviation process is broadly similar to that employed by Civil Regulators but with some differences. For example, MAA Deviations are not subject to Public Consultation. ◀
Elect to Comply	EtC	It is possible for a TAA to EtC with a Certification Specification that entered into force after the date of the application. The MAA will assess whether the proposed Certification basis is appropriate to ensure that the 'EtC proposal' includes any other Certification Specifications that are 'directly related'; ie those that are deemed to contribute to the same Safety objective by building on each other's requirements, addressing complementary aspects of the same Safety concern.

Term	Abbreviation	Definition
Equivalent Level of Safety	ELoS	<p>► Where compliance with a TCB requirement cannot be demonstrated, but the TAA believes that this can be mitigated by additional controls and / or compensating factors, the TAA can propose an ELoS argument, via an MCRI, in order for the MAA to make an Equivalent Safety Finding (ESF), if appropriate.</p> <p>To achieve an ELoS, the TAA must demonstrate that the applicable non-Compliance with TCB requirements can be mitigated by additional controls and / or compensating factors, such that the Air System can be expected to achieve equivalent Safety outcomes to a fully compliant Air System with regards to the applicable Airworthiness Requirement. For any ELoS argument that requires controls, factors, or mitigations that are outside of the TAA's Area of Responsibility (AoR), the MAA will expect to see evidence of acceptance by an appropriate owner.</p> <p>For Minor changes, the responsibility for the Approval of ESFs is delegated to the TAA. ◀</p>
Equivalent Safety Finding	ESF	<p>An ESF is the outcome of the MAA's assessment of the TAA's ELoS proposal, if successful. The ESF will be included in the Type Certification Basis for the Air System, or Major Change.</p> <p>► For Minor changes, TAAs can approve an ESF and the MAA only needs to be informed of this outcome. ◀</p>
► Essential Requirements for Airworthiness	-	<p>The MAA's Essential Requirements for Airworthiness are based on CAA requirements defined in Annex II to UK Regulation (EU) 2018/1139. These requirements form the minimum requirements for Type Certification and are the basis for the detailed Certification Specifications. These Essential Requirements will be used by the MAA when considering a request for a Deviation from the applicable Certification Specifications.</p>
Exemption	-	<p>FAA term equivalent to a Deviation ◀</p>
Form 30	-	<p>The MAA Form 30 is the method by which TAAs apply to the MAA for Certification Assurance of new Type Designs or Major Changes to existing Type Designs. For Minor Change to Type Design, TAAs can elect to use the DE&S ASPIRE-based DE&S Airworthiness Team (DAT) Form 30 / Major-Minor Change Record.</p>
► Interpretative Material	IM	<p>IM is recorded in an MCRI to provide additional guidance on understanding a Certification Specification Requirement. IM may have a significant impact on the design and on the compliance demonstration and will be identified as early as possible in an MCRI for the MAA and the TAA to reach agreement of how a generic Certification requirement may be interpreted and / or compliance demonstrated for a particular application. ◀</p>
Legacy Air System	-	<p>In general, a Legacy Air System is one that was already in Service prior to the introduction of the MACP in 2011. Therefore, noting that the MACP was not retrospective, these Legacy Air Systems have not undergone MACP Type Design Assurance by the MAA.</p>
► Level of Assurance		<p>TAA recommendation made on the MAA Form 30 for design change level of Assurance – DO Assurance under privilege with TAA Oversight; TAA Assurance with MAA Oversight; or MAA Assurance. ◀</p>

Term	Abbreviation	Definition
Level of Involvement	LOI	When agreeing the Certification Programme (MACP Phase 3), the TAA needs to determine their LOI, and propose the MAA's LOI, with the Design Organization (DO); this LOI defines the compliance demonstration activities that the TAA / MAA requires for verification and is based on the risk associated with the likelihood of an unidentified non-compliance.
Major Change	-	A Major change to Type Design, or a Major Repair, is one that has an appreciable effect on ► the mass, balance, structural strength, operational characteristics, armament system, or other characteristics affecting the Airworthiness of the Air System. ◀
Means of Compliance Code	MC	When agreeing the Certification Programme (MACP Phase 3), the TAA will define an MC, for each Certification Requirement or CDI, which determines what the compliance evidence will be. The 4 broad compliance evidence types (Engineering Evaluation, Tests, Inspection and Equipment Qualification) are sub-divided into 10 MC.
MOD's Approach to Investment Decisions	MAID	The MOD Acquisition system utilizes the Concept, Assessment, Demonstration, Manufacture, In-service and Disposal (CADMID) cycle for through-life project management. Under the MAID the CADMID cycle for project Acquisition management comprises of a 3-stage Approval process consisting of the Strategic Outline Case (SOC), the Outline Business Case (OBC) and the Full Business Case (FBC). With respect to the application of this Manual to capability programmes established prior to MAID, all references to OBC are to be read as Initial Gate (IG) and all references to FBC are to be read as Main Gate (MG).
Military Air System Certification Process	MACP	The six-phase MACP consists of a demonstration that the Type Design meets appropriate Airworthiness requirements together with the generation of Release To Service Recommendations ► ◀ (RTSR), supported by evidence, that the Air System is safe to operate in the Service Environment.
MACP Action	MACP Action	Previously termed 'Post-Certification Action (PCA)', a MACP Action is any Action raised by the MAA during the MACP.
Military Certification Review Item	MCRI	The MCRI is a tool for any occasion where Certification issues require clarification and / or interpretation. A MCRI records the reason why a Certification requirement is under review, how it will be addressed and the final outcome of agreement between the MAA and TAA.
Military Type Certificate	MTC	An MTC is the MAA-issued Certificate which signifies that a new Air System has completed the MACP satisfactorily.
Minor Change	-	A Minor change to Type Design, or a Minor Repair, is one that has no appreciable effect on ► the mass, balance, structural strength, operational characteristics, armament system, or other characteristics affecting the Airworthiness of the Air System. ◀
'Minor-Minor' Change	-	► More properly defined as "Minor Changes requiring no further demonstration of compliance". Although the term is not used within the MRP, very simple changes to Type Design, or Repairs, that require no further demonstration showing of compliance, because the evidence supporting compliance with the TCB is not affected, ◀ are colloquially know as 'Minor-Minor' changes. The tailorable MACP ensures that TAAs can appropriately reduce the ► level ◀ of Assurance for these changes that require no further showing of compliance.

Term	Abbreviation	Definition
Operating Limitation	-	Operating Limitations are established within the Aircraft Flight Manual (AFM - Civil) or Air System Release To Service (RTS - MAA) and form part of the Type Design for the Air System. Amongst other factors, these Limitations define airspeed and rotor limitations, powerplant limitations, weight and loading distribution, flight crew, kinds of operation, limiting heights, max allowable wind, altitude, ambient temperature.
► Operational Suitability Data	OSD	Data that DOs are mandated to establish by civil Regulators (and gain certifying authority Approval) for safe operation of the Air System consisting of: The Master Minimum Equipment List; data for training of pilots; data for cabin crew; data for training of Maintenance crew; and data for qualification of simulators. ◀
Part A Review	-	The first stage in determining the amount of credit that can be claimed through Recognition, the Part A Review assesses the appropriateness of the ACA's TCB and that it delivers a level of Safety that is both comparable to the UK baseline Def Stan 00-970 and acceptable to the MAA. Thus, the Part A will identify what additional activity will need to be undertaken.
Part B Review	-	The Part B Review is the satisfactory resolution of Part A Review findings; validation of the original assessments made by the ACA; and, the determination of the amount of credit that could be claimed towards demonstrating compliance with the MACP.
► Programmable Elements	PE	Software or programmable hardware, which includes any device and data that can be customised. ◀
Platform Certification Lead	PCL	Within the MAA's Certification Division, the PCL is ► one of the Heads of Branch nominated as the lead for a particular Air System. In general, responsibility is DE&S Operating Centre-facing with Cert S&ADS is responsible for all Helicopter Rotary Wing Air Systems; Cert MPS is responsible for all large Director Air Support Air Systems and Cert ES responsible for all fast jet Combat Air Systems and RPAS. UK Military Flying Training System Air Systems are split by Rotary and Fixed Wing and there are invariably exceptions to the general rule. ◀
► Primary Certification Specification		The Certification Specification from which the majority of Type Certification Basis Requirements are drawn. ◀
Project Certification Manager	PCM	Within the MAA's Certification Division, the PCM is the Single Point of Contact (SPOC) for the TAA and their Air System Delivery Team (DT) Certification staff during the MACP. The PCM leads the team of Subject Matter Experts who will be responsible for assessing the various artefacts delivered for assessment by the DT. Thus, MAA PCMs are project specific.
Project & Task Co-ordination Cell	PTC	Within the MAA's Certification Division, PTC is the SPOC for all enquiries relating to Certification, including the recipients of all completed MAA Form 30 submissions.
Recognition	-	► The structured process used by the MAA to evaluate a foreign Military Airworthiness Authority and assess the potential to use their Airworthiness organizational Approvals or Certification Artefacts within the MAA Regulatory Publications. ◀
Release to Service Recommendations - Audit Report	RTSR-AR	The RTSR-AR is the outcome of the MAA's MACP Phase 5 Audit of the TAA's RTSR submission; this Audit will include the relevant Type Airworthiness Safety Assessment (TASA) and Air System Document Set.

Term	Abbreviation	Definition
Restricted Certificate	-	<p>Civil: A Restricted Type Certificate shows that the design provides a level of Safety that is adequate with regard to the intended use.</p> <p>MAA: A Restricted Certificate, either a Restricted MTC (RMTC) or Restricted ADCC (RADCC) will be issued where ▶ compliance with the TCB has not been fully demonstrated, but the MAA has assessed that the level of Safety which is demonstrated to be adequate with regard to the intended use. ◀</p>
Significant (Design Change)	-	Major Type Design change is considered 'Significant' if the change relates to one or more of the following: general configuration; principles of construction; or the assumptions used for Certification (including usage).
Special Condition	SC	If Certification Specifications do not provide adequate standards (ie for the Certification of novel technology), the MAA will define SC that the TAA will need to comply with.
▶ Statement of Type Design Assurance	STDA	<p>Obsolescent term for the outcome of a tailored application of the MACP, using the withdrawn obsolescent RA 1500, for Legacy Air Systems. STDAs are no longer issued by MAA.</p> <p>The STDA articulates the level of Assurance provided by the MAA that the requirements of the MACP had been satisfied (ie No Assurance, Limited Assurance, Substantial Assurance or Full Assurance). ◀</p>
Substantial (Design Change)	-	A Major Type Design change is considered 'Substantial' if it is so extensive that a substantially complete investigation of compliance with the applicable TCB is required and a new MTC is required.
▶ Technical Standard Order	TSO	A TSO is a detailed Airworthiness specification issued by an appropriate Authority to assure compliance with the essential Certification requirements for a specific article. TSOs issued by EASA are known as ETSOs whilst European Military Airworthiness Requirements (EMAR) 21 refers to Military TSOs (MTSOs), issued by National Military Authorities. ◀
Type Airworthiness responsibility	-	<p>▶ Where the Air System is not UK MOD-owned, TAW management regulatory responsibility by either the TAA or TAM needs to be agreed within the Sponsor's approved model. ◀ For Civilian-Owned and Civilian Operated Air Systems, the Air System Sponsor could split TAW responsibility⁶ between the TAA and a TAM. Specifically, regarding Certification activity, the TAA will provide advice to the Sponsor on the most appropriate split of TAW design change responsibilities, noting that a TAM will only be permitted to classify, not approve, Major Changes.</p> <p>▶ Specifically, for Non-UK-Owned and Civilian Operated Air Systems the TAM will only be permitted to classify, not approve, Major Changes. ◀</p>
Type Certificate	TC	<p>Civil: A Type Certificate signifies the Airworthiness of a particular category of Aircraft, according to its manufacturing design (Type Design). It confirms that the Aircraft of a new type intended for serial production, complies with the applicable Airworthiness requirements.</p> <p>MAA: See MTC.</p>

Term	Abbreviation	Definition
Type Certification Basis	TCB	► The TCB is the agreed set of Certification requirements, including Airworthiness codes and Special Conditions, that are applicable to the Air System Type Design and will be demonstrated in the compliance activity in order to obtain a Military Type Certificate.
Type Certification Boundary	-	The elements of the Air System that will be certified. ◀
Type Certification Exposition	TCE	The TCE will consist of a claim (or number of claims), a structured and explicit argument, and a supporting body of evidence (as detailed in the CP), that together provide a compelling, comprehensible and valid case that the Air System's Type Design is compliant with the agreed TCB.
Type Certification Report	TCR	The TCR is the outcome of the MAA's review of the TCE to provide independent Assurance that the Type Design has been shown to meet Airworthiness requirements through satisfactory completion of the MACP.
Type Design	-	Type Design is all the drawings and specifications that show compliance with the Certification basis of the original Air System and all the data necessary to show that subsequent Air Systems conform to the approved Type Design.
► Type Design Examination	TDE	A structured process carried out jointly between the MAA and TAA to review the Certification activities of another Airworthiness Authority for a particular Air System Type in order to determine the Certification credit towards completion of the MACP. ◀

Chapter 2: Certification of Air System Type Designs (MRP Part 21 Subpart B) and the Military Air System Certification Process (MACP)

Introduction

1. For new Air Systems operated on the UK MAR, within the Service Environment, it is necessary to demonstrate that its Type Design meets appropriate Airworthiness requirements. As a result, a systematic, independent Airworthiness Certification process is required for new types of UK military registered Air Systems. The award of an MTC demonstrates that the military Air System Type Design has been shown to meet appropriate Airworthiness requirements through satisfactory completion of the MACP. This Chapter supports [RA 5810](#) which is the core Regulation for Type Certification and the MACP.

Figure 1 – MACP 6-Phase Approach

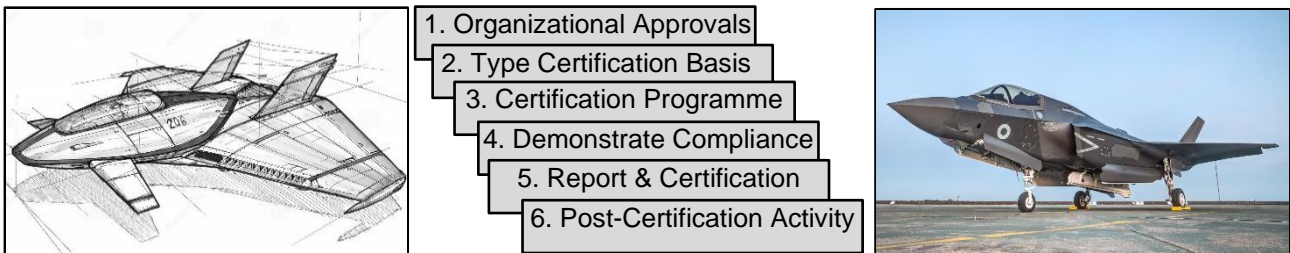

2. From conceptual design to an in-Service Air System can take many years; consequently, a robust, structured framework for Certification ensures that the necessary foundations are established before more-detailed activity is undertaken. This framework, the MACP, comprises 6 phases, some of which may run concurrently as shown at **Figure 2**. The first 2 phases commence before FBC and therefore the TAA needs to reach an agreement with the MAA on the approach to be taken for the key elements of Phases 1 and 2, before seeking the requisite FBC Approval; this is achieved through the MAA’s agreement of the TAA’s Certification Strategy, which can either be part of their Airworthiness Strategy or, ideally, a standalone document for this specific project.

Figure 2 – MACP Phase within the CADMID Cycle

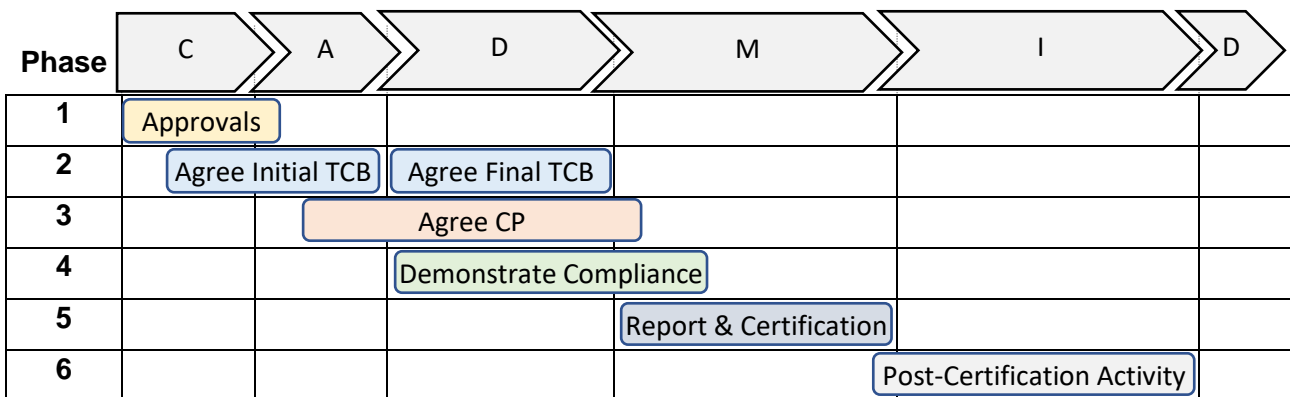

3. To support efficient progress through the MACP, the TAA will establish a Certification Strategy detailing the intended approach to type Certification, the intended management arrangements and scheduled key milestones with MAA agreement. These milestones enable the MAA Certification Division to plan the project’s Certification activity amongst the wider portfolio of concurrent Certification **▶ activity ◀**. As a result, failure to meet planned milestones, even by a small amount, can result in a disproportionate delay to the MAA’s ability to staff the activity due to conflicting activity. Consequently, it is strongly recommended that Certification schedules are robust and take account of likely rework activity resulting from MAA Assurance activity. **Table 2** below provides indicative MACP planning timescales; these are the minimum timescales achievable for the MAA Assurance of MACP. **Figure 3** shows how the MACP interfaces with the various transactional MACP activities of the TAA and MAA, including the artefacts produced.

Table 2 – Indicative (Minimum) MACP Planning Timescales

	TAA	Flow	MAA
D_{TCB}	Submit Initial TCB (iTCB) for MAA agreement	→	
D_{TCB} + 1 mth		←	Agree iTCB
D_{CP}	Submit CP for MAA agreement	→	
D_{CP} + 1 mth		←	Agree CP
D_{TCE}	Submit TCE for MAA Assurance review	→	
D_{TCE} + 1 mth		←	Review TCE and release TCR detailing outcome of TCE Assurance review
	Address , to the MAA's satisfaction, MACP Actions detailed in TCR	→	
D_{TCE} + 2 mths	Submit RTSR for MAA Audit	→	
D_{TCE} + 3 mths		←	Assure RTSR and issue Audit Report (AR) detailing outcome of RTSR Assurance activity
	Address , to the MAA's satisfaction, MACP Actions detail in RTSR-AR	→	
D_{TCE} + 4 mths		←	Issue Certificate [either an MTC or ADCC]
D_{TCE} + 4½ mths	Achieve RTS from RTS Authority (RTSA)		

Figure 3 – MACP Flow Diagram

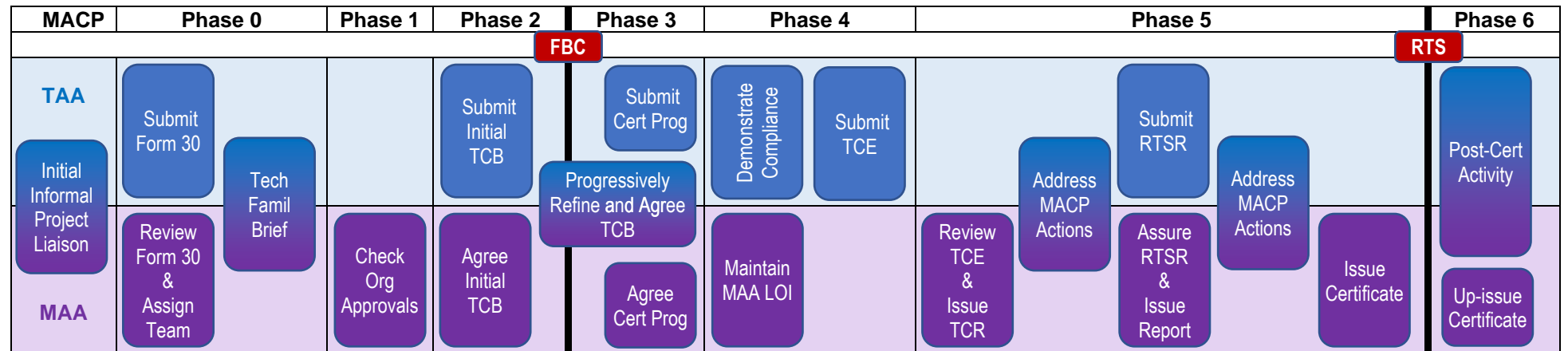

MACP

4. **Introduction.** The aim of Military Type Certification is to demonstrate the TAw of an Air System. Initial Type Certification is carried out prior to the introduction to service of a new Air System Type leading to the issuance of an MTC by the MAA. Subsequent changes to the Type Design (see [Chapter 3](#)), including changes in usage, Air System Document Set (ADS), or Maintenance philosophy, will require re-certification to be carried out. The six-phase MACP consists of a demonstration that the Type Design meets appropriate Airworthiness requirements together with the generation of RTSR, supported by evidence, that the Air System is safe to operate in the Service Environment. Thus, a large part of the MACP is assessing compliance with the wider MAA Regulatory Publication as it relates to the Type Design of the Air System.

5. **► Definition of the Type Certification Boundary.** Essential for a successful Certification project is the exact definition of the Air System at an early phase of the project. This is because the scope of Type Certification extends beyond the physical attributes of the 'core' Aircraft and may include elements such as technical and operating manuals, engineering data, ground support equipment and RPAS Ground Stations. Similarly, the Air System may be destined to be operated with role equipment and / or weapons that would not be included in the scope of Type Certification. Therefore, the Certification Strategy for a new Air System will include a description of those aspects of the Air System are included in, and excluded from, the Type Certification Boundary.

6. **Type Design¹⁰.** It is equally important to define what is meant by the 'Type Design'. For the purpose of the MACP, ◀ the Type Design will comprise of the following information:

- a. The drawings and specifications (or equivalent), and a listing of those drawings and specifications, necessary to define the configuration and the design features of the Air System shown to comply with the applicable TCB.
- b. Information on materials and processes, and on methods of manufacture and assembly necessary to ensure the conformity of the Air System.
- c. An approved Airworthiness limitations section of the Instructions for Sustaining TAw¹¹ as defined by the applicable Certification Specifications.
- d. Any other data necessary to allow, by comparison, the determination of the Airworthiness of later configurations of Air Systems of the same type.

Application

7. **Application¹².** The staffing process for the commencement of the MACP is determined by the nature of the Certification project, as follows:

- a. **New Air Systems.** All applications for a new Air System Type Design will be made to the MAA by the TAA using a MAA Form 30.
- b. **Type Design changes.** The staffing of applications for changes to an existing Type Design is dependent upon the [Classification](#) of that change.
 - (1) **Minor.** For Minor Type Design changes, TAAs can elect to use the DE&S ASPIRE ►◀ DAT Form 30 / Major-Minor Change Record in lieu of a MAA Form 30. Similarly, when a Minor Change is classified or approved by an approved DO under the privilege procedure, the DO must inform the TAA to ensure that configuration control is maintained.
 - (2) **Major.** ► Applications for ◀ Major changes to an existing Type Design will be made to the MAA by the TAA using a MAA Form 30. ► The DE&S ASPIRE-based DAT Form 30 / Major-Minor Change Record provides the Audit trail for the classification rationale to be submitted alongside the MAA Form 30. ◀

¹⁰ Refer to [RA 5810\(10\)](#): Type Design (MRP Part 21.A.31).

¹¹ Refer to [RA 5815](#) – Instructions for Sustaining Type Airworthiness.

¹² Refer to [RA 5810\(3\)](#): Application (MRP Part 21.A.15).

- c. **MAA Form 30.** The MAA Form 30 will include preliminary descriptive data of the Air System, its intended use, and the kind of operations for which Certification is requested. Additionally, the application will detail the DO involved and any extant civil Type Certification.
- d. **Tech Famil Brief.** Alongside the Form 30 submission to the MAA for a new Air System or Major Type Design change, the DT will be expected to deliver a technical familiarization brief to the MAA Certification Team.

Phase 1 - Identify the requirement for, and obtain, organizational Approvals.

8. **Approved Organization Schemes.** Organizations within the DAE may be [contracted](#)¹³ to carry out specified Design, Maintenance, and Contractor Flying activities. Not having competent organizations contracted to carry out these activities may result in a compromised level of Air Safety. To assure the SoS for Defence that organizations contracted to provide Air Safety related products and services to the UK MOD are competent to do so, the MAA provides a number of Approval schemes.
- a. [Design Approved Organization Scheme \(DAOS\)](#)¹⁴. Organizations with Airworthiness responsibilities for the design of new Air Systems or **► Type Design Changes ◀** must hold an appropriate design Approval¹⁵. Normally these will be through DAOS, but alternative Approvals may be acceptable where the TAA can demonstrate to the MAA that they are comparable and appropriate to the prevailing circumstances.
 - b. [Contractor Flying Approved Organization Scheme \(CFAOS\)](#)¹⁶. Defence Contractor Flying Organizations that operate UK military registered Air Systems not in the UK MOD Service Environment are required to operate under an appropriate approval scheme, CFAOS, which ensures organizations comply with the MRP.
 - c. [Maintenance Approved Organization Scheme \(MAOS\)](#)¹⁷. On-Aircraft Maintenance, and off-Aircraft Maintenance that is carried out on UK Government property, can only be carried out by organizations that are required to operate under an appropriate Approval scheme, MAOS, which ensures their management, technical resources and Quality Assurance arrangements are demonstrably adequate to provide products and services of the required Quality, economically and on time.
9. **Independent Evaluation and Audit.** The arrangements for ensuring Independent evaluation and Audit¹⁸ by the Independent Technical Evaluator (ITE) and Independent Safety Auditor (ISA) will need to be detailed. The ITE and ISA will be competent and suitably qualified individuals or teams, as determined by the TAA, and they will be independent of the outcome or processes they are reviewing.
10. **Regulators.** The MAA can provide guidance on projects intending to use organizational Approvals from foreign Military Airworthiness Regulators or Civil Airworthiness Regulators (eg EASA, FAA or CAA) as credit for Phase 1 (see **► the [MMAR](#) and ◀ also [Chapter 5](#)**).
11. **TAA's.** TAAs involved in the introduction of new Air Systems or Major changes to existing Air Systems must hold appropriate [Letters of Airworthiness Authority \(LoAAs\)](#)¹⁹, and ensure that the requirements for an [Independent Evaluation and Audit](#) are considered²⁰.
12. **► Aviation Duty Holders (ADH) and Accountable Managers (Military Flying) (AM(MF)).** During the Certification process, TAAs may need to obtain acceptance of elevated Risk to Life (RtL) or operating mitigations. This acceptance will usually be provided by an ADH. However, references to the ADH in this Manual can be assumed to include the AM(MF) for Civil Owned and / or Operated Military Air Systems.²¹ ◀

¹³ Refer to [RA 1005](#) – Contracting with Competent Organizations.

¹⁴ Refer to [RA 5850](#) – Military Design Approved Organization (MRP Part 21 Subpart J).

¹⁵ Refer to [RA 5810\(2\)](#): Demonstration of Capability (MRP Part 21.A.14).

¹⁶ Refer to [RA 1028](#) – Contractor Flying Approved Organization Scheme **► ◀**.

¹⁷ Refer to [RA 4800 Series](#) – Continuing Airworthiness Engineering (CAE) Regulations.

¹⁸ **► Refer to [RA 5012\(1\): Guidance Material - Independent Evaluation and Audit.](#) ◀**

¹⁹ Refer to [RA 1003](#) – Delegation of Airworthiness Authority and Notification of Air Safety Responsibility.

²⁰ **► Refer to [RA 5011](#) – Type Airworthiness Safety Management System.** ◀

²¹ **► Refer to [RA 1160](#) – The Defence Air Environment Operating Framework.** ◀

Phase 2 - Establish and Agree the TCB²²

13. **TCB.** It is necessary to establish the TCB for the Type Design of the Air System or a proposed Major change to the Type Design, as follows and shown at **Figure 4**:

a. **New Type Design.** Establishing an Air System TCB for a new Type Design involves: selection of an applicable [Certification Specification for Airworthiness](#) (hereafter simply referred to as 'Certification Specification'); selection of alternative Certification Specifications where required; a clear statement as to which versions of the selected specifications will be applied; and the identification of any areas that may fall under the consideration of a [MCRI](#).

(1) **iTCB.** The iTCB is the first TCB that the TAA, as the Applicant for an MTC, agrees with the MAA – this agreement needs to occur prior to Acquisition project FBC. As a result, with the Type Design potentially not fully developed at that stage, the iTCB is likely to be pessimistic and include all Certification Airworthiness Requirements, from the chosen Certification Specification(s), that may be applicable to the Type Design.

► **The iTCB will need to be informed by an appropriately endorsed Statement of Operating Intent which will need to be produced during this Phase.** ◀ As the Type Design evolves as the MACP progresses, it will become clearer to the TAA which of these iTCB Requirements are Applicable and which are Not Applicable. Thus, the TCB matures from iTCB to the Final TCB, which is often not confirmed until the completion of [MACP Phase 4](#) once all of the compliance evidence is known. ►◀

(2) ► **Final TCB.** The Final TCB will contain all of the applicable Requirements, along with any applicable [SC](#) and [ELOS / ESF](#) arguments derived through the [MCRI process](#). Note that every iteration of the TCB needs to be agreed by the MAA and it is important to finalize the TCB prior to the MAA's TCE review ([MACP Phase 5](#)). ◀

b. **Change to Type Design.** Establishing a TCB for a change to an existing Type Design involves the identification of affected Certification Requirements from the Air System TCB in order to develop a TCB for the design change (Major and Minor). ► **Many Legacy Air Systems have not undergone the full MACP prior to entry to Service; as a result, these Legacy Air Systems will not have an agreed Air System TCB. Consequently, the TAA needs to establish a bespoke TCB for each Type Design Change directly from the applicable Certification Specifications.** ◀

(1) ►◀

²² Refer to [RA 5810\(4\)](#): Type Certification Basis (MRP Part 21.A.15).

Figure 4 – Establishing a TCB for a new and changed Type Design

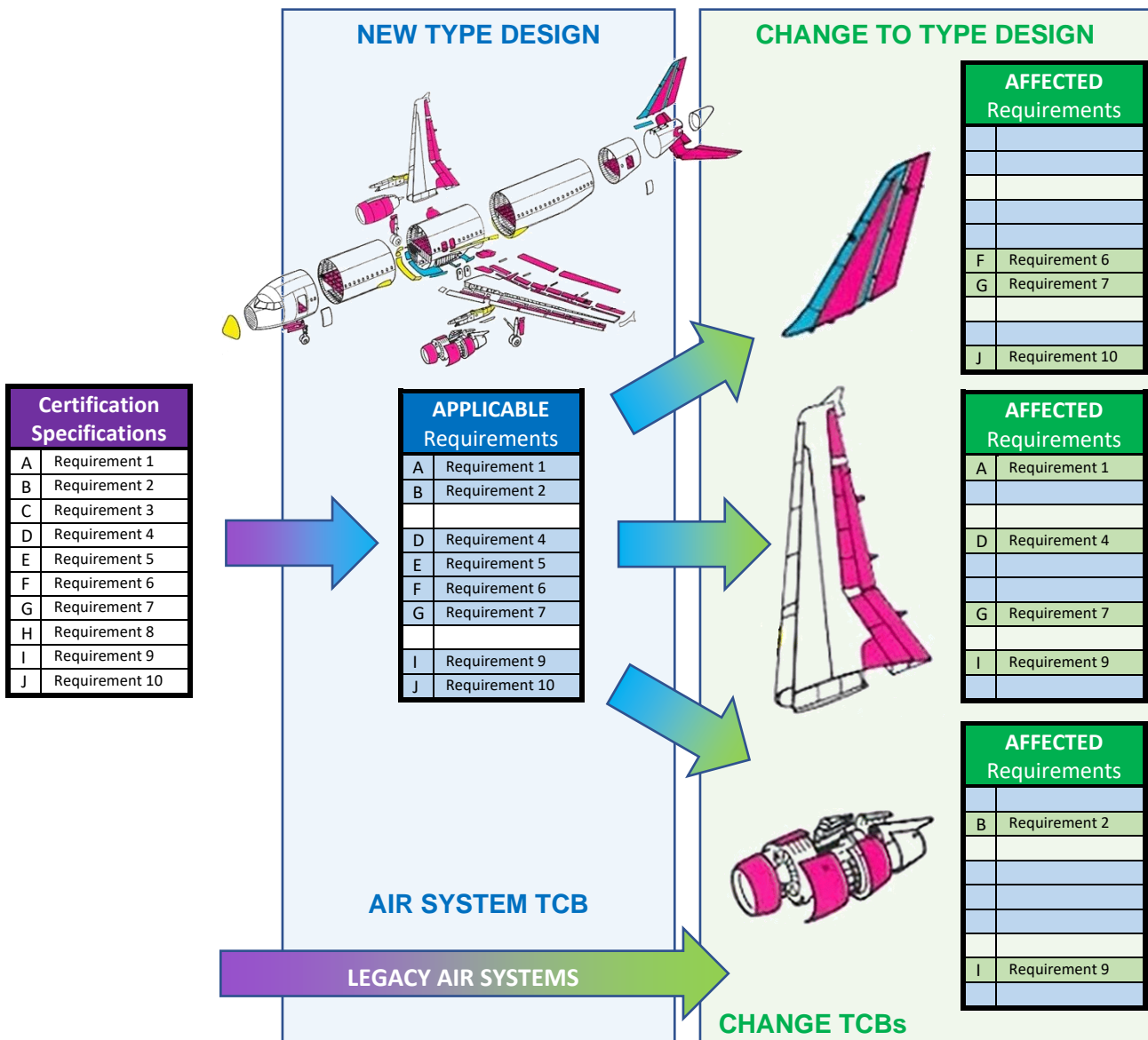

14. **Certification Specifications.** A Certification Specification is a document, often referencing a number of associated design Standards, that comprises of hundreds of Airworthiness requirements against which a designer must satisfactorily comply in order to establish a minimum level of Airworthiness for their Air System and thereby assure an Airworthiness Regulator to issue a Type Certificate. Certification Specification Airworthiness requirements represent the best contemporary design methods, often having incorporated lessons learned since the dawn of aviation. The TAA is responsible for intelligently selecting applicable Airworthiness requirements from the Certification Specification (termed ‘Tailoring’) in order to build a proposed TCB for Approval by the MAA. For the purposes of this Manual, the term Certification Specification is used in its generic sense, meaning that it is equally applicable to; primarily ‘standalone’ standards (such as [Def Stan 00-970](#) and EASA Certification Specifications), those standards that solely reference subordinate standards (such as Mil Hdbk 516C), or a tailored collection of bespoke standards and performance specifications etc.

15. **Applicable Certification Specification.** [Def Stan 00-970](#) is the default Certification Specification, but [other specifications or standards](#) may be proposed provided that they can be shown to deliver a level of Safety that is both consistent with the intent of [Def Stan 00-970](#) and is acceptable to the MAA. If the proposed primary Certification Specification is not [Def Stan 00-970](#), [MCRI A-03](#) references MCRI A-09 which proposes, for MAA agreement, the rationale for what [Def](#)

[Stan 00-970](#) requirements are applicable to Air Systems with a Primary Certification Specification other than [Def Stan 00-970](#). The TAA must ensure that the version of a Certification Specification in effect at the date of application will be applied unless compliance with Certification Specifications of an earlier effective amendment is chosen (ie for compatibility with the baseline design of the Air System), in which case the TAA will be required to demonstrate that this is the most appropriate approach and that any associated Risks are managed appropriately. For changes to Type Design²³ (see [Chapter 3](#)), the [CPR](#) can subsequently be applied. In all cases, the TAA is responsible for ensuring MAA access to any alternative Certification Specification used.

16. **MCRI**s. The MCRI is a tool for occasions where Certification issues require clarification and / or interpretation. A MCRI records the reason why a Certification requirement is under review, how it will be addressed and the final outcome of agreement between the MAA and TAA. As a result, a MCRI represents a recorded, chronological and auditable discussion between the TAA and the MAA; accordingly, to preserve a robust Audit trail, new narrative sections ► **may** ◀ be added by the TAA as required to present further evidence rather than simply amending the previously submitted narrative sections. The MCRI needs to clearly state the detail of the Certification Specification being used, including:

- a. Where the TAA intends to use Certification Requirements other than those from the primary Certification Specification (including other standards or specifications referenced), the MCRI needs to articulate with justification why the alternative Certification Requirement is appropriate and that its use will deliver a level of Safety that is both consistent with the intent of [Def Stan 00-970](#) and is acceptable to the MAA.
- b. Where existing Certification Specifications are judged to be inadequate, or do not exist, [SC](#) will be introduced into the TCB. These [SC](#) will contain such Safety standards that the TAA finds necessary to establish a level of Safety acceptable to the MAA.
- c. Where extant Certification requirements cannot be met, the TAA may propose ► **an ESF, where an ELoS can be demonstrated, or a Deviation, where Alternative Means of Compliance (AltMoC) are used to demonstrate that the Essential Requirements for Airworthiness have been satisfied.** ◀
- d. When a TAA intends to propose new Interpretive Material (IM) and use of ► **AltMoC** ◀ to the TCB.
- e. ► **In extremis, where the Essential Requirements for Airworthiness cannot be demonstrated to have been satisfied, the TAA may, if the ADH is willing to accept the elevated Rtl, seek to demonstrate that the level of Safety achieved is adequate with regard to the intended use of the Air System in order to justify the issue of an Restricted Certificate by the MAA.** ◀

17. **MCRI A-03** . As part of the process to establish a TCB for a new Air System, the TAA will generate an Administrative MCRI A-03²⁴ in order to clearly articulate and chronologically record all relevant discussions and agreements regarding the Military TCB with the MAA. MCRI A-03 will be generated as early as possible in the MACP, but no later than Phase 2, to propose and agree the applicable Certification Specification and amendment with the MAA. Part of the MCRI A-03 is used to record pre-existing certificates and agreements (Restrictions, ► **SCs, ESFs, Deviations,** ◀ Reversions, Exemptions, etc.) and ► **agree** ◀ applicability. The MCRI A-03 will then be updated for Major Design Changes.

18. **Format**. The TCB details all the applicable Certification Requirements, along with a description and any applicable [SC](#) and [ELOS / ESF](#). The DE&S ASPIRE Certification Log²⁵ is the preferred format to be submitted to the MAA for Approval as this enables the TAA to evolve this same document through the MACP.

19. **Validity**. The TCB only remains effective for 5 years from Form 30 submission; if MTC / RMTC is not achieved within that timescale, a review of the Certification Specifications that

²³ Refer to [RA 5820\(5\)](#): Designation of Applicable Certification Specifications for Airworthiness (MRP Part 21.A.101).

²⁴ Refer to the Air Engineers Toolkit – Process 8 Military Type Certification.

²⁵ Refer to the Air Engineers Toolkit – Military Type Certification.

underpin the TCB needs to be undertaken by the TAA in order to assess any shortfall against contemporary requirements.

20. **Operating Centre Director.** The TCB for new Air Systems must be [proposed by the relevant DE&S Operating Centre Director](#)²⁶ and agreed with the MAA prior to FBC Approval for the project.

Phase 3 - Agree the CP²⁷

21. **CP.** The CP is a document that allows the TAA and the MAA to manage and control the evolving Type Design, as well as the process of compliance demonstration against each requirement of the agreed TCB by the TAA and its verification by the MAA when required. Accordingly, the CP will include a number of key components, including:

- a. A detailed description of the Type Design.
- b. A Project Schedule, detailing:
 - (1) Major milestones such as TCE submission(s), RTSR submission and RTS target dates.
 - (2) Proposed arrangements for the delivery of Certification evidence for TAA and MAA review, noting that a phased / incremental TCE approach allows the work to be scheduled over a longer period thereby ensuring that issues are identified / addressed as early as possible to de-Risk ► project ◀ schedule delays. ► For any Inspections and Tests designated for MAA witness²⁸, the TAA must notify the MAA of dates as soon as practicable, and at least 6 weeks in advance for overseas travel. ◀
- c. Identification of key Airworthiness personnel.
- d. The Certification Log, containing the TCB agreed in Phase 2, is further developed to include the following detail:
 - (1) Any applicable MCRIs.
 - (2) The proposed MC and related documents.
 - (3) The proposed TAA and MAA Level of Involvement (LOI) in the verification of compliance demonstration activities.
 - (4) The involvement of Independent Assurance (ie ITE, ISA etc).
 - (5) The proposed breakdown of compliance demonstration activities.

22. The CP will be owned and managed by the TAA and agreed with the MAA, and will usually form part of the Integrated Test, Evaluation and Acceptance Plan (ITEAP). The CP can be developed in stages as the required information becomes available but will be agreed with the MAA Certification Division before compliance demonstration commences.

23. **MC.** The CP aspects of the Certification Log will, for each applicable requirement of the TCB, identify the following:

- a. The proposed MC (see **Table 3** for the relevant codes).

²⁶ Refer to [RA 1013](#) – Air System Operating Centre Director - Provision of Airworthy and Safe Systems.

²⁷ Refer to [RA 5810\(5\)](#): Certification Programme (MRP Part 21.A.15).

²⁸ ► Refer to paragraph 26. ◀

Table 3 – Means of Compliance Codes

Type of compliance	MC	Associated compliance documents
Engineering evaluation	MC0: (a) Compliance statement (b) Reference to design data (c) Election of methods, factors, etc (d) Definitions	(a) Design data (b) Recorded statements
	MC1: Design review	(c) Descriptions (d) Drawings
	MC2: Calculations / analysis	(e) Substantiation reports
	MC3: Safety Assessments	(f) Safety analysis
Tests	MC4: Laboratory tests	(g) Test programmes (h) Test reports (i) Test interpretations
	MC5: Ground tests on related product(s)	
	MC6: Flight tests	
	MC8: Simulation	
Inspection	MC7: Design inspection / Audit	(j) Inspections or Audit reports
Equipment qualification	MC9: Equipment qualification	Note: Equipment qualification is a process that may include all previous means of compliance at equipment level.

b. The compliance document(s) or evidence, which may include:

(1) Identification of industry standards (Society of Automotive Engineers (SAE), American Society for Testing and Materials (ASTM), European Organisation for Civil Aviation Equipment (EUROCAE), AeroSpace and Defence Industries Association of Europe (ASD), etc), methodology documents, handbooks, technical procedures, technical documents and specifications in the TCB, Certification memoranda, policy statements, guidance material, etc to be followed in the demonstration of compliance.

(2) When the compliance demonstration involves testing, a description of the ground and flight test article(s), test method(s), test location(s), test schedule, test house(s), test conditions (eg limit load, ultimate load), as well as of the intent / objective(s) of the testing.

(3) When the compliance demonstration involves analyses / calculations, a description/identification of the tools (eg name and version / release of the software programs) and methods used, the associated assumptions, limitations and / or conditions, as well as of the intended use and purpose; furthermore, the validation and verification of such tools and methods must be addressed.

For every aspect mentioned above, novel or unusual methods used to demonstrate compliance must be detailed in compliance documents, including any ►departures◄ from the published AMC to the relevant Certification specification.

c. Where appropriate, when the compliance documents or evidence will be available and include periodic progress reviews between the MAA, TAA and other relevant organizations.

24. **CDI.** The CP will include a proposal for a breakdown of the CP into meaningful groups of compliance demonstration activities and data; these groups are termed CDI. A CDI is a meaningful group of compliance demonstration activities and data which can be considered in isolation for the purpose of the MAA assessing the proposed LOI using a Risk-based approach. Each CDI must be sufficiently described in the CP to detail the scope of the CDI and information on its novelty, complexity, and criticality. The compliance demonstration activities and data grouped in a CDI may demonstrate compliance with a Certification requirement, a group of requirements, or even a part of a requirement, and will include the proposed MC (see [Table ►3◄](#)) and related compliance document(s) against each group. Accordingly, the CP may be sub-divided into CDI in several ways:

a. CDIs may be tailored to the scope and size of the project. On simple projects, a CDI may address all the compliance demonstration activities within a given 'module' or technical

area (eg avionics, flight, Structures, weapons systems integration, etc) or of the whole project. It is recommended that a CDI is neither too large, combining completely unrelated compliance demonstration activities or data, so that it becomes meaningless, nor so small that it might not be considered in isolation from some other related compliance demonstration activities or data.

b. A way of meaningfully grouping compliance demonstration activities and data, for example, is to select some activities and data and group them into a single CDI, as the CP must already contain the applicable requirements, the proposed means of compliance for each requirement, as well as the associated compliance documents for each means of compliance.

c. Another way to meaningfully group the data is to do it at the level of the technically related compliance demonstration activities and data. This may facilitate the assessment of those activities and data against their novelty, complexity, and criticality (measure of the potential impact of a non-compliance with part of the Certification basis on Air System Safety).

25. **LOI**²⁹. In defining the CP, the TAA need to determine their LOI, and propose the MAA's LOI, with the DO; this will need to be reviewed periodically with both the DO and MAA. The LOI will define the compliance demonstration activities and data (ie the CDI) that the TAA / MAA requires for verification during the Certification process, as well as the depth of the verification. The TAA / MAA will assess their required LOI based on the Risks associated with the likelihood of an unidentified non-compliance, and the design criticality, as follows:

a. The likelihood of an unidentified non-compliance and the associated Risk involved.

(1) The likelihood of an unidentified non-compliance is not to be confused with the likelihood of occurrence of an unsafe condition. The likelihood of an unidentified non-compliance will depend upon whether the CDI is novel or complex and the level of performance of the organizations involved.

(2) **Novel or unusual features of the Certification project, including operational, organizational and knowledge management aspects.** The determination that a CDI is novel may be driven by the use of new technology, new operations, new kind of installations, the use of new requirements or the use of new means of compliance.

(3) **The complexity of the design and / or compliance demonstration.** For each CDI, the determination of whether it is complex or not may vary based on factors such as the design, technology, associated manufacturing process, compliance demonstration (including test set-ups or analysis), interpretation of the results of the compliance demonstration, interfaces with other technical disciplines / CDIs, and the requirements.

(4) **The performance and experience of the TAA, the DT and the DO.** The MAA's assessment of the level of performance will consider the TAA's experience with the applicable Certification processes, including their performance on previous projects and their degree of familiarity with the applicable Certification requirements.

b. The criticality of the design or technology and the related Safety Risks, including those identified on similar designs. The potential impact of a non-compliance within a CDI will be classified as critical if, for example:

(1) A function, component or system is introduced or affected where the failure of that function, component or system may contribute to a failure condition that is classified as critical or catastrophic at the ► **Air System** ◀ level.

(2) A CDI has an appreciable effect on the human-machine interface (HMI) (displays, approved procedures, controls or alerts).

²⁹ Refer to [RA 5810\(11\)](#): Inspections and Test (MRP Part 21.A.33).

- (3) Airworthiness limitations or operating limitations are established or potentially affected.
- (4) A CDI is affected by, or potentially subject to, a known in-Service issue (ie Urgent Technical Inspection, Airworthiness Directive, Safety Information Bulletin, etc).
- (5) A CDI affects parts that are classified as critical or that have a critical or catastrophic failure consequence (eg Structural Significant Items, Critical Parts, Functional Significant Items etc).

26. The outcome of this Risk Assessment will enable the TAA to determine their LOI, and propose the MAA's LOI, with the DO. Additionally, the LOI will need to consider the compliance demonstration activities being undertaken, noting that some Certification activity will already be complete for Air Systems being procured as Commercial / Military 'Off The Shelf'. Thus, the LOI categories can be broadly considered to comprise of 5 levels (WAIRP), as follows:

- a. **W – Witness.** This will be used where the TAA / MAA wishes to **witness** testing that will subsequently deliver compliance evidence (ie flight test, fatigue test etc).
- b. **A – Approve.** This will be used where potential non-compliances are identified and the TAA / MAA expects to **approve** the resultant ELOS argument via a MCRI.
- c. **I – Information.** This will be used where the TAA / MAA only needs to be **informed** that the relevant TCB requirement has been included (ie such as marking of parts etc).
- d. **R – Report.** This will be used where the TAA / MAA wishes to review the compliance evidence **Test Report** (ie strength test reports, software design Assurance reports etc).
- e. **P – Plan.** This will be used where the TAA / MAA wishes to review and agree the **Test Plan** that will be used to produce the compliance evidence.

Phase 4 – Demonstrate Compliance³⁰

27. In order to demonstrate compliance, the TAA must provide the MAA with the evidence agreed with the MAA during Phase 3, as detailed in the CP and ensure that the MAA has been engaged according to the agreed LOI and all issues have been documented and addressed. The TCE will consist of a claim (or number of claims), a structured and explicit argument, and a supporting body of evidence, that together provide a compelling, comprehensible and valid case that the Air System's Type Design is compliant with the agreed TCB. For a new Air System Type Design, the TCE could be substantial; consequently, a phased compliance approach, involving incremental evidence submissions to the MAA, may provide valuable feedback to the TAA to inform their later submissions.

28. **Non-Compliances.** ► Where literal compliance cannot be demonstrated, in order to issue an MTC, or an ADCC for a Type Design Change, ◀ the MAA will expect to see the resultant residual Risk assessed and either mitigated to an ELOS or ► assessed against the Essential Requirements for Airworthiness to determine if a Deviation may be appropriate. Where this is not possible, then the MAA will consider issuing a Restricted MTC / ADCC provided that a level of Safety which is adequate with regard to the intended use can be demonstrated and that the increased RtL, when compared to compliance with the applicable Certification requirement is accepted by the relevant ADH. ◀ A process flowchart is shown at **Figure 5 – Compliance Flowchart** to aid TAAs in dealing with Certification non-compliances. ►◀

(1) ►◀

(2) ►◀

³⁰ Refer to [RA 5810\(7\)](#): Compliance with the Type Certification Basis (MRP Part 21.A.20).

► This Figure has been substantially rewritten. For clarity, no change marks are used ◄

Figure 5 – Compliance Flowchart

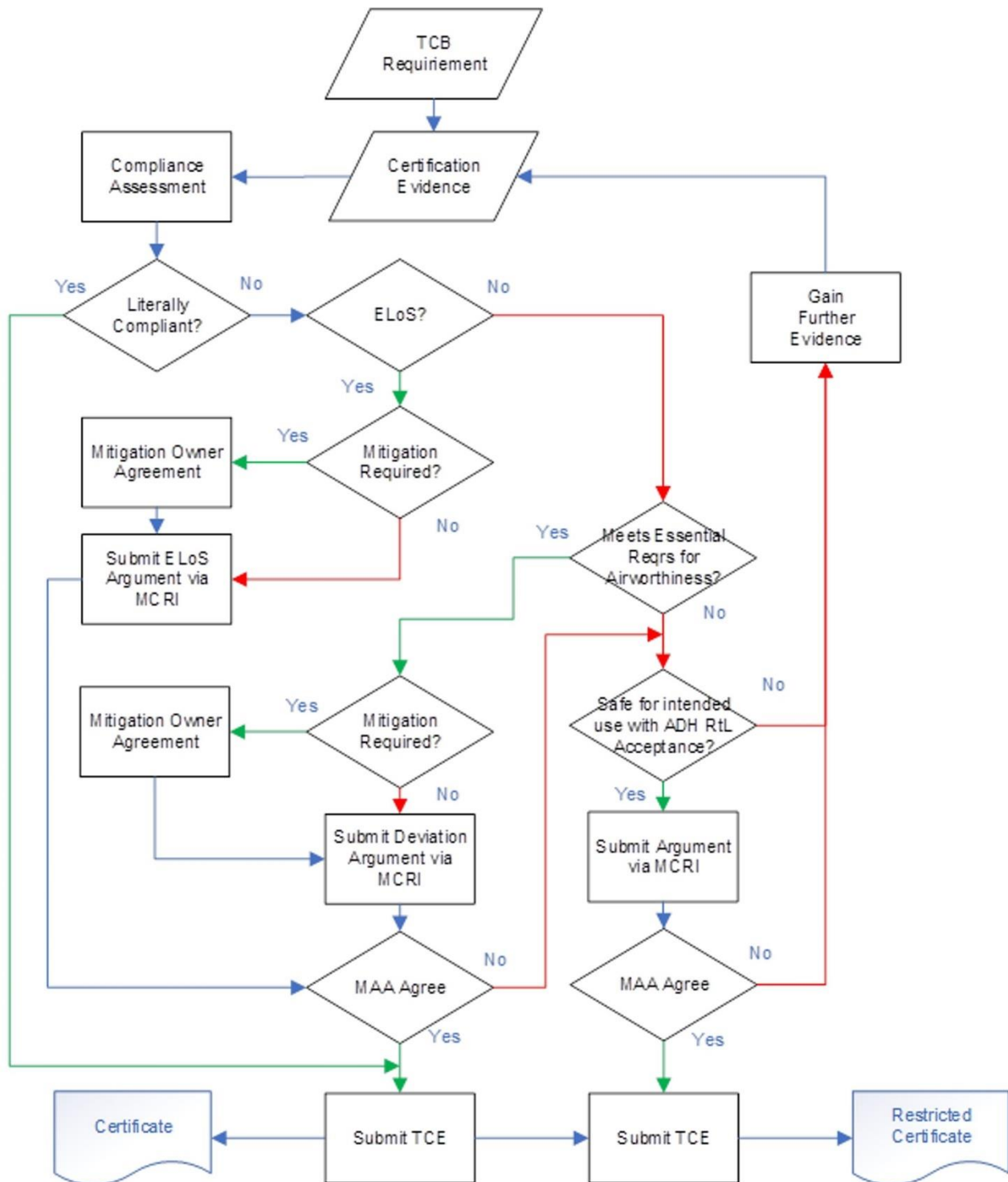

29. ► **Equivalent Safety Findings.** Means of reducing residual RtL to ELoS can either be achieved by the TAA through technical mitigation or by other operating mitigations such as procedures or training. It will be noted that ‘Equivalent’ is a deliberately absolute term and such mitigations will need to be demonstrated to be equally robust, under all anticipated operating conditions, as literal compliance with the Certification requirement. Where the TAA believes that an ELoS can be demonstrated, the E LoS proposal will be submitted to the MAA as a MCRI in order for the Authority to make an ESF, if appropriate. For any ELoS argument that requires controls,

factors, or mitigations that are outside of the TAA's AoR, the MAA will expect to see formal agreement by the mitigation owner, such as the Operating Authority or ADH; consequently, early engagement with the MAA over potential ELoS arguments is essential to avoid unnecessary rejection and rework. An ESF is considered a compliant outcome and would not preclude the award of an MTC / ADCC. For Minor Changes to Type Design, TAA's may approve ESFs on behalf of the MAA.

30. **Deviations.** Where literal compliance with a Certification requirement cannot be demonstrated, and AltMoC cannot be demonstrated to achieve the strict ELoS requirements, it may still be possible to demonstrate that the non-compliance does not result in a significant reduction in Airworthiness. Where it can be demonstrated that the Essential Requirements for Airworthiness have been satisfied, the MAA will consider issuing a Deviation which will describe how the AltMoC proposed by the Applicant meet the Essential Requirements for Airworthiness. It is implicit in this assessment that compliance with the Essential Requirements does not generate an elevated RtL when compared to literal compliance with the applicable Certification requirements. Therefore, ADH RtL acceptance is not required. However, as for an ELoS argument, endorsement by the appropriate owner of any operating controls, factors, or mitigations that are outside of the TAA's AoR will be required. A Deviation is considered a compliant outcome and would not preclude the award of an MTC / ADCC. The MAA application of the Deviation process is broadly similar to that employed by Civil Regulators but with some differences. For example, MAA Deviations are not subject to public consultation.

31. **Essential Requirements for Airworthiness.** Crewed aviation has only existed for a little over a century, yet the rapidly evolving design of Air Systems has led to increasingly complex Certification requirements to ensure Airworthiness through the safe design of Structure, Systems and propulsion which utilize new production methods, materials and design philosophies. However, despite this rapid evolution, there are a number of Essential Requirements for Airworthiness³¹ that have remained fundamental to safe design; these essential requirements are listed in [Annex A to Chapter 2](#).

32. **Adequate with Regard to the Intended Use.** The MAA recognizes that there may be circumstances where military imperative dictates that it is appropriate to introduce an Air System, or Type Design Change even where compliance with the Essential Requirements for Airworthiness cannot be fully demonstrated. In such cases, where the TAA is able to demonstrate that the Air System or Type Design Change delivers a level of Safety which is adequate with regard to the intended use, and the ADH is willing to accept that the elevated RtL is both As Low As Reasonably Practicable (ALARP) and Tolerable, the MAA will consider issuing a Restricted MTC or Restricted ADCC. The MTC / ADCC Restrictions will spell out those areas where the MAA is unable to assure that compliance with the TCB, including any ESFs or Deviations, has been demonstrated. Any RTS Limitations, necessary to ensure that the Air Systems remains safe with regard to the Intended Use will be included in the MTC / ADCC Restrictions. ◀

33. The extent to which the MAA will Audit the submitted evidence will be informed by both the extent of the 3rd party Assurance that the TAA has put in place and a broader Risk Assessment conducted by the MAA. TAAs will be expected to ensure the design is subject to independent technical evaluation and Audit²⁰, and DOs will be expected to have undertaken independent internal compliance verification¹⁴ of all evidence prior to submission. Where the Certification evidence does not demonstrate compliance with the TCB, a Restricted MTC (RMTC)³² may be issued.

34. Compliance document(s) referenced in the CP must ▶◀ include justifications of compliance, which must include as a minimum:

- a. The reference of the Certification Requirement or SC addressed by the document.
- b. Data demonstrating compliance.
- c. A statement by the TAA declaring that the document provides the proof of compliance

³¹ ▶ The CAA define these Product Integrity related Essential Requirements for Airworthiness within Annex II to [UK Regulation \(EU\) 2018/1139](#). Similar Essential Requirements covering Production and Organization Approvals are addressed elsewhere in the MRP. ◀

³² Refer to [RA 5810\(9\)](#): Issue of Restricted Military Type Certificate (MRP Part 21.A.21).

for which it has been created.

35. The MAA can provide guidance on circumstances where activities undertaken by other ► **Certification Authorities** ◀ may be claimed as [credit](#) towards demonstrating MACP compliance³³.

Phase 5 – MAA Review of Certification Evidence

36. **Review TCE and Produce TCR.** The MAA will review the TCE to provide independent Assurance that the Type Design has been shown to meet Airworthiness requirements through satisfactory completion of the MACP. The outcome of the MAA's analysis will be a formal TCR that will underpin the subsequent issue of an MTC or RMTC as appropriate.

37. **RTSR Assurance.** The initial [RTSR](#) must be submitted to the RTSA and the MAA³⁴. Access to the relevant [TASA](#)³⁵ and ADS will also be provided. For new Air Systems and Major changes that result in a new Mark Number for the Air System, the RTSR will be subject to independent Audit by the MAA. For all other Major changes, it will be decided by the MAA, in consultation with the RTSA and TAA, as to whether the MAA will carry out RTSR Assurance in addition to producing the TCR.

38. **Issue ► Certificate** ◀³⁶. A positive assessment of the RTSR and supporting documentation to the satisfaction of the MAA will result in the issue of an MTC. For new Air Systems this MTC covers the entire Air System, including engines and propellers (where applicable) and certifies that the Air System:

- a. Has been designed by an approved organization(s);
- b. Meets the approved TCB; ► ◀
- c. ► In cases in which the applicable TCB requirement cannot be literally complied with, either fully or in part, the MAA accepts a suitable alternative which provides an ELoS through the use of compensating factors; or
- d. The MAA accepts that AltMoC with the Essential Requirements for Airworthiness³⁷ have been demonstrated. ◀
- e. Is supported by appropriate RTSR, approved ADS containing instructions for safe operation and sustaining TAw and a comprehensive TASA.
- f. ► ◀

39. Where a military Air System is derived from a civil Type Design³⁸, the MTC may reference the civil TC to acknowledge credit awarded for existing Certification Assurance completed by another Regulator.

Phase 6 – Post Certification Activities

40. Following the Certification of a new Air System, or a Change to Type Design of an in-Service Air System, there will be on-going involvement from the MAA for several aspects of sustaining TAw, as follows:

- a. **MACP Actions.** Throughout a Certification project, the MAA will produce Actions that will need to be resolved at key points of the MACP (ie prior to RTSR submission, prior to MTC Approval etc). Some of these Actions may extend beyond initial RTS and therefore exist as [Restrictions](#) within the MTC or ADCC; consequently, the satisfactory completion of these MACP Actions will result in an uplift to those Certificates.
- b. **Major changes to the Type Design.** Throughout the life cycle of the Air System, there is likely to be a number of changes to Type Design, either through equipment Modifications or change of use, noting that each change to Type Design will invoke a new

³³ Refer to [Chapter 5](#) and the MMAR.

³⁴ Refer to ► [RA 1300 – Release to Service](#). ◀

³⁵ Refer to [RA 5012](#) – Type Airworthiness Safety Assessment.

³⁶ Refer to [RA 5810\(8\)](#): Issue of Military Type Certificate (MRP Part 21.A.21).

³⁷ ► Refer to [MMAC Annex A to Chapter 2](#). ◀

³⁸ For example: Embraer EMB-500 vs Phenom T Mk 1 and Grob 120TP vs Prefect T Mk 1.

MACP cycle.

- c. **Monitoring TAw.** This through-life activity could include Assurance activities such as:
- (1) Attendance at:
 - (a) TAw reviews.
 - (b) Safety meetings.
 - (c) Integrity Working Groups.
 - (2) Involvement in:
 - (a) Condition surveys and Ageing Air System Audits.
 - (b) MAA oversight and Assurance activities.

**Annex A to
Chapter 2****► Essential Requirements for Airworthiness**

1. **Product Integrity.** Product integrity, including protection against information security threats, must be assured for all anticipated flight conditions for the operational life of the Aircraft. Compliance with all requirements must be shown by assessment or analysis, supported, where necessary, by tests.
 - a. **Structures and materials.**
 - (1) The integrity of the Structure must be ensured throughout, and sufficiently beyond, the operational envelope for the Aircraft, including its Propulsion System, and maintained for the operational life of the Aircraft.
 - (2) All parts of the Aircraft, the failure of which could reduce the Structural Integrity, must comply with the following conditions without detrimental deformation or failure. This includes all items of significant mass and their means of restraint.
 - (a) All combinations of load reasonably expected to occur within and sufficiently beyond, the weights, centre of gravity range, operational envelope and life of the Aircraft must be considered. This includes loads due to gusts, manoeuvres, pressurisation, movable surfaces, control and Propulsion Systems both in flight and on the ground.
 - (b) Consideration must be given to the loads and likely failures induced by emergency landings either on land or water.
 - (c) As appropriate to the type of operation, dynamic effects must be covered in the structural response to those loads, taking into account the size and configuration of the Aircraft.
 - (3) The Aircraft must be free from any aero elastic instability and excessive vibration.
 - (4) The production processes and materials used in the construction of the Aircraft must result in known and reproducible structural properties. Any changes in material performance related to the operational environment must be accounted for.
 - (5) It must be ensured, to the extent practicable, that the effects of cyclic loading, environmental degradation, accidental and discrete source damage do not reduce the Structural Integrity below an acceptable residual strength level. All necessary instructions for ensuring continued Airworthiness in this regard must be promulgated.
 - b. **Propulsion**
 - (1) The integrity of the Propulsion System (ie engine and, where appropriate, propeller) must be demonstrated throughout and sufficiently beyond the operational envelope of the Propulsion System and must be maintained for the operational life of the Propulsion System, taking into account the role of the Propulsion System in the overall Safety concept of the Aircraft.
 - (2) The Propulsion System must produce, within its stated limits, the thrust or power demanded of it at all required flight conditions, taking into account environmental effects and conditions.
 - (3) The production process and materials used in the construction of the Propulsion System must result in known and reproducible structural behaviour. Any changes in material performance related to the operational environment must be accounted for.
 - (4) The effects of cyclic loading, environmental and operational degradation and likely subsequent part failures must not reduce the integrity of the Propulsion System below acceptable levels. All necessary instructions for ensuring continued Airworthiness in this regard must be promulgated.

- (5) All necessary instructions, information and requirements for the safe and correct interface between the Propulsion System and the Aircraft must be promulgated.
- c. Systems and equipment (other than non-installed equipment):
- (1) The Aircraft must not have design features or details that experience has shown to be hazardous.
- (2) The Aircraft, including those Systems, and equipment required for the assessment of the Type Design, or by operating rules, must function as intended under any foreseeable operating conditions, throughout and sufficiently beyond, the operational envelope of the Aircraft, taking due account of the system or equipment operating environment. Other Systems or equipment not required for type Certification, or by operating rules, whether functioning properly or improperly, must not reduce Safety and must not adversely affect the proper functioning of any other system or equipment. Systems and equipment must be operable without needing exceptional skill or strength.
- (3) The Aircraft Systems and equipment, considered separately and in relation to each other, must be designed such that any catastrophic failure condition does not result from a single failure not shown to be extremely improbable and an inverse relationship must exist between the probability of a failure condition and the severity of its effect on the Aircraft and its occupants. With respect to the single failure criterion above, it is accepted that due allowance must be made for the size and broad configuration of the Aircraft and that this may prevent this single failure criterion from being met for some parts and some Systems on helicopters and small Aircrafts.
- (4) Information needed for the safe conduct of the flight and information concerning unsafe conditions must be provided to the crew or Maintenance personnel, as appropriate, in a clear, consistent and unambiguous manner. Systems, equipment and controls, including signs and announcements must be designed and located to minimize errors which could contribute to the creation of Hazards.
- (5) Design precautions must be taken to minimize the Hazards to the Aircraft and occupants from reasonably probable threats, including information security threats, both inside and external to the Aircraft, including protecting against the possibility of a significant failure in, or disruption of, any non-installed equipment.
- d. Non-installed equipment
- (1) Non-installed equipment must perform its Safety function or function relevant for Safety as intended under any foreseeable operating conditions unless that function can also be performed by other means.
- (2) Non-installed equipment must be operable without needing exceptional skill or strength.
- (3) Non-installed equipment, whether functioning properly or improperly, must not reduce Safety and must not adversely affect the proper functioning of any other equipment, system or appliance.
- e. Continuing Airworthiness
- (1) All necessary documents including instructions for Continuing Airworthiness must be established and made available to ensure that the Airworthiness standard related to the Aircraft type and any associated part is maintained throughout the operational life of the Aircraft.
- (2) Means must be provided to allow inspection, adjustment, lubrication, removal or replacement of parts and non-installed equipment as necessary for Continuing Airworthiness.
- (3) The instructions for Continuing Airworthiness must be in the form of a manual, or manuals, as appropriate for the quantity of data to be provided. The manuals must

cover Maintenance and Repair instructions, servicing information, troubleshooting and inspection procedures, in a format that provides for a practical arrangement.

(4) The instructions for Continuing Airworthiness must contain Airworthiness limitations that set forth each mandatory replacement time, inspection interval and related inspection procedure.

2. **Airworthiness aspects of product operation.**

a. The following must be shown to have been addressed to ensure Safety for those on board or on the ground during the operation of the product:

(1) The kinds of operation for which the Aircraft is approved must be established and limitations and information necessary for safe operation, including environmental limitations and performance, must be established;

(2) The Aircraft must be safely controllable and manoeuvrable under all anticipated operating conditions including following the failure of one or, if appropriate, more Propulsion Systems, taking into account the size and configuration of the Aircraft. Due account must be taken of pilot strength, flight deck environment, pilot workload and other Human-Factor considerations and of the phase of flight and its duration;

(3) It must be possible to make a smooth transition from one flight phase to another without requiring exceptional piloting skill, alertness, strength or workload under any probable operating condition;

(4) The Aircraft must have such stability as to ensure that the demands made on the pilot are not excessive taking into account the phase of flight and its duration;

(5) Procedures for normal operations, failure and emergency conditions must be established;

(6) Warnings or other deterrents intended to prevent exceedance of the normal flight envelope, must be provided, as appropriate to the Aircraft type;

(7) The characteristics of the Aircraft and its Systems must allow a safe return from extremes of the flight envelope that may be encountered.

b. The operating limitations and other information necessary for safe operation must be made available to the crew members.

c. Product operations must be protected from Hazards resulting from adverse external and internal conditions, including environmental conditions.

(1) In particular, and as appropriate to the type of operation, no unsafe condition must occur from exposure to phenomena such as, but not limited to, adverse weather, lightning, bird strike, high frequency radiated fields, ozone, etc., reasonably expected to occur during product operation, taking into account the size and configuration of the Aircraft;

(2) Cabin compartments, as appropriate to the type of operations, must provide Passengers with suitable transport conditions and adequate protection from any expected Hazard arising in flight operations or resulting in emergency situations, including fire, smoke, toxic gases and rapid decompression Hazards, taking into account the size and configuration of the Aircraft. Provisions must be made to give occupants every reasonable chance of avoiding serious injury and quickly evacuating the Aircraft and to protect them from the effect of the deceleration forces in the event of an emergency landing on land or water. Clear and unambiguous signs or announcements must be provided, as necessary, to instruct occupants in appropriate safe behaviour and the location and correct use of Safety equipment. Required Safety equipment must be readily accessible;

(3) Crew compartments, as appropriate to the type of operations, must be arranged in order to facilitate flight operations, including means providing situational awareness, and management of any expected situation and emergencies. The environment of crew

compartments must not jeopardise the crew's ability to perform their tasks and its design must be such as to avoid interference during operation and misuse of the controls. ◀



Chapter 3: Changes in Type Design (MRP Part 21 Subpart D)

Introduction

1. During the life of an Air System there will be changes in the [Type Design](#). [RA 5810\(10\)](#)⁷ defines what constitutes the Type Design of an Air System; alteration to any data included within this scope is considered a change to the Type Design, irrespective of how that change is embodied³⁹. It is therefore important that any such changes meet appropriate Safety requirements to ensure the Airworthiness implications of the change are fully **▶ understood**. **◀** Consequently, such changes are subject to classification and Approval prior to the implementation of the change. This Chapter supports [RA 5820](#) which is the core Regulation for changes in Type Design.

2. **New vs Legacy Air Systems.** The MACP was introduced in 2011⁴⁰ and was not retrospective; as a result, many Air System Types were already in-Service and had not undergone Type Design Assurance by the MAA⁴¹. Consequently, the MAA needs to distinguish between Air Systems that have, and those that have not, received MAA MACP Type Design Assurance. Accordingly, successful completion of the MACP for a Major change to Type Design will normally result in an up-issue of the Air System’s MTC. However, for legacy Air Systems⁴², an ADCC for the Major change will be awarded⁴³ for the successful completion of the MACP; **Figure 6** refers.

Figure 6 – Major Change - MTC vs ADCC

	Into-Service	Major change
 <p>Legacy Air System ie those that are in-Service but have not been awarded an MTC</p>	<p>No MAA Certification (Although may have an MAA Statement of Type Design Assurance)</p>	<p>ADCC issued for first Major change and then up issued following each Major change</p>
 <p>Air System ie those that have been subject to the MACP prior to In-Service</p>	<p>MTC Issued</p>	<p>MTC up issued for each Major change</p>

Classification of Change

3. Classification of changes in Type Design as Minor or Major is required to determine the Approval and Assurance route to be followed in either [RA 5820\(3\)](#) or [RA 5820\(4\)](#) respectively. The need for MAA Assurance of the Certification of a Type Design change is related to the Airworthiness implications of that change, including any associated with integration of new equipment or capabilities into the baseline design of the Air System.

Criteria

4. [RA 5820\(1\)](#) identifies the criteria for the classification of changes in Type Design as Minor and Major. Specifically, a Minor change has no appreciable effect on the mass, balance, structural strength, reliability, operational characteristics, **▶ armament system**, **◀** or other characteristics affecting the Airworthiness of the Air System. All other changes are Major changes; examples of Major changes are shown at [Annex A](#). This Chapter is intended to provide guidance on what constitutes an ‘appreciable effect on Airworthiness’ of the Air System, where ‘Airworthiness’ is interpreted in the context of conformity with the Type Design and in a condition for safe operation.

³⁹ Where a Modification is required to embody a change to Type Design, the process to be followed, in addition to the requirements of this RA, is law [RA 5305](#) – In-Service Design Changes and the detailed management of the Type Design change is law [RA 5301](#) – Air System Configuration Management.

⁴⁰ MAA/RI/07/11 issued 31 Aug 11 (replaced by RA 1500 in Nov 14, subsequently replaced by RA 5810 in Aug 16) required Air systems that had not achieved MG by 1 Sep 11 to be subject to Full MACP. Those that had passed MG but not achieved RTS were to be subject to Tailored MACP.

⁴¹ For the purposes of this Manual and RAs 5810 / 5820, these Air Systems are termed ‘Legacy Air Systems’, ie those that are in Service but have not been awarded an MTC.

⁴² In the context of Air System Certification, a ‘Legacy Air System’ is one that is in-Service but has not been awarded an MTC.

⁴³ If the Air System already holds an extant ADCC for a previous Major change, the ADCC will be up issued with the details of the subsequent Major change.

5. A change to the Type Design is judged to have an appreciable effect on characteristics affecting the Airworthiness, and therefore will be classified Major, when one or more of the following conditions are met:

- a. Where the change requires an adjustment of the TCB; such as [SC](#) or [ESF](#), other than electing to comply with a later amendment to the Certification Specification [▶44◀](#).
- b. Where the TAA proposes a new interpretation of the Certification requirements that has not been published as AMC material or otherwise agreed with the MAA.
- c. Where the demonstration of compliance uses methods that have not been previously accepted as appropriate for the nature of the change.
- d. Where the extent of new substantiation data necessary to comply with the applicable Certification Requirements and the degree to which the original substantiation data has to be re-assessed and re-evaluated is considerable.
- e. The change alters either Airworthiness Limitations or Operating Limitations.
- f. Where the change introduces or affects functions where the failure effect is classified catastrophic or critical⁴⁵.
- g. The change involves multiple Systems and areas, eg as part of a mid-life update, capability sustainment programme or US-style block upgrade programme. [▶◀](#)
- h. The change involves any of the following:
 - (1) Structural changes to the [▶Air System◀](#) that could invalidate previous Airworthiness assessments, such as significant increases in [▶Air System◀](#) all up mass, manoeuvre limits or cleared life.
 - (2) Any Modification to the weapons release or firing system, other than Minor changes to the hardware installation such as the routing of the wiring.
 - (3) Changes essential to correct an unsafe condition.
- i. When Programmable Elements (PE) are used, account will be taken of the following guidelines:
 - (1) Where a [▶change is made to any PE, following an analysis of the change or a Change Impact Analysis \(CIA\)46,◀](#) the change will be classified as Major if any of the following apply:
 - (a) The PE determined to be Design Assurance Level (DAL) A or DAL B, iaw SAE ARP 4754A, is changed unless that change involves only a variation of a parameter value within a range already verified for the previous Certification standard agreed by the MAA, or:
 - (b) The PE, determined to be DAL C, is significantly changed, eg after a software re-engineering process accompanying a change of processor.
 - (c) The PE, determined to be DAL A, B or C, is upgraded from a lower DAL, or downgraded from a higher DAL.
 - (2) For Programmable Element(s) developed to guidelines other than Radio Technical Commission for Aeronautics (RTCA) DO-178C/ EUROCAE ED-12C⁴⁷ and DO-254/ EUROCAE ED-80⁴⁸ Design Assurance Levels, the TAA will assess changes iaw the intent of para (1) above.
 - (3) Where the PE Modification impacts the Airworthiness Security and the initial Cyber Security Vulnerability Analysis shows that, before the implementation of mitigation, there is a potential threat path that could lead to a Catastrophic or Critical

⁴⁴ [▶ By derogation, the TAA may approve an ESF on behalf of the MAA.◀](#)

⁴⁵ Refer to [RA 1210](#) – Ownership and Management of Operating Risk (Risk to Life) for definition of catastrophic and critical.

⁴⁶ [▶ Refer to EASA AMC-20 Amendment 23, AMC 20-115D, GM1 and AMC-152A, Para 5.9 for further guidance.◀](#)

⁴⁷ Refer to RTCA DO-178C Software Considerations in Airborne Systems and Equipment Certification.

⁴⁸ Refer to RTCA DO-254 Design Assurance Guidance for Airborne Electronic Hardware.

failure effect.

6. **Novel aspects.** The conditions listed above, in particular sub paras a through d, would mean that the use of novel technologies (such as multi-core processors) or novel methods of manufacture (such as Additive Manufacturing) would result in the design change being classified as Major. This is because the use of novel technologies can introduce increased Airworthiness Risk due to limited historical evidence of safe outcomes. ►◄
7. **► Additive Manufacture.** Whilst the use of Additive Manufacture (AM) is becoming more common in Aerospace, there are few recognized Standards and small differences in the manufacturing process have been proven to have a significant impact on material properties. To ensure that best practice is shared, the MAA, in common with civil Regulators, require to be involved in the Certification of components using AM. Where a Major Type Design Change would otherwise be considered Minor, the MAA LOI is likely to be limited to the agreement of an MCRI that demonstrates that the Organizations involved in the Design and Manufacture have the necessary competence and robust processes. Once approved, future applications that fall within the scope of the MCRI could be classified as Minor, subject to MAA agreement. TAAs are encouraged to see this involvement as an opportunity to benefit from the experience that the MAA has developed on this subject and certainly not as a barrier to the option of this technology.
8. Engagement with the Regulator will ensure the application of best practice and assist in the development of AMC for such technologies. **Figure 7** illustrates the process for the classification of design changes. ◄

► This Figure has been substantially rewritten. For clarity, no change marks are used ◀

Figure 7 – Change Classification Process

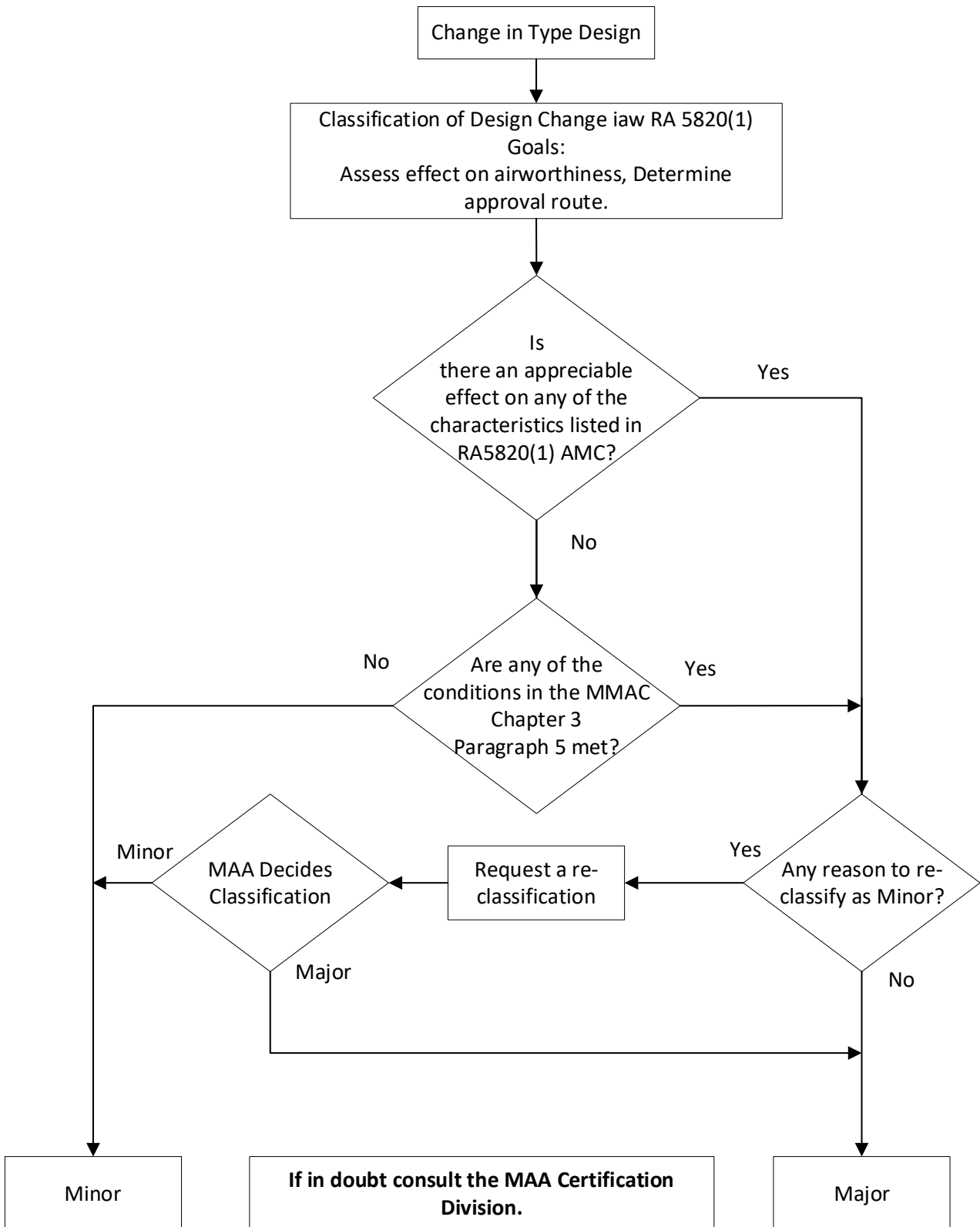

9. **Airworthiness Limitations.** The conditions listed ► in paragraph 5, ◀ in particular sub para e, would mean that, some changes to the ADS, and the ISTA specifically, would result in the design change being classified as Major. However, unlike ISTA for civil Aircraft, most military ADS do not contain a separate Airworthiness Limitations Section; accordingly, judgement will be

required to determine whether a change constitutes a change to an Airworthiness Limitation. In general, this will include:

- a. Mandatory Modification times.
- b. Replacement times.
- c. Inspection intervals and related inspection procedures.

Further detailed guidance of what constitutes the 'Airworthiness Limitations Section' may be found in [EASA CS 25 Appendix H Section H25.4](#) for Fixed Wing and [EASA CS29 Appendix A Section A29.4](#) for Rotary Wing.

10. **▶ Operating Limitations.** Operating Limitations are generally specified in the Release To Service (RTS), however, not all RTS entries are derived from the certification activities and qualify as Operating Limitations. Further detailed guidance of what constitutes the Operating Limitations may be found in [EASA CS 25.1501](#) for Fixed Wing and [EASA CS29.1501](#) for Rotary Wing.

11. **Minor Changes requiring no further demonstration of compliance.** There is a sub-set of the very simplest types of design changes for which full application of the MACP is neither practical nor proportionate. These changes are sometimes known colloquially as 'Minor-Minor Changes'. Such changes may be appropriately assured via Configuration Management processes under the control of the Local Technical Committee⁴⁹. Examples of such changes include:

- a. Design solutions that are so similar to existing ones that the validity of the original demonstration of compliance is not impacted.
- b. Typographical changes or added clarity to Instructions for Sustaining Airworthiness (ISTA).
- c. Alternative Part Numbers where there is no change to the fit, form or function of the original part. Note that this would not apply to changes requiring a change in specification or changes to more complex components.
- d. Changes for which there are no specific airworthiness requirements and / or environmental protection requirements related to the change. ◀

12. **Technical Standard Order (TSO).** Type Design changes may use articles approved⁵⁰ under a TSO or European TSO ((E)TSO). A TSO product has undergone limited Certification, by **▶ an authorized organization, ◀** against the Certification Specifications detailed in the applicable TSO. As such, a TSO will normally contain additional actions required to be undertaken in order to fully certify the product onto the Air System. A TSO product is supplied with a Declaration of Design Performance (DDP) that contains, amongst other items, a statement of compliance against the TSO, reference to relevant test reports and any acceptable **▶ departures ◀** from the TSO standard. A full review of the TSO standard and Certification evidence within the DDP is conducted by the TAA, against the agreed platform / change TCB, in order to identify non-compliances and understand the requirement for further testing, additional Safety Assessments and mitigations. Whilst Military TSO (MTSO) also exist, their use is not **▶ accepted ◀** by civil Regulators and thus their use during MACP will need careful consideration by the TAA, with early guidance sought from the MAA.

Substantial, Significant and Not-Significant Major Type Design Changes

13. A Major Type Design change is considered 'Substantial' if it is so extensive that a substantially complete investigation of compliance with the applicable TCB is required. A Substantial Change requires an application for a new MTC iaw RA 5810⁷. A Major Type Design change is considered 'Significant' if the change relates to one or more of the following: general configuration, principles of construction, or the assumptions used for Certification (including usage); otherwise, the change is considered 'Not Significant'. See also [Changed Product Rule](#).

14. International collaboration between several⁵¹ civil aviation authorities have resulting in tables

⁴⁹ ▶ Refer to [RA 5301 – Air System Configuration Management](#). ◀

⁵⁰ Refer to [RA 5875 – \(European\) Technical Standard Order \(MRP Part 21 Subpart O\)](#).

⁵¹ Specifically: EASA, FAA, Agência Nacional de Aviação Civil (ANAC - Brazil), and Transport Canada Civil Aviation (TCCA).

of 'Substantial', 'Significant', and 'Not Significant' Major changes being derived and adopted internationally⁵²; these tables are shown at [Annex A](#) to this Chapter, noting that the final classification may change due to cumulative effects and / or combinations of individual changes.

Cumulative Change Consideration

15. When identifying the change to Type Design, consideration will be given to any previous relevant changes that may contribute to a cumulative effect, as these may influence the classification decision of the change later in the process. Previous relevant changes are those design changes whose effects accumulate, such as; successive thrust increases, incremental mass increases, incremental PE changes or sectional increases in fuselage length. Any previous relevant Type Design changes in the area affected by the current change that did not involve an upgrade of the existing TCB will need to be considered in the next design change proposal.

16. An example of this would be a progressive increase in the Air System's all up mass (AUM); individually, the classification of each of these Major changes may be 'Not-Significant'. However, at some point, the cumulative effect of this series of mass increases on the Air System's Certification basis may be 'Significant', even if the last mass increase appears relatively small. For example, a proposed 5% mass increase appears to be Not-Significant, but a previous 10% and an earlier 15% mass increase has already been incorporated into this Air System without upgrading the existing TCB. Thus, the current proposal for a 5% mass increase actually results in a 30% AUM increase from the original TCB, for the purpose of making the classification decisions; thus, the final 5% change results in a 'Significant' Type Design change. Additionally, incremental amendments to the applicable Certification Specifications for Airworthiness may, together, cause a significant disparity with the extant TCB. Note that the cumulative effects to be considered are only those incremental increases from the last time the applicable Certification Specifications for Airworthiness in the TCB were upgraded.

Application for Change in Type Design

17. **MAA Form 30.** A MAA Form 30 will be raised on all Major Type Design Changes and submitted to the MAA. Whilst the TAA may propose assuring the Major change themselves, the MAA will review the MAA Form 30 and notify the TAA whether, or not, the Major change will be subject to MAA Certification Assurance activity (see Approval of Major Changes).

18. **Validity.** In line with applications for new Type Designs, the TCB for a change to Type Design only remains effective for 5 years from Form 30 submission; if Certification is not achieved within that timescale, a review of the Certification Specifications that underpin the TCB needs to be undertaken by the TAA in order to assess any shortfall against contemporary requirements.

19. **Operating Centre Director.** For Major Type Design changes that result in a new Mark Number for the Air System, the TCB must be proposed by the relevant DE&S Operating Centre Director²⁵ and agreed with the MAA prior to FBC (or equivalent) approval for the project.

Designation of Applicable Certification Specifications

20. When a product is changed, some areas may change physically, while others may change functionally; this is referred to as changed and affected areas. For example, an extension to the wing would physically change the wing tip and likely other wing structure. Some areas of the airframe may have sufficient strength for the increase in load and would change functionally, ie they would carry greater load, but they would not change physically. These areas have associated Certification specifications, which become part of the Certification basis for the change. The basic principle of enhancing the level of Safety of changed aeronautical products is to apply the latest Certification specifications for significant changes to the greatest extent practical. However, in certain cases, the cost of complying fully with a later Certification specification may not be commensurate with the small Safety benefit achieved. These factors form the basis where compliance with the latest standard may be considered impractical, thereby allowing compliance with an earlier Certification specification; this is the basis of the CPR.

⁵² Refer to EASA Part 21 (IR + AMC and GM) eRules (Dec 19) Appendix A to GM 21.A.101 Classification of design changes.

CPR

21. Whilst a change to Type Design will normally comply with Certification Specifications applicable on the date of application, the TAA can ►◄ comply with requirements from an earlier amendment of the Certification Specifications when one of the following apply:

- a. A change is either Minor or Not Significant⁵³.
- b. An area, system, part or appliance is not affected by the change.
- c. Compliance with the latest amendment for a Significant change does not contribute materially to the level of Safety.
- d. Compliance with the latest amendment would be impractical.

22. ► For Minor Changes, the TAA can determine the appropriate amendment to be applied iaw the CPR. For Major Changes, the TAA will propose the Certification Specification amendment on the MAA Form 30, for MAA agreement. ◄

23. **Figure 8** can be used to establish the TCB for changes in Type Design, in detailing evaluations, classifications, and decisions made throughout the process. If the TAA wishes to propose to use requirements from an earlier amendment of the Certification Specifications, they will need to show that:

- a. These earlier Certification Specifications are no earlier than the corresponding Certification Specifications of the original Type Design
- b. The changed product complies with these requirements and of any other requirement that is directly related.

⁵³ A change is considered Not Significant if it is neither Significant nor Substantial.

Figure 8 – Establishing the TCB for a Changed Product

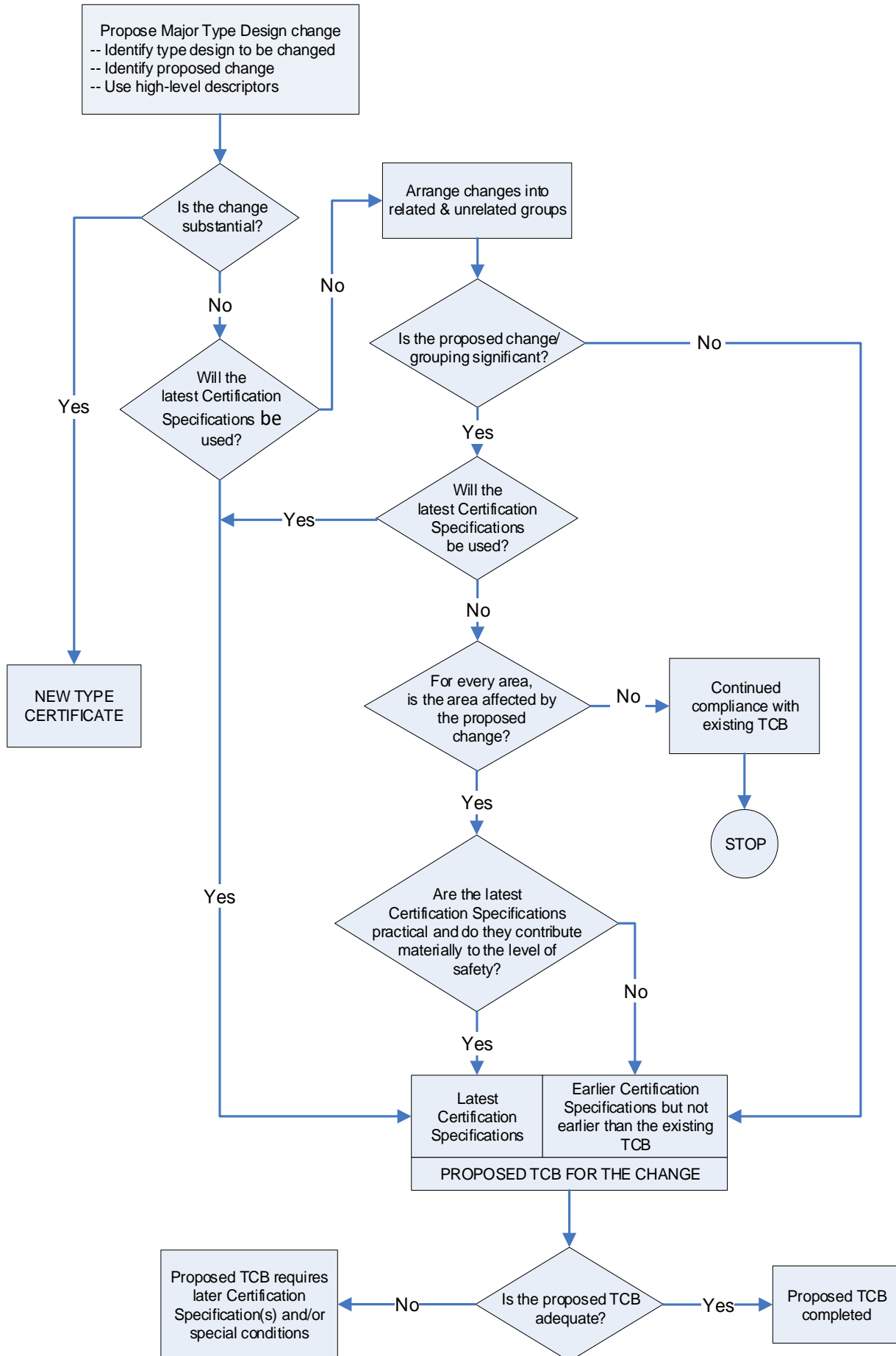

24. If a change introduces a feature that was not addressed in the previous issue of the Certification Specifications referenced in the original TCB, but is addressed in the current issue, then the current issue would be applicable.

25. However, when a proposed design change involves features or characteristics considered novel or unusual, or the intended use of the changed product is unconventional, or experience from other similar products in service or products having similar design features has shown that unsafe conditions may develop, and the proposed Certification Specifications do not contain adequate or appropriate standards for the changed product, later amendments and or [SC](#) will be applied.

Elect to Comply

26. If the TAA elects to comply with requirements that are derived from an amendment to a Certification Specifications that is effective after the submission of a MAA Form 30 for a change to a Type, the TAA will also need to comply with any other requirements that the MAA finds is directly related. However, note that the decision to comply with the latest requirements sets a new regulatory basis for all future related changes in the same affected area.

Special Conditions

27. If the MAA finds that the Certification Specifications referenced in the TCB do not provide adequate standards with respect to the proposed change, the TAA will also need to comply with any SC, and amendments to those SC, prescribed under the provisions of RA 5810, in order to provide a level of Safety comparable to that established in the Certification Specifications in effect at the date of the application for the change.

28. However, the application of SC, or for a change to existing SC, is not in itself a reason for the Type Design change to be classified as Substantial or Significant. When the change is Significant with earlier Certification requirements allowed through exceptions, or Not Significant, the level of Safety intended by the [SC](#) will be consistent with the agreed TCB.

Approval of Major Changes

29. Certification review activity by the MAA is a key Assurance tool to ensure that Major Changes to Type Design achieve appropriate Safety requirements. It provides a technical review of the Safety implications of the design change, independent from DT responsibilities, and allows the change to benefit from learning from other Certification projects. RTSAs and Operating Duty Holders (ODH) will make use of this work, in addition to the DT.

30. However, it is envisaged that only a proportion of Major Changes will be subject to independent MAA Assurance; this will depend upon a range of factors, centring on the nature and complexity of the change and the previous performance of the TAA, DT and DO. This approach is shown graphically at **Figure 9**.

Figure 9 – Design Change and Assurance Level

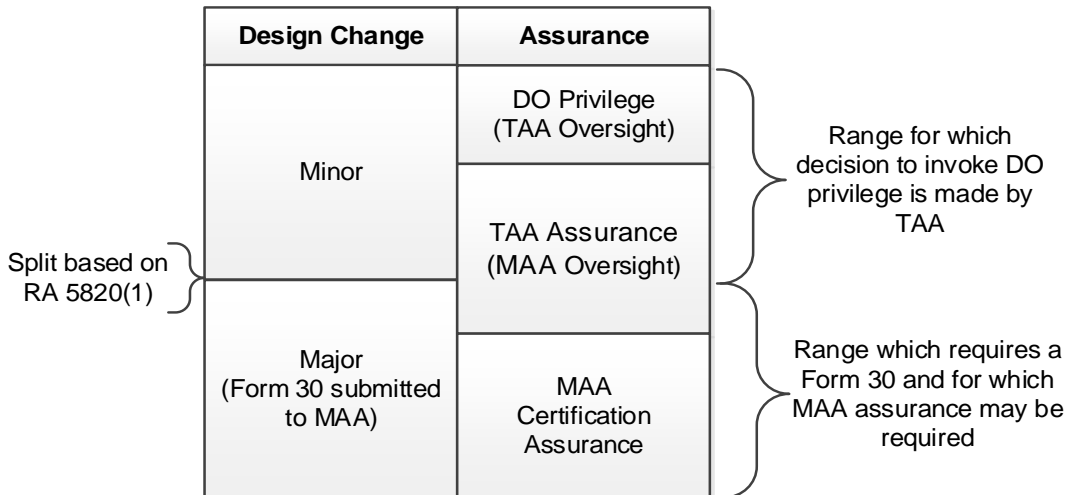

31. For Major Changes that result in a new Mark Number for the Air System, the RTSR will be subject to independent Assurance by the MAA. For all other Major Changes, it will be decided by the MAA, in consultation with the RTSA and TAA, as to whether, or not, the MAA will carry out a RTSR Audit. **► For Major Changes under TAA Assurance, if no MAA RTSR Audit is carried out, the TAA will be required to provide the document reference to the MAA to support the MAA’s uplift of the ADCC or MTC. ◀**

Issue of Approval

32. Successful completion of the MACP for a Major Change in Type Design will either result in the MAA up issuing the MTC or ADCC. However, the MAA will not issue a certificate until the Air System is brought UMC⁵⁴ unless the TAA can show how they intend to keep oversight of the Air System configuration such that changes to the configuration, including the need to update the ADS whilst Under Contractor Control, would not increase Risk.

33. If the MAA has chosen to assure the Major Change, the uplifted MTC or ADCC will be underpinned by the production of a TCR. **► For Major Changes under TAA Assurance, the TAA will ensure that their Certification of the change is appropriately recorded. AMC to RA 5820(4)⁵⁵ now explicitly requires the TAA to approve a TCE and provide the document reference to the MAA to support the MAA’s uplift of the ADCC or MTC. The TAA-approved TCE will summarise the outcome of MACP Phases 1-4 and will include the statements detailed in RA 5810(7)³⁰ AMC.**

34. The Major Change TCE and TCR will provide the supporting evidence for both the RTSR and TASA supporting the Air System Safety Case.

Non-compliances⁵⁶

35. Further to the guidance of the management of non-compliances in Chapter 2 paragraph 28, for Type Design changes, the following needs to be considered:

- a. **Minor Type Design Changes.** Type Design changes classified as Minor have no appreciable effect on the mass, balance, structural strength, operational characteristics, armament system, or other characteristics affecting the Airworthiness of the Air System; this includes adjustments to TCB or non-standard methods of compliance. Therefore, Assurance of Minor Changes by either the TAA or an approved DO under the privilege procedure is predicated on there being no non-compliances with the applicable TCB requirements. However, by derogation, providing they are content that there is no appreciable effect on Airworthiness, TAAs can approve ESF for Minor changes and must subsequently notify the MAA. However, where an ESF cannot be made, the MAA must agree acceptance of the non-compliance, via MCRI, before the change can be certified.

⁵⁴ ► Refer to RA 5301 – Air System Configuration Management.

⁵⁵ Refer to RA 5820(4): Approval of Major Changes (MRP Part 21.A.97).

⁵⁶ Refer to RA 5820(4) AMC. ◀

- b. **Minor Type Design Changes under Design Organisation Privileges.** The MAA derogation that allows TAAs to approve ESFs for Minor changes does not extend to approved DOs acting under privilege. If a non-compliance is identified for a change being certified under privilege, the DO will need to inform the TAA who will determine whether an ESF can be issued or if re-classification of the change to Major is appropriate.
- c. **Major (TAA-Assured) Type Design Changes.** The MAA can permit TAA Assurance of Major Type Design changes where it is assessed that the nature and complexity of the change, and the previous performance of the TAA / DT / DO, justifies such a decision. Therefore, permitting TAA Assurance is predicated on there being no non-compliances with the applicable TCB requirements. Accordingly, any non-compliances and proposed Alternative Means of Compliance (AltMoC), Special Conditions, ESFs or Deviations encountered during the MACP need to be staffed to the MAA through MCRI(s), prior to approval of the Change. As part of their review, the MAA will consider whether the non-compliance requires a change to the previously agreed MAA LOI. ◀

Major Type Design Change Examples

1. A Major change is one that has an appreciable effect on the mass, balance, structural strength, reliability, operational characteristics ► **armament systems**, ◀ or other characteristics affecting the Airworthiness of the Air System. The examples provided below are identified by discipline and are applicable to all products (Aircraft, engines and propellers). However, a particular change may involve more than one discipline, eg a change to engine controls may be covered in engines and systems (software). Accordingly, personnel classifying design changes are to be aware of the interaction between disciplines and the consequences this will have when assessing the effects of a change (ie operations and Structures, Systems and structures, Systems and Systems, etc).

2. Major design changes are further sub-divided into Substantial, Significant and Not-Significant; examples of these are shown at Table 4.

a. Structure.

(1) Changes such as a cargo door cut-out, fuselage plugs, change of dihedral, addition of floats.

(2) Changes to materials, processes or methods of manufacture of primary structural elements, such as spars, frames and critical parts.

(3) Changes that adversely affect fatigue or damage tolerance or life limit characteristics.

(4) Changes that adversely affect aero-elastic characteristics.

(5) Changes that affect primary structural element loads and their path.

b. Cabin Safety.

(1) Changes which introduce a new cabin layout of sufficient change to require a re-assessment of emergency evacuation capability, or which adversely affect other aspects of passenger or crew Safety. Items to consider include, but are not limited to:

(a) Changes to or introduction of dynamically tested seats.

(b) Change to the pitch between seat rows.

(c) Change of distance between seat and adjacent obstacle like a divider.

(d) Changes to cabin lay outs that affect evacuation path or access to exits.

(e) Installation of new galleys, toilets, wardrobes, etc.

(f) Installation of new type of electrically powered galley insert.

(2) Changes to the pressurisation control system which adversely affect previously approved limitations.

c. Flight.

(1) Changes which adversely affect the approved performance, such as high altitude operation, brake changes that affect braking performance, deck landing, operation with night vision devices, air to air refuelling, low level flight.

(2) Changes which adversely affect the flight envelope.

(3) Changes which adversely affect the handling qualities of the product including changes to the flight control function (gains adjustments, functional Modification to software) or changes to the flight protection or warning system.

d. Systems.

(1) For Systems assessed under the applicable Airworthiness requirements the

classification process is based on the functional aspects of the change and its potential effects on Safety.

(2) Where the failure effect is catastrophic or critical, the change is to be classified as ►a◀ Major ►Change◀.

(3) Where the failure effect is 'major', the change is to be classified as ►a◀ Major ►Change◀ if:

(a) Aspects of the compliance demonstration, use means or methods that have not been previously accepted for the nature of the change to the system; or

(b) The change affects the pilot system interface (displays, controls, approved procedures); or

(c) The change introduces new types of functions or systems such as Global Positioning Systems primary, Terrain Collision Avoidance Systems, Predictive windshear, Head-Up Displays.

(4) The assessment of the criteria for Programmable Element changes to Systems also needs to be performed; account is to be taken also of the following guidelines:

(a) Where a change is made to software produced iaw the guidelines of RTCA DO-178C "Software Considerations in Airborne Systems and Equipment Certification", the change is to be classified as ►a◀ Major ►Change◀ if either of the following apply, and the failure effect is catastrophic or critical:

i. The executable code for software, determined to be Level A or Level B iaw the guidelines, is changed unless that change involves only a variation of a parameter value within a range already verified for the previous Certification standard; or

ii. The software is upgraded to or downgraded from Level A, Level B or Level C; or

iii. The executable code, determined to be level C, is deeply changed, eg after a software reengineering process accompanying a change of processor.

(b) For software developed to guidelines other than RTCA DO-178C Design Assurance Levels, the Applicant is to assess changes iaw the foregoing principles, giving due consideration to specific requirements or interpretations.

e. **Propellers.**

Changes to:

(1) Diameter.

(2) Aerofoil.

(3) Planform.

(4) Material.

(5) Blade retention system, etc.

f. **Engines.**

Changes:

(1) That adversely affect operating speeds, temperatures, and other limitations.

(2) That affect or introduce parts (as identified by the applicable Airworthiness requirements) where the failure effect has been shown to be catastrophic or critical.

(3) That affect or introduce engine critical parts (as identified by the applicable Airworthiness requirements) or their life limits.

(4) To a structural part which requires a re-substantiation of the fatigue and static

load determination used during Certification.

(5) To any part of the engine which adversely affects the existing containment capability of the structure.

(6) That adversely affect the fuel, oil and Air Systems, which alter the method of operation, or require reinvestigation against the TCB.

(7) That introduce new materials or processes, particularly on critical components.

g. **Rotors and Drive Systems.**

Changes that:

(1) Adversely affect fatigue evaluation unless the service life or inspection interval are unchanged. This includes changes to materials, processes or methods of manufacture of parts, such as:

- (a) Rotor blades.
- (b) Rotor hubs including dampers and controls.
- (c) Gears.
- (d) Drive shafts.
- (e) Couplings.

(2) Affect systems the failure of which may have catastrophic or critical effects. The design assessment will include:

- (a) Cooling system.
- (b) Lubrication system.
- (c) Rotor controls.

(3) Adversely affect the results of the rotor drive system endurance test.

(4) Adversely affect the results of the shafting critical speed analysis.

h. **Power plant Installation.**

Changes which include:

- (1) Control system changes which affect the engine or propeller or airframe interface.
- (2) New instrumentation displaying operating limits.
- (3) Modifications to the fuel system and tanks (number, size and configuration).
- (4) Change of engine or propeller type.

i. **Operational characteristics.**

Integration or Modification of mission equipment that could adversely affect Safety of third parties include, but are not limited to, the following:

- (1) Installation of in-flight refuelling capabilities.
- (2) Installation of new external tanks.
- (3) Installation of new weapons and stores.
- (4) Installation of new equipment that may affect Electromagnetic Environmental Effects integrity (eg new radar) installation of aerial delivery systems.
- (5) Installation of flare and chaff system.
- (6) Installation of systems integrating a high-power laser.
- (7) Modification to the release device of a jettisoning tank.

Table 4 – Examples of Substantial, Significant and Not Significant Changes⁵⁷

Description of Change	General configuration changed?	Principles of construction changed?	Certification assumptions invalidated?	Notes
Fixed-Wing				
Substantial				
Change to wing location (tandem, forward, canard, high / low).				Proposed change to design is so extensive that a substantially complete investigation of compliance with the applicable Certification basis is required.
Change of empennage configuration for larger aircraft's (cruciform vs 'T' or 'V' tail).				
Change to the number or location of engines, eg four to two wing-mounted engines or two wing-mounted to two body-mounted engines.				
Replacement of piston or turboprop engines with turbojet or turbofan engines.				
Change to engine configuration (tractor / pusher).				
Increase from subsonic to supersonic flight regime.				
Change from an all-metal to all-composite aircraft.				
Certifying a CS-23 (or predecessor basis, such as JAR-23) aircraft into another Certification category, such as CS-25.				
Significant				
Conventional tail to T-tail or V-tail, or vice versa.	Yes	No	Yes	Change to general configuration. Requires extensive, structural flying qualities and performance reinvestigation. Requires new Aircraft Flight Manual (AFM) to address performance and flight characteristics.
Changes to wing configuration, such as change to dihedral, changes to wingspan, flap or aileron span, addition of winglets, or increase of more than 10% of the original wing sweep at the quarter chord.	Yes	No	Yes	Change to general configuration. Likely requires extensive changes to wing structure. Requires new AFM to address performance and flight characteristics. Note: Small changes to the wingtip or winglet are not significant changes. See table for 'not significant' changes.
Changes to tail configuration, such as the addition of tail strakes or angle of incidence of the tail.	Yes	No	Yes	Change to general configuration. Likely requires extensive changes to tail structure. Requires new AFM to address performance and flight characteristics. Note: Small changes to tail are not significant changes.
Tricycle / tail wheel undercarriage change or addition of floats.	Yes	No	No	Change to general configuration. Likely, at aircraft level, general configuration and Certification assumptions remain valid.
Passenger-to-freighter configuration conversion that involves the introduction of a cargo door or an increase in floor loading of more than 20%, or provision for carriage of passengers and freight together.	Yes	No	Yes	Change to general configuration affecting load paths, aeroelastic characteristics, Aircraft-related systems, etc. Change to design assumptions.
Replace reciprocating engines with the same number of turbopropeller engines.	Yes	No	No	Requires extensive changes to airframe Structure, addition of Aircraft systems, and new AFM to address performance and flight characteristics.
Addition of a turbocharger that changes the power envelope, operating range, or limitations.	No	No	Yes	Invalidates Certification assumptions due to changes to operating envelope and limitations. Requires new AFM to address performance and flight characteristics.
The replacement of an engine of higher rated power or increase thrust would be considered significant if it would invalidate the existing substantiation, or would change the primary structure, aerodynamics, or operating envelope sufficiently to invalidate the assumptions of Certification.	No	Yes	Yes	Invalidates Certification assumptions. Requires new AFM to address performance and flight characteristics. Likely changes to primary structure. Requires extensive construction reinvestigation.
A change to the type of material, such as composites in place of metal, or one composite fibre material system with another (eg carbon for fiberglass), for primary Structure would normally be assessed as a significant change.	No	Yes	Yes	Change to principles of construction and design from conventional practices. Likely change to design / Certification assumptions.
10. A change involving appreciable increase in	No	No	Yes	Certification assumptions invalidated. Requires new

⁵⁷ Adapted from Tables within [EASA - Easy Access Rules for Airworthiness and Environmental Certification](#).

Description of Change	General configuration changed?	Principles of construction changed?	Certification assumptions invalidated?	Notes
design speeds V^D , V^B , V^{MO} , V^C , or V^A .				AFM to address performance and flight characteristics.
Installation of a short take-off and landing (STOL) kit.	No	No	Yes	Certification assumptions invalidated. Requires new AFM to address performance and flight characteristics.
A change to the rated power or thrust could be a significant change if the TAA is taking credit for increased design speeds per example 10 of this table.	No	No	Yes	Certification assumptions invalidated. Requires new AFM to address performance and flight characteristics.
Fuel state, such as compressed gaseous fuels or fuel cells. This could completely alter the fuel storage and handling systems and possibly affect the aircraft structure.	No	No	Yes	Changes to design / Certification assumptions. Extensive alteration of fuel storage and handling systems.
A change to the flight control concept for an Aircraft, eg to fly-by-wire (FBW) and side-stick control, or a change from hydraulic to electronically actuated flight controls, would in isolation normally be regarded as a significant change.	No	No	Yes	Changes to design and Certification assumptions. Requires extensive systems architecture and integration reinvestigation. Requires new AFM.
Change to aircraft's operating altitude, or cabin operating pressure greater than 10% in maximum cabin pressure differential.	No	No	Yes	This typically invalidates Certification assumptions and the fundamental approach used in decompression, structural strength, and fatigue. May require extensive airframe changes affecting load paths, fatigue evaluation, aeroelastic characteristics, etc. Invalidates design assumptions.
Addition of a cabin pressurisation system.	No	Yes	Yes	Extensive airframe changes affecting load paths, fatigue evaluation, aeroelastic characteristics, etc. Invalidates design assumptions.
Changes to types and number of emergency exits or an increase in maximum certified passenger capacity.	Yes	No	Yes	Emergency egress Certification specifications exceed those previously substantiated. Invalidates assumptions of Certification.
A change to the required number of flight crew that necessitates a complete flight deck rearrangement, and / or an increase in pilot workload.	No	No	Yes	Extensive changes to avionics and Aircraft systems. Invalidates Certification assumptions. Requires new AFM.
Expansion of an Aircraft's operating envelope.*	No	No	Yes*	An expansion of operating capability is a significant change (eg an increase in maximum altitude limitation, Approval for flight in icing conditions, or an increase in airspeed limitations). *Some changes may be deemed 'not significant' depending on the extent of the expansion
Replacement of an aviation gasoline engine with an engine of approximately the same horsepower utilising, eg diesel, hybrid, or electrical power.	No	No	Yes	A Major change to the aircraft. The general configuration and principles of construction will usually remain valid; however, the assumptions for Certification are invalidated.
Comprehensive flight deck upgrade, such as conversion from entirely federated, independent electromechanical flight instruments to highly integrated and combined electronic display systems with extensive use of software and / or complex electronic hardware.	No	No	Yes	Affects avionics and electrical systems integration and architecture concepts and philosophies. This drives a reassessment of the human-machine interface, flight-crew workload, and re-evaluation of the original design flight deck assumptions.
Conversion from a safe life design to a damage tolerance-based design.	No	No	Yes	Where the airframe-established safe life limits change to damage-tolerance principles, then use of an inspection program in lieu of the safe life design limit invalidates the original assumptions used during Certification.
Extensive structural airframe Modification, such as a large opening in the fuselage.	Yes	No	No	Requires extensive changes to fuselage structure, affects Aircraft systems, and requires a new AFM to address performance and flight characteristics.
Fuselage stretch or shortening in the cabin or pressure vessel.	Yes	No	Yes	Cabin interior changes are related changes since occupant Safety considerations are impacted by a cabin length change. Even if a new cabin interior is not included in the product-level change, the functional effect of the fuselage plug has implications on occupant Safety (eg the dynamic environment in an emergency landing, emergency evacuation, etc), and thus the cabin interior becomes an affected area.
Conversion from normal category to commuter category aircraft.	Yes	No	Yes	Requires compliance with all commuter regulatory standards. In many cases, this change could be

Description of Change	General configuration changed?	Principles of construction changed?	Certification assumptions invalidated?	Notes
				considered a substantial change to the Type Design. Therefore, a proposed change of this nature would be subject to EASA determination under 21.A.19.
Installation of a full authority digital engine control (FADEC) on an aircraft that did not previously have a FADEC installed.	No	No	Yes	—
Modify an aircraft to add Certification for flight in icing conditions by adding systems, such as ice detection and ice protection.	Yes	No	Yes	New Aircraft operating envelope. Requires major new Systems installation and Aircraft evaluation. Operating envelope changed.
Addition of leading-edge slats.	Yes	No	Yes	The addition of leading-edge slats is significant since it requires extensive changes to wing structure, adds Aircraft systems, and requires a new AFM to address performance and flight characteristics.
Changing the number of axles or number of landing gear done in context with a product change that involves changing the aircraft's gross weight.	Yes	No	No	This type of landing gear change with an increase in gross weight is significant since it requires changes to Aircraft structure, affects Aircraft systems, and requires AFM changes, which invalidate the Certification assumptions.
An increase in design weight of more than 10%.	No	No	Yes	Design weight increases of more than 10% result in significant design load increase that invalidates the assumptions used for Certification, requiring re-substantiation of Aircraft Structure, Aircraft performance, and flying qualities and associated Systems.
Installation of winglets, Modification of existing winglets, or other changes to wing tip design.	Yes	No	Yes	Significant if it requires extensive changes to wing Structure or Aircraft systems, or if it requires a new AFM to address performance and flight characteristics. It may also affect the wing fuel tanks, including fuel tank lightning protection, fuel tank ignition source prevention, and fuel tank flammability exposure.
An avionics upgrade that changes the method of input from the flight crew, which was not contemplated during the original Certification.	No	No	Yes	A change that includes touchscreen technology typically does not invalidate the assumptions used for Certification. A change that incorporates voice-activated controls or other novel human-machine interface would likely invalidate the assumptions used for Certification.
Replace reciprocating with turbo-propeller engines.	Yes	No	No	Requires extensive changes to airframe Structure, addition of Aircraft systems, and new AFM to address performance and flight characteristics.
Maximum continuous or take-off thrust or power increase of more than 10% or, for turbofans, an increase of the nacelle diameter.	No	No	Yes	A thrust or power increase of more than 10% is significant because it does have a marked effect on Aircraft performance and flying qualities or requires re-substantiation of powerplant installation. An increase of the nacelle diameter as a result of an increase in the bypass ratio is significant because it results in airframe-level effects on Aircraft performance and flying qualities. However, a small increase of the nacelle diameter would not have such an airframe-level effect and would not be considered a significant change.
Initial installation of an autoland system.	No	No	Yes	Baseline aircraft not designed for autoland operation, potential flight-crew workload, and systems compatibility issues.
Installation of a new fuel tank, eg installation of an auxiliary fuel tank in a cargo bay or installation of an auxiliary fuel tank that converts a dry bay into a fuel tank (such as a horizontal stabiliser tank).	No	No	Yes	Requires changes to airframe, systems, and AFM. Results in performance changes. These changes typically affect fuel tank lightning protection, fuel tank ignition source prevention, and fuel tank flammability exposure.
Initial installation of an APU essential for Aircraft flight operation.	No	No	Yes	Changes to emergency electrical power Certification specifications, change to Aircraft flight manual and operating characteristics.
Conversion from hydraulically actuated brakes to electrically actuated brakes.	No	No	Yes	Assumptions of Certification for aircraft performance are changed.
Installation of engine thrust reversers.	Yes	No	Yes	
Request for Extended Range Operations (ETOPS) Type Design Approval for: (a) aircrafts without an existing ETOPS Type Design Approval, and (b) extension of an aircraft's diversion time.	No	No	Yes	An expansion of diversion capability for ETOPS would normally be a significant change. However, expanding the diversion capability for which it was originally designed is generally not a significant change. In this case, the assumptions used for

Description of Change	General configuration changed?	Principles of construction changed?	Certification assumptions invalidated?	Notes
				Certification of the basic product remain valid, and the results can be applied to cover the changed product with predictable effects or can be demonstrated without significant physical changes to the product.
Not-Significant				
Addition of wingtip Modifications (not winglets).	No	No	No	A Major change to the aircraft. Likely, the original general configuration, principles of construction, and Certification assumptions remain valid.
Installation of skis or wheel skis.	No	No	No	Although a Major change to the aircraft, likely the original general configuration, principles of construction, and Certification assumptions remain valid.
Forward looking infrared (FLIR) or surveillance camera installation.	No	No	No	Additional flight or structural evaluation may be necessary, but the change does not alter basic aircraft Certification.
Litter, berth, and cargo tie down device installation.	No	No	No	Not an aircraft-level change.
Replacement of one propeller type with another (irrespective of increase in number of blades).	No	No	No	Although a Major change to the aircraft, likely the original general configuration, principles of construction, and Certification assumptions remain valid.
Addition of a turbocharger that does not change the power envelope, operating range, or limitations (eg a turbo-normalised engine, where the additional power is used to enhance high-altitude or hot-day performance).	No	No	No	Not an aircraft-level change.
Substitution of one method of bonding for another (eg change to type of adhesive).	No	No	No	Not an aircraft-level change.
Substitution of one type of metal for another.	No	No	No	Not an aircraft-level change.
Any change to construction or fastening not involving primary structure.	No	No	No	Not an aircraft-level change.
A new fabric type for fabric-skinned Aircraft.	No	No	No	Not an aircraft-level change.
Increase in flap speed or undercarriage limit speed.	No	No	No	Although a Major change to the aircraft, likely the original general configuration, principles of construction, and Certification assumptions remain valid.
Structural strength increases.	No	No	No	Although a Major change to the aircraft, likely the original general configuration, principles of construction, and Certification assumptions remain valid.
Instrument flight rules (IFR) upgrades involving installation of components (where the original Certification does not indicate that the aircraft is not suitable as an IFR platform, eg special handling concerns).	No	No	No	Not an aircraft-level change.
Fuel tanks where fuel is changed from gasoline to diesel fuel and tank support loads are small enough that an extrapolation from the previous analysis would be valid. Chemical compatibility would have to be substantiated.	No	No	No	Not an aircraft-level change.
Limited changes to a pressurisation system, eg number of outflow valves, type of controller, or size of pressurised compartment, but the system must be resubstantiated if the original test data are invalidated.	No	No	No	Although a Major change to the aircraft, likely the original general configuration, principles of construction, and Certification assumptions remain valid.
Install a different exhaust system.	No	No	No	Not an aircraft-level change.
Changes to engine cooling or cowling.	No	No	No	Not an aircraft-level change.
Changing fuels of substantially the same type, such as AvGas to AutoGas, AvGas (80/87) to AvGas (100LL), ethanol to isopropyl alcohol, Jet B to Jet A.	No	No	No	Although a Major change to the aircraft, likely the original general configuration, principles of construction, and Certification assumptions remain valid.
Fuels that specify different levels of 'conventional' fuel additives that do not change the primary fuel type. Different additive levels (controlled) of MTBE, ETBE, ethanol, amines, etc., in AvGas would not be considered a significant change.	No	No	No	Although a Major change to the aircraft, likely the original general configuration, principles of construction, and Certification assumptions remain valid.
A change to the maximum take-off weight of less than 5%, unless assumptions made in	No	No	No	Although a Major change to the aircraft, likely the original general configuration, principles of

Description of Change	General configuration changed?	Principles of construction changed?	Certification assumptions invalidated?	Notes
justification of the design are thereby invalidated.				construction, and Certification assumptions remain valid.
An additional aileron tab (eg on the other wing).	No	No	No	Although a Major change to the aircraft, likely the original general configuration, principles of construction, and Certification assumptions remain valid.
Larger diameter flight control cables with no change to routing, or other system design.	No	No	No	Not an aircraft-level change.
Autopilot installation (for IFR use, unless the original Certification indicates that the aircraft is not suitable as an IFR platform).	No	No	No	Although a Major change to the aircraft, likely the original general configuration, principles of construction, and Certification assumptions remain valid.
Increased battery capacity or relocate battery.	No	No	No	Not an aircraft-level change.
Replace generator with alternator.	No	No	No	Not an aircraft-level change.
Additional lighting (eg navigation lights, strobes).	No	No	No	Not an aircraft-level change.
Higher capacity brake assemblies.	No	No	No	Not an aircraft-level change.
Increase in fuel tank capacity.	No	No	No	Not an aircraft-level change.
Addition of an oxygen system.	No	No	No	Not an aircraft-level change.
Relocation of a galley.	No	No	No	Not an aircraft-level change.
Passenger-to-freight (only) conversion with no change to basic fuselage structure.	No	No	No	Although a Major change to the aircraft, likely the original general configuration, principles of construction, and Certification assumptions remain valid. Requires Certification substantiation applicable to freighter Certification specifications.
New cabin interior with no fuselage length change.	No	No	No	—
Installation of new seat belt or shoulder harness.	No	No	No	Not an aircraft-level change.
A small increase in centre of gravity (CG) range.	No	No	No	At aircraft level, no change to general configuration, principles of construction, and Certification assumptions.
Auxiliary power unit (APU) installation that is not flight essential.	No	No	No	Although a Major change to the aircraft level, likely the original general configuration, principles of construction, and Certification assumptions remain valid. Requires Certification substantiation applicable to APU installation Certification specifications.
An alternative autopilot.	No	No	No	Not an aircraft-level change.
Addition of Class B terrain awareness and warning system (TAWS).	No	No	No	Not an aircraft-level change.
Extending an established life limit.	No	No	No	This extension may be accomplished by various methods, such as ongoing fatigue testing, service life evaluation, component level replacement, and inspections based on damage-tolerance principles.
Flight deck replacement of highly integrated and combined electronic display systems with other highly integrated and combined electronic display systems.	No	No	No	Not significant if the architecture concepts, design philosophies, human-machine interface, or flight-crew workload assumptions are not impacted.
Interior cabin reconfigurations are generally considered not significant. This includes installation of in-flight entertainment (IFE), new seats, and rearrangement of furniture.	No	No	No	—
Modification to ice protection systems.	No	No	No	Recertification required, but Certification basis will need to be evaluated for adequacy.
Alternate engine installation or hush kit at same position.	No	No	No	It is not significant so long as there is less than a 10% increase in thrust or there is not a change to the principles of propulsion. A change to position to accommodate a different engine size could influence aircraft performance and handling qualities and result in a significant change.
A small change to fuselage length due to refairing the aft body or radome.	No	No	No	For cruise performance reasons, where such changes do not require extensive structural, systems, aerodynamic, or AFM changes.
Re-fairing of wing tip caps (for lights, fuel dump pipes) and addition of splitter plates to the trailing edge thickness of the cruise aerofoil.	No	No	No	Does not require extensive structural, AFM, or systems changes.
Change from assembled primary Structure to monolithic or integrally machined structure.	No	No	No	Method of construction must be well understood.
Brakes: design or material change, eg steel to carbon.	No	No	No	Recertification required, but Certification basis is adequate.
Redesign floor structure.	No	No	No	By itself, not a significant product change. It is

Description of Change	General configuration changed?	Principles of construction changed?	Certification assumptions invalidated?	Notes
				significant if part of a cargo conversion of a passenger aircraft.
Novel or unusual method of construction of a component.	No	No	No	The component change does not rise to the product level. Special conditions could be required if there are no existing Certification specifications that adequately address these features.
Initial installation of a non-essential APU.	No	No	No	A stand-alone initial APU installation on an aircraft originally designed to use ground- or airport-supplied electricity and air conditioning. In this case, the APU would be an option to be independent of airport power.
Extending limit of validity (LOV)	No	No	No	Extending an LOV without any other change to the aircraft is not a significant change. However, if extending the LOV requires a physical design change to the aircraft, the design change is evaluated to determine the level of significance of the design change.
Changes to the type or number of emergency exits by de-rating doors or deactivating doors with corresponding reduction in passenger capacity.	No	No	No	The new emergency egress does not exceed that previously substantiated because the certified number of passengers is reduced.
Request for ETOPS Type Design Approval for a Type Design change of a product with an existing ETOPS Type Design Approval.	No	No	No	A change to a product with an existing ETOPS Type Design Approval without a change to diversion capability would normally not be significant. However, if the existing ETOPS Type Design Approval was based on policy prior to the adoption of transport category ETOPS Airworthiness standards, then there is not an adequate Certification basis to evaluate the Type Design change for ETOPS. In this case, the change is still not significant, and the appropriate transport category ETOPS Airworthiness standards would apply.
An avionics change from federated electromechanical displays to federated electronic displays.	No	No	No	Changing an electromechanical display to an electronic display is not considered significant.
An avionics change replacing an integrated avionics system with another integrated avionics system.	No	No	No	The assumptions used to certify a highly integrated avionics system will be the same for another highly integrated avionics system.
Rotary-wing				
Substantial				
Change from the number and / or configuration of rotors (eg main and tail rotor system to two main rotors).				Proposed change to design is so extensive that a substantially complete investigation of compliance with the applicable Certification basis is required.
Change from an all-metal rotorcraft to all composite rotorcraft.				
Significant				
Comprehensive flight deck upgrade, such as conversion from entirely federated, independent electromechanical flight instruments to highly integrated and combined electronic display systems with extensive use of software and / or complex electronic hardware.	No	No	Yes	Affects avionics and electrical systems integration and architecture concepts and philosophies. This drives a reassessment of the human-machine interface, flight-crew workload, and re-evaluation of the original design flight deck assumptions.
Certification for flight into known icing conditions.	No	No	Yes	
(Fixed) flying controls from mechanical to flyby-wire.	No	No	Yes	This drives a complete reassessment of the rotorcraft controllability and flight control failure.
Addition of an engine; eg from single to twin or reduction of the number of engines; eg from twin to single.	Yes	Yes	Yes	—
A change of the rotor drive primary gearbox from a splash-type lubrication system to a pressure-lubricated system due to an increase in horsepower of an engine or changing from a piston engine to turbine engine.	No	Yes	Yes	—
A fuselage or tail boom Modification that changes the primary structure, aerodynamics, and operating envelope sufficiently to invalidate	Yes	No	Yes	—

Description of Change	General configuration changed?	Principles of construction changed?	Certification assumptions invalidated?	Notes
the Certification assumptions.				
Application of an approved primary Structure to a different approved model (eg installation on a former model of a main rotor that has been approved on a new model, and that results in increased performance).	No	Yes	Yes	—
Emergency medical service (EMS) configuration with primary structural changes sufficient to invalidate the Certification assumptions.	No	No	Yes	Many EMS configurations will not be classified as significant. Modifications made for EMS are typically internal, and the general external configuration is normally not affected. These changes are not to be automatically classified as significant. Note: Door addition or enlargement involving structural change would be significant.
Skid landing gear to wheel landing gear or wheel landing to skid.	Yes	No	Yes	—
Change of the number of rotor blades.	Yes	No	Yes	—
Change of tail anti-torque device (eg tail rotor, ducted fan, or other technology).	Yes	Yes	No	—
Passenger-configured helicopter to a firefighting-equipment configured helicopter.	Yes	No	Yes	Depends on the firefighting configuration.
Passenger-configured helicopter to an agricultural-configured helicopter.	Yes	No	Yes	Depends on the agricultural configuration.
An initial Category A Certification Approval to an existing configuration.	No	No	Yes	—
IFR upgrades involving installation of upgraded components for new IFR configuration.	No	No	Yes	Changes to architecture concepts, design philosophies, human-machine interface, or flight-crew workload.
Human external cargo (HEC) Certification Approval.	No	No	Yes	Must comply with the latest HEC Certification specifications in order to obtain operational Approval. Assumptions used for Certification are considered invalidated when this leads to a significant re-evaluation, for example, of fatigue, quick release systems, one engine-inoperative (OEI) performance, and OEI procedures.
Reducing the number of pilots for IFR from two to one.	No	No	Yes	—
An avionics upgrade that changes a federated avionics system to a highly integrated avionics system.	No	No	Yes	This change refers to the avionics system that feeds the output to displays and not the displays themselves.
An avionics upgrade that changes the method of input from the flight crew, which was not contemplated during the original Certification.	No	No	Yes	A change that includes touchscreen technology typically does not invalidate the assumptions used for Certification. A change that incorporates voice-activated controls or other novel human-machine interface would likely invalidate the assumptions used for Certification.
Not-Significant				
Emergency floats.	No	No	No	Must comply with the specific applicable Certification specifications for emergency floats. This installation, in itself, does not change the rotorcraft configuration, overall performance, or operational capability. Expanding an operating envelope (such as operating altitude and temperature) and mission profile (such as passenger carrying operations to external load operations, flight over water, or operations in snow conditions) are not by themselves so different that the original Certification assumptions are no longer valid at the type-certified-product level.
Forward looking infrared (FLIR) or surveillance camera installation.	No	No	No	Additional flight or structural evaluation may be necessary, but the change does not alter the basic rotorcraft Certification.
Helicopter terrain awareness warning system (HTAWS) for operational credit.	No	No	No	Certified under rotorcraft HTAWS AMC guidance material and ETSO-C194. Does not alter the basic rotorcraft configuration.
Health usage monitoring system (HUMS) for maintenance credit.	No	No	No	Certified under rotorcraft HUMS GM guidance material. Does not alter the basic rotorcraft configuration.

Description of Change	General configuration changed?	Principles of construction changed?	Certification assumptions invalidated?	Notes
Expanded limitations with minimal or no design changes, following further tests / justifications or different mix of limitations (CG limits, oil temperatures, altitude, minimum / maximum weight, minimum / maximum external temperatures, speed, engine ratings).	No	No	No	Changes to an operating envelope (such as operating altitude and temperature) and mission profile (such as passenger-carrying operations to external-load operations, flight over water, or operations in snow conditions) that are not so different that the original Certification assumptions remain valid.
Change from a single channel FADEC to a dual channel FADEC.				Change does not change the overall product configuration or the original Certification assumptions.
Installation of a new engine type, equivalent to the former one, leaving Aircraft installation and limitations substantially unchanged.	No	No	No	Refer to AMC 27 or AMC 29 for guidance. Does not alter the basic rotorcraft configuration, provided there is no additional capacity embedded in the new design.
Windscreen installation.	No	No	No	Does not change the rotorcraft overall product configuration.
Snow skis, 'Bear Paws.'	No	No	No	Must comply with specific Certification specifications associated with the change. Expanding an operating envelope (such as operating altitude and temperature) and mission profile (such as passenger-carrying operations to external-load operations, flight over water, or operations in snow conditions) are not by themselves so different that the original Certification assumptions are no longer valid at the type-certified-product level.
External cargo hoist.	No	No	No	Must comply with the specific applicable Certification specifications for external loads. This installation, in itself, does not change the rotorcraft configuration, overall performance, or operational capability. Expanding an operating envelope (such as operating altitude and temperature) and mission profile (such as passenger carrying operations to external load operations (excluding HEC), flight over water, or operations in snow conditions) are not by themselves so different that the original Certification assumptions are no longer valid at the type-certified-product level.
IFR upgrades involving installation of upgraded components to replace existing components.	No	No	No	Not a rotorcraft-level change.
An avionics change from federated electromechanical displays to federated electronic displays.	No	No	No	Changing an electromechanical display to an electronic display on a single avionics display is not considered significant.
An avionics change replacing an integrated avionics system with another integrated avionics system.	No	No	No	The assumptions used to certify a highly integrated avionics system will be the same for another highly integrated avionics system.
Flight deck replacement of highly integrated and combined electronic display systems with other highly integrated and combined electronic display systems.	No	No	No	Not significant if the architecture concepts, design philosophies, human-machine interface, flight-crew workload design and flight-deck assumptions are not impacted.
IFR upgrades involving installation of upgraded components for new IFR configuration.	No	No	No	No changes to architecture concepts, design philosophies, human-machine interface, or flight-crew workload.
Flight deck replacement or upgrade of avionics systems in non-Appendix 'B' (IFR) or non-CAT 'A' rotorcraft that can enhance Safety or pilot awareness.	No	No	No	—
Modifications to non-crashworthy fuel systems intended to improve its crashworthiness.	No	No	No	—
Changing the hydraulic system from one similar type of fluid to another, eg a fluid change from a highly flammable mineral oil-based fluid (MIL-H-5606) to a less flammable synthetic hydrocarbon-based fluid (MIL-PRF-87257)	No	No	No	—
An ETSO C-127 dynamic seat installed in a helicopter with an existing Certification basis prior to addition of CS 29.562, Emergency landing dynamic conditions.	No	No	No	
Engines				
Substantial				

Description of Change	General configuration changed?	Principles of construction changed?	Certification assumptions invalidated?	Notes
TURBINE ENGINES				
Traditional turbofan to geared-fan engine.				Proposed change to design is so extensive that a substantially complete investigation of compliance with the applicable Certification basis is required.
Low-bypass ratio engine to high-bypass ratio engine with an increased inlet area.				
Turbojet to turbofan.				
Turboshaft to turbo-propeller.				
Conventional ducted fan to unducted fan.				
Turbine engine for subsonic operation to afterburning engine for supersonic operation.				
Significant				
Turbine Engines				
Increase / decrease in the number of compressor / turbine stages with resultant change to approved operational limitations.	Yes	No	Yes	Change is associated with other changes that would affect the rating of the engine and the engine dynamic behaviour, such as backbone bending, torque spike effects on rotors and casing, surge and stall characteristics, etc.
New design fan blade and fan hub, or a bladed fan disk to a blisk, or a fan diameter change, that could not be retrofitted.	Yes	No	Yes	Change is associated with other changes to the engine thrust / power, ratings, and operating limitations; engine dynamic behaviour in terms of backbone bending, torque spike effects on casing, foreign object ingestion behaviour (birds, hail, rain, ice slab); blade-out test and containment; induction system icing capabilities; and burst model protection for the Aircraft. If there is a diameter change, installation will be also affected.
Hydromechanical control to FADEC / electronic engine control (EEC) without hydromechanical backup.	Yes	No	No	Change to engine control configuration. Not interchangeable. Likely fundamental change to engine operation.
A change to the containment case from hard-wall to composite construction or vice versa that could not be retrofitted without additional Major changes to the engine or restricting the initial limitations or restrictions in the initial installation manual.	No	Yes	Yes	Change to methods of construction that have affected inherent strength, backbone bending, blade-to-case clearance retention, containment wave effect on installation, effect on burst model, torque spike effects.
A change to the gas generator (core, turbine / compressor / combustor) in conjunction with changes to approved operating limitations.	No	No	Yes	Change is associated with other changes that would affect engine thrust / power and operating limitations, and have affected the dynamic behaviour of the engine, foreign object ingestion behaviour (birds, hailstorm, rain, ice shed), induction system icing capabilities. Assumptions used for Certification may no longer be valid.
A change from traditional metal to composite materials on an assembly or Structure that provides a load path for the engine affecting the engine dynamic behaviour and / or the engine inherent strength.	No	Yes	Yes	Change to principles of construction and design.
PISTON ENGINES				
Convert from mechanical to electronic control system.	Yes	Yes	No	Change to engine configuration: installation interface of engine changed. Changes to principles of construction: digital controllers and sensors require new construction techniques and environmental testing.
Add turbocharger that increases performance and changes to overall product.	Yes	No	Yes	Change to general configuration: installation interface of engine changed (exhaust system). Certification assumptions invalidated: change to operating envelope and performance.
Convert from air-cooled cylinders to liquid-cooled cylinders.	Yes	No	Yes	Change to general configuration: installation interface of engine changed (cooling lines from radiator, change to cooling baffles). Certification assumptions invalidated: change to operating envelope and engine temperature Certification specifications.
A change from traditional metal to composite materials on an assembly or Structure that provides a load path for the engine affecting the engine dynamic behaviour and / or the engine inherent strength.	No	Yes	Yes	Change to principles of construction and design.
Convert from spark ignition to compression ignition.	Yes	No	Yes	Change to general configuration: installation interface of engine changed (no mixture lever). Certification assumptions invalidated: change to operating envelope and performance.

Description of Change	General configuration changed?	Principles of construction changed?	Certification assumptions invalidated?	Notes
Not-Significant				
Turbine Engines				
Change to the material from one type of metal to another type of metal of a compressor drum.	No	No	No	No change to performance. Assumptions are still valid.
Increase / decrease in the number of compressor / turbine stages without resultant change to operational performance envelope.	No	No	No	No change to performance. Assumptions are still valid.
Hardware design changes to the FADEC / EEC, the introduction of which does not change the function of the system.	No	No	No	No change to configuration. Retrofittable. Assumptions used for Certification are still valid. Possible changes to principles of construction are insignificant.
Software changes.	No	No	No	—
Rub-strip design changes.	No	No	No	Component-level change.
A new combustor that does not change the approved limitations or dynamic behaviour.* (*Exclude life limits.)	No	No	No	Component-level change.
Bearing changes.	No	No	No	Component-level change.
New blade designs with similar material that can be retrofitted.	No	No	No	Component-level change.
Fan blade redesign that can be retrofitted.	No	No	No	Component-level change.
Oil tank redesign.	No	No	No	Component-level change.
Change from one hydromechanical control to another hydromechanical control.	No	No	No	Component-level change.
Change to limits on life limited components supported by data that became available after Certification.	No	No	No	Extending or reducing the life limits. For example, extending life limits based on credits from service experience or new fatigue data.
Changes to limits on exhaust gas temperature.	No	No	No	
Changes to the Airworthiness Limitations section with no configuration changes.	No	No	No	—
Bump ratings within the product's physical capabilities that may be enhanced with gas path changes, such as blade restaggering, cooling hole patterns, blade coating changes, etc.	No	No	No	—
Piston Engines				
New or redesigned cylinder head, valves, or pistons.	No	No	No	—
Changes to crankshaft / crankcase / carburettor.	No	No	No	Component-level change.
Changes to mechanical fuel injection system.	No	No	No	
Changes to mechanical fuel injection pump.	No	No	No	Component-level change.
Engine model change to accommodate new Aircraft installation. No change to principles of operation of major subsystems; no significant expansion in power or operating envelopes or in limitations.	No	No	No	—
A simple mechanical change, or a change that does not affect the basic principles of operation. For example, change from dual magneto to two single magnetos on a model.	No	No	No	—
Subsystem change produces no changes to base engine input parameters, and previous analysis can be reliably extended. For example, a change to turbocharger where induction system inlet conditions remain unchanged, or if changed, the effects can be reliably extrapolated.	No	No	No	—
Change to material of secondary Structure or not highly loaded component. For example, a change from metal to composite material in a non-highly loaded component, such as an oil pan that is not used as a mount pad.	No	No	No	Component-level change.
Change to material that retains the physical properties and mechanics of load transfer. For example, a change to trace elements in a metal casting for ease of pouring or to update to a newer or more readily available alloy with similar mechanical properties.	No	No	No	Component-level change.

Description of Change	General configuration changed?	Principles of construction changed?	Certification assumptions invalidated?	Notes
Propellers				
Substantial				
Change to the number of blades.				Proposed change to design is so extensive that a substantially complete investigation of compliance with the applicable type-Certification basis is required.
Significant				
Principle of pitch change, such as a change from single acting to dual acting.	Yes	Yes	Yes	Requires extensive Modification of the pitch change system with the introduction of backup systems. The inherent control system requires re-evaluation.
Introduction of a different principle of blade retention, such as a single row to a dual row bearing.	Yes	Yes	No	Requires extensive Modification of the propeller hub and blade structure. The inherent strength requires re-evaluation.
A hub configuration change, such as a split hub to a one-piece hub.	Yes	Yes	No	Requires extensive Modification of the propeller hub structure. The inherent strength requires re-evaluation.
Changing the method of mounting the propeller to the engine, such as a spline to a flange mount.	Yes	Yes	No	Requires extensive Modification of the propeller hub structure. The inherent strength requires re-evaluation.
Change to hub material from steel to aluminium.	Yes	Yes	No	Requires extensive Modification of the propeller hub Structure and change to method of blade retention. The inherent strength requires re-evaluation.
Change to blade material from metal to composite.	Yes	Yes	Yes	Requires extensive Modification of the propeller blade Structure and change to method of blade retention. Composite construction methods required. The inherent strength requires re-evaluation.
Change from hydromechanical to electronic control.	Yes	Yes	Yes	Electronic manufacturing and design methods required. Assumptions used for Certification are no longer valid or not addressed in the original Certification, ie HIRF and lightning protection, fault tolerance, software Certification, and other aspects.
Not Significant				
Change to the material of a blade bearing.	No	No	No	Component-level change.
Change to a component in the control system.	No	No	No	Component-level change.
Change to a propeller de-icer boot.	No	No	No	Component-level change.
Changes to the operational design envelope, such as increase in power.	No	No	No	Propeller's operating characteristics and inherent strength require re-evaluation.
Change to the intended usage, such as normal to acrobatic category.	No	No	No	Propeller's operating characteristics and inherent strength require re-evaluation.

Chapter 4: MTC and ADCC Explained

Introduction



1. RA 1015⁵⁸ details the roles and responsibilities of the TAA, RA 5810⁷ provides the regulatory requirements for achieving an MTC and RA 5820⁸⁸ covers changes in Type Design. This Chapter provides additional information to the Regulated Community on the management through the life of an Air System MTC or ADCC, including the reasons for, and implications of, their suspension or revocation, and thus supports the information contained within RA 5810 (and [Chapter 2](#)) and RA 5820 (and [Chapter 3](#)) and replaces information previously contained within MAA/RN/2016/12 and MAA/RN/2016/13. Note that where the guidance for MTC and ADCC is identical, the term ‘Certificate’ will be used to represent both.

2. MAA Regulations, unlike their civil equivalents, are not enshrined in law⁵⁹. Consequently, a Certificate must be held by a Crown Servant over whom the SoS for Defence has authority, rather than by a DO, whose obligations can only be enforced through contractual arrangements. Furthermore, the necessary ability for a MOD DT to be able to change a Type Design without the involvement of the Air System’s Coordinating DO (ie through Service Modifications) is also facilitated by issuing the Certificate to a Crown Servant. Note that the DO still plays a vital role in maintaining the validity of the Certificate and informing the TAA’s decisions, but only through their contractual obligations. Therefore, any enforcement actions taken by the MAA regarding a Certificate apply only to the Crown Servant and not the DO.

MAA Certification

3. MAA issuance of a Certificate, following the successful completion of the MACP by the Air System TAA, provides Assurance to the RTSA and ADH that the TAW arrangements in place for the Type Design, or change to Type Design, have been assessed to be adequate by the MAA as an independent authority. However, as the MACP was introduced in 2011⁴⁰ and was not retrospective, many Air System Types were already in-Service and had not undergone Type Design Assurance by the MAA⁴¹. Consequently, the MAA needs to distinguish between Air Systems that have, and those that have not, received MAA MACP Type Design Assurance; the use of either an MTC or an ADCC achieves this distinction, **Figure 10** refers.

Figure 10 – Comparison of Legacy to non-Legacy Air System Certification

	Into-Service	Major change
 <p>Legacy Air System ie those that are in-Service but have not been awarded an MTC</p>	<p>No MAA Certification (Although may have an MAA Statement of Type Design Assurance)</p>	<p>ADCC issued for first Major change and then up-issued following each Major change</p>
 <p>Air System ie those that have been subject to the MACP prior to In-Service</p>	<p>MTC Issued</p>	<p>MTC up-issued for each Major change</p>

Statement of Type Design Assurance (STDA)

4. Despite the MAA’s Certification regulation not being retrospective, some Legacy Air Systems have undergone a tailored application of the MACP which has resulted in the MAA issuing a STDA. The STDA identifies the extent to which the MAA has been able to assure the Certification evidence provided and will detail any areas where the evidence is unavailable, incomplete, or not understood. Where an STDA has been issued, the level of Assurance will be based on the extent of MAA engagement with the project and degree of compliance with the MACP; definitions of the Assurance levels are as follows:

- a. **Full Assurance.** Effective compliance with the tailored application of MACP has been

⁵⁸ Refer to [RA 1015](#) – Type Airworthiness Management – Roles and Responsibilities. Note that the requirements on a TAA for holding an MTC are identical to those for holding an ADCC.

⁵⁹ EASA’s legal powers derive from its ‘Basic Regulation’ - Regulation (EU) No 2018/1139 of the European Parliament and of the Council of 20 February 2008 and subsequent amendments.

demonstrated with no identified non-compliances and / or MAA LOI with / oversight of design compliance programme is judged to be sufficient to support the degree of Assurance.

b. **Substantial Assurance.** Effective compliance with the tailored application of MACP has been demonstrated, except for a limited number of areas where minor non-compliances have been identified and / or MAA LOI with oversight of design compliance programme is judged to be sufficient to support the degree of Assurance.

c. **Limited Assurance.** Effective compliance with the tailored application of MACP has been demonstrated, except for some areas where significant non-compliances have been identified or where MAA involvement has been limited and / or MAA LOI with oversight of design compliance programme has been limited because of the late stage of engagement.

d. **No Assurance.** Effective compliance with the tailored application of MACP has not been demonstrated. Major areas of non-compliance have been identified in multiple areas of the MACP or MAA involvement in the project has been insufficient to provide Assurance and / or MAA LOI with / oversight of design compliance programme has been insufficient to provide Assurance because of the late stage of engagement.

5. No further STDA will be issued by the MAA; all new Air System Type Designs, and changes to Type Designs, will be issued with either an MTC or ADCC.

Certificates (MTC / ADCC)

6. MAA Certificates verifies that the design has achieved the following:

a. Has been designed by an approved organization¹⁴.

b. Meets the approved TCB, or that:

(1) Any Airworthiness provisions not complied with are compensated for by controls or mitigations that provide an [ELOS](#), or;

(2) The residual RtL resulting from any Airworthiness provisions not complied with are accepted ALARP and Tolerable by the appropriate ADH and that the MAA has deemed that, subject to any caveats (such as a [Restriction](#)), there is no significant reduction in Airworthiness.

7. Not all Major changes to Type Design will be subject to [RTSR Assurance](#) but, where they have been, the Certificate will also show that the Air System is supported by appropriate Aircrew Publications, Technical Information and RTSR containing instructions for its safe operation and sustaining TAW, and a comprehensive TAW Safety Assessment.

8. In contrast to a civil TC, the MAA Certificate will not have an accompanying TCDS because most of the data provided in a civil TCDS is published in the [MCRI A-03](#) and military Air System RTS. The RTS is derived from the TAA's RTSR which are audited by the MAA prior to issue of a Certificate. By auditing the RTSR, the MAA can review the technical data and operating limitations that will be published in the RTS.

Figure 11 – MAA MTC and ADCC Examples

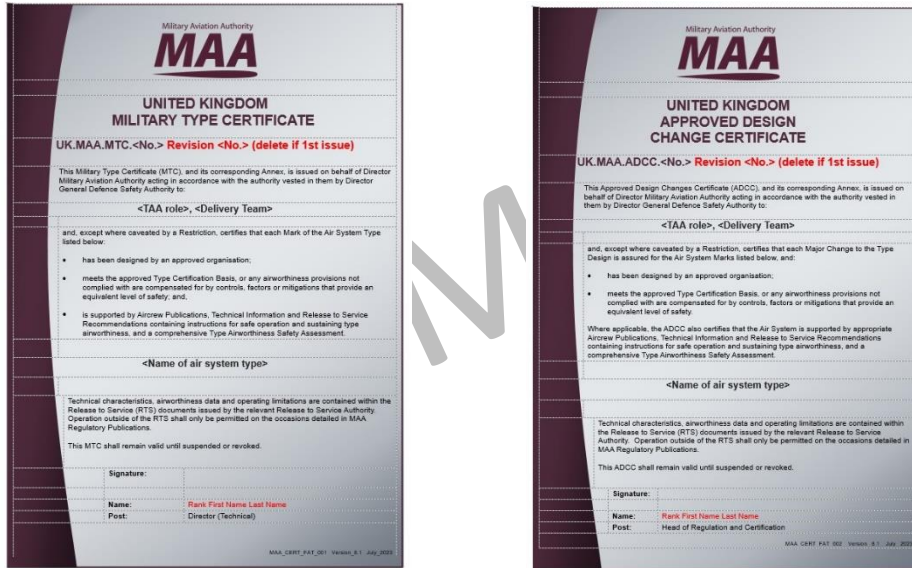

9. Each Certificate will have a supporting Annex that details the certificated Marks / variants of the Type and Major changes in Type Design. For a Restricted Certificate (see below), the Annex will also stipulate a Validity Restriction and / or any MAA-mandated Operating Restrictions.

- a. Each Mark certified will be delineated in the supporting Annex, to identify which changes are relevant to each Mark.
- b. Where one Air System Type has more than one TAA, each TAA will be issued with a Certificate to identify clearly where the Certificate Holder’s responsibility lies for each Mark of the overarching Type.

Civil-derivative Air System MTC

10. Where a military Air System is derived from a civil Type Design⁶⁰, the MTC will reference the civil TC to acknowledge credit awarded for existing Certification Assurance completed by another Regulator. Type Design changes to the civil TC (and potentially also the civil TCDS) will not be duplicated on the MTC.

Figure 12 – Civil TC and TCDS Examples



⁶⁰ For example: Embraer EMB-500 vs Phenom T Mk 1 and Grob 120TP vs Prefect T Mk 1.

ADCC

11. Where ADCCs have already been issued for individual design changes to an Air System Type, these will be incorporated into a single certificate following the next certificated design change. Similarly, where a legacy Air System has been through a tailored MACP that resulted in a STDA, either for the entire Type Design or for a change to the Type Design, then this will also be referenced on the ADCC. Consequently, an ADCC will document the full extent of Assurance provided by the MAA for legacy Air System Types.

Military Certificate Holder (MCH)⁶¹

12. As the Crown Servant responsible for the TAw of an Air System on the MAR, the TAA will become the MCH for that Air System Type. MAA Regulation¹⁹ ensures that the TAA role is always undertaken by a competent individual, thereby allowing a Certificate to be issued to the TAA post rather than to an individual. The MCH is responsible for maintaining the validity of their Certificate and, thus, will fulfil the responsibilities of a TAA⁵, together with the MCH responsibilities.

13. If the MCH wishes to transfer the Certificate to another TAA (other than their successor) within the UK DAE, for example as a result of a re-organization within DE&S, then the prospective new MCH would need to apply to the MAA with sufficient evidence to demonstrate that they are capable of holding the Certificate. This application will be endorsed by the existing MCH and the relevant DE&S Operating Centre Director(s).

14. A Certificate may not be transferred to an export customer even when the Air System has been withdrawn from UK service. This is because the MAA-issued Certificate assumes the Air System is operated on the UK MAR and therefore its validity ceases when the Air System is no longer on the MAR.

Restricted Certificates

15. A Restricted Certificate will be issued where the regulatory requirements have not been fully satisfied but the MAA **▶ has assessed that a level of Safety which is adequate with regard to the intended use has been demonstrated.** ◀ Examples of occasions when a Restricted Certificate might be issued include:

- a. The design or its supporting ADS is incomplete and requires additional validation gained from early in-Service experience and / or ongoing Test and Evaluation.
- b. Shortcomings in Certification evidence were identified during the review of the TCE and RTSR (where carried out) that result in actions being placed on the **▶ Applicant.** ◀
- c. The Air System (new Mark / variant) not being ready to be transitioned to Under Ministry Control⁵⁴ (UMC) at initial RTS. In this circumstance the MAA would expect to understand from the MCH how they would intend to maintain oversight of the Air System configuration such that changes to the configuration, including the need to update the ADS whilst not UMC, would not increase Risk.

16. In cases where additional evidence is required to be presented to the MAA, a validity period will be stipulated on the Restricted Certificate. Failure to satisfy the evidence requirements within this period, or to provide appropriate justification for an extension to the validity period will result in the instigation of Enforcement Action iaw MAA01^{▶1}◀ that may, ultimately, lead to suspension or revocation of the Certificate.

Management of Certificates

Issue of Certificates

17. Certificates will be issued in the following manner:

- a. Certificates will be issued electronically (digitally signed PDF) to the MCH.
- b. The electronic Certificate is the master document, the authenticity of which can be proven using electronic signatures. If a Certificate's authenticity is questioned, a request for authentication can be sent to DSA-MAA-CertPTCGroup@mod.gov.uk with the Certificate

⁶¹ Refer to [RA 5810\(13\)](#): Responsibilities of the Holder (MRP Part 21.A.44).

attached.

- c. All other documents will be raised electronically where possible.
- d. Electronic copies of certificates will be stored in the MAA's Type Certificate Register.

Changes to Certificates

18. Any changes to Certificates will be processed as follows:
 - a. Any future changes in Type Design must be managed by the MCH.
 - b. Regardless of the change, RA 5820 will be followed to ensure that an appropriate Audit trail of Airworthiness evidence is maintained by the MCH to support their Type Design. Where a DO has been granted privileges¹⁴ to classify and approve changes in Type Design, then the MCH will document the extent to which this privilege has been enacted and how oversight is maintained to ensure that the scope of the privilege has not been exceeded.
 - c. If there is a change to the Air System Coordinating DO⁶² listed on the Certificate, then the MCH will need to apply to amend the Certificate. The MCH will need to provide evidence of the competence of the new organization (eg appropriate DAOS Approval) and a declaration that all necessary contractual arrangements are in place for them to adequately support the Type Design.
 - d. It is recognized that there may be occasions where minor administrative changes are required to the Certificate, due to new DE&S position title or DO's name (where there is no underlying change to Airworthiness structure of the organization). In these instances, the MCH can apply for a minor administrative change.
 - e. The MAA will record details of all changes to Certificates in the Type Certificate Register administered by the TC Registrar (email: DSA-MAA-Cert PTC Group@mod.gov.uk).

Enforcement action

19. **MAA oversight of the MCH.** Following military Certification of an Air System, the MAA will maintain oversight of a MCH's Safety processes and their management of Airworthiness issues. This is achieved through Audits and attendance at Airworthiness meetings. Failure of the MCH to adequately manage significant Airworthiness issues will result in the instigation of Enforcement Action iaw MAA01¹. This process commences with the issue of a Corrective Action Requirement and, if the issue continues to remain unresolved, could lead to the suspension or revocation of a Certificate.
20. **Suspension of Certificate.** Suspension of a Certificate, in part or in full, could occur as the result of continued failure of the MCH to meet their Airworthiness responsibilities and where the MAA judge the non-compliance to present a significant Risk to Air Safety iaw MAA01¹. A partial suspension applies to an element of a Certificate and would typically be applied to a specific Mark / variant of the Type but could be applied more specifically to a Major change that has resulted in an unsafe condition. A full suspension applies to all Marks / variants of the Type as detailed on the Certificate.
21. To get a suspension lifted, the MCH will need to demonstrate, through the provision of necessary evidence, that the conditions which led to the suspension have been rectified.
22. **Revocation of Certificate.** Revocation of a Certificate, in part or in full, will occur for one of 2 reasons:
 - a. Following voluntary surrender by the MCH, because either the Air System Type (or Mark / variant) is no longer in service, or the MCH no longer feels that they can meet their responsibilities for managing the Type (or Mark / variant).
 - b. As the result of continued failure of the MCH to meet their Airworthiness responsibilities and where the MAA judge the non-compliance to present a high Risk to Air Safety iaw MAA01¹.

⁶² Refer to [RA 1014](#) – Design Organizations and Co-ordinating Design Organizations – Airworthiness Responsibilities.

23. Like suspension, a Certificate can be revoked in part or in full. A partial revocation applies to an element of a Certificate and would typically be applied to a specific Mark / variant of the Type, although could be applied more specifically to a Major change that has resulted in an unsafe condition. A full revocation applies to all Marks / variants of the Type as detailed on the Certificate. Following revocation, a complete re-Certification of the revoked element of Certificate would need to be completed. When a Certificate has been revoked in full, re-Certification would result in a new Certificate.

Implications of Suspension or Revocation on Military Flying

24. The MCH and applicable ADH and RTSA will be kept informed throughout the stages leading to the suspension or revocation of a Certificate. This correspondence will inform all parties of the non-compliance, its assessed impact on Air Safety and the actions necessary to avoid suspension or revocation. If suspension or revocation action is ultimately taken, the MCH will receive a Notification Letter stating that their Certificate is held in abeyance with immediate effect. In parallel, the ODH and RTSA will be notified so that appropriate actions can be taken.

25. For a civil TC, revocation or suspension will invalidate all Certificates of Airworthiness which, by law, requires all operators to cease flying. However, the implications for revocation or suspension of a MAA Certificate are not derived from law but rather represent removal of MAA Assurance, to the SoS for Defence and ADHs, that the MCH is able to demonstrate continued TAw of the Air System⁶³. Revocation or suspension, therefore, provides a clear statement to the ADH that the MAA can no longer provide Assurance that the Air System Type Design (or Mark / variant for a partial suspension or revocation) is airworthy.

⁶³ Whether as a result of technical issues that cannot be resolved or a failure of their Type Airworthiness management processes.

Chapter 5: Certification Credit within the MACP



Introduction

1. Full application of the [MACP](#) represents a significant undertaking on behalf of both the TAA and the MAA; however, the UK MOD routinely procures Air Systems, or adopts design changes, that are subject to some degree of independent Certification activity. In demonstrating compliance with the [MACP](#), the MAA is therefore prepared to give credit to Certification activities⁶⁴ performed by an ACA but only where these can be demonstrated to be both acceptable to the MAA and applicable to UK MOD configuration and intended usage of the Air System.
2. Claiming Certification credit within the [MACP](#) may avoid unnecessary duplication of effort within both the DE&S DT and the MAA and enables UK MOD resource to be targeted at the areas of greatest Air Safety benefit. However, there are a several aspects for TAAs to consider when deciding whether, or not, requesting credit within the [MACP](#) is an appropriate course of action for a Certification project. The following sections explain some of these considerations; however other aspects, such as the transfer of technical knowledge into the DT for sustaining Type Airworthiness through-life, are also important considerations.

Certification Activities Completed by Another Regulator

3. The [MACP](#) allows the TAA to make a request to claim credit for Certification activities undertaken by another **▶ Accepted Certification Authority, ◀** potentially also using a Certification Specification other than the UK’s benchmark Defence Standard 00-970 (Def Stan 00-970). However, whilst the processes associated with accepting another **▶ Accepted Certification Authority’s ◀** work and those associated with using an Alternative Certification Specification are inexorably linked as shown in **Table 5**, they are often conflated, leading to confusion and resulting in delays to the Certification project; as a result, they will be examined separately within this Chapter. This Chapter also addresses the implications of procuring Air Systems through United States (US) Security Cooperation Programmes. This Chapter supports **▶ the [MAA MMAR](#)⁴ ◀** and replaces MAA/RN/2016/11 and 2019/02.

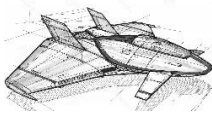
Table 5 – Routes to Certification

	Case 1	Case 2	Case 3	Case 4
Certification Specification	Def Stan 00-970	Alternative Certification Specification	Alternative Certification Specification	Alternative Certification Specification
Regulator	MAA	MAA	Accepted Certification Authority (EASA / FAA / CAA) MAA (for UK Military Deltas)	Accepted Certification Authority (Recognized National MAA) MAA (for UK Military Deltas)
				

4. Requests for credit toward [MACP](#) will usually only be considered when an Air System’s CP will either be completed, or substantially completed, by another Regulator and where that Certification follows a system that has been Recognized⁴ by the MAA. Conversely, where the CP is less mature, the MAA will expect the TAA to influence the conduct and overall outcome of the CP. In addition, where a Regulator has only been a Validating Authority⁶⁵ then a further assessment by the TAA will be necessary to understand the nature of the original CP and the extent of any additional technical conditions or limitations that the Validating Regulator may have imposed as

⁶⁴ In the context of certification, these activities comprise both the manner by which the Regulator’s processes are executed and the resultant production of the final output (ie agreement of a TCB, findings of compliance, issuance of Type Certificate etc).

⁶⁵ An Airworthiness Regulator is a Validating Authority when its Certification relies upon the compliance findings of another Airworthiness Regulator.

part of its validation.

5. Like the UK, many nations have both civil and military Airworthiness authorities to regulate aviation activities within their AoR. ► **National Military Airworthiness Authorities and Regulator equivalents will be collectively termed NMAA.** ◀ Whilst Certification credit within the [MACP](#) can be requested for the activities undertaken by certain civil and military regulators, the MAA treats civil and military regulators differently; as a result, the MAA's Recognition process only applies to other NMAA as explained in the following sections.

Civil Airworthiness Regulators

6. The only civil authorities where the MAA accepts their Certification activity, providing that the Air System's configuration, role and environment ([CRE](#)) is applicable to the MOD product, are the UK CAA, EASA and the FAA – these civil regulators are therefore considered to be ACAs⁶⁶ with no further requirement for additional Assurance activity. This is because civil Regulators have a supra-national governing body (International Civil Aviation Organization (ICAO)) that develops international standards and ► **recommended** ◀ practices which form the reference for states developing their national, legally enforceable, civil aviation requirements; in this way, civil aviation regulators are harmonized all over the world, with any local differences reported back to ICAO and published. Furthermore, many civil regulators cooperate through legally binding Bilateral Aviation Safety Agreements which permits the mutual acceptance of certificates.

7. **Requirements of the TAA.** The requirements of the TAA when certifying an Air System that has previously received Certification by a Civil Airworthiness regulator surround an assessment of the acceptability and applicability of the original Certification activities, taking in to account such factors as intended UK-specific [CRE](#). Additionally, TAAs requesting credit for civil-derived Air Systems also need to consider the extent to which requirements affecting Air Safety are contained in, and inherently levied by, the associated civil operating rules⁶⁷.

► Military Certification Authorities

8. **Military Airworthiness and its Regulation is a sovereign responsibility, which is an important consideration when procuring Air Systems which have been certified by another NMAA, particularly if there is a desire to claim credit for their Certification activities.** Each NMAA has a different starting point influenced by its sovereign national position and legal framework, in addition to military Airworthiness approaches and Risk appetite. Military Airworthiness, regulatory and Assurance activities in different nations may therefore be executed to different standards and using different processes. Furthermore, these Systems and processes are subject to periodic update and changes, as are those of the MAA. Taking the work of another NMAA at face value Risks the acceptance of a product that either differs from the standards that are required under the MRP or that may not be appropriate for the intended UK military use.

9. **Recognition.** Within the UK Defence Air Environment, the only way to make an informed and auditable judgement on the extent to which another nation's military Airworthiness system, comprising of technical Airworthiness activities and products, would be acceptable for use within the MACP is to look and compare. This process, known as Recognition, ensures there is a structured evidence base to support this judgement, while identifying areas of difference and residual Risk. The MAA Recognition process does not assess the validity or appropriateness of any Certification Specification used in the Certification process for a specific Air System by a NMAA, nor is it a validation of the appropriateness of an NMAA's outputs. The Recognition Report describes the NMAA's organization structure and governance, processes for conducting oversight, and the comparability of their processes and procedures governing Certification activities and the issuance of organization Approvals. The Report will aim to identify the NMAA Risk acceptance process and highlight any procedural differences between the NMAA and the MAA. It will also specifically draw the TAA's attention to areas where additional TAA activity will be required in order to provide sufficient Airworthiness Assurance or that TAA's will particularly note in their interactions and deliberations. In future, the Report will be followed by an Implementing Arrangement (IA)

⁶⁶ TAAs wishing to claim credit for Certification activities undertaken by a Civil Airworthiness Regulator other than those listed will need to seek further guidance from MAA, Certification Division.

⁶⁷ Such as equipment essential to safe operation or minimum instrument, data and equipment requirements that are mandated in the civil configuration and therefore assumed.

which is a bespoke document co-owned by the MAA and the other NMAA describing the caveats and conditions under which credit could be claimed for Certification activities or organization Approvals, undertaken by one NMAA can be accepted for use by the other. For further details, refer to the [MAA's MMAR](#). ◀

10. **Process vs Outputs.** Like the MAA, other NMAA apply judgement when assessing evidence within compliance claims against Certification Requirements. However, whilst the Certification processes within each Regulator may be comparable to the MAA's, as confirmed in Recognition, each nation's judgement is coloured by their Risk appetite. Factors such as maintaining a national industrial base, cost, the need to deploy a militarily vital capability (at shorter notice), political pressure and other such factors mean that Certification (or the acceptability of evidence / information) might not be based purely on technical criteria. Moreover, unlike bilateral agreements in civil aviation, Recognition agreements between NMAA are not legally binding, so there is no transfer of legal liability or responsibility when using another military Regulator's output.

11. **Requirements of the TAA.** The requirements of the TAA when certifying an Air System that has previously received either full or partial Certification by a Recognized NMAA⁶⁸ are more complex than when dealing with a civil Airworthiness regulator. Not only does the TAA need to account for UK-specific [CRE](#) of the Air System and national [legislation](#), they also need to assure themselves, and subsequently the MAA, that they have considered the appreciation of national Risk appetite when reusing outputs obtained through Recognition. This will invariably involve the TAA undertaking, and recording for subsequent MAA Assurance, additional Airworthiness Risk-based-Assurance, including deep-dives into high-Risk areas and dip-checks elsewhere. Furthermore, TAAs will need to assess, and mitigate where necessary, the availability of evidence to support additional Assurance activity, especially where such evidence is likely to be subject to commercial intellectual property or security disclosure constraints (such as in [Security Cooperation Programmes](#)).

Prerequisites

12. TAAs intending to request Certification credit towards compliance with the [MACP](#) need to ensure that the following prerequisites have been met and are detailed in their Certification Strategy:

- a. If aiming to use a Civil Regulator, that it is either UK CAA, EASA or the FAA.
- b. If aiming to use a NMAA:
 - (1) A successful Recognition of the NMAA has been completed by the MAA, a Recognition Certificate issued and that this Certificate remains valid; noting that a new ▶project◀ may initiate the need for MAA Recognition of a NMAA for the first time.
 - (2) The DO Approvals and / or Certification processes explained in the NMAA's Military Authorities Recognition Question Set answers during the Recognition process were the same as, or sufficiently similar to, those that the NMAA applied during the Certification of the Air System.
 - (3) The scope of the Recognition (as specified in the MAA Recognition Report and on the Recognition Certificate) includes the acceptance of the NMAA's DO Approvals towards the award of a MAA DAOS Approval and / or the use of the NMAA's Certification artefacts.

13. In addition, a TAA will need to ensure that:

- a. Contractual arrangements are in place to ensure continued unrestricted access to organizational Approvals or artefacts through-life (ie to meet the planned UK out of service date for the Air System).
- b. The Business Need for continued Recognition of an NMAA is re-stated to the MAA during the Recognition Review period (6 months prior to a Recognition lapsing) to ensure

⁶⁸ TAAs wishing to claim credit for Certification activities undertaken by a NMAA, other than those Recognized by the MAA, will need to seek further guidance from MAA, Certification Division.

that the re-validated or renewed Recognition covers the required scope.

14. Where the TAA proposes to establish an enduring relationship with an ACA to certify subsequent Type Design changes to the Air System, then specific arrangements ►will need to◀ be agreed with the MAA.

Type Design Examination (TDE)

15. To be eligible to request Certification credit within the [MACP](#), the TAA will need to successfully complete a structured 2-part TDE which is a comprehensive, fully documented, auditable Review that involves the MAA⁶⁹. This Review is based on the TDE process, as defined in the Canadian Defence Force’s [Technical Airworthiness Manual](#); this process is seen as good practice by the MAA. An overview of this 2-part process is as follows:

- a. **Part A – Assessment of Acceptability and Applicability.** The Part A Review denotes the ‘fork in the road’ for the use of Recognition, ie whether, or not, exploiting MAA Recognition represents a course of action that is both achievable and worthwhile. Accordingly, the Part A Review is a feasibility study and scoping exercise, that includes an assessment of the original Certification activities. This assessment covers both [acceptability](#), taking into account such factors as Certification specifications, Safety etc, and [applicability](#), such as intended UK [CRE](#) and [legislation](#). Where the original Certification activities are agreed by the MAA to be both acceptable and applicable, then a more detailed Part B Review will be undertaken.
- b. **Part B – The Type Design Review.** The breadth and depth of this Part B Review will need to be agreed with the MAA in advance based on the findings of the Part A Review, and may include a technical examination of the original CP. The TAA is responsible for facilitating access to the information, artefacts, facilities and stakeholders necessary to support the Review.

16. **TDE Process – Approach.** Under the previous RN-based approach³, the 2-part review was very transactional in nature and required both the TAA and MAA to produce large, detailed reports in isolation of one another, resulting in the potential for misinterpretation at what is a crucial stage in the Certification ►project.◀ Therefore, a revised approach will be adopted where the TAA and MAA work jointly during the Part A and Part B review periods; this increased LOI by the MAA will make this process both more efficient and effective and ►will reduce◀ the potential for ambiguity and misinterpretation. Therefore, the resultant 2 Review Reports will represent the jointly understood situation at each point in the Review process, ensuring that TAA requests for claiming credit within the MACP are robust and endure through the remaining MACP.

Figure 13 – Part A/B: Previous vs Revised Approach

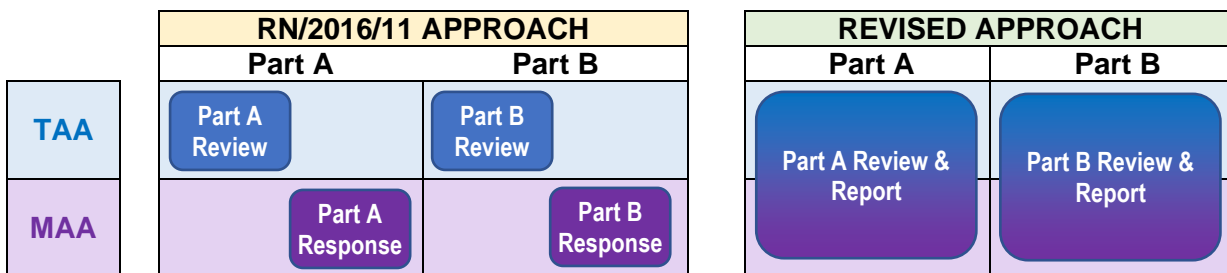

17. **Organizational Approvals.** Where ACAs issue their own organizational Approvals then these may, subject to a number of MAA Recognition pre-requisites⁴, be considered as providing credit towards an application for an MAA-approved organization scheme in support of the MACP. Similarly, TAAs intending to request credit for the ACA’s independent Certification activity as satisfying the MAA’s requirement for Independent Technical Evaluation ►will◀ submit an

⁶⁹ ► Refer to AMC to RA 5810(1): Certification of UK Military Registered Air Systems (MRP Part 21.A.11) and AMC to RA 5820(4): Approval of Major Changes (MRP Part 21.A.97).◀

appropriate application to the MAA.

18. **Timing and completion.** To enable the MAA to provide an assessment of the Certification Risk associated with the ►project◄ as part of the FBC process, the Part A Review needs to be completed, and the findings agreed with the MAA before FBC. Consequently, it is important that the TAA established the necessary contractual cover to undertake the Part A process. Additionally, if the Part A Review identifies significant issues that could only be satisfactorily understood through a more detailed Part B Review, then that specific element will also need to be completed before FBC. If for any reason the Part A Review cannot be successfully completed, then the MAA may decline to give credit to previous Certification activities undertaken by the ACA.

19. **TDE Detailed Guidance: Part A – Assessment of Acceptability and Applicability.**

a. **Assessment of Acceptability.** While the MAA will have acknowledged the policies, processes and capabilities in use by CAA / EASA / FAA, or a NMAA through Recognition, it is incumbent upon the TAA to establish the specific arrangements that applied for each Air System. In particular, the scope of the Air System that was covered is an important factor, as older Air Systems may have been assessed using substantially different criteria from that currently employed by the ACA. Therefore, an assessment of the original design and associated Certification work ►will◄ be performed, as follows:

(1) **Certification Specification.** The Airworthiness standards and Certification requirements identified in the Certification Basis used to certify the original design or design change must be acceptable to the MAA.

(a) For many Certification projects, it is likely that the Air System will have already been designed and developed using a Certification Specification other than the UK's benchmark Def Stan 00-970. The use of [Alternative Certification Specifications](#) is covered later in this Chapter.

(b) For some Certification projects, it is likely that the Certification Specification used for the design and development of the Air System has evolved since the original Certification activity. Consequently, changes to the Certification Specification since original Certification will need to be assessed for their impact on the Airworthiness of the design.

(2) **System Safety.** The system Safety Assessment that was completed during the original Certification activity must be acceptable to the MAA.

(a) Where appropriateness and / or achievement of a level of Safety acceptable to the MAA cannot be demonstrated then an assessment of the implications will need to be submitted for agreement with the MAA.

(b) Where design changes are considered necessary to satisfy any UK-specific Safety standards then the TCB and subsequent Certification arrangements ►will need to be◄ agreed with the MAA in the form of a UK-specific CP Plan.

(c) Alternatively, and with the agreement of the MAA, a more detailed assessment to address any specific questions, problems or issues that arise may be deferred until the Part B Review.

(3) **Scope.** The TAA ►will◄ assess:

(a) The breadth and depth of the original CP undertaken including the processes for finding and documenting compliance. Particular attention ►will◄ be paid to the processes applied to establish and define [SC](#).

(b) The extent to which exemptions, Deviations, [ESF](#) or Risk acceptance against compliance with the TCB have been agreed by the ACA, and the reasons behind them, ►will◄ be examined and understood.

(c) Where the Air System has accumulated a service history then the details of that service history ►will◄ be considered including the management of any unsafe conditions.

(d) The Safety Assessment processes employed ►will◀ be reviewed and a strategy ►will◀ be developed that defines how any existing Safety information can be effectively used to satisfy the UK MOD's requirement for evidence. Any Safety requirement shortfalls ►will◀ be addressed including consideration of omissions or conflicts.

b. **Assessment of Applicability.** The original design and its associated Certification work must be shown to be applicable to the UK Air System for which it is intended. The assessment of applicability ►will◀ address the following areas:

(1) **CRE.** The assessment of applicability must establish the suitability of the design against the intended Air System configuration, operational roles and operating environment in order to assure the assumptions made by the DO and the original Certification authority, as follows:

(a) **Configuration.** The physical configuration of the UK variant of the Air System could be different to that originally certified by the original certifying authority. Capabilities such as night vision equipment, performance-based navigation, Aircrew survival equipment and compatibility with ground support equipment could be different between the UK and original variant of the Air System. Similarly, the UK variant could also be required to carry UK-specific armament and stores. However, ultimately, the design must be suitable for the configuration of the UK Air System for which it is intended. Any significant design or configuration differences between the design that was originally certified and the version of the design for the UK Air System must be addressed during the assessment. The assessment must also identify any proposed additional technical requirements or [SC](#) required to satisfy UK-specific requirements.

(b) **Role.** Even if the Air System configuration is identical, the potential exists that the UK intends to use the Air System in a different manner to that envisaged, and therefore designed and certified, by the original DO and certifying Regulator respectively. Factors to be considered include: flight profiles; usage spectrum; configurations; stores (internal and external); weights; day / night operations; speed and altitude ranges; etc. Examples may include using a civil business jet in a low-level multi-engine training role.

(c) **Environment.** In a similar manner to the Role, the potential exists that the UK intends to use the Air System in different environments to that envisaged, and therefore designed and certified, by the original DO and certifying Regulator respectively. Factors to be considered include: atmospheric; acoustic; vibration; humidity; corrosion and electromagnetic. Examples would be: intending to use an Air System design for desert operations in an Arctic environment; using the Air System on semi-prepared surfaces; and, intending to embark an Air System that wasn't designed to be marinized.

Figure 14 – Configuration and Usage (Role & Environment)

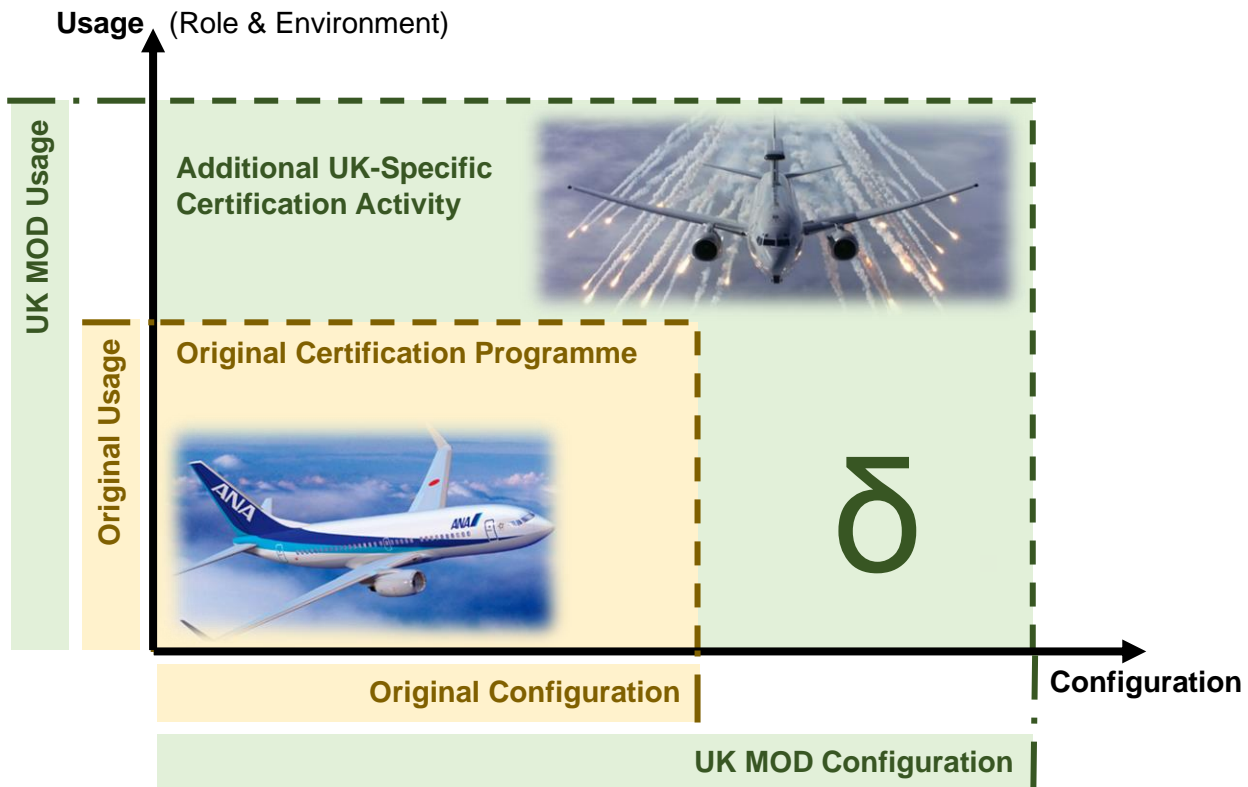

(d) The use of δ in **Figure 14** indicates differences⁷⁰ in either Configuration and / or Usage (Role and Environment) and will be identified before or during the Part A and B Reviews. To aid the TAA in this task, a [CRE Tool](#), used by the Australian Defence Aviation Safety Authority, is seen as good practice by the MAA; an example question set from this tool is shown at **Table 6**. Furthermore, when requesting credit through Recognition of another NMAA, TAAs will need to be cognizant of their [additional requirements](#) in assuring the Airworthiness of the Air System.

(e) **Legislation.** In addition to the CRE aspects listed above, the TAA will also need to satisfactorily address differences in the applicable legislation.

Table 6 – CRE Assessment Tool (Example Considerations)

Operating Factor	Considerations	Possible Implications	Possibly Affect Role	Affected TCB Entries	Assessment Notes	Residual Effect
Performance/Loads						
Landings	- Sharp take-off/landings - Excessive landings (eg touch and go in training environment) - Higher weight landings - Higher sink speeds	May exceed design usage spectrum assumptions				
	Max landing weight	May be affected by specific Defence Modifications				

c. **Part A Review – Key Outputs.** The key outputs of the Part A Review are therefore:

(1) **Initial TCB (iTCB).** The determination of the iTCB is an important output from the Part A Review as it forms a pivotal document for subsequent contract award. Whilst

⁷⁰ For some Air Systems, such as the E-7 Wedgetail ▶ shown in Figure 14, ◀ the change in configuration is obvious; however, the change in usage (role and environment) may be less so and a careful SOI comparison, between the E-7 Wedgetail and its civil Boeing 737 'donor' Aircraft, must be undertaken to ensure that the military usage of the Air System does not invalidate a TAw assumptions.

it is acknowledged that some issues will not be resolved at this stage, the resultant list of MCRIs to address these issues can be agreed with the MAA.

(2) **UK-Specific Certification.** A determination of the requirement for any additional UK-specific Certification activity; such additional Certification activity ►will◄ be conducted in an MAA-agreed CP Plan.

(3) **Part A Findings.** A list of findings that will inform the breadth and depth of the Part B Review of existing compliance evidence; noting that the Part B Review must satisfactorily address all the Part A Findings to enable the TAA to request the appropriate MACP credit.

20. **TDE Detailed Guidance: Part B – Type Design Review.**

a. **Aims.** The aims of the Part B Review are to:

- (1) Satisfactorily resolve all Part A Findings.
- (2) Validate the original assessments made by the ACA.
- (3) Determine the amount of MACP credit that can be awarded by the MAA.

b. **Review Depth.** The Part B Review for each design aspect, system or subject area of the Air System will be based upon the Part A Findings; noting that in order to meet the TAA's wider non-Airworthiness responsibilities a broader, more detailed analysis, may be required. There are 3 levels of Part B Review to consider and the MAA will agree the level required with the TAA as follows:

(1) **Level 1 - Minimal Review.** When the Part A Review has been successfully completed without identifying any significant findings then a Level 1 Review may be appropriate. A Level 1 review would therefore be appropriate when full credit for the original Certification work can be claimed without examining the technical data from the compliance program. This will require that the Certification Requirements and associated standards that form the TCB, the means and methods used to demonstrate compliance, and the processes for making the original findings of compliance are acceptable to the MAA. Consequently, a Level 1 Review would not normally be expected to assess the technical data developed during the CP and may be restricted to an examination and assessment of the associated 'top-level' documentation such as the Type Certificate and accompanying Data Sheet, Master Compliance Record Document or Approved Flight Manual.

(2) **Level 2 - Limited Review.** When the Part A Review identifies that there are findings that need to be resolved, then a deeper Level 2 Review will be required. The intent of a Level 2 Review is to examine the technical data developed during the CP in a limited number of specific areas in sufficient detail to be able to fully address the Part A Findings. The MAA may also require specific aspects of the original work to be reviewed.

(3) **Level 3 - Comprehensive Review.** When the Part A Findings are more significant, broader in scope or anticipated to require greater effort to resolve than a Level 2 Review, then a more detailed Level 3 Review will be required. Note that the scope of the Level 3 Review may be so significant as to replicate, or even exceed, the original ACA's Certification activity. A Level 3 Review would be required when:

- (a) **Acceptability and applicability.** It is not possible to establish the acceptability of the original Certification work or the applicability of the original design for incorporation into a UK Air System.
- (b) **Unresolved findings.** Issues arising from the Part A Review could not be satisfactorily resolved during meetings between the TAA and the MAA.
- (c) **CRE.** There are significant physical design or operational usage differences between the design that was originally certified and the final version of the design that will be incorporated into a UK Air System.
- (d) The MAA requires that specific aspects of the original work be subjected to a comprehensive review.

c. **Unresolved Findings.** During the Part B Review it is likely that either new Part B Findings will be identified, or Part A Findings remain unanswered ; both will result in Unresolved Findings generated by the Part B Review. Where these Unresolved Findings affect compliance with the MACP and are unlikely to be fully and satisfactorily resolved before RTS, then the TAA will need to agree a mitigation process with the MAA. This process may propose accepting the issue indefinitely or involve the implementation of a resolution following RTS. In any case, the TAA will be required to demonstrate that the associated Air Safety Risk has been suitably managed, the necessary stakeholders engaged and any residual Risk has been transferred to the appropriate ADH.

d. **Flight Test.** The Part B Review may identify that an element of live or synthetic flight test is necessary to, for example, permit examination of the flight envelope or provide a handling qualities assessment of UK-specific design changes or operation by UK Aircrew. If this is the case, then the TAA will be responsible for making the appropriate arrangements⁷¹.

e. **Part B Review – Key Outputs.** Following conclusion of the 2-part Review a final Report will be produced by the TAA, and agreed by the MAA, detailing the overall conduct and endorsed conclusions of the Review. The MAA will use this Report together with its overall involvement in the assessment to determine the amount of credit that can be claimed by the TAA towards demonstrating compliance with the MACP. Where further Certification activity is considered necessary then this ►will◄ be added to the UK- specific CP Plan.

21. **TDE - Summary.** The ultimate aim of claiming credit within the MACP is for the TAA to determine, and the MAA to agree, what proportion of the CP can be accepted and what remains to be proven, **Figure 15** refers; specifically:

- a. **Accept.** A proportion of the Certification activity can be read-across from the original ACA's activities, this represents the Certification Requirements that the TAA and MAA can accept as having been previously assured and therefore needs no further compliance Assurance within the MACP other than the TAA requirements list above (when dealing with [civil regulators](#) and [Recognized NMAA](#)).
- b. **Prove.** Conversely, there will be a proportion of the Certification activity where the further compliance Assurance will be required during the subsequent MACP as a result of:
 - (1) Air System differences due to UK [CRE](#) and [legislation](#).
 - (2) UK Military Deltas (Mil Δ) from the benchmark Def Stan 00-970.
 - (3) Application of national Risk appetite by the Recognized NMAA.
 - (4) Airworthiness Risk-based-Assurance by the TAA, including deep-dives into high-Risk areas and dip-checks elsewhere.

⁷¹ Where an Air System is operated under Military Permit to Fly (MPTF), refer to [RA 5880 – Military Permit to Fly \(Development\) \(MRP Part 21 Subpart P\)](#) ►◄.

Figure 15 – Establishing the iTCB

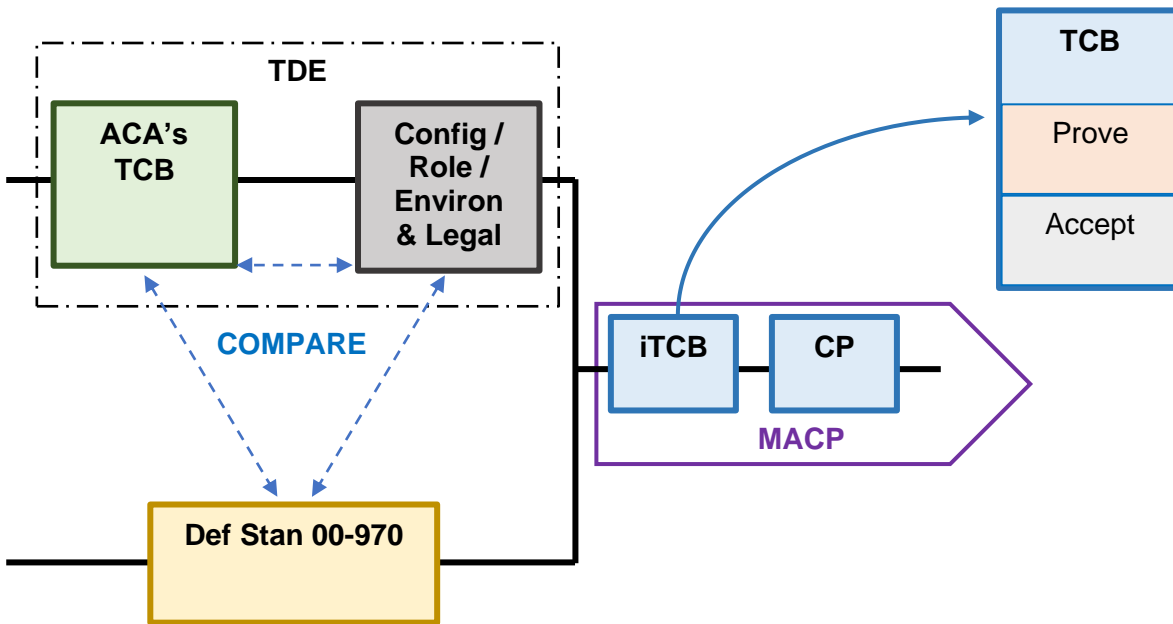

Security Cooperation Programs

22. Many of the MOD's Air Systems are procured from the US, either through a Direct Commercial Sale with a US DO or through a Security Cooperation Programme, such as Foreign Military Sales (FMS). If procured through FMS, TAAs need to be aware of the implications for their Certification ►projects◀ in terms of what Certification artefacts are likely to be available and applicable for Assurance purposes. Using the US Air Force as an example, [Airworthiness Bulletin-345](#) applies to all Airworthiness projects for all FMS cases and directs that:

- a. **Military Flight Release (MFR).** FMS Air Systems will only fly on a United States Air Force (USAF) MFR while on FMS case; thus, the MFR is immediately rescinded at completion of the FMS case and cannot be provided to an FMS customer. However, the list of MFR Restrictions is available.
- b. **Process and Outputs.** The USAF will provide an FMS customer with a full description of USAF Airworthiness processes and products. Furthermore, a Memo of Record on USAF process and Risk findings is also available to an FMS Customer.

23. As a result, it is important for TAAs to discuss their requirements with their FMS point of contact and ensure that configuration and Airworthiness requirements are defined in the contract. It is important that TAAs do not assume that the Air System will automatically satisfy the MACP.

► Enduring Arrangements Post Initial Certification

24. Having incorporated Certification credit into their initial Certification Projects, it is likely that TAAs will wish to continue to apply a similar approach to future Type Design Changes. The TAA will need to agree a suitable approach, documented within their Certification Strategy, with the MAA⁵⁶. The Strategy will need to summarise the results of the TDE and describe how any significant differences in processes or outcomes will be addressed.

25. 'The TAA will need to establish formal arrangements for an enduring relationship with the ACA to ensure that they are aware of any significant changes in organization or processes and can take appropriate action to maintain the validity of their approach. If these arrangements have a dependency on a Recognition undertaken by the MAA International Engagement and Recognition (IE&R) team, the TAA is to maintain frequent engagement with the IE&R team to assure themselves that there has been no change in the scope or any other aspect of the Recognition.'

26. The strategy will need to describe how the TAA proposes to tailor their LOI in the Certification of Type Design Changes and how they will ensure that this is consistent with their responsibilities for the management of Type Airworthiness as detailed in RA 1015⁵⁸.

27. TAAs for Air Systems for which a TDE was not conducted as part of initial Certification, including those based on Types with a current civil Type Certificate would also benefit from articulating their approach to using ACA Certification for credit towards completion of the MACP within a Certification Strategy. MAA Certification Division will work with TAAs to determine the extent to which the requirements of a TDE have been met through initial Certification and agree the arrangements for tailoring the Certification LOI accordingly. ◀

Alternative Certification Specifications

28. The UK MOD maintains its own Design Airworthiness Standards in the form of Def Stan 00-970, which constitutes the UK MOD’s preferred Certification Specification for the design and development of UK military Air Systems. However, it is likely that Air Systems procured from other nations will have already been designed and developed using a different Certification Specification. However, the MAA does not automatically accept other Certification Specifications and their use must therefore be agreed.

29. In considering the use of alternative Certification Specifications, TAAs will define the requirements that would have been applicable using Def Stan 00-970 as the Certification Specification, including establishing the need for SC. This high-level review would include identification of: the Def Stan 00-970 Parts and Amendment States applicable at the date of application to the MAA; the key standards and design philosophies contained therein; and the scope of requirements covered. The intent of this analysis is to provide a UK MOD benchmark against which to compare and assess the original Air System’s TCB and not to establish a fully developed UK TCB⁷², **Figure 16** refers. A TAA will be expected to demonstrate that the original Air System’s TCB is appropriate and that it delivers a level of Safety that is both consistent with the intent of Def Stan 00-970 and is acceptable to the MAA. Where the comparison with the UK Def Stan 00-970 benchmark shows that the requirements are either partially or not comparable, the relevant Def Stan 00-970 requirements will need to be considered for inclusion in the UK TCB. Where it is clear that the design will not comply with the Def Stan 00-970 requirement, and it is not practicable for the design to be changed to enable compliance to be achieved, then the TAA will need to satisfy the MAA that an acceptable level of Safety can be achieved using the original TCB requirements. This overall assessment will need to be informed by a UK Statement of Operating Intent⁷³ and a UK System Requirements Document.

Figure 16 – Air System TCB Benchmarking

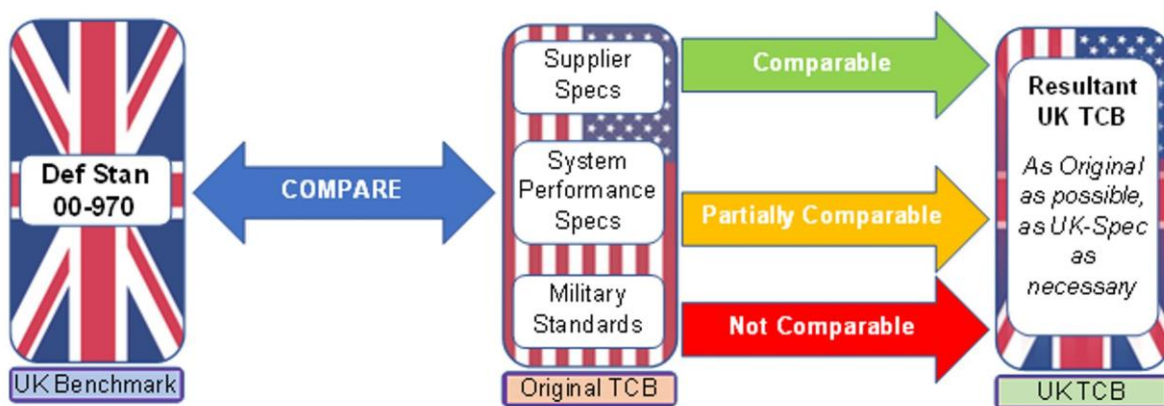

Requirements of the TAA

30. It is important for the TAA to remember that this comparison process, to generate a UK TCB, remains within [MACP Phase 2](#); ie it is not to be confused with the [Equivalent Level of Safety](#) process within [MACP Phase 4](#), which is the process used to assess the adequacy of Safety

⁷² Note that the [EMACC Guidebook and Handbook](#) can provide guidance for the production of a TCB and groups many different civil and military Airworthiness standards by areas of subject interest. Whilst the EMACC does not provide an exhaustive list of Airworthiness standards, nor is it a full guide to demonstrating equivalence, its production was supported by the MAA. ▶▶

⁷³ Or a UK Statement of Operating Intent and Usage for In-Service Air Systems.

arguments against Certification non-compliances. Accordingly, in making the argument for achieving a level of Safety acceptable to the MAA, the TAA will need to demonstrate that the Certification Specification, and other Standards, specified in an original Air System's TCB:

- a. Have been published and maintained by an established authority.
- b. Are accessible, comprehensive and supported by appropriate means of compliance.
- c. Have been used for Air System designs that have achieved an acceptable Safety record.
- d. Can deliver an outcome consistent with the intent of the benchmark requirements derived from Def Stan 00-970.

31. Where the Certification Specification specified in the original Air System's TCB pre-date those in force at the date of application to the MAA, the TAA will assess the key Air Safety benefits introduced by later amendments and explain the implications of not applying them to the MAA⁷⁴. Where an Air System has been designed and developed to a bespoke suite of Airworthiness requirements⁷⁵, rather than a published Certification Specification, then a more detailed assessment will be required in order to understand the selection process, provenance and completeness of the applicable requirements.

Sources of Guidance

32. **EMACC.** The EMACC Handbook contains harmonized Airworthiness Certification criteria which provides 'a framework of Certification criteria to assist in the determination of Airworthiness'⁷⁶. Its purpose is to enable a systematic, disciplined analysis of Certification criteria in order to provide a tailored set of criteria to form the TCB for a specific Air System. The EMACC Handbook references several Airworthiness Specifications as source documents; these are primarily US Joint Service Specification Guides, EASA Certification Specifications and STANAGs. The Handbook also references Def Stan 00-970; however, note that the Handbook has not been updated to reflect the current, transformed version of that Standard due to the UK's departure from the European Union and consequential withdrawal from the European Defence Agency.

33. The Handbook is formatted to provide a read across from the Mil-HDBK-516C and each criterion is described using harmonized text which aims to describe the rationale for each requirement in a non-prescriptive manner. For each criterion, the EMACC Handbook identifies the related requirements from different Airworthiness codes and internationally recognized source documents. However, because the criteria are non-prescriptive, the Handbook does not infer any comparison of Airworthiness outcomes for each of the different Airworthiness Specifications (ie the benchmarking process shown in **Figure 16**) but rather can be used as a guide to assist in identifying additional requirements which will need to be included in the TCB in order to encompass military Certification requirements.

⁷⁴ It is anticipated that this would be a top-level review intended to highlight the most significant developments of the respective standards. For example, earlier versions standards may not have required consideration of high intensity radiated fields or the effects (both direct and indirect) of lightning.

⁷⁵ Such as might be developed to meet a performance-based specification.

⁷⁶ Refer to the EMACC Guidebook – both the EMACC Handbook and Guidebook can be found on the [European Defence Agency Military Airworthiness Authorities Documents website](#).

Chapter 6: Defence Standard 00-970

Introduction

1. As the early pioneers of powered flight discovered, often to their peril, there were numerous fundamental Aircraft design rules that were key to safe flight. These rules, derived from the successes and failures of different design philosophies, were crucial to improving both the Safety, and equally important during the World Wars, the capability of subsequent designs. Whilst this evolving design knowledge was initially captured solely by the Aircraft manufacturers, it was formalized for the first time in 1916 by the Royal Aircraft Factory's 'Design Requirements' 6-page pamphlet. Only two years later, Aircraft design knowledge had developed sufficiently for the Ministry of Munition's Technical Department (Aircraft Production) to issue their 'Handbook of Strength Calculations' (Handbook 806), a set of design standards for military Aircraft that evolved into Aviation Publication 970 (AvP970) and formed the genesis of the 'Design and Airworthiness Requirements for Service Aircraft' (Def Stan 00-970). As **Figure 17** shows, decades of research and development, and the results of numerous Accident investigations, have all contributed to making Def Stan 00-970 a benchmark Standard that spawned Certifications specifications across the world. This Chapter supports the guidance contained within Def Stan 00-970 Part 0.

Figure 17 – Def Stan 00-970 Genesis

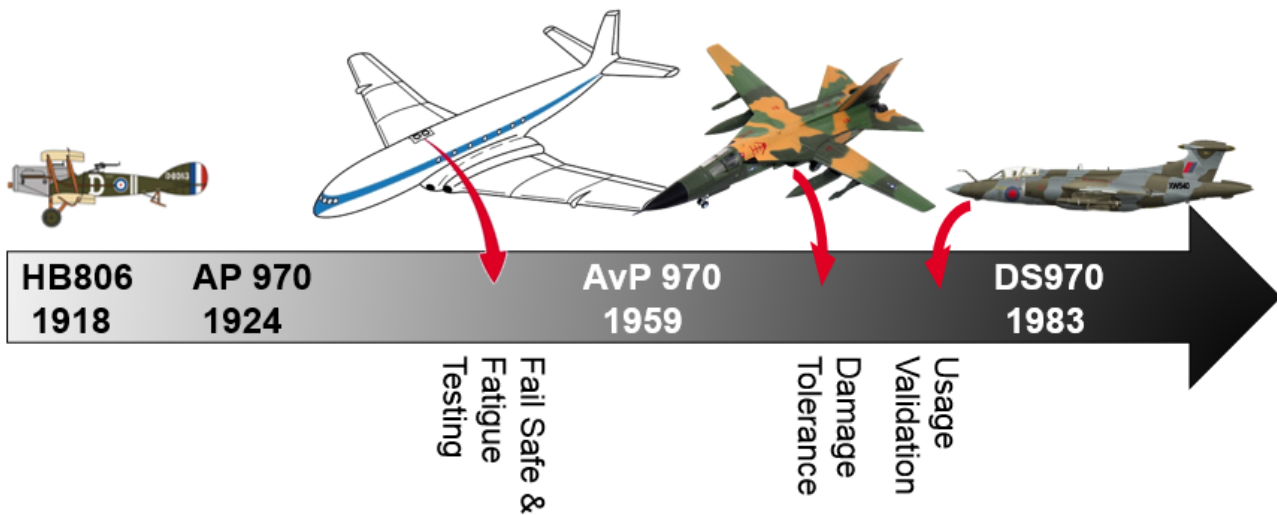

2. Over time, the important Airworthiness and Safety elements of Def Stan 00-970 have become diluted by overly-specific material that did not contribute directly to Airworthiness, such as operational specifications, detailed design guidance, policy and test conduct – much of which had become outdated. Further exacerbating these issues was the way Def Stan 00-970 was subdivided over the years into separate Parts (see **Figure 18**), covering fixed-wing, rotary wing and common equipment. Information had become duplicated, configuration control between Parts was poor and there was an overall lack of coherency across Def Stan 00-970.

Figure 18 – Def Stan 00-970 Evolution (shaded area represents the current situation)

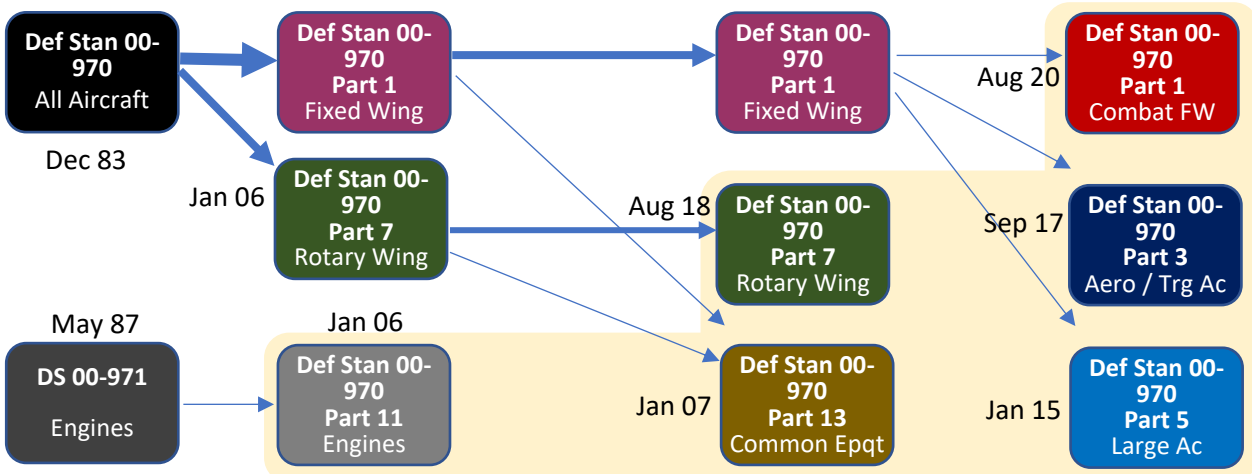

Transformation

Rationale

3. Whilst the development of Def Stan 00-970 stagnated, international Certification specifications continued to be updated to reflect evolving aviation technology and these now represent a more-contemporary standard against which to assess the efficacy of Def Stan 00-970. As a result, a 4 year transformation programme commenced in 2016 to compare Def Stan 00-970 to the EASA's Certification Specifications ([EASA CS](#)). The aim was to produce an updated Def Stan 00-970 which deferred to [EASA CS](#) for most Airworthiness requirements but included military-specific Certification specifications where necessary. This programme culminated in Aug 20 with the publication of the single largest update to Defence Standard 00-970 since its inception in 1983, an update that truly exemplifies the MAA's '*as civil as possible, as military as necessary*' approach.

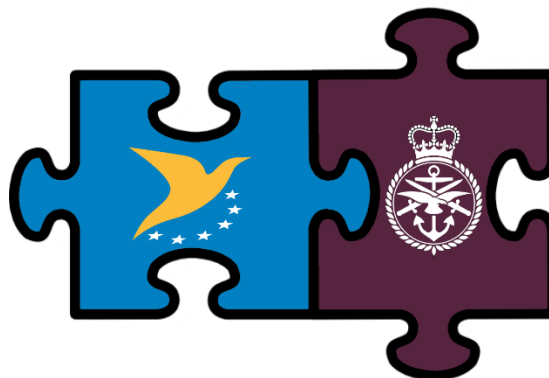

Methodology

4. In order to ensure both a consistent and auditable outcome was achieved across all Def Stan 00-970 Parts, the transformation of Def Stan 00-970 adopted a three-stage approach, as follows (and shown at **Figure 19**):

- a. **Stage 1 – Certification-Related.** With so much material that did not contribute directly to Airworthiness, such as operational specifications, detailed design guidance, policy and test conduct – much of which had become outdated.
- b. **Stage 2 – Comparison with EASA CS.** Those requirements of Def Stan 00-970 identified as Certification-related were reviewed against comparable requirements in the appropriate [EASA CS](#). Any requirements not considered to be adequately addressed by appropriate civil specifications were retained as candidate military deltas.
- c. **Stage 3 – Military Deltas (MilΔ).** Where necessary, the candidate MilΔ were re-written to focus on Airworthiness and Safety outcomes, thereby better matching the [EASA CS](#) approach. Additionally, the MilΔ were then collated into groups that better matched the composition of [EASA CS](#), whilst retaining the three-column format that the Regulated Community preferred; thereby ensuring that the final Def Stan 00-970 remained a user-friendly Certification specification.

5. An important contribution to the success of this project was the application of suitably qualified and experienced resources at each stage, and a high level of stakeholder involvement in the review and endorsement of these requirements. Due to the complexity of the requirements and the need for specific skills and knowledge, the use of DO subject matter expertise was crucial to the development and endorsement of the transformed Def Stan 00-970.

Outcome

6. The removal of non-Airworthiness material from Def Stan 00-970 means that the transformed version is a purer [Certification Specification for Airworthiness](#) than its predecessor. Moreover, the deletion of potentially obsolete operational specifications supports the MOD's intelligent customer role for future Air System design by re-energising the importance of the Capability Sponsor's Air System specification. Similarly, the removal of detailed design guidance empowers DE&S DTs and their DOs by granting far greater latitude to achieve important Airworthiness outcomes. Noting that, whilst the direct linkage between Def Stan 00-970 and [EASA CS](#) simplifies the Certification of civil-derivative Air Systems, the importance of understanding the MilΔ, both in terms of UK configuration and UK usage, is key to ensure a successful [MACP](#) for new Air Systems.

Figure 19 – Defence Standard 00-970 Transformation Methodology

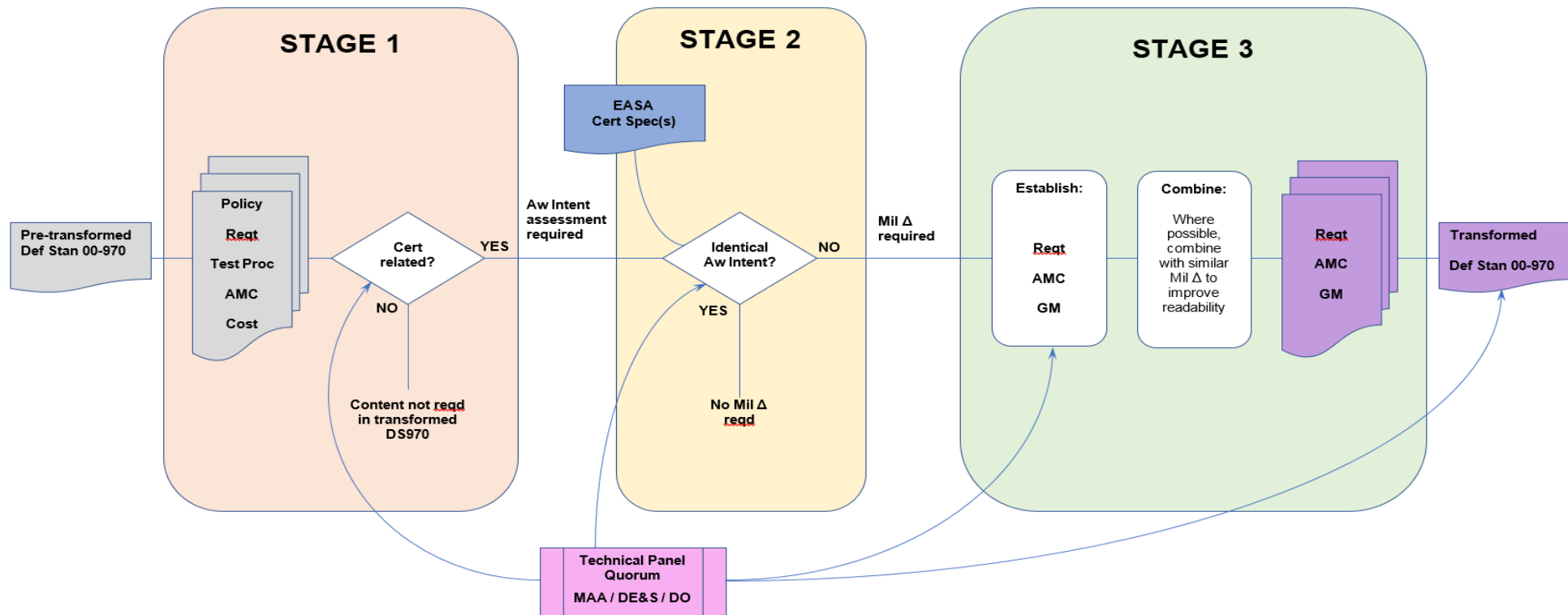

STAGE 1 – Cert / Non-Cert	STAGE 2 – Def Stan 00-970 vs EASA CS	STAGE 3 - MilΔ Production
<ol style="list-style-type: none"> 1. Def Stan 00-970 Part disassembled into individual lines comprising of; Reqt, AMC, Guidance Material (GM), Test Procedure, Policy etc. 2. Each line assessed as to whether, or not, it was Certification related. 3. Assessment confirmed by a Technical Panel Meeting (TPM) comprising of MAA and DE&S SMEs, and a nominated DO (Leonardo Hels for Def Stan 00-970 Part 7 and BAES for Def Stan 00-970 Part 1). 4. Cert-related Reqts, AMC and GM go forward to Stage 2 → 	<ol style="list-style-type: none"> 5. Airworthiness intent of each Def Stan 00-970 Reqt, AMC and GM compared to the corresponding Reqt(s) within EASA CS. <ol style="list-style-type: none"> a. Where the EASA CS met the Airworthiness intent of the Def Stan 00-970 lines, the Def Stan 00-970 line was deleted. b. Where the EASA CS did not meet the Airworthiness intent of the Def Stan 00-970 lines, or no EASA CS equivalent was available, the Def Stan 00-970 line was retained as a Candidate MilΔ. 6. Airworthiness intent assessment confirmed by TPM. 7. Candidate MilΔ (Reqts, AMC and GM) go forward to Stage 3 → 	<ol style="list-style-type: none"> 8. Candidate MilΔs were: <ol style="list-style-type: none"> a. Rewritten into terminology consistent with the EASA CS upon which the Def Stan 00-970 Part was based. b. Collated, where possible, into meaningful Reqt / AMC / GM 'triplets' to match the RC-preferred 3-column Def Stan 00-970 format. 9. DRAFT Def Stan 00-970 line proposals reviewed by TPM. 10. Final 'Camera Ready Copy' and DOORS database produced. 11. Final Transformed Def Stan 00-970 Part reviewed by TPM.

Using Def Stan 00-970

Composition

7. Def Stan 00-970 is hosted on the [Standardization Management Information System \(StanMIS\) website](#) and can also be accessed through the [DStan link](#) within the [Defence Gateway](#). Def Stan 00-970 provides a modular set of requirements that define the fundamental design considerations necessary to produce an Air Systems that is considered airworthy. These are the minimum requirements associated with Airworthiness and do not represent a standard specification. The Standard comprises of 8 Parts, each focused on a different application of UK military-registered Air Systems and based upon a different suite of primary civil and North Atlantic Treaty Organization (NATO) Standards, as described below in **Table 7** and shown at **Figure 20**.

Table 7 – Defence Standard 00-970 Parts

Pt	Applicability
0	Guidance on the use of Defence Standard 00-970: This Part must be read in conjunction with the appropriate Part below and gives essential guidance and overarching policy regarding the use of the Standard.
1	Fixed Wing Combat Air Systems: High-performance, fixed-wing, combat Air Systems. EASA CS-25 requirements are adopted as the basis of Part 1; however, where these requirements are not appropriate for Part 1 Aircraft (eg for high agility design) CS-23 requirements either supplement, or replace, CS-25 requirements. Where neither CS-25 nor CS-23 requirements are insufficient or inappropriate, military-specific requirements either supplement, or replace, CS-25 requirements.
3	Small and Medium Type Air Systems: Fixed-wing Air Systems, fulfilling roles like aircrafts designed to CS-23 (such as primary trainers and light observation / utility) that retain a significant degree of commonality with similar civilian Aircraft. Accordingly, EASA CS-23 requirements are adopted as the basis of Part 3; however, where more-stringent requirements are required (eg Birdstrike) CS-25 requirements either supplement, or replace, CS-23 requirements. Furthermore, where the civil EASA CS are either insufficient or inappropriate, military-specific requirements either supplement, or replace, CS-23 requirements.
5	Large Type Air Systems: Fixed-wing Air Systems fulfilling roles like aircrafts designed to CS-25, albeit with military-specific capabilities such as air-to-air refuelling, ISTAR and tactical transport. Accordingly, EASA CS-25 requirements are adopted as the basis of Part 5; however, where the civil EASA CS are either insufficient or inappropriate, military-specific requirements either supplement, or replace, CS-25 requirements.
7	Rotorcraft: Rotary-wing Air Systems fulfilling roles like rotorcraft designed to CS-29, albeit with military-specific capabilities such as attack, anti-submarine and airborne early warning. Accordingly, EASA CS-29 requirements are adopted as the basis of Part 7; however, where the civil EASA CS are either insufficient or inappropriate, military-specific requirements either supplement, or replace, CS-29 requirements.
9	RPAS: Fixed- and rotary-wing RPAS. NATO STANAG RPAS ⁷⁷ requirements are adopted as the basis of Part 9; however, where these are either insufficient or inappropriate, military-specific requirements either supplement, or replace, the NATO STANAG requirements.
11	Engines: Main and auxiliary engines. EASA CS-E requirements are adopted as the basis of Part 11; however, where the civil EASA CS are either insufficient or inappropriate, military-specific requirements either supplement, or replace, CS-E requirements.
13	Military Common Fit Equipment Military equipment, common to both fixed- and rotary-wing Air Systems, but not referenced in EASA Certification Specifications. Typical examples are air-to-air refuelling and armament equipment / systems. All Part 13 systems will comply with the appropriate Certification requirements of the parent Air System, unless specified differently within Part 13. Accordingly, Part 13 only contains military-specific requirements without reference to any EASA CS.

⁷⁷ Comprising of the following NATO STANAGs: 4671 Unmanned Aerial Vehicles System Airworthiness Requirements (USAR); 4702 Rotary Wing Unmanned Aerial Systems Airworthiness Requirements; 4703 Light Unmanned Aircraft Systems Airworthiness Requirements; 4746 Unmanned Aerial Vehicle System Airworthiness Requirements for Light Vertical Take Off and Landing Aircraft (To be published).

Figure 20 – Structure of Def Stan 00-970

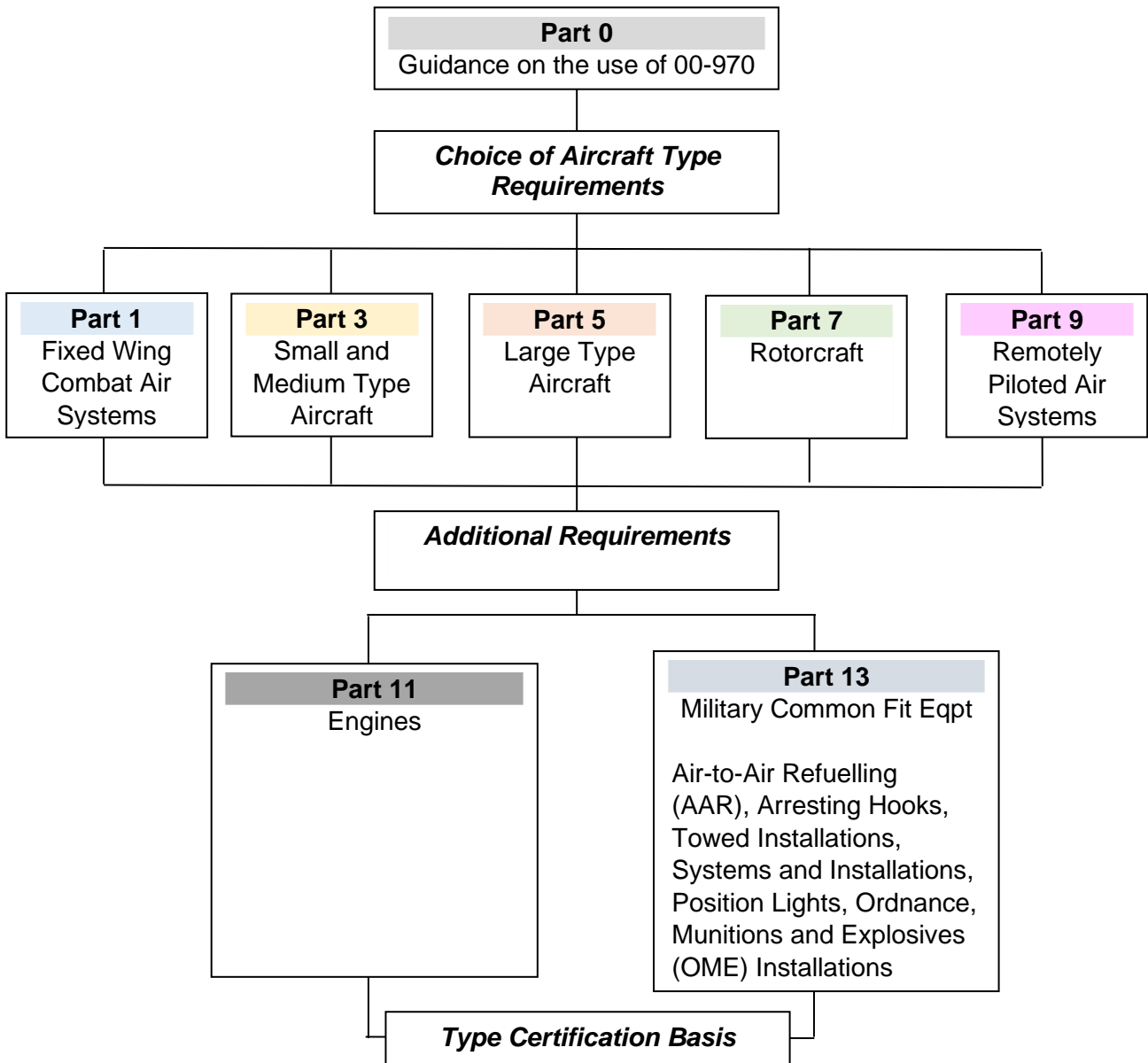

Format

8. Within Def Stan 00-970, there are Parts, Sections, and Clauses. Each Clause of the Standard has been structured into 3 columns to contain information regarding Requirements, AMC and GM, as shown below in **Table 8**.

Table 8 – Defence Standard 00-970 Format

Requirement	Compliance	Guidance
<p>Requirements are the Certification specification that affect Airworthiness and Safety, they will therefore contain the executive verb shall and this is the only place where this particular executive verb will be used. All Requirements will need to be considered in the procurement of UK military Air Systems and subsequent design changes.</p> <p>Note: EASA use the imperative verb must in the Airworthiness Requirements within their Certification Specifications; this will be considered equivalent to the executive verb shall within Def Stan 00-970.</p>	<p>AMC illustrate the preferred means by which Requirements can be met. AMC are written in the permissive sense, using the verb should, in order to allow the Regulated Community to consider alternative approaches to meet the Requirement, in this case Approval from the MAA must be sought.</p> <p>Note: EASA also use the permissive verb should in the AMC within their Certification Specifications; this is to be considered equivalent to the permissive verb should within Def Stan 00-970.</p>	<p>GM contains the technical justification for the requirement and additional information considered useful in achieving compliance with the Requirement. GM may include appropriate references, advice on issues that require consideration or on typical design solutions that have been applied in the past.</p> <p>The use of the verbs must, will, may or could within GM is in line with the definitions provided in MAA02 – MAA Master Glossary.</p>

9. **Sections.** Each Def Stan 00-970 Part is broken down into Sections, as follows:
- a. **Section 1.** This Section is automatically generated by the [StanMIS](#) toolset and contains administrative information, such as: Revision Note; Historical Record; Warning and Standard Clauses.
 - b. **Section 2.** The information provided in Section 2 is provided by the Subject Matter Experts, ie MAA Certification Division, and contains the [Certification Specifications for Airworthiness](#) across several standard sub-sections:
 - (1) **Section 2.1 – General Requirements.** Introduction and Scope of the Standard.
 - (2) **Section 2.2 – EASA CS Related Certification Requirements, AMC and Guidance.** Section 2.2 is the main body of the Standard that contains the cross-references to the EASA CS, plus the additional Military Deltas to those EASA CS.
 - (3) **Section 2.3 – Certification Requirements, AMC and Guidance, Military-Specific Not EASA CS Related.** Section 2.3 contains the Airworthiness Requirements that have no corresponding EASA CS Requirement.
 - (4) **Section 2.4 – General Military AMC and Guidance (Additional to EASA CS AMC).** To ensure that Sections 2.2 and 2.3 remain easy to read, Section 2.4 contains the bulk of the supporting information in terms of AMC and Guidance. Specifically, the majority of the tabular data, graphical information and in-depth guidance is contained in Section 2.4.
 - c. **Section 3.** As with Section 1, this Section is automatically generated by the [StanMIS](#) toolset and contains common information, such as: Normative References; Definitions and Abbreviation.

Interface with EASA CS

10. The operation of Air Systems on the Military Register means that a number of civil EASA requirements are either insufficient, or not appropriate, for military Certification; this has resulted in 'military deltas' being included in Def Stan 00-970 to address any shortfall, or ambiguity, in EASA Requirements or AMC.

11. The key concept of the transformed Def Stan 00-970 is that, unless directed otherwise by Def Stan 00-970, all EASA CS Clauses will need to be considered for applicability for the Type Design and thus for inclusion in the Air System TCB. In addition, all UK Military Deltas are similarly be considered for applicability for the Type Design and thus for inclusion in the Air System TCB.

Thus, whilst the transformed Def Stan 00-970 appears significantly smaller than its predecessor, it is underpinned by the relevant EASA CS, many of which contain hundreds of requirements. An example portion of Def Stan 00-970 is shown at **Table 9** to highlight how Def Stan 00-970 interfaces with EASA CS.

Table 9 – Example Transformed Defence Standard 00-970 – Part 1 (Combat FW)

Requirement	Compliance	Guidance
<p>UK25.33a CS 25.33 shall not apply; it is inappropriate for Part 1 Air Systems.</p> <p><i>[this shows that EASA CS 25.33 (Propeller speed and pitch limits) is inappropriate for jet-powered Combat FW Air Systems and therefore will not be considered for inclusion in the Type Certification Basis]</i></p>	INTENTIONALLY BLANK	INTENTIONALLY BLANK
<p>CS 25.509 Towing Loads</p> <p><i>[this shows that EASA CS 25.509 is appropriate for a Part 1 Air System and will be considered for inclusion in the Type Certification Basis]</i></p>	<p>AMC 25.509</p> <p><i>[this shows that CS 25.509 has corresponding AMC in EASA CS25 Book 2]</i></p>	<p>INTENTIONALLY BLANK</p> <p><i>[this shows that CS 25.509 has no GM; indeed, no EASA CS Part has GM]</i></p>
<p>UK25.509a When any approved towing arrangement does not incorporate appropriate load limiting devices, the Proof and Ultimate factors of 1.5 and 2.0 respectively shall be applied to the loading conditions of CS 25.509 along with consideration for any likely loading conditions not specified in CS 25.509 such as operation at sea.</p> <p><i>[this shows that there is an additional MilΔ Requirement to EASA CS 25.509 that is applicable to Part 1 Air Systems and will be considered for inclusion in the Type Certification Basis]</i></p>	<p>For ship-borne Aircraft a load limiting device is not permitted. The maximum loads should consider the sea states as detailed in the Air System specification. In particular, the case of sudden brake application on a pitching, rolling deck should be considered.</p> <p><i>[this is the AMC to the UK25.509 MilΔ Requirement]</i></p>	<p>Loading conditions not specified in CS 25.509 include those derived from approved towing arrangements when embarked at sea when ship motion may be in combination.</p> <p><i>[this GM to the UK25.509 MilΔ Requirement explains why a MilΔ was required]</i></p>
<p>CS 25.511 Ground load: unsymmetrical loads on multiple-wheel units</p> <p><i>[this shows that EASA CS 25.511 is applicable to Part 1 Air Systems and will be considered for inclusion in the Type Certification Basis]</i></p>	<p>INTENTIONALLY BLANK</p> <p><i>[this shows that CS 25.511 does not have any corresponding AMC in EASA CS25 Book 2]</i></p>	<p>INTENTIONALLY BLANK</p> <p><i>[this shows that CS 25.511 has no GM]</i></p>

12. **Configuration control.** It is important to note that each Def Stan 00-970 Part is baselined against a specific amendment state of an EASA CS; thus, the UK Military Deltas exists because they are not in that EASA CS. Therefore, the correct Def Stan 00-970 Issue needs to be aligned with the correct EASA CS Amendment to ensure that a coherent Certification Specification is used; pairing an earlier EASA CS Amendment with a later Def Stan 00-970 Issue presents a significant Risk that the totality of Certification Requirements will either be incomplete or incoherent, resulting in the Essential Requirements for Airworthiness not being fully assessed.



13.

14.

a.

- (1)
- (2)
- (a)
- (b)
- (c)

- (3)
- (4)
- (5)

b.

- (1)
- (2)
- (3)
- (4)
- (5)

c.

- (1)
- (2)
- (3)
- (4)
- (5)

d.

- (1)
- (2)
- (3)





e.

- (1)
- (2)
- (3)
- (4)

15.

a.

- (1)
- (2)
- (3)
- (4)
- (5)
- (6)
- (7)

- b. 
- c. 
 - (1) 
 - (2) 
 - (3) 

Chapter 7: Novel Technologies

Introduction

1. The rapidly evolving design of Air Systems has led to increasingly complex Certification requirements to ensure Airworthiness through the safe design of Structure, Systems and propulsion which utilize new production methods, materials and design philosophies. However, invariably technological innovations occur for which extant Certification requirements are insufficient to adequately ensure the Airworthiness of the design. As a consequence, Special Conditions (SC) are often devised to bridge this gap in Certification requirements. However, as these novel innovations mature, Certification requirements, that previously existed within the SC, become normalized within the relevant Certification Specifications.

2. Thus, this MMAC Chapter looks at technologies that are currently deemed 'novel' by the MAA and, as a result, require additional Assurance as part of the MACP. As these technologies become normalized, this Chapter will be updated to incorporate the next group of novel technologies; currently this chapter concentrates on the following technologies:

- a. [Additive Manufacturing \(AM\)](#).
- b. [Multi-Core Processors \(MCP\)](#).

Additive Manufacture

3. For the MOD, AM is classed as a novel manufacturing method, despite the process existing within the civil aerospace industry for some time (there are already many certified AM parts in civil aerospace, both polymer and metallic). Consequently, additional process controls need to be established within the Design Organization's **►Quality System◄** to ensure consistency of production. **►It is recommended that this section◄** be read in conjunction with [MASAAG Paper 124](#).

Introduction

4. Traditional manufacturing processes, especially for metallic components, are 'subtractive' in that a component is fabricated (milled, lathed etc) from larger billet of material and then some degree of post-processing (heat treatment, polishing etc) is undertaken on the finished component. Even for polymer components produced using formative manufacturing, there is often a need for post-processing to remove extrusion and injection moulding marks. All this subtractive activity not only results in wasted material but also means that the complexity of the component's internal features is limited to the mould constraints or where a milling tool can access.

Figure 21 – AM Processes: Power Bed Fusion (left) & Material Extrusion (right)

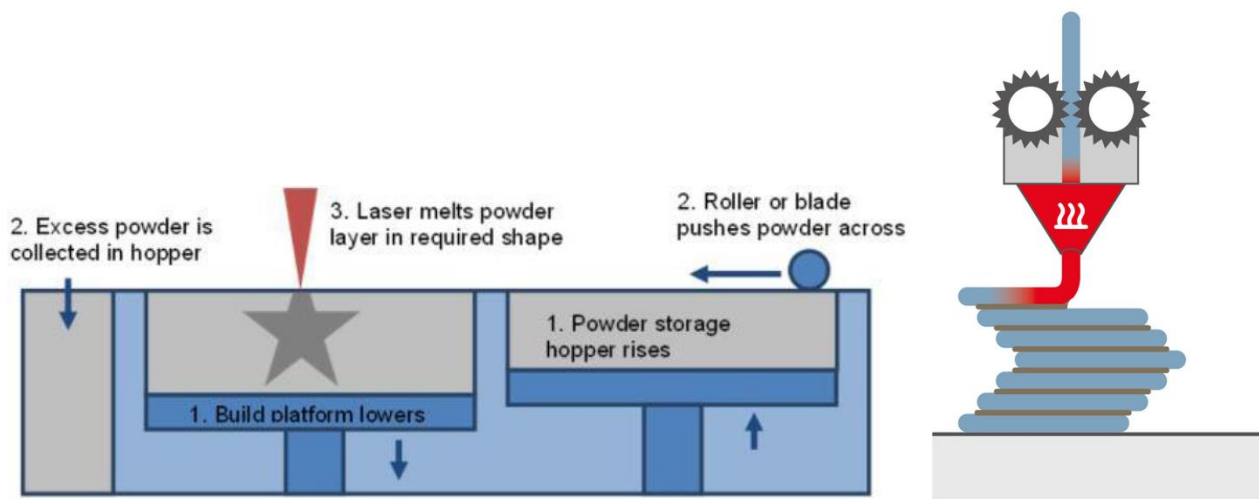

5. **AM.** An Additive process, on the other hand, progressively builds the component 'from the bottom up' through one of several methods. Two of the key techniques, powder bed fusion and material extrusion, are shown at **Figure 21**. In powder bed fusion, laser energy is used to melt the material which is progressively added in layers as a powder; conversely, material extrusion progressively builds the component using molten material injected through nozzle. In comparison to other manufacturing methods, AM offers a number of advantages and disadvantages, as follows:

- a. **Advantages.** AM is a superb method of producing low volumes of highly complex parts; whilst manufacture speed limits its utility for mass production. Significant weight saving can be achieved (through open matrix, highly optimized structures – see **Figure 22 – Component Optimization**) and very little post-production activity is required (unlike metallic castings, for example, which need milling / polishing / heat-treating etc).
- b. **Disadvantages.** However, because the final material and the part itself are produced at the same time, the mechanical properties of AM parts are highly dependent on a complex interaction of factors, including: material feedstock (including batch variability and how the feedstock is stored); manufacturing process (including environmental aspects such as room temperature, humidity, vibration etc); machine configuration and part geometry – as such the potential sources of scatter are both numerous and unfamiliar. As such, particular care must be taken to control and monitor process parameters; note that this is no different to how carbon-fibre composite manufacturing was introduced to aviation three decades ago.

Figure 22 – Component Optimization



Certification Requirements

6. There are no additional or AM-specific Certification Requirements / AMC in Def-Stan 00-970, EASA CS or **▶ FAA Certification Specifications. ◀** Therefore, compliance with existing requirements must be demonstrated, or applicable Special Conditions must be developed if the extant requirements are judged to be inadequate or inappropriate. In civil aviation, the Certification of AM parts has been previously achieved through the demonstration of compliance to existing requirements, making particular use of AMC originally developed for composite materials, which are subject to many of the same Airworthiness considerations.

Component criticality

7. As with structural components manufactured using traditional methods (ie casting, milling etc) the level of Assurance required on the design and production process is dependent upon the criticality of the component's use. For example, metallic AM components designed as Structural Significant Items (ie control surface components) need a significantly greater level of Assurance than a polymer component designed as tertiary structure (ie cockpit secondary instrument mountings etc). As with traditionally manufactured components, this Assurance needs to extend across the full spectrum of manufacture:

- a. **Part design.** The key factors in the design of AM parts, namely; part geometry, attaining the desired physical and mechanical properties of the final printed part and how to deal with anisotropy in a part as a consequence of the additive manufacture process. Anisotropy resulting from the AM characteristics of the specific polymer and the features of

the build design, ►will◀ be accounted for when establishing mechanical and physical properties against the part design requirements. While published property databases will be valuable in guiding material choice, the final AM part properties may be anisotropic and therefore different in different directions.

- b. **Build design.** In AM, as in other manufacturing processes, for example welding, the operator can be a source of variation in the final part. In addition, the choice of AM machine, the conversion of the computer-aided design (CAD) are equally as important decisions regarding the part build orientation, build support structure and choice of test specimens. In particular the effects of part configuration, scan strategy and build parameters on the anisotropy and thermal history of the part could lead to a significant scatter in relevant part properties. Consequently, for critical components these variables will be fixed to those optimised in the design phase of the build and then qualified for the part.
- c. **Post-processing.** There are numerous potential post-processing activities to consider. Each part will ultimately have its own set of post-processing activities to go through: some surfaces may be prepared for bonding, some areas may need precision machining / reaming for a close fit interface to another part or shaft, some threads may need tapping, etc.
- d. **Component validation.** In AM the shape of each layer being built can impact the melting and solidification of that layer and subsequent / previous layers. This means the design geometry of a part or test specimen can affect the thermal history and subsequently the properties of that component. In particular, anisotropy means that test specimens ►will◀ be carefully orientated and located within the build chamber to ensure their properties are representative of the final part.

Certification Courses of Action (COA).

8. Essentially, there are a 2 potential COAs when producing AM parts depending upon whether the production volume (ie mass vs development production) justifies [1] establishing a fully qualified manufacturing process or [2] a process that delivers a part that can be subsequently tested. These COAs are as follows:

- a. **COA1 – Fully Qualified.** The fully qualified process involves the following aspects:
 - (1) **Material Qualification:** Full material qualification for an AM machine and material requires a significant volume of coupon testing (100-300 for each material qualified); this characterises the properties of the material produced and identifies the process parameters that influence final material properties.
 - (2) **Development of material and process specifications:** The results of the material qualification will define the process specification, which stipulates process monitoring and controls required based on the sensitivities of the material to process parameters identified in the initial qualification.
 - (3) **Equivalence testing:** Every machine to be used in production is qualified through equivalence testing programme to ensure that that material produced on a production machine belongs to the same population as the material produced during initial qualification.
 - (4) **Process Control Monitoring:** Strict control and monitoring of process during part production, as per the process specification.
 - (5) **Quality Inspections:** Detailed inspection of all parts, often X-ray inspection of metallic parts to identify any flaws such as porosity, trapped powder or voids. Inspection of AM parts is currently more stringent than for conventionally produced parts machined from billet material, reflecting the novelty of additive manufacturing and the potential for variability in material produced.
 - (6) **Process Control Coupons:** Coupons are manufactured alongside all components and tested to show conformity to the material specification. Coupons are placed at locations throughout the build volume to confirm that material produced throughout is compliant with the material specification for every build.

b. **COA2 – Tested parts.** A developmental approach, often used in limited-production trials activity, involves a demonstration of compliance without additional equivalence testing or qualification testing performed on the AM machine.

(1) Instead, compliance of the production parts will be shown by testing of the parts themselves to ultimate load demonstrating that each individual part produced complies with Airworthiness requirements. Conservatism in the design, in terms of the additional factors of Safety applied, are sufficient to enable each flying part to be tested to ultimate load without damage to the part occurring.

9. **COA Comparison.** Both COAs achieve the desired outcome of an qualified AM-produced component, but each approach is suited to different applications, as follows:

a. **COA1.** COA1 depends on demonstrating that the material and process used will consistently produce material compliant with the relevant Certification requirements. This approach leads to an approved process, material and machine combination that can be used to manufacture a variety of designs, although some part level testing will be required to demonstrate that the geometry of each part does not result in a degradation of material properties.

(1) The advantage of completing COA1 is that a variety of parts can be produced, with reduced levels of testing at the part level, as a foundational understanding and qualification of the non-part specific manufacturing process has been developed. To develop this foundation however, significantly more testing at the coupon level is required.

(2) This additional initial effort and cost make COA1 better suited to a production organisation who are likely to use a specific material, process and machine combination to produce a larger variety or number of parts.

b. **COA2.** COA2 focusses testing the actual flying parts and seeks to demonstrate that each production part is compliant. In this case, any testing and qualification work is applicable only to the specific part for which they are carried out, and not transferable to other parts or designs, as is the case for COA1.

(1) This means the volume of material-level qualification testing is significantly reduced; only traveller coupons are required, making this approach suited to situations where a smaller production run is planned, or where a full qualification is not economical due to time or cost constraints.

(2) A further advantage of COA2 is the possibility to further reduce testing based on a Risk Assessment of part failure. It is possible that a higher level of Risk of failure of the part would be accepted by the authority based on the low consequences to Air Safety.

c. **Common areas.** Common areas of concern are:

(1) **Process Control Document (PCD).** Irrespective of approach, a PCD (or the constitute components list above within each COA) will be a key Certification document that ► will ◀ be provided as part of the AM MCRI during the MACP.

(2) **Intellectual Property Rights (IPR).** Many of the issues surrounding gaining an understanding of the 3D-printer, in order to qualify it, concern gaining an insight into the software that 'drives' the 3D-printer, as opposed to the hardware aspects – this software will invariably be covered by IPR.

Guidance

10. As novel as AM is, there has been significant work undertaken over the last few years in order to better understand the challenges posed by AM.

a. **MAA Military Aircraft Structural Airworthiness Advisory Group (MASAAG).** The MASAAG produced, through Defence Science and Technology

Laboratory (DSTL), ► a [MASAAG Paper 124](#)⁷⁸◄ on the AM of metallic components in late 2018. ►◄ However, noting that polymer AM was likely to be the first airborne application, ► [DSTL were tasked to update the paper to Issue 2 in March 2022.](#) ◄

b. **DE&S Airworthiness Team (DAT).** Concurrently, there has been joint MAA-DAT activity resulting in the production of a paper of the likely COAs for the qualification and Certification of AM components; this Paper ►◄ resulted in the creation of 2 DRAFT MCRIs for the DTs to use when approaching the MAA regarding AM.

c. **EASA-FAA.** Concurrently, EASA have been undertaking [similar activity](#); their conclusions reflect those reached in the above activity. Similarly, the FAA have produced an [AM Roadmap](#) which, whilst ongoing, also currently predicts no changes to extant Certification requirements.

Summary

11. AM offers the opportunity to produce high-complexity components that have previously not been achievable; these complexities generally required multi-part components. In addition, AM offers significant weight savings through highly optimized structures; however, this comes at the cost of needing a thorough understand of the required mechanical properties and durability of the final component, ie how the component reacts to both static and fatigue loading. To gain this understanding, especially in terms of consistency of output, there are 2 manufacturing process approaches that offer significant flexibility depending upon the final employment of the component (ie development vs non-development).

⁷⁸ ► [MASAAG Paper 124 - Guidance on the Qualification and Certification of Additive Manufactured Parts for Military Aviation.](#) ◄

Multi-Core Processor (MCP)

12. For the MOD, MCP are classed as a novel technology and their use, especially within Safety critical systems, must be carefully considered and effective safeguards established to mitigate potential design weaknesses.

Introduction

13. Traditional microprocessors run a single software instruction at a time, fetching the instruction and required data into a single processing unit (core) before executing it and outputting the results. The microprocessor is controlled by a clock, with millions or billions of ticks (clock cycles) per second, but, depending on the instruction, the process of fetching, executing and writing the results may take many clock cycles. MCP seek to improve efficiency by incorporating multiple cores onto a single chip, allowing simultaneous execution of multiple software instructions, and by greater use of very fast memory (cache) within the processor. Thus, MCP offer significant advantages over their single-core counterparts; however, they also pose a number of challenges to Certification:

- a. **Advantages.** Multicore processors typically offer greater processing performance, along with better power and thermal efficiency, compared to the same size of single-core processor. They are more readily available than single core processors, as their advantages have led them to supplant single core processors for most domestic and commercial uses. These same advantages are attractive for use in Aircraft and supporting systems but adoption of MCP for Safety-critical purposes pose some notable additional challenges.
- b. **MCP Challenges.** Despite the obvious appeal, avionics systems that use MCP can experience significantly longer software execution times than with single-core processors due to multicore interference caused by one or more of the MCP cores attempting to access a shared resource (memory, input / output, shared cache etc) that is already in use by another core,
- c. **Figure 23** refers). The resulting delays can impact determinism, performance, and ultimately Safety. Although some mitigation can be achieved at the system level, such as carefully scheduling applications that don't access memory at the same time, those techniques have limited effectiveness and the mitigation can break when any application is modified or replaced. Thus, the very features that make the MCP modules attractive to system designers can cause unintended and unexpected behaviour, and therefore a challenge to certify.

Figure 23 – Multicore Interference

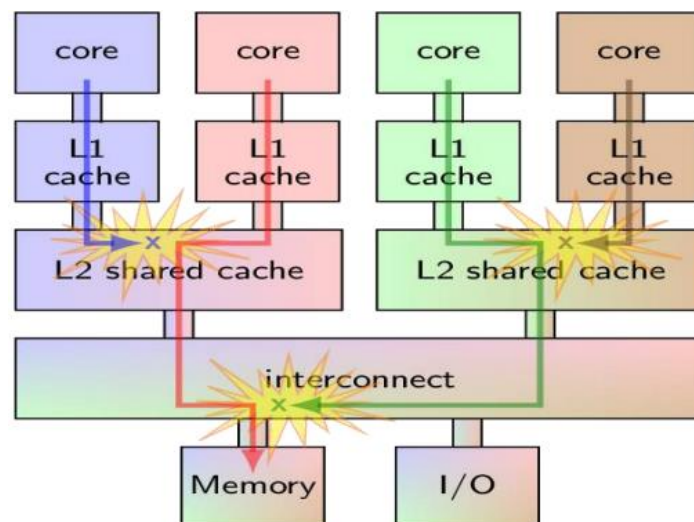

MCP Considerations

14. A prime consideration of Safety functions is typically that the correct action is taken within a set period of time. Software Safety processes go to considerable efforts, proportional to the Safety Risk, in assuring that the code correctly implements the intended functionality and that the worst case execution time (WCET) of such functions is acceptable for the task, **Figure 24** refers. MCP and their supporting software architecture introduce additional complexity to such Assurance that is not captured within current software Safety processes and, as a result, additional Assurance activities are required.

Figure 24 – WCET vs Task⁷⁹

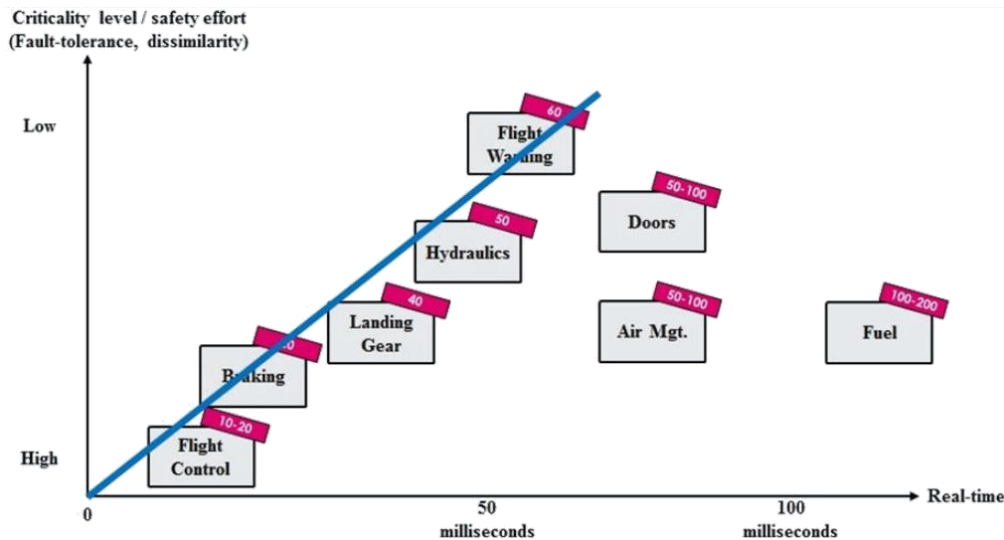

15. It is beyond the scope of the MMAC to provide an exhaustive set of multicore Certification considerations; such considerations have been the subject of many academic and commercial papers, including specific studies for the MOD and for civilian aviation, such as the [EASA MULCORS](#) research project report. A simplistic high-level description of some considerations is provided instead, to give an appreciation of multicore Assurance, but support from an appropriate SME **▶will◀** be sought in planning and developing an Assurance argument.

16. Considerations include:

a. **Access to technical information.** Assurance of MCP is related to a good understanding of the technical design of the processor, but many designs are subject to strict IPR controls of the information. Safety-related uses often represent a very small market for many processors and some manufacturers are reluctant to share deep technical information, even under a non-disclosure agreement, which is a factor for selection of a multicore processor.

b. **Number of Cores and Active / Inactive Cores.** Different MCP have different numbers of cores, eg 2 – 8 or more. Using additional cores may allow more optimal overall use of the processor but may impact on the maximum performance of individual cores and may complicate Assurance of Safety-related functions. Some designs use MCP with more cores than strictly required for the task and deactivate unused cores to limit their potential Safety impact through hardware or software means.

⁷⁹ Source: FAA [DOT/FAA/TC-16/51 'Assurance of Multicore Processors in Airborne Systems'](#), Final Report, July 2017.

Cache usage

17. One of the delays in processing software instructions is the time that it takes to fetch associated information from the computer main memory (RAM), located outside the multicore processor. To speed this up, the processor incorporates small amounts of very fast memory (cache memory), which temporarily mirrors part of main memory and is far quicker to access. Different levels of cache are used, an example of a potential arrangement for a quad-core processor is shown.

18. In the example, small caches are provided that are dedicated to each core (Level 1 / L1 cache), with larger caches shared between pairs of cores (L2) and a larger cache shared by all 4 cores (L3). The caches increase in size, with L1 smallest and L3 largest but L3 still much smaller than the main memory. The speed of access depends on closeness to the core, with L1 fastest and L3 slowest but still much faster than accessing from main memory. The use of caches can offer a significant performance increase but complicates Assurance of Safety-related functions; the same software instruction will take different times to execute if the data is read from L1, L2, L3 or main memory and shared resources represent interference paths between instructions executing on different cores, eg L2 is shared between Core 1 and 2. (As the caches are storing representations of main memory locations, cache coherency mechanisms are used to ensure that cached copies are invalidated if changes are made elsewhere and changes are propagated as required.)

Software Architecture – Symmetric / Asymmetric / Bound multi-processing (SMP / AMP / BMP)

19. In SMP a single operating system controls access to the cores, dividing tasks between the cores. In AMP the cores are separated, potentially running a different operating system on each core under control of an overall hypervisor. On BMP a single operating system controls all cores but cores are dedicated to particular tasks. Each implementation has advantages and disadvantages, typically trading processing power and flexibility with complications on assuring Safety functions.

Partitioning

20. Where a device implements multiple functions, particularly if they are mixed integrity requirements, then time and / or space partitioning may be required as part of the Assurance arguments that the functions will not interfere with each other or with the operating system. The available mechanisms may be dependent on the Operating System being used.

Choice of Operating System

21. A Real Time Operating System (RTOS) is typically required to support Assurance of significant Safety-related functions. Common RTOS used in aviation typically offer a 'certifiable' version, which is provided with a pack of Certification evidence for development Assurance against aviation Certification standards, and aviation RTOS developers are addressing multicore use and Assurance as part of their designs.

Cooling / Thermal Response

22. Modern processors may provide protection against heating effects by throttling their performance (slowing down) if they get hot, potentially compromising their response times for time-critical Safety functions, or reducing their operating voltage, which could potentially make them more susceptible to external interference. The performance of the processor cooling solution, including activation or deactivation of such features, is therefore a factor for assessment of Safety-related functions.

Error Handling / Safety Nets

23. Consideration ►will◄ be given to the safest behaviour if the multicore system encounters errors and for implementing external systems to monitor and react to unexpected behaviour (Safety nets), including implementing graceful degradation of systems where possible.

24. There are many other topics of potential interest, such as lockstep systems (operating the same functions on parallel systems for redundancy), multithreading (executing multiple instructions per core) or speculative execution (pre-fetching and executing future instructions based upon likely results from the current instruction) or multicore systems with different types of core within the same chip, eg Arm Big.LITTLE.

Regulation / Means of Compliance (MC) / Guidance for Assurance of MCP

25. The current MAA MC from Def Stan 00-970 is to provide an MCRI if a Safety-related multicore system is to be used and citing the civilian software position paper, [CAST32A](#), as guidance on considerations and additional objectives for Certification of multicore systems. This MCRI ►will◀ provide the MAA with a description of the proposed multicore implementation and provide an overview on how Safety-related behaviour will be assured on the system to a level commensurate with the Safety Risk.

26. EASA and the FAA will shortly be issuing a harmonised AMC for the Certification of multicore, AMC 20-193 (AC 20-193 for the FAA), as described in EASA [NPA 2020-09](#). AMC 20-193 refines the guidance from CAST32A into an acceptable means of compliance but includes Safety-related systems that are excluded from the AMC (eg iDAL D systems, systems with all but one core deactivated, multithreading, etc.). Once published, the MAA anticipates incorporating this AMC into Def Stan 00-970 but with additional UK Military Deltas to cover excluded systems.

Longevity, Obsolescence and Supportability

27. Whilst not strictly a Certification or multicore-specific issue, consideration ►will◀ be given to the through-life considerations of multicore design decisions. Many MCP, operated at high workloads, may have operational lives far shorter than the associated Air System design. The product life cycles of MCP, driven by commercial pressures, are also relatively short as chips are swiftly replaced by newer, faster models and the older models are not available or supported by the manufacturer. As such, TAAs may face challenges in through-life support for designs and may need to actively plan for providing spares or replacements due to accelerated obsolescence.

Conclusion

28. Ultimately the advantages of MCP, coupled with increased difficulty in sourcing single-core processors, are driving forces for increased adoption of MCP in Safety-related systems and both civilian and military regulators are still developing Regulation / MC / Guidance and working towards best practice for the Assurance of such systems. As such, the use of MCP for Safety-related systems is currently considered a novel technology and the MAA is taking interest in the proposed Assurance and subsequent experiences of implementing and using such systems.