

2024 national curriculum tests

Key stage 2

Mathematics

Paper 3: reasoning

MODIFIED LARGE PRINT

First name _____

Middle name _____

Last name _____

Date of birth Day _____ Month _____ Year _____

School name _____

DfE number _____

Note to markers

This paper should be marked using the standard mark schemes for KS2 Mathematics: Paper 3. There is additional guidance on marking some questions in this paper in the Key stage 2 Mathematics amendments to mark schemes – MLP document.

Instructions

You **must not** use a calculator to answer any questions in this test.

Questions and answers

You have **40** minutes, plus your additional time allowance, to complete this test.

Follow the instructions for each question.

Work as quickly and as carefully as you can.

If you need to do working out, you can use any space on the page.

Method questions

Some questions say: ‘Show your method.’

For these questions, you may get a mark for showing your method.

If you cannot do a question, go on to the next one. You can come back to it later, if you have time.

If you finish before the end, go back and check your work.

1. The shapes on the opposite page have a fraction shaded.

Match each shaded fraction of a circle to the same shaded fraction of a rectangle.

One has been done for you.

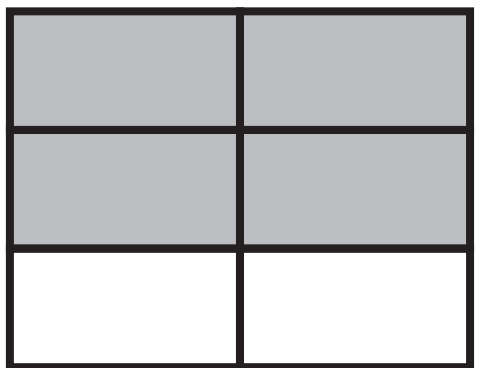
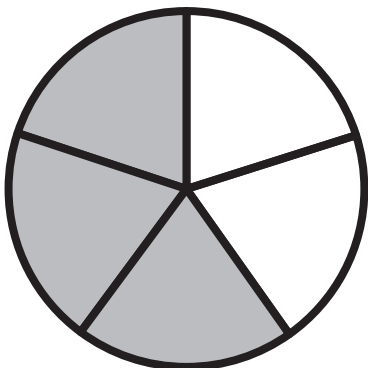
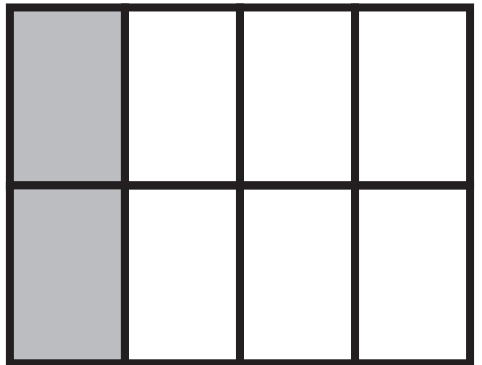
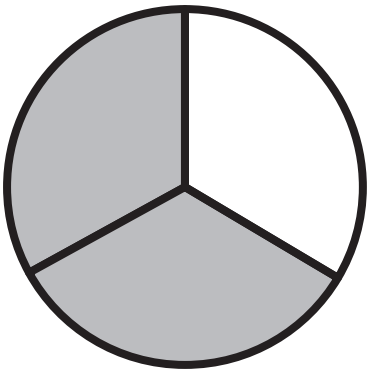
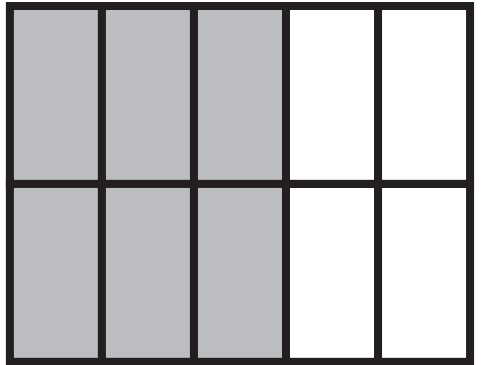
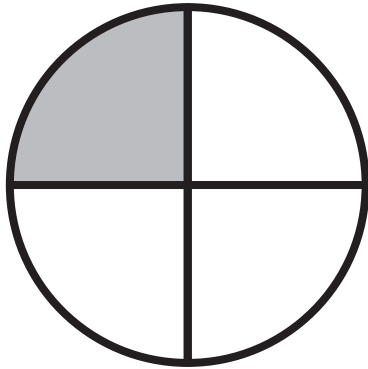
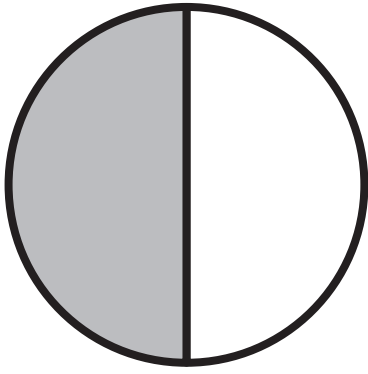

2. The temperature in a freezer is -40°C

The temperature increases by 10°C

What is the new temperature?

_____ $^{\circ}\text{C}$

3. Jack buys milk and orange juice from a shop.

The prices are shown below.

Milk: £1·45

Orange juice: £2·40

He pays with a £5 note.

How much **change does Jack get?**

Show your method.

£ _____

**4. The diameter of the Moon is
3 476 kilometres.**

**What is this diameter to the
nearest hundred kilometres?**

_____ **km**

5. Match each of these Roman numerals to the correct number.

One has been done for you.

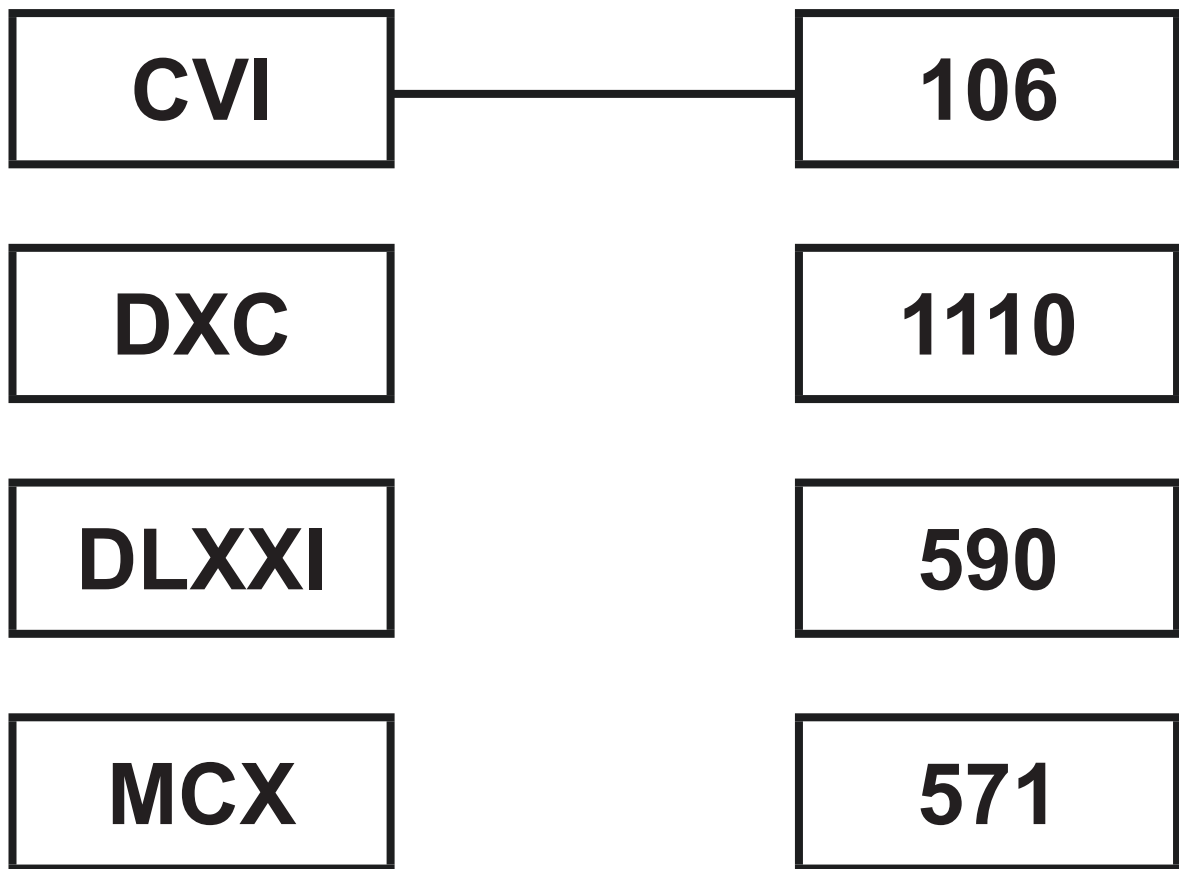

6. Match each fraction to its equivalent simplified fraction.

One has been done for you.

Fraction

**Simplified
fraction**

$$\frac{12}{18} \text{ ————— } \frac{2}{3}$$

$$\frac{12}{20} \qquad \frac{4}{5}$$

$$\frac{12}{15} \qquad \frac{3}{5}$$

$$\frac{12}{16} \qquad \frac{3}{4}$$

**7. Emma thinks of a number.
She multiplies it by 2
adds 11
divides by 3
Her answer is 9**

What number is Emma thinking of?

8. Look at the shape on a grid on the opposite page.

Each square of the grid is 1 unit.

One vertex of the shape is labelled point A.

Mark point A after it has been translated 6 units to the right.

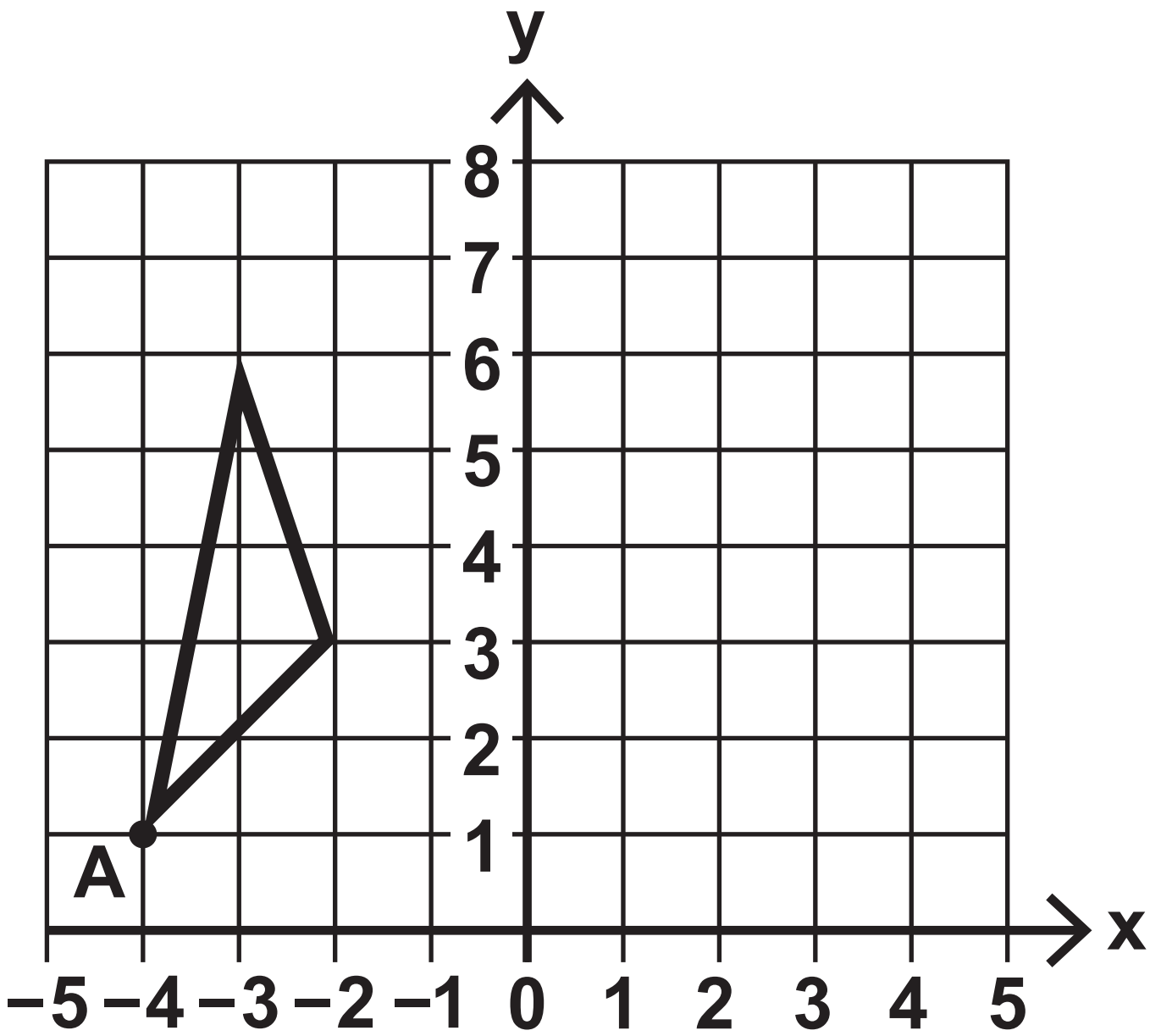

9. Write the missing numbers in the table below.

Number of weeks	Number of days
1	7
2	14
4	28
6	
10	
	105

[BLANK PAGE]

The test continues on the next page

10. Look at the shape below.

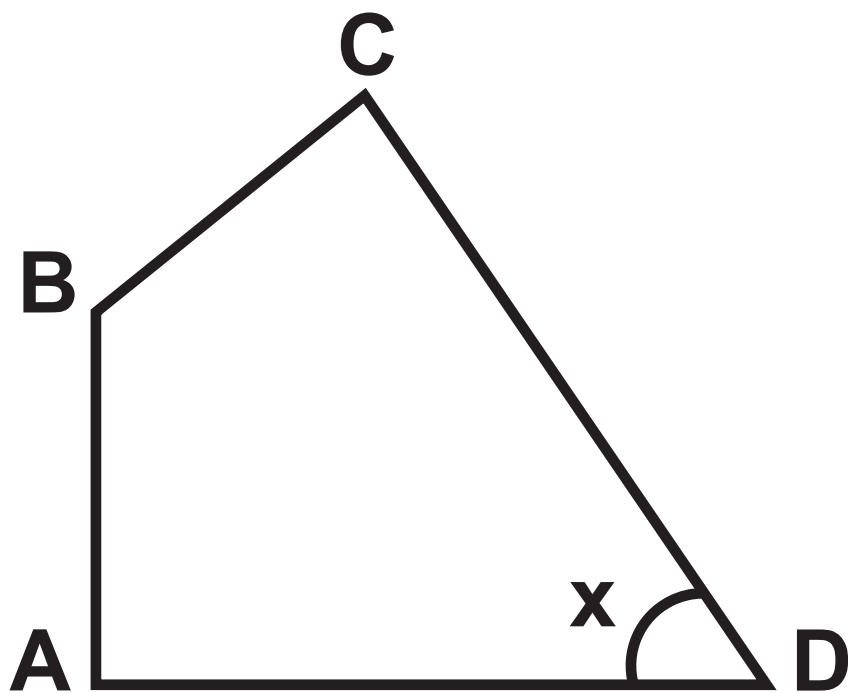

**(a) What is the perimeter of the shape, in millimetres?
Use a ruler.**

_____ **mm**

**(b) Measure the size of angle X.
Use an angle measurer.**

X is _____ **°**

11. Write the missing digits to make the subtraction correct.

$$\begin{array}{r} 57\boxed{} \\ - 3\boxed{}5 \\ \hline \boxed{}68 \end{array}$$

12. Look at the four fractions below.

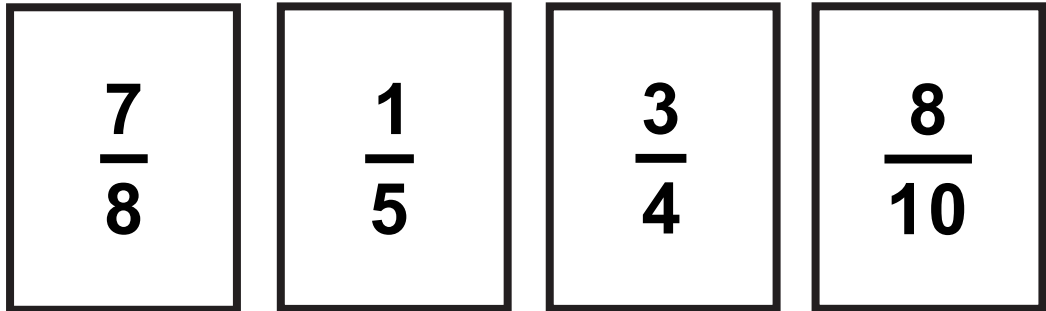

Write the fractions in order starting with the least.

Four empty rectangular boxes are arranged horizontally, intended for the student to write the fractions in order from least to greatest.

least

13. There are 20 boxes on a truck.

The boxes are in 4 different sizes as shown below.

8 of these boxes have a mass of 4 kg

6 of these boxes have a mass of 2.5 kg

4 of these boxes have a mass of 6.5 kg

2 of these boxes have a mass of 13 kg

What is the **total mass** of the
20 boxes on the truck?

Show your method.

_____ kg

14. Look at the data in the table below.

Label	Percentage
A	20%
B	25%
C	15%
D	30%
E	10%

Using this data, draw **two** lines and write **three** labels to complete the pie chart on the opposite page.

Use a ruler.

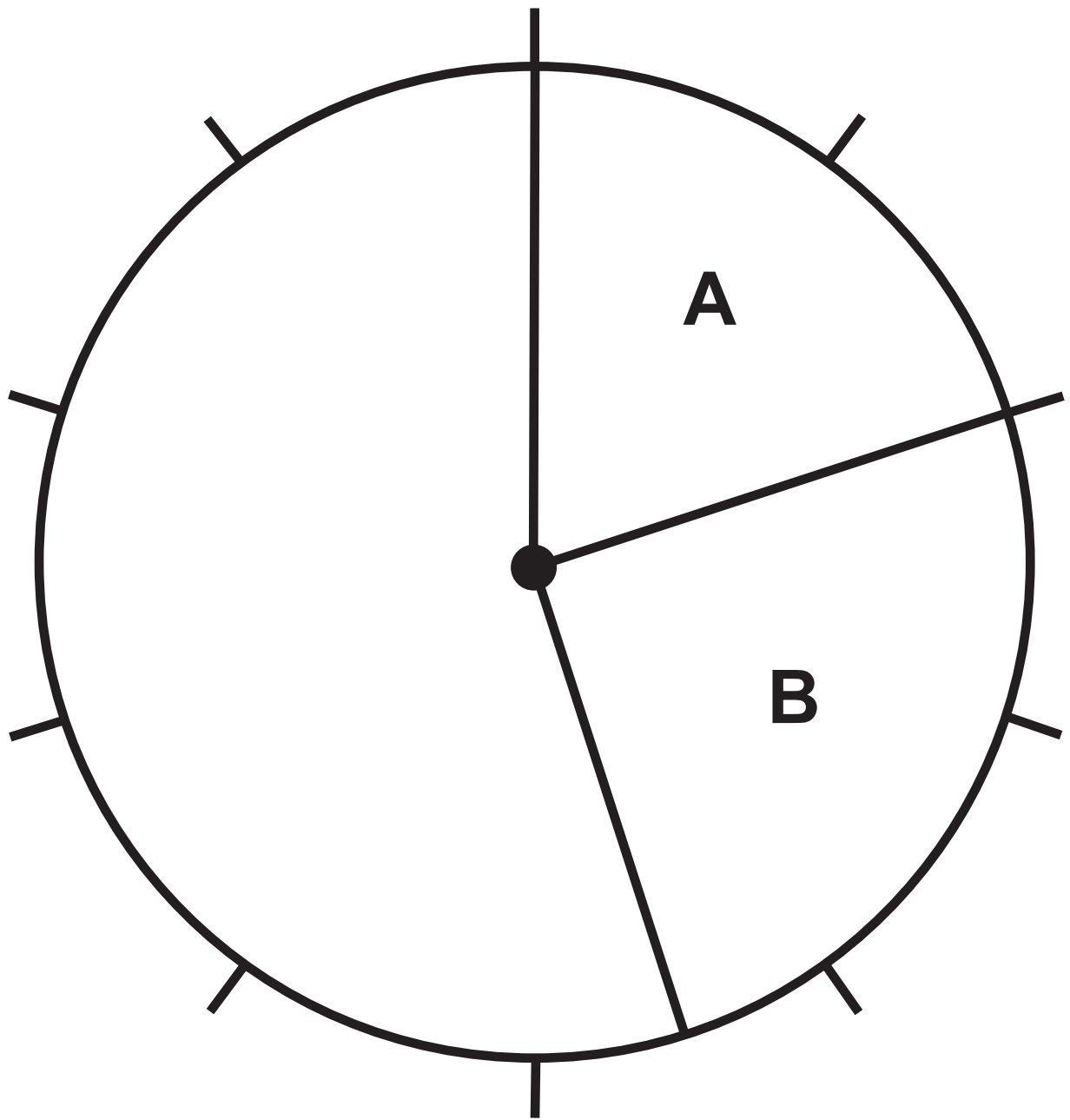

15. 35% of the **680** pupils at a school have a pet dog.

159 of the pupils who have a pet dog are boys.

How many of the pupils who have a pet dog are girls?

Show your method.

16. Write a number in the box to make this correct.

$$\frac{3}{5} < \frac{\boxed{}}{100} < 0.7$$

17. Tick or mark the numbers below that are factors of both 54 and 72

2

3

4

8

9

[BLANK PAGE]

The test continues on the next page

18. Layla wants to buy a camera that costs £65

For the first 10 weeks, she saves £2 each week.

Then she saves £3 each week.

How many weeks **altogether** does it take Layla to save **£65**?

Show your method.

_____ **weeks**

19. Complete this division.

$$\begin{array}{r} \square 64 \text{ r}1 \\ 12 \overline{) 436 \square} \end{array}$$

[BLANK PAGE]

The test continues on the next page

20. Look at the four shapes on the grid on the opposite page.

Write the letters of all the shapes that have only two acute angles.



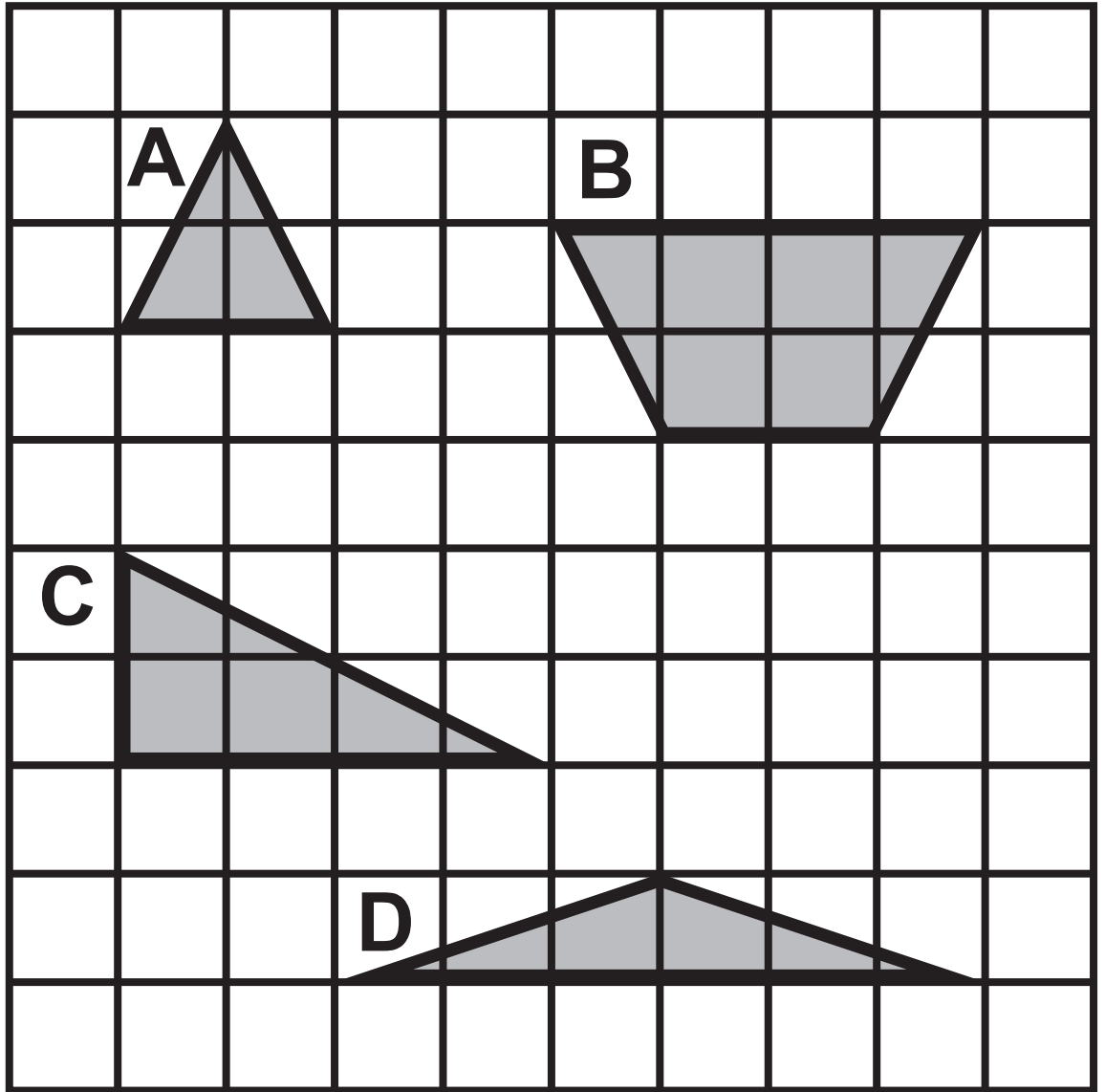

21. A band holds a concert for charity.

The tickets cost £27 each.

They sell 635 tickets.

They pay £3 180 to use the hall.

They give one-third of the remaining amount to charity.

How much money does the band give to charity?

Show your method.

£ _____

22. Sarah makes jewellery using black and white beads.

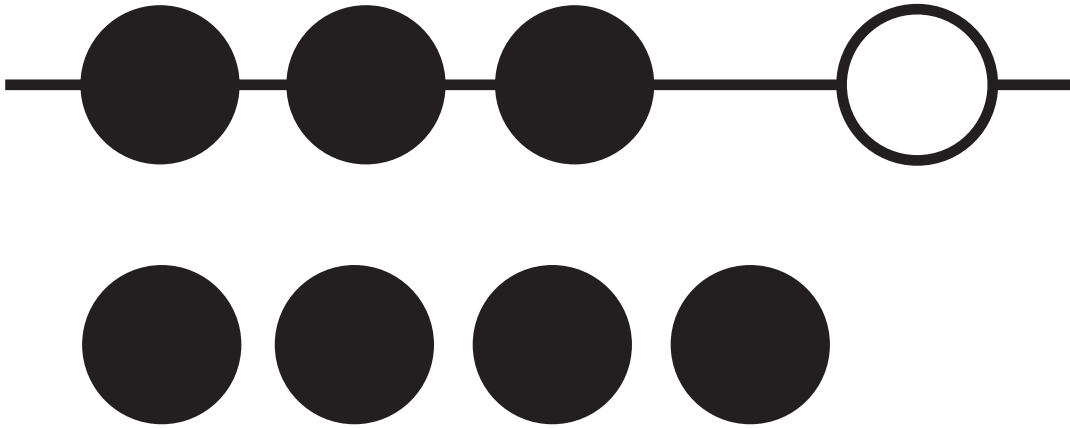

She uses this rule to work out how many black beads to use.

$$\mathbf{black = (white \times 3) + 4}$$

(a) Sarah uses 12 white beads to make a necklace.

How many black beads does she use?

(b) Sarah uses 25 black beads to make a bracelet.

How many white beads does she use?

23. The rule to find the number of faces of any pyramid is:

Number of sides of its base shape + 1

Use the rule to complete the table on the opposite page.

One has been done for you.

Name of 3D shape	Number of faces
Square based pyramid	5
Pentagonal based pyramid	
Octagonal based pyramid	

24. $\frac{1}{2} \times \frac{5}{6}$

is greater than the value of

$$\frac{1}{3} \times \frac{7}{8}$$

Explain how you know.

End of test

[BLANK PAGE]

[BLANK PAGE]



Standards
& Testing
Agency

2024 key stage 2 mathematics
Modified large print Paper 3: reasoning

Print version product code: STA/24/8819/MLp ISBN: 978-1-83507-056-7
Electronic PDF version product code: STA/24/8819/MLe ISBN: 978-1-83507-070-3

For more copies

Additional copies of this modified large print test paper can be ordered by contacting the national curriculum assessments helpline on 0300 303 3013. After the test window it can be downloaded from <https://www.gov.uk/government/collections/national-curriculum-assessments-practice-materials>.

© Crown copyright 2024

Re-use of Crown copyright in test materials

With the exception of third-party copyright content, the 2024 key stage 2 test materials are Crown copyright. You may re-use them (not including logos) free of charge in any format or medium in accordance with the terms of the Open Government Licence v3.0 which can be found on the National Archives website and accessed via the following link: www.nationalarchives.gov.uk/doc/open-government-licence. When you use this information under the Open Government Licence v3.0, you should include the following attribution: 'Contains material developed by the Standards and Testing Agency for 2024 national curriculum assessments and licensed under Open Government Licence v3.0' and where possible provide a link to the licence.



Exception – third-party copyright content in test materials

Schools and other educational establishments, as defined in the Copyright Designs and Patents Act 1988 (CDPA), may re-use the test materials in their entirety for teaching purposes: <https://www.gov.uk/guidance/exceptions-to-copyright>. However, if not expressly permitted under the CDPA, you must obtain permission from the relevant copyright owners, listed in the '2024 key stage 2 tests copyright report', for re-use of any third-party copyright content which we have identified in the test materials. Alternatively, you should remove the unlicensed third-party copyright content and/or replace it with appropriately licensed material.

If you have any queries regarding these test materials, contact the national curriculum assessments helpline on 0300 303 3013 or email assessments@education.gov.uk.