



Department
for Education

Managing Older Buildings:

A guide for estates maintenance staff

April 2024

Contents

Summary	4	Framed construction	18
Review date	4	Modern Methods of Construction (MMC) / Design for Manufacture and Assembly (DfMA)	20
Who is this publication for?	4	Appendix A: Further information on common post-war ‘system builds’	21
Revision history	5	Introduction	21
Introduction	6	Derwent	22
Additional considerations	7	Orlit	28
Part 1: A brief history of the development of the school estate	8	CLASP	31
Overview	8	Appendix B: Guide to common construction materials in school buildings	39
Late 19 th century	8	Introduction	39
Early 20 th century	8	Timber	40
Inter-war years	8	Concrete	42
Post World War II	8	Steelwork	43
Towards the Millennium	9	Masonry	44
The future of construction	9	Woodwool / Strammit	46
Part 2: Overview of common construction types in the school estate	10	Image credits	47
Traditional construction	10		
Post-war temporary accommodation (HORSA)	12		
Post-war ‘system builds’	14		
Post-war non-systemised construction	16		

List of figures

Figure 1: Example of pre-war traditional school construction.....	10	Figure 12: Service run.....	26
Figure 2: Example of a HORSAs hut	12	Figure 13: Eaves detail	26
Figure 3: Example of a post-war system build (CLASP)	14	Figure 14: Floor beam.....	27
Figure 4: Example of steel framed construction.....	18	Figure 15: Example of Orlit school accommodation	28
Figure 5: Example of concrete framed construction.....	18	Figure 16: Orlit soffit.....	28
Figure 6: Example of a completed school using MMC/DfMA.....	20	Figure 17: School constructed with CLASP.....	31
Figure 7: Example of MMC/DfMA off-site manufacture.....	20	Figure 18: CLASP axonometric.....	33
Figure 8: Example of Derwent school accommodation.....	22	Figure 19: Column/cladding details	34
Figure 9: Derwent axonometric.....	24	Figure 20: Column/beam connection	35
Figure 10: Column profile.....	25	Figure 21: Wind bracing	35
Figure 11: Column profile: tapered fin.....	25		

Summary

This publication from the Department for Education (DfE) provides non-statutory guidance on the types of construction commonly found in the school estate. It has been produced to help building users, owners and maintenance staff to identify building systems and help prioritise future maintenance and repair of their buildings.

Review date

This guidance will be reviewed no later than the end of 2024.

Who is this publication for?

This guidance is for:

- local authorities (for community, voluntary-controlled schools, foundation schools and maintained nursery schools)
- academy trusts (for academies and free schools)
- governing bodies (for voluntary-aided schools)
- school/college leaders, staff and governing bodies in; further education colleges and designated institutions, sixth form colleges, maintained schools, academies and free schools, pupil referral units, City Technology Colleges, non-maintained special schools and maintained nursery schools
- technical professionals involved in the design, construction and maintenance of school premises.

Academy trusts with a religious character and the responsible bodies for voluntary-aided and voluntary controlled schools should engage with the land/site trustees for their land and buildings and the relevant religious body, most often their Diocese.

Revision history

This table lists the key changes in each update.

ISO revision code	ISO status code	Date	Amendment
C01	A	2024-04-25	First issue of guidance

Introduction

All buildings need to be maintained and managed effectively to remain comfortable and safe. It is important that building owners, users and maintenance staff have knowledge of the construction types and materials used in their buildings. This knowledge will allow them to plan appropriate maintenance and monitor the building fabric for any early signs of deterioration. With effective maintenance most buildings continue to perform long after their intended design life.

This guidance provides information relating to the typical construction types used in the school estate, particularly those commonly used in the period between 1945 and the mid-1970s when a significant number of school buildings were constructed.

The guidance is split into two parts with two appendices.

Part 1 provides a brief history of school building in England.

Part 2 provides information about the types of construction that are typically used in the school estate. It should be read in conjunction with Appendices A and B.

Appendix A provides information about three types of 'system build' that were common in the post-war period. These forms of construction require special mention as they used evolving construction methods. Therefore, maintenance plans should consider the system as a whole as well as its constituent parts and their materials.

Appendix B provides information about the construction materials commonly used in the construction types outlined in Part 2 and the systems in Appendix A. It gives further details on the common signs of deterioration, how these should be treated in the short term and where to seek further advice.

The guidance predominantly focuses on common maintenance items for load bearing structural framing and some cladding elements. For guidance concerning the day-to-day maintenance of finishes and decoration, and the maintenance of other components in the building (e.g., heating and electrical systems), please refer to the [Good Estate Management for Schools](#).

Additional considerations

Scope of guidance

This guidance is intended to give those responsible for planning and carrying out maintenance a high-level overview of the types of construction that may be present in their estates and to help identify these common types of construction. It outlines some of the common areas that should be considered to ensure buildings remain serviceable and structural elements do not deteriorate.

It is not intended to be exhaustive, if the reader requires further information, they should consult a suitably qualified building professional who will be able to provide more detailed information which is tailored to their specific buildings, taking into account wider condition issues.

Reporting structural issues

A structural issue is a significant adverse change in the condition of a building's structure (including footings, foundations, structural portions of load bearing walls, structural floors and subfloors, primary roof structure, lift shafts, and structural columns and beams) that may cause harm or full or partial closure of a building. If you currently have any significant structural issues with your buildings, please complete this simple [DfE Structural Issues](#) form to advise the department. An official from the department will make contact once you have completed the form to discuss next steps.

Asbestos

Your school buildings may contain asbestos if any part was built before the year 2000. It is extremely important that any asbestos present in your estate is located and managed effectively.

Before carrying out any investigative work other than visual inspection, you must consult the [DfE's guidance on asbestos](#). It should be used alongside more detailed advice, such as the Health and Safety Executive's (HSE) [duty to manage asbestos in buildings](#) and [asbestos management checklist for schools](#).

Following the steps set out in this guidance should protect the health of staff, pupils, students, contractors and visitors to the estate from the risk of exposure to asbestos.

Health & Safety considerations

As well as asbestos, wider health and safety considerations should be considered when planning building maintenance. These include the safety of those carrying out the works as well as all other building users.

Building maintenance should be carried out by suitably qualified professionals and only when planned risk assessments and method statements, appropriate to the works, are in place. Depending on the scale of the works being undertaken, they may need to be comply with the [Construction \(Design and Management\) Regulations 2015](#).

Part 1: A brief history of the development of the school estate

Overview

The school estate in England comprises around 64,000 teaching blocks across over 22,000 schools. The size, age of buildings and type of construction varies considerably across the estate.

The following sections show how wider educational policy and social factors affected the types of construction used.

Late 19th century

Education became compulsory for children aged between 5 and 10 years of age in 1880 and up to the age of 12 by 1899. This resulted in a surge in demand for new school buildings. Schools constructed in this period were commonly 3 or 4 storeys high to fit the necessary accommodation on tight, urban sites. Generally, they were constructed in brick and had steep pitched roofs and large timber sash windows.

Early 20th century

Under the 1902 Education Act responsibility for school buildings fell to local authorities (LAs). A falling birth rate led to a decline in building elementary schools, with new schools mainly

concentrated in the expanding suburbs. Concerns about children's health led to calls for better daylighting and ventilation, and access to fresh air. This started a move away from planning classrooms around central halls to more linear arrangements, with classrooms connected by long, broad corridors or external, covered verandas.

Inter-war years

A lack of school places immediately after the First World War was further exacerbated by a steep increase in the birth rate during the 1920s and a shortage of building materials, labour and funding. As a result, many emergency classrooms were created using buildings originally designed to be wartime huts.

Due to the economic situation in this period, the Baines Committee recommended in 1925 to build school buildings more economically, suggesting that halls and corridors be reduced in size and roofs built to a lower pitch.

Post World War II

There was an urgent need for school building in the period immediately after World War II (WWII). One in five schools in England had been destroyed or badly damaged and there was a rising birth rate. Furthermore, the school leaving age was raised from 14 to 15 years in 1947 as part of the 1944 Education Act which made secondary schooling a statutory requirement.

The unprecedented demand for new school places, alongside post-war shortages of materials and labour, led to the Hutting Operation for the Raising of School-Leaving Age (HORSA huts), which lasted from 1944 to 1950. These were temporary buildings and are covered in more detail in Part 2 of this guidance.

While HORSA huts had met an immediate need, material shortages continued in the years after the war. Expenditure cuts led to all LAs being required to produce carefully costed, 3-year building plans. To achieve cost savings, a series of prefabricated 'industrialised' systems came to the market. These used innovative techniques to minimise material costs and construction times. In the 20 years following the war, up to 80 different 'system-builds' were developed using a variety of steel, timber or precast concrete frames with lightweight cladding panels and partitions.

By the mid-1970s some shortcomings in school building systems were becoming apparent. They had not achieved the economies sought and emerging technical issues were causing concern. Local authorities started looking at other options, using steel frames or traditional materials, and by the mid-1970s load bearing brickwork became almost universal in school building. However, 'system builds' had achieved some significant success in standardising an approach to school building design and provided good quality education space for thousands of pupils.

Towards the Millennium

The 1900s and 2000s saw a significant change in how school buildings were owned, and new schools delivered. For almost a century, schools had been owned and run by local authorities. This changed with the introduction of academy trusts who were independent from local authorities and responsible for the maintenance of school buildings. As well as locally delivered schools, the Department for Education also began delivering construction projects, most recently through the department's own centralised programmes such as free schools, Priority School Building Programme and the School Rebuilding Programme.

The future of construction

In recent years, with continued productivity, supply and resource constraints, government initiatives have promoted the use of Modern Methods of Construction (MMC). MMC solutions range from panelised components to full volumetric 'modular' solutions. Limited by transport constraints, full volumetric MMC solutions are often better suited to cellular spaces such as classrooms.

Part 2: Overview of common construction types in the school estate

Traditional construction

Overview

The term 'traditional construction' is used for buildings with load bearing masonry walls (usually brick), timber (occasionally concrete) floors and timber pitched roofs clad with tiles or slates. Traditional construction has been used for hundreds of years and is still in use today. Traditional construction was the mainstay for school buildings until WWII. The information in this section specifically relates to pre-WWII construction.

Cavity wall construction became increasing widespread from the 1930s. Masonry walls prior to this period were typically solid brickwork. Solid brickwork can usually be identified by the brick patterns used in the walls, with 'headers'¹ evident. It is important that walls are kept in good condition as otherwise water can penetrate causing deterioration of the masonry, supported members and the building fabric more widely.

Timber has always been seen as an inexpensive and easily accessible construction material, although timber shortages and

¹ A brick that is laid flat and perpendicular to the wall's face.

forestry prices caused by both world wars limited the potential for widescale structural use.

Keeping timber dry is paramount to its durability. It is particularly susceptible to damage where it meets external materials. Damage can also occur at connections between timber and other structural members, or where structural timber has been notched or drilled to accommodate building services.



Figure 1: Example of pre-war traditional school construction

Structural summary

Vertical load bearing elements

In smaller spaces (e.g., classrooms and offices), timber floorboards typically span across timber floor joists which are commonly built into recesses (or ‘pockets’) within load bearing masonry walls. For larger open spaces (e.g., halls), timber floor joists may be supported by iron or steel beams. In some cases, iron or steel may have been used as isolated columns, although load bearing masonry walls are more common.

Lateral stability

As well as supporting vertical loads (i.e., the weight of structural materials, building occupants etc), masonry walls are required to support loads applied by wind. It is therefore crucial that any new holes or openings being formed in walls (e.g., for windows) are checked by a qualified building professional.

Common foundation types

The type of foundations will depend on the type of soil under the building(s). However, these are likely to be at a shallow depth as brick or concrete ‘strips’.

Common material types and maintenance items

The following materials are commonly found in school buildings that use traditional construction:

- masonry
- timber
- iron/steelwork
- concrete

For traditional construction the following areas should be given special consideration for targeted maintenance:

- stability of chimney stacks or parapets
- condition of brickwork pointing
- location and condition of damp-proofing
- mechanical damage to timber joists
- overloading of timber floors

Further details are available in Appendix B.

Further information (external links)

- [Historic Structural Steelwork Handbook](#)
- [Historic England Looking After Historic Buildings](#)

Post-war temporary accommodation (HORSA)

Raising the age that children left school and the need for rapid rebuilding in urban areas after the war led to the Hutting Operation for the Raising of the School-Leaving Age (HORSA) policy. HORSA buildings were distinctive one storey prefabricated constructions that were used for education. These were intended to be temporary buildings constructed in concrete and timber, with metal windows and corrugated asbestos roofs. They are sometimes referred to as Pratten Huts as they were commonly supplied by F. Pratten and Co Ltd.

At the time of construction, concrete often inadequately covered steel reinforcement, leaving a potential for the reinforcement to corrode over time and result in the 'spalling'² of the concrete. Similarly, poor detailing left timber elements prone to deterioration due to frequent exposure to moisture (e.g., condensation) and/or the elements.

HORSA huts are beyond their expected lifespan and require careful maintenance.



Figure 2: Example of a HORSA hut

² Spalling refers to the process of surface failure due to large shear stresses under the surface caused (in this case) by corroding steel reinforcement.

Structural summary

Vertical load bearing elements

Roof sheets, sometimes constructed of asbestos, are supported by roof beams, commonly formed of timber. The roof structure is supported on the perimeter walls, which are typically concrete and in some cases timber stud work.

Lateral stability

As well as supporting vertical loads (i.e., the weight of the roof and potential snow loads etc), the concrete panel walls are required to support loads applied by wind.

Common foundation types

As these temporary buildings were single storey, they would commonly have been founded on very shallow foundations, most likely concrete trenches and potentially, no foundations at all.

Common material types and maintenance items

The following materials are commonly found in HORSAs buildings:

- concrete
- timber
- asbestos

For post-war HORSAs buildings the following areas should be given special consideration for targeted maintenance:

- management and risk assessment of asbestos – refer to link under ‘Further information (external links)’ below
- deterioration of timber elements due to water damage (either from water penetration or condensation)
- deterioration of concrete elements due to water damage (either from water penetration or condensation)

Further details are available in Appendix B.

Further information (external links)

- [Designing Buildings: HORSAs hut](#)
- [GOV.UK Guidance on managing asbestos in your school or college](#)

Post-war 'system builds'

Overview

Numerous forms of prefabricated school building systems were developed after WWII. The demand for replacing war-damaged buildings and for school places due to the soaring birth rate led to a boom in 'system build' construction.

The term 'system builds' is commonly used for these post-war prefabricated buildings. Manufacturers developed bespoke systems comprising a mixture of concrete, steel and timber elements. There was a significant drive to off-site, industrialised, manufacturing and improved on-site construction speeds.

'System build' manufacturers were either:

- private firms: developing their systems for housing and then adapting them for other building types
- 'consortia' of local authorities: developing systems which allowed efficient delivery due to economies of scale

In some cases, the consortia developed a single system, for example CLASP (with its distinctive bracing design). In other cases, they developed a range of solutions using different materials, for example SEAC (steel, concrete and masonry systems). Private suppliers included Orlit and Derwent (also known as Vic Hallam). Further details of these systems are provided in Appendix A.



Figure 3: Example of a post-war system build (CLASP)

Structural summary

Vertical load bearing elements

The vertical load bearing elements varied depending on the system being used. Appendix A provides further information on some of the common types of system, allowing the reader to identify whether they have a system build and potential areas where maintenance should be focused.

Lateral stability

The elements required to provide horizontal stability varied depending on the system being used. Again, Appendix A provides further information on some of the common types of system, allowing the reader to identify whether they have a system build and potential areas where maintenance should be focused.

Common foundation types

The foundation type(s) will depend on the ground conditions present on the site. Some systems had bespoke foundations to suit the expected ground conditions in the areas where the consortia were based. For example, foundations to CLASP buildings were designed to accommodate movement due to mine workings.

See Appendix A for system specific foundation details.

Common material types and maintenance items

The following materials are commonly found in school buildings that use post-war 'system builds':

- masonry
- timber
- lightweight steelwork
- concrete

For post-war 'system builds' the following areas should be given special consideration for targeted maintenance:

- cracking or movement at joints between precast concrete panels
- timber elements for signs of deflection (bowing)
- rust or corrosion of steelwork elements

Further information about specific systems can be found in Appendix A, information concerning common materials can be found in Appendix B.

Further information (external links)

- [Historic England: Historic School Buildings](#)
- [Historic England: England's Schools 1962-88](#)

Post-war non-systemised construction

Overview

In the late 1960s and early 1970s, many consortia began to disband. By the mid-1970s there was mostly a return to traditional construction methods which commonly used masonry walls. However, CLASP and other systems were still being developed and produced.

New and innovative materials were also in use, primarily for floors as alternatives to traditional timber construction. Products such as Orlit, Bison and other precast concrete forms, as well as woodwool, were used for floors as well as flat and occasionally pitched roofs.

Masonry buildings typically comprised cavity wall construction, whereby two 'leaves' of brickwork are built with a small, predominantly 50mm at the time, gap between them to improve the insulation properties of the wall when compared to earlier solid brick walls. Masonry leaves were tied together using steel ties which latterly became stainless steel to avoid problems with rusting/corrosion.

These non-systemised buildings were designed by several engineers and architects meaning their shape and appearance vary. However, the majority consist of rectangular blocks with flat roofs.

Structural summary

Vertical load bearing elements

The floor and roof construction of these buildings vary. In some cases, timber plywood sheets spanned across timber joists onto steel beams. In other cases, precast concrete panels were supported by steelwork. In many cases, load bearing masonry cavity walls support the floors and roofs directly.

Lateral stability

The masonry walls to the perimeter of the building and internal 'cross walls' resist the loads applied by wind. It is therefore crucial that any new holes or openings being formed in walls are checked by a qualified building professional.

Common foundation types

Foundations will be designed to suit the ground conditions present on the site. Given that load bearing masonry is not a lightweight construction, buildings more than one storey, or on soft ground may have deeper, piled foundations.

Common material types and maintenance items

The following materials are commonly found in school buildings that use post-war non-systemised construction:

- masonry
- timber
- concrete
- woodwool (Strammit)

For post-war non-systemised buildings, the following areas should be given special consideration for targeted maintenance:

- bulges or distortion of masonry walls which may indicate inadequate walls ties
- signs of water ingress, particularly around flat roofs or perimeter walls/parapets

Further details are available in Appendix B.

Further information (external links)

- [NHBC House Building Standards 2024](#)³

³ Note – these are the current standards for masonry in housebuilding. While the details may not be directly applicable to post-war non-systemised

Reinforced Autoclaved Aerated Concrete

Reinforced Autoclaved Aerated Concrete (RAAC) was produced in the UK between the 1950s and early 1980s and was used in some post-war non-systemised construction. It is a lightweight, 'bubbly' form of concrete predominantly found as precast panels in roofs (mostly flat, sometimes pitched) and occasionally in floors and walls.

The DfE completed its identification programme, which asked all Responsible Bodies (local authorities, academy trusts, dioceses, and further education colleges) to look for RAAC in their buildings.

If you believe that a premises may contain RAAC or if you are unsure, you should seek assistance from an appropriately qualified building surveyor or structural engineer with experience of RAAC identification. If RAAC is confirmed to be present, and you are a responsible body for a state-funded education setting in England, you should inform the DfE using the [DfE Structural Issues](#) form. An official from the department will make contact once you have completed the form to discuss next steps.

construction, they give an indication of the details and construction that could be identified during inspection.

Framed construction

Overview

Framed construction became increasingly popular in the school estate in the late 20th and early 21st century. This form of construction allows greater flexibility of internal spaces and less repetition in the external appearance of buildings.

In framed construction, the external cladding is generally non-load bearing so could comprise materials other than brick.

The use of discrete load bearing columns and lightweight, non-load bearing partitions, means internal layouts can be altered to suit future changes in educational practices without the need for significant structural alteration. The use of framed construction also gives the opportunity to introduce larger atria and double height spaces in circulation areas.



Figure 4: Example of steel framed construction



Figure 5: Example of concrete framed construction

Structural summary

Vertical load bearing elements

Concrete framed buildings typically comprise floors and roofs formed of concrete, either as precast panels or in-situ slabs.

Floors of steel framed buildings typically have precast concrete slabs or in-situ concrete poured onto a profiled metal deck. In some cases, roofs are lightweight profiled metal deck, and in older buildings may have been formed using woodwool (Strammit) panels. Further details are available in Appendix B. In both steel and concrete framed structures, the floors and roofs are supported by discrete columns.

Lateral stability

Wind loads are commonly resisted by 'bracing' elements. In concrete frames, these are likely to be concrete 'shear' walls. In steel framed buildings, these may be diagonal bracing. Should further information be needed about the type of lateral stability of a building you should contact a suitably qualified and experienced chartered engineer who will be able to advise.

Common foundation types

The foundation types will depend on the size and layout of the building as well as the ground conditions present on the site. Should you require further information about a building's foundation you should contact a qualified building professional who will advise whether any on-site investigations are needed.

Common material types and maintenance items

The following materials are commonly found in school buildings that use framed construction:

- steel
- concrete
- masonry
- timber

For framed construction the following areas should be given special consideration for targeted maintenance:

- signs of water ingress e.g., through flat roofs
- gutters and downpipes being clear, so rainwater is directed away from the building
- flashings, roof coverings etc., are not damaged, especially after adverse weather
- signs of cracking or movement in façade panels

Further details are available in Appendix B.

Further information (external links)

- [Cross UK: Collaborative Reporting for Safer Structures UK](#)
- [Concrete Building elements](#)
- [Designing Buildings](#)

Modern Methods of Construction (MMC) / Design for Manufacture and Assembly (DfMA)

Overview

MMC/DfMA is a collective term used to describe construction practices that are alternative to traditional building. It focusses on the use of off-site construction techniques within factory settings to produce building components for transportation to, and assembly on, site. It includes:

- preformed panels (typically steel or timber) which are connected on site to form walls, floors and roofs
- preformed 'volumetric' units i.e., 'boxes' with some or all components already installed which are bolted together on site
- hybrid techniques that combine the above

MMC/DfMA cover a wide range of construction materials and practices which are beyond the scope of this document. Please refer to the links in 'Further information (external links)' below for more details.

Further information (external links)

- [MMC Definition Framework](#)
- [GOV.UK: The Construction Playbook](#)
- [Go Construct: Modern Methods of Construction \(MMC\)](#)



Figure 6: Example of a completed school using MMC/DfMA



Figure 7: Example of MMC/DfMA off-site manufacture

Appendix A: Further information on common post-war 'system builds'

Introduction

This appendix provides information about the typical features that can be used to identify the most common types of post-war 'system build' in the school estate.

Based on the information in this appendix, the reader should be able to identify if they have buildings of these types and then use the visual guides to identify areas that should be given special attention and consideration for targeted inspection and maintenance.

Derwent



Figure 8: Example of Derwent school accommodation

Background

In the 1950s, Morrison Design Architects were invited by Derbyshire County architect, Hamer Crossley, to design a new school utilising an Austrian system concept of timber prefabrication. They proposed a UK based timber panelised construction which could be used across the country.

Uses: Primarily schools. Variations include offices, clinics, hostels, libraries, gymnasia, community, health & welfare centres

Structural frame type: Timber

Approximate years of manufacture: 1952 - 1963

Manufacturer: Vic Hallam Ltd, Nottingham

Architect: Morrison Design

Known locations (though likely to exist elsewhere): Over 30 regions including Sheffield, Birmingham, Yorkshire, Essex, Derbyshire, Lancashire, Nottinghamshire and Warwickshire

Identifying Derwent construction

Foundations	Vary to suit ground type/conditions
Ground floor	Concrete
Upper floors	Timber plywood on battens
Roof	Timber plywood on battens with 12° pitch
Vertical structure	Timber columns with some load bearing timber panels
Horizontal stability	Infill timber panels
Planning grid	6' 4" (1,930mm)
Structural grid	6' 4" (1,930mm)
Planning height	1' 4" (406mm)
Typical column size	4" (102mm)
Typical beam size	Varies

Features and common maintenance items

The sketch below outlines the defining characteristics of a Derwent building and indicates where inspection should be carried out to identify common maintenance items with this construction type. The items shown should be cross referenced against Part 2 and Appendix B of this document.

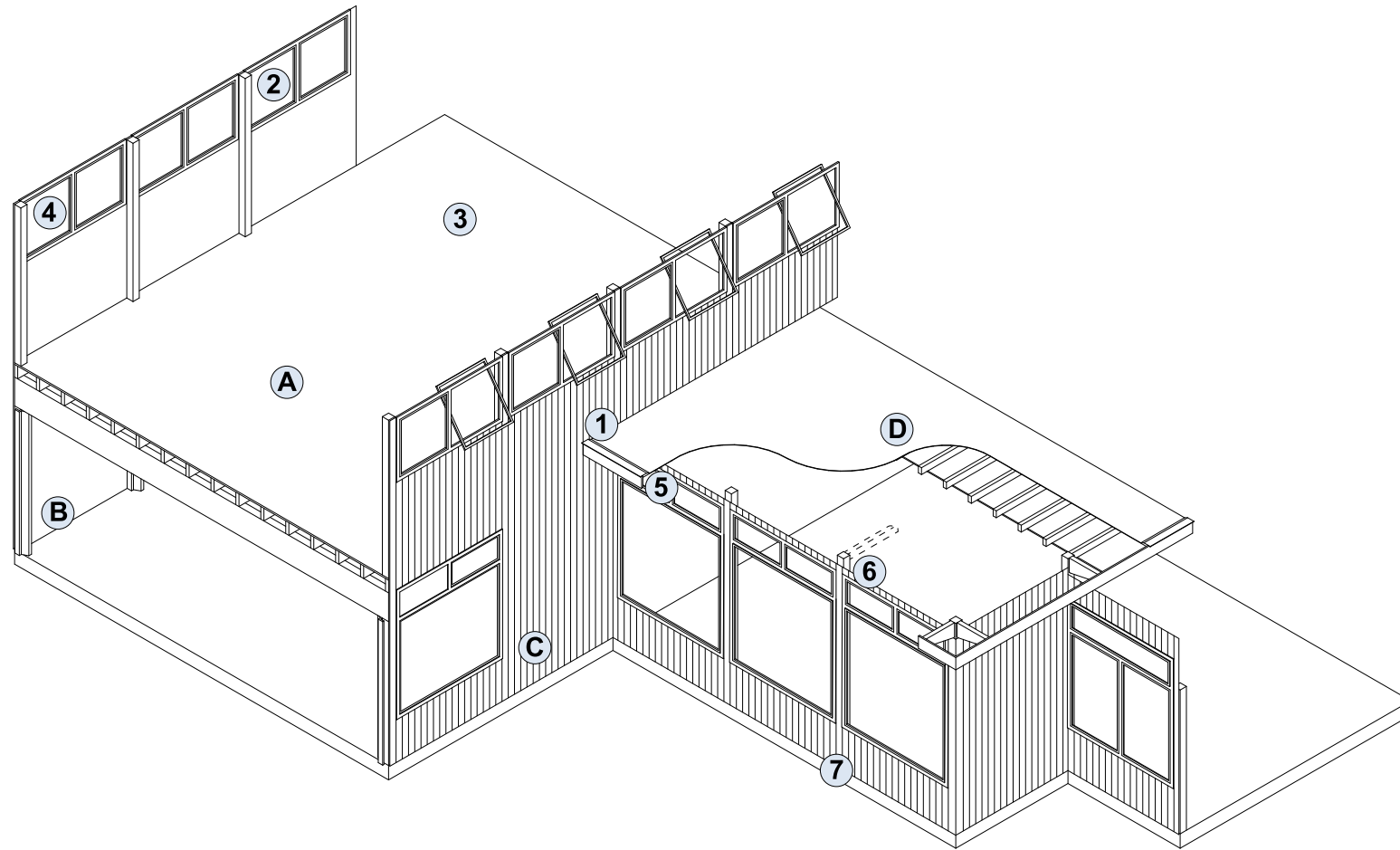

Identifying features:

- 1 Cladding materials: vertical timber boarding, brick, stonework and sheet materials (e.g., plywood)
- 2 Panel module: 6' (1.8m) panel width and 4" (100mm) column
- 3 Plywood sheathing
- 4 Column details - see overleaf
- 5 500mm overhanging eaves
- 6 Column roof purlin connection
- 7 Indicative location of column base

Common considerations:

- A Decay of columns leads to movement of beams and uneven floors
- B Wet rot at base of column due to water ingress
- C Decay of timber columns can lead to column failure, distortion of external elevations and bulges in the exterior timber cladding
- D Wet rot to roof structure due to water ingress

Figure 9: Derwent axonometric

Typical details and common maintenance items

Column profile:

Columns on the ground floor of a single storey building and first floor of a two-storey building are formed from small timber sections, typically four no. 4" x 1" timbers and are susceptible to decay.

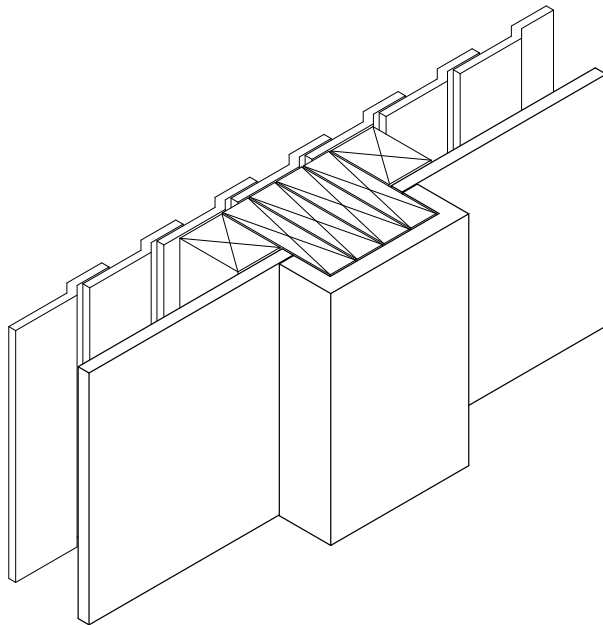

Figure 10: Column profile

Column profile with tapered fin:

Columns on the ground floor of a two-storey building are likewise formed from small timber sections and have an additional tapered fin attached to the main column to support the first-floor beam.

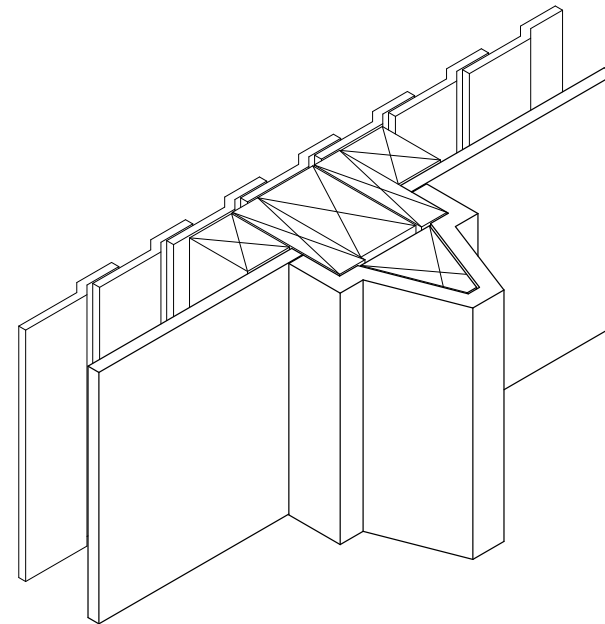

Figure 11: Column profile: tapered fin

Service run identifying feature:

Service wire route passes from behind the skirting, up through a continuous hollow service run within the timber column and roof purlin construction.

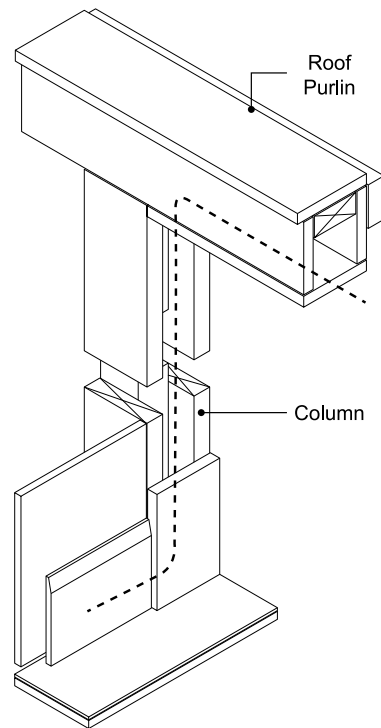

Figure 12: Service run

Eaves detail identifying feature:

Typical 500mm overhanging eaves with timber fascia, external rainwater pipes and $\frac{3}{16}$ " plywood soffit.

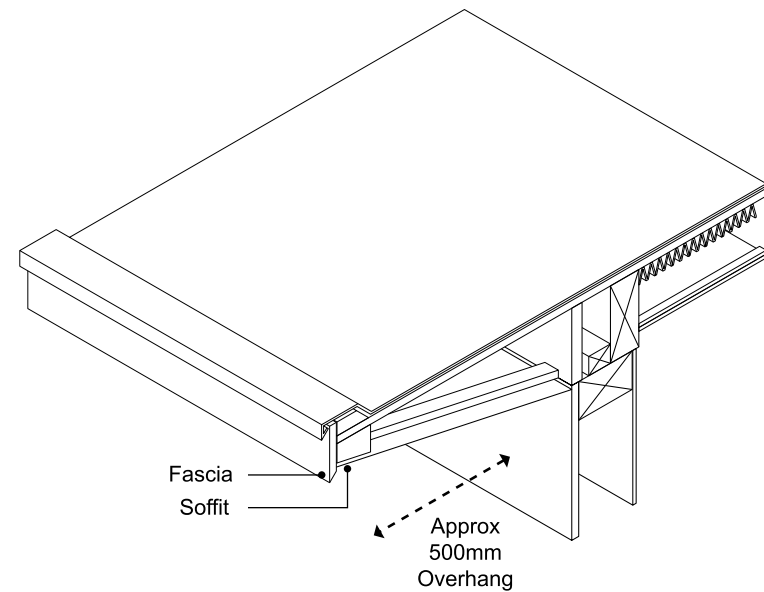

Figure 13: Eaves detail

Floor beam: typical identifying feature:

Solid laminated timber floor beam with cross battens supporting plywood floor. Cellular plasterboard soffit secured to underside of battens and beams encased with fibrous plaster to provide 30-minute fire protection.

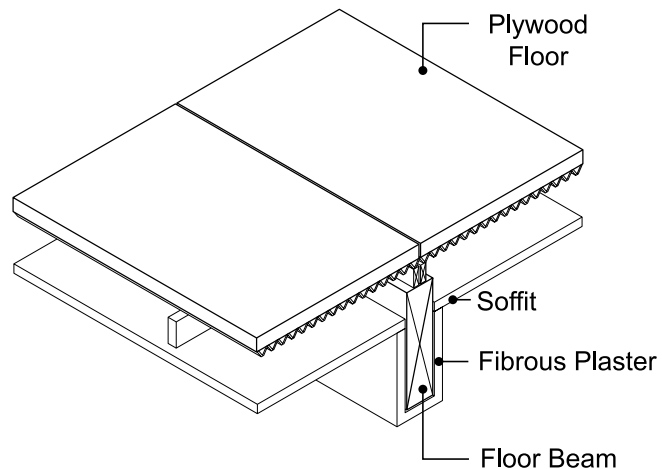

Figure 14: Floor beam

References and further information

- [Morrison Design Architects Website](#)
- System building: the 'Derwent' system of Vic Hallam Ltd: RIBA Journal 1969 July, p287-291
- Sheffield sparks Derwent system alert: Architects Journal 1987 Oct 21, p13
- The Derwent System of Construction: Vic Hallam Oct 1972
- The Derwent system of building: Prefabrication, Vol.2, May 1955, p311-317
- Derwent construction for schools: The Architect and Building news, 5 Aug 1954, p151-161

Orlit



Figure 15: Example of Orlit school accommodation



Figure 16: Orlit soffit

Note: Slabs are not always imprinted with 'Orlit'.

Background

Orlit was the design concept of Czech architect, Erwin Katona. It was originally designed as a precast concrete framed structure for housing, and externally clad with 2-inch reinforced concrete hollow blocks. Orlit houses are classified as ‘defective’⁴ in England and Wales and have typically been subject to extensive repairs or demolished.

Uses: Primarily houses and flats. Known variations include schools, libraries, health centres, civic buildings, factories, church halls and offices

Structural frame type: Precast reinforced concrete

Approximate years of manufacture: 1940s & 1950s

Manufacturer: Orlit Ltd, Vicarage Road, Egham, Surrey

Architect: Erwin Katona

Known locations (though likely to exist elsewhere):

Birmingham, Brighton & Hove, Bromley, Coventry, Croydon, Essex, Hackney, Havering, Kent, Lancashire, Lincolnshire, London, Newcastle, Redbridge, Somerset, Stoke on Trent and Woolwich

⁴ The Housing Defects Legislation (now Part XVI of the Housing Act 1985).

Identifying Orlit construction

Foundations	Concrete
Ground floor	Concrete
Upper floors	Timber plywood on battens, on secondary concrete beams
Roof	Precast concrete slabs on precast concrete secondary beams, with screed to falls and asphalt or bituminous felt covering. Pitched roof option: timber or steel structure, tiled finish
Vertical structure	Precast concrete columns
Horizontal stability	Precast concrete secondary beams or (where there is a concrete floor) precast inverted channel floor slabs
Planning grid	Variable
Structural grid	Columns at 10’ (3.050m) or 12’ (3.660m) centres
Planning height	Variable
Typical column size	5½” square (140mm)
Typical beam size	Primary: 8” depth (200mm) Secondary: 7” x 4” (178 x 102mm) at 4’ (1220mm) centres

Typical details and common maintenance items

Structure

Precast reinforced concrete columns at either 10' (3.050m) or 12' (3.660m) centres and beams.

Maintenance items include:

- structural weakness due to cracked main and secondary beams and columns, caused by reinforcement corrosion (this is generally associated with flat roof forms)
- failure of column/beam connections, generally due to condensation

Cladding

Precast concrete facing slabs 4' wide x 1' 4" high (1220mm wide x 405mm high) and 2' wide x 1' 4" high (610mm wide x 405mm high). Factory finished with various textures and colours. Other types of cladding may also have been used.

Maintenance items include:

- cracking and spalling of concrete cladding, and other non-structural components

Internal cladding/leaf

Lightweight 2½" (64mm) thick concrete blocks.

Floors

Timber plywood on battens, on secondary concrete beams. Or, where there is a concrete floor, precast concrete inverted channel floor slabs.

Roof

Precast concrete slabs 4' x 1' x 2" thick (1220mm x 305mm x 50mm) on precast concrete secondary beams, with screed to falls and asphalt or bituminous felt covering.

Pitched roof option: timber or steel structure with a tiled finish.

Common maintenance items:

- flat roof construction susceptible to condensation leading to deterioration of the high alumina cement joints

References and further information

- The structural condition of Orlit houses: BRE Report 1983
- [Orlit House](#)
- Deterioration and repair of prefabs: RIBAJ 1984 vol 91, no.2 Feb, p60
- Non-traditional housing in N. England, NCHA

CLASP



Figure 17: School constructed with CLASP

Background

CLASP is the first example of a group of local authorities forming a voluntary consortium to develop and control a system of construction for their own use. Founder members were the City of Coventry, Derbyshire County Council (CC), Durham CC, Glamorgan CC, West Riding of Yorkshire CC, the City of Leicester and Nottinghamshire CC. CLASP was considered particularly useful in coal mining areas at risk from mining subsidence where it provided schools at little extra cost. As the design evolved over the years, new 'Marks' (Mks) were released (see CLASP Marks, pages 36 - 38).

Uses: Houses and flats, schools, libraries, health centres, civic buildings, factories, church halls and offices

Structural frame type: Pin jointed steel

Approximate years of manufacture: 1957 - 2005

Manufacturer: Blockhouse Steel Structures Ltd

Architect: Donald Gibson (Nottinghamshire CC), further developed later with Charles Aslin (Hertfordshire CC)

Known locations: There are over 1,400 CLASP schools in the UK, distributed among 89 Children's Services Departments. Independent schools own a small number of CLASP buildings

Identifying CLASP construction:

Foundations	Concrete
Ground floor	Screed on concrete slab and floor finish (woodblock or plastic tiling)
Upper floors	1½" x 4" (38 x 102mm) t&g timber boarding spanning 3' 4" (1016mm) between steel secondary beams
Roof	Prefabricated timber panels - ¾" thick (19mm) on 5" x 1½" (127 x 38mm) and 4" x 2" (102 x 51mm) joists, and 3 layers bituminous felt with ½" (13mm) gravel
Vertical structure	Cold rolled steel strip welded to form box sections
Horizontal stability	Steel primary beams, secondary beams (welded lattices of hot-rolled and cold-rolled angle sections with flat lower chord) and diagonal ties (fixed and cold rolled steel or spring-loaded units)
Planning grid	Horizontal: 3' 4" (1016mm), vertical: 4" (102mm)
Structural grid	Column centres at 3' 4" (1016mm) or multiples thereof
Planning height	Stanchions: 10' (3048mm) to 24' (7315mm) in 2' (610mm) increments
Typical column size	4½" x 4½" (114mm) square steel sections
Typical beam size and span	Spans from 3' 4" (1,016mm) to 26' 8" (8,128mm)

Features and common maintenance items

The sketch below outlines the defining characteristics of a CLASP building and indicates where inspection should be carried out to identify common maintenance items of this construction type. The items shown should be cross referenced against Part 2 and Appendix B of this document.

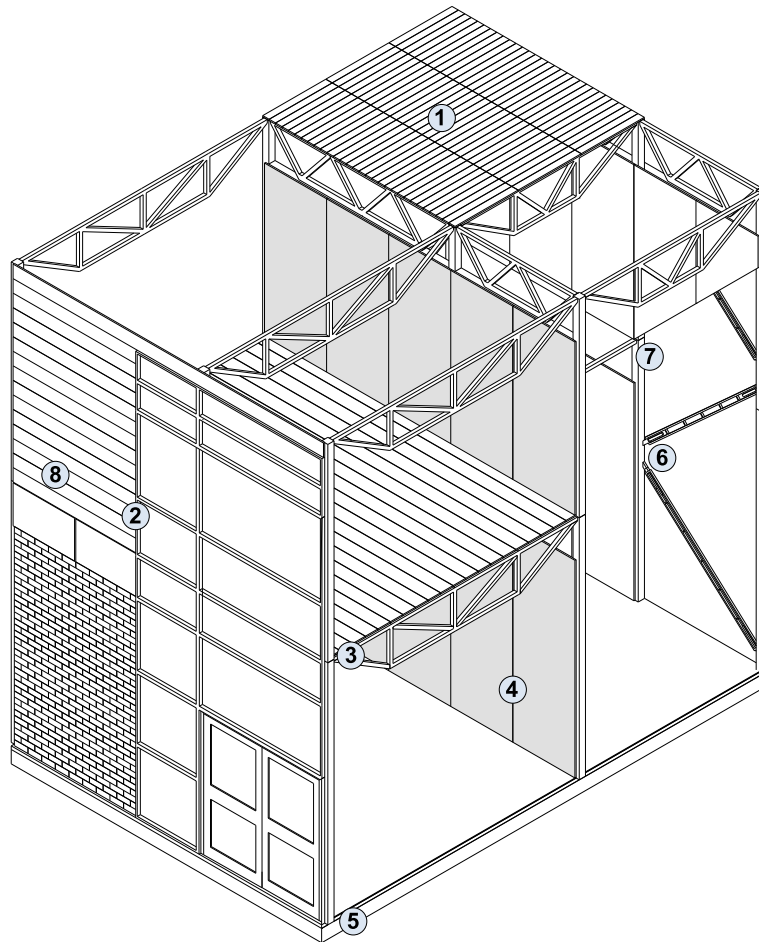

Identifying features:

- 1 Roof: prefabricated timber panels formed of $\frac{3}{4}$ " boards nailed to joists with 3 layers bituminous felt & $\frac{1}{2}$ " gravel chippings
- 2 Window cills set at 2', 2' 8" or 3' 4" above finish floor level (FFL). Transoms and door heads at 6' 8" above FFL
- 3 Floor finish: $1\frac{1}{2}$ " x 4" t&g boarding spanning 3' 4" between steel secondary beams
Consideration: Rotten timber floors and roofs, particularly in earlier Marks
- 4 Partition walls of prefabricated plasterboard units consisting of 2 sheets plasterboard and a paper core (overall thickness $2\frac{1}{4}$ "). Other options include: Parana pine boarding, hardboard, asbestos board
- 5 Column bases cast at intervals of 3' 4" (or multiples of)
- 6 Spring loaded windbracing
- 7 Column beam connection
- 8 Outer cladding typically formed of either pre-cast concrete units (thickness varying from $2\frac{1}{2}$ " at ribs and edges to $1\frac{1}{4}$ " in the centre), clay tiles, horizontal timber boarding or corrugated aluminium sheets

Figure 18: CLASP axonometric

Typical details and common maintenance items

Common maintenance items:

Asbestos containing materials (ACMs) are found in many locations including boarding around steel members, shuttering, packers and panels, service ducts, pipe lagging, cisterns, duct covers, blind boxes to the window frames and floor coverings.

Asbestos fibres can escape from:

- poor seals at joints or gaps in column casings when subject to impact e.g., by furniture or closing an adjacent door
- disturbance caused by minor works e.g., cabling, replacing windows etc
- unsealed column tops in ceiling voids
- asbestos debris left in columns, external wall cavities and ceiling voids

Alterations to the slab and structural frame will have a significant impact on structural integrity.

Acoustic and thermal performance is difficult to upgrade, underfloor insulation is generally not possible.

Timber floors and roofs, particularly of earlier Marks, are susceptible to rot and may require total replacement.

Windows tend to be ill-fitting.

Column/cladding detail identifying feature:

Outer cladding secured via battens to cladding frame. Cladding typically formed of either precast concrete units (1' 4" (400mm) high and available in various textures and colours), clay tiles, horizontal timber boarding or corrugated aluminium sheets. Cladding frame formed from 5⁵/₈" x 1¹/₂" (143 x 38mm) softwood sections, available in 6' (1,830mm) and 9' 4" (2,845mm) widths.

Columns set within cladding; considerations include cracking in external cladding and uneven floors.

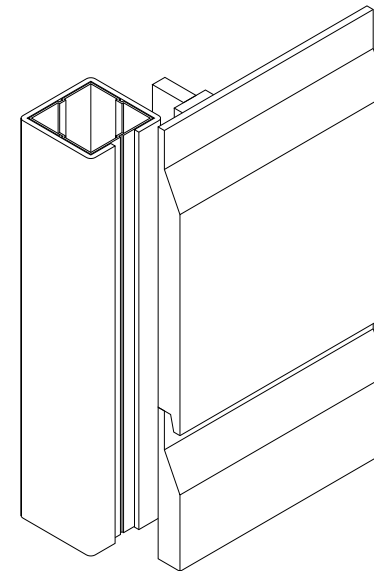

Figure 19: Column/cladding details

Column/beam connection identifying feature:

The structural framework is composed of pin-jointed steel columns, beams and diagonal ties. Steel columns are formed from 4½" x 4½" (114 x 114mm) cold rolled steel angle sections welded to form box sections. Steel beam connection plates are welded to columns.

Considerations include failure of column/beam connections.

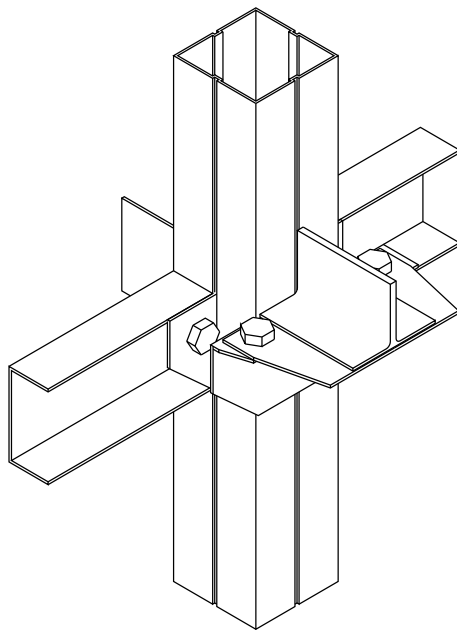

Figure 20: Column/beam connection

Wind bracing identifying feature:

Spring loaded steel bracing incorporating a pair of heavy coil compression springs was unique to CLASP. This is generally concealed within external walls and partitions but is occasionally exposed.

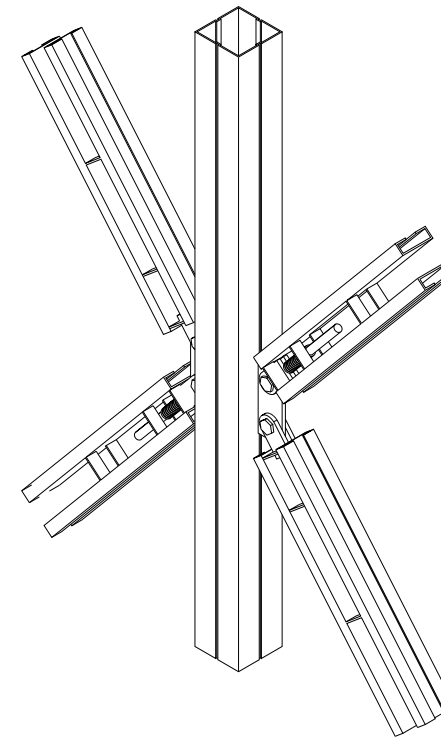

Figure 21: Wind bracing

CLASP Marks: Identifying characteristics

CLASP Mk 1: 1958/60

Mark 1 was not an official name. The system was at an early stage of development with each authority producing their own drawings. Characteristics include:

- Maximum storeys: 3.

CLASP Mk 2: 1958/60

Mark 2 was the first official designation. Characteristics include:

- Cladding: Horizontal concrete panels: 1' 4" (406mm) or 8" (203mm) high and 6' 8" (2,032mm) or 10' (3,048) wide; and tile hanging.
- Roof eaves: Projecting eaves with timber fascia; external rainwater pipes; aluminium pressing incorporating drip secured to top of fascia.
- Windows: Good quality painted timber windows. Top hung vents with some louvres also available.
- Ceilings: Fibrous plaster tiles and plasterboard.

CLASP Mk 3: 1960/62

Characteristics include:

- Cladding: Early Mark 3 concrete cladding units were as Mark 2. Late Mark 3 concrete cladding units were either 3' 4" (1,016mm) or 2' 8" (812mm) wide by 2' (610mm) high.

Tiles were commonly used for cladding with a wide range of tiles available.

- Roof eaves: Timber fascia is now set back in line with face of building with aluminium angle secured to top of fascia and external rainwater pipes.
- Windows: Horizontal sliding windows in mill finish aluminium.
- Ceilings: Fibrous plaster tiles and plasterboard as Mark 2, with Asbestolux as an option.
- Partitions: Asbestolux an option, mainly as internal lining to external walls.

CLASP Mk 3B: 1962/65

Mark 3B is similar to Mark 3. Main differences are in steelwork design, including the introduction of a cambered, or slightly arched, roof truss to provide a fall for rainwater, and a better range of windows. Characteristics include:

- Cladding: 2' (610mm) high concrete units introduced, width 3' 4" (1,016mm) or 2' 8" (812mm). Tile hanging, timber boarding and profiled aluminium sheet also available.
- Windows: As Mark 3, except louvres replaced by top hung vents.
- Roof: Cambered roof truss introduced to provide fall. At the eaves, an extruded aluminium section was used as the edge trim to top of fascia, replacing the simple aluminium angle.

CLASP Mk 4: 1965/69

Typically used for residential university buildings where smaller rooms needed. Characteristics include:

- Module: 4" (102mm) module used but in multiples of 9 (i.e., 3' (915mm), 6' (1,830mm) etc). An additional 1' (305mm) unit was available.
- Maximum storeys: 4.
- Structural floor zone: 2' (610mm).
- Ceilings: Mineral fibre tiles, plasterboard or Asbestolux. Tiles: Typically 2' x 4' (610 x 1220mm).
- Cladding: Vertical format concrete cladding unit, 8' (2,438mm) or 10' (3,048mm) high (storey heights) by 2' (610mm) wide with 1' (305mm) and 3' (915mm) options. Other sized units for under cills, eaves and floor fillers. Tile hanging and timber boarding continue to be used.
- Partitions: Asbestolux used as an internal lining to window units.
- Door frames: Stove enamelled steel.

CLASP JDP: 1968-

Designed for higher education as well as primary and secondary schools. Characteristics include:

- Structure: Hot rolled steel and precast concrete.
- Maximum storeys: 6.

- Suspended floor structure: Precast concrete deck spanning 6' (1,829mm) on a fabricated lattice of steel main and secondary beams.
- Columns: 6" (152mm) and 8" (203mm) square, cross section reduced to 4½" (114mm) square at connection with beams. Column free bays under floors of 12' x 30' (3,658 x 9,144mm) or 18' x 24' (5,486 x 7,315mm).
- Horizontal stability system: Diagonal steel wind braces (typically concealed within wall structure). Concrete floor deck and steel structure interlock so that wind forces transmitted through floor to the wind braces.
- Structural floor zone: 3' (915mm) minimum.
- Ceilings: Heights up to 10' (3,048mm).
- Staircase widths: Increased to maximum 3.6m.
- Cladding: As Mark 4 cladding.

CLASP Mk 4B: 1969/72

Mark 4B was similar to Mark 4 but designed for higher education as well as primary and secondary schools. Characteristics include:

- Suspended floor structure: Timber with foam backed rubber covering over hardboard.
- Columns: 4" (102mm) square.
- Ceilings: Preferred floor to ceiling heights are 8' (2,438mm) and 10' (3,048mm) with increased heights in sports facilities etc. 3' x 3' (915 x 915mm) mineral fibre tiles now in an exposed tee system. Similar size Asbestolux panels

Appendix A

also used. 1' x 1' (305 x 305mm) mineral fibre tiles in a concealed system available.

- Cladding: As Mark 4, GRP floor/roof filler panel also available.
- Partitions: Stevetite partitioning used extensively (plastic-faced, steel sheet with plasterboard backing).

CLASP Mk 5: 1972/84

Mark 5 brought the change to metric. Characteristics include:

- Module: Now 100mm with a structural grid of 900mm x 900mm and a planning grid of 300mm x 300mm.
- Cladding: Generally concrete with white, red, grey, brown or green aggregate finish. Also brick cladding trialled in 1972, slate trialled in 1973.
- Roofs: Pitched and hipped roofs from 1976/77.

CLASP Mk6: 1980

The structural grid was increased to 1800mm x 1800mm.

CLASP Mk 6B: 2005

Exposed steel, aluminium finishes and curved roofs.

References and further information

- Building Bulletin 19: The Story of CLASP, Ministry of Education, June 1961
- Building Bulletin 45: CLASP/JDP: The development of a building system for higher education. Department of Education and Science, 1970
- [Designing Buildings: CLASP](#)
- Industrialised Building: CLASP. Diamant R M E.
- Identification Guide. The CLASP Development Group

Appendix B: Guide to common construction materials in school buildings

Introduction

The following pages summarise some of the common issues that occur in construction materials which are commonly used in the education estate. For each issue there is a short summary of the common signs of deterioration and actions that should be taken in the short-term.

In all cases, further advice should be sought from a suitably qualified and experienced building professional, for example a chartered engineer, architect or chartered building surveyor.

Timber

Key maintenance issue

Overloading

Common signs of deterioration

- excessive deflection of timber floor or roof structure
- cracking or splitting of timber floor or roof structure

Description

Timber structures are lightweight and may not have been designed for storage of heavy materials (e.g., paper, furniture etc).

Short-term action

Ensure that areas where heavy objects are being stored have been designed for the weight of the materials concerned. When planning modifications (e.g., building services replacement) ensure that additional weight on the structure has been allowed for. In particular, check for damage at connections between timber elements.

Key maintenance issue

Wet or dry rot (fungal deterioration)

Common signs of deterioration

- staining or softness in timber elements
- splitting or bulging of timber elements
- distortion of timber elements

Description

Wet and dry rot can reduce the load carrying capacity of timber elements. Timber should generally be kept at a moisture content of less than 20%.

Short-term action

For localised damage use commonly available wood fillers to repair damage. Ensure that all damaged timber is removed prior to filling and follow manufacturer's instructions. The cause of the moisture ingress should also be investigated, and roof/wall coverings repaired as necessary. All damp areas should be ventilated so they dry out.

Further advice

Timber specialists can survey timber elements to confirm moisture content. When damage is extensive, consult a suitably qualified and experienced chartered engineer who will be able to develop appropriate remedial solutions.

Appendix B

Key maintenance issue

Mechanical damage

Common signs of deterioration

- notching or drilling of timber, particularly near supports

Description

Holes formed in timber elements, particularly near supports, to allow the installation of electrical or heating services etc.

Short-term action

For localised damage, strengthen sections using additional timber, screws or steel brackets.

Concrete

Key maintenance issue

Corrosion of steel reinforcement within concrete elements

Common signs of deterioration

- cracking or spalling of concrete (possibly revealing corroded steel reinforcement)
- brown staining to surface of concrete elements

Description

Water or chemical ingress into concrete elements can result in steel reinforcement rusting and reducing the load bearing capacity of elements. The corroded steel will expand and in extreme cases will result in some parts of the concrete element breaking off (term 'spalling').

There are many reasons why water can penetrate into concrete elements and cause corrosion. These include where the constituent materials have reacted with the environment, meaning the concrete no longer protects the reinforcement from moisture, or there being insufficient concrete coverage around the reinforcement (this is particularly common for buildings built before the 1980s). There may also be cases where the concrete was not adequately specified to suit the surrounding environment, for example in coastal areas where the marine environment is more aggressive.

Short-term action

For water staining and very minor hairline cracks between infill masonry walls and concrete structures, identify any water leaks and repair the waterproofing or cladding/pointing locally. Allow to dry-out and monitor regularly where the concrete does not exhibit damage.

Further advice

For minor, localised cracking and/or loss of concrete to secondary elements items such as short span lintels supporting masonry, engage a reputable concrete repair specialist immediately to assess and recommend repairs or other courses of action.

Where damage is more extensive (including cracks wider than 0.5mm width, stepped cracks, random hairline cracking (or 'crazing'), or heavy or unusual loads in the vicinity), a suitably qualified and experienced chartered engineer should be consulted who will be able to advise on the cause of the corrosion. They may specify tests by materials' specialists to confirm their initial findings.

Steelwork

Key maintenance issue

Steel corrosion (rusting)

Common signs of deterioration

- rust staining to internal and external finishes
- damage to external or internal finishes near structural elements
- “bubbly” appearance to steelwork elements, including flaking of paint on steelwork

Description

Steelwork is prone to corrosion when it is in contact with water and high humidity. Water and air react with steel to form iron oxide (rust). The corrosion process is expansive and corroded steelwork can expand by 5 to 10 times compared with the volume of structural steel before corrosion. As a result, the corrosion may cause more damage to surrounding elements as it expands than to the structural steelwork itself. Areas such as plant rooms and external facades are therefore particularly vulnerable.

Short-term action

Although non-reversible, the effects of corrosion can be minor for the steelwork if caught early. While unsightly, corrosion of

steelwork is expansive meaning large areas of rust can be caused by minor areas of corrosion. Affected areas should be cleared with a wire brush to remove all loose material and to reveal clean (shiny) steel. Readily available repair and protection products can then be applied to the affected area. The source of water penetration should also be identified and repaired to avoid recurring issues.

Further advice

Engage a suitably qualified and experienced chartered engineer when corrosion is more extensive as an assessment will need to be made on the loss of capacity due to the corrosion process.

Masonry

Key maintenance issue

Damage to pointing

Common signs of deterioration

- erosion/recessing of masonry pointing

Description

Pointing is the finishing of mortar joints between layers (or 'courses') of masonry. The mortar may be softer than the surrounding brick and may be damaged by wind-blown rainwater. Areas of damaged pointing can result in water ingress and in extreme cases can affect the load carrying capacity of the masonry walls.

Short-term action

Affected areas should be removed, joints between brickwork cleaned and a suitable mortar used to repoint the affected areas. It is important that the correct mortar is used for repointing otherwise further damage could be caused.

Further advice

Further advice can be obtained from a brickwork expert or stonemason, chartered building surveyor or architect.

Key maintenance issue

Loss or damage of cavity ties

Common signs of deterioration

- 'bulging' of walls or walls being out-of-plumb (not vertical)
- parallel horizontal cracking at joints
- vertical constant width cracking adjacent to corners

Description

Early masonry ties did not always have sufficient corrosion protection applied and may be prone to rust. This corrosion is expansive and can 'push' the masonry construction upwards. In severe cases, ties completely corrode leading to instability of the masonry construction, noticeable through an outward bulge.

Similar defects are noticeable when there are insufficient ties between the inner and outer leaves.

Short-term action

Monitor cracks regularly to see if they continue to expand. Install crack monitors, also known as 'tell tales' which will confirm whether movement is progressive.

Appendix B

Key maintenance issue

Foundation movement

Common signs of deterioration

- cracking in masonry walls
- distortion of masonry elements

Description

Foundation movement can be caused when the ground moves underneath a building. This is particularly noticeable on masonry buildings as they are brittle (i.e., crack easily) and are a relatively heavy construction type. Common causes of foundation movement are softening of the ground due to nearby cracked drains, ground movement due to water demand from nearby trees, or expansion and contraction of the ground due to hot or cold weather (particularly in clay soils). Foundation movement is common and only needs remedial work if it is progressive (i.e., if movement continues to occur).

Short-term action

Monitor cracks regularly to see if they continue to expand. Install 'tell tales' which will confirm whether movement is progressive.

Key maintenance issue

Chimney and parapet instability

Common signs of deterioration

- chimneys and parapet walls being out-of-plumb (not vertical)

Description

Chimneys and parapets can be damaged by any of the previously mentioned issues. Because they are slender, and often in exposed locations, they can be particularly susceptible to more extreme damage than load bearing masonry walls.

Short-term action

Monitor areas of concern closely, particularly after extreme weather. If movement is continual (progressive), consider creating exclusion areas to avoid damage from falling debris.

Further advice

Seek advice from a chartered building surveyor or structural engineer. In extreme cases, contact your [local council building control team](#) who can advise on dangerous structures.

Woodwool / Strammit

Key maintenance issue

Loss of strength due to water penetration

Common signs of deterioration

- water staining
- sagging of panels
- decomposition of woodwool or Strammit panels

Description

These products were in use in the 1960s onwards and are compressed timber/sawdust (Woodwool) or straw/paper (Strammit) panels generally used to support and insulate concrete above. They were commonly used in roof construction. Due to their composition, they can rapidly lose strength if subject to water ingress leading to sagging and failure.

Short-term action

Where woodwool or Strammit has been affected by water ingress, consideration should be given to risk assess and manage the use of the affected spaces.

Further advice

Consideration should also be given to the replacement of woodwool and Strammit as part of a building's ongoing maintenance and refurbishment plan.

Image credits

Figure 1: Department for Education

Figure 2: Jennifer Singer

Figure 3: Department for Education

Figures 4 & 5: Andrew Rolf

Figure 6: Reds10

Figure 7: Bowmer + Kirkland

Figures 8 to 21 (inclusive): Department for Education



Department
for Education

© Crown copyright 2024

This publication is licensed under the terms of the Open Government Licence v3.0 except where otherwise stated. To view this licence, visit nationalarchives.gov.uk/doc/open-government-licence/version/3.

Where we have identified any third-party copyright information you will need to obtain permission from the copyright holders concerned.

About this publication:

enquiries <https://www.gov.uk/contact-dfe>

download www.gov.uk/government/publications

Follow us on Twitter: [@educationgovuk](https://twitter.com/educationgovuk)

Connect with us on Facebook: facebook.com/educationgovuk