

CD6/1/C

RE: APPEAL BY FCC RECYCLING (UK) LTD PURSUANT TO REGULATION 31 OF THE ENVIRONMENTAL PERMITTING (ENGLAND AND WALES) REGULATIONS 2016 REGARDING DANESHILL SOIL TREATMENT FACILITY AT DANESHILL LANDFILL SITE AND 3C WASTE LIMITED PURSUANT TO REGULATION 31 OF THE ENVIRONMENTAL PERMITTING (ENGLAND AND WALES) REGULATIONS 2016 REGARDING MAW GREEN SOIL TREATMENT FACILITY AT MAW GREEN LANDFILL SITE

APPEAL REFERENCE APP/EPR/636 AND APP/EPR/651 (DANESHILL)

APPEAL REFERENCE APP/EPR/652 (MAW GREEN)

ENVIRONMENTAL PERMIT REFERENCE EPR/NP3538MF (DANESHILL)

ENVIRONMENTAL PERMIT REFERENCE EPR/BS7722ID (MAW GREEN)

APPENDICES FOR PROOF OF EVIDENCE OF SIMON JAMES COLE

Report Reference: 28480-HYD-XX-XX-RP-GE-0007

February 2024

Appendices

- Appendix A Curriculum vitae
- Appendix B US EPA AP-42 calculations
- Appendix C TSI DustTrak DRZ Aerosol Monitor 8534 results for Maw Green STF
- Appendix D Respirable fibres in dust calculations
- Appendix E SoBRA Excel spreadsheet exposure risk calculations
- Appendix F Factual summary of data provided by Provectus or directly acquired by Hydrock
- Appendix G Provectus Work Instructions
- Appendix H Provectus letter on Maw Green and ERQ air monitoring
- Appendix I Screener manufacturer information

Hydrock Consultants Limited (Hydrock) has prepared this report in accordance with the instructions of FCC Recycling (UK) Ltd, under the terms of appointment for Hydrock, for the sole and specific use of the Client and parties commissioned by them to undertake work where reliance is placed on this report. Any third parties who use the information contained herein do so at their own risk. Hydrock shall not be responsible for any use of the report or its contents for any purpose other than that for which it was prepared or for use of the report by any parties not defined in Hydrock's appointment.

Appendix A Curriculum vitae

Dr Simon Cole

TECHNICAL DIRECTOR | PRACTICE AREA LEAD FOR GEOENVIRONMENT

BEng(Hons) PhD CEnv CWEM MCIWEM ASoBRA



Simon is the Technical Lead for Hydrock's Geoenvironment services, part of Hydrock's Geo team. Simon has primary responsibility for the technical delivery of and capability development in services associated with land contamination. Simon specialises in technical review, gap analysis, understanding of issues, problem definition, risk assessment, collaborative development of options, and delivery of guidance and solutions. He is an experienced training provider, speaker, presenter, and researcher. He has developed and published numerous guidance documents, often in collaboration with external organisations.

Key skills

- » Risk Analysis
- » Human health risk assessment
- » Vapour intrusion
- » Ground gas
- » Asbestos in soil
- » Sustainable remediation

Role

Technical advisor

Experience

Simon career has been dominated by the technical development, practice and advocacy of risk assessment methodologies and risk-based management of land contamination. He has been responsible for training and mentoring programmes, and regularly provides training and facilitates workshops, driving innovation in risk-based assessment and land management for internal and external attendees. He frequently presents at industry conferences and has developed and co-written regulator and industry guidance in collaboration with many external stakeholders and partners. Simon has served as national advisor/ technical expert to the EA, the UK Government and the Welsh Government, was the industry nominated representative on Defra's Expert Panel on Part 2A of EPA 1990 and invited member of the Welsh Government's land contamination advisory group. Simon participated in the EC-funded HPA-led Risk ASSETS programme in 2010 and was a BSI Committee member for the CEN standard (CEN/TC 416) BS EN 16736:2015 on Health Risk Assessment of Chemicals.

Simon is a former chair of the Society of Brownfield Risk Assessment (SoBRA), and founded and chaired SoBRA's asbestos in soil working group. Simon is an integral member of the Joint Industry Working Group (JIWG) on Asbestos in Soil. He also chaired NICOLE's European Working Group on asbestos in

soil and was lead author of a NICOLE publication on the approaches to risk-based management of asbestos in Europe that was published in 2021. Collaborating with industry and regulators these groups were focused on innovative best practice – improving the risk management of asbestos in soil – with Simon organising workshops, conference presentations and the publication of papers, risk assessment tools and reports on the topic since 2009. In addition to being a lead author of SoBRA's guidance on asbestos in soil, Simon was an editorial peer reviewer for SoBRA's guidance on ground gas, on climate change, and on contaminant CSMs. Simon currently sits on the SuRF UK Steering Group and on the Energy Institute's Soil Groundwater and Waste Group, and participates in the Environmental Industries Commission Land Contamination Working Group and the AGS Land Contamination Working Group.

Energy Sector

Sellafield CSM update, 2023

Project Director for the digital update of the hydrogeological and contaminant conceptual site model for this 265 ha site using data collected over the previous decade.

Chlorinated Solvent GW plume characterisation, - 2022

Technical advisor for the characterisation, risk assessment and remedial options appraisal of chlorinated solvent contamination

in superficial deposits and fractured bedrock.

Nuclear Industry Briefing Notes - 2022-2023

Lead author for land quality management emerging issue quarterly briefing notes to the nuclear industry land quality teams

Strategic guidance to the nuclear sector, 2020-2021

Project Director for two separate projects looking at strategies for managing emerging contaminants, and land contamination aspects related to site end state planning. Project Director for a separate project benchmarking current UK and international asbestos disposal and treatment capacities and capabilities to provide a baseline for future innovation evaluation.

1/2-day training course on waste and materials management, 2018

Design and delivery of a ½ day training workshop on waste management for site care and maintenance programmes

Site Decommissioning Programme 2017-2021

Technical advisor on risk assessment and waste characterisation to project team assisting in the management of environmental liabilities associated with the decommissioning of the UK's first phase of nuclear power stations.

Workshop on management of asbestos in soil, 2014

Development and presentation of a one-day workshop for a client on the 2014 CIRIA C733 guidance and development of a revised management plan for the site operation.

Data Review and Management Strategy, 2017

Review of data pertaining to asbestos containing fill material and implications for the management of the demolition of a turbine hall and subsequent care and maintenance

Peer Review of Asbestos Soil Remediation Strategy and Implementation, 2015

Review of remediation activities being undertaken to facilitate the segregation and re-use of asbestos-contaminated soil as part of the earthworks for a nuclear new-build.

Nuclear New-Build, North Wales, 2016

Design of an investigation strategy to support the design, implementation and management of the earthworks required for the new power station

Government Sector

PFAS Technical Advisor, 2023

Technical advisor to Natural Resources Wales for a former manufacturing site extensively contaminated with PFAS.

Part 2A investigation into outfall from major urban building fire, 2019 and 2021

Technical Director for Stage 1 and Stage 2 of the Part 2A assessment for the UK Government's multi-agency partnership for Grenfell Tower. Part 2A compliant risk assessment for fire effluents in soil including asbestos in publicly accessible areas within 1km radius of the tower, culminating in reports accepted by the UK Government's Science Advisory Group and the Secretary of State and published on gov.uk.

Landfill Ground Gas DQRA, England, 2017

Detailed ground gas risk assessment under Part 2A for residential houses neighbouring a former landfill for the Environment Agency.

Part 2A investigations for multiple potential Special Sites, 2017-2018

Technical advisor to the AECOM project team for the assessment under Part 2A of ten potential Special Sites, including former industrial facilities and closed landfill sites, for the Environment Agency.

Part 2A Risk Ranking of Closed Landfills in England, 2018

Technical advisor on the development and implementation of a bespoke qualitative risk ranking portfolio assessment tool incorporating digital environmental data and GIS to identify high risk sites requiring further assessment

Expert Witness, 2015

Public Inquiry for a Part 2A remediation notice appeal. Expert witness on behalf of the Local Authority on human health risk relating to an appeal against a determination for residential houses constructed on a former gasworks.

2-day training courses on human health risk assessment, 2014-2015

Project Director, course designer and trainer for two different 2-day courses delivered to the Scottish Environmental Protection Agency in 2015 as a follow up to a 2-day course designed and run in 2014.

Brofiscin Quarry, South Wales, 2009-2014

Technical advisor to Environment Agency Wales on human health issues relating to the remediation of the quarry under Part 2A of EPA 1990, specifically vapour release from the quarry waste and the potential for vapour intrusion into neighbouring homes.

National advisor to the Environment Agency, 2003-2011

National technical advisor providing technical advice to Capital Projects on over 100 Part 2A sites, training to Environment Agency and Local Authority technical officers, and re-drafting of Soil Guideline Value reports for publication.

Asbestos DQRAs for Local Authorities, England, 2014-2019

A Part 2A risk assessment for a local nature reserve bordering a new residential development.

A Part 2A risk methodology developed for asbestos cement fragments in residential gardens for a Local Authority.

A Part 2A compliant risk assessment for a residential area built on a former dye works where asbestos was a key contaminant.

A Part 2A compliant quantitative exposure and risk estimation assessment for a housing estate built on former industrial land in the 1980s where asbestos was the key contaminant.

The design of an activity-based sampling methodology for asbestos contaminated soil in residential gardens to support LA risk-based decision making.

Project Director for a phase 3 site investigation and DQRA for

asbestos in soil contamination at a 115 property housing estate.

Development of European Standard, 2014

Participation in the EC-funded HPA-led Risk ASSETS programme in 2010, and a BSI Committee member for the CEN standard (CEN/TC 416) EN 16736 on Health Risk Assessment of Chemicals.

Defra Research Project SP1014, 2016

Proposer and member of the project steering group for this research project looking at the background soil concentration of asbestos across the UK as a result of historic diffuse anthropogenic atmospheric release. Project involved a university team taking samples across the UK on a 50km grid. Project report published on Defra scientific research website.

Former Railway depot and Chemical Works, 2017

Review of 20 years' worth of reports on the site and advice to the Local Authority on the Part 2A status of identified contaminant linkages

National Regulatory Guidance, 2009

Re-drafting of national guidance publications on UK Soil Guideline Values for the Environment Agency

Industrial Sector

DNAPL investigation, Scotland, 2012

Project Director for investigation of residual chlorinated hydrocarbon contamination in fractured bedrock, including worked coal seams beneath a former pharmaceutical site. Work also included vapour intrusion modelling for existing buildings

and indoor vapour survey to support site divestment.

DNAPL Remediation, England, 2012

Technical advisor on vapour emission modelling and control for site remediation, including soil excavation and thermal desorption of chlorinated solvent contamination.

Paint Factory Remediation, South Wales, 2012-2017

Project Director for detailed investigation, risk assessment and remediation of a 14ha site for residential redevelopment, including delineation, excavation and biotreatment of soils contaminated with paint solvents. Detailed vapour release modelling undertaken as part of condition for remediation consent.

White Phosphorus, England, 2013

Ecological and human health risk assessment for white phosphorus sediment contamination in an urban canal network.

Global Regulatory Review for PFAS Water Quality Criteria, 2021

Lead author for EU and UK for a global review of PFAS related water quality values, regulatory positions and guidance.

3-day training course on risk-based corrective action at petroleum release sites, 2018

Co-developer and co-presenter for a 3-day bespoke course for client employees and national regulators

Global Regulatory Review for Emerging Contaminants, 2014

Designer and project manager for a global review of regulation and guidance on emerging contaminants associated with the Stockholm Convention. Project team included staff from twelve different countries.

Oil Refinery, South Wales, 2009

Human health, ecological and controlled waters DQRA.

Oil Refinery, South Wales, 2004

Human health risk assessment and development of a bespoke stochastic remediation cost model for the redevelopment of a former oil refinery into an urban village.

European Retail Portfolio, 2010-2019

European technical and advocacy focal point for environmental site assessment programme for major oil company

UK Retail Portfolio, 2010

Technical peer review of investigation, risk assessment and remedial design programme for a series of UK sites for a major oil company

Commercial Sector

Due Diligence for a former industrial area, Cardiff, 2023

Technical advisor on land contamination risks as part of a multi-disciplinary due diligence exercise for the potential acquisition of a site in central Cardiff.

Remediation Due Diligence for a large former manufacturing site, England, 2023

Project Director for a detailed desk-based appraisal of potential remediation liabilities incorporating Monte Carlo remediation extent and cost estimation modelling

Sustainable remediation assessment, strategic development site, England, 2020

Sustainable remediation assessment and strategy for asbestos-contaminated land forming part of a large development scheme.

Redevelopment of military training facility, 2017

Independent peer review of remediation strategy for dealing with asbestos contaminated ground for an 18ha construction project. Project evolved into the review of the organisation's risk evaluation procedure for asbestos across its estate, and development of new and revised policies and procedures to better capture the potential project risk associated with asbestos in soil

Redevelopment of a former vehicle manufacturing plant, England, 2014-2016

Technical advisor on the management of asbestos contamination of ground and crushed building demolition waste for the redevelopment of a 90 acre site.

Tipner Regeneration Project, Portsmouth, 2011-2014

Technical advisor to Portsmouth City Council on land contamination issues relating to the planning process for the remediation of the various land parcels that make up the area for this flagship regeneration project.

Redevelopment of a former commercial dry cleaning facility, England, 2012

Detailed vapour emission modelling as part of the remediation feasibility, design and implementation process.

Independent review of asbestos in soil remediation strategy, 2016

Review of a proposed remediation strategy for a residential development site

Independent review of major public sector construction project, England, 2017

Review of asbestos remediation strategy and implementation, project risk and wider programmatic implications.

Independent review of redevelopment of London former gas works, 2017

Review and advice to remediation contractor on significance and implication of identified asbestos ground contamination

Redevelopment of a former gas works in London, 2020

Advice on required licencing and control and monitoring measures required for proposed remediation scheme.

Redevelopment of agricultural land for strategic housing development in Southern England, 2020

Review and advice on remediation strategy and implementation for former farmland littered with asbestos containing waste.

Expert Advisor for Soil Treatment Facility EPR permit appeal site, England, 2023

Expert advisor on airborne asbestos fibre risk assessment for an appeal against the refusal of an asbestos in soil processing application for a soil treatment facility in England, 2023.

Additional professional experience:

Technical Lead for update of CL:AIRE SuRF UK Tier 1 spreadsheet, 2021
<https://www.claire.co.uk/home/news/1476-surf-uk-tier-1-assessment-tool>

Contributor to the SAGTA/CL:AIRE C4SL second phase project, acting as a Tier 2 toxicologist, 2018

Contributor to the EIC/AGS/CL:AIRE Soil Generic Assessment Criteria for Human Health Risk Assessment report published by CL:AIRE, December 2009, including the SR2-compliant phys-chem and toxicological reviews and peer reviews for substances.

Selected Publications and Presentations

Co-author of Asbestos in Soil Human Health Risk Assessment (AiSHHRA) Toolbox, SoBRA, December 2021

Lead author of "Asbestos in Soil – a pan European Perspective", NICOLE, June 2021
<https://nicole.org/uploadedfiles/20210617%20Asbestos%20In%20Soil%20booklet%20NICOLE%20.pdf>

Co-author of Variability in UK Laboratory Methods for the Identification and Quantification of Asbestos in Soil, SoBRA, February 2021

Co-author of "Guidelines for Airborne Concentrations of Asbestos Fibres in Ambient Air: Implications for Quantitative Risk Assessment", Discussion Paper, SoBRA, January 2021
 Peer reviewer for "Management of Asbestos in Soils – An All-Ireland Guidance Document", Ireland Brownfield Network, April 2020

Co-author of The Distribution of Asbestos in Soil – what can the data mining of sample results held by UK laboratories tell us?, Discussion Paper, SoBRA, March 2020

Asbestos in soil: A European Perspective. NICOLA annual conference, Cape Town, South Africa, October 2019

Asbestos in soil: A European Perspective. Waste Khoro: Land contamination and Asbestos, Kimberley, South Africa, September 2019

Asbestos – perceptions and reality, Influence & implications for risk management, Geological Society of London, Engineering Geology of Contaminated Land, June 2019

"Developing Practitioner guidance for a smarter future", Asbestos: The Truth, asbestos management conference, Manchester, Nov. 2017

"Benefits of professional qualifications and accreditation: a view from industry", The Geological Society of London, Janet Watson Conference, Nov. 2017

"Asbestos: Practical strategies for identifying, risk assessing and dealing with asbestos during GI" presented at the Brownfield Briefing conference on Innovative Site Investigation and Risk Assessment, London, May 2016

"Vapour intrusion risk assessment under Part 2A", presented at the annual SoBRA conference at the RSC, London, Dec 2015

Joint Industry Working Group for Asbestos in Soil and Construction & Demolition Materials (JIWG) decision support tools, lead developer, January 2016

BSI Committee member for the CEN standard (CEN/TC 416) BS EN 16736:2015 on Health Risk Assessment of Chemicals

"Risk-- Based Assessment and Management of Asbestos-in-Soil (ASBINS) in Australia and update on SoBRA's work in UK", presented at the NICOLE Unconventional Contaminants conference, Manchester, June 2015

Author of various discussion papers and protocols on asbestos in soil published by SoBRA, (available via sobra.org.uk), April 2015

Contributor to "Risks to Human Health from Asbestos in Soil Workshop Report", SoBRA, 2015

"Dealing with Contaminated Land", November and December 2014, presented at the BOHS/HSE asbestos roadshows, Glasgow, London and Manchester.

"Asbestos in Soil: Recent Developments in Guidance", May 2014, presented at the annual IBN conference, Cork, Ireland

"Approaches to exposure assessment", June 2013, presented at the annual SoBRA summer workshop on Risks to Human Health from Asbestos in Soil, Birmingham.

"Using Soil Guideline Values", Science Report SC050021/SGV Introduction, Environment Agency, March 2009

Drafts of updated SGV reports for chromium and lead (not published), Environment Agency 2009

Appendix B US EPA AP-42 calculations

AP-42 calculations for all STF operations with a soil/material moisture content set at 10%

Approaches to dust emission estimation detailed in US EPA AP-42

US EPA Air Emission Factors and Quantification. AP-42: Compilation of Air Emission Factors.

These calculations are all reproduced from the guidance contained here <https://www.epa.gov/air-emissions-factors-and-quantification/ap-42-Compilation-air-emissions-factors>.

AP-42 is the primary source used by the US EPA for information concerning emissions factors, developed and compiled from test data and engineering estimates. The emission factors represent the average of the range of emission rates evaluated.

The overarching equation for emissions is:

$$E = A \times EF \times (1 - ER) / 100$$

- E = emissions
- A = activity rate
- EF = emission factor
- ER = overall emission reduction efficiency (%)

An estimate of the resultant fugitive airborne dust concentration can be calculated using a simple box model:

$$C = E / h \times W \times u$$

- C = airborne dust concentration
- h = height of mixing zone box
- W = width of mixing zone perpendicular to wind direction
- u = mean wind speed through box

Section 13.2 of AP-42 covers fugitive dust sources, estimating dust emissions from the disturbance of granular material, and consequently is the most relevant section of AP-42 for considering emissions from brownfield activities. The two main physical actions involved in this process are the pulverisation and abrasion of surface materials by the application of mechanical force, and the entrainment of dust particles by the action of turbulent air currents.

Heavy Construction Operations (13.2.3)

Section 13.2.3 provides some very broad estimates with regard to dust emissions from construction operations. Essentially, dust emissions are considered proportional to the site size and the level of construction activity taking place.

The following emission factor is included in AP-42 for heavy construction activities:

	Value	Units	
EF (TSP emission factor)	0	kg per ha per month	TSP = total suspended solids (will over-estimate PM10 concentration)
Area in which activity is taking place		ha	Assumes 30 days of continuous activity per month

These emission factors are most applicable to operations with a medium level of activity, moderate silt content and a semi-arid climate, and are likely to result in unrealistically high PM-10 estimates. In practice emissions from construction activities will vary substantially over the duration of the project. As a result, AP-42 recommends that construction activities are broken down into component operations. Recommended emission factors are provided in Table 13.2.3-1 as follows:

Construction Phase	Dust Generating Activities	Recommended Emission Factor
Demolition and clearance	General land clearance	Dozer equation (overburden) in Tables 11.9-1 and 11.9-2
	Loading of material into trucks	Material handling equation (section 13.2.4)
	Truck transport of material	Unpaved road equation (section 13.2.2) or paved road equation (section 13.2.1)
	Truck unloading of material	Material handling equation (section 13.2.4)
Site preparation (earthworks)	Bulldozing	Dozer equation (overburden) in Tables 11.9-1 and 11.9-2
	Scrapers unloading topsoil	Scraper unloading factor in Table 11.9-4
	Scrapers in travel	Scraper (travel mode) equation in Tables 11.9-1 and 11.9-2 (unpaved road emission factor equation in AP-42 Section 13.2.2)
	Scrapers removing topsoil	EF = 5.7kg per vehicle km travelled (VKT)
	Loading excavated material into trucks	Material handling equation (section 13.2.4)
	Truck dumping of fill material, road base, or other materials	Material handling equation (section 13.2.4)
	Compacting	Dozer equation (overburden) in Tables 11.9-1 and 11.9-2
	Grading	Grading equation in Tables 11.9-1 and 11.9-2
General construction	Vehicular traffic	Unpaved road equation (section 13.2.2) or paved road equation (section 13.2.1)
	Portable plants - crushing	Factors for similar material/operations in section 11.19.2
	Portable plants - screening	Factors for similar material/operations in section 11.19.2
	Portable plants - material transfers	Material handling equation (section 13.2.4)

The following section is also likely to be of relevance when considering emissions from brownfield activities:
 13.2.5 - Industrial Wind Erosion

Demolition and clearance

General land clearance (11.9.2)

	Value	Units
EF (for TSP <30µm)	#DIV/o!	kg per hour
EF (for PM10)	#DIV/o!	kg per hour
s (material silt content)		%
M (material moisture content)		%

Loading / unloading material into trucks (13.2.4)

	Value	Units
EF	#DIV/o!	kg per tonne(megagram)
U (mean wind speed)		m/s
M (material moisture content)		%
k (particle size multiplier)		(-)

Transporting of material by truck (13.2.1 and 13.2.2)

<u>Paved road</u>		
	Value	Units
EF	0	g per VKT
k (particle size multiplier)		g/VKT
sL (road surface silt loading)		g/m ²
W (weight of vehicle)		tons

Unpaved road

	Value	Units
EF (industrial sites)	934718481	g/VKT
EF (light vehicles using public roads)	2850381738	g/VKT
k (particle size multiplier)	15	lb/VMT
s (surface material silt content)	100	%
W (mean vehicle weight)	42	tons
M (surface material moisture content)	5	%
S (mean vehicle speed)	10	mph
C (emission factor for exhaust, brake and tyre wear)	0.00047	lb/VMT
a (empirical constant)	0.9	(-)
b (empirical constant)	0.45	(-)
c (empirical constant)		(-)
d (empirical constant)		(-)

Site preparation (earthworks)

Bulldozing (11.9.2)

	Value	Units
EF (for TSP <30µm)	#DIV/o!	kg per hour
EF (for PM10)	#DIV/o!	kg per hour
s (material silt content)		%
M (material moisture content)		%

Justification Additional notes from AP-42 guidance

Particle size	<30 µm	<15 µm	<10 µm	<5 µm	<2.5 µm
k	0.74	0.48	0.35	0.2	0.053

Particle size	PM30	PM15	PM10	PM2.5
k	3.23	0.77	0.62	0.15
Location	Quarry	Sand and gravel processing		Landfill
sL (mean)	8.2	70		7.4

k for PM10
 Worst-case assumption
 Example for a Volvo A25 - 20t payload + 22t net weight
 Assumption that surface material content will be lower than that for processed soil
 Likely maximum speed given scale and layout of STF
 C for PM10
 For PM10
 For PM10

	Industrial roads			Public roads		
	PM2.5	PM10	PM30	PM2.5	PM10	PM30
k	0.15	1.5	4.9	0.18	1.8	6
a	0.9	0.9	0.7	1	1	1
b	0.45	0.45	0.45	-	-	-
c	-	-	-	0.2	0.2	0.3
d	-	-	-	0.5	0.5	0.3

C	0.00036	0.00047	0.00047
---	---------	---------	---------

Justification Additional notes from AP-42 guidance

Scrapers unloading topsoil (11.9.2)

Value	Units
0.02	kg/tonne(megagram)

Scrapers in travel (13.2.2)

Value	Units
#NUM!	g/VKT
	lb/VMT
	%
	tons
	(-)
	(-)

Scrapers removing topsoil (11.9.2 & 13.2.4)

Value	Unit
0.029	kg/tonne(megagram)
5.7	kg/VKT

Loading / unloading material into trucks (13.2.4)

Value	Units
0.000127985	kg per tonne(megagram)
4	m/s
10	%
0.35	(-)

Compacting (11.9.2)

Value	Units
#DIV/0!	kg per hour
#DIV/0!	kg per hour
	%
	%

Grading (11.9.2)

Value	Units
0	kg/VKT
0	kg/VKT
	kph

General Construction

Vehicular traffic (13.2.1 & 13.2.2)

Value	Units
0	g per VKT
	g/VKT
	g/m ²
	tons

Unpaved road

Value	Units
934718481	g/VKT
2850.381738	g/VKT
15	lb/VMT
100	%
42	tons
	%
5	%
10	mph
0.00047	lb/VMT

Annual average wind speed for nearest Met Office climate station, and for the Midlands District is approximately 8 knots (4m/s)
<https://www.metoffice.gov.uk/research/climate/maps-and-data/uk-climate-averages/gc21p9f>
 Analysis of soil moisture for pre- and post-processed soil at two Provecutx STF suggests lower quartile of 10%
 k for PM10

	PM2.5	PM10	PM30
k	0.15	1.5	4.9
a	0.9	0.9	0.7
b	0.45	0.45	0.45

Particle size	<30 µm	<15 µm	<10 µm	<5 µm	<2.5 µm
k	0.74	0.48	0.35	0.2	0.053

Justification

Additional notes from AP-42 guidance

Particle size	PM30	PM15	PM10	PM2.5
k	3.23	0.77	0.62	0.15

Location	Quarry	Sand and gravel processing	Landfill
sL (mean)	8.2	70	7.4

k for PM10
 Worst-case assumption
 Example for a Volvo A25 - 20t payload + 22t net weight
 Assumption that surface material content will be lower than that for processed soil
 Likely maximum speed given scale and layout of STF
 C for PM10

	Industrial roads			Public roads		
	PM2.5	PM10	PM30	PM2.5	PM10	PM30
k	0.15	1.5	4.9	0.18	1.8	6
a	0.9	0.9	0.7	1	1	1
b	0.45	0.45	0.45	-	-	-
c	-	-	-	0.2	0.2	0.3
d	-	-	-	0.5	0.5	0.3

a (empirical constant)
 b (empirical constant)
 c (empirical constant)
 d (empirical constant)

0.9	(-)
0.45	(-)
	(-)
	(-)

For PM10
 For PM10

C	0.00036	0.00047	0.00047
---	---------	---------	---------

Portable plants - crushing (11.19.2)

Value	Units
0.0027	kg/tonne(megagram)
0.0006	kg/tonne(megagram)
0.0012	kg/tonne(megagram)
0.00027	kg/tonne(megagram)
	kg/tonne(megagram)

Portable plants - screening (11.19.2)

Value	Units
0.0125	kg/tonne(megagram)
0.0011	kg/tonne(megagram)
0.0043	kg/tonne(megagram)
0.00037	kg/tonne(megagram)
0.00037	kg/tonne(megagram)

EF for PM10 for controlled operations

Portable plants - conveyor transfer (11.19.2)

0.0015	kg/tonne(megagram)
0.00007	kg/tonne(megagram)
0.00055	kg/tonne(megagram)
0.000023	kg/tonne(megagram)
0.000023	kg/tonne(megagram)

EF for PM10 for controlled operations

Portable plants - material transfers (13.4.2)

0.000127985	kg per tonne(megagram)
4	m/s
10	%
0.35	(-)

Annual average wind speed for nearest Met Office climate station, and for the Midlands District is approximately 8 knots (4m/s)
 Analysis of soil moisture for pre- and post-processed soil at two Provecus STF suggests lower quartile of 10%
 k for PM10

Particle size	<30 µm	<15 µm	<10 µm	<5 µm	<2.5 µm
k	0.74	0.48	0.35	0.2	0.053

Aggregate Handling and Storage Piles (13.2.4)

Though drafted to consider outdoor storage piles of mineral aggregates, Section 13.2.4 of AP-42 may be utilised to model dust emissions from soil stockpiles. However, AP-42 assumes that stockpiles are left uncovered, which is unlikely to be the case with stockpiles of ACS on brownfield sites.

Dust emissions are modelled at various points:

- Movement of trucks and material loading onto stockpiles;
- Wind disturbance of piles;
- Loadout from the piles; and
- Movement of trucks and loading equipment within the storage pile area (i.e. site movement of plant).

The potential for dust emissions are at a peak when material is added to storage piles, as fines are easily disaggregated and released to the atmosphere, either through transfer from plant or due to high winds. The potential for emissions is significantly reduced as the stockpile weathers, due to aggregation and cementation of fines. Rainfall can soak the pile, and the drying process is slow.

AP-42 contains the following empirical expression, to estimate the quantity of particulate emissions generated per tonne of material stockpiled:

Value	Units
0.000127985	kg per tonne of material moved
0.35	(-)
4	m/s
10	%

Justification	Additional notes from AP-42 guidance
k for PM10	Particle size
Annual average wind speed for nearest Met Office climate station, and for the Midlands District is approximately 8 knots (4m/s)	<30 µm
Analysis of soil moisture for pre- and post-processed soil at two Provecus STF suggests lower quartile of 10%	<15 µm
	<10 µm
	<5 µm
	<2.5 µm

k	0.74	0.48	0.35	0.2	0.053
---	------	------	------	-----	-------

Industrial Wind Erosion (13.2.5)

	Value	Units
EF	0.591121	g/m ³ per day
k (particle size multiplier)	0.5	(-)
P (erosion potential)	1182242	g/m ³
u' (frictional velocity)	0.583	m/s
ut (threshold friction velocity)	0.54	m/s
u (maximum wind speed at a height of 10m)	11	m/s

k for PM10

-ut for coal dust on concrete pad
Wind speed at which u' > ut (equivalent to a 'strong breeze')

Particle size	30 µm	<15 µm	<10 µm	<2.5 µm
	1	0.6	0.5	0.075
k				
Material	Threshold Friction Velocity (m/s)	Roughness Height (cm)	Threshold Wind Velocity A (10 m (m/s))	
			$z_0 = Act$	$z_0 = 0.8 cm$
Overburden ^a	1.02	0.3	21	19
Scoria (roadbed material) ^a	1.33	0.3	27	25
Gravel coal (surrounding coal pile) ^a	0.55	0.01	16	10
Uncovered coal pile ^a	1.12	0.3	23	21
Scraper tracks on coal pile ^{a,b}	0.62	0.06	15	12
Fine coal dust on concrete pad ^c	0.54	0.2	11	10

All information taken from AP-42: *Compilation of Air Pollutant Emission Factors, 5th edition, Volume 1, Chapter 13: Miscellaneous Sources, 1995-2011*
<https://www.epa.gov/air-emissions-factors-and-quantification/ap-42-fifth-edition-volume-i-chapter-13-miscellaneous-0>

Estimated airborne dust concentrations based on AP-42 EFs

	Value	Units
h (height of mixing zone box)	2	m
W (width of mixing zone box perpendicular to wind direction)	50	m
u (mean wind speed through box)	4	m/s

Supporting information
Selected to reasonably reflect air mass sampled by air monitoring instrumentation
Reasonable reflection of operational scale
Annual average wind speed for nearest Met Office climate station, and for the Midlands District is approximately 8 knots (4m/s)

Generic heavy construction activity emissions

EF (TSP emission rate)	0.00E+00	kg per month
A (activity rate)		number of days of activity per month
C (dust concentration)	0.00E+00	mg/m ³

[Assumes 10hrs activity per day]

Demolition and clearance

General land clearance (11.9.2)

EF (calculated PM10 emission rate)	#DIV/0!	kg per hour
A (activity rate)		hour
C (dust concentration)	#DIV/0!	mg/m ³

[Set at one unit as concentration is independent of time]

Loading / unloading material into trucks (13.2.4)

EF (calculated emission rate)	#DIV/0!	kg per tonne
A (activity rate)		tonnes of material moved per hour
C (dust concentration)	#DIV/0!	mg/m ³

Transporting of material by truck (paved road) (13.2.1)

EF (calculated emission rate)	0.00E+00	g per VKT
A (activity rate)		VKT per hour
C (dust concentration)	0.00E+00	mg/m ³

Transporting of material by truck (unpaved road) (13.2.2)

EF (calculated emission rate)	1.22E+04	g per VKT
A (activity rate)		VKT per hour
C (dust concentration)	0.00E+00	mg/m ³

Site preparation (earthworks)

Bulldozing (11.9.2)

EF (calculated PM10 emission rate)	#DIV/0!	kg per hour
A (activity rate)		hour
C (dust concentration)	#DIV/0!	mg/m ³

[Set at one unit as concentration is independent of time]

Scrapers unloading topsoil (11.9.2)

EF (calculated emission rate)	2.00E-02	kg per tonne
A (activity rate)		tonnes of material moved per hour
C (dust concentration)	0.00E+00	mg/m ³

Scrapers in travel (13.2.2)

EF (calculated emission rate)	#NUM!	g/VKT
A (activity rate)		VKT per hour
C (dust concentration)	#NUM!	mg/m ³

Scrapers removing topsoil (11.9.2 & 13.2.4)

EF (calculated emission rate)	2.90E-02	kg per tonne
A (activity rate)		tonnes of material moved per hour
C (dust concentration)	0.00E+00	mg/m ³
Alternative EF	5.70E+00	kg per VKT
Alternative A		VKT per hour
Alternative C	0.00E+00	mg/m ³

Loading / unloading material into trucks (13.2.4)

EF (calculated emission rate)	1.28E-04	kg per tonne	Assumption of 500 tonne process rate per day (8 hours) based on Provectus information on typical STF operations
A (activity rate)	62.5	tonnes of material moved per hour	
C (dust concentration)	5.55E-03	mg/m ³	

Compacting (11.9.2)

EF (calculated PM10 emission rate)	#DIV/0!	kg per hour	[Set at one unit as concentration is independent of time]
A (activity rate)		hour	
C (dust concentration)	#DIV/0!	mg/m ³	

Grading (11.9.2)

EF (calculated PM10 emission rate)	0.00E+00	kg per VKT
A (activity rate)		VKT per hour
C (dust concentration)	0.00E+00	mg/m ³

General Construction

Vehicular traffic (paved road) (13.2.1)

EF (calculated emission rate)	0.00E+00	g per VKT
A (activity rate)		VKT per hour
C (dust concentration)	0.00E+00	mg/m ³

Vehicular traffic (unpaved road) (13.2.2)

EF (calculated emission rate)	1.22E+04	g per VKT	Assumption that vehicle movements limited to approximately 100 m per hour (e.g. transfer from process stockpile to storage stockpile)
A (activity rate)	0.1	VKT per hour	
C (dust concentration)	8.47E-01	mg/m ³	

Portable plants - crushing (11.19.2)

EF (calculated emission rate)	0.00E+00	kg per tonne
A (activity rate)		tonnes of material moved per hour
C (dust concentration)	0.00E+00	mg/m ³

Portable plants - screening (11.19.2)

EF (calculated emission rate)	3.70E-04	kg per tonne	Assumption of 500 tonne process rate per day (8 hours) based on Provecclus information on typical STF operations
A (activity rate)	62.5	tonnes of material moved per hour	
C (dust concentration)	1.61E-02	mg/m ³	

Portable plants - conveyor transfer (11.19.2)

EF (calculated emission rate)	2.30E-05	kg per tonne	Assumption of 150 tonne process rate per day (8 hours) based on Provecclus information on typical STF operations for picking station
A (activity rate)	18.75	tonnes of material moved per hour	
C (dust concentration)	2.99E-04	mg/m ³	

Portable plants - material transfers (13.4.2)

EF (calculated emission rate)	1.28E-04	kg per tonne	Assumption of 500 tonne process rate per day (8 hours) based on Provecclus information on typical STF operations
A (activity rate)	62.5	tonnes of material moved per hour	
C (dust concentration)	5.55E-03	mg/m ³	

Aggregate Handling and Storage Piles (13.2.4)

EF (calculated emission rate)	1.28E-04	kg per tonne of material moved
A (activity rate)	62.5	tonnes of material handled per hour
C (dust concentration)	5.55E-03	mg/m ³

Industrial Wind Erosion (13.2.5)

EF (calculated emission rate)	5.91E-01	g per m ² surface area per day	Note: this is only relevant if wind speed during day exceeds threshold wind speed Approximate estimate of potential STF exposed slab area for proposed scale of STF (50% of a 50m x 50m area) Assumes a daily disturbance duration of 8 hours
A (activity rate)	1250	ground surface area of interest (m ²)	
C (dust concentration)	6.41E-02	mg/m ³	

AP-42 calculations for all STF operations with a soil/material moisture content set at 1%

Approaches to dust emission estimation detailed in US EPA AP-42

US EPA Air Emission Factors and Quantification. AP-42: Compilation of Air Emission Factors.

These calculations are all reproduced from the guidance contained here <https://www.epa.gov/air-emissions-factors-and-quantification/ap-42-compilation-air-emissions-factors>.

AP-42 is the primary source used by the US EPA for information concerning emissions factors, developed and compiled from test data and engineering estimates. The emission factors represent the average of the range of emission rates evaluated.

The overarching equation for emissions is:

$$E = A \times EF \times (1 - ER) / 100$$

E = emissions

A = activity rate

EF = emission factor

ER = overall emission reduction efficiency (%)

An estimate of the resultant fugitive airborne dust concentration can be calculated using a simple box model:

$$C = E / h \times W \times u$$

C = airborne dust concentration

h = height of mixing zone box

W = width of mixing zone perpendicular to wind direction

u = mean wind speed through box

Section 13.2 of AP-42 covers fugitive dust sources, estimating dust emissions from the disturbance of granular material, and consequently is the most relevant section of AP-42 for considering emissions from brownfield activities. The two main physical actions involved in this process are the pulverisation and abrasion of surface materials by the application of mechanical force, and the entrainment of dust particles by the action of turbulent air currents.

Heavy Construction Operations (13.2.3)

Section 13.2.3 provides some very broad estimates with regard to dust emissions from construction operations. Essentially, dust emissions are considered proportional to the site size and the level of construction activity taking place.

The following emission factor is included in AP-42 for heavy construction activities:

	Value	Units	
EF (TSP emission factor)	0	kg per ha per month	TSP = total suspended solids (will over-estimate PM10 concentration)
Area in which activity is taking place		ha	Assumes 30 days of continuous activity per month

These emission factors are most applicable to operations with a medium level of activity, moderate silt content and a semi-arid climate, and are likely to result in unrealistically high PM-10 estimates.

In practice emissions from construction activities will vary substantially over the duration of the project. As a result, AP-42 recommends that construction activities are broken down into component operations. Recommended emission factors are provided in Table 13.2.3-1 as follows:

Construction Phase	Dust Generating Activities	Recommended Emission Factor
Demolition and clearance	General land clearance	Dozer equation (overburden) in Tables 11.9-1 and 11.9-2
	Loading of material into trucks	Material handling equation (section 13.2.4)
	Truck transport of material	Unpaved road equation (section 13.2.2) or paved road equation (section 13.2.1)
	Truck unloading of material	Material handling equation (section 13.2.4)
Site preparation (earthworks)	Bulldozing	Dozer equation (overburden) in Tables 11.9-1 and 11.9-2
	Scrapers unloading topsoil	Scraper unloading factor in Table 11.9-4
	Scrapers in travel	Scraper (travel mode) equation in Tables 11.9-1 and 11.9-2 (unpaved road emission factor equation in AP-42 Section 13.2.2)
	Scrapers removing topsoil	EF = 5.7kg per vehicle km travelled (VKT)
	Loading excavated material into trucks	Material handling equation (section 13.2.4)
	Truck dumping of fill material, road base, or other materials	Material handling equation (section 13.2.4)
	Compacting	Dozer equation (overburden) in Tables 11.9-1 and 11.9-2
General construction	Grading	Grading equation in Tables 11.9-1 and 11.9-2
	Vehicular traffic	Unpaved road equation (section 13.2.2) or paved road equation (section 13.2.1)
	Portable plants - crushing	Factors for similar material/operations in section 11.19.2
	Portable plants - screening	Factors for similar material/operations in section 11.19.2
	Portable plants - material transfers	Material handling equation (section 13.2.4)

The following section is also likely to be of relevance when considering emissions from brownfield activities:
 13.2.5 - Industrial Wind Erosion

Demolition and clearance

General land clearance (11.9.2)

	Value	Units
EF (for TSP <30µm)	#DIV/o!	kg per hour
EF (for PM10)	#DIV/o!	kg per hour
s (material silt content)		%
M (material moisture content)		%

Loading / unloading material into trucks (13.2.4)

	Value	Units
EF	#DIV/o!	kg per tonne(megagram)
U (mean wind speed)		m/s
M (material moisture content)		%
k (particle size multiplier)		(-)

Transporting of material by truck (13.2.1 and 13.2.2)

<u>Paved road</u>		
	Value	Units
EF	0	g per VKT
k (particle size multiplier)		g/VKT
sL (road surface silt loading)		g/m ²
W (weight of vehicle)		tons

Unpaved road

	Value	Units
EF (industrial sites)	934718481	g/VKT
EF (light vehicles using public roads)	2850381738	g/VKT
k (particle size multiplier)	15	lb/VMT
s (surface material silt content)	100	%
W (mean vehicle weight)	42	tons
M (surface material moisture content)	5	%
S (mean vehicle speed)	10	mph
C (emission factor for exhaust, brake and tyre wear)	0.00047	lb/VMT
a (empirical constant)	0.9	(-)
b (empirical constant)	0.45	(-)
c (empirical constant)		(-)
d (empirical constant)		(-)

Site preparation (earthworks)

Bulldozing (11.9.2)

	Value	Units
EF (for TSP <30µm)	#DIV/o!	kg per hour
EF (for PM10)	#DIV/o!	kg per hour
s (material silt content)		%
M (material moisture content)		%

Justification Additional notes from AP-42 guidance

Particle size	<30 µm	<15 µm	<10 µm	<5 µm	<2.5 µm
k	0.74	0.48	0.35	0.2	0.053

Particle size	PM30	PM15	PM10	PM2.5
k	3.23	0.77	0.62	0.15
Location	Quarry	Sand and gravel processing		Landfill
sL (mean)	8.2	70		7.4

k for PM10
 Worst-case assumption
 Example for a Volvo A25 - 20t payload + 22t net weight
 Assumption that surface material content will be lower than that for processed soil
 Likely maximum speed given scale and layout of STF
 C for PM10
 For PM10
 For PM10

	Industrial roads			Public roads		
	PM2.5	PM10	PM30	PM2.5	PM10	PM30
k	0.15	1.5	4.9	0.18	1.8	6
a	0.9	0.9	0.7	1	1	1
b	0.45	0.45	0.45	-	-	-
c	-	-	-	0.2	0.2	0.3
d	-	-	-	0.5	0.5	0.3

C	0.00036	0.00047	0.00047
---	---------	---------	---------

Justification Additional notes from AP-42 guidance

Scrapers unloading topsoil (11.9.2)

Value	Units
0.02	kg/tonne(megagram)

Scrapers in travel (13.2.2)

Value	Units
#NUM!	g/VKT
	lb/VMT
	%
	tons
	(-)
	(-)

Scrapers removing topsoil (11.9.2 & 13.2.4)

Value	Unit
0.029	kg/tonne(megagram)
5.7	kg/VKT

Loading / unloading material into trucks (13.2.4)

Value	Units
0.002214834	kg per tonne(megagram)
4	m/s
1	%
0.35	(-)

Compacting (11.9.2)

Value	Units
#DIV/0!	kg per hour
#DIV/0!	kg per hour
	%
	%

Grading (11.9.2)

Value	Units
0	kg/VKT
0	kg/VKT
	kph

General Construction

Vehicular traffic (13.2.1 & 13.2.2)

Paved road

Value	Units
0	g per VKT
	g/VKT
	g/m²
	tons

Unpaved road

Value	Units
934718481	g/VKT
2850.381738	g/VKT
15	lb/VMT
100	%
42	tons
1	%
10	mph
0.00047	lb/VMT

Annual average wind speed for nearest Met Office climate station, and for the Midlands District is approximately 8 knots (4m/s)
<https://www.metoffice.gov.uk/research/climate/maps-and-data/uk-climate-averages/gcx21pgf>

Analysis of soil moisture for pre- and post-processed soil at two Provetus STF suggests lower quartile of 10%. Selection of 1% as reasonable worst-case.
 k for PM10

	PM2.5	PM10	PM30
k	0.15	1.5	4.9
a	0.9	0.9	0.7
b	0.45	0.45	0.45

Particle size	<30 µm	<15 µm	<10 µm	<5 µm	<2.5 µm
k	0.74	0.48	0.35	0.2	0.053

Justification

Additional notes from AP-42 guidance

Particle size	PM30	PM15	PM10	PM2.5
k	3.23	0.77	0.62	0.15

Location	Quarry	Sand and gravel processing	Landfill
sL (mean)	8.2	70	7.4

k for PM10
 Worst-case assumption
 Example for a Volvo A25 - 20t payload + 22t net weight
 Reasonable worst-case assumption
 Likely maximum speed given scale and layout of STF
 C for PM10

	Industrial roads			Public roads		
	PM2.5	PM10	PM30	PM2.5	PM10	PM30
k	0.15	1.5	4.9	0.18	1.8	6
a	0.9	0.9	0.7	1	1	1
b	0.45	0.45	0.45	-	-	-
c	-	-	-	0.2	0.2	0.3
d	-	-	-	0.5	0.5	0.3

a (empirical constant)
 b (empirical constant)
 c (empirical constant)
 d (empirical constant)

0.9	(-)
0.45	(-)
	(-)
	(-)

For PM10
 For PM10

C	0.00036	0.00047	0.00047
---	---------	---------	---------

Portable plants - crushing (11.19.2)

	Value	Units
EF (for TSP) (uncontrolled)	0.0027	kg/tonne(megagram)
EF (for TSP) (controlled)	0.0006	kg/tonne(megagram)
EF (for PM10) (uncontrolled)	0.0012	kg/tonne(megagram)
EF (for PM10) (controlled)	0.00027	kg/tonne(megagram)
Selected EF		kg/tonne(megagram)

Portable plants - screening (11.19.2)

	Value	Units
EF (for TSP) (uncontrolled)	0.0125	kg/tonne(megagram)
EF (for TSP) (controlled)	0.0011	kg/tonne(megagram)
EF (for PM10) (uncontrolled)	0.0043	kg/tonne(megagram)
EF (for PM10) (controlled)	0.00037	kg/tonne(megagram)
Selected EF	0.00037	kg/tonne(megagram)

EF for PM10 for controlled operations

Portable plants - conveyor transfer (11.19.2)

	Value	Units
EF (for TSP) (uncontrolled)	0.0015	kg/tonne(megagram)
EF (for TSP) (controlled)	0.00007	kg/tonne(megagram)
EF (for PM10) (uncontrolled)	0.00055	kg/tonne(megagram)
EF (for PM10) (controlled)	0.000023	kg/tonne(megagram)
Selected EF	0.000023	kg/tonne(megagram)

EF for PM10 for controlled operations

Portable plants - material transfers (13.4.2)

EF	0.003214834	kg per tonne(megagram)
U (mean wind speed)	4	m/s
M (material moisture content)	1	%
k (particle size multiplier)	0.35	(-)

Annual average wind speed for nearest Met Office climate station, and for the Midlands District is approximately 8 knots (4m/s)

Analysis of soil moisture for pre- and post-processed soil at two Provectus STF suggests lower quartile of 10%. Selection of 1% as reasonable worst-case.

k for PM10

Particle size	<30 µm	<15 µm	<10 µm	<5 µm	<2.5 µm
k	0.74	0.48	0.35	0.2	0.053

Aggregate Handling and Storage Piles (13.2.4)

Though drafted to consider outdoor storage piles of mineral aggregates, Section 13.2.4 of AP-42 may be utilised to model dust emissions from soil stockpiles. However, AP-42 assumes that stockpiles are left uncovered, which is unlikely to be the case with stockpiles of ACS on brownfield sites.

Dust emissions are modelled at various points:

- Movement of trucks and material loading onto stockpiles;
- Wind disturbance of piles;
- Loadout from the piles; and
- Movement of trucks and loading equipment within the storage pile area (i.e. site movement of plant).

The potential for dust emissions are at a peak when material is added to storage piles, as fines are easily disaggregated and released to the atmosphere, either through transfer from plant or due to high winds. The potential for emissions is significantly reduced as the stockpile weathers, due to aggregation and cementation of fines. Rainfall can soak the pile, and the drying process is slow.

AP-42 contains the following empirical expression, to estimate the quantity of particulate emissions generated per tonne of material stockpiled:

	Value	Units
E	0.003214834	kg per tonne of material moved
k (particle size multiplier)	0.35	(-)
U (mean wind speed)	4	m/s
M (material moisture content)	1	%

Justification Additional notes from AP-42 guidance

k for PM10
 Annual average wind speed for nearest Met Office climate station, and for the Midlands District is approximately 8 knots (4m/s)

Particle size	<30 µm	<15 µm	<10 µm	<5 µm	<2.5 µm
k	0.74	0.48	0.35	0.2	0.053

Analysis of soil moisture for pre- and post-processed soil at two Provectus STF suggests lower quartile of 10%. Selection of 1% as reasonable worst-case.

Industrial Wind Erosion (13.2.5)

	Value	Units
EF	0.591121	g/m ² per day
k (particle size multiplier)	0.5	(-)
P (erosion potential)	1182242	g/m ²
u' (frictional velocity)	0.583	m/s
ut (threshold friction velocity)	0.54	m/s
u (maximum wind speed at a height of 10m)	11	m/s

k for PM10

-ut for coal dust on concrete pad
Wind speed at which u'>ut (equivalent to a 'strong breeze')

k	Particle size	30 µm	<15 µm	<10 µm	<2.5 µm
	Material	1	0.6	0.5	0.075
		Threshold Friction Velocity (m/s)	Roughness Height (cm)	Threshold Wind Velocity At 10 m (m/s)	
				$z_0 = Act$	$z_0 = 0.8 cm$
Overburden ^a		1.02	0.3	21	19
Scoria (roadbed material) ^b		1.33	0.3	27	25
Gravel coal (surrounding coal pile) ^c		0.55	0.01	16	10
Uncrested coal pile ^d		1.12	0.3	23	21
Scraper tracks on coal pile ^{e,h}		0.62	0.06	15	12
Fine coal dust on concrete pad ^f		0.54	0.2	11	10

All information taken from AP-42: *Compilation of Air Pollutant Emission Factors, 5th edition, Volume 1, Chapter 13: Miscellaneous Sources, 1995-2011*
<https://www.epa.gov/air-emissions-factors-and-quantification/ap-42-fifth-edition-volume-i-chapter-13-miscellaneous-0>

Estimated airborne dust concentrations based on AP-42 EFs

	Value	Units
h (height of mixing zone box)	2	m
W (width of mixing zone box perpendicular to wind direction)	50	m
u (mean wind speed through box)	4	m/s

Supporting information
Selected to reasonably reflect air mass sampled by air monitoring instrumentation
Reasonable reflection of operational scale
Annual average wind speed for nearest Met Office climate station, and for the Midlands District is approximately 8 knots (4m/s)

Generic heavy construction activity emissions

EF (TSP emission rate)	0.00E+00	kg per month
A (activity rate)		number of days of activity per month
C (dust concentration)	0.00E+00	mg/m ³

[Assumes 10hrs activity per day]

Demolition and clearance

General land clearance (11.9.2)

EF (calculated PM10 emission rate)	#DIV/0!	kg per hour
A (activity rate)		hour
C (dust concentration)	#DIV/0!	mg/m ³

[Set at one unit as concentration is independent of time]

Loading / unloading material into trucks (13.2.4)

EF (calculated emission rate)	#DIV/0!	kg per tonne
A (activity rate)		tonnes of material moved per hour
C (dust concentration)	#DIV/0!	mg/m ³

Transporting of material by truck (paved road) (13.2.1)

EF (calculated emission rate)	0.00E+00	g per VKT
A (activity rate)		VKT per hour
C (dust concentration)	0.00E+00	mg/m ³

Transporting of material by truck (unpaved road) (13.2.2)

EF (calculated emission rate)	1.22E+04	g per VKT
A (activity rate)		VKT per hour
C (dust concentration)	0.00E+00	mg/m ³

Site preparation (earthworks)

Bulldozing (11.9.2)

EF (calculated PM10 emission rate)	#DIV/0!	kg per hour
A (activity rate)		hour
C (dust concentration)	#DIV/0!	mg/m ³

[Set at one unit as concentration is independent of time]

Scrapers unloading topsoil (11.9.2)

EF (calculated emission rate)	2.00E-02	kg per tonne
A (activity rate)		tonnes of material moved per hour
C (dust concentration)	0.00E+00	mg/m ³

Scrapers in travel (13.2.2)

EF (calculated emission rate)	#NUM!	g/VKT
A (activity rate)		VKT per hour
C (dust concentration)	#NUM!	mg/m ³

Scrapers removing topsoil (11.9.2 & 13.2.4)

EF (calculated emission rate)	2.90E-02	kg per tonne
A (activity rate)		tonnes of material moved per hour
C (dust concentration)	0.00E+00	mg/m ³
Alternative EF	5.70E+00	kg per VKT
Alternative A		VKT per hour
Alternative C	0.00E+00	mg/m ³

Loading / unloading material into trucks (13.2.4)

EF (calculated emission rate)	3.21E-03	kg per tonne	Assumption of 500 tonne process rate per day (8 hours) based on Provectus information on typical STF operations
A (activity rate)	62.5	tonnes of material moved per hour	
C (dust concentration)	1.40E-01	mg/m ³	

Compacting (11.9.2)

EF (calculated PM10 emission rate)	#DIV/0!	kg per hour	[Set at one unit as concentration is independent of time]
A (activity rate)		hour	
C (dust concentration)	#DIV/0!	mg/m ³	

Grading (11.9.2)

EF (calculated PM10 emission rate)	0.00E+00	kg per VKT
A (activity rate)		VKT per hour
C (dust concentration)	0.00E+00	mg/m ³

General Construction

Vehicular traffic (paved road) (13.2.1)

EF (calculated emission rate)	0.00E+00	g per VKT
A (activity rate)		VKT per hour
C (dust concentration)	0.00E+00	mg/m ³

Vehicular traffic (unpaved road) (13.2.2)

EF (calculated emission rate)	1.22E+04	g per VKT	Assumption that vehicle movements limited to approximately 100 m per hour (e.g. transfer from process stockpile to storage stockpile)
A (activity rate)	0.1	VKT per hour	
C (dust concentration)	8.47E-01	mg/m ³	

Portable plants - crushing (11.19.2)

EF (calculated emission rate)	0.00E+00	kg per tonne
A (activity rate)		tonnes of material moved per hour
C (dust concentration)	0.00E+00	mg/m ³

Portable plants - screening (11.19.2)

EF (calculated emission rate)	3.70E-04	kg per tonne	Assumption of 500 tonne process rate per day (8 hours) based on Provecus information on typical STF operations
A (activity rate)	62.5	tonnes of material moved per hour	
C (dust concentration)	1.61E-02	mg/m ³	

Portable plants - conveyor transfer (11.19.2)

EF (calculated emission rate)	2.30E-05	kg per tonne	Assumption of 150 tonne process rate per day (8 hours) based on Provecus information on typical STF operations for picking station
A (activity rate)	18.75	tonnes of material moved per hour	
C (dust concentration)	2.99E-04	mg/m ³	

Portable plants - material transfers (13.4.2)

EF (calculated emission rate)	3.21E-03	kg per tonne	Assumption of 500 tonne process rate per day (8 hours) based on Provecus information on typical STF operations
A (activity rate)	62.5	tonnes of material moved per hour	
C (dust concentration)	1.40E-01	mg/m ³	

Aggregate Handling and Storage Piles (13.2.4)

EF (calculated emission rate)	3.21E-03	kg per tonne of material moved
A (activity rate)	62.5	tonnes of material handled per hour
C (dust concentration)	1.40E-01	mg/m ³

Industrial Wind Erosion (13.2.5)

EF (calculated emission rate)	5.91E-01	g per m ² surface area per day	Note: this is only relevant if wind speed during day exceeds threshold wind speed Approximate estimate of potential STF exposed slab area for proposed scale of STF (50% of a 50m x 50m area) Assumes a daily disturbance duration of 8 hours
A (activity rate)	1250	ground surface area of interest (m ²)	
C (dust concentration)	6.41E-02	mg/m ³	

AP-42 calculations for industrial wind erosion only and for stockpile overburden as opposed to concrete slab dust

Approaches to dust emission estimation detailed in US EPA AP-42

US EPA Air Emission Factors and Quantification. AP-42: Compilation of Air Emission Factors.

These calculations are all reproduced from the guidance contained here <https://www.epa.gov/air-emissions-factors-and-quantification/ap-42-Compilation-air-emissions-factors>.

AP-42 is the primary source used by the US EPA for information concerning emissions factors, developed and compiled from test data and engineering estimates. The emission factors represent the average of the range of emission rates evaluated.

The overarching equation for emissions is:

$$E = A \times EF \times (1 - ER) / 100$$

- E = emissions
- A = activity rate
- EF = emission factor
- ER = overall emission reduction efficiency (%)

An estimate of the resultant fugitive airborne dust concentration can be calculated using a simple box model:

$$C = E / h \times W \times u$$

- C = airborne dust concentration
- h = height of mixing zone box
- W = width of mixing zone perpendicular to wind direction
- u = mean wind speed through box

Section 13.2 of AP-42 covers fugitive dust sources, estimating dust emissions from the disturbance of granular material, and consequently is the most relevant section of AP-42 for considering emissions from brownfield activities. The two main physical actions involved in this process are the pulverisation and abrasion of surface materials by the application of mechanical force, and the entrainment of dust particles by the action of turbulent air currents.

Heavy Construction Operations (13.2.3)

Section 13.2.3 provides some very broad estimates with regard to dust emissions from construction operations. Essentially, dust emissions are considered proportional to the site size and the level of construction activity taking place.

The following emission factor is included in AP-42 for heavy construction activities:

	Value	Units	
EF (TSP emission factor)	0	kg per ha per month	TSP = total suspended solids (will over-estimate PM10 concentration)
Area in which activity is taking place		ha	Assumes 30 days of continuous activity per month

These emission factors are most applicable to operations with a medium level of activity, moderate silt content and a semi-arid climate, and are likely to result in unrealistically high PM-10 estimates. In practice emissions from construction activities will vary substantially over the duration of the project. As a result, AP-42 recommends that construction activities are broken down into component operations. Recommended emission factors are provided in Table 13.2.3-1 as follows:

Construction Phase	Dust Generating Activities	Recommended Emission Factor
Demolition and clearance	General land clearance	Dozer equation (overburden) in Tables 11.9-1 and 11.9-2
	Loading of material into trucks	Material handling equation (section 13.2.4)
	Truck transport of material	Unpaved road equation (section 13.2.2) or paved road equation (section 13.2.1)
	Truck unloading of material	Material handling equation (section 13.2.4)
Site preparation (earthworks)	Bulldozing	Dozer equation (overburden) in Tables 11.9-1 and 11.9-2
	Scrapers unloading topsoil	Scraper unloading factor in Table 11.9-4
	Scrapers in travel	Scraper (travel mode) equation in Tables 11.9-1 and 11.9-2 (unpaved road emission factor equation in AP-42 Section 13.2.2)
	Scrapers removing topsoil	EF = 5.7kg per vehicle km travelled (VKT)
	Loading excavated material into trucks	Material handling equation (section 13.2.4)
	Truck dumping of fill material, road base, or other materials	Material handling equation (section 13.2.4)
	Compacting	Dozer equation (overburden) in Tables 11.9-1 and 11.9-2
	Grading	Grading equation in Tables 11.9-1 and 11.9-2
General construction	Vehicular traffic	Unpaved road equation (section 13.2.2) or paved road equation (section 13.2.1)
	Portable plants - crushing	Factors for similar material/operations in section 11.19.2
	Portable plants - screening	Factors for similar material/operations in section 11.19.2
	Portable plants - material transfers	Material handling equation (section 13.2.4)

The following section is also likely to be of relevance when considering emissions from brownfield activities:
 13.2.5 - Industrial Wind Erosion

Demolition and clearance

General land clearance (11.9.2)

	Value	Units
EF (for TSP <30µm)	#DIV/o!	kg per hour
EF (for PM10)	#DIV/o!	kg per hour
s (material silt content)		%
M (material moisture content)		%

Loading / unloading material into trucks (13.2.4)

	Value	Units
EF	#DIV/o!	kg per tonne(megagram)
U (mean wind speed)		m/s
M (material moisture content)		%
k (particle size multiplier)		(-)

Transporting of material by truck (13.2.1 and 13.2.2)

Paved road

	Value	Units
EF	0	g per VKT
k (particle size multiplier)		g/VKT
sL (road surface silt loading)		g/m ²
W (weight of vehicle)		tons

Unpaved road

	Value	Units
EF (industrial sites)	#NUM!	g/VKT
EF (light vehicles using public roads)	#NUM!	g/VKT
k (particle size multiplier)		lb/VMT
s (surface material silt content)		%
W (mean vehicle weight)		tons
M (surface material moisture content)		%
S (mean vehicle speed)		mph
C (emission factor for exhaust, brake and tyre wear)		lb/VMT
a (empirical constant)		(-)
b (empirical constant)		(-)
c (empirical constant)		(-)
d (empirical constant)		(-)

Site preparation (earthworks)

Bulldozing (11.9.2)

	Value	Units
EF (for TSP <30µm)	#DIV/o!	kg per hour
EF (for PM10)	#DIV/o!	kg per hour
s (material silt content)		%
M (material moisture content)		%

Justification Additional notes from AP-42 guidance

Particle size	<30 µm	<15 µm	<10 µm	<5 µm	<2.5 µm
k	0.74	0.48	0.35	0.2	0.053

Particle size	PM30	PM15	PM10	PM2.5
k	3.23	0.77	0.62	0.15

Location	Quarry	Sand and gravel processing	Landfill
sL (mean)	8.2	70	7.4

	Industrial roads			Public roads		
	PM2.5	PM10	PM30	PM2.5	PM10	PM30
k	0.15	1.5	4.9	0.18	1.8	6
a	0.9	0.9	0.7	1	1	1
b	0.45	0.45	0.45	-	-	-
c	-	-	-	0.2	0.2	0.3
d	-	-	-	0.5	0.5	0.3

C	0.00036	0.00047	0.00047
---	---------	---------	---------

Justification Additional notes from AP-42 guidance

Scrapers unloading topsoil (11.9.2)

Value	Units
0.02	kg/tonne(megagram)

Scrapers in travel (13.2.2)

Value	Units
#NUM!	g/VKT
	lb/VMT
	%
	tons
	(-)
	(-)

Scrapers removing topsoil (11.9.2 & 13.2.4)

Value	Unit
0.029	kg/tonne(megagram)
5.7	kg/VKT

Loading / unloading material into trucks (13.2.4)

Value	Units
#DIV/0!	kg per tonne(megagram)
	m/s
	%
	(-)

Compacting (11.9.2)

Value	Units
#DIV/0!	kg per hour
#DIV/0!	kg per hour
	%
	%

Grading (11.9.2)

Value	Units
0	kg/VKT
0	kg/VKT
	kph

General Construction

Justification

Additional notes from AP-42 guidance

	PM2.5	PM10	PM30
k	0.15	1.5	4.9
a	0.9	0.9	0.7
b	0.45	0.45	0.45

Particle size	<30 µm	<15 µm	<10 µm	<5 µm	<2.5 µm
k	0.74	0.48	0.35	0.2	0.053

Vehicular traffic (13.2.1 & 13.2.2)

Value	Units
0	g per VKT
	g/VKT
	g/m ²
	tons

Unpaved road

Value	Units
#NUM!	g/VKT
0	g/VKT
	lb/VMT
	%
	%
	tons
	%
	mph
	lb/VMT

Particle size	PM30	PM15	PM10	PM2.5
k	3.23	0.77	0.62	0.15

Location	Quarry	Sand and gravel processing	Landfill
sL (mean)	8.2	70	7.4

	Industrial roads			Public roads		
	PM2.5	PM10	PM30	PM2.5	PM10	PM30
k	0.15	1.5	4.9	0.18	1.8	6
a	0.9	0.9	0.7	1	1	1
b	0.45	0.45	0.45	-	-	-
c	-	-	-	0.2	0.2	0.3
d	-	-	-	0.5	0.5	0.3

a (empirical constant)		(-)
b (empirical constant)		(-)
c (empirical constant)		(-)
d (empirical constant)		(-)

C	0.00036	0.00047	0.00047
---	---------	---------	---------

Portable plants - crushing (11.19.2)

	Value	Units
EF (for TSP) (uncontrolled)	0.0027	kg/tonne(megagram)
EF (for TSP) (controlled)	0.0006	kg/tonne(megagram)
EF (for PM10) (uncontrolled)	0.0012	kg/tonne(megagram)
EF (for PM10) (controlled)	0.00027	kg/tonne(megagram)
Selected EF		kg/tonne(megagram)

Portable plants - screening (11.19.2)

	Value	Units
EF (for TSP) (uncontrolled)	0.0125	kg/tonne(megagram)
EF (for TSP) (controlled)	0.0011	kg/tonne(megagram)
EF (for PM10) (uncontrolled)	0.0043	kg/tonne(megagram)
EF (for PM10) (controlled)	0.00037	kg/tonne(megagram)
Selected EF		kg/tonne(megagram)

Portable plants - conveyor transfer (11.19.2)

	Value	Units
EF (for TSP) (uncontrolled)	0.0015	kg/tonne(megagram)
EF (for TSP) (controlled)	0.00007	kg/tonne(megagram)
EF (for PM10) (uncontrolled)	0.00055	kg/tonne(megagram)
EF (for PM10) (controlled)	0.000023	kg/tonne(megagram)
Selected EF		kg/tonne(megagram)

Portable plants - material transfers (13.4.2)

	Value	Units
EF	#DIV/0!	kg per tonne(megagram)
U (mean wind speed)		m/s
M (material moisture content)		%
k (particle size multiplier)		(-)

Particle size	<30 µm	<15 µm	<10 µm	<5 µm	<2.5 µm
k	0.74	0.48	0.35	0.2	0.053

Aggregate Handling and Storage Piles (13.2.4)

Though drafted to consider outdoor storage piles of mineral aggregates, Section 13.2.4 of AP-42 may be utilised to model dust emissions from soil stockpiles. However, AP-42 assumes that stockpiles are left uncovered, which is unlikely to be the case with stockpiles of ACS on brownfield sites.

Dust emissions are modelled at various points:

- Movement of trucks and material loading onto stockpiles;
- Wind disturbance of piles;
- Loadout from the piles; and
- Movement of trucks and loading equipment within the storage pile area (i.e. site movement of plant).

The potential for dust emissions are at a peak when material is added to storage piles, as fines are easily disaggregated and released to the atmosphere, either through transfer from plant or due to high winds. The potential for emissions is significantly reduced as the stockpile weathers, due to aggregation and cementation of fines. Rainfall can soak the pile, and the drying process is slow.

AP-42 contains the following empirical expression, to estimate the quantity of particulate emissions generated per tonne of material stockpiled:

	Value	Units
E	#DIV/0!	kg per tonne of material moved
k (particle size multiplier)		(-)
U (mean wind speed)		m/s
M (material moisture content)		%

Justification Additional notes from AP-42 guidance

Particle size	<30 µm	<15 µm	<10 µm	<5 µm	<2.5 µm
k	0.74	0.48	0.35	0.2	0.053

Industrial Wind Erosion (13.2.5)

	Value	Units
EF	0.5464	g/m ³ per day
k (particle size multiplier)	0.5	(-)
P (erosion potential)	1.0928	g/m ³
u' (frictional velocity)	1.06	m/s
ut (threshold friction velocity)	1.02	m/s
u (maximum wind speed at a height of 10m)	20	m/s

k for PM10

-ut for overburden

Wind speed at which u' > ut (equivalent to a 'gale')

Particle size	30 µm	<15 µm	<10 µm	<2.5 µm
	1	0.6	0.5	0.075
k				
Material	Threshold Friction Velocity (m/s)	Roughness Height (cm)	Threshold Wind Velocity At 10 m (m/s)	
			z ₀ = Act	z ₀ = 0.5 cm
Overburden ^a	1.02	0.3	21	19
Scoria (roadbed material) ^b	1.33	0.3	27	25
Gravel coal (surrounding coal pile) ^c	0.55	0.01	16	10
Uncoated coal pile ^d	1.12	0.3	23	21
Scraper tracks on coal pile ^{d,b}	0.62	0.06	15	12
Fine coal dust on concrete pad ^e	0.54	0.2	11	10

All information taken from AP-42: *Compilation of Air Pollutant Emission Factors, 5th edition, Volume 1, Chapter 13: Miscellaneous Sources, 1995-2011*
<https://www.epa.gov/air-emissions-factors-and-quantification/ap-42-fifth-edition-volume-i-chapter-13-miscellaneous-0>

Estimated airborne dust concentrations based on AP-42 EFs

	Value	Units
h (height of mixing zone box)	2	m
W (width of mixing zone box perpendicular to wind direction)	50	m
u (mean wind speed through box)	4	m/s

Supporting information
 Selected to reasonably reflect air mass sampled by air monitoring instrumentation
 Reasonable reflection of operational scale
 Annual average wind speed for nearest Met Office climate station, and for the Midlands District is approximately 8 knots (4m/s)

Generic heavy construction activity emissions

EF (TSP emission rate)	0.00E+00	kg per month
A (activity rate)		number of days of activity per month
C (dust concentration)	0.00E+00	mg/m ³

[Assumes 10hrs activity per day]

Demolition and clearance

General land clearance (11.9.2)

EF (calculated PM10 emission rate)	#DIV/0!	kg per hour
A (activity rate)		hour
C (dust concentration)	#DIV/0!	mg/m ³

[Set at one unit as concentration is independent of time]

Loading / unloading material into trucks (13.2.4)

EF (calculated emission rate)	#DIV/0!	kg per tonne
A (activity rate)		tonnes of material moved per hour
C (dust concentration)	#DIV/0!	mg/m ³

Transporting of material by truck (paved road) (13.2.1)

EF (calculated emission rate)	0.00E+00	g per VKT
A (activity rate)		VKT per hour
C (dust concentration)	0.00E+00	mg/m ³

Transporting of material by truck (unpaved road) (13.2.2)

EF (calculated emission rate)	#NUM!	g per VKT
A (activity rate)		VKT per hour
C (dust concentration)	#NUM!	mg/m ³

Site preparation (earthworks)

Bulldozing (11.9.2)

EF (calculated PM10 emission rate)	#DIV/0!	kg per hour
A (activity rate)		hour
C (dust concentration)	#DIV/0!	mg/m ³

[Set at one unit as concentration is independent of time]

Scrapers unloading topsoil (11.9.2)

EF (calculated emission rate)	2.00E-02	kg per tonne
A (activity rate)		tonnes of material moved per hour
C (dust concentration)	0.00E+00	mg/m ³

Scrapers in travel (13.2.2)

EF (calculated emission rate)	#NUM!	g/VKT
A (activity rate)		VKT per hour
C (dust concentration)	#NUM!	mg/m ³

Scrapers removing topsoil (11.9.2 & 13.2.4)

EF (calculated emission rate)	2.90E-02	kg per tonne
A (activity rate)		tonnes of material moved per hour
C (dust concentration)	0.00E+00	mg/m ³
Alternative EF	5.70E+00	kg per VKT
Alternative A		VKT per hour
Alternative C	0.00E+00	mg/m ³

Loading / unloading material into trucks (13.2.4)

EF (calculated emission rate)	#DIV/0!	kg per tonne
A (activity rate)		tonnes of material moved per hour
C (dust concentration)	#DIV/0!	mg/m ³

Compacting (11.9.2)

EF (calculated PM10 emission rate)	#DIV/0!	kg per hour
A (activity rate)		hour
C (dust concentration)	#DIV/0!	mg/m ³

[Set at one unit as concentration is independent of time]

Grading (11.9.2)

EF (calculated PM10 emission rate)	0.00E+00	kg per VKT
A (activity rate)		VKT per hour
C (dust concentration)	0.00E+00	mg/m ³

General Construction

Vehicular traffic (paved road) (13.2.1)

EF (calculated emission rate)	0.00E+00	g per VKT
A (activity rate)		VKT per hour
C (dust concentration)	0.00E+00	mg/m ³

Vehicular traffic (unpaved road) (13.2.2)

EF (calculated emission rate)	#NUM!	g per VKT
A (activity rate)		VKT per hour
C (dust concentration)	#NUM!	mg/m ³

Portable plants - crushing (11.19.2)

EF (calculated emission rate)	0.00E+00	kg per tonne
A (activity rate)		tonnes of material moved per hour
C (dust concentration)	0.00E+00	mg/m ³

Portable plants - screening (11.19.2)

EF (calculated emission rate)	0.00E+00	kg per tonne
A (activity rate)		tonnes of material moved per hour
C (dust concentration)	0.00E+00	mg/m ³

Portable plants - conveyor transfer (11.19.2)

EF (calculated emission rate)	0.00E+00	kg per tonne
A (activity rate)		tonnes of material moved per hour
C (dust concentration)	0.00E+00	mg/m ³

Portable plants - material transfers (11.4.2)

EF (calculated emission rate)	#DIV/0!	kg per tonne
A (activity rate)		tonnes of material moved per hour
C (dust concentration)	#DIV/0!	mg/m ³

Aggregate Handling and Storage Piles (13.2.4)

EF (calculated emission rate)	#DIV/0!	kg per tonne of material moved
A (activity rate)		tonnes of material handled per hour
C (dust concentration)	#DIV/0!	mg/m ³

Industrial Wind Erosion (13.2.5)

EF (calculated emission rate)	5.46E-01	g per m ² surface area per day
A (activity rate)	125	ground surface area of interest (m ²)
C (dust concentration)	5.93E-03	mg/m ³

Note: this is only relevant if wind speed during day exceeds threshold wind speed
 Approximate estimate of potential 511- exposed stockpile surface area for proposed scale of STF (rectangular stockpile with height of 3m and sides no more than 5m x 10m). Assumed reasonable worst-case surface area for wind erosion = 2 x sides (5x10) + flat top (5x5).

Appendix C TSI DustTrak DRZ Aerosol Monitor 8534 results for Maw Green STF

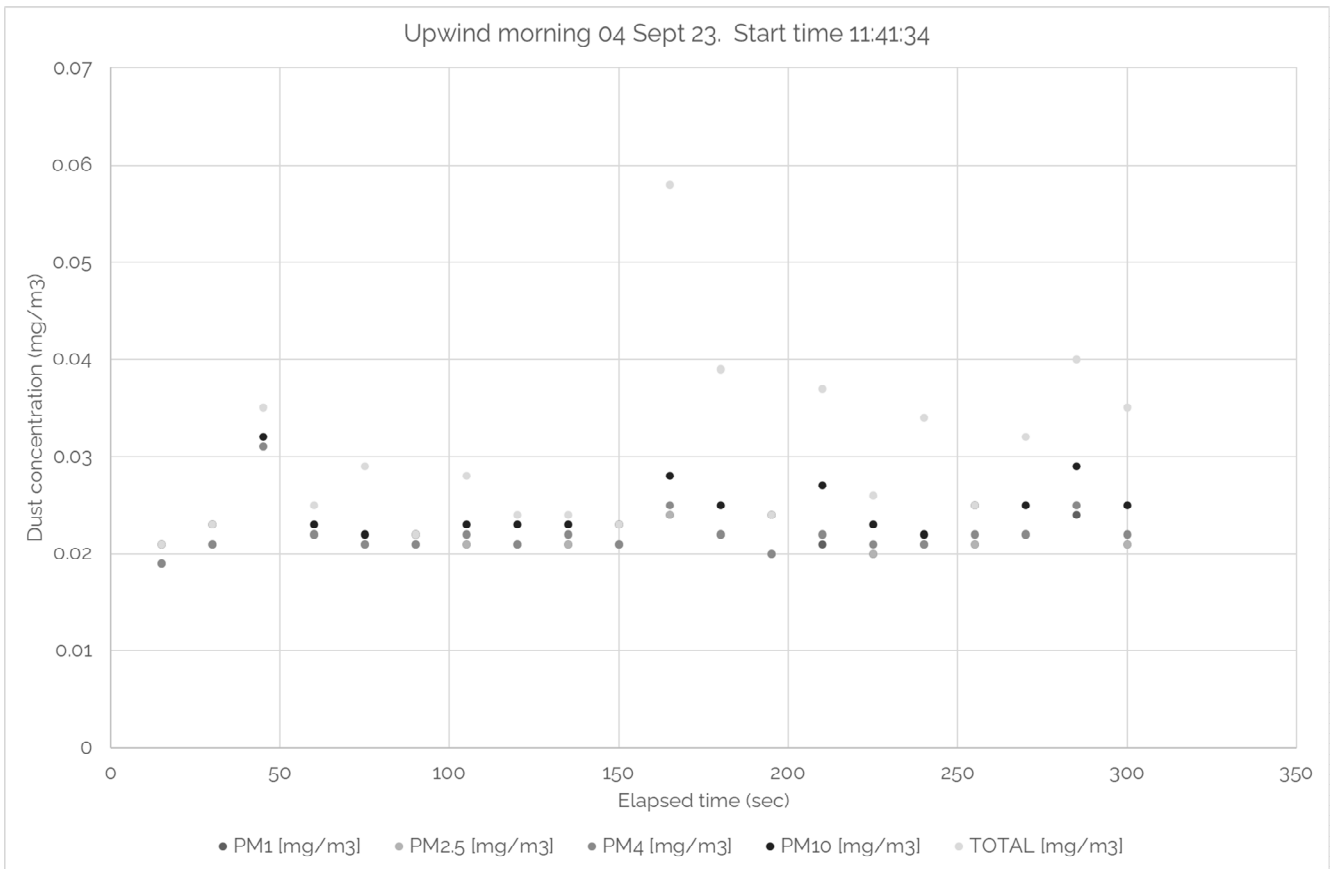
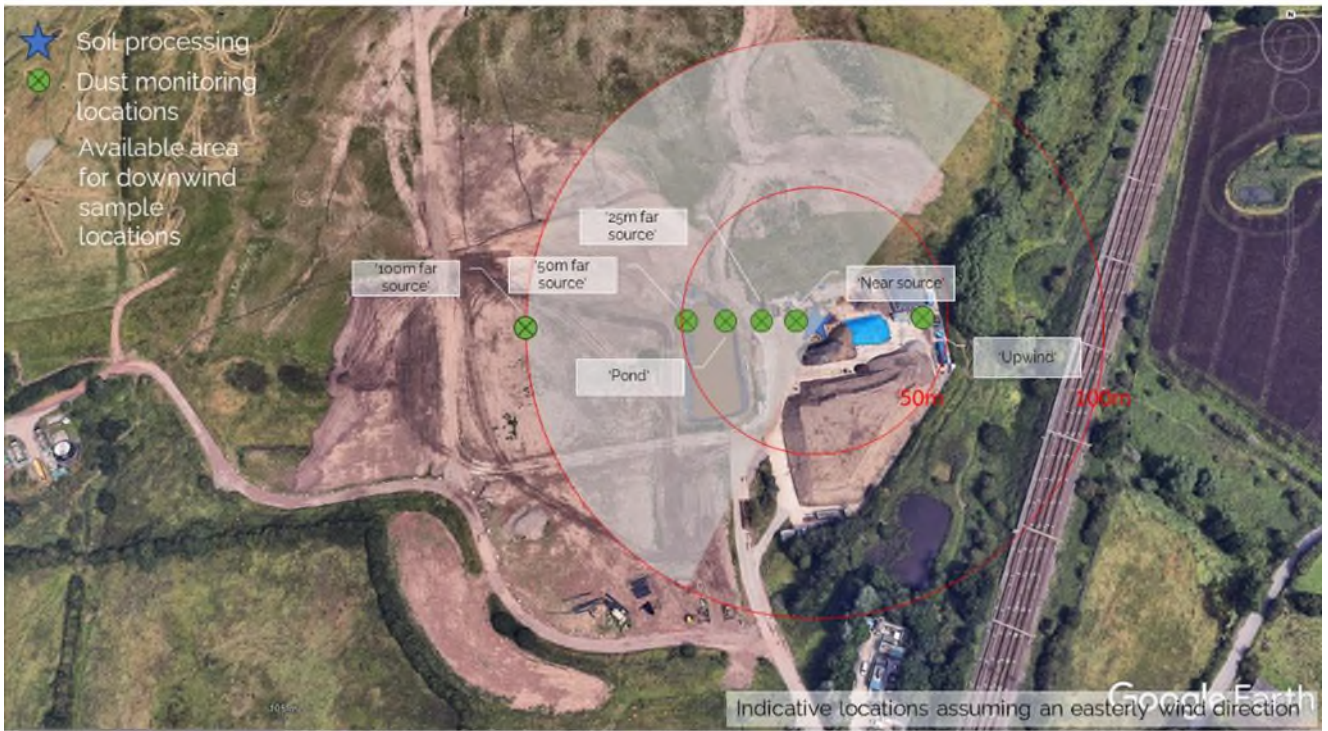

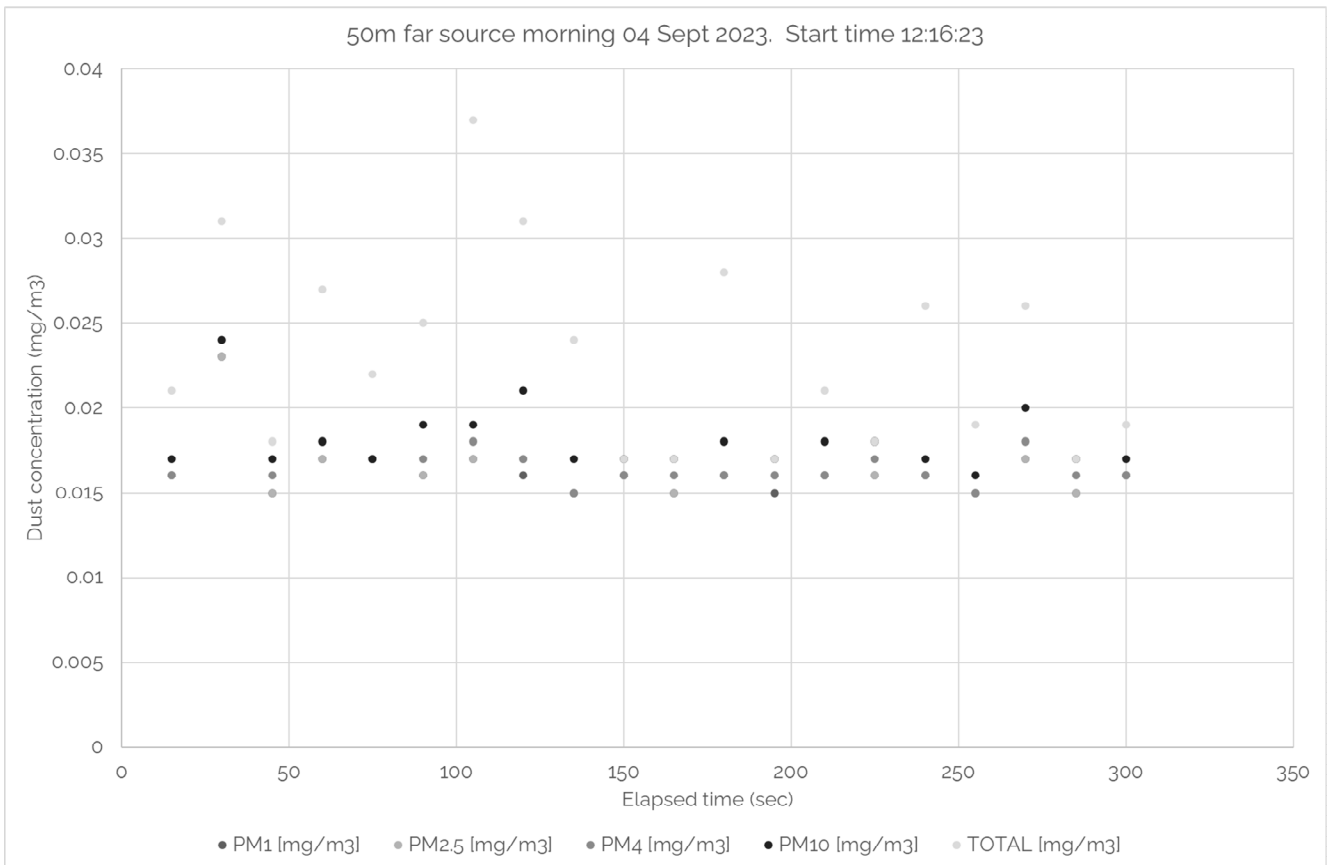
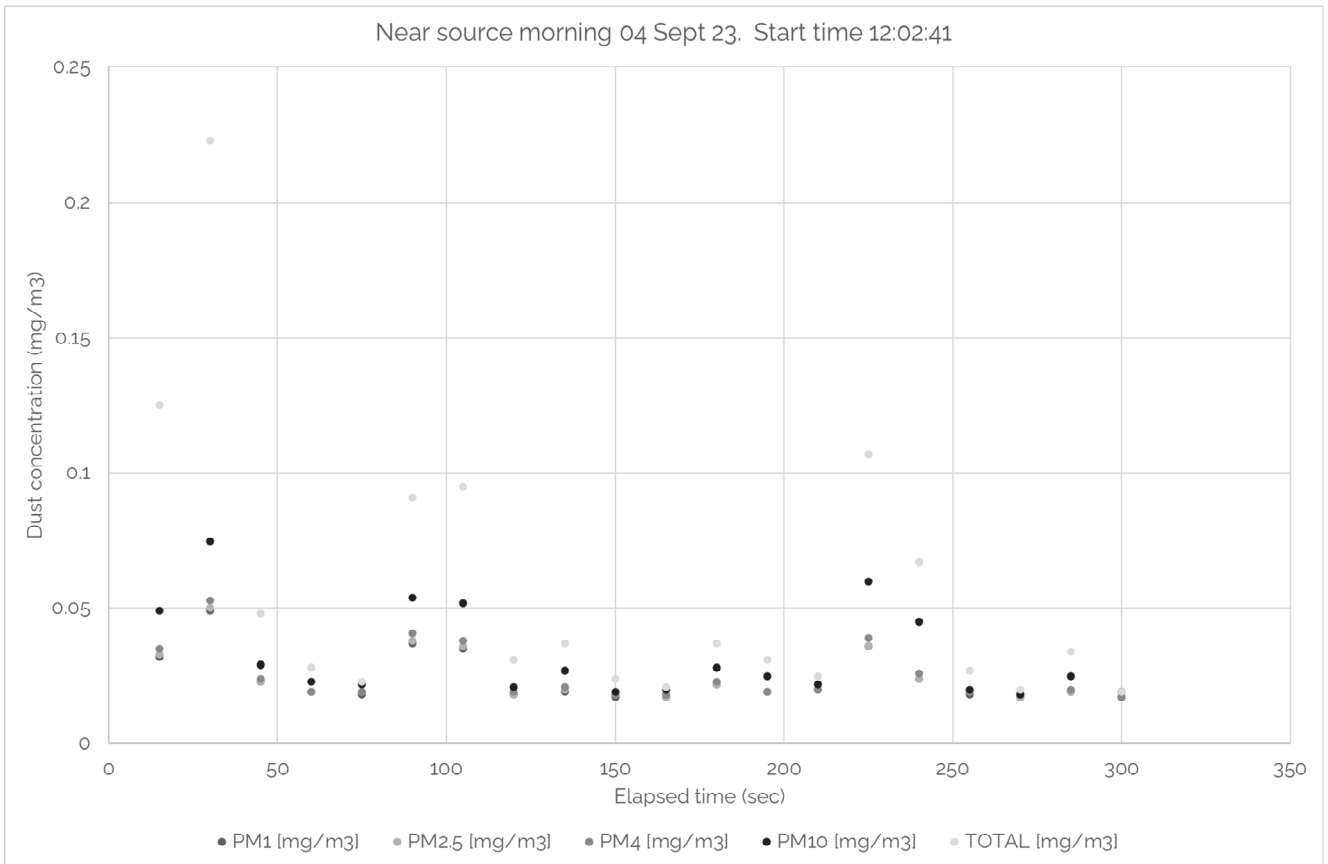

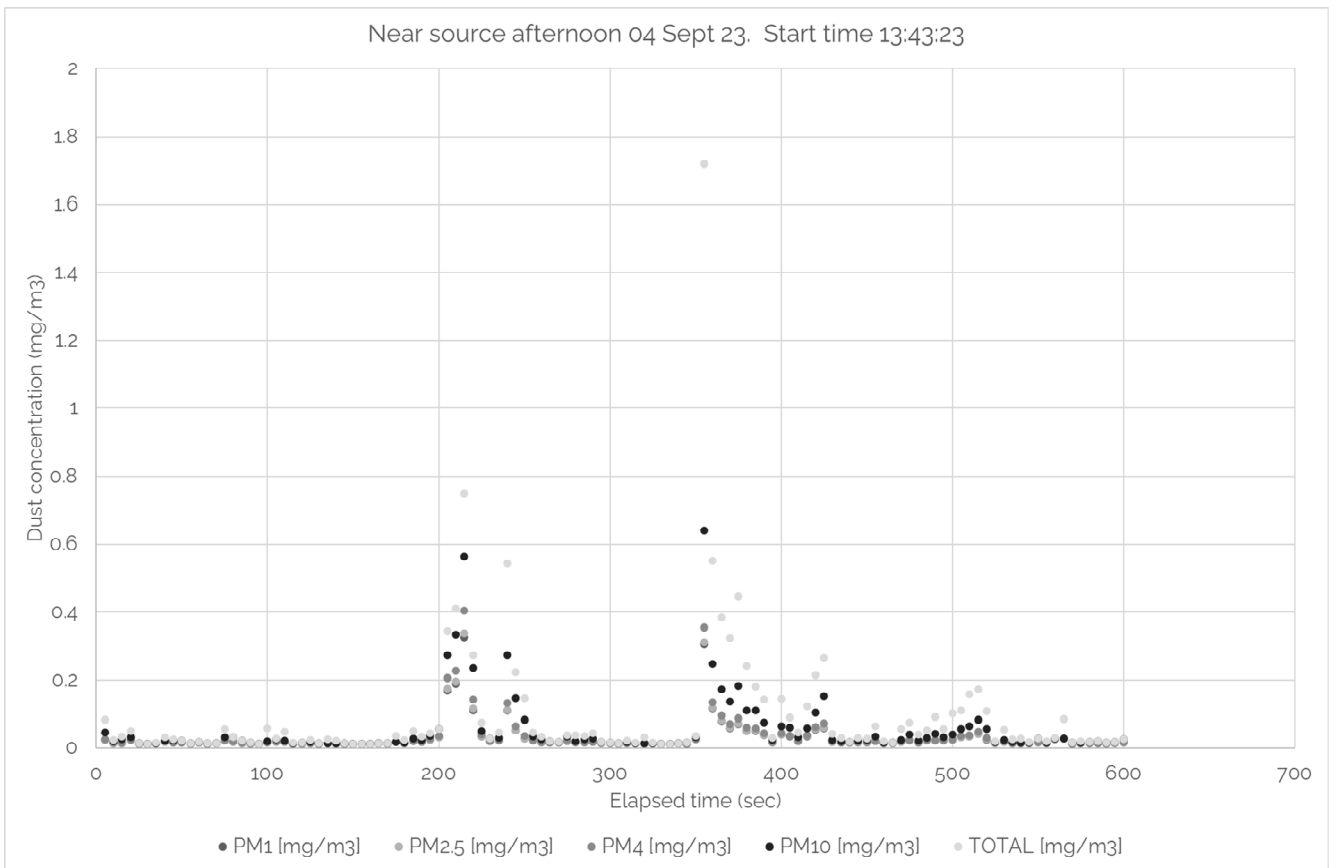
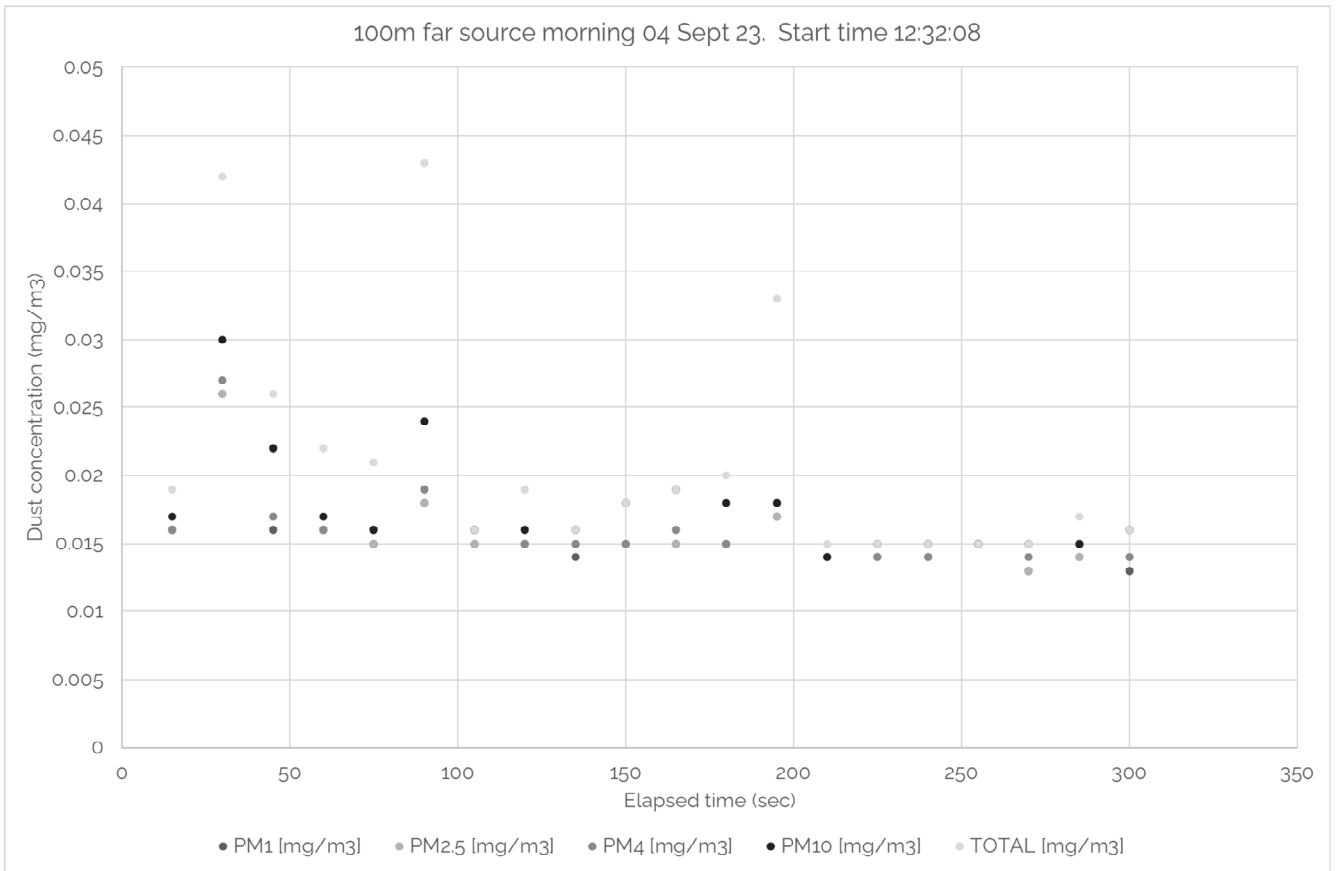

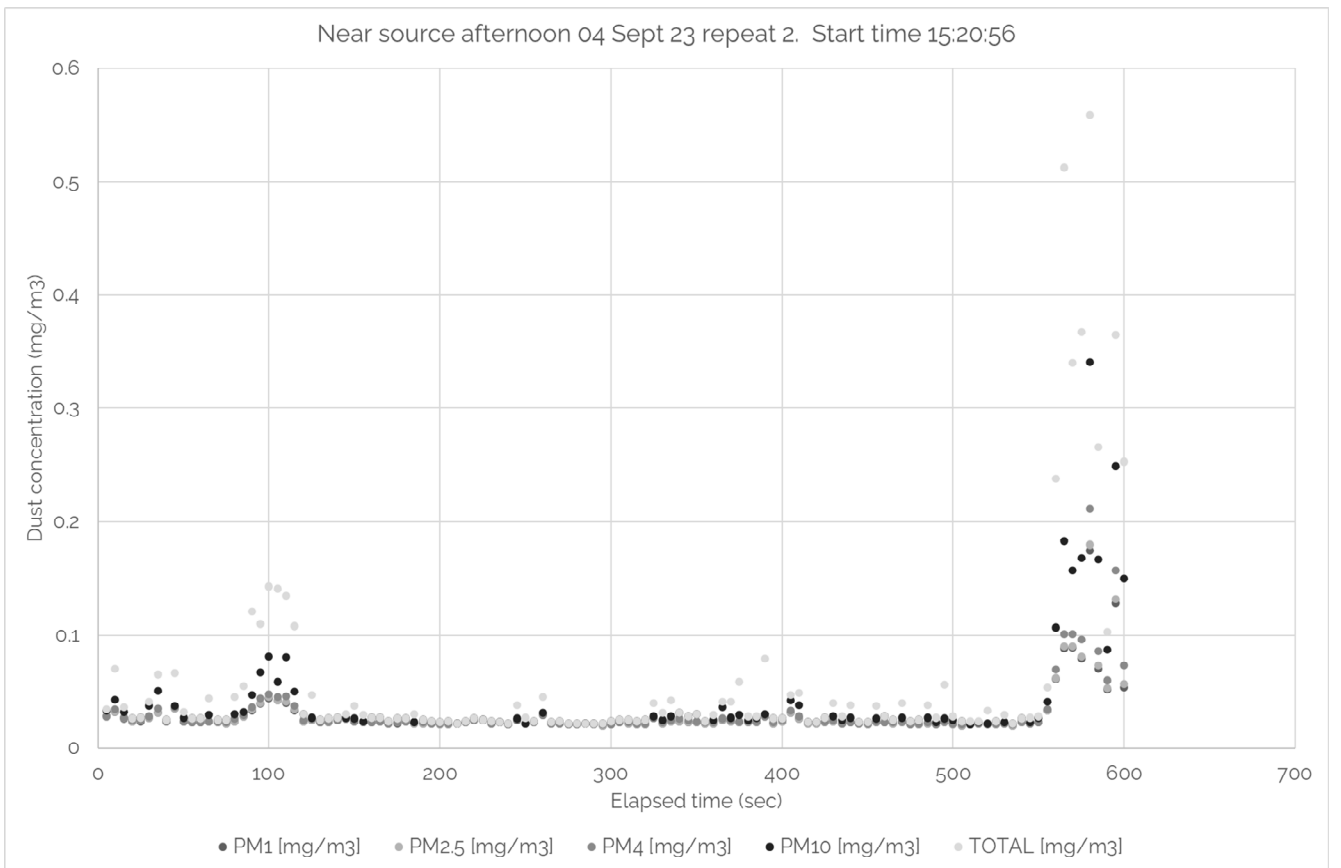
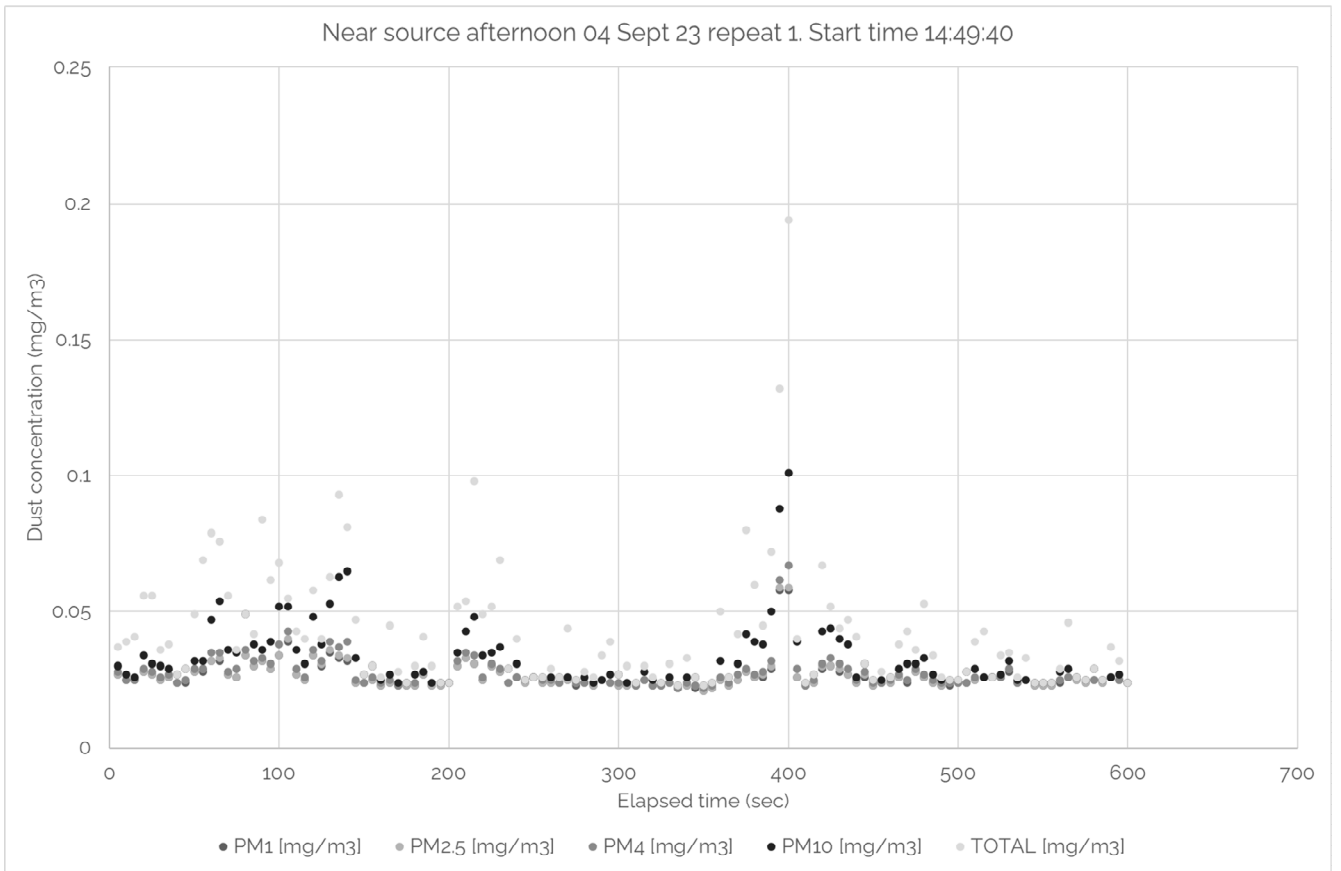

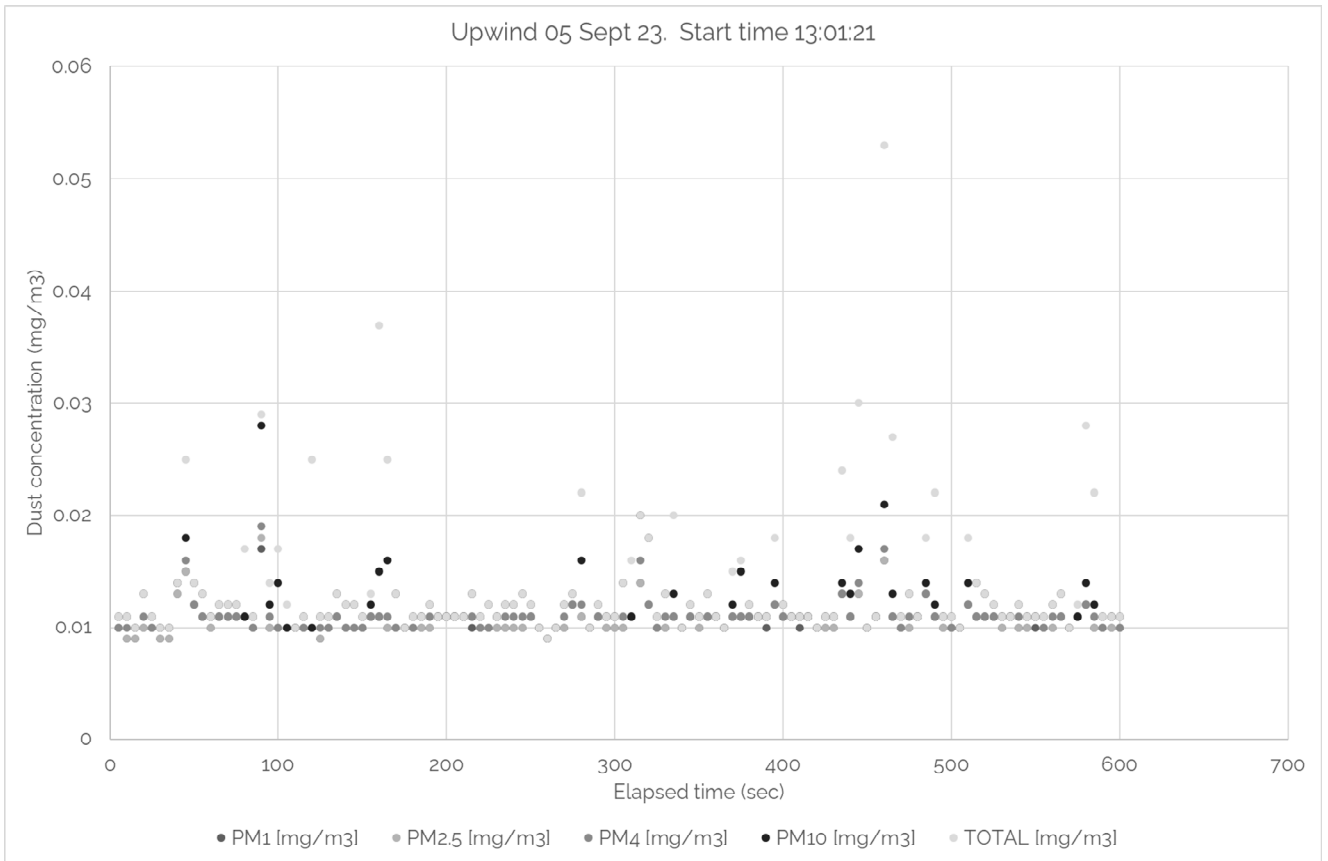
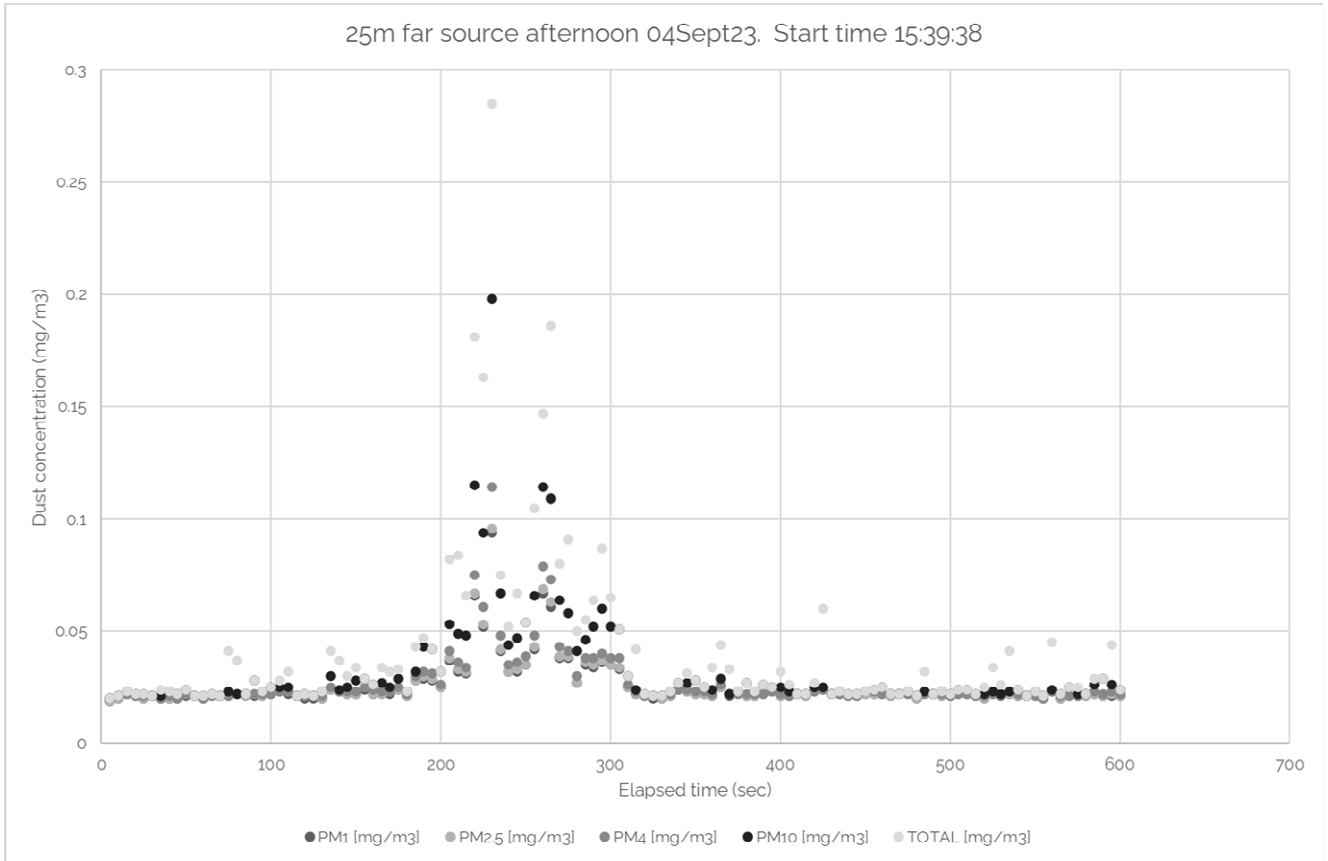

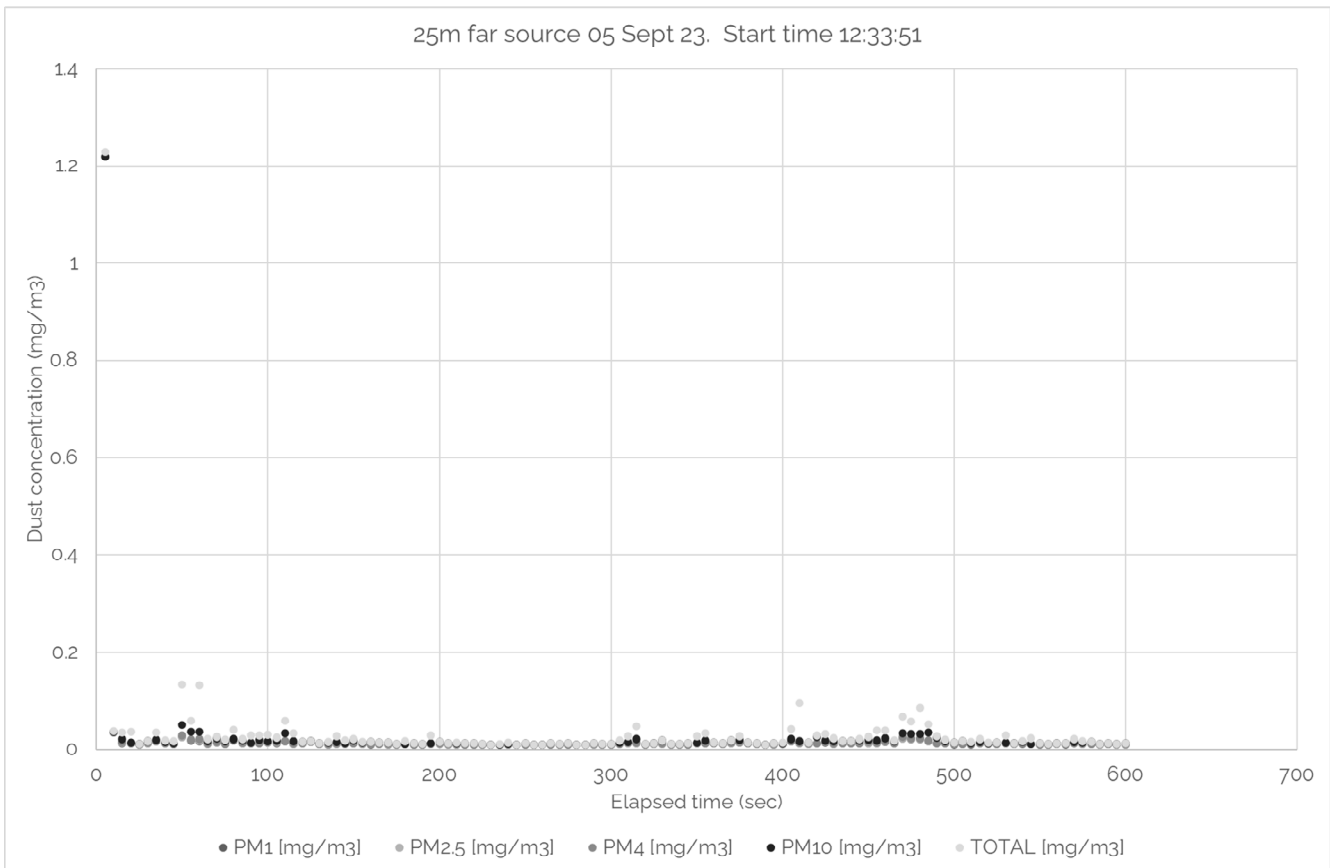
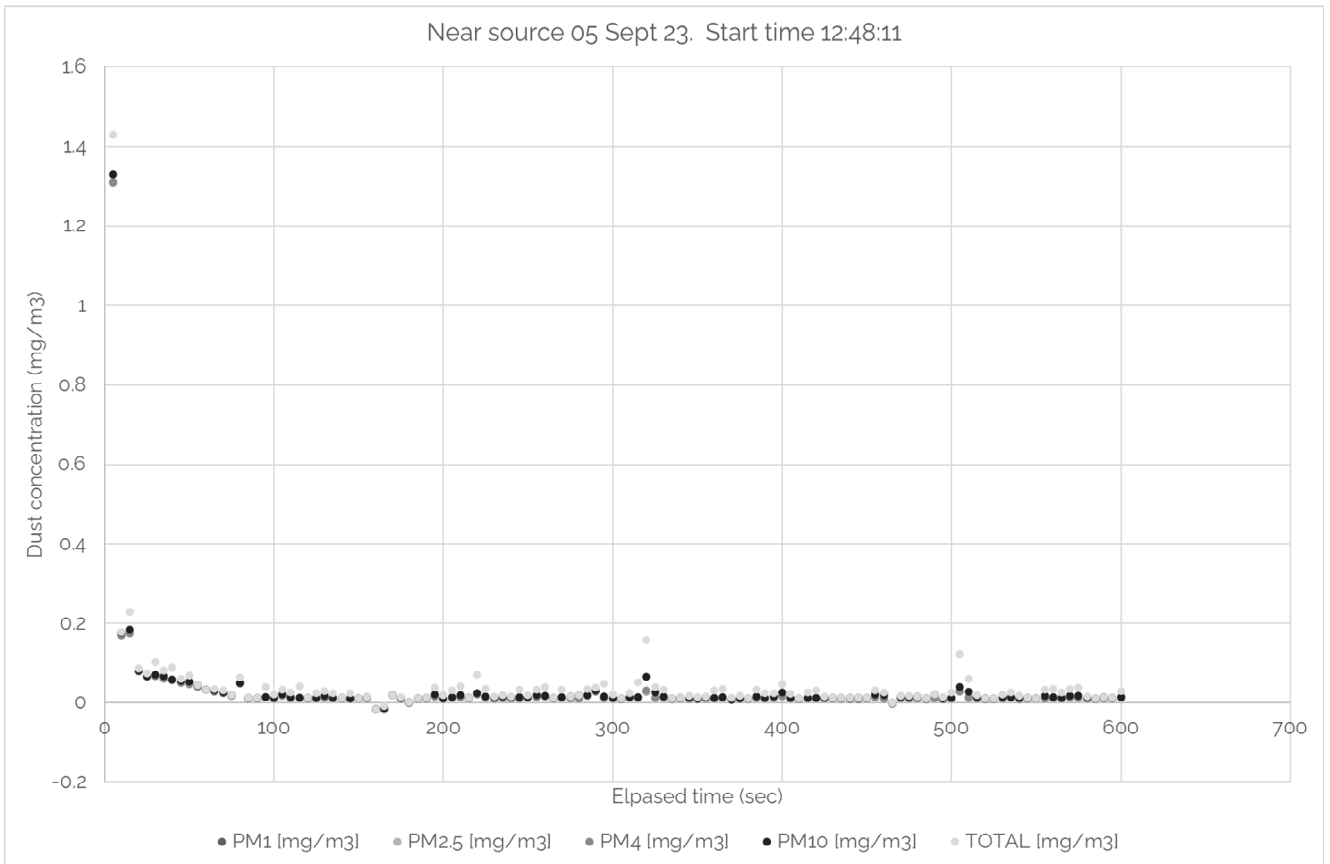

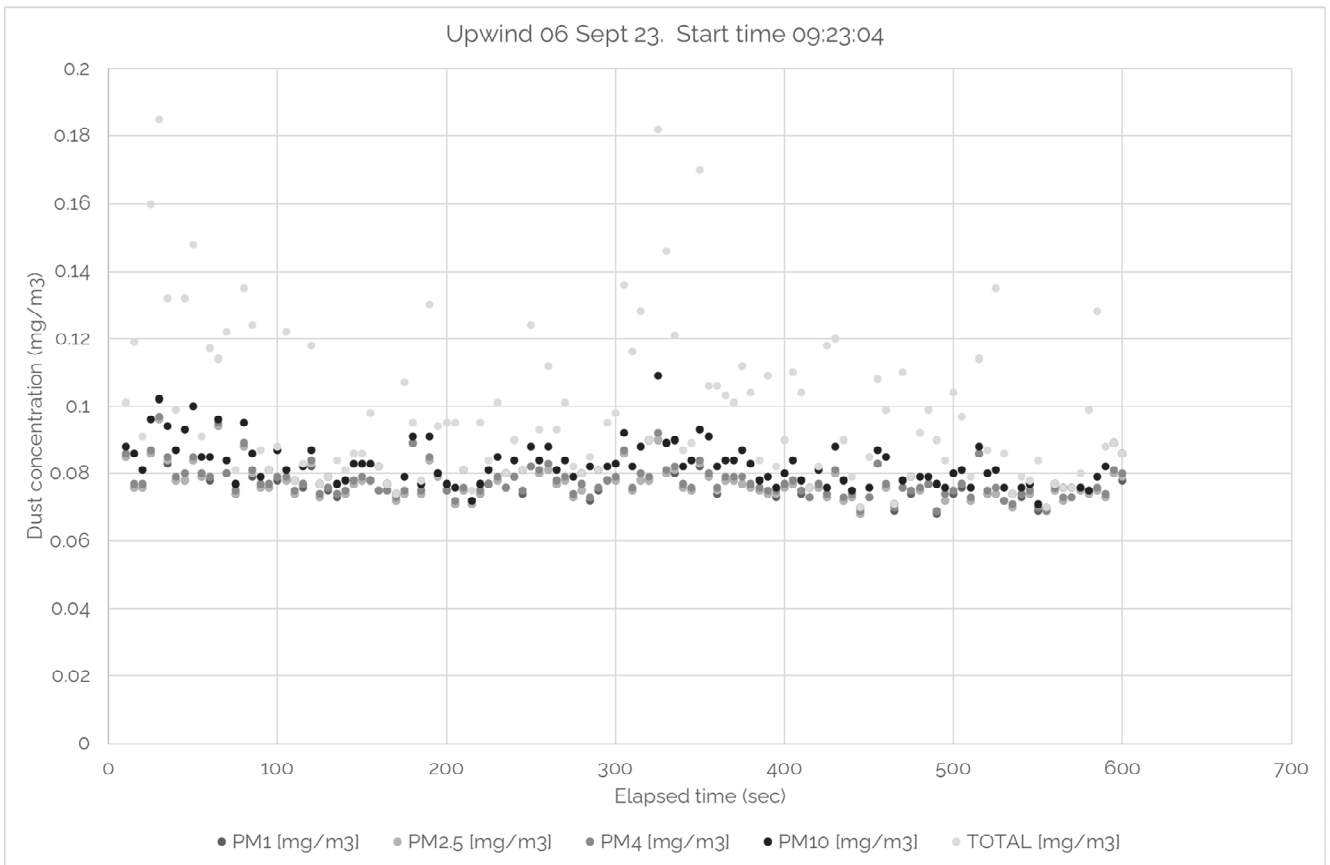
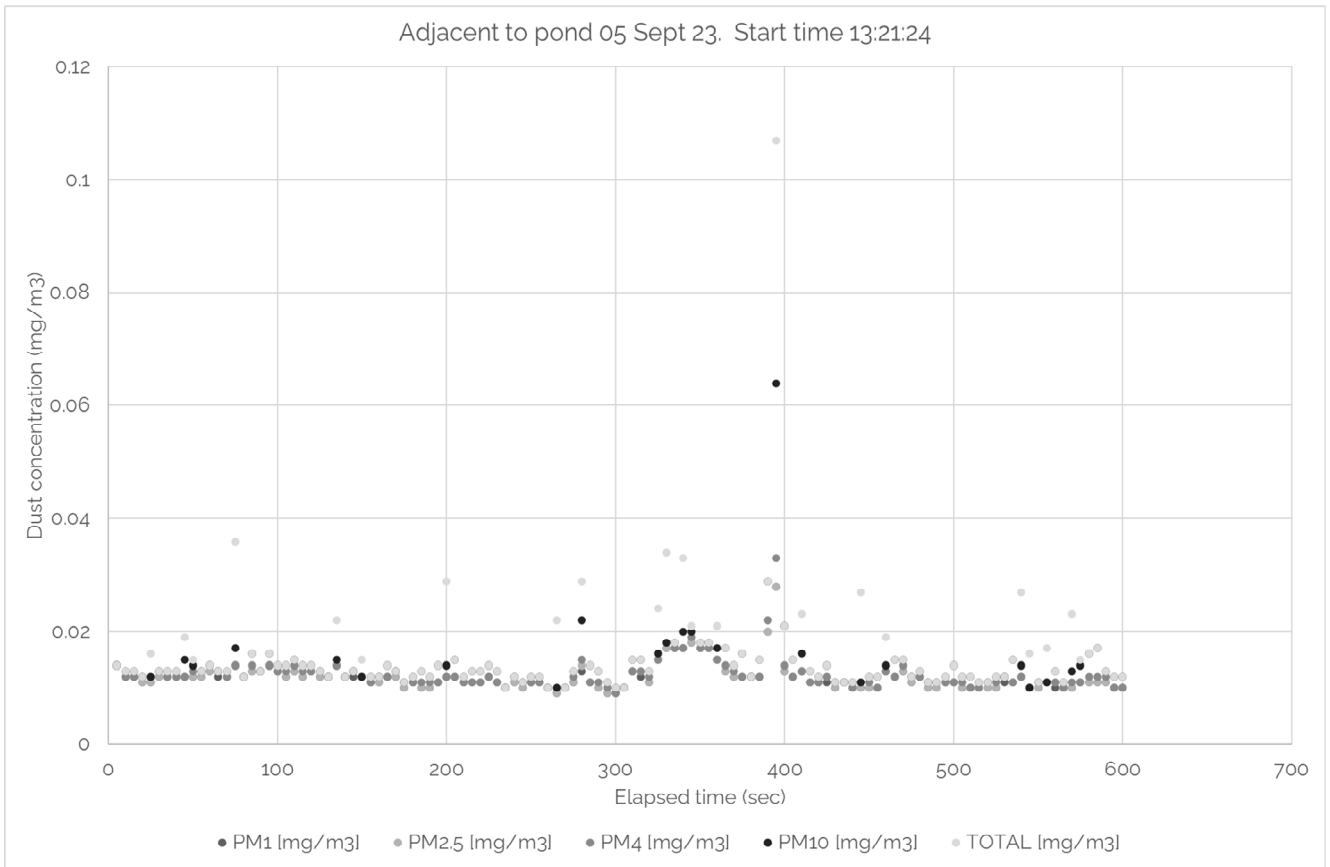

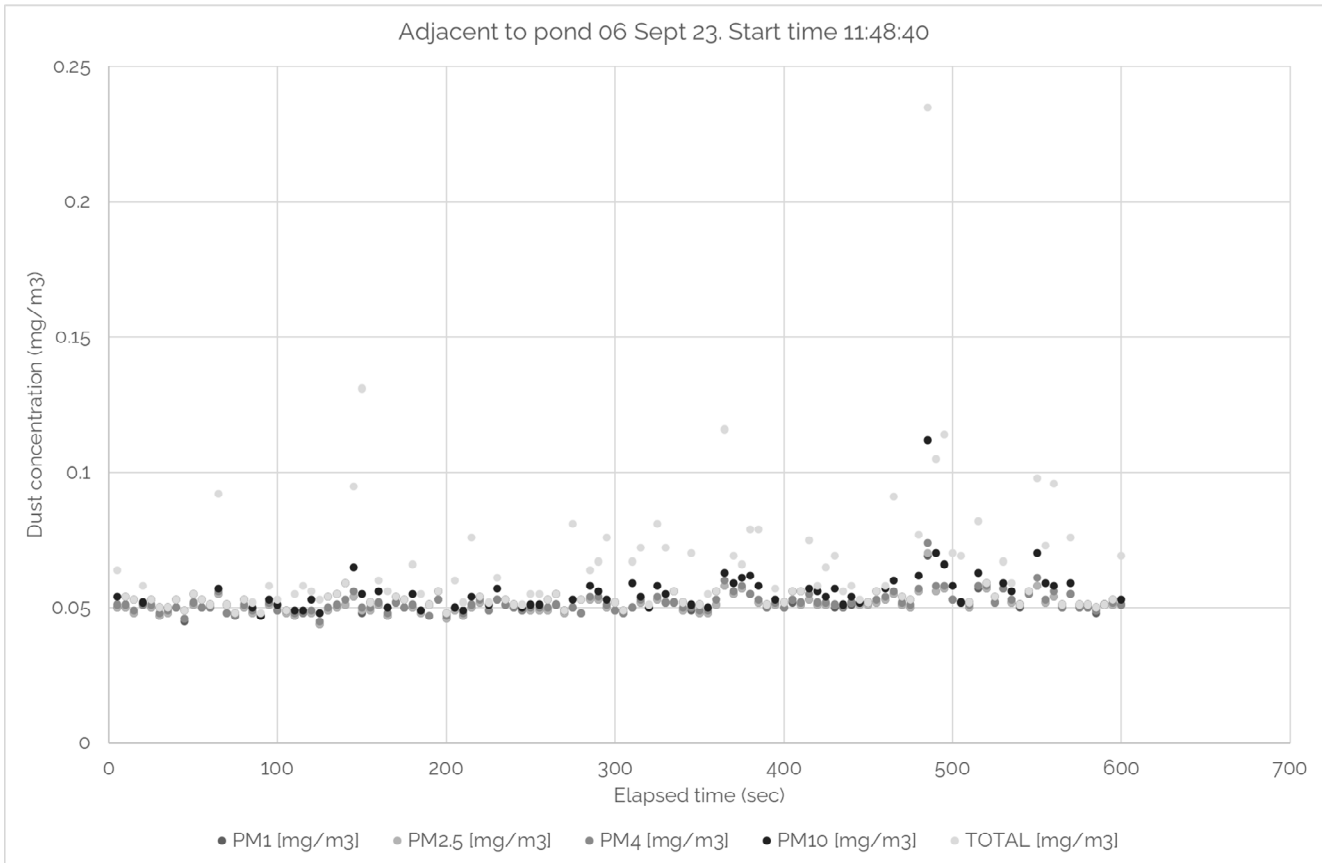
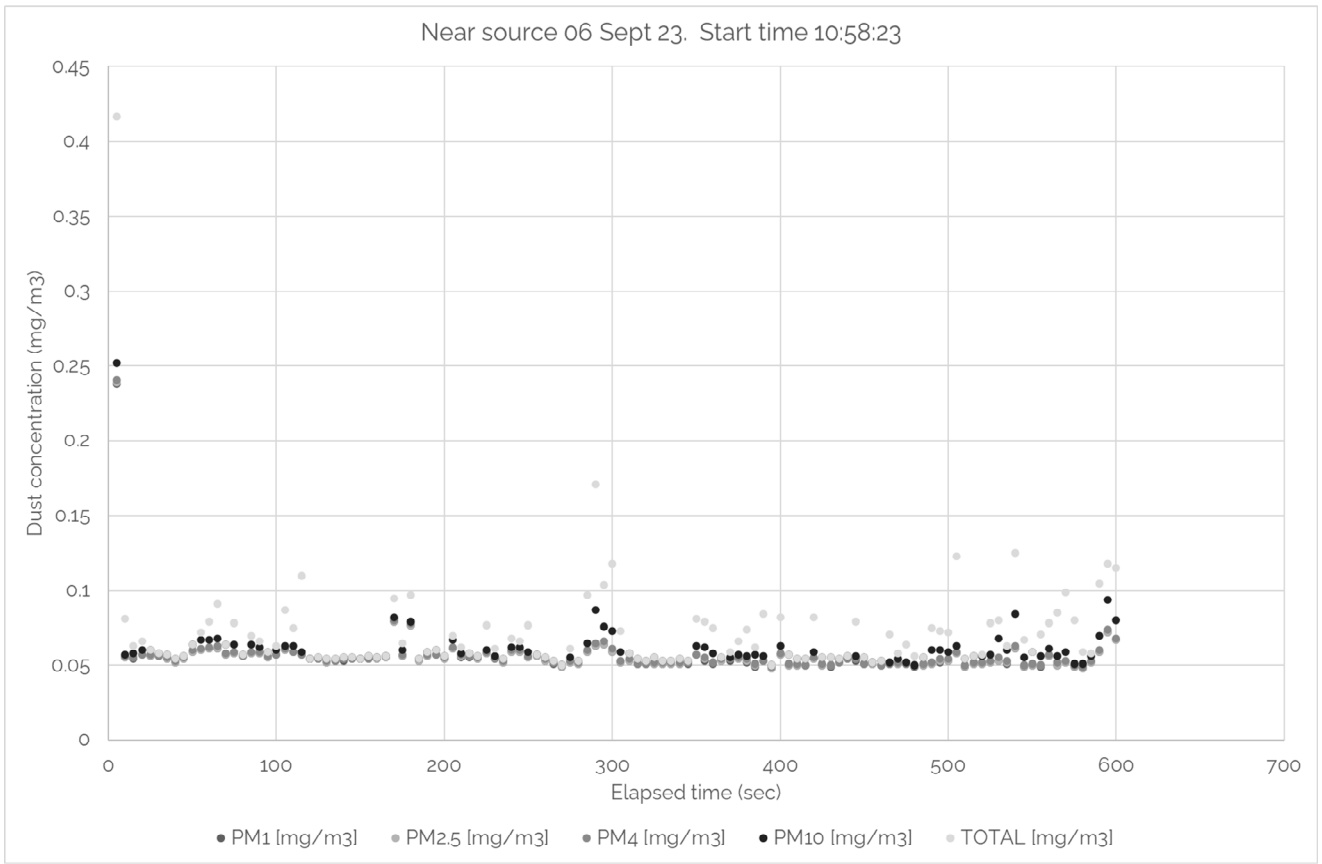

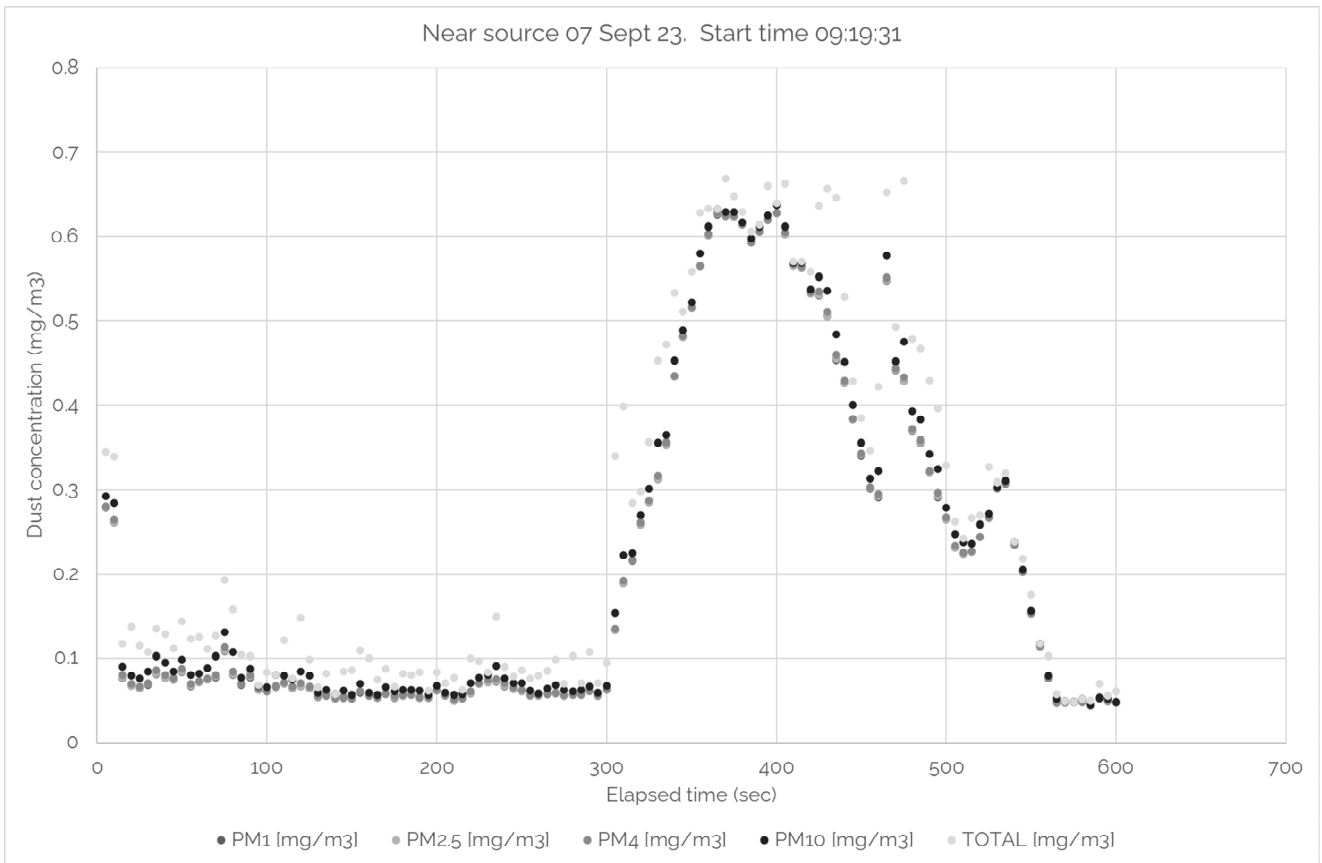
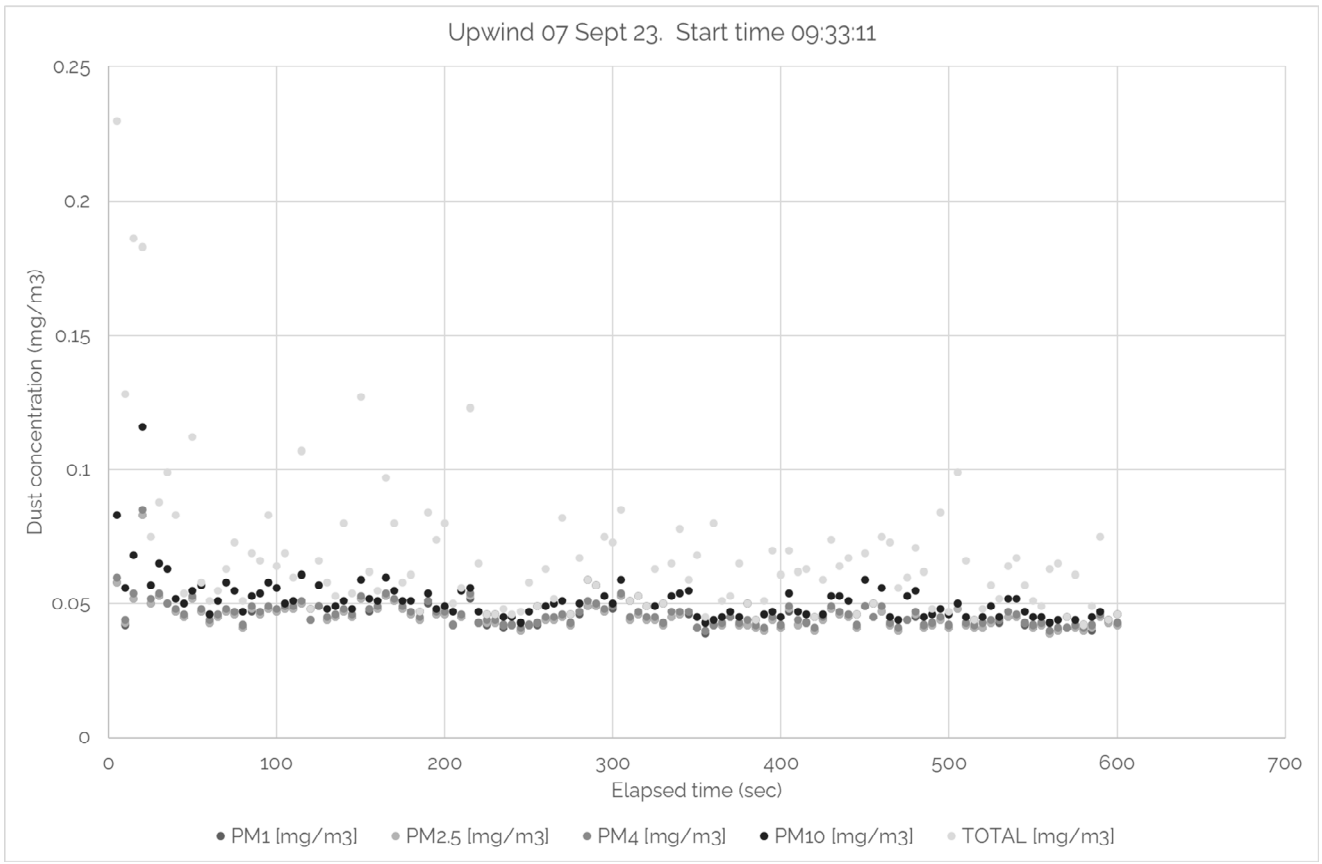

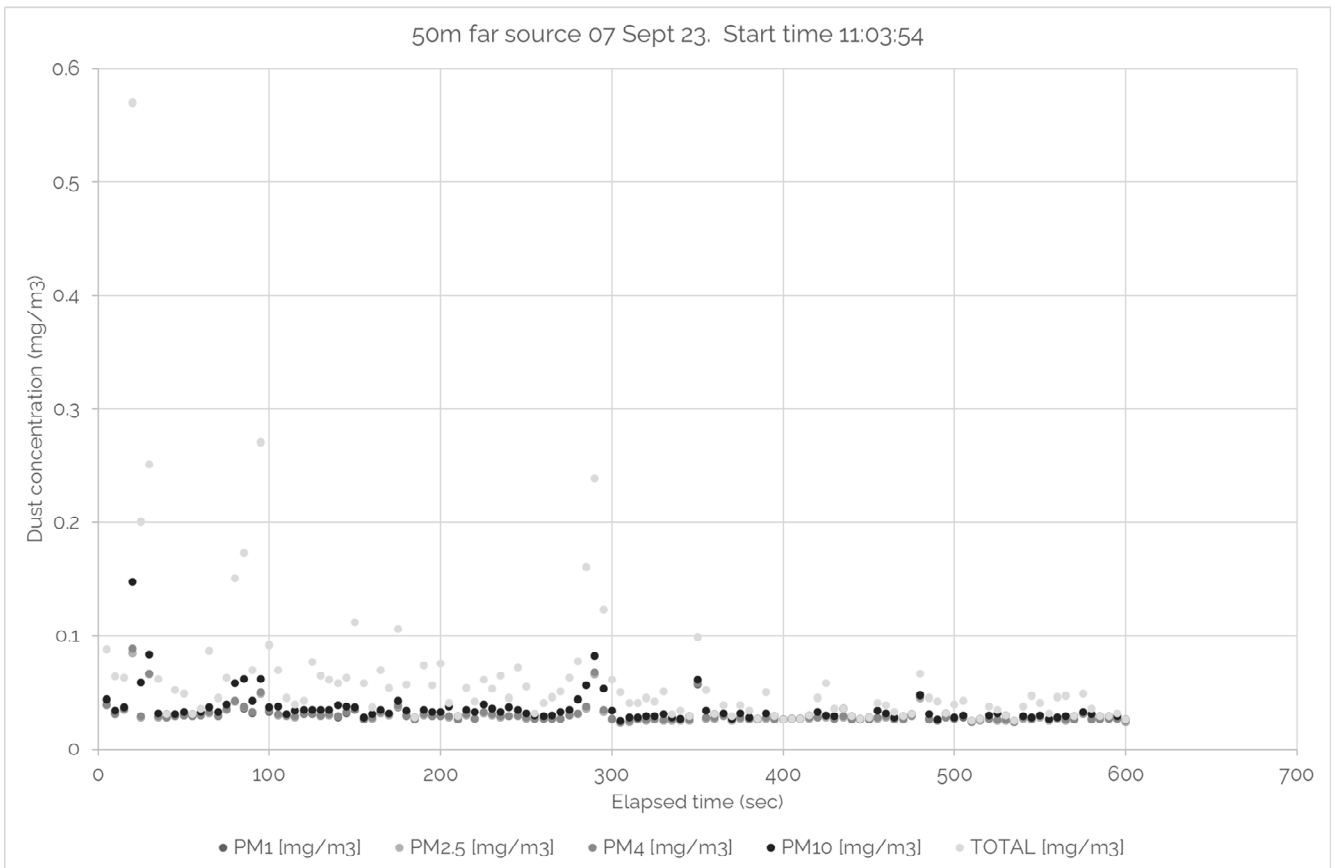
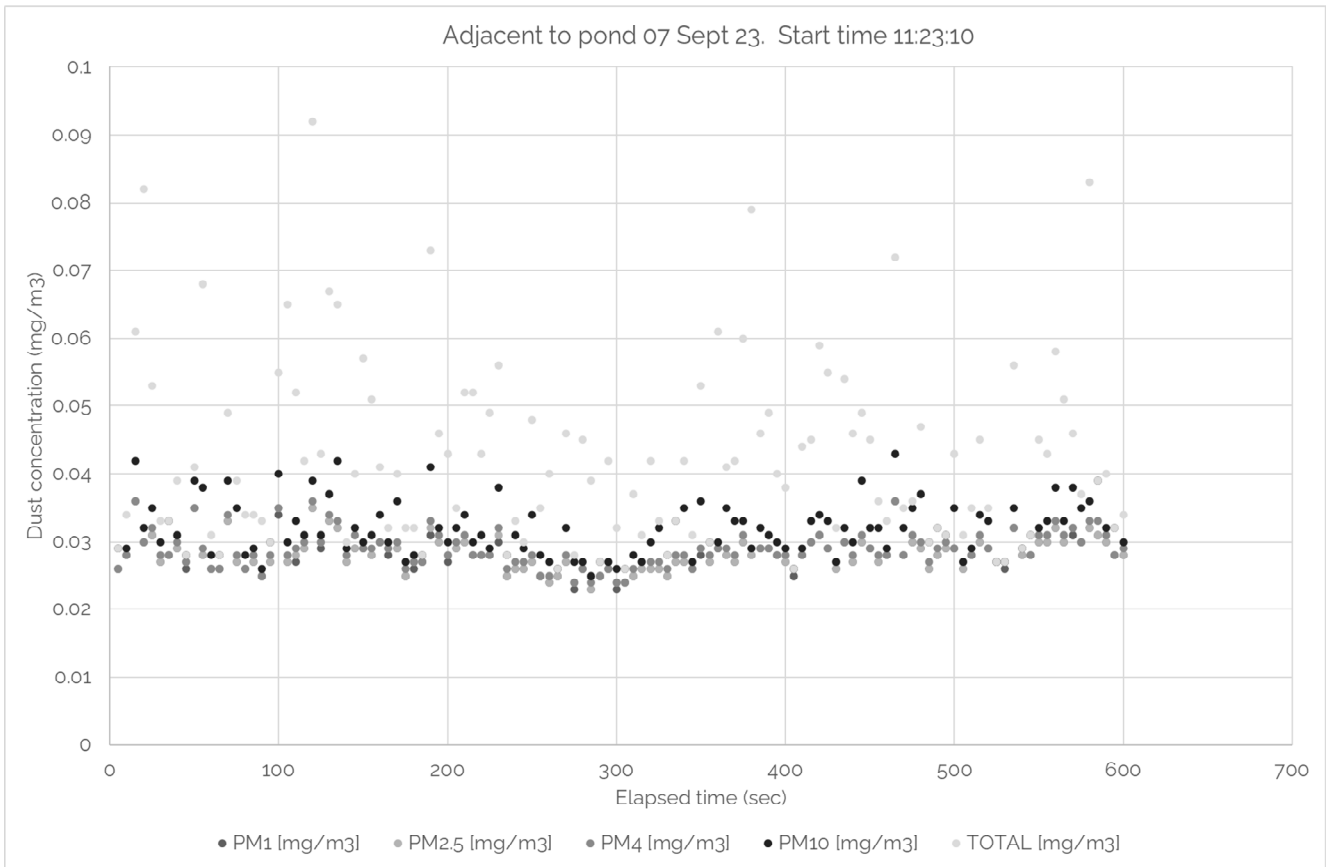

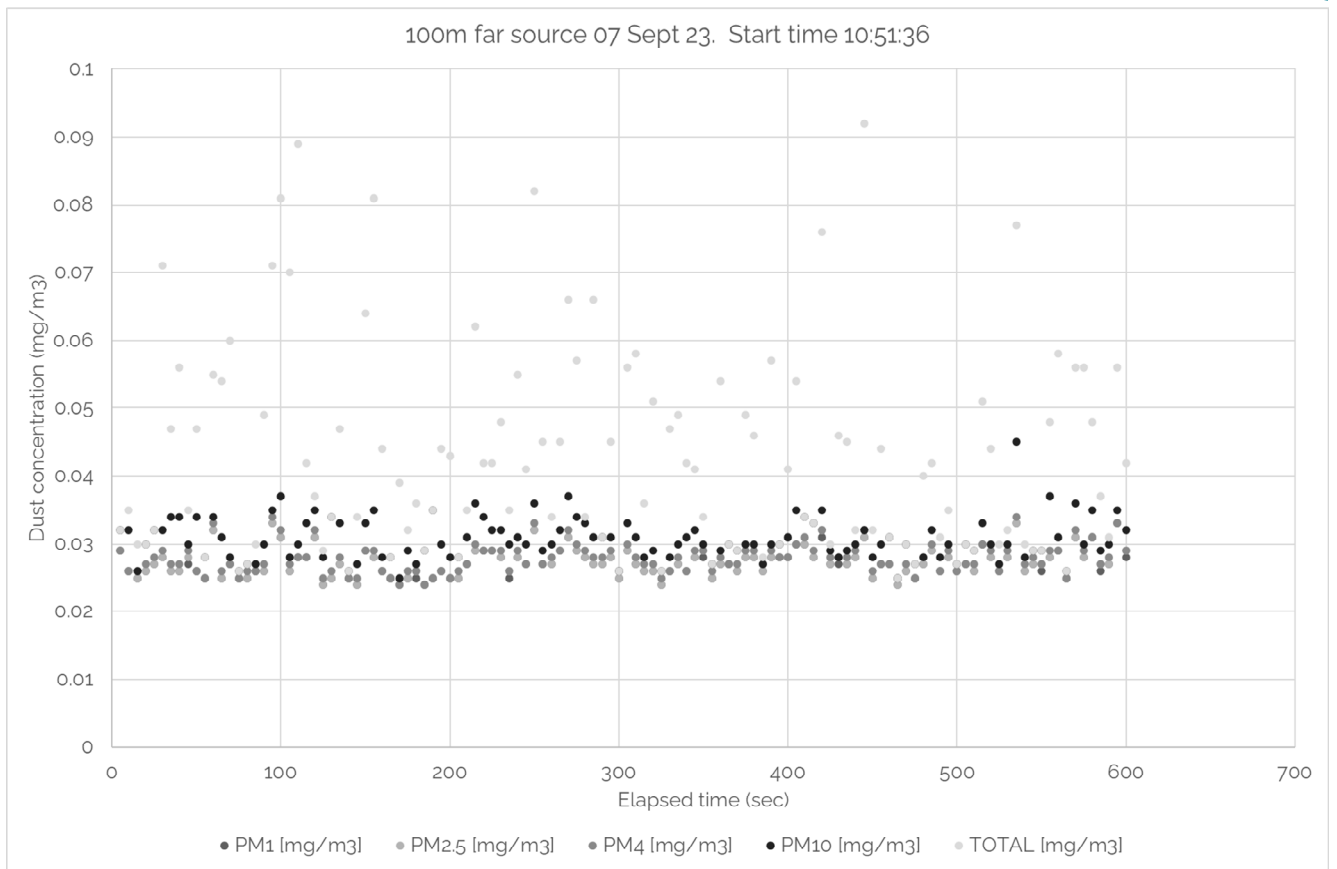

Appendix D Respirable fibres in dust calculations

Respirable fibres in dust calculations

Respirable fibres per mg of PM10 dust
 Respirable ('countable') fibre defined by HSG248 as >5µm in length, <3µm in width and with an aspect ratio >3:1

DETS assumption:

'The average fibre size is 20µm x 1µm (the average size measured by DETS in quantification samples). At this size, a sample requires 1.5million fibres /g to reach a level of 0.01 mass % contamination so, erring on the side of caution to account for smaller fibres, a figure of 1000000 fibres/g was chosen.'

DETS assumptions for fibre density are $3.3 \times 10^{-6} \mu\text{g}/\mu\text{m}^3$ for amphiboles and $2.5 \times 10^{-6} \mu\text{g}/\mu\text{m}^3$ for chrysotile

Fibre volume (assume a tube):

Diameter	1 µm
Length	20 µm
Volume	1.57E+01 µm ³

Asbestos density

3.30E-06 µg/µm ³
3.3E-12 g/µm ³
3300 kg/m ³

Asbestos density (ATSDR, 2001 - Table 4-2 Physical and Chemical Properties of Asbestos)

	Specific gravity	Density (kg/m ³)
Chrysotile	2.55	2550
Amosite	3.43	3430
Crocidolite	3.37	3370

Values also quoted in USGS, 2001. Asbestos: Geology, Mineralogy, Mining and Uses.

Concentration (wt/wt)

0.01 %

Number of fibres: 3000000 f/g

f/mg f/kg

30000 3.00E+10

Number of fibres

1.93E+06 f/g

Concentration (wt/wt): 1.56E-01 %

RIVM report 711701034 (2003)

'Assuming 2,000 to 40,000 fibres per ng of asbestos (Slooff and Blokzijl, 1987), a HUM-TOX SSCC in the range occurs in the range from 100 to 2,000 mgasbestos/kgsoil. The HUM TOX SSCC calculated with CSOIL is related to the MPR level of 100,000 fibre equivalents per m³ of air (annual average). In the soil this boils down to a content of 4.3×10^{-12} fibre equivalents per kg of earth. Conversion into a weight concentration gives a HUM-TOX SSCC of 100-2,000 mg/kgdw. The threshold value for respirable asbestos fibres in the soil must be related to the NR level of 1,000 fibre equivalents per m³ of air (annual average), since all respirable fibres in the soil are in principle available. In the soil this boils down to a content of 4.3×10^{-10} fibre equivalents per kg of earth. Conversion into a weight concentration gives a threshold value of 1-20 mg/kgdw.'

Equivalent density assuming average fibre dimensions above

2,000 f/ng	40,000 f/ng	
3.1831E-14	1.59155E-15	g/µm ³
31.83098862	1.591549431	kg/m ³

Concentration (wt/wt)

0.0015	0.000075 %
15	0.75 mg/kg

Number of fibres

3.00E+10	3.00E+10 f/kg
----------	---------------

Note: Fibre density appears to be too low using Sloof and Blokzijl values unless fibres are assumed to be extremely small Sloof and Blokzijl commented that:

'For the outside air in the Dutch situation, 1ng corresponds to 2000 to 40,000 fibers. Depending on the type and age of the fibers and the source, the ratio between the number of fibers determined by electron microscopy (EM) and light microscopy (LM) can vary considerably. For example, Cherrie et al. (1987) found an EM/LM ratio of 0.05 to 13 for the outside air for fibers with a length >5µm. Based on such findings it is not possible to provide a generally applicable conversion factor; this will differ per location.'
 For the above it is assumed that the lower fibre per gram estimate is more applicable to PCME results.

Estimation of airborne fibre concentration

Measured respirable fibres per gram respirable dust

3000000 f/g

Predicted/measured PM10 dust concentration

0.03 mg/m ³

Soil-derived dust fraction

100 %

Estimated airborne respirable asbestos fibre concentration

900 f/m ³

Appendix ESoBRA Excel spreadsheet exposure risk calculations

Calculation Sheet for risk from cumulative exposure to asbestos in air

Based on The quantitative risks of mesothelioma and lung cancer in relation to asbestos exposure, John T. Hodgson and Andrew Darnton, Ann Occup Hyg (2000) 44 (8): 565-601, and personal communication with Andrew Darnton and should be read in conjunction with SoBRA's Discussion Paper on Guidelines for Airborne Concentrations of Asbestos Fibres in Ambient Air: Implications for Quantitative Risk Assessment (SoBRA, 2021)
© SoBRA, 2021

Default parameters

Asbestos type	Amosite
Mesothelioma model	Linear
Lung cancer model	Non-Linear
Lung cancer base risk population	All - population average
Receptor expected lifetime	Lifetime 80 years
Lung cancer age adjustment	Age adjustment based on Latency

Concentration in air

Assumes exposure to constant average asbestos exposure

		Amosite		
Concentration in air	f/ml	5.00E-07	Equivalent to	0.5 f/m3

Exposure over five year tranches

Age	Concentration in air f/ml	Exposure			Exposure over each 5 year tranche (Includes adjustment to occupational years (equal to 2000hrs of exposure per year))		X - Cumulative exposure in f/ml.yr =Concentration in air x Exposure time hrs per year x Time period /2000 (hrs in an occupational year) to top of age group
		Days per year	Hours per day	Years (Actual)	Exposure time hrs per year hrs/year	f/ml.yr	
0							X - Cumulative exposure in f/ml.yr
1	5.00E-07	83	8	5	6.64E+02	8.30E-07	8.30E-07
2	5.00E-07	83	8	1	6.64E+02	1.66E-07	9.96E-07
3	5.00E-07				0.00E+00	0.00E+00	9.96E-07
4	5.00E-07				0.00E+00	0.00E+00	9.96E-07
5	5.00E-07				0.00E+00	0.00E+00	9.96E-07
6	5.00E-07				0.00E+00	0.00E+00	9.96E-07
7	5.00E-07				0.00E+00	0.00E+00	9.96E-07
8	5.00E-07				0.00E+00	0.00E+00	9.96E-07
9	5.00E-07				0.00E+00	0.00E+00	9.96E-07
10	5.00E-07				0.00E+00	0.00E+00	9.96E-07
11	5.00E-07				0.00E+00	0.00E+00	9.96E-07
12	5.00E-07				0.00E+00	0.00E+00	9.96E-07

Mesothelioma Risk

$$P_M = A_{pl}X^r + A_{pr}X^t$$

- P_M Percent excess mortality from Mesothelioma (in percent)
- A_{pl} Constant of proportionality for Pleural risk
- A_{pr} Constant of proportionality for peritoneal risk
- X Cumulative exposure in f/ml.yr
- r Pleural slope of exposure response (on a log-log scale)
- t Peritoneal slope of exposure response (on a log-log scale)

$$\hat{O}_M = \frac{(A_{pl}X^r + A_{pr}X^t)E_{adj}}{100}$$

- O_M the observed meso deaths
- E_{adj} the expected mortality from all causes adjusted to an age at start of exposure of 30.

Risk estimate based on a 30 year old worker exposed for a five year period with cumulative exposure above.
Reference: Developing risk estimates consistent with Table 11 for extended exposures, Hodgson and Darnton 2000

Best Estimate		
Asbestos type	Amosite	Reference
A_{pl}	0.1	H&D 2000 Table 1 Mesothelioma risk expressed as percentage total expected mortality per f/ml.yr - Adjusted for age at first exposure.
r_{meso}	1	Linear model
A_{pr}	0.0006	H&D 2000 Table 8 Best estimate slope (r=0.75, t=2.1)
t	2.1	H&D 2000 Table 8 Best estimate slope (r=0.75, t=2.1)
Expected mortality from all causes adjusted to an age at start of exposure of 30	0.7	H&D 2000 p. 584 "Absolute risk estimates can therefore be derived from the PM value for a given exposure by multiplying by a factor of 0.7."

Age	Age adjustment Factor for mesothelioma risk Lifetime 80 years	Reference	P_M (%)*	Risk	Risk age adjusted assuming Lifetime 80 years
0					
1	7	WATCH 2010 -2 Annex 3 - Contribution from a WATCH member following the February 2010 WATCH meeting (for 80 years). CIRIA C733 used for adjustment for ages 35+	8.3E-08	5.8E-10	4.1E-09
2	5.3		1.7E-08	1.2E-10	6.2E-10
3	4		0.0E+00	0.0E+00	0.0E+00
4	3		0.0E+00	0.0E+00	0.0E+00
5	2.1		0.0E+00	0.0E+00	0.0E+00
6	1.5		0.0E+00	0.0E+00	0.0E+00
7	1		0.0E+00	0.0E+00	0.0E+00
8	0.6		0.0E+00	0.0E+00	0.0E+00
9	0.4		0.0E+00	0.0E+00	0.0E+00
10	0.3		0.0E+00	0.0E+00	0.0E+00
11	0.2		0.0E+00	0.0E+00	0.0E+00
12	0.1		0.0E+00	0.0E+00	0.0E+00

* To get the contribution to the risk for the second period alone the risk due to the cumulative dose from the first period is subtracted... and so on.
Developing risk estimates consistent with Table 11 for extended periods, Hodgson and Darnton 2000

Cumulative risk	Amosite	Lifetime 80 years 4.7E-09
-----------------	---------	------------------------------

Lung Cancer

$$P_L = A_L X^r$$

P_L Percentage excess of expected lung cancer mortality
 A_L Constant of proportionality for lung cancer risk
 r Lung cancer slope of exposure response (on a log-log scale)
 X Cumulative exposure in f/ml.yr

$$\text{Predicted excess risk} = O_L - E_L = \frac{A_L X^r E_L}{100}$$

E_L Proportion of the specific population that will die of lung cancer between age 40-79

Risk estimate based on a 30 year old worker exposed for a five year period with cumulative exposure above.
 Reference: Developing risk estimates consistent with Table 11 for extended exposures, Hodgson and Darnton 2000

Best Estimate		
	Amosite	Reference
A_L	1.6	H&D 2000 Table 10 Best (r=1.3)
r_{lung}	1.3	H&D 2000 Table 10 Best (r=1.3)
Proportion of the specific population that will die of lung cancer between age 40-79	0.033	Based on Average 2016-2018 populations statistics

Age	Age adjustment	Age adjustment reference	P_L (%)	Risk (age adjusted)
0				
1	0-5	1	2.0E-08	6.5E-12
2	5-10	1	5.3E-09	1.7E-12
3	10-15	1	0.0E+00	0.0E+00
4	15-20	1	0.0E+00	0.0E+00
5	20-25	1	0.0E+00	0.0E+00
6	25-30	1	0.0E+00	0.0E+00
7	30-35	1	0.0E+00	0.0E+00
8	35-40	1	0.0E+00	0.0E+00
9	40-45	1	0.0E+00	0.0E+00
10	45-50	0.75	0.0E+00	0.0E+00
11	50-55	0.5	0.0E+00	0.0E+00
12	55-60	0.25	0.0E+00	0.0E+00

Developing risk estimates consistent with Table 11 for extended exposures, Hodgson and Darnton 2000

Cumulative risk	Amosite	8.3E-12
-----------------	---------	---------

Cumulative lifetime Risk Estimate

Asbestos type	Amosite		
Risk from Mesothelioma	Lifetime 80 years	Linear	4.7E-09
Risk from Lung Cancer	All - population average	Non-Linear	8.3E-12
TOTAL			4.7E-09

1 in ... risk

2.1E+08

Limitations

This spreadsheet is offered as a free available resource by SoBRA to improve the consistency in, and adoption of, the use of the Hodgson and Darnton algorithms for estimating lifetime cancer risk for low level environmental exposures to airborne asbestos fibres. It has been developed by members of the SoBRA Asbestos-in-soil sub-group acting in a voluntary capacity, and constitutes the work of the individual authors, not those of their employers. Users of this spreadsheet must satisfy themselves that the content is appropriate for the intended use and no guarantee of suitability is made.

Feedback on this spreadsheet is welcome and should be sent to info@sobra.org.uk

Calculation Sheet for risk from cumulative exposure to asbestos in air

Based on The quantitative risks of mesothelioma and lung cancer in relation to asbestos exposure, John T. Hodgson and Andrew Darnton, Ann Occup Hyg (2000) 44 (8): 565-601, and personal communication with Andrew Darnton and should be read in conjunction with SoBRA's Discussion Paper on Guidelines for Airborne Concentrations of Asbestos Fibres in Ambient Air: Implications for Quantitative Risk Assessment (SoBRA, 2021)
© SoBRA, 2021

Default parameters

Asbestos type	Amosite
Mesothelioma model	Linear
Lung cancer model	Non-Linear
Lung cancer base risk population	All - population average
Receptor expected lifetime	Lifetime 80 years
Lung cancer age adjustment	Age adjustment based on Latency

Concentration in air

Assumes exposure to constant average asbestos exposure

		Amosite		
Concentration in air	f/ml	5.00E-08	Equivalent to	0.05 f/m3

Exposure over five year tranches

Age	Concentration in air f/ml	Exposure			Exposure time hrs per year hrs/year	Exposure over each 5 year tranche (Includes adjustment to occupational years (equal to 2000hrs of exposure per year)) f/ml.yr	X - Cumulative exposure in f/ml.yr =Concentration in air x Exposure time hrs per year x Time period /2000 (hrs in an occupational year) to top of age group
		Days per year	Hours per day	Years (Actual)			
0							
1	5.00E-08	365	8	5	2.92E+03	3.65E-07	3.65E-07
2	5.00E-08	365	8	1	2.92E+03	7.30E-08	4.38E-07
3	5.00E-08				0.00E+00	0.00E+00	4.38E-07
4	5.00E-08				0.00E+00	0.00E+00	4.38E-07
5	5.00E-08				0.00E+00	0.00E+00	4.38E-07
6	5.00E-08				0.00E+00	0.00E+00	4.38E-07
7	5.00E-08				0.00E+00	0.00E+00	4.38E-07
8	5.00E-08				0.00E+00	0.00E+00	4.38E-07
9	5.00E-08				0.00E+00	0.00E+00	4.38E-07
10	5.00E-08				0.00E+00	0.00E+00	4.38E-07
11	5.00E-08				0.00E+00	0.00E+00	4.38E-07
12	5.00E-08				0.00E+00	0.00E+00	4.38E-07

Mesothelioma Risk

$$P_M = A_{pl}X^r + A_{pr}X^t$$

- P_M Percent excess mortality from Mesothelioma (in percent)
- A_{pl} Constant of proportionality for Pleural risk
- A_{pr} Constant of proportionality for peritoneal risk
- X Cumulative exposure in f/ml.yr
- r Pleural slope of exposure response (on a log-log scale)
- t Peritoneal slope of exposure response (on a log-log scale)

$$\hat{O}_M = \frac{(A_{pl}X^r + A_{pr}X^t)E_{Adj}}{100}$$

- O_M the observed meso deaths
- E_{Adj} the expected mortality from all causes adjusted to an age at start of exposure of 30.

Risk estimate based on a 30 year old worker exposed for a five year period with cumulative exposure above.
Reference: Developing risk estimates consistent with Table 11 for extended exposures, Hodgson and Darnton 2000

Best Estimate		
Asbestos type	Amosite	Reference
A_{pl}	0.1	H&D 2000 Table 1 Mesothelioma risk expressed as percentage total expected mortality per f/ml.yr - Adjusted for age at first exposure.
r_{meso}	1	Linear model
A_{pr}	0.0006	H&D 2000 Table 8 Best estimate slope (r=0.75, t=2.1)
t	2.1	H&D 2000 Table 8 Best estimate slope (r=0.75, t=2.1)
Expected mortality from all causes adjusted to an age at start of exposure of 30	0.7	H&D 2000 p. 584 "Absolute risk estimates can therefore be derived from the PM value for a given exposure by multiplying by a factor of 0.7."

Age	Age adjustment Factor for mesothelioma risk Lifetime 80 years	Reference	P_M (%)*	Risk	Risk age adjusted assuming Lifetime 80 years
0					
1	7	WATCH 2010 -2 Annex 3 - Contribution from a WATCH member following the February 2010 WATCH meeting (for 80 years). CIRIA C733 used for adjustment for ages 35+	3.7E-08	2.6E-10	1.8E-09
2	5.3		7.3E-09	5.1E-11	2.7E-10
3	4		0.0E+00	0.0E+00	0.0E+00
4	3		0.0E+00	0.0E+00	0.0E+00
5	2.1		0.0E+00	0.0E+00	0.0E+00
6	1.5		0.0E+00	0.0E+00	0.0E+00
7	1		0.0E+00	0.0E+00	0.0E+00
8	0.6		0.0E+00	0.0E+00	0.0E+00
9	0.4		0.0E+00	0.0E+00	0.0E+00
10	0.3		0.0E+00	0.0E+00	0.0E+00
11	0.2		0.0E+00	0.0E+00	0.0E+00
12	0.1		0.0E+00	0.0E+00	0.0E+00

* To get the contribution to the risk for the second period alone the risk due to the cumulative dose from the first period is subtracted... and so on.
Developing risk estimates consistent with Table 11 for extended periods, Hodgson and Darnton 2000

Cumulative risk	Amosite	Lifetime 80 years 2.1E-09
-----------------	---------	------------------------------

Lung Cancer

$$P_L = A_L X^r$$

P_L Percentage excess of expected lung cancer mortality
 A_L Constant of proportionality for lung cancer risk
 r Lung cancer slope of exposure response (on a log-log scale)
 X Cumulative exposure in f/ml.yr

$$\text{Predicted excess risk} = O_L - E_L = \frac{A_L X^r E_L}{100}$$

E_L Proportion of the specific population that will die of lung cancer between age 40-79

Risk estimate based on a 30 year old worker exposed for a five year period with cumulative exposure above.
 Reference: Developing risk estimates consistent with Table 11 for extended exposures, Hodgson and Darnton 2000

Best Estimate		
	Amosite	Reference
A_L	1.6	H&D 2000 Table 10 Best (r=1.3)
r_{lung}	1.3	H&D 2000 Table 10 Best (r=1.3)
Proportion of the specific population that will die of lung cancer between age 40-79	0.033	Based on Average 2016-2018 populations statistics

Age	Age adjustment	Age adjustment reference	P_L (%)	Risk (age adjusted)
0				
1	0-5	1	6.8E-09	2.2E-12
2	5-10	1	1.8E-09	6.0E-13
3	10-15	1	0.0E+00	0.0E+00
4	15-20	1	0.0E+00	0.0E+00
5	20-25	1	0.0E+00	0.0E+00
6	25-30	1	0.0E+00	0.0E+00
7	30-35	1	0.0E+00	0.0E+00
8	35-40	1	0.0E+00	0.0E+00
9	40-45	1	0.0E+00	0.0E+00
10	45-50	0.75	0.0E+00	0.0E+00
11	50-55	0.5	0.0E+00	0.0E+00
12	55-60	0.25	0.0E+00	0.0E+00

Developing risk estimates consistent with Table 11 for extended exposures, Hodgson and Darnton 2000

Cumulative risk	Amosite	2.8E-12
-----------------	---------	---------

Cumulative lifetime Risk Estimate

Asbestos type	Amosite		
Risk from Mesothelioma	Lifetime 80 years	Linear	2.1E-09
Risk from Lung Cancer	All - population average	Non-Linear	2.8E-12
TOTAL			2.1E-09

1 in ... risk

4.8E+08

Limitations

This spreadsheet is offered as a free available resource by SoBRA to improve the consistency in, and adoption of, the use of the Hodgson and Darnton algorithms for estimating lifetime cancer risk for low level environmental exposures to airborne asbestos fibres. It has been developed by members of the SoBRA Asbestos-in-soil sub-group acting in a voluntary capacity, and constitutes the work of the individual authors, not those of their employers. Users of this spreadsheet must satisfy themselves that the content is appropriate for the intended use and no guarantee of suitability is made.

Feedback on this spreadsheet is welcome and should be sent to info@sobra.org.uk

Appendix F Factual summary of data provided by Provectus or directly acquired by Hydrock

Provectus data pertaining to Maw Green

The data provided to me, in summary, is:

- » Excel summary table of activity-based monitoring results for monitoring at MG STF carried out between 15 August 2022 and 15 September 2023
- » Individual certificates of analysis issued by IOM for the sample testing summarised in the table noted above
- » Individual certificates of analysis issued by IOM for the sample testing summarised in the table noted above for which SEM analysis was carried out
- » Pre-treatment soil reception testing analytical certificates for MG STF issued by Eurofins for sampling undertaken by Provectus between 17 August 2022 and 06 October 2023
- » Post-treatment soil validation testing for MG STF, and accompanying Provectus soil validation reports for the period 15 August 2022 to 19 October 2023
- » Automated ambient dust monitoring data from MG STF carried out between 12 July and 06 September 2023
- » Laboratory certificates issued by Eurofins for the analysis of asbestos fibres in water samples taken from the surface water treatment plant at MG STF from 07 September 2023 to 21 September 2023



Figure F.1: Google Earth image of STF and asbestos soil treatment area for context

Activity-based sampling (air)

Air monitoring of the operational STF activities has been carried out at MG (typically daily) between 15 August 2022 and 15 September 2023. The monitoring has either been carried out by Provectus, or on behalf of Provectus by Thames Laboratories,

Sample filters have been analysed by IOM using SEM to achieve a LOD of 0.0005f/ml throughout this period with the exception of 09 November 2022 to 18 November 2022. In addition, separate sample filters have been analysed by Thames by PCOM during the periods 09 November 2022 to 18 November 2022, and 09 February 2023 to 15 September 2023. Between 07 September 2022 and 27 January 2023 sampling was undertaken at three locations within the STF. From 03 April 2023 onwards the monitoring is limited to one location next to the screener.

The individual monitoring locations are indicated in the sample location diagrams provided on the monitoring certificates issued by Thames.

Table F.1: Summary details of air monitoring at Maw Green

Monitoring Parameter	Value/Details	
	PCOM analysis	SEM analysis
Pump sampling rate	Pump use varies from 1 to 2 (with the latter samples are pooled) 2-16 litres per minute	Pump use varies from 1 to 2 (with the latter samples are pooled) 12-16 litres per minute
Sample duration	Typically 60 minutes (at 8 litres per minute)	2 hours for sampling undertaken by Provectus (at 12 litres per minute). 90 minutes for sampling undertaken by Thames (at 16 litres per minute)
Number of sampling points	3	3 (up until 03 April 2023)
Sample volume achieved	1440 litres for the period 09 November 2022 to 18 November 2022 480-992 litres for the period 09 February 2023 to 15 September 2023	Typically 1440 litres (maximum 1856 litres)
Weather conditions at time of sampling	Not reported by Riverside/Thames by data available from landfill weather station	
Analytical method	PCOM – carried out by Riverside/Thames	SEM – carried out by Institute of Occupational Medicine (IOM)
Limit of quantification achieved	0.003-0.01f/ml	0.0005f/ml
Reported concentrations	<LOQ	Typically <0.0005f/ml (maximum of 9 fibres equating to a concentration of 0.0015f/ml)

Example site plan

Works/Sample Location Diagram

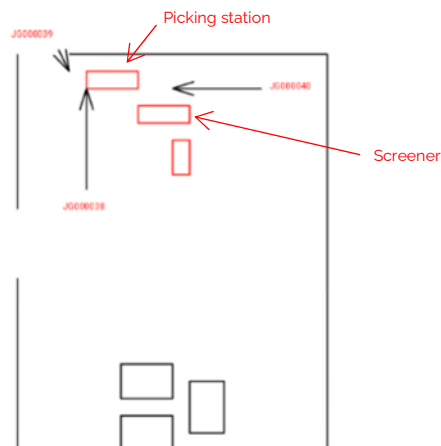

Additional comments

The activity-based air monitoring has been undertaken with the only dust suppression measure used being the damping down of the concrete hardstanding. There is no equivalent monitoring for when further dust suppression measures were active (e.g. air misters and sprayers).

The SEM dataset from Provectus/Thames/IOM monitoring and analysis for MG can be presented as follows:

Table F.2: Summary details of SEM air monitoring results for Maw Green

Parameter	Value
Total number of air samples	395
Number of samples with zero fibres reported	339
Number of samples with countable fibres present	56
Percent of samples with countable fibres	14.2%
95 th percentile fibre count	1
99 th percentile fibre count	3
Maximum fibre count	9
Maximum concentration (total)	0.0015f/ml
Maximum concentration (amosite)	0.0013f/ml
Maximum concentration (chrysotile)	<0.0005f/ml
Percent of samples with concentration >LOQ	1.8%

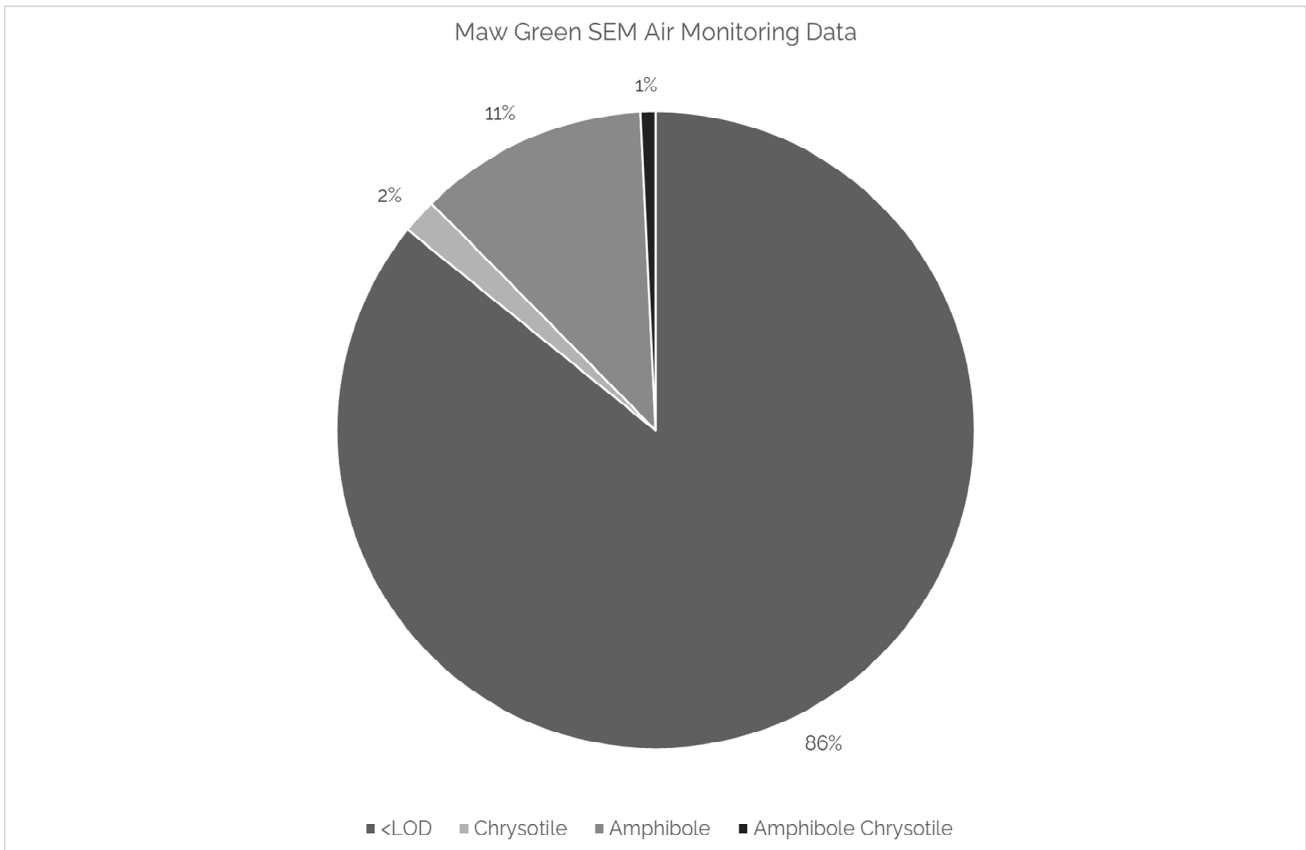

Figure F.2: Percentage detection of asbestos types in Maw Green SEM air monitoring results

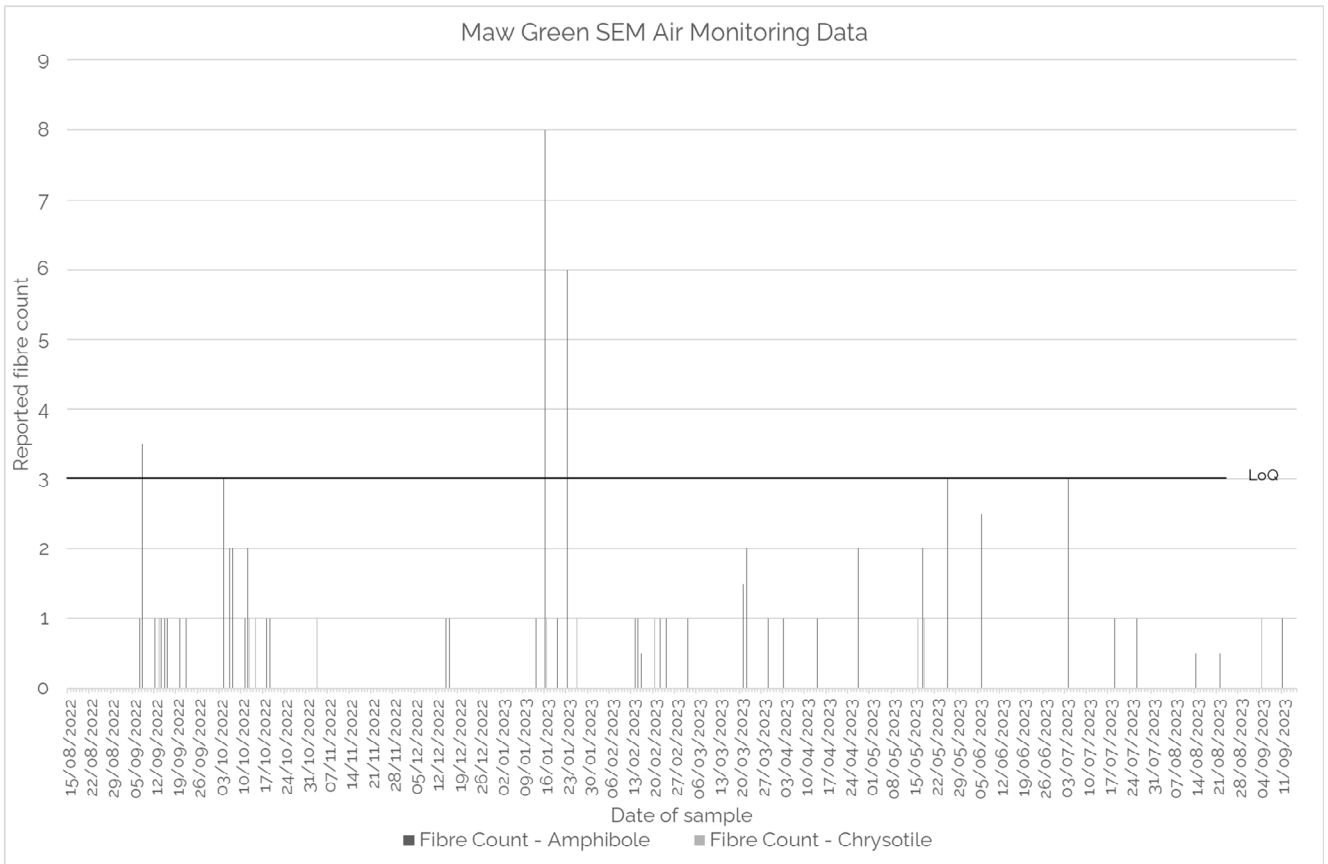

Figure F.3: SEM fibre count results for Maw Green air monitoring

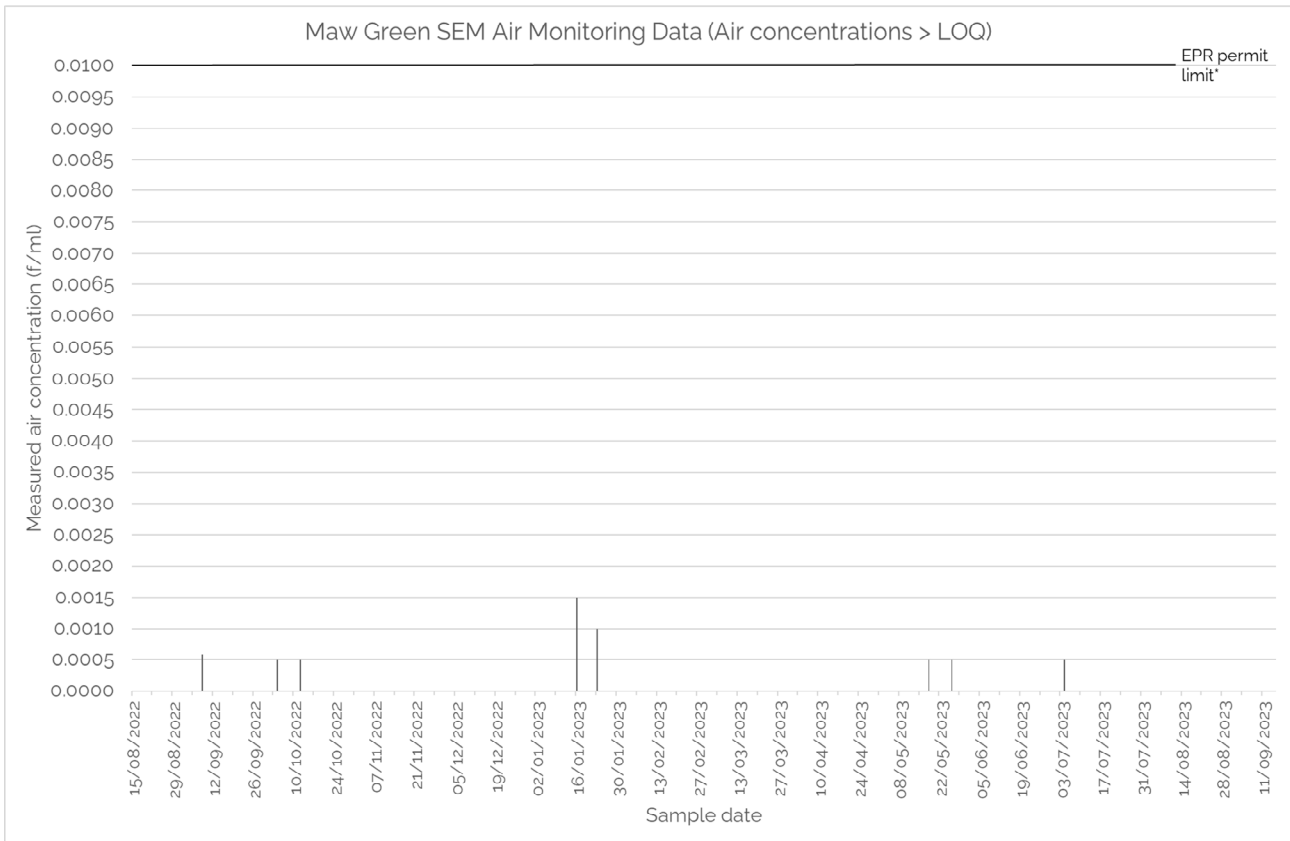

Figure F.4: SEM asbestos fibre air concentrations for Maw Green air monitoring

* Note the EPR permit limit illustrated in Figure F.4 is defined as a PCOM concentration, whereas the measured concentrations are SEM measurements. Correcting for the unit difference would result in either a reduction in the illustrated measured concentrations or an increase in the illustrated permit limit.

An example location for the air monitoring at MG is shown in the photograph below taken on 08 June 2023.



Figure F.5: Example location for SEM air monitoring at Maw Green

Pre-processed acceptance soil test data

Sample analysis laboratory certificates issued by Chemtest/Eurofins Chemtest for samples of pre-processed soils for the period of 17 August 2022 to 06 October 2023 have been provided to me.

This data comprises asbestos gravimetric analysis test data for pre-processed soil from 28 different sites of origin sampled over the period 15 August 2022 – 06 October 2023. The sampling protocol utilised by Provectus for this is as follows:

Table F.3: Provectus sampling frequencies

Volume of soil (t)	No. of samples needed (before or during acceptance at STF)
< 100	1
100 - 500	2
500 +	2 + 1 for every 500t

The dataset can be described and presented as follows:

Table F.4: Summary details of pre-processed acceptance soil test results for Maw Green

Parameter	Value
Total number of soil samples	118
Number of samples with no asbestos detected	69
Number of samples with detectable asbestos present	49
Number of samples with asbestos concentration > LOQ	40
Median concentration	<0.001%wt/wt
Upper quartile	0.002%wt/wt
90th percentile concentration	0.008%wt/wt
95th percentile concentration	0.019%wt/wt
Maximum concentration	0.5%wt/wt (repeat sample 0.018%wt/wt)

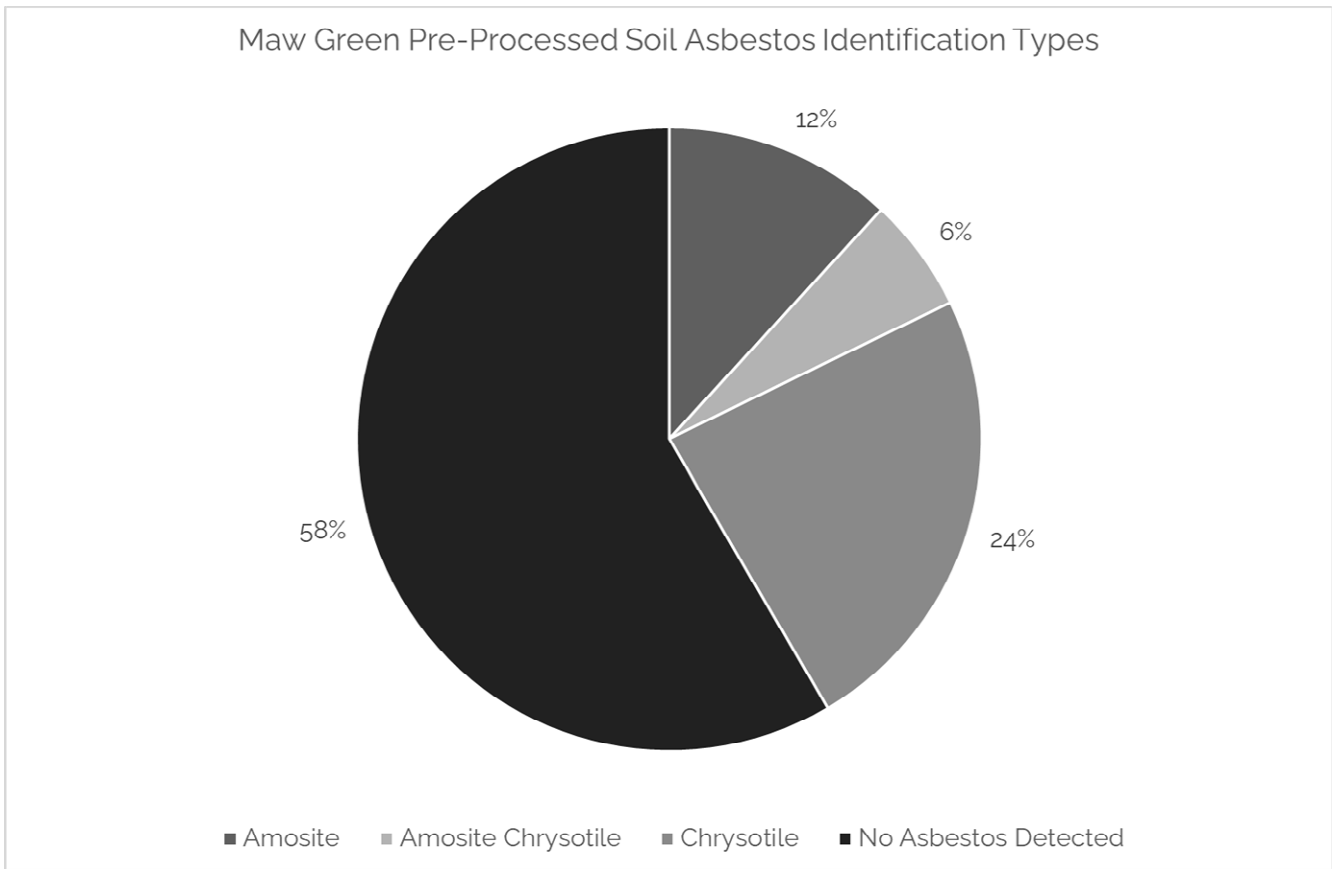

Figure F.6: Percentage detection of asbestos types in Maw Green pre-processed soil sample results

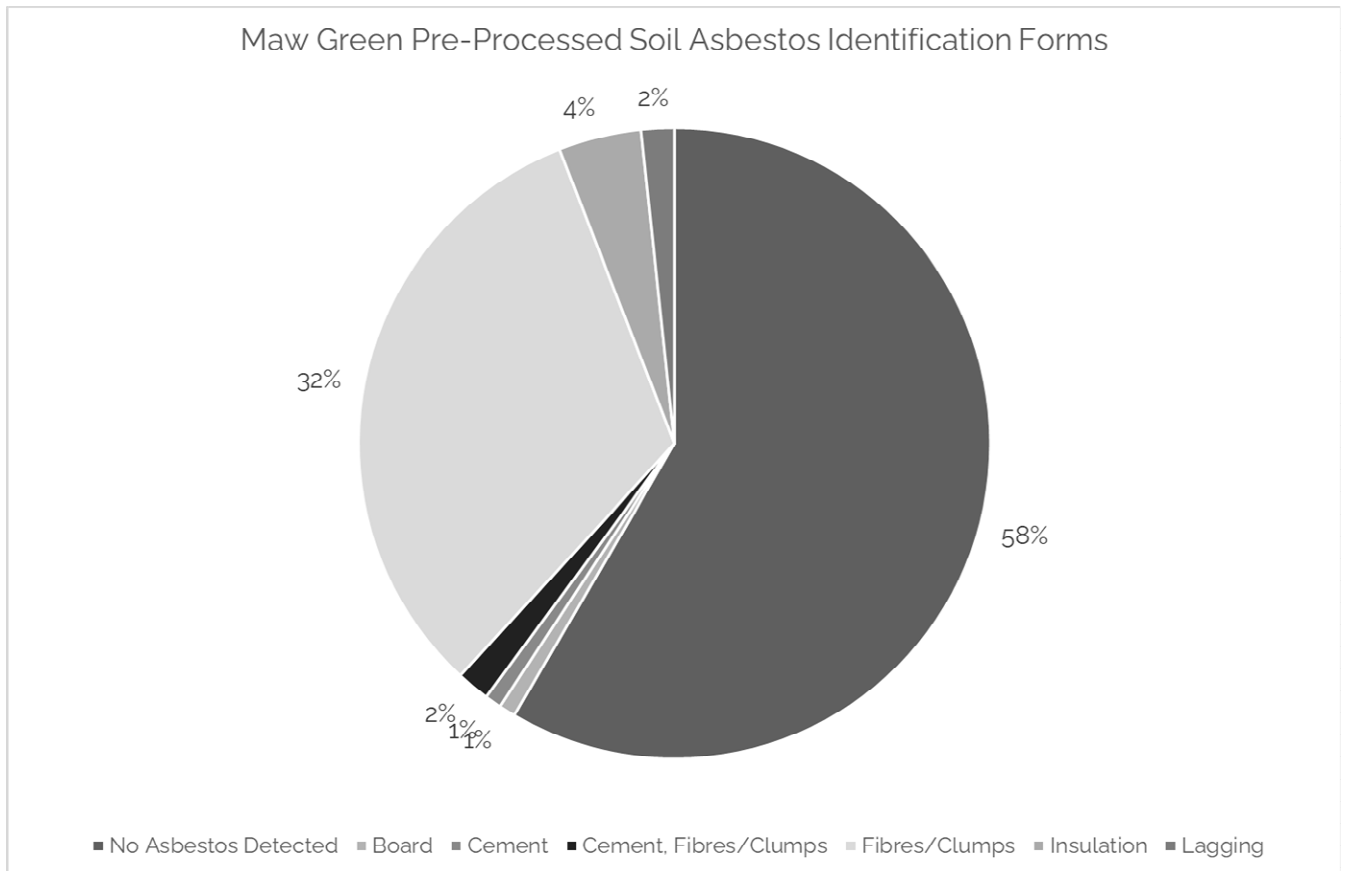

Figure F.7: Percentage detection of asbestos forms in Maw Green pre-processed soil sample results

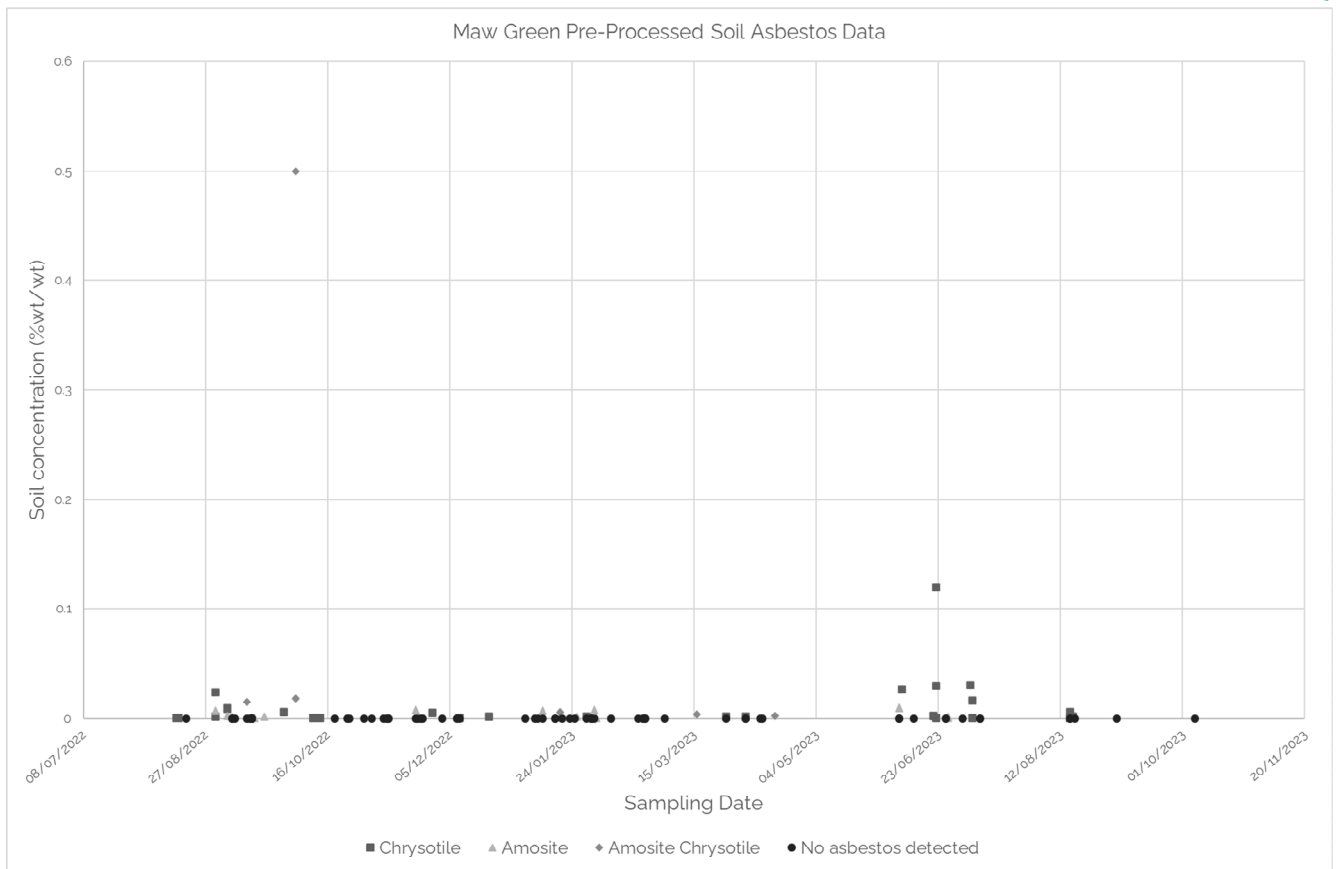

Figure F.8: Pre-processed soil asbestos concentrations for Maw Green

Table F.5: Summary details of pre-processed soil moisture results for Maw Green

Parameter	Value
Total number of soil samples	118
Minimum	4.3%
Maximum	30%
5th percentile	7.7%
Lower quartile	9.4%

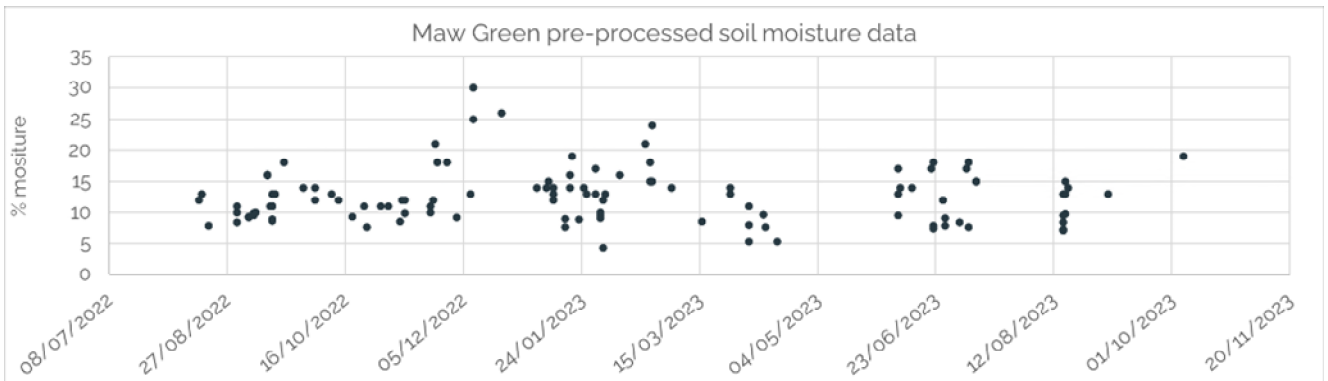

Figure F.9: Pre-processed soil moisture results for Maw Green

Post-processed soil validation data

This data comprises asbestos gravimetric analysis test data for post-processed soil from 28 different sites of origin sampled over the period 15 August 2022 – 19 October 2023. The dataset relates to the finer fraction of processed soil from the 3-way screener, and can be presented as follows:

Table F.6: Summary of post-processed soil sites of origin and processed amounts for Maw Green

Number of Input Material Projects (i.e. sites of origin)	Total Material Validated (t)	Average Batch Size (t)
28 (received tonnage from sites varies considerably)	38,130	2,542

Table F.7: Summary details of post-processed validation soil test results for Maw Green

Parameter	Value
Total number of soil samples	89
Number of samples with no asbestos detected	43
Number of samples with detectable asbestos present	46
Number of samples with asbestos concentration > LOQ	27
Median concentration	<LOQ
90th percentile concentration	0.008%wt/wt
95th percentile concentration	0.02%wt/wt
Maximum concentration	0.075%wt/wt

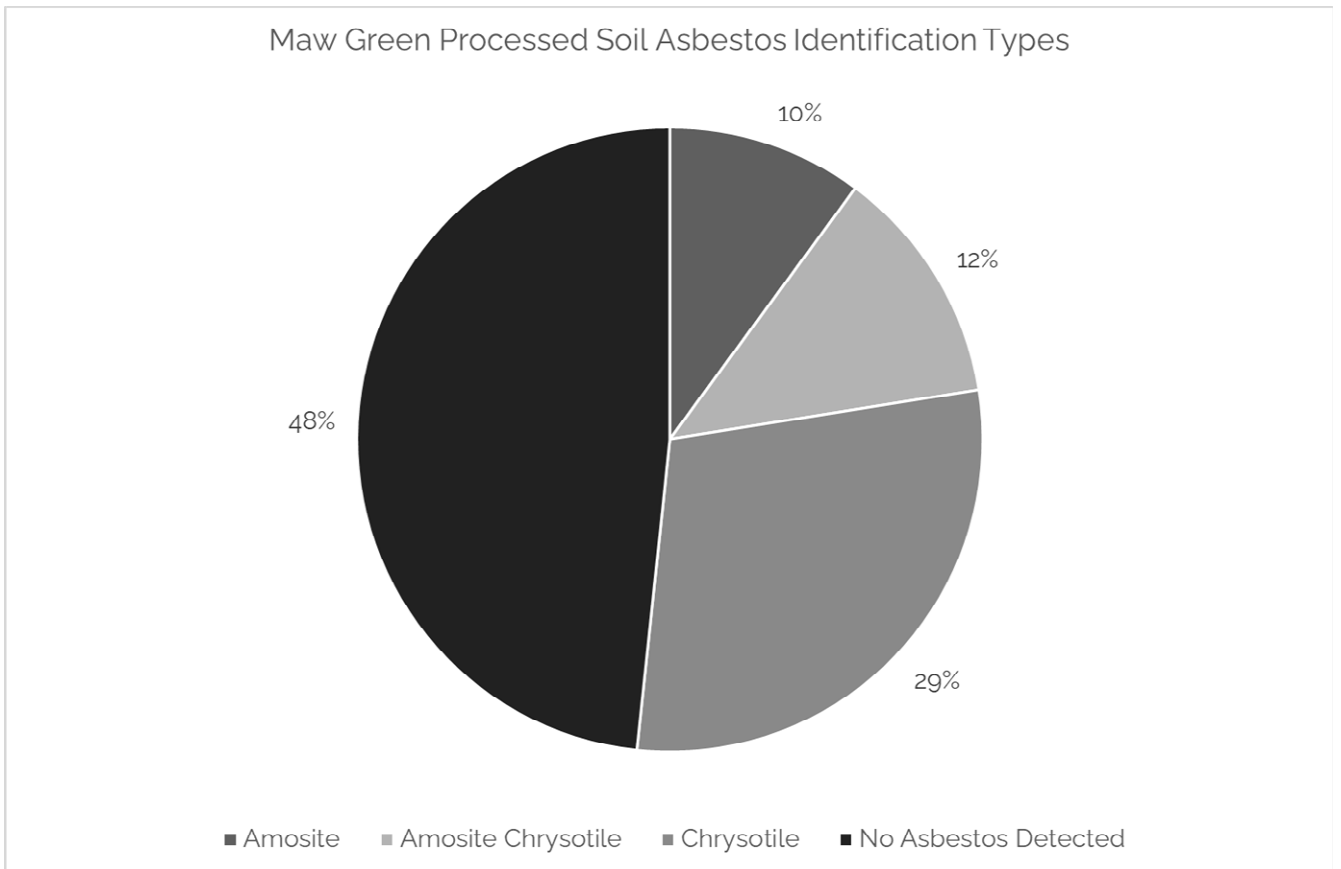

Figure F.10: Percentage detection of asbestos types in Maw Green post-processed soil sample results

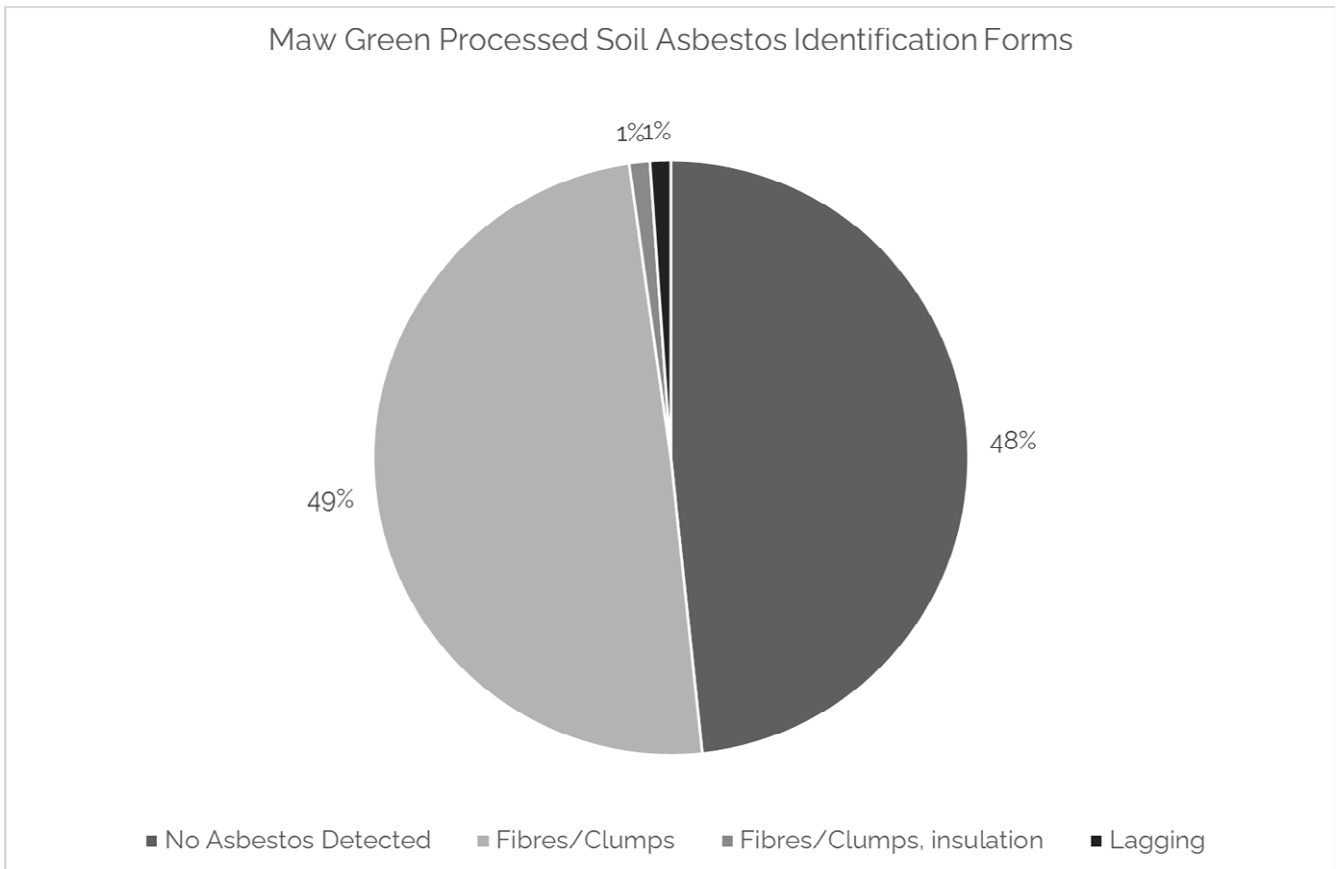

Figure F.11: Percentage detection of asbestos forms in Maw Green post-processed soil sample results

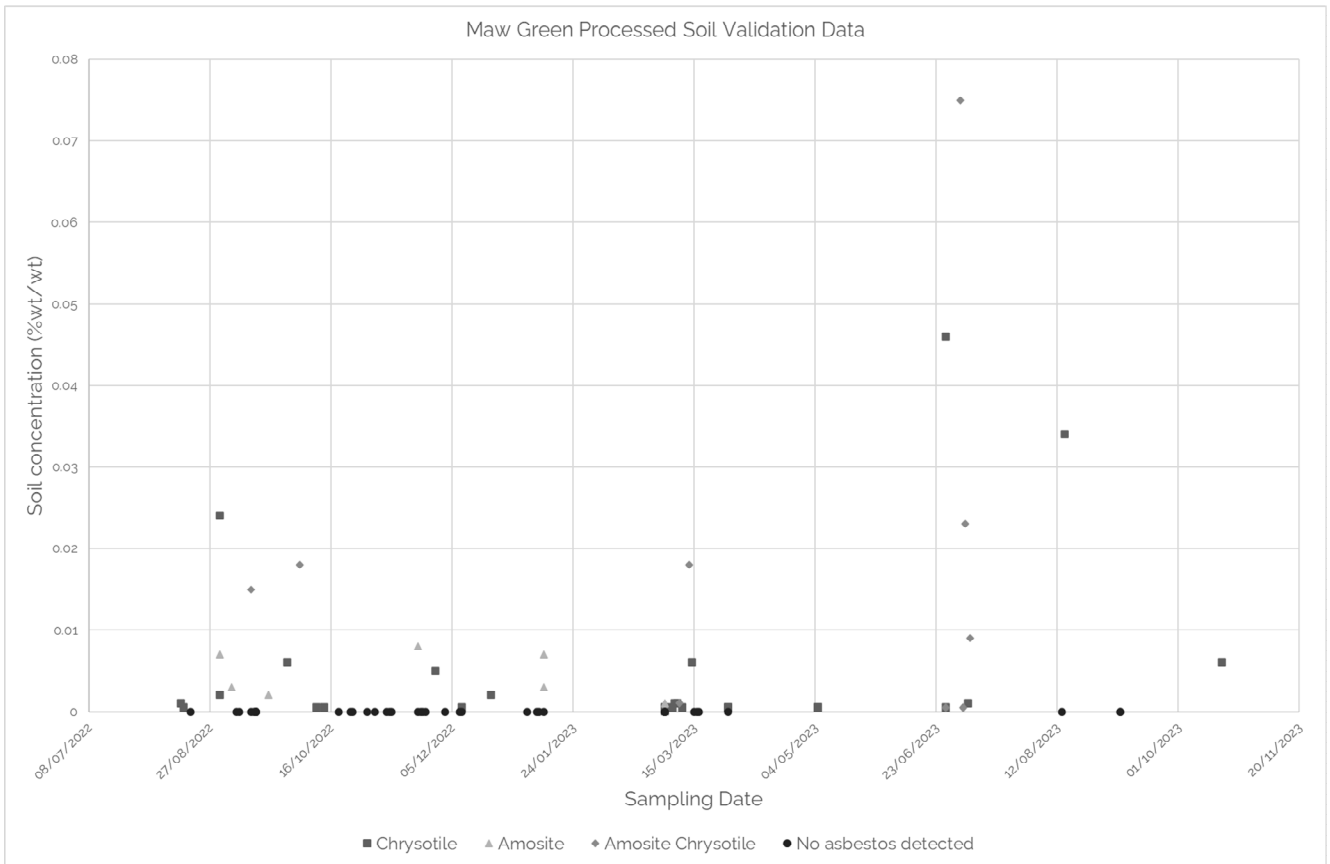

Figure F.12: Post-processed soil asbestos concentrations for Maw Green

Soil validation samples from Maw Green from December 2022 onwards have been re-tested for free fibres by fibre counting (Stage 3 in the SCA Blue Book method). The results for these 47 samples are all reported as <0.001%wt/wt (i.e. <LOQ) for free fibres. All soil validation results were originally tested for asbestos identification and gravimetric quantification (i.e. as per Stage 1 and Stage 2 of the SCA Blue Book method).

Table F.8: Summary details of post-processed soil moisture results for Maw Green

Parameter	Value
Total number of soil samples	89
Minimum	3%
Maximum	30%
5th percentile	8%
Lower quartile	10%

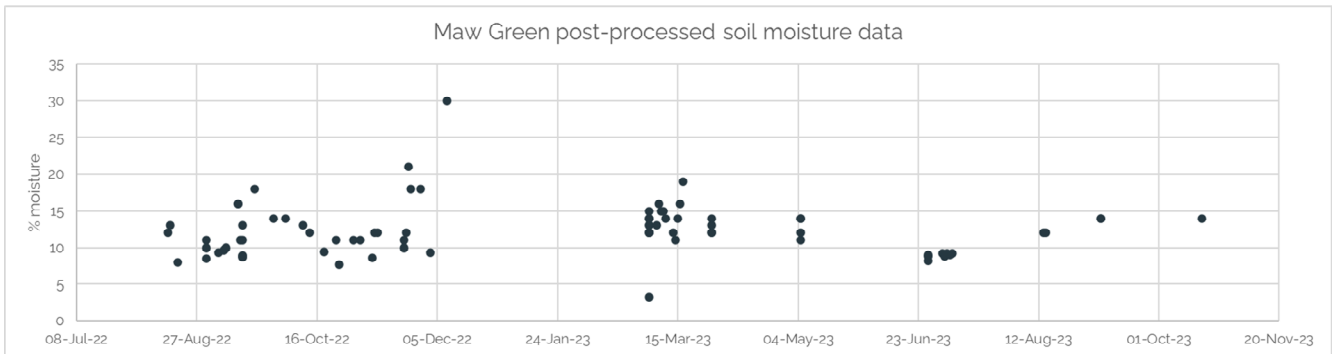
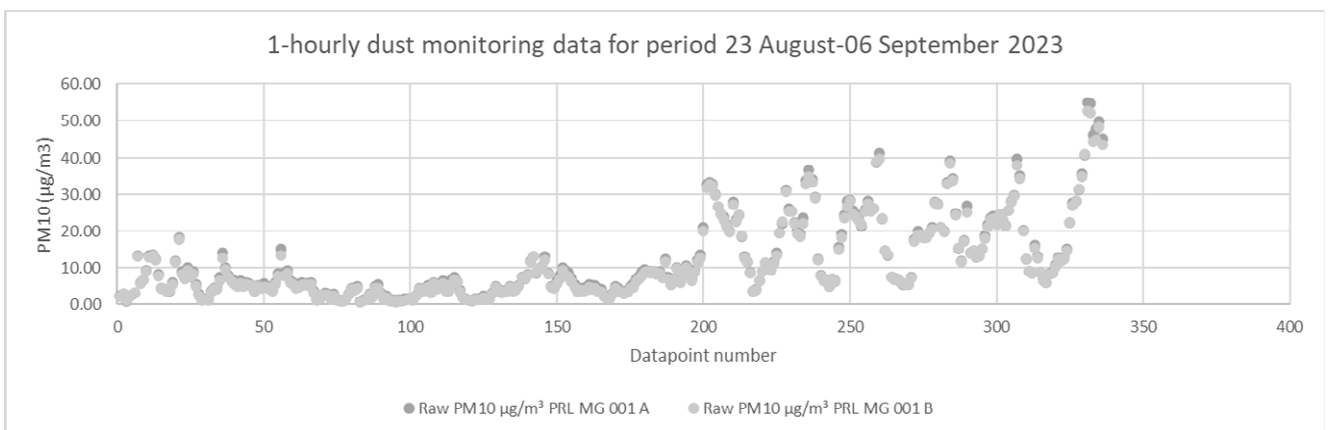
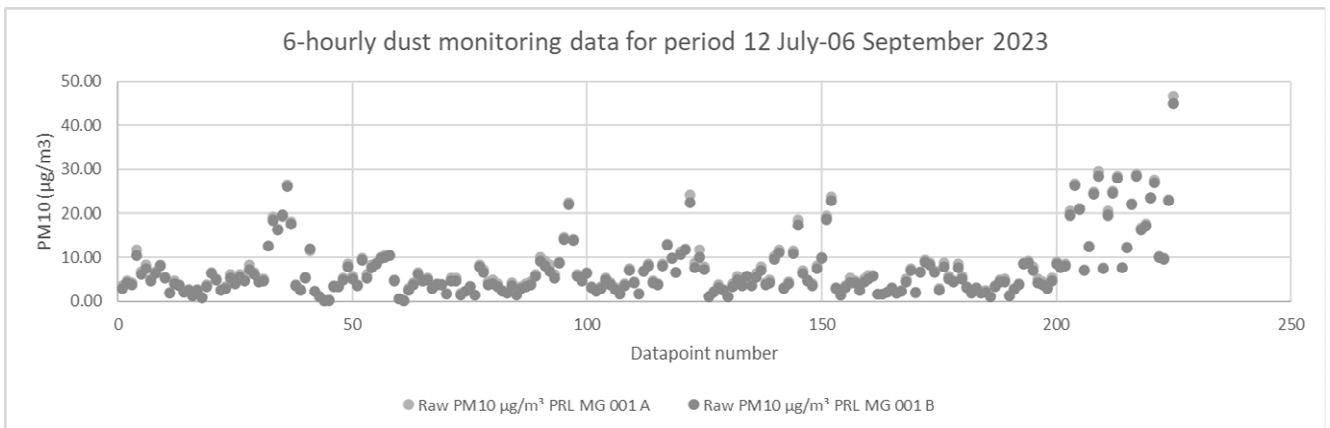

Figure F.13: Post-processed soil moisture results for Maw Green

Dust monitoring

A PurpleAir Flex Air Quality Monitor has been installed on the picking station at Maw Green that is capable of continuous monitoring for PM0.3-PM10. Data from this instrument is available from 12 July 2023 onwards. Data up to 06 September is graphed below.



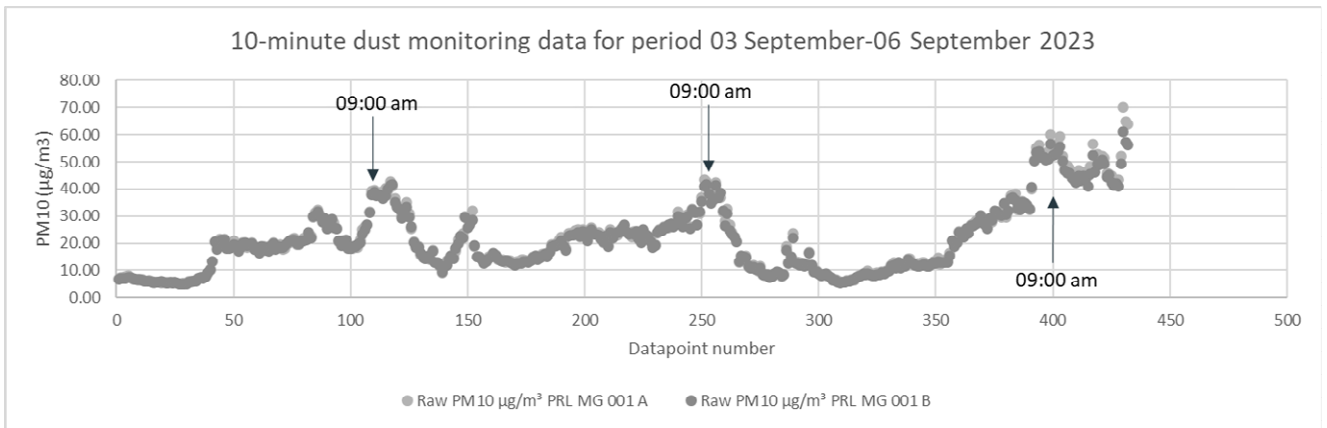

Figure F.14: (a) 6-hourly PM10 dust monitoring data, (b) 1-hourly PM10 dust monitoring data, and (c) 10-minute PM10 dust monitoring data for Maw Green

The location of the dust monitor is shown in the photographs below:



Figure F.15: Location of the Maw Green continuous dust monitor

Surface water treatment plant effluent sampling

Water samples have been taken from the surface water treatment plant over the period 07 September 2023 to 21 September 2023. The sample analysis certificates issued by Eurofins Chemtest have been

provided to me. All results are reported as "not detected" (i.e. no asbestos fibre has been detected on the filter from the submitted water sample).

Provectus data pertaining to Edwin Richards Quarry

The data provided to me, in summary, is:

- » Excel summary table of activity-based monitoring results for monitoring at the ERQ Soil Treatment Facility carried out between 08 May 2018 and 29 September 2023.
- » Individual certificates of analysis issued by IOM for the sample testing summarised in the table noted above
- » Pre-treatment soil reception testing analytical certificates issued by Eurofins for sampling undertaken by Provectus at ERQ STF between 02 August 2019 and 12 October 2022.
- » Post-treatment soil validation testing at ERQ STF, and accompanying Provectus soil validation reports for the period from 24 September 2019 to 22 March 2023
- » Laboratory certificates issued by Chemtest and Eurofins Chemtest for the analysis of asbestos fibres in water samples taken from the surface water treatment plant at ERQ STF from 27 August 2021 to 23 May 2022 and from 08 September 2023 to 04 October 2023



Figure F.16: Google Earth image of STF and asbestos soil treatment building for context

Activity-based sampling (air)

Air monitoring of the operational STF activities has been carried out at ERQ (typically daily) between 08 May 2018 and 05 December 2019, and between 05 February 2020 and 29 September 2023. The 2018-2019 monitoring was carried out by Envirochem (08 May – 19 July 2018) and Riverside (23 July 2018 onwards). The 2020-2023 monitoring was undertaken by Riverside (05 February 2020 – 12 July 2021) and Thames Laboratories (09 February – 30 June 2023), with Provectus undertaking the monitoring themselves between 13 July 2021 and 09 February 2023. Monitoring samples up until 06 September 2021 were analysed using PCOM. From 06 September 2021 onwards the monitoring samples have been analysed using scanning electron microscopy (SEM) to a lower limit of quantification (0.0005f/ml).

The individual monitoring locations are indicated in the sample location diagrams provided on the monitoring certificates issued by Envirochem/Riverside/Thames.

Table F.9: Summary details of air monitoring at ERQ

Monitoring Parameter	Value/Details	
	PCOM analysis	SEM analysis
Pump sampling rate	Varies from 2-16 litres per minute	16 litres per minute
Sample duration	Typically circa 1 hour (varies from 40-254 minutes)	90 minutes
Number of sampling points	Typically 4 (varies from 3-10)	1
Sample volume achieved	480 litres for Riverside 480-752 litres for Thames	1440 litres
Weather conditions at time of sampling	Not reported	Not reported
Analytical method	PCOM – carried out by Envirochem/Riverside	SEM – carried out by Institute of Occupational Medicine (IOM)
Limit of quantification achieved	Typically 0.01f/ml (varies from 0.0005-0.04f/ml)	0.0005f/ml
Reported concentrations	<LOQ	Typically <0.0005f/ml (maximum of 6.5 fibres equating to a concentration of 0.001f/ml)
Example site plan	<p>Works/Sample Location Diagram</p> <p>The diagram shows a rectangular layout. At the top center is a 'Conveyor'. Below it is a 'Picking Pod'. At the bottom center is a 'Soil Segregation Shed'. Four monitoring points are marked: L1000775 is to the left of the Picking Pod, L1000774 is to the right of the Picking Pod, L1000773 is at the bottom right corner, and L1000776 is at the bottom left corner.</p>	
Additional comments	<p>The four air monitoring/sampling locations are variously located within the 'asbestos shed' and the outside 'storage pad' depending on the activities taking place on the day of monitoring. Activity descriptions can be split between 'original operation of the screener and picking station', 'no external pad activity and with screener covered and fitted with a HEPA filter', 'no external pad activity and screener uncovered', 'perimeter</p>	

of storage pad', 'asbestos shed with no processing activity', and 'no external pad activity and screening stopped'.

The SEM dataset from Provectus/Thames/IOM monitoring and analysis for ERQ can be presented as follows:

Table F.10: Summary details of SEM air monitoring results for ERQ

Parameter	Value
Total number of air samples	809
Number of samples with zero fibres reported	616
Number of samples with countable fibres present	193
Percent of samples with countable fibres	24%
95 th percentile fibre count	2
99 th percentile fibre count	4
Maximum fibre count	6.5
Maximum concentration (total)	0.001f/ml
Maximum concentration (amosite)	0.0007f/ml
Maximum concentration (chrysotile)	0.0009f/ml
Percent of samples with concentration >LOQ	3%

Table F.11: Summary details of air monitoring results split between phases of operation

Parameter	Screener in operation and uncovered	Screener in operation and covered + HEPA filter	No screening operation
Total number of air samples	88	128	593
Number of samples with zero fibres reported	49	95	472
Number of samples with countable fibres present	39	33	121
Percent of samples with countable fibres	44	26	20
95 th percentile fibre count	3	2	2
99 th percentile fibre count	5.5	3	4
Maximum fibre count	5.5	4	6.5



Maximum concentration (all asbestos)	0.0009 f/ml	0.0007 f/ml	0.001 f/ml
Maximum concentration (chrysotile)	0.0009 f/ml	0.0007 f/ml	0.0007 f/ml
Maximum concentration (amosite)	0.0005 f/ml	< 0.0005 f/ml	0.0007 f/ml
Percent of sample concentrations >LOQ	6%	1%	4%

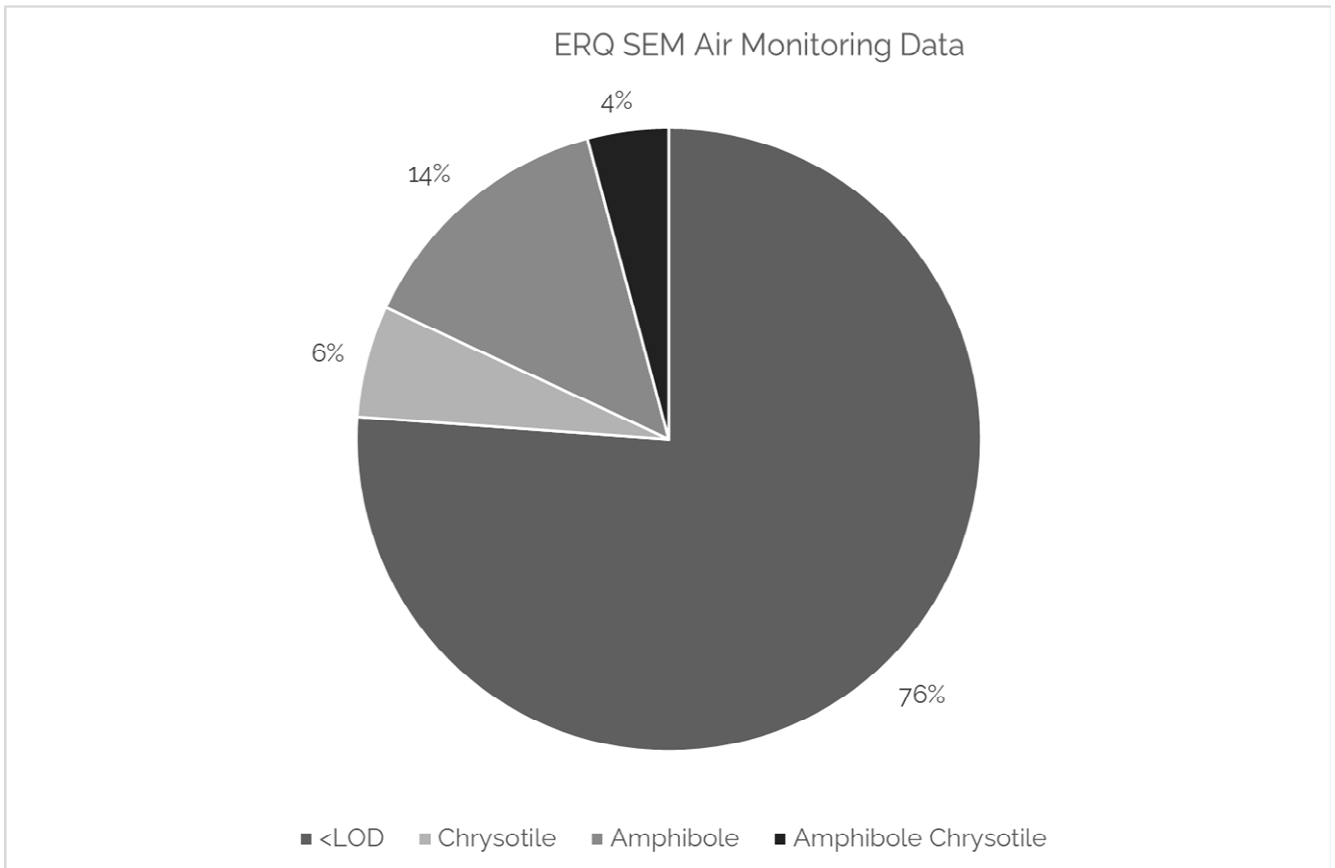

Figure F.17: Percentage detection of asbestos types in ERQ SEM air monitoring results

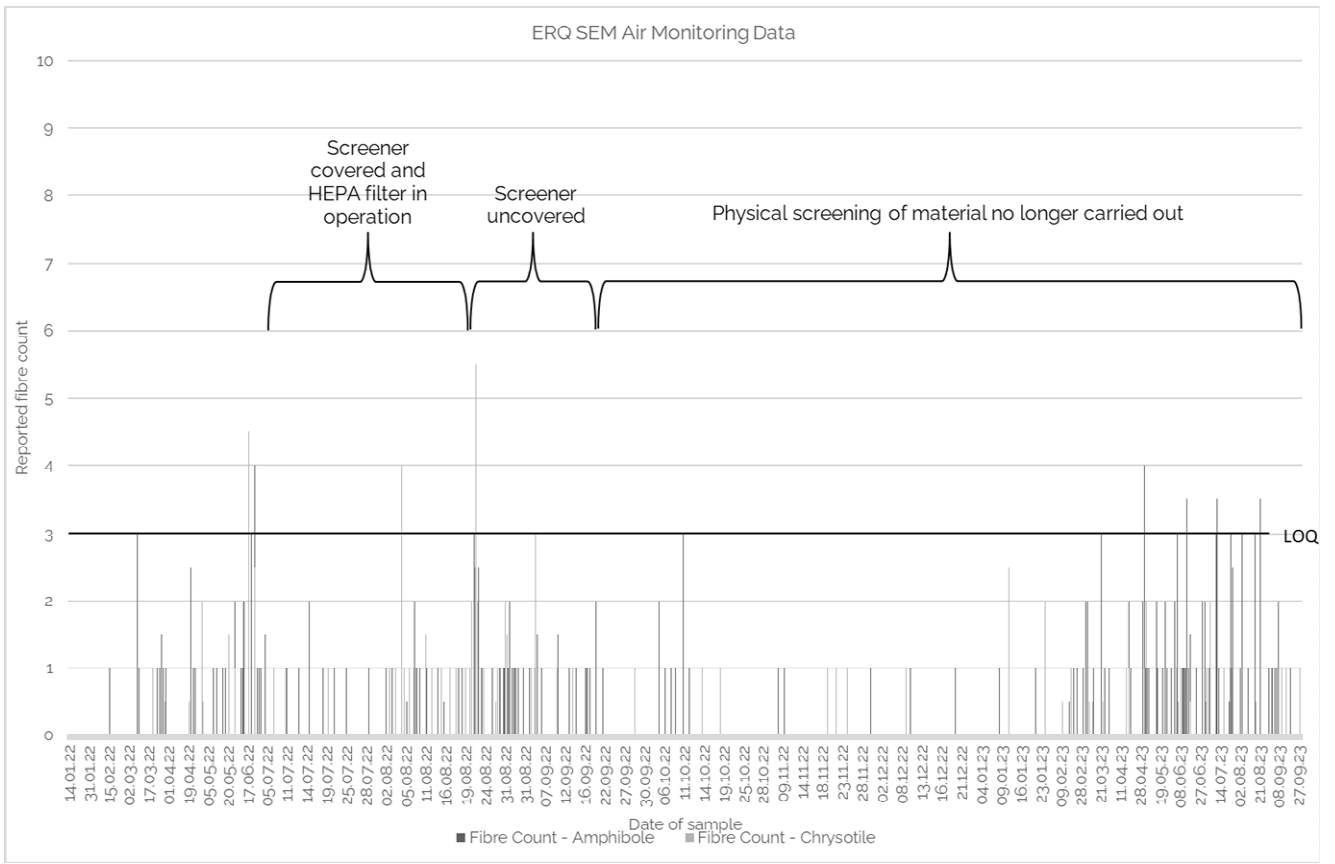

Figure F.18: SEM fibre count results for ERQ air monitoring

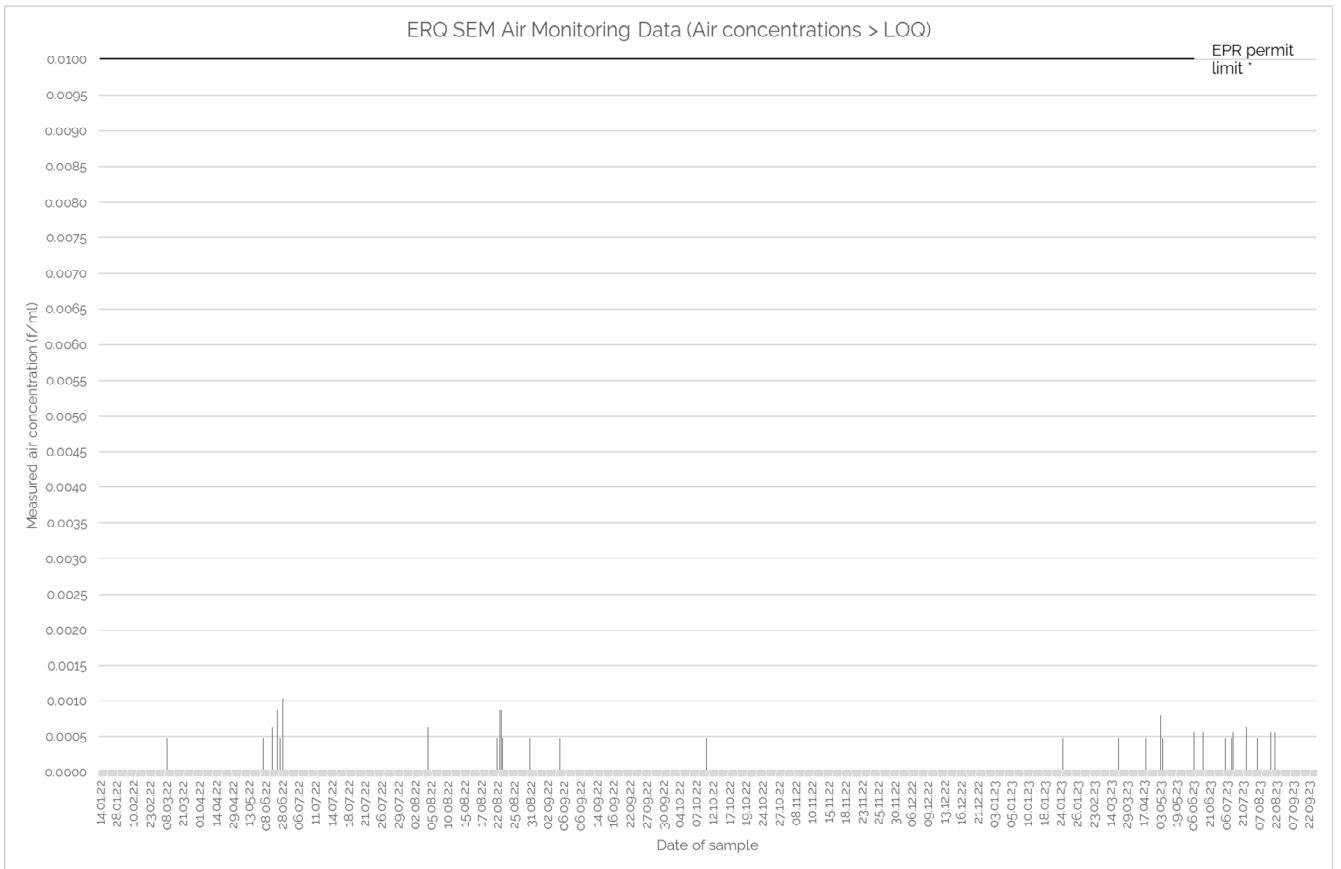

Figure F.19: SEM asbestos fibre air concentrations for ERQ air monitoring

* Note the EPR permit limit illustrated in Figure F.19 is defined as a PCOM concentration, whereas the measured concentrations are SEM measurements. Correcting for the unit difference would result in either a reduction in the illustrated measured concentrations or an increase in the illustrated permit limit.

Example locations for the air monitoring at ERQ are shown in the photographs below taken on 20 June 2023.



Figure F.20: Example locations for SEM air monitoring at ERQ

Pre-processed acceptance soil test data

Sample analysis laboratory certificates issued by Chemtest/Eurofins Chemtest for samples of pre-processed soils for the period of 02 August 2019 to 12 October 2022 have been provided to me.

This data comprises asbestos gravimetric analysis test data for pre-processed soil from approximately 440 different sites of origin sampled over the period 02 August 2019 to 12 October 2022. The sampling protocol utilised by Provectus for this is as follows:

Table F.12: Provectus sampling frequencies

Volume of soil (t)	No. of samples needed (before or during acceptance at STF)
< 100	1
100 - 500	2
500 +	2 + 1 for every 500t

The dataset can be described and presented as follows:

Table F.13: Summary details of pre-processed acceptance soil test results for ERQ

Parameter	Value
Total number of soil samples	768
Number of samples with no asbestos detected	589
Number of samples with detectable asbestos present	179
Number of samples with asbestos concentration > LOQ	134
Median concentration	<0.001%wt/wt (<LOQ)
Upper quartile	<0.001%wt/wt (<LOQ)
90 th percentile concentration	0.003%wt/wt
95 th percentile concentration	0.009%wt/wt
Maximum concentration	4.7% (asbestos cement fragment)

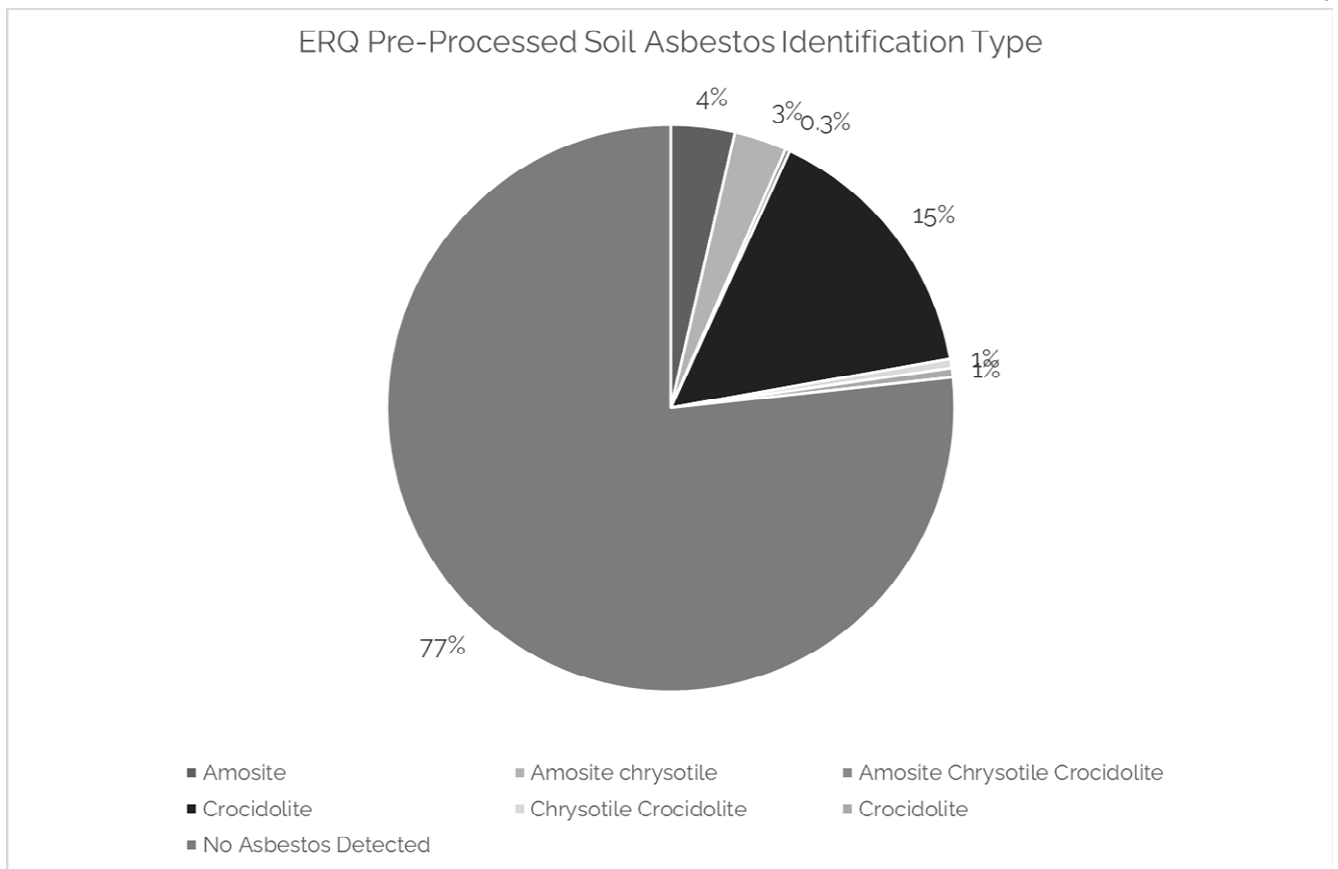

Figure F.21: Percentage detection of asbestos types in ERQ pre-processed soil sample results

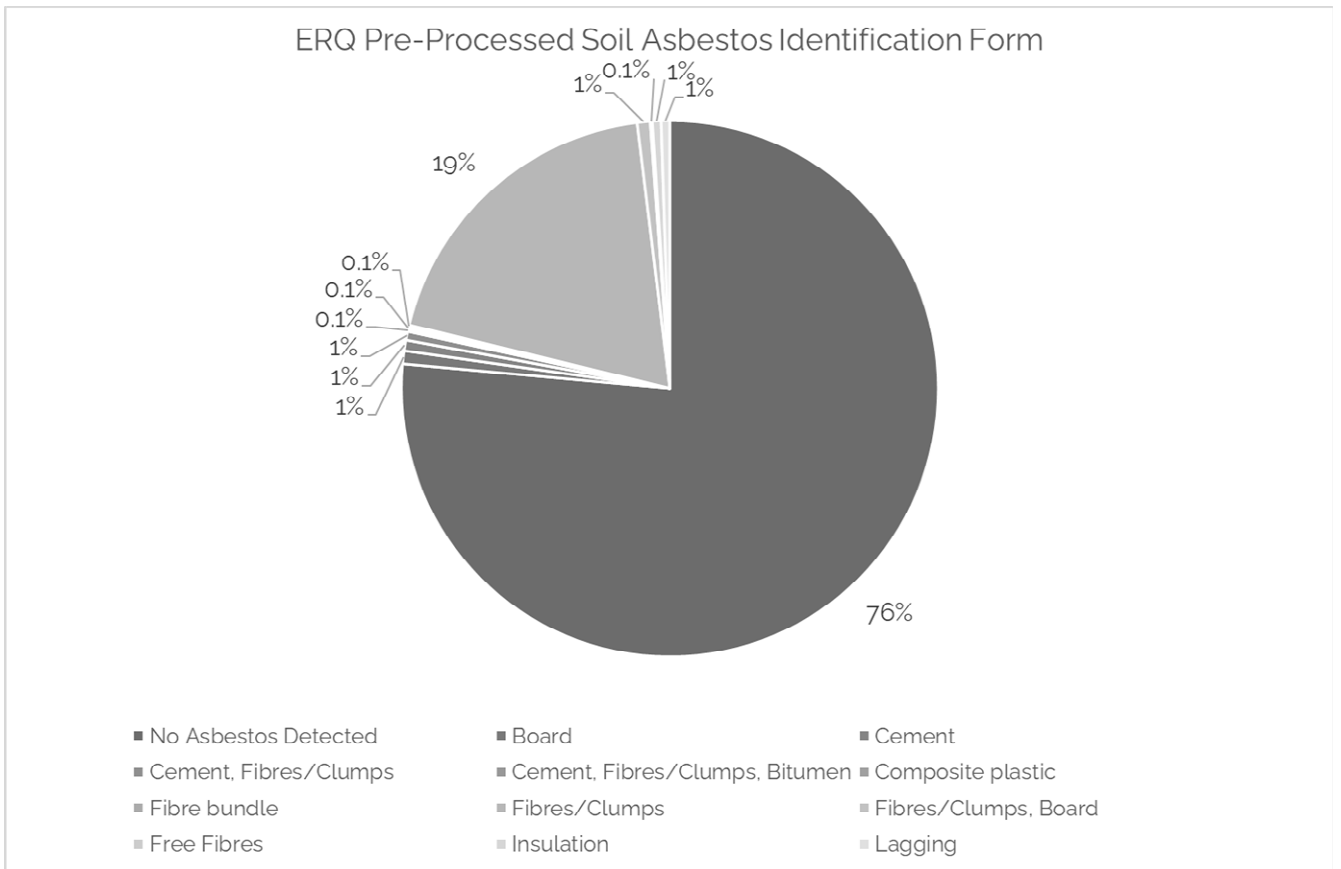

Figure F.22: Percentage detection of asbestos forms in ERQ pre-processed soil sample results

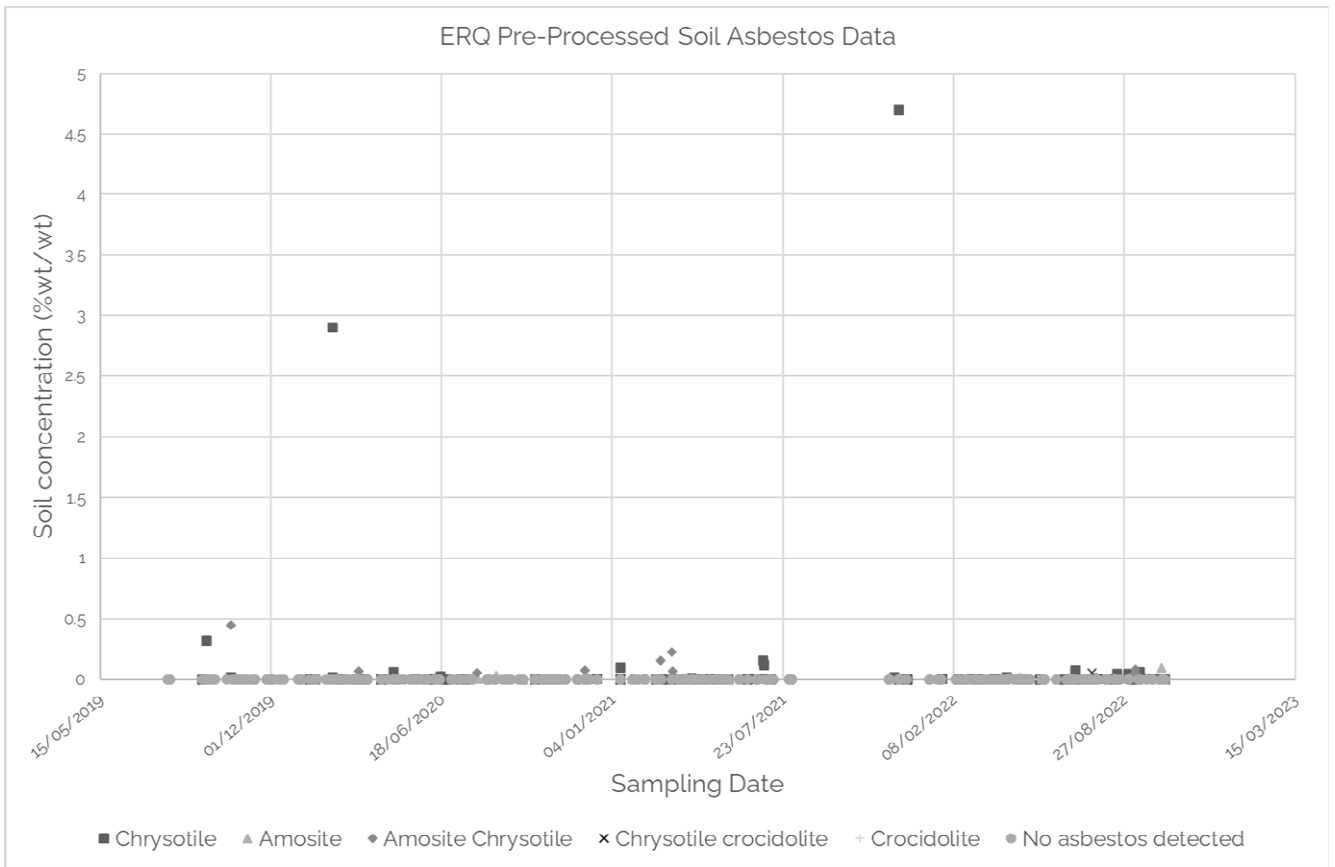

Figure F.23: Pre-processed soil asbestos concentrations for ERQ

Table F.14: Summary details of pre-processed soil moisture results for ERQ

Parameter	Value
Total number of soil samples	769
Minimum	0.62%
Maximum	52%
5th percentile	6.1%
Lower quartile	10%

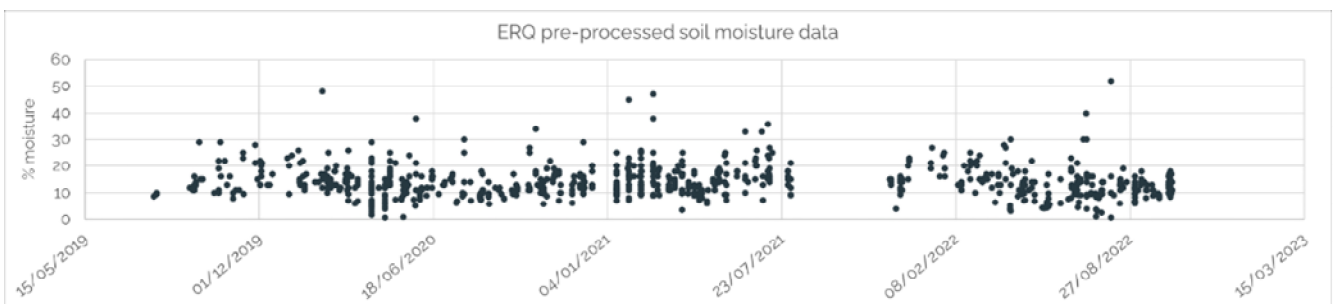

Figure F.24: Pre-processed soil moisture results for ERQ

Post-processed soil validation data

This data comprises asbestos gravimetric analysis test data for post-processed soil data from approximately 270 different sites of origin sampled over the period 24 September 2019 – 22 March 2023. The dataset can be presented as follows:

Table F.15: Summary of post-processed soil sites of origin and processed amounts for ERQ

Number of Input Material Projects (i.e. sites of origin)	Total Material Validated (t)	Average Batch Size (t)
270 (received tonnage from sites varies considerably)	83494.59	5566.306

Table F.16: Summary details of post-processed validation soil test results for ERQ

Parameter	Value
Total number of soil samples	278
Number of samples with no asbestos detected	207
Number of samples with detectable asbestos present	71
Number of samples with asbestos concentration > LOQ	38
Median concentration	<LOQ
90th percentile concentration	0.002%wt/wt
95th percentile concentration	0.03%wt/wt
Maximum concentration	0.09%wt/wt

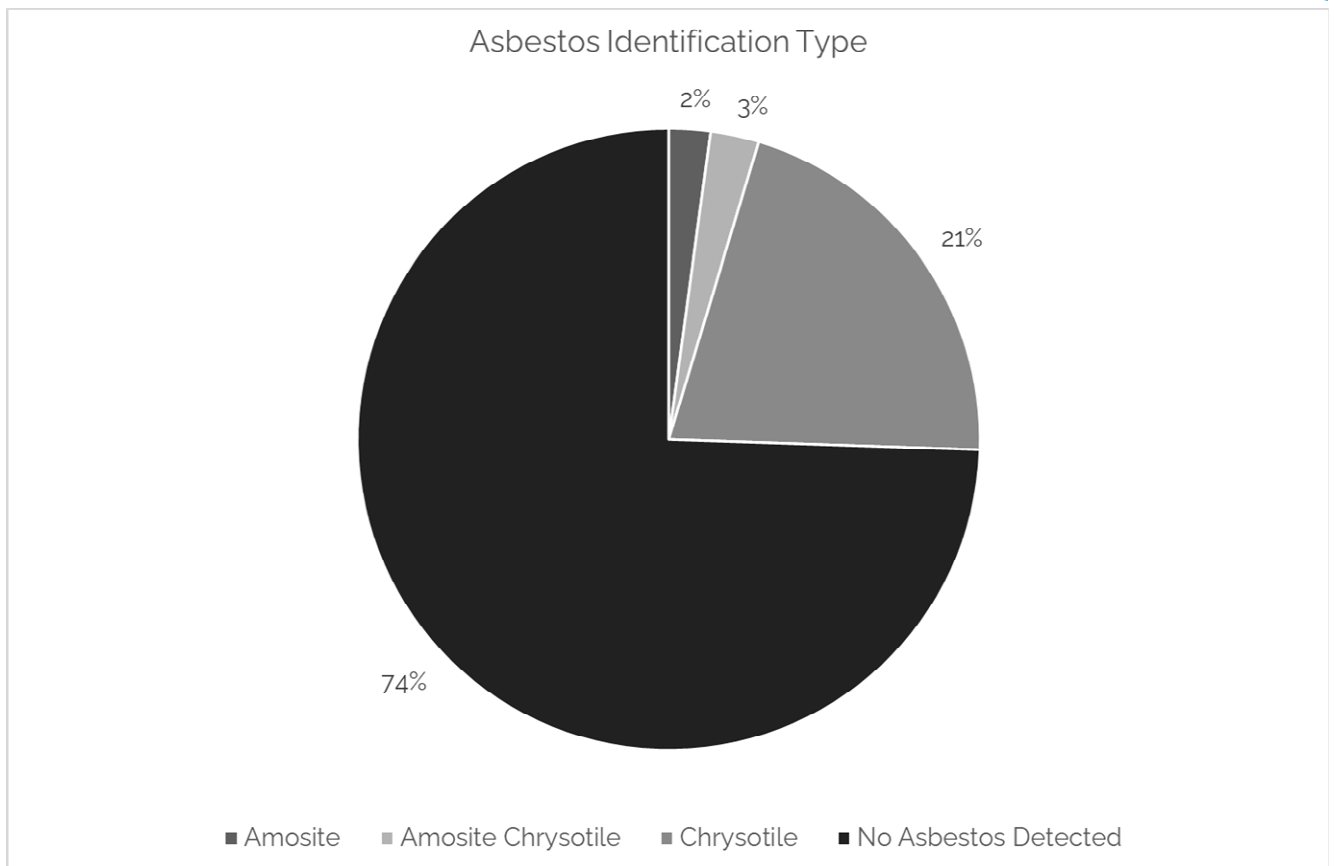

Figure F.25: Percentage detection of asbestos types in ERQ post-processed soil sample results

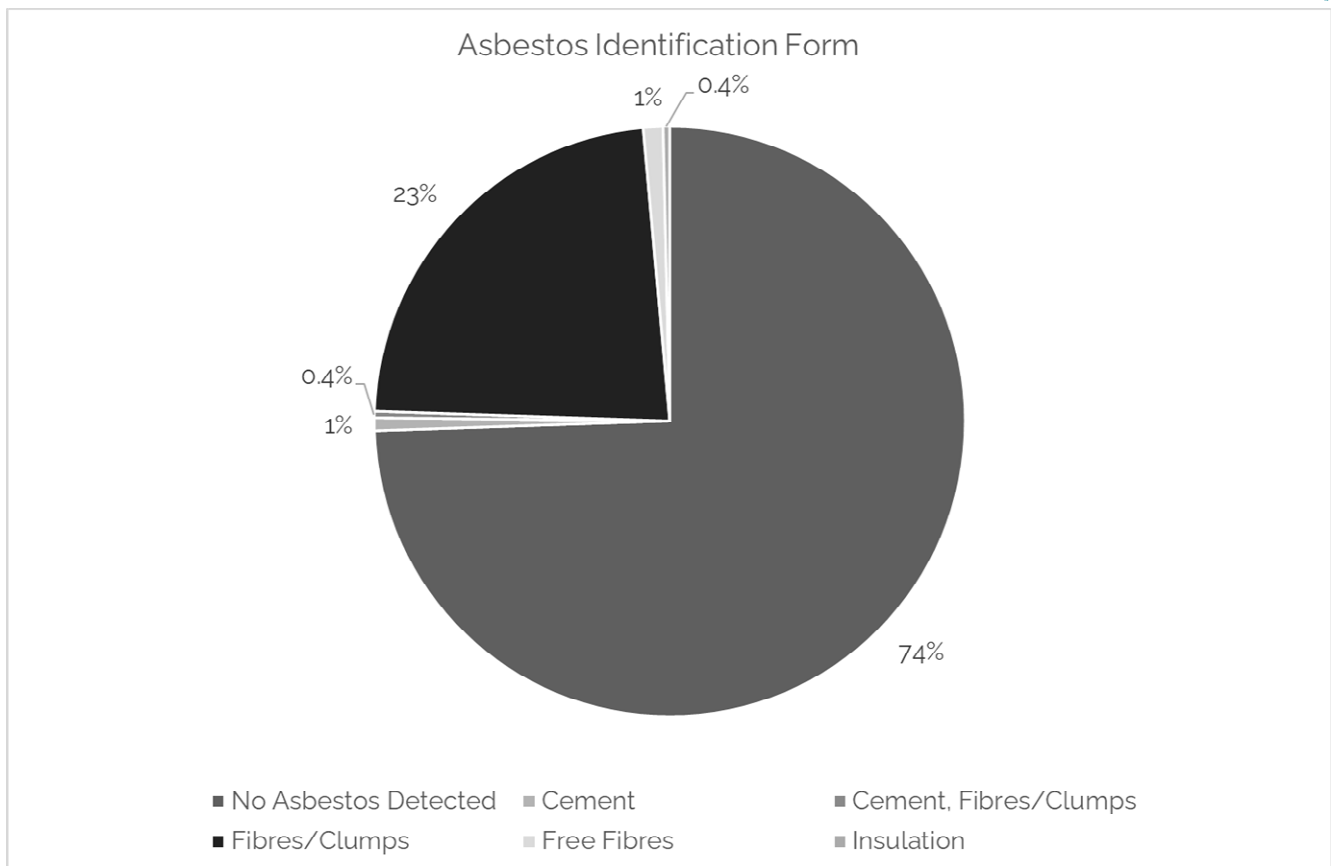

Figure F.26: Percentage detection of asbestos forms in ERQ post-processed soil sample results

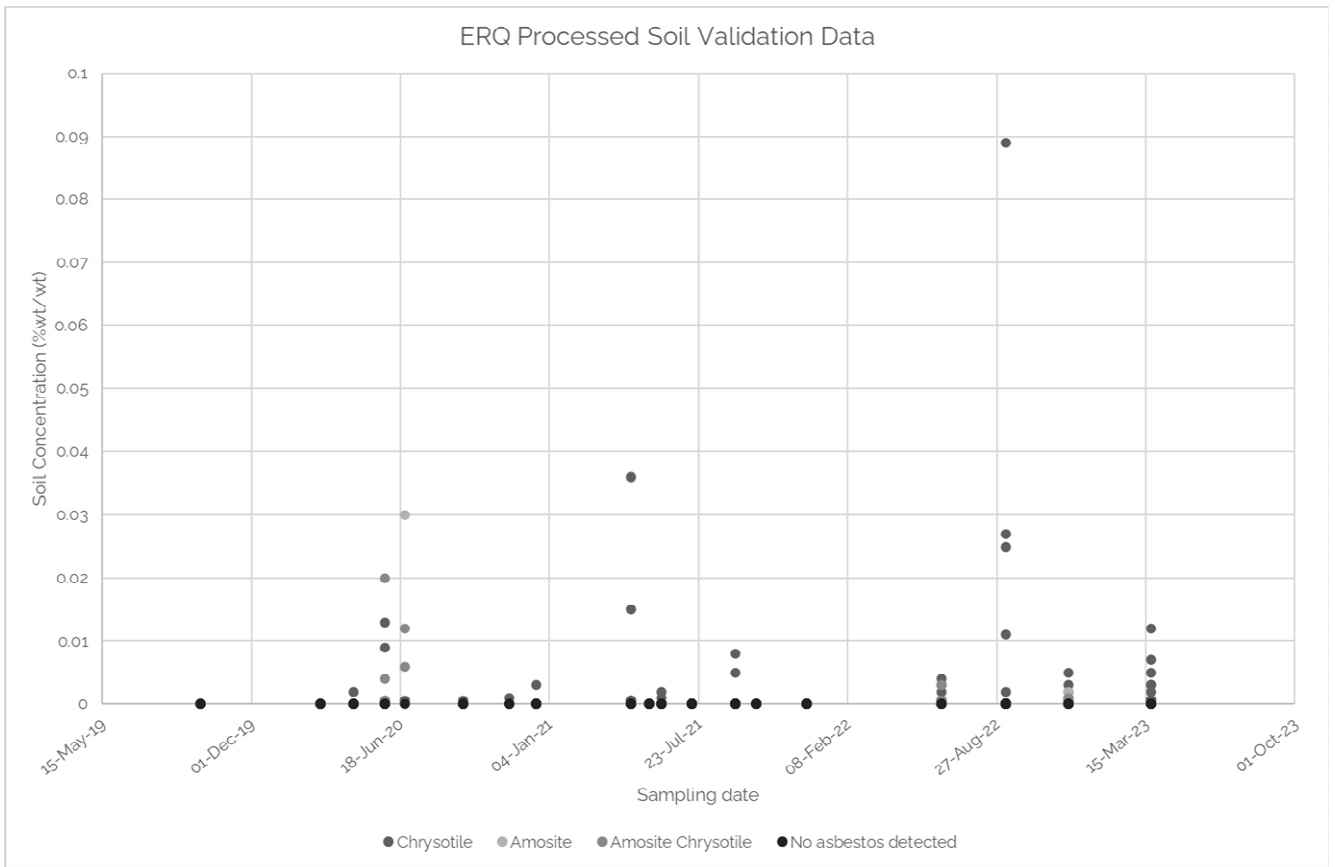

Figure F.27: Post-processed soil asbestos concentrations for ERQ

Table F.17: Summary details of post-processed soil moisture results for ERQ

Parameter	Value
Total number of soil samples	253
Minimum	2%
Maximum	32%
5th percentile	5%
Lower quartile	9%

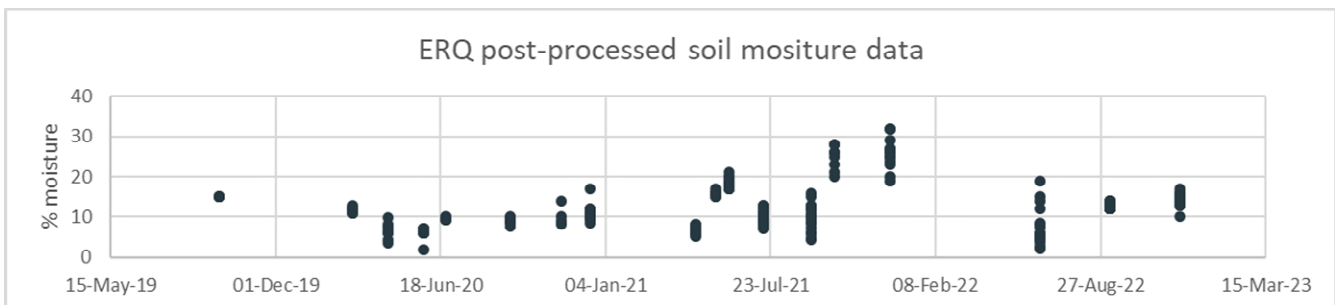

Figure F.28: Post-processed soil moisture results for ERQ

Supplementary soil sampling

Provectus commissioned more detailed soil laboratory testing for soil samples taken from the Maw Green STF during August 2023. Samples were variously taken of stockpiled soil to be processed, the finer fraction of screened soil, and the middle fraction of screened soil after it had passed through the picking station. Samples were also taken of the sedimented dust on the concrete treatment pad. The samples were submitted to Eurofins Chemtest for testing using a UKAS-accredited three-stage asbestos in soil quantification method. The results for those samples are shown in Table F.18 for comparison.

Table F.18: Pre-, and post- screening and picking soil sample data from Maw Green

Sample ID	Asbestos Identification (Stage 1)	Asbestos by Gravimetry (Stage 2)	Asbestos By Fibre Counting (Stage 3)
ASB 12/PS14/08	Fibres/Clumps, Chrysotile	0.001	<0.001
ASB 12/AS14/08	Fibres/Clumps, Chrysotile	0.003	<0.001
ASB 12/AP14/08	No Asbestos Detected	-	-
ASB 12/PS15/08	No Asbestos Detected	-	-
ASB 12/AS15/08	No Asbestos Detected	-	-
ASB 12/AP15/08	Fibres/Clumps, Chrysotile	<0.001	<0.001
ASB 12/PS16/08	Insulation, Amosite, Chrysotile	0.008	<0.001
ASB 12/AS16/08	No Asbestos Detected	-	-
ASB 12/AP16/08	Fibres/Clumps, Amosite	<0.001	<0.001
ASB 12/PS21/08	Fibres/Clumps, Board, Amosite, Chrysotile	0.005	<0.001
ASB 12/AS21/08	Fibres/Clumps, Chrysotile	0.002	<0.001
ASB 12/AP21/08	Fibres/Clumps, Chrysotile	<0.001	<0.001
ASB 12/PS22/08	Fibres/Clumps, Chrysotile	0.001	<0.001
ASB 12/AS22/08	Fibres/Clumps, Chrysotile	0.001	<0.001
ASB 12/AP22/08	Fibres/Clumps, Chrysotile	0.002	<0.001
ASB 12/PS23/08	Fibres/Clumps, Amosite, Chrysotile	0.002	<0.001
ASB 12/AS23/08	Fibres/Clumps, Chrysotile	<0.001	<0.001
ASB 12/AP23/08	Fibres/Clumps, Chrysotile	0.002	<0.001
ASB 12/PS24/08	Fibres/Clumps Chrysotile	<0.001	<0.001
ASB 12/AS24/08	Fibres/Clumps Chrysotile	0.001	<0.001
ASB 12/AP24/08	Fibres/Clumps Amosite	0.003	<0.001
ASB 12/PS25/08	- No Asbestos Detected	-	-
ASB 12/AS25/08	Fibres/Clumps Chrysotile	0.002	<0.001
ASB 12/AP25/08	Fibres/Clumps Amosite	0.001	<0.001

Table notes:

All values quoted as %wt/wt (equivalent to mg/kg).

Sample ID codes are: ASB12 = soil treatment batch number; PS = soil input pre-screening; AS = fines fraction after screening; AP = mid-size fraction after picking; xx/xx = day/month of sample date.

In addition to the additional UKAS-accredited testing outlined above, Provectus sent additional samples to DETS for testing using a more sensitive fibre counting method that reports the number of respirable asbestos fibres in the PM10 dust fraction of the soil sample (i.e. that fraction that is more likely to become airborne due to soil disturbance activities).

Provectus obtained a total of 36 soil samples for analysis by DETS. Further details of the samples locations, dates and analysis results are presented in Table F.19 below.

Table F.19: Provectus soil sample DETS results

Sample Ref. Number*	Sample Location	Asbestos Screen Description	Respirable Fibre Concentration (f/mg)
ASB 12/PS 14/08	Pre-screen stockpile	Not detected	21700
ASB 12/AS 14/08	Post-screen stockpile (Fines)	Chrysotile present in bundles	52400
ASB 12/AP 14/08	After picking station (mid-size)	Amosite & Chrysotile present in microscopic insulation	44700
ASB 12/PS 15/08	Pre-screen stockpile	Chrysotile present in bundles	44700
ASB 12/AS 15/08	Post-screen stockpile (Fines)	Chrysotile present in microscopic insulation debris & bundles	34500
ASB 12/PS 16/08	Pre-screen stockpile	Not detected	28100
ASB 12/AS 16/08	Post-screen stockpile (Fines)	Not detected	58700
ASB 12/AP 16/08	After picking station (mid-size)	Not detected	42100
ASB 12/PS 17/08	Pre-screen stockpile	Chrysotile present in bundles	17900
ASB 12/AS 17/08	Post-screen stockpile (Fines)	Not detected	28100
ASB 12/AP 17/08	After picking station (mid-size)	Not detected	21700
ASB 12/PS 18/08	Pre-screen stockpile	Not detected	7660
ASB 12/AS 18/08	Post-screen stockpile (Fines)	Not detected	19200
ASB 12/AP 18/08	After picking station (mid-size)	Amosite & Chrysotile present in microscopic insulation	28100
ASB 12/PS 21/08	Pre-screen stockpile	Chrysotile fibres present in microscopic insulation	19200
ASB 12/AS 21/08	Post-screen stockpile (Fines)	Not detected	12800
ASB 12/AP 21/08	After picking station (mid-size)	Amosite present as bundles	24300
ASB 12/PS 22/08	Pre-screen stockpile	Amosite & Chrysotile present as fibre bundles	5110
ASB 12/AS 22/08	Post-screen stockpile (Fines)	Chrysotile present in bundles	16600
ASB 12/AP 22/08	After picking station (mid-size)	Chrysotile present in bundles	39600

Pad 17/08	Concrete slab	Not detected	12800
Pad 18/08	Concrete slab	Not detected	15300
Pad 21/08	Concrete slab	Chrysotile present in microscopic cement and as loose bundles	25500
Pad 22/08	Concrete slab	Not detected	30600
ASB 12/PS 23/08	Pre-screen stockpile	Not reported	38300
ASB 12/AS 23/08	Post-screen stockpile (Fines)	Not reported	16600
ASB 12/AP 23/08	After picking station (mid-size)	Not reported	15300
ASB 12/PS 24/08	Pre-screen stockpile	Not reported	28100
ASB 12/AS 24/08	Post-screen stockpile (Fines)	Not reported	17900
ASB 12/AP 24/08	After picking station (mid-size)	Not reported	48500
ASB 12/PS 25/08	Pre-screen stockpile	Not reported	17900
ASB 12/AS 25/08	Post-screen stockpile (Fines)	Not reported	30600
ASB 12/AP 25/08	After picking station (mid-size)	Not reported	30600
Pad 23/08	Concrete slab	Not reported	20400
Pad 24/08	Concrete slab	Not reported	6390
Pad 25/08	Concrete slab	Not reported	25500

Surface water treatment plant effluent sampling

Water samples have been taken from the surface water treatment plant over the periods 27 August 2021 to 23 May 2022 and from 08 September 2023 to 04 October 2023. All results are reported as "not detected" (i.e. no asbestos fibre has been detected on the filter from the submitted water sample).

Hydrock monitoring

Hydrock undertook airborne asbestos, dust, and soil sampling over four days at the MG STF between 03-06 September 2023. The work is detailed in the following factual technical note.

Factual reporting note

Project name	Maw green		
Title	Maw Green Monitoring - Factual report		
Document reference	28480-HYD-XX-XX-TN-GE-0003		
Author	James Macfarlane and Becky Homer		
Revision	P01		
Date	6 November 2023	Approved	✓

1. Introduction

FCC Environment and Provectus Remediation (FCC&P) are currently considering an appeal against the Environment Agency's decision to partially refuse submission for an Environmental Permit variation at the treatment facility at Maw Green Rd, Crewe CW1 5NG.

To support the appeal, FCC&P have requested Hydrock to conduct a counter sampling exercise at the site, aiming to provide additional data for a detailed assessment. This factual report has been carried out in accordance with Hydrock's fee proposal 28480-HYD-XX-XX-FP-GE-003, dated June 28, 2023, under the directive of Jon Owens from Provectus Remediation Ltd, acting on behalf of FCC Environment.

This report presents the findings of the counter sampling exercise for further evaluation by relevant parties.

Aims and Objectives

The relevant aims and objectives, and which forms the basis for the scope of works, is as follows:

- a. Obtain four asbestos in air monitoring points daily from the following predetermined locations;
 - » One upwind sample approximately 50m of the main processing area;
 - » One downwind sample directly adjacent to the main processing area;
 - » One downwind sample approximately 50m of the main processing area; and
 - » One downwind sample approximately 100m of the main processing area;
- b. All samples to be analysed by Scanning Electron Microscopy (SEM) to achieve a minimum Limit of Detection (LoD) of 0.00005f/ml. Where required, modification of the volume of air sampled and number of SEM 'screens' to ensure the low LoD can be attained;
- c. Obtain for laboratory analysis six composite soils samples per day from the following predetermined locations;
 - » Two samples of the processing stockpile prior treatment for laboratory analysis;
 - » Two samples of the processed fines stockpile post treatment for laboratory analysis; and
 - » Two samples of any dust/debris from the treatment slab downwind of the main processing area for laboratory analysis;
- d. Laboratory analysis of the soils was to include;

- » Screening for asbestos presence/absence (with asbestos identification); and
- » Supplementary Asbestos: Respirable Fibres in Dust analysis (PCOM) on all positive samples. Results to be report in respirable fibres per milligram (f/mg);
- e. Record the following qualitative and quantitative site data during the monitoring and sampling period(s):
 - » Measured airborne particulate and aerosol data such as dust, smoke, fumes and mists;
 - » Quantitative and quantitative weather data; and
 - » Photographs.

2. Scope of works

To fulfil the aims and objectives of the project brief, the following scope of works were proposed;

- a. Hydrock Consultants.
 - » Four days Hydrock site supervision and works coordination;
 - » Collection of site conditions, activities and weather data;
 - » Collection of soil samples for analysis by DETS/Suez Laboratories; and
 - » Compilation of the factual data (this report).
- b. Lucion Environmental.
 - » Four days site attendance by a senior BOHS P402 qualified asbestos analyst;
 - » Collection of four asbestos in air fibre monitoring points per day, with subsequent analysis of samples using Scanning Electron Microscopy (SEM);
 - » Project support by a Technical Consultant holding 'Certificate of Competence (Asbestos)';
 - » Compilation of a factual report summarising the results of the site attendance and SEM analysis by the Technical Consultant holding 'Certificate of Competence (Asbestos).
- c. DETS/Suez Laboratories.
 - » Analysis of soil samples (taken by Hydrock) for asbestos screen/ID (presence/absence); with
 - » Supplementary analysis of asbestos respirable fibres in dust (PCOM) on all positive samples.

Hydrock acknowledges that all data supplied by Lucion and DETS were generally conducted in accordance with their respective UKAS accreditations and standard operating procedures. However, it's important to note that in certain instances, Lucion and DETS may have developed analysis methods that deviate from standard procedures to accommodate the specific requirements of their outputs, such as achieving a low limit of detection for SEM and Respirable Fibres in Dust analysis in f/mg.

Consequently, the results provided by Lucion and DETS may fall outside the scope of their respective UKAS accreditation.

2.1.1 Assumptions and deviation

In a departure from the initially proposed scope of work, Thames Laboratory Ltd., under the direction of Provectus, conducted the final day of air monitoring on September 7th. This was necessitated by Lucion's inability to allocate resources to the project on the fourth day.

The subsequent SEM analysis of the four air samples collected by Thames Laboratory was carried out by IOM Laboratories Ltd.

3. Site Conditions

3.1 Summary

Site works were conducted from the 4th to the 7th of September 2023. Throughout the monitoring period, the weather conditions were generally hot, with temperatures ranging from 16.9°C to 25.4°C, and there was minimal precipitation. Clear skies prevailed due to a high-pressure weather system in the western region of England.

Four air monitoring locations were set up daily, including two downwind, one upwind, and one directly adjacent to the processing area, in line with the project's scope of work. While the overall monitor placements were determined by the primary project objectives, specific locations were adjusted daily to account for changes in wind direction and speed. The choice of monitoring locations was based on data from the onsite weather station, reviewed each morning, and discussions with the onsite Asbestos Analyst.

The supervising Asbestos Analyst monitored all pumps at hourly intervals. Provectus actively processed materials daily between 8:00 am and 4:00 pm and used water suppressants over the slab and processing area at least once a day.

Hydrock's observations of the pre-screened materials indicated that the soils were primarily gravelly and clayey Made Ground, with frequent metal, plastic, brick, and concrete fragments (as seen in Photographs 3, 13, 20, and 26). During the sampling of the pre-screened materials, Hydrock did not identify any visible asbestos-containing materials (ACM). However, it's important to note that once the daily processing operations commenced, Hydrock personnel were not permitted to approach the treatment area or enter the picking station unless they were conducting sampling.

In total, Provectus processed approximately 380 tonnes of pre-screened materials, with Provectus operatives handpicking approximately 205kg of visible ACM (quantities provided by Provectus).

Hydrock's daily diary for this period is available in Appendix A

3.1.1 *Monday 4th September 2023*

The weather conditions were dry and hot, with temperatures reaching 22°C and wind speeds averaging 3mph, occasionally gusting up to 6mph. Provectus conducted water suppression activities before Hydrock's arrival on site and repeated the process after the slab sampling, which occurred at approximately 08:00 and 14:00, respectively.

Andy Stockton, Provectus STC Manager at Maw Green, confirmed via email that the total throughput for the processing operation on Monday, September 4th, was as follows:

- » Approximately 100 tonnes of soil were processed between 09:15 and 15:15.
- » Approximately 120kg of ACM (visible fragments) were removed in total between September 4th and 5th.
- » Andy estimated that approximately 60kg of ACM (visible fragments) were removed on the 4th of September.

3.1.2 *Tuesday 5th September 2023*

The weather conditions were dry and hot, with temperatures reaching 25.5°C and wind speeds between 3-11mph, occasionally gusting up to 18mph. Provectus conducted water suppression activities after Hydrock's slab sampling was complete at approximately 11:00.

Andy Stockton (Provectus STC Manager - Maw Green) confirmed via email that the total throughput for the processing operation on Tuesday 5th of September was:

- » Approximately 100 tonnes of soil processed between 09:15 to 15:15; with

- » Approximately 120kg of ACM (visible fragments) were removed in total between the 4th and 5th of September. Andy Stockton estimates this equates to approximately 60kg of ACM (visible fragments) removed per day.
- » Andy estimates this equated to approximately 60kg of ACM (visible fragments) removed on the 5th of September.

3.1.3 Wednesday 6th September 2023

The weather was dry and hot, with temperatures reaching up to 23.8°C. Wind speeds averaged between 3-4mph, occasionally gusting between 3-12mph. Water suppression was conducted by Provectus after Hydrock's slab sampling was completed at approximately 11:15.

Andy Stockton, Provectus STC Manager at Maw Green, confirmed via email the total throughput for the processing operation on Wednesday, September 6th, as follows:

- » Approximately 100 tonnes of soil were processed between 09:30 and 15:30.
- » Approximately 50kg of ACM (visible fragments) were removed in total.

3.1.4 Thursday 7th September 2023

The weather conditions were dry and hot, with temperatures exceeding 19.6°C. Wind speeds were around 1mph, occasionally gusting to 3mph. Water suppression was conducted by Provectus after Hydrock's slab sampling was completed at approximately 11:30.

Andy Stockton, Provectus STC Manager at Maw Green, confirmed via email the total throughput for the processing operation on Thursday, September 7th, as follows:

- » Approximately 80 tonnes of soil were processed between 09:00 and 15:00.
- » Approximately 35kg of ACM (visible fragments) were removed in total.

3.2 Weather data

Weather data was collected from the on-site 'Skyview' monitoring station, each morning prior to Hydrock undertaking any sampling and again after sampling, if there had been significant change.

Table 3.1: Onsite weather station data Monday 4th September 2023

Monday 4 th September 2023		
Weather Details	Time Taken	10:14
	Wind Direction	SSE
	Wind Speed (mph)	3
	Gust Speed (mph)	6
	Pressure (mb)	1022.3
	Temperature (°C)	22.0
	Humidity (%)	81
	Dew Point (°C)	17.7
Other	No rain overnight Details taken from onsite Skyview monitoring station	

Table 3.2: Onsite weather station data Tuesday 5th September 2023

Tuesday 5th September 2023		
Weather Details	Time Taken	08:38
	Wind Direction	S
	Wind Speed (mph)	1
	Gust Speed (mph)	3
	Pressure (mb)	1020.8
	Temperature (°C)	17.4
	Humidity (%)	-
	Dew Point (°C)	17.0
	Other	No rain overnight Details taken from onsite Skyview monitoring station
Weather Details	Time Taken	12:45
	Wind Direction	-
	Wind Speed (mph)	11
	Gust Speed (mph)	18
	Pressure (mb)	-
	Temperature (°C)	25.4
	Humidity (%)	46
	Dew Point (°C)	26
	Other	No rain overnight Details taken from onsite Skyview monitoring station and local forecasts

Table 3.3: Onsite weather station data Wednesday 6th September 2023

Wednesday 6th September 2023		
Weather Details	Time Taken	08:30
	Wind Direction	SSE
	Wind Speed (mph)	3
	Gust Speed (mph)	3
	Pressure (mb)	1020.8
	Temperature (°C)	16.9
	Humidity (%)	50

Weather Details	Dew Point (°C)	-
	Other	No rain overnight Details taken from onsite Skyview monitoring station
	Time Taken	12:30
	Wind Direction	SSW
	Wind Speed (mph)	4
	Gust Speed (mph)	12
	Pressure (mb)	1021
	Temperature (°C)	23.8
	Humidity (%)	73
	Dew Point (°C)	-
Other	Details taken from onsite Skyview monitoring station	

Table 3.4: Onsite weather station data Thursday 7th September 2023

Thursday 7th September 2023		
Weather Details	Time Taken	08:15
	Wind Direction	SE
	Wind Speed (mph)	1
	Gust Speed (mph)	3
	Pressure (mb)	1017.4
	Temperature (°C)	19.6
	Humidity (%)	93
	Dew Point (°C)	-
	Other	Light rain overnight however none recorded on Skyview. Details taken from onsite Skyview monitoring station

3.3 DustTrak data

DustTrack summary data is presented in Appendix G – Tables F1 to F4. Details of the instrument used is provided in Table 3.5 and the calibration certification is provided in Fig 1 in Appendix G.

Full DustTrack data can be provided in excel format upon request.

Table 3.5: DustTrack instrument data

Criteria	Detail
Instrument Name	DustTrak DRX
Model Number	8534
Serial Number	8534174005
Firmware Version	3.7
Calibration Date	16/06/2023

4. Sampling Methods

The soil sampling methods adhered to Hydrock's internal standard procedures, specifically 'FP004 – Sampling of Asbestos in Soil,' revision 0, dated July 21, 2023. A copy of the field procedure is included in Appendix C.

Samples of the pre-screened material were collected at random intervals from the excavator bucket over an approximate 3-hour period each day. Simultaneously, samples of the fine materials were obtained at the same intervals from the fines stockpile directly from the processor.

Composite sampling locations for the 'slab samples' are illustrated in annotated photographs 9, 19, 25, and 23, which can be found in Appendix B.

5. Summary of Results

5.1 Dets

Hydrock obtained a total of 24 soil samples for analysis by Dets. Further details of the samples locations, dates and analysis results are presented in Table 5.1 below.

Copies of the laboratory certification are presented in Appendix F.

Table 5.1: Sampling details

Sample Ref. Number*	Location	Asbestos Screen	Respirable Fibre (f/mg)
Sample date: Monday 4th September 2023			
SP/PS/4.9.23/-1	Pre-screen stockpile	Chrysotile present as fibre bundles	19200.000
SP/PS/4.9.23/-2	Pre-screen stockpile	Chrysotile present as fibre bundles	28100.000
SP/F/4.9.23/-1	Post-screen stockpile (Fines)	Chrysotile present as fibre bundles	20400.000
SP/F/4.9.23/-2	Post-screen stockpile (Fines)	Chrysotile present as fibre bundles	17900.000
SLAB/F/4.9.23/-1	Concrete slab	Chrysotile present as fibre bundles	38300.000
SLAB/F/4.9.23/-2	Concrete slab	Chrysotile present as fibre bundles	21700.000

Sample date: Tuesday 5th September 2023

SP/PS/5.9.23/-1	Pre-screen stockpile	Amosite present as fibre bundles	12800.000
SP/PS/5.9.23/-2	Pre-screen stockpile	Chrysotile present as fibre bundles	24300.000
SP/F/5.9.23/-1	Post-screen stockpile (Fines)	Amosite present as fibre bundles	26800.000
SP/F/5.9.23/-2	Post-screen stockpile (Fines)	Chrysotile present as fibre bundles	29400.000
SLAB/F/5.9.23/-1	Concrete slab	Chrysotile present in microscopic cement fragment	29400.000
SLAB/F/5.9.23/-2	Concrete slab	Chrysotile present as fibre bundles	12800.000

Sample date: Wednesday 6th September 2023

SP/PS/6.9.23/-1	Pre-screen stockpile	Bundle of Chrysotile fibres	23000.000
SP/PS/6.9.23/-2	Pre-screen stockpile	Not Detected	25500.000
SP/F/6.9.23/-1	Post-screen stockpile (Fines)	Not Detected	5110.000
SP/F/6.9.23/-2	Post-screen stockpile (Fines)	Bundle of Chrysotile fibres	16600.000
SLAB/F/6.9.23/-1	Concrete slab	Not Detected	21700.000
SLAB/F/6.9.23/-2	Concrete slab	Bundle of Chrysotile fibres	12800.000

Sample date: Thursday 7th September 2023

SP/PS/7.9.23/-1	Pre-screen stockpile	Not Detected	12800.000
SP/PS/7.9.23/-2	Pre-screen stockpile	Not Detected	7660.000
SP/F/7.9.23/-1	Post-screen stockpile (Fines)	Bundle of Chrysotile fibres	5110.000
SP/F/7.9.23/-2	Post-screen stockpile (Fines)	Bundle of Chrysotile fibres	6390.000
SLAB/F/7.9.23/-1	Concrete slab	Chrysotile present in microscopic cement debris	12800.000
SLAB/F/7.9.23/-2	Concrete slab	Chrysotile present in microscopic cement debris	35800.000

5.2 Lucion

In accordance with the scope of work, Lucion collected twelve samples over a three-day period between September 4th and 6th, 2023. Sampling locations were as follows, with samples collected each day:

- » One upwind sample, approximately 50m from the main processing area.
- » One downwind sample directly adjacent to the main processing area.
- » One downwind sample, approximately 50m from the main processing area.
- » One downwind sample, approximately 100m from the main processing area.

All air monitoring took place following a period of dry, settled weather conditions. Lucion was unable to be on-site on Thursday, September 7th. Thames Laboratory fulfilled the scope for the final day of sample collection, and SEM analysis was conducted by IOM Laboratories. Details regarding the fourth day of SEM monitoring are provided in Section 5.3.

Results of the Lucion SEM monitoring are presented in Table 5.2 below. The full Lucion report including daily diaries, field sample collection information, SEM data, calibration and training records is presented in Appendix D.

Table 5.2: Lucion SEM results

Job number & Sample Number	Sampled air volume	Respirable fibres*	No of fields searched	Total fibre concen.	Asbestos fibre concn.	Detection limit based on 95% confidence (f/ml)	Reported result (conc. f/ml)
593515-1-1	3838	1.5	240	0.0001	0.0000	0.00003	<0.00003
593515-1-2	3813	0	240	0.0000	0.0000	0.00003	<0.00003
593515-1-3	3720	1	240	0.0000	0.0000	0.00004	<0.00004
593515-2-1	3292	2.5	240	0.0001	0.0000	0.00005	<0.00005
593515-3-1	3751	0	240	0.0000	0.0000	0.00004	<0.00004
593515-3-2	3751	1	240	0.0000	0.0000	0.00004	<0.00004
593515-3-3	3751	0	240	0.0000	0.0000	0.00004	<0.00004
593515-4-1	3751	1.5	240	0.0001	0.0000	0.00004	<0.00004
593515-5-1	3736	0	240	0.0000	0.0000	0.00004	<0.00004
593515-5-2	3766	0	240	0.0000	0.0000	0.00003	<0.00003
593515-5-3	3751	0	240	0.0000	0.0000	0.00004	<0.00004
593515-6-1	3751	0	240	0.0000	0.0000	0.00004	<0.00004

For all twelve samples collected zero Amphibole or Chrysotile fibres were found, and therefore the reported total asbestos fibre concentration is recorded as between 0.00003 f/ml and 0.00005 f/ml for all samples taken.

Detection limit is reported as the numerical fibre concentration below which, with 95% probability, the actual concentration lies when no fibres are detected. Detection limit depends on sampled volume of air and the examined filter area. Detection limit is determined in accordance with ISO14966.

5.3 Thames Laboratories/IOM

Four samples were collected by Thames Laboratory in the 7th of September 2023. Sampling locations were collected from the following locations:

- » One upwind sample approximately 50m of the main processing area;
- » One downwind sample directly adjacent to the main processing area;
- » One downwind sample approximately 50m of the main processing area; and
- » One downwind sample approximately 100m of the main processing area;

All air monitoring was undertaken following a period of dry, settled weather conditions.

Results of the Thames Laboratory/IOM monitoring are presented in Table 5.3 below. The Thames Laboratory/IOM results are presented in Appendix E. Thames Laboratory did not provide a separate report and for the fourth day and therefore details on daily diaries, field sample collection information, SEM data, calibration and training records is not present.

Table 5.3: IOM SEM results

Sample No.	Volume (l)	No. of Resp. Fibres Found	No. of Fields Searched	Total Fibres Fibre Conc (fml-1)	AMX Fibre No. of Resp. Fibres/Fibre Conc (fml-1)	CMX Fibre No. of Resp. Fibres/Fibre Conc (fml-1)	MMMF No. of Resp. Fibres/Fibre Conc (fml-1)	NAM Fibre No. of Resp. Fibres/Fibre Conc (fml-1)
J267581 IH674	3720	2.5	600	<0.00005*	0/<0.00005*	0/<0.00005*	2.5/<0.00005*	0/<0.00005*
J267581 IH675	3720	1	600	<0.00005*	0/<0.00005*	0/<0.00005*	0/<0.00005*	1/<0.00005*
J267581 IH676	3720	3	600	0.00005	0/<0.00005*	0/<0.00005*	3/<0.00005*	0/<0.00005*
J267581 IH677	3720	2	600	<0.00005*	1 / <0.00005*	0/<0.00005*	0/<0.00005*	1/<0.00005*

NB. AMX-Amphibole Asbestos CMX-Chrysotile Asbestos MMMF-Machine Made Mineral Fibres NAM-Non-Asbestos Mineral

* DETECTION LIMIT

Appendix A - Hydrock Daily Diaries

DAILY DIARY

Project: Maw Green	Date: 04.09.2023
Client: FCC&P	Engineer: Becky Homer
Contract No.: 28480	

Weather Details:	
Time Taken	10:14
Wind Direction	SSE
Wind Speed (mph)	3
Gust Speed (mph)	6
Pressure (mb)	1022.3
Temperature (°C)	22.0
Humidity (%)	81
Dew Point (°C)	17.7
Other	No rain overnight Details taken from onsite Skyview monitoring station

Site Activities:
<ul style="list-style-type: none"> Six samples taken by Hydrock engineer; 2x samples from concrete slab, 2x samples from pre-screened stockpile and 2x samples from post-screened (fines) stockpile. Samples taken during active processing by Provectus between 10:30am and 14:00pm. Asbestos in air samples taken by Lucion engineer; one upwind, two downwind and one adjacent to processing area, 11 dust monitoring readings taken; at locations adjacent to air monitoring stations in both morning and afternoon and additional reading in site cabin. Water/dust suppression completed at 8:00am and after slab sampling completed.

DAILY DIARY



DAILY DIARY

Project: Maw Green	Date: 05.09.2023
Client: FCC&P	Engineer: Becky Homer
Contract No.: 28480	

Weather Details:	
Time Taken	08:38
Wind Direction	S
Wind Speed (mph)	1
Gust Speed (mph)	3
Pressure (mb)	1020.8
Temperature (°C)	17.4
Humidity (%)	-
Dew Point (°C)	17.0
Other	No rain overnight Details taken from onsite Skyview monitoring station
Time Taken	12:45
Wind Direction	-
Wind Speed (mph)	11
Gust Speed (mph)	18
Pressure (mb)	-
Temperature (°C)	25.4
Humidity (%)	46
Dew Point (°C)	26
Other	No rain overnight Details taken from onsite Skyview monitoring station and local forecasts

DAILY DIARY

Site Activities:

- Six samples taken by Hydrock engineer; 2x samples from concrete slab (09:20am) 2x samples from pre-screened stockpile and 2x samples from post-screened (fines) stockpile (09:30-10:00 and 11:00-11:45)
- Samples taken during active processing by Provectus between 08:45am and 13:00pm.
- Asbestos in air samples taken by Lucion engineer; one upwind, two downwind and one adjacent to processing area.
- 6 dust monitoring readings taken; at locations adjacent to air monitoring stations in both morning and afternoon and additional reading in site cabin.
- Water/dust suppression completed at 11:00am.



DAILY DIARY



DAILY DIARY

Project: Maw Green	Date: 06.09.2023
Client: FCC&P	Engineer: Becky Homer
Contract No.: 28480	

Weather Details:	
Time Taken	08:30
Wind Direction	SSE
Wind Speed (mph)	3
Gust Speed (mph)	3
Pressure (mb)	1020.8
Temperature (°C)	16.9
Humidity (%)	50
Dew Point (°C)	-
Other	No rain overnight Details taken from onsite Skyview monitoring station
Time Taken	12:30
Wind Direction	SSW
Wind Speed (mph)	4
Gust Speed (mph)	12
Pressure (mb)	1021
Temperature (°C)	23.8
Humidity (%)	73
Dew Point (°C)	-
Other	Details taken from onsite Skyview monitoring station

DAILY DIARY

Site Activities:

- Six samples taken by Hydrock engineer; 2x samples from concrete slab 2x samples from pre-screened stockpile and 2x samples from post-screened (fines) stockpile.
- Samples taken during active processing by Provectus between 08:30 and 13:00.
- Asbestos in air samples taken by Lucion engineer; one upwind, two downwind and one adjacent to processing area.
- 7 dust monitoring readings taken; at locations adjacent to air monitoring stations in both morning and afternoon and additional reading in site cabin.
- Water/dust suppression completed at 11:15am.



DAILY DIARY



DAILY DIARY

Project: Maw Green	Date: 07.09.2023
Client: FCC&P	Engineer: Becky Homer
Contract No.: 28480	

Weather Details:	
Time Taken	08:15
Wind Direction	SE
Wind Speed (mph)	1
Gust Speed (mph)	3
Pressure (mb)	1017.4
Temperature (°C)	19.6
Humidity (%)	93
Dew Point (°C)	-
Other	Light rain overnight however none recorded on Skyview. Details taken from onsite Skyview monitoring station

Site Activities:
<ul style="list-style-type: none"> Six samples taken by Hydrock engineer; 2x samples from concrete slab 2x samples from pre-screened stockpile and 2x samples from post-screened (fines) stockpile. Samples taken during active processing by Provectus between 08:30 and 13:00. Asbestos in air samples taken by Lucion engineer; one upwind, two downwind and one adjacent to processing area, 6 dust monitoring readings taken; at locations adjacent to air monitoring stations in both morning and afternoon and additional reading in site cabin. Water/dust suppression completed at approx. 11:30am.

DAILY DIARY



Appendix B - Photographs



Photograph 1 – 04/09/23 Processing area setup (picking line to the left)



Photograph 2 – 04/09/23 Site overview



Photograph 3 – 04/09/23 pre-screened material stockpile

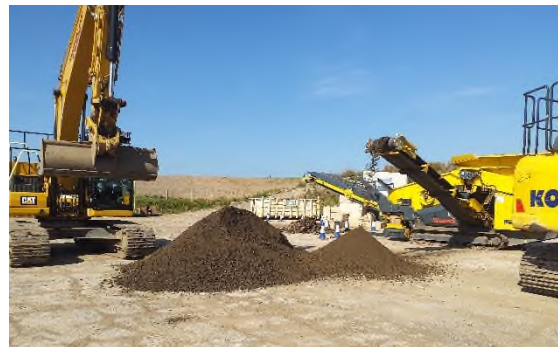

Photograph 4 – 04/09/23 Fines stockpile



Photograph 5 – 04/09/23 Dust/debris to slab for sampling A



Photograph 6 – 04/09/23 Dust/debris to slab for sampling B



Photograph 7 – 04/09/23 Picking line setup



Photograph 8 – 04/09/23 End of the day clean up (@17:55)



Photograph 9 – 04/09/23 Slab sampling locations



Photograph 10 – 04/09/23 50m SEM Sample point (Downwind)



Photograph 11 – 04/09/23 100m SEM Sample point (Downwind)



Photograph 12 – 05/09/23 Site setup

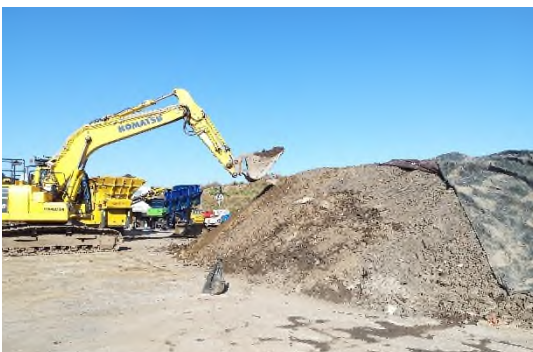

Photograph 13 – 05/09/23 pre-screened material stockpile



Photograph 14 – 05/09/23 processed fines



Photograph 15 – 05/09/23 50m SEM Sample point (Downwind)



Photograph 16 – 05/09/23 100m SEM Sample point (Downwind)



Photograph 17 – 05/09/23 Adjacent SEM Sample point (Downwind)



Photograph 18 – 05/09/23 50m SEM Sample point (Upwind)



Photograph 19 – 05/09/23 Slab sampling locations



Photograph 20 – 06/09/23 pre-screened material stockpile



Photograph 21 - 06/09/23 Fines stockpile



Photograph 22 – 06/09/23 50m SEM Sample point (Downwind)



Photograph 23 – 06/09/23 100m SEM Sample point (Downwind)



Photograph 23 – 06/09/23 Adjacent SEM Sample point (Downwind)



Photograph 24 – 06/09/23 50m SEM Sample point (Upwind)



Photograph 25 – 06/09/23 Slab sampling locations



Photograph 26 – 07/09/23 pre-screened material stockpile



Photograph 27 – 07/09/23 Fines stockpile



Photograph 28 – 07/09/23 50m SEM Sample point (Downwind)



Photograph 29 – 07/09/23 100m SEM Sample point (Downwind)



Photograph 30 – 07/09/23 Adjacent SEM Sample point (Downwind)



Photograph 31 – 07/09/23 50m SEM Sample point (Upwind)



Photograph 32 – 07/09/23 Slab sampling locations

Appendix C – Hydrock Asbestos in Soil Sampling procedure

GEO Field Procedure for Sampling of Asbestos in Soil

Field procedure title	Sampling of Asbestos in Soil		
Document reference	FP004		
Author	Simon Cole		
Revision	0		
Date	21 July 2023	Approved	✓

1. Purpose and Scope

This document describes the standard field procedure used by Hydrock for sampling asbestos in soil, Made Ground or construction and demolition materials which are known to contain asbestos containing materials, and the work is classified as Non-Licensed under the Control of Asbestos Regulations (CAR) 2012. In order to determine the licensing status of the proposed work, a work category risk assessment in accordance with prevailing UK best practice as described by the CL:AIRE/JIWG CAR-SOIL™ guidance¹ should be undertaken and reported in the associated RAMS for this work.

All work must be undertaken in accordance with the requirements of the project-specific health and safety documents, including the Method Statement and Risk Assessment, and the Construction Phase Plan.

The key objectives of sampling are:

- » to obtain samples of material that are representative of conditions encountered; and
- » to minimise the potential release of asbestos fibres during sample collection and handling.

Additional requirements apply relating to equipment, clothing and procedures to avoid cross-contamination when sampling soils containing (or suspected to contain) asbestos. Hydrock provides specific training and more detailed procedures that apply when sampling for asbestos. Please refer to the Project Director or Manager for more information.

This procedure does not cover sampling of material where there is a low potential that asbestos is present but has not been proven (i.e. where normal sampling procedures are appropriate). Nor does it cover procedures for work which is licensed. If the conditions encountered during the works are different to what is anticipated and may form licensed work, then all work must be stopped and the Project Manager notified.

2. Training Requirements

Works described in this procedure should only be completed by field staff and/or subcontractors that have been trained by a competent trainer and their training verified. Staff must hold relevant non-licensed work training prior to undertaking the tasks described in this procedure.

¹ [Asbestos in Soil \(claire.co.uk\)](https://www.claire.co.uk)

3. Selecting Sampling Approach

Soil sampling for suspected or identified asbestos is typically undertaken under two circumstances; firstly, for the assessment of potential land contamination, and secondly, for waste characterisation and classification. The first requires discrete sampling, the second requires composite sampling.

Key considerations:

- » Sample size. Laboratories will ordinarily require a 500g to 1kg plastic tub to be filled to enable laboratory analysis. This is ok if only dispersed asbestos fibres, fibre bundles and very small fragments of ACM are present in the material. A different strategy is required if larger ACM fragments are present. Do not pick up a visible piece of ACM, place in the sample tub and then simply fill the remainder of the tub with soil. This will not be a representative of the material/soil being sampled. Where visible fragments are present, follow the sampling protocol published by SoBRA which requires an initially larger 10 litre sample to be visually inspected on site to count, size, and weigh ACM fragments, and then a 500g-1kg sub-sample of the finer material taken for laboratory analysis.
- » Sample frequency: For site characterisation purposes, discrete samples can be taken in accordance with a BS10175-compliant sampling plan as per other contaminants. For stockpiled material (of particular relevance for waste characterisation and classification) composite samples should be taken on a minimum frequency as set out [here](#).

4. Standard Procedure

4.1 Planning

Step 1: Confirm sampling plan with the Project Manager.

Step 2: Review available site information and undertake a work category risk assessment to determine the licensing status of the works. Make sure you understand anticipated ground conditions, and likely types and forms of asbestos present. The Field Engineer is responsible for knowing what to expect at the site and being able to recognise and react if unusual/inconsistent conditions are encountered on site.

Step 3: Discuss works with the Project Manager and confirm training needs for task.

Step 4: Establish required method for collection, handling, storage and disposal of asbestos contaminated materials and equipment (as required).

Step 5: Ensure that all arrangements are in place for personal (and environmental if required) monitoring as set out in the RAMS.

Step 6: Confirm decontamination procedure and requirements. Consideration should be given to areas for putting on and removing PPE and RPE, work area set up, use of sheeting for spoil to prevent cross-contamination, and decontamination areas at each sampling location.

Step 7: Make sure all required field equipment is available and in good working order before arriving at site.

4.2 Sampling

Step 8: Walkover survey. The work area should be subject to a walkover survey by someone suitably experienced and trained (if not already carried out). The Plan of Work should be adjusted accordingly if the condition of the land is markedly different to that anticipated.

Step 9: Damping down. For surface / stockpile sampling, if soil is dry and dusty, dampen it with a handheld water mister/sprayer (such as a horticultural 5 litre pump action pressure sprayer) prior to sampling to minimise airborne fibre release. Water should contain a wetting agent (such as biodegradable washing up liquid or Decon90) if amphibole asbestos is (or is suspected of being) present.

If large plant or equipment, such as drilling rigs, or excavators are being used to obtain samples, damping down should be achieved in accordance with the RAMS. This should stipulate the use of hand-held hoses, and/or commercially available air misters that are capable of damping down the entire work area.

Step 10: Sampling. Sampling should be undertaken from material retrieved from a trial pit or sub sampled from a drilling core or taken directly from stockpiled material using a clean stainless-steel trowel whilst wearing appropriate PPE as defined in the RAMS (this should typically include disposable coveralls, nitrile gloves, and respiratory protection with P3 filter [if required]). The samples should be placed in laboratory provided containers suitable for the testing required. Where ACM fragments are observed either at surface or in disturbed soil destined for sampling, these should be carefully picked out and double bagged separately in accordance with HSE EM9. A record should be kept of the estimated area and volume of material to which the ACM was a part of. The fragment should be sent for laboratory analysis in addition to the soil sample.

Step 11: Management of sampling spoil. Spoil should be placed such that it does not contaminate adjacent soil with asbestos. This will only be relevant for evident hotspots of asbestos contamination and should be mitigated by the use of disposable sheeting to hold the spoil temporarily prior to replacement in the ground from where it originated. Spoil should not be allowed to dry out and should be dampened periodically to minimise airborne fibre release if replacement is delayed for any reason.

Step 12: Sample packaging, labelling and storage. All packaging used to transport asbestos containing materials must be designed to reduce the risk of release of asbestos material or asbestos fibres during transit, (e.g. double bagging of samples). Each sample should be photographed and have a written field record of visual observations on characteristics of suspected ACM identified. Soil samples must be labelled such that subsequent handlers of that sample are aware of the potential presence of asbestos in the samples. The laboratory chain of custody form and the sample container should be labelled with "may contain asbestos". Sample cool boxes for courier transport should not be labelled on the outside of the box as containing asbestos. Store samples in accordance with laboratory instructions, and in accordance with HSE EM9 where appropriate.

Step 13: Chain of custody. A chain-of-custody form must be kept with the samples, recording the sample type, sampling time, date and required analysis. This form should also be used to record the handover of the samples. All samples should be transferred by same-day or overnight courier to the laboratory (generally within 24 hours of sampling if volatile chemicals are being tested for) in the sealed insulated cool boxes.

Step 14: Decontamination. Hand sampling equipment should be carefully wiped down with disposable damp cloths as per HSE EM7. If large plant or equipment, as above, are being used to obtain samples, there must be a sufficient procedure in place for decontamination. This should include a dedicated area for jet washing and/or wheel washing. Personal decontamination should be in accordance with NLW training procedure and include removal of disposable clothing (coveralls and gloves) in reverse (i.e. in side out) and P3 dusk masks/respirator with P3 filter, and then cleaning boots using water and a brush. Re-usable RPE should be cleaned with disposable damp cloths and returned to its storage bag/case.

Step 15: Waste handling. All disposable PPE, RPE and sampling waste potentially contaminated with asbestos is to be separated from other uncontaminated wastes and securely bagged, labelled, stored, and disposed of in accordance with HSE EM9.

Step 16: Record of sample location. Photograph sample location and record GPS co-ordinates

4.3 QA/QC Samples

QA/QC samples must be kept with the primary samples while on site and during transport to the laboratory. The only relevant QA/QC sample type for soil sampling is field duplicate. Field duplicate samples should be collected in the same manner and at the same time as the primary samples. The requirement for duplicate samples

Refer to the separate Hydrock Technical Note on sample and laboratory QA/QC.

4.4 Terms and Definitions

AiS: Asbestos in soil (also covers asbestos in Made Ground and construction demolition materials in this context)

Asbestos: Any of six fibrous silicate minerals: chrysotile, amosite, crocidolite, anthophyllite, tremolite, and actinolite regulated under the Control of Asbestos Regulations 2012

Trace: More than 2 fibres detected as per HSG248 method. Practical limit of detection for soil is 0.0001%wt/wt (1mg/kg) = trace. Practical limit of quantification for soil is 0.001%wt/wt (10mg/kg) – may be trace if only occasional/sporadic and random ACMs present based on a suitable and sufficient investigation

ACM: Asbestos containing material (for example asbestos cement sheeting, asbestos insulation board, or asbestos-reinforced plastic or resin)

RAMS: Task-specific risk assessment and method statement. This field procedure can form part of or be the method statement subject to the specific plan of work

HSE EM7: Health and Safety Executive asbestos essentials guidance on using damp rags to clean surfaces of minor asbestos contamination [em7.pdf \(hse.gov.uk\)](#)

HSE EM9: Health and Safety Executive asbestos essentials guidance on disposal of asbestos waste [em9.pdf \(hse.gov.uk\)](#)

PPE: Personal protective equipment

RPE: Respiratory protective equipment

5. References

CL:AIRE, 2016. Control of Asbestos Regulations 2012 - Interpretation for Managing and Working with Asbestos in Soil and Construction and Demolition Materials: Industry guidance. CL:AIRE, London. ISBN 978-1-905046-30-0

6. Records

Photolog

Trial pit log

Borehole log

Laboratory chain of custody

7. Attachments

Attachment 1 – Composite sampling approach for stockpiles

Attachment 2 – Sampling of dusts

8. Revision No.

Rev #	Change Date	Description of Change	Location of Change

ATTACHMENT 1

Composite Sampling Approach for Stockpiles

This approach is based on Appendix D of Environment Agency WM3², ISO 10381-8:2006³, and Environment Agency on-line guidance on disposal of waste to landfill (last updated 29 June 2023)⁴.

EA (2023) outlines the following sampling frequencies for minimum laboratory testing for basic waste characterisation:

Amount of waste (tonnes)	Homogeneous waste (number of samples)	Heterogeneous and new waste (number of samples)
Less than 100 t	2	5
100 to 500 t	3	8
500 to 1,000 t	5	14
1,000 to 10,000 t	11	22
Plus (per additional) 10,000 t	+5 (pro rata)	+10 (pro rata)

Composite samples should be comprised of 10 incremental samples taken in a systematic pattern across the stockpile. If the laboratory sample size is 1kg, each increment should be 100g. To minimise sample handling it is not advocated that asbestos contaminated soil sample increments are taken as oversize samples and subsequently reduced in volume using cone and quartering to provide the final composite sample for laboratory testing.

Further calculations to determine sample size are not required unless material is particularly coarse in its particle size distribution.

Approximate stockpile volumes can be calculated as follows:

For conical stockpiles:

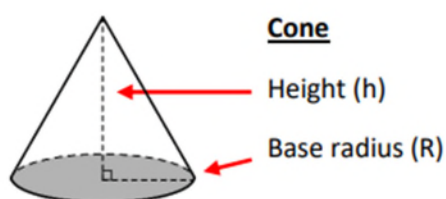

Formula to calculate the volume of a cone:

$$V = \frac{1}{3} \pi R^2 h$$

Where:

$$V = \text{Volume} \quad \pi = \text{pi (3.14159)}$$

$$R^2 = \text{Radius x Radius} \quad h = \text{Height}$$

² Environment Agency, 2021. Waste Classification. Guidance on the classification and assessment of waste (1st edition v1.2.GB). Technical Guidance WM3, Environment Agency, Bristol, October 2021

³ ISO 10381-8:2006. Soil Quality – sampling – Part 8: Guidance on sampling of stockpiles.

⁴ [Dispose of waste to landfill - GOV.UK \(www.gov.uk\)](https://www.gov.uk/government/guidance/dispose-of-waste-to-landfill)

Base diameter (m)	Height (m)				
	1	2	3	4	5
	Volume (m ³)				
2	1	2	3	4	5
3	2	5	7	9	12
4	4	8	13	17	21
5	7	13	20	26	33
10	26	52	79	105	131

For elongated stockpiles:

Width (m)	Height (m)				
	1	2	3	4	5
	Volume per unit length (m ³ /m)				
2	1	3	4	5	7
3	2	4	6	8	10
4	3	5	8	11	13
5	3	7	10	13	17
10	7	13	20	27	33

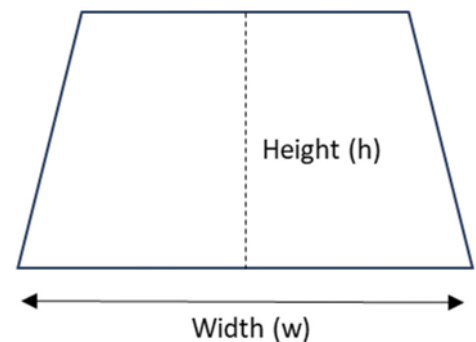

The above calculation assumes the stockpile cross-sectional area is in between that for a triangle and a rectangle (approx. 2/3rds of the latter).

The sampling pattern required (including depth of samples) will be dependent on the size of the stockpile. For small stockpiles, incremental samples can be taken by hand using a hand-held trowel or spade. For larger stockpiles, trial pitting techniques will be required to extract material from sufficient depth within the stockpile.

An example sampling pattern is illustrated below (reproduced from ISO 10381-8:2006 Figure 4 – example of the definition of a systematic sampling pattern on a soil stockpile):

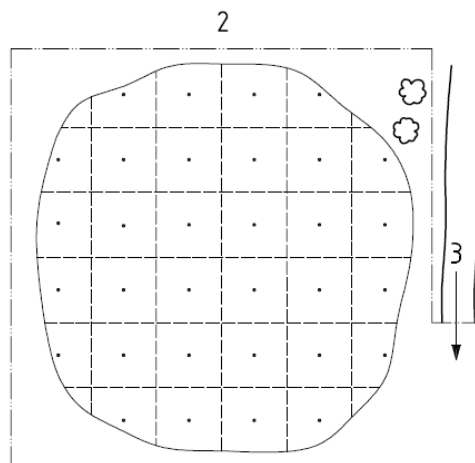
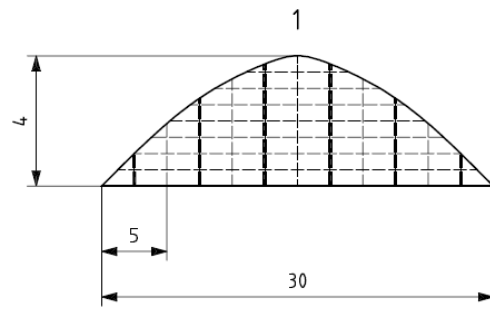

ATTACHMENT 2

Sampling of roadway, track and hardstanding slab dusts

To sample dust deposition on roadways, tracks or hardstanding slabs supplement the procedure outlined for soil sampling with the following:

1. Determine the number of samples required based on the extent of surfacing requiring sampling. Assuming a 0.5mm thickness of dust, a 1 litre sample will require a swept area of 2m².
2. Determine the area of surfacing that will need to be swept to provide the sample size required for laboratory testing. The sample areas should ideally be square areas that can be measured, and surveyed for delineation on a sampling plan.
3. Damping down is critical as the need to sweep the dust using a hand-held brush will inherently generate more dust than comparable soil sampling. Dust surface needs to be very lightly misted using a hand-held sprayer. If too wet the dust will clog in the brush.
4. Use a long-handled brush to collect the dust sample so that the breathing zone of the operative is as far away from the dust surface as possible (i.e. as opposed to using a short-handled dustpan-type brush).
5. Use a dust-pan and brush to collect the brushed dust and fill the required sample container.
6. Thoroughly decontaminate the brushes in between samples using soapy water. Brushes will need to be dried before collecting the next sample to avoid the dust clogging the brush bristles.

Appendix D - Lucion Summary Report (inc. SEM Results)



Asbestos Air Monitoring Review

Maw Green Soil Treatment Works



Maw Green Road, Crewe CW1 5NG

NexGen Contract ID:	99022	NexGen Job ID:	598514
Revision:	0.3	Client Project ID (if applicable):	28480
Document Author:	David Grunnill		
Document Reviewed By:	Richard Marshall		
Report Issue Date:	25/10/2023		

Introduction

Site Name

Maw Green Soil Treatment Works, Maw Green Road, Crewe, CW1 5NG

Background

FCC/Provectus Environment (FCC&P) is currently considering an appeal against the Environment Agency's decision to partially refuse FCC's submission for a variation to its Environmental Permit.

To aid the appeal, FCC&P requested that Hydrock Consultants Ltd undertake a counter sampling exercise at the treatment facility at Maw Green Rd, Crewe CW1 5NG.

Lucion Services were appointed by Hydrock to undertake air monitoring and subsequent SEM analysis of the samples collected to determine whether airborne asbestos fibres are present, and the asbestos fibre concentration. The air monitoring and analysis were to be undertaken using a methodology to achieve a limit of detection of 0.00005 f/ml

Table of Contents

1.0 Project Particulars	4
2.0 Asbestos In Soils - Air Monitoring	5
2.1 Sampling Methodology	5
2.2 Sampling Strategy	5
2.3 Results	6
3.0 Conclusion	7
Appendix A - Sample Results	8
Appendix B - Job Summary Report and Analytical Certificates	21
Appendix C - SEM Asbestos Fibre Counting Test Certificate	22
Appendix D - SEM Microscope Certificate	23
Appendix E - Calibration Certificates	24
Appendix F - Lucion Technical Operating Procedures	25
Appendix G - Lucion Staff Qualifications	26

1.0 Project Particulars

Site Details:	Maw Green Soil Treatment Works, Maw Green Road, Crewe, CW1 5NG
Employer/ Client:	Hydrock Consultants Ltd Over Court Barns Over Lane Almondsbury Bristol BS32 4DF Contact: James Macfarlane (JamesMacfarlane@hydrock.com)
Asbestos Consultants:	Lucion Services Ltd Head Office: 7 Halifax Court, Dunston, Gateshead, NE11 9JT Contact: David Grunnill (david.grunnill@lucionservices.com)
Information source:	Lucion Services Asbestos Analyst's Job Summary Report Ref: 593515 Lucion Services Asbestos Analyst's Certificate Report Ref: 98739 dated 04/09/23 Lucion Services Asbestos Analyst's Certificate Report Ref: 98755 dated 05/09/23 Lucion Services Asbestos Analyst's Certificate Report Ref: 98771 dated 06/09/23 Lucion Services SEM Asbestos Fibre Counting Test Certificate dated 27/09/23

2.0 **Asbestos In Soils - Air Monitoring**

Report C733 (Asbestos in soil & made ground: a guide to understanding and managing risks) issued by CIRIA in 2014 states that “Where asbestos-containing soils (ACSs) are present, air monitoring data may be useful in supporting a robust soil risk assessment. However, the techniques and requirements may differ from those routinely used for occupational monitoring”

Occupational air monitoring using Phase Contrast Microscopy (PCM) is the method used for measuring airborne fibres (both asbestos and non asbestos) and is closely based on the World Health Organisation (WHO) method. This is the standard method for assessing whether or not an area is fit for reoccupation following asbestos abatement works and has a limit of quantification of 0.01 fibres/ml (this is the lowest level that can be reliably measured down to using PCM)

However, PCM is not appropriate for the measurement of long term environmental exposure, or ambient airborne fibre concentrations, as the methodology does not provide a detection limit close enough to the recognised ambient concentration of asbestos in air as 0.0001 fibres/ml or less.

In order to achieve a limit of detection (LOD) appropriate for measurement of low level ambient fibre concentrations, this requires a much higher volume of air to be sampled, followed by analysis using Scanning Electron Microscopy to produce an LOD less than (or equal to) 0.0001 fibres/ml.

2.1 **Sampling Methodology**

Samples were collected using an air monitoring pump set to a flow rate of 15 litres per minute (or higher) for a period of at least 214 minutes to give a minimum sampled volume of 3200 litres of air. All air monitoring is undertaken as per the procedures in Lucion Technical Operating procedure TOP02.02.08 *Procedure for Asbestos Air Sampling*.

The samples were subsequently analysed using the procedures outlined in the Lucion Technical Operating procedure TOP02.02.09.03 SEM *Procedure for identification and quantification of asbestos fibres on filter paper* for which Lucion holds UKAS accreditation.

This method is based upon ISO14966 (ISO 14966:2019 *Ambient air – Determination of numerical concentration of inorganic fibrous particles – Scanning electron microscopy method*) and includes initial ashing of the filters (all organic fibres are also destroyed) followed by analysis with Scanning Electron Microscopy at a magnification of 2.07kx.

For all samples collected, 240 fields were examined, which allows an LOD of 0.00005 f/ml or better to be achieved.

2.2 **Sampling Strategy**

Twelve samples were collected over a period of three consecutive days, with pumps being placed in the following locations each day:

- One sample close to the point source of potential airborne asbestos fibre positioned downwind of the source.
- One sample positioned 50 metres upwind of the source.
- Two samples located downwind of the source, positioned at 50 metres and 100 metres from the source.

Prior to positioning of the pumps, details of the current weather conditions were obtained from the on site weather station in order to determine where the pumps needed to be placed to ensure that down wind samples could be collected.

Sample numbers, and their approximate locations, are detailed on the following plan (sample numbers are indicated in yellow)



All air monitoring was undertaken following a period of dry, settled weather conditions. This is important as monitoring during wet weather would produce very low airborne fibre concentrations due to the soil moisture content..

As stated in CIRIA 733 *“There is limited data on the release of airborne fibres from soils in real environments, but it is generally agreed that soil moisture content has a particularly significant influence. In laboratory studies, the addition of five per cent moisture to a dry soil reduced airborne fibre release by 80 to 95 per cent and no airborne fibre were detected when the soil moisture content was greater than 15 per cent”*

The wind speed, wind direction, humidity, air temperature, atmospheric pressure and volume of rainfall were recorded during each day of air sampling.

2.3 Results

The results for each sample are detailed in Appendix A.

For each sample, the total number of respirable fibres, total fibre concentration, asbestos fibre concentration, detection limit and reported result is recorded.

For all twelve samples collected zero Amphibole or Chrysotile fibres were found, and therefore the reported total asbestos fibre concentration is recorded as between 0.00003 f/ml and 0.00005 f/ml for all samples taken.

The detection limit for each of the samples is between 0.00003 and 0.00005. It should be noted that the detection limit is recorded as the fibre concentration which, with 95% probability, the actual concentration lies when no fibres are detected within the sample. The calculated detection limit is based upon the sampled volume of air and the examined filter area.

For example, for a sample of 3720 litres where 240 fields are examined and no asbestos fibres are identified, there is a 95% confidence that the actual concentration is <0.00004 fibres/ml of air.

3.0 Conclusion

All air tests were undertaken using the standard Lucion Technical Operating Procedures for air sampling and scanning electron microscopy, for which Lucion holds UKAS accreditation.

Samples were collected as per the Scope and Requirements document (Ref 28480-HYD-XX-XX-FP-GE-003) and sampling plan issued by Hydrock Consultants.

Over the three consecutive days that air monitoring was undertaken, asbestos fibres were not identified within any of the samples collected.

Appendix A - Sample Results

Sample Number	593515-1-1	Date	04/09/23	Sample Type	Far source air test
Wind Direction	SSE	Wind Speed	3mpg, gust 6mph	Humidity	81
Pressure	1022.5	Temperature	21°	Rainfall	0mm
Sample Location	Positioned on a gantry above the tank in a NNW position, 50m upwind from the soil processing area				



Site Activity	Normal working conditions at time of air monitoring- diggers, earth mover machinery and pickers used on site.no dust suppression techniques utilised during the test.
----------------------	---

Time on (hh:mm)	Start Flow (l/min)	Time off (hh:mm)	End Flow (l/min)	Duration (minutes)	Sampled Volume (l)	Respirable Fibres	Fields Searched	Total Fibre Concentration	Asbestos Fibre Concentration	Detection Limit (f/ml)	Reported Result (f/ml)
10:30	15.5	14:35	15.5	245	3638	1.5	240	0.0001	0.0000	0.00003	<0.00003

Comments	No Amphibole or Chrysotile fibres identified
-----------------	--

Sample Number	593515-1-2	Date	04/09/23	Sample Type	Far source air test
Wind Direction	SSE	Wind Speed	3mpg, gust 6mph	Humidity	81
Pressure	1022.5	Temperature	21°	Rainfall	0mm
Sample Location	Positioned in a SSE direction adjacent to the lagoon, 50m downwind of the soil processing area				



Site Activity	Normal working conditions at time of air monitoring- diggers, earth mover machinery and pickers used on site.no dust suppression techniques utilised during the test.
----------------------	---

Time on (hh:mm)	Start Flow (l/min)	Time off (hh:mm)	End Flow (l/min)	Duration (minutes)	Sampled Volume (l)	Respirable Fibres	Fields Searched	Total Fibre Concentration	Asbestos Fibre Concentration	Detection Limit (f/ml)	Reported Result (f/ml)
10:45	15.5	14:51	15.5	246	3813	0	240	0.0000	0.0000	0.00003	<0.00003

Comments	No Amphibole or Chrysotile fibres identified
-----------------	--

Sample Number	593515-1-3	Date	04/09/23	Sample Type	Far source air test						
Wind Direction	SSE	Wind Speed	3mpg, gust 6mph			Humidity	81				
Pressure	1022.5	Temperature	21°		Rainfall	0mm					
Sample Location	Positioned adjacent to the gas pipework in a SSE position, 100m downwind of the soil processing area										
											
Site Activity	Normal working conditions at time of air monitoring- diggers, earth mover machinery and pickers used on site.no dust suppression techniques utilised during the test.										
Time on (hh:mm)	Start Flow (l/min)	Time off (hh:mm)	End Flow (l/min)	Duration (minutes)	Sampled Volume (l)	Respirable Fibres	Fields Searched	Total Fibre Concentration	Asbestos Fibre Concentration	Detection Limit (f/ml)	Reported Result (f/ml)
11:01	15.5	15:01	15.5	240	3720	1	240	0.0000	0.0000	0.00004	<0.00004
Comments	No Amphibole or Chrysotile fibres identified										

Sample Number	593515-2-1	Date	04/09/23	Sample Type	Near source air test
Wind Direction	SSE	Wind Speed	3mpg, gust 6mph	Humidity	81
Pressure	1022.5	Temperature	21.1°	Rainfall	0mm
Sample Location	Positioned adjacent to the soil processing picker machine (central point)				



Site Activity	Normal working conditions at time of air monitoring- diggers, earth mover machinery and pickers used on site.no dust suppression techniques utilised during the test.										
Time on (hh:mm)	Start Flow (l/min)	Time off (hh:mm)	End Flow (l/min)	Duration (minutes)	Sampled Volume (l)	Respirable Fibres	Fields Searched	Total Fibre Concentration	Asbestos Fibre Concentration	Detection Limit (f/ml)	Reported Result (f/ml)
10:40	15.1	14:18	15.1	218	3292	2.5	240	0.0000	0.0000	0.00005	<0.00005
Comments	No Amphibole or Chrysotile fibres identified										

Sample Number	593515-3-1	Date	05/09/23	Sample Type	Far source air test
Wind Direction	S / SSE	Wind Speed	1mph, gust 3mph	Humidity	49
Pressure	1019.3	Temperature	25.4°	Rainfall	0mm
Sample Location	Positioned adjacent to the road junction in a southern position, 50m upwind of the soil processing area				



Site Activity Normal working conditions at time of air monitoring- diggers, earth mover machinery and pickers used on site. Dust suppression techniques used on site due to conditions as within normal working procedures.

Time on (hh:mm)	Start Flow (l/min)	Time off (hh:mm)	End Flow (l/min)	Duration (minutes)	Sampled Volume (l)	Respirable Fibres	Fields Searched	Total Fibre Concentration	Asbestos Fibre Concentration	Detection Limit (f/ml)	Reported Result (f/ml)
09:55	15.5	13:57	15.5	242	3751	0	240	0.0000	0.0000	0.00004	<0.00004

Comments No Amphibole or Chrysotile fibres identified

Sample Number	593515-3-2	Date	05/09/23	Sample Type	Far source air test
Wind Direction	S / SSE	Wind Speed	1mph, gust 3mph	Humidity	49
Pressure	1019.3	Temperature	25.4°	Rainfall	0mm
Sample Location	Positioned 50m downwind of the soil processing area				



Site Activity Normal working conditions at time of air monitoring- diggers, earth mover machinery and pickers used on site. Dust suppression techniques used on site due to conditions as within normal working procedures.

Time on (hh:mm)	Start Flow (l/min)	Time off (hh:mm)	End Flow (l/min)	Duration (minutes)	Sampled Volume (l)	Respirable Fibres	Fields Searched	Total Fibre Concentration	Asbestos Fibre Concentration	Detection Limit (f/ml)	Reported Result (f/ml)
09:5510:13	15.5	14:15	15.5	242	3751	1	240	0.0000	0.0000	0.00004	<0.00004

Comments No Amphibole or Chrysotile fibres identified

Sample Number	593515-3-3	Date	05/09/23	Sample Type	Far source air test
Wind Direction	S / SSE	Wind Speed	1mph, gust 3mph	Humidity	49
Pressure	1019.3	Temperature	25.4°	Rainfall	0mm
Sample Location	Positioned adjacent to the gas pipework, 100m downwind of the soil processing area				



Site Activity Normal working conditions at time of air monitoring- diggers, earth mover machinery and pickers used on site. Dust suppression techniques used on site due to conditions as within normal working procedures.

Time on (hh:mm)	Start Flow (l/min)	Time off (hh:mm)	End Flow (l/min)	Duration (minutes)	Sampled Volume (l)	Respirable Fibres	Fields Searched	Total Fibre Concentration	Asbestos Fibre Concentration	Detection Limit (f/ml)	Reported Result (f/ml)
10:21	15.5	14:23	15.5	242	3751	0	240	0.0000	0.0000	0.00004	<0.00004

Comments No Amphibole or Chrysotile fibres identified

Sample Number	593515-4-1	Date	04/09/23	Sample Type	Near source air test
Wind Direction	S / SSE	Wind Speed	1mph, gust 3mph	Humidity	49
Pressure	1019.3	Temperature	25.4°	Rainfall	0mm
Sample Location	Positioned adjacent to the soil processing picker machine				



Site Activity Normal working conditions at time of air monitoring- diggers, earth mover machinery and pickers used on site. Dust suppression techniques used on site due to conditions as within normal working procedures.

Time on (hh:mm)	Start Flow (l/min)	Time off (hh:mm)	End Flow (l/min)	Duration (minutes)	Sampled Volume (l)	Respirable Fibres	Fields Searched	Total Fibre Concentration	Asbestos Fibre Concentration	Detection Limit (f/ml)	Reported Result (f/ml)
10:06	15.5	14:08	15.5	242	3751	1.5	240	0.0001	0.0000	0.00004	<0.00004

Comments No Amphibole or Chrysotile fibres identified

Sample Number	593515-5-1	Date	06/09/23	Sample Type	Far source air test
Wind Direction	SSW	Wind Speed	4mph, gust 12mph	Humidity	51
Pressure	1020	Temperature	23.4°	Rainfall	0mm
Sample Location	Positioned on a gantry above the tank, 50m upwind from the soil processing area				



Site Activity	Normal working conditions at time of air monitoring- diggers, earth mover machinery and pickers used on site. Dust suppression techniques used to site in line with normal working procedures, due to weather conditions.
----------------------	---

Time on (hh:mm)	Start Flow (l/min)	Time off (hh:mm)	End Flow (l/min)	Duration (minutes)	Sampled Volume (l)	Respirable Fibres	Fields Searched	Total Fibre Concentration	Asbestos Fibre Concentration	Detection Limit (f/ml)	Reported Result (f/ml)
09:23	15.5	13:24	15.5	241	3736	0	240	0.0000	0.0000	0.00004	<0.00004

Comments	No Amphibole or Chrysotile fibres identified
-----------------	--

Sample Number	593515-5-2	Date	06/09/23	Sample Type	Far source air test
Wind Direction	SSW	Wind Speed	4mph, gust 12mph	Humidity	51
Pressure	1020	Temperature	23.4°	Rainfall	0mm
Sample Location	Positioned in a SSE direction adjacent to the lagoon, 50m downwind of the soil processing area				



Site Activity Normal working conditions at time of air monitoring- diggers, earth mover machinery and pickers used on site. Dust suppression techniques used to site in line with normal working procedures, due to weather conditions.

Time on (hh:mm)	Start Flow (l/min)	Time off (hh:mm)	End Flow (l/min)	Duration (minutes)	Sampled Volume (l)	Respirable Fibres	Fields Searched	Total Fibre Concentration	Asbestos Fibre Concentration	Detection Limit (f/ml)	Reported Result (f/ml)
09:34	15.5	13:37	15.5	243	3766	0	240	0.0000	0.0000	0.00003	<0.00003

Comments No Amphibole or Chrysotile fibres identified

Sample Number	593515-5-3	Date	06/09/23	Sample Type	Far source air test
Wind Direction	SSW	Wind Speed	4mph, gust 12mph	Humidity	51
Pressure	1020	Temperature	23.4°	Rainfall	0mm
Sample Location	Positioned in a SSE direction adjacent to gas pipework, 100m downwind of the soil processing area				



Site Activity Normal working conditions at time of air monitoring- diggers, earth mover machinery and pickers used on site. Dust suppression techniques used to site in line with normal working procedures, due to weather conditions.

Time on (hh:mm)	Start Flow (l/min)	Time off (hh:mm)	End Flow (l/min)	Duration (minutes)	Sampled Volume (l)	Respirable Fibres	Fields Searched	Total Fibre Concentration	Asbestos Fibre Concentration	Detection Limit (f/ml)	Reported Result (f/ml)
09:38	15.5	13:40	15.5	242	3751	0	240	0.0000	0.0000	0.00004	<0.00004

Comments No Amphibole or Chrysotile fibres identified

Sample Number	593515-6-1	Date	06/09/23	Sample Type	Near source air test
Wind Direction	SSW	Wind Speed	4mph, gust 12mph	Humidity	51
Pressure	1020	Temperature	23.4°	Rainfall	0mm
Sample Location	Positioned adjacent to picker soil processing machinery (central point)				



Site Activity Normal working conditions at time of air monitoring- diggers, earth mover machinery and pickers used on site. Dust suppression techniques used to site in line with normal working procedures, due to weather conditions.

Time on (hh:mm)	Start Flow (l/min)	Time off (hh:mm)	End Flow (l/min)	Duration (minutes)	Sampled Volume (l)	Respirable Fibres	Fields Searched	Total Fibre Concentration	Asbestos Fibre Concentration	Detection Limit (f/ml)	Reported Result (f/ml)
09:26	15.5	13:28	15.5	242	3751	0	240	0.0000	0.0000	0.00004	<0.00004

Comments No Amphibole or Chrysotile fibres identified

Appendix B - Job Summary Report and Analytical Certificates

Asbestos Analyst's Job Summary Report

Job Ref No: **593515**, Account Ref No: **13906**, Contract Ref No: **99022**

Maw Green Soil Treatment Facility, Maw Green Road Crewe CW1 5NG

Title: Low level LOD air monitoring with SEM analysis - Maw Green Soil Treatment Facility

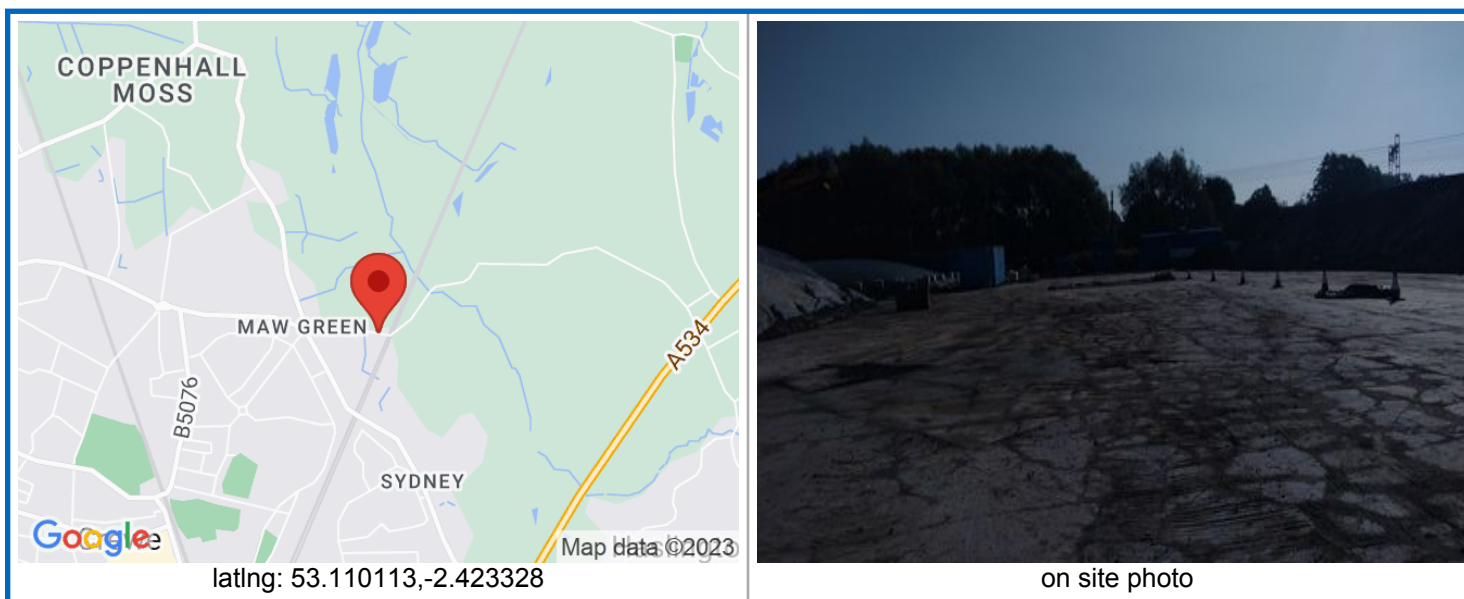

First Visit to Site: Monday, 4th September, 2023, **Last Visit to Site:** Wednesday, 6th September, 2023

Head Office
7 Halifax Court, Dunston,
Gateshead, NE11 9JT
E: enquiries@lucionservices.com
T: 0345 5040 303

Issuing Office:
LS - North West & Yorkshire
Preston Brook - Lucion Services
Ltd, 5 Abbots Park, Preston Brook,
Runcorn, WA7 3GH

Intro

This document is a summary of findings relating to asbestos analytical works at **Maw Green Soil Treatment Facility, Maw Green Road Crewe CW1 5NG** from **Monday, 4th September, 2023** to **Wednesday, 6th September, 2023**. It is intended to give an overview of testing and must be read only in conjunction with the certificates it references. The document should never be read in isolation as asbestos analysts reports often contain additional notes and advice that should be referred to.

A report is provided electronically via the NexGen web-portal. Rendering of the report will create a unique pdf version identified in the footer of the document where date and time of rendering is recorded. Document history can be reviewed via the 'View File History' when viewing the report online. Prior to commencing any works or review of the report, the most current version should be obtained via the link to the NexGen web-portal; any local pdf copies should not be relied on as containing the most current information.

















As per the client's specification, materials previously identified as containing asbestos (by other asbestos consultancies) have had this positive identification transferred to this report. Lucion Services Ltd cannot accept any liability for errors in this information.

Furthermore, this document contains a summary of analyst notes and comments made in relation to works at this site.

Please note this document may contain findings from more than one analyst on more than one date.

Key to Air-Test Icons

To aid ease of reading the following icons have been used in this document to reference commonly undertaken activities.

-  Clearance Stage 1
-  Clearance Stage 2
-  Clearance Stage 3
-  Clearance Stage 4
-  Statement of Cleanliness Inspection
-  DCU Stage 2
-  DCU Stage 3
-  Far Source Air Test
-  Near Source Air Test
-  Reassurance
-  Background
-  Leak Testing
-  Personal
-  Smoke Test Witness
-  Field Blank
-  LARC Enclosure Handover
-  Report Acknowledgement

A **WARNING** is used by the analyst to draw the readers attention to a particular area of the report.





Overview of Works

To view a complete air-certificate, follow the relevant link

 **Certificate: SEM sampling up to 150m for low LoD.**

**Building: Maw Green Soil Treatment
Facility, Maw Green Road Crewe CW1 Level: 0
5NG**





View the Full Certificate Here: https://web.lucion.co.uk/print/air_cert/98739?s=2e38221aa4b4521b7993889fe6c54b6e

Type	Test-ID	Start Time	End Time	Date	Operative	# Samples
 Far Source Air Test	593515-1			04-09-2023	 Adam Rollinson	3
 Near Source Air Test	593515-2			04-09-2023	 Adam Rollinson	1

 **Certificate: SEM sampling up to 150m for low LoD.**

**Building: Maw Green Soil Treatment
Facility, Maw Green Road Crewe CW1 Level: 0
5NG**





View the Full Certificate Here: https://web.lucion.co.uk/print/air_cert/98755?s=dbc17554f9c1bf2b7b7a165cf8581b48

Type	Test-ID	Start Time	End Time	Date	Operative	# Samples
 Far Source Air Test	593515-3			05-09-2023	 Adam Rollinson	3
 Near Source Air Test	593515-4			05-09-2023	 Adam Rollinson	1



 **Certificate: SEM sampling up to 150m for low LoD.**



**Building: Maw Green Soil Treatment
FacilityMaw Green Soil Treatment
Facility, Maw Green Road Crewe CW1 Level: 0
5NG**

View the Full Certificate Here: https://web.lucion.co.uk/print/air_cert/98771?s=62bc4552ebea364300bafacd913624da

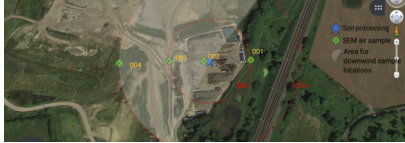
Type	Test-ID	Start Time	End Time	Date	Operative	# Samples
 Far Source Air Test	593515-5			06-09-2023	 Adam Rollinson	3
 Near Source Air Test	593515-6			06-09-2023	 Adam Rollinson	1

Job Notes

Operative	Note	Date
 <p>Adam Rollinson Senior Surveyor</p>	<p>AR-Site diary 9am arrived at site, signed in weighbridge gate house directed to propectus site. 9.05am Introduction with Andy Stockton (site supervisor), Becky (Hydrock) already present on site, agreed to await Simon (Hydrock) arrival to sit induction. 9.15am Simon arrived, Induction Started, including site discussion of days proposed events. 10.15am Visited weather station where Glen gave Becky and I weather relative information, wind direction SSE. Wind speed 3 mph Wind gust ^ 6 mph humidity 81 rainfall -none from night prior. pressure-1022.5 temperature -21.1°(22°) Dew point temp 17° site conditions- dry & sunny no dust suppression techniques utilised to site while test ran. normal working conditions at time of air monitoring- diggers, earth mover machinery, pickers used on site. 10.30am proceeded to position and run SEM air samples at 15.5L at 4x positions for 4 hours duration checking flow rates every hour. -All flow meter readings satisfactory throughout monitoring. -3.15pm completion of SEM low LOD airtests. -3.30pm Inform Simon and Andy that monitoring complete for the day, signed out at propectus site office and weighbridge site office -Left site.</p> 	Monday, 4th September, 2023
 <p>Adam Rollinson Senior Surveyor</p>	<p>AR-Site diary 8.30am arrived on site, Becky (Hydrock) arrived on site, visited Glen at the weather station. 8.40am conditions readings- wind direction -S. Wind speed- 1 mph Wind gust- ^ 3mph humidity-95 rainfall -none from night prior. pressure-1018 temperature -17.4°(18°) Dew point temp 16° site conditions- dry & sunny. normal working conditions at time of air monitoring- diggers, earth mover machinery, pickers used on site. 9am signed in at propectus site office. 9.30am proceeded to position pumps in a southern to Northern position due to wind direction. Including checking flow rates every hour. 11am Dust suppression techniques used on site due to conditions as within normal working procedures propectus dust management. 12pm Escorted Becky(Hydrock) to pumps positioning to gain environmental dust measurement relating to air monitoring positions. 12.30pm- wind direction -S/SSE. Wind speed- 1 mph Wind gust- ^ 3mph humidity- 49 pressure-1019.3 temperature -25.4°(26°) Dew point temp 26° 2.30pm All flow meter readings consistent with initial readings every hour, signed out of propectus site office. 2.35pm signed out at weighbridge site office. 2.40pm Left site.</p>	Tuesday, 5th September, 2023

Operative	Note	Date
 <p>Adam Rollinson Senior Surveyor</p>	<p>AR-Site diary 8.30am-Arrival on site, Becky (Hydrock) present at site upon arrival, signed in Weighbridge gate house. 8.40am Site conditions - wind direction -SSE. Wind speed- 3 mph Wind gust- ^ mph humidity-90 rainfall -none from night prior. pressure-1020 temperature -17.1°(18°) Dew point temp 17° site conditions- dry & sunny. normal working conditions at time of air monitoring- diggers, earth mover machinery, pickers used on site. -9am signed in at propectus site office, evidence of dust suppression to floor of site, minor water as drying. 9.15am- positioned air monitoring in line with SSE wind direction, 4 X air pumps placed running at 15.5L for 240 minutes flow rates measured hourly for duration. 11.15am dust suppression techniques used to site in line with normal working procedures, due to weather conditions. 12.30pm- wind direction -SSW. Wind speed- 4 mph Wind gust- ^12mph humidity- 51 pressure-1020 temperature -23.4°(23°) Dew point temp 18.3° site conditions- dry & sunny. normal working conditions at time of air monitoring- diggers, earth mover machinery, pickers used on site. - less evident regarding dust suppression to the floor of site, due to water previously spread is nearly completely dry - 2pm all flow meter rate readings satisfactory and consistent at 15.5L checked hourly over duration of 240minutes. 2.30pm signed out at propectus site office and weighbridge -Left site</p> 	<p>Wednesday, 6th September, 2023</p>

Attachments

The following documents accompany this report and should be regarded as an integral part of this report.

They can be downloaded from <https://web.lucion.co.uk/reports/593515/attachments>.

- [Method Statement \[https://web.lucion.co.uk/print/method_statements/593515?s=de87b7356c07104f63d45133dfcb84a0 \]](https://web.lucion.co.uk/print/method_statements/593515?s=de87b7356c07104f63d45133dfcb84a0)
- [Risk Assessment \[https://web.lucion.co.uk/print/risk_assessment/593515?s=ec208260b4a80e04f7ddb14cb6077b54 \]](https://web.lucion.co.uk/print/risk_assessment/593515?s=ec208260b4a80e04f7ddb14cb6077b54)
- [ACFrOgDquS8aPIhpwi34qfYhPc6rp1Tys1-WVgrqxBQxx9IG0ShtS7sFu2Ldm2btow2Kyn6Qw3R15UNTakIAZUU76Ffx0r9d6-TRWMUIT2m0-D83iKSYiUMZvK0aZgwFkIO4xywTP Tk6aex0L.pdf](#)
- [Figure-2---Maw-Green-Site-Arrival-Procedure.pdf](#)
- [Scope-and-Requirements.docx.pdf](#)
- [SEM-Fibre-Counting-Form---593515---Certificate.pdf](#)

Asbestos Analyst's Certificate Report

Job Ref No: **593515**, Cert Ref No: **98739**, Account Ref No: **13906**, Contract Ref No: **99022**

Maw Green Soil Treatment Facility, Maw Green Road Crewe CW1 5NG

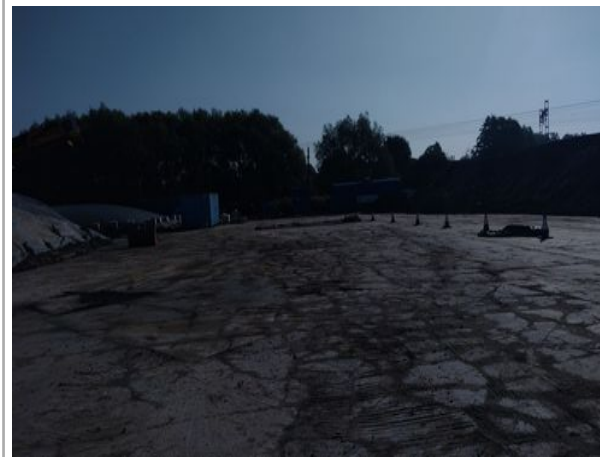

on site photo



general works area photo

Building	Level	Works-Area	Enclosure Used?	Certificate Issue Date
Maw Green Soil Treatment Facility, Maw Green Road Crewe CW1 5NG	0	SEM sampling up to 150m for low LoD.	No	Monday, 4th September, 2023

Head Office
7 Halifax Court, Dunston,
Gateshead, NE11 9JT
E: enquiries@lucionservices.com
T: 0345 5040 303

Issuing Office:
LS - North West & Yorkshire
Preston Brook - Lucion Services
Ltd, 5 Abbots Park, Preston Brook,
Runcorn, WA7 3GH

Intro

This certificate is for the attention of

James Macfarlane
Hydrock Consultants Ltd
Over Court Barns Over Lane Almondsbury Bristol BS32 4DF

Sampling & Evaluation Methods

In-house methods TOP02.08 & TOP02.09 in accordance with HSG 248 Asbestos - The Analyst's Guide to Sampling, Analysis and Clearance Procedures.

Notes: The samples referred to in this report will be retained for 6 months unless requested otherwise. Unless otherwise stated, there are no departures from the sampling and evaluation methods specified. Results detailed in this report relate only to the time, and corresponding conditions prevailing, when the sampling and examination were undertaken.

Notes to Test Accuracy

Airflow measured on site is recorded against a correction chart. Flow meters are calibrated against a UKAS certified master flow meter accurate to $\pm 0.5\%$. In accordance with HSG248, if the combined effect of ambient temperature and pressure between calibration and sampling location exceeds 5% a correction is applied to the air sample volume. The calculated fibre concentration is given for each air sample taken. Where the corresponding reported fibre concentration is preceded by "<", the lower limit of quantification (LOQ) of the method has not been reached. For a 480 litre air sample with 200 graticule areas counted, the (LOQ) of this method is 0.010 fibres per cubic centimetre of air; samples of less volume/graticules will be reported to a lower LOQ (refer count sheet, and for example, for personal sampling against the 4 hour control limit the LOQ is 0.04 fibres per cubic centimetre and against the 10 minute control limit the LOQ is 0.24 fibres per cubic centimetre). While counting randomly distributed fibres, an expected degree of variation of 1.5 standard deviations from the mean count may occur. At clearance indicator level (0.01 fibres per cubic centimetre of air) a 480-litre air sample yielding a count of 20 fibres over 200 fields would have an expected standard deviation of ± 8 fibres.

Note: the reported result is for respirable fibres and not solely asbestos fibres.

Sampling

When testing within an Enclosure and conducting a 4-Stage Clearance - the number of samples (Ns) is calculated by $A^{1/3-1}$. Where enclosure is less than 3m in height: A is denoted by area. Where enclosure is greater than 3m in height: A is denoted by volume/3. Refer air sampling and fibre counting sheet.

When testing within a decontamination unit (DCU) - where the combined floor area of shower and dirty areas is less than 10m²; 1 air test has been carried out. During this test the door between these areas has been propped open. For combined floor areas exceeding 10m² a sample in each area (i.e. shower and dirty end) will be taken.

For tests other than those associated with 4-Stage Clearance testing the analyst will apply the principles of current HSE guidance and experience combined with situational circumstances.

Where a photograph of the completed decontamination unit certificate appears in this report the analyst has completed an abridged report to be left inside the DCU; this abridged report should not be used in lieu of this comprehensive report.

Where sampling plans have been supplied; please note these are not to scale.

Where a sample filter has been deemed uncountable or biased the analyst will record this as "uncountable" in the count-sheet.

Field Blanks - Where site sampling and counting is carried out in a field laboratory a field blank is carried out by the analyst prior to the start of sampling and counting. The field blank constitutes a filter taken from a loaded but unused filter head that is mounted in the usual way and assigned a sample number which is recorded on the slide and the count sheet. Following sampling and analysis of the air tests, the results shall be assessed; where low counts ($<0.01 \text{ fcm}^{-3}$) are obtained from some of the field samples, analysis of the field blank will not be necessary. Where elevated counts ($>0.01 \text{ fcm}^{-3}$) are obtained on all field samples, then the field blank must be counted to exclude the possibility of contamination.

Disclaimers

Any opinions and interpretations expressed herein are outside the scope of UKAS accreditation. This certificate is valid only when it bears the signature of an authorised member of Lucion personnel. Please note the witnessing of smoke tests is outwith the scope of UKAS accreditation.

Representatives Signature - The signatory on report acknowledgement agrees to findings of this report being accurate and correct and Lucion Services Ltd issuing this report to the email address held on record for the job and does not require a copy of this report to be left on site. Furthermore Lucion Services Ltd cannot be held responsible for any actions undertaken following the issue of this report.

This certificate *may* be part of a series of works and should be read in conjunction with the Asbestos Analyst's Job Summary Report.

Report Contents

Test: Far Source Air Test (593515-1)	5
Sample: positioned on gantry above the tank in a NNW position (50m) (593515-1-1)	7
Sample: positioned in a SSE direction adjacent to lagoon (50m) (593515-1-2)	7
Sample: positioned adjacent to the gas pipework in a SSE position (100m) (593515-1-3)	7
Test: Near Source Air Test (593515-2)	8
Sample: positioned adjacent to soil processing picker machine(central point) (593515-2-1)	9

Test: Far Source Air Test (593515-1)

Number of samples being taken	3
Samples prepared at	SEM -Laboratory analysed
Samples counted at	SEM -Laboratory analysed
Additional Photo 1	 <p>Image Added: 2023-09-04 12:32:10</p> <p>positioned on gantry (50m)</p>
Additional Photo 2	 <p>Image Added: 2023-09-04 12:32:10</p> <p>positioned adjacent to gas pipework (100m)</p>

[table continued from previous page...](#)

Additional Photo 3



Image Added: 2023-09-04 12:32:10

positioned adjacent to the lagoon (50m)

Test: Far Source Air Test (593515-1) - Count Sheet

Lucion Report Number		Test Date			Sampled By				Counted By							
593515-1		Monday, 4th September, 2023			Adam Rollinson				Adam Rollinson							
Air Volume Correction Detail (Not applicable in the UK).																
T Cal (K)				T Site (C)				T Pcal (hPa)								
293								1013								
Microscope & Calculation Detail																
P Site (hPa)		Correction Required		Micro No.		Graticule Dia (µm)		Test Slide Result (Grid No.)			Filter Dia. Exposed (mm)					
		1		3696		100		5			22.5					
Instrument Detail																
Thermometer, Barometer		Timepiece		Flow (Hi)		Flow (Low)		HSE/NPL			Graticule Slide					
N/A		7489		273		336		5446			1667					
Sample Details																
Sample No.	Sample Location	Head No.	Pump No.	Time On (hh:mm)	Time Off (hh:mm)	Run Time (mins)	Start Flow (lmin-1)	Int Flow (lmin-1)	End Flow (lmin-1)	Calc. Volume (l)	Corr. Volume (l)	Fibres	Fields	LoQ (f/ml)	Calc. Conc. (f/ml)	Report. Conc. (f/ml)
593515-1-1	positioned on gantry above the tank in a NNW position (50m)	001	742	10:30:27	14:35:28	245	15.5	16.0	15.5	3838	3838					
593515-1-2	positioned in a SSE direction adjacent to lagoon (50m)	003	760	10:45:29	14:51:35	246	15.5		15.5	3813	3813					
593515-1-3	positioned adjacent to the gas pipework in a SSE position (100m)	004	850	11:01:38	15:01:38	240	15.5		15.5	3720	3720					

Test: Near Source Air Test (593515-2)

Number of samples being taken	1
Samples prepared at	SEM -Laboratory analysed
Samples counted at	SEM -Laboratory analysed
Additional Photo 1	 <p data-bbox="927 687 1326 708">Image Added: 2023-09-04 12:40:09</p> <p data-bbox="927 746 1630 767">positioned adjacent to picker and soil processing machinery</p>

Test: Near Source Air Test (593515-2) - Count Sheet

Lucion Report Number		Test Date				Sampled By				Counted By						
593515-2		Monday, 4th September, 2023				Adam Rollinson				Adam Rollinson						
Air Volume Correction Detail (Not applicable in the UK).																
T Cal (K)				T Site (C)				T Pcal (hPa)								
293								1013								
Microscope & Calculation Detail																
P Site (hPa)		Correction Required		Micro No.		Graticule Dia (µm)		Test Slide Result (Grid No.)			Filter Dia. Exposed (mm)					
		1		3696		100		5			22.5					
Instrument Detail																
Thermometer, Barometer		Timepiece		Flow (Hi)		Flow (Low)		HSE/NPL			Graticule Slide					
N/A		7489		273		336		5446			1667					
Sample Details																
Sample No.	Sample Location	Head No.	Pump No.	Time On (hh:mm)	Time Off (hh:mm)	Run Time (mins)	Start Flow (lmin-1)	Int Flow (lmin-1)	End Flow (lmin-1)	Calc. Volume (l)	Corr. Volume (l)	Fibres	Fields	LoQ (f/ml)	Calc. Conc. (f/ml)	Report. Conc. (f/ml)
593515-2-1	positioned adjacent to soil processing picker machine(central point)	002	871	10:40:18	14:18:10	218	15.1		15.1	3292	3292					

Asbestos Analyst's Certificate Report

Job Ref No: **593515**, Cert Ref No: **98755**, Account Ref No: **13906**, Contract Ref No: **99022**

Maw Green Soil Treatment Facility, Maw Green Road Crewe CW1 5NG

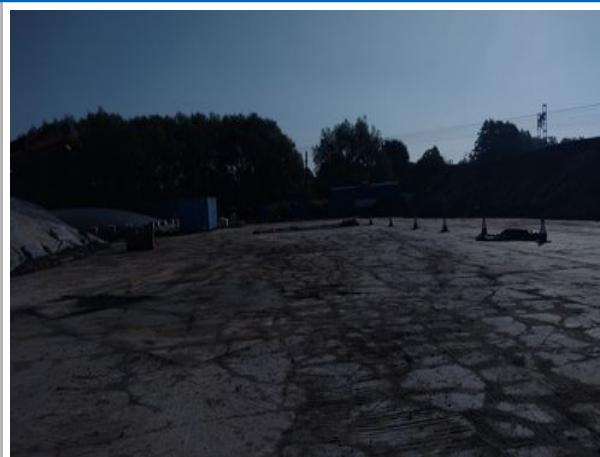

on site photo



general works area photo

Building	Level	Works-Area	Enclosure Used?	Certificate Issue Date
Maw Green Soil Treatment Facility, Maw Green Road Crewe CW1 5NG	0	SEM sampling up to 150m for low LoD.	No	Tuesday, 5th September, 2023

Head Office
7 Halifax Court, Dunston,
Gateshead, NE11 9JT
E: enquiries@lucionservices.com
T: 0345 5040 303

Issuing Office:
LS - North West & Yorkshire
Preston Brook - Lucion Services
Ltd, 5 Abbots Park, Preston Brook,
Runcorn, WA7 3GH

Intro

This certificate is for the attention of

James Macfarlane
Hydrock Consultants Ltd
Over Court Barns Over Lane Almondsbury Bristol BS32 4DF

Sampling & Evaluation Methods

In-house methods TOP02.08 & TOP02.09 in accordance with HSG 248 Asbestos - The Analyst's Guide to Sampling, Analysis and Clearance Procedures.

Notes: The samples referred to in this report will be retained for 6 months unless requested otherwise. Unless otherwise stated, there are no departures from the sampling and evaluation methods specified. Results detailed in this report relate only to the time, and corresponding conditions prevailing, when the sampling and examination were undertaken.

Notes to Test Accuracy

Airflow measured on site is recorded against a correction chart. Flow meters are calibrated against a UKAS certified master flow meter accurate to $\pm 0.5\%$. In accordance with HSG248, if the combined effect of ambient temperature and pressure between calibration and sampling location exceeds 5% a correction is applied to the air sample volume. The calculated fibre concentration is given for each air sample taken. Where the corresponding reported fibre concentration is preceded by "<", the lower limit of quantification (LOQ) of the method has not been reached. For a 480 litre air sample with 200 graticule areas counted, the (LOQ) of this method is 0.010 fibres per cubic centimetre of air; samples of less volume/graticules will be reported to a lower LOQ (refer count sheet, and for example, for personal sampling against the 4 hour control limit the LOQ is 0.04 fibres per cubic centimetre and against the 10 minute control limit the LOQ is 0.24 fibres per cubic centimetre). While counting randomly distributed fibres, an expected degree of variation of 1.5 standard deviations from the mean count may occur. At clearance indicator level (0.01 fibres per cubic centimetre of air) a 480-litre air sample yielding a count of 20 fibres over 200 fields would have an expected standard deviation of ± 8 fibres.

Note: the reported result is for respirable fibres and not solely asbestos fibres.

Sampling

When testing within an Enclosure and conducting a 4-Stage Clearance - the number of samples (Ns) is calculated by $A^{1/3-1}$. Where enclosure is less than 3m in height: A is denoted by area. Where enclosure is greater than 3m in height: A is denoted by volume/3. Refer air sampling and fibre counting sheet.

When testing within a decontamination unit (DCU) - where the combined floor area of shower and dirty areas is less than 10m²; 1 air test has been carried out. During this test the door between these areas has been propped open. For combined floor areas exceeding 10m² a sample in each area (i.e. shower and dirty end) will be taken.

For tests other than those associated with 4-Stage Clearance testing the analyst will apply the principles of current HSE guidance and experience combined with situational circumstances.

Where a photograph of the completed decontamination unit certificate appears in this report the analyst has completed an abridged report to be left inside the DCU; this abridged report should not be used in lieu of this comprehensive report.

Where sampling plans have been supplied; please note these are not to scale.

Where a sample filter has been deemed uncountable or biased the analyst will record this as "uncountable" in the count-sheet.

Field Blanks - Where site sampling and counting is carried out in a field laboratory a field blank is carried out by the analyst prior to the start of sampling and counting. The field blank constitutes a filter taken from a loaded but unused filter head that is mounted in the usual way and assigned a sample number which is recorded on the slide and the count sheet. Following sampling and analysis of the air tests, the results shall be assessed; where low counts ($<0.01 \text{ fcm}^{-3}$) are obtained from some of the field samples, analysis of the field blank will not be necessary. Where elevated counts ($>0.01 \text{ fcm}^{-3}$) are obtained on all field samples, then the field blank must be counted to exclude the possibility of contamination.

Disclaimers

Any opinions and interpretations expressed herein are outside the scope of UKAS accreditation. This certificate is valid only when it bears the signature of an authorised member of Lucion personnel. Please note the witnessing of smoke tests is outwith the scope of UKAS accreditation.

Representatives Signature - The signatory on report acknowledgement agrees to findings of this report being accurate and correct and Lucion Services Ltd issuing this report to the email address held on record for the job and does not require a copy of this report to be left on site. Furthermore Lucion Services Ltd cannot be held responsible for any actions undertaken following the issue of this report.

This certificate *may* be part of a series of works and should be read in conjunction with the Asbestos Analyst's Job Summary Report.

Report Contents

Test: Far Source Air Test (593515-3)5
 Sample: positioned adjacent to road junction in a southern position (50m) (593515-3-1)7
 Sample: positioned 50m northern position (593515-3-2)7
 Sample: positioned adjacent to gas pipework 100m in a northern position (593515-3-3)7
 Test: Near Source Air Test (593515-4)8
 Sample: positioned adjacent to soil processing picker machine (593515-4-1)9

Test: Far Source Air Test (593515-3)

Samples prepared at	SEM Laboratory analysed
Samples counted at	SEM Laboratory analysed
Additional Photo 1	 <p>Image Added: 2023-09-05 09:54:19</p> <p>positioned adjacent to junction</p>
Additional Photo 2	 <p>Image Added: 2023-09-05 10:22:40</p> <p>positioned 100m northern direction due to southern wind direction</p>

table continued from previous page...

Additional Photo 3



Image Added: 2023-09-05 10:22:40

positioned 50m northern direction due to southern wind direction

Test: Far Source Air Test (593515-3) - Count Sheet

Lucion Report Number		Test Date				Sampled By				Counted By						
593515-3		Tuesday, 5th September, 2023				Adam Rollinson				Adam Rollinson						
Air Volume Correction Detail (Not applicable in the UK).																
T Cal (K)				T Site (C)				T Pcal (hPa)								
293								1013								
Microscope & Calculation Detail																
P Site (hPa)		Correction Required		Micro No.		Graticule Dia (µm)		Test Slide Result (Grid No.)		Filter Dia. Exposed (mm)						
		1		3696		100		5		22.5						
Instrument Detail																
Thermometer, Barometer		Timepiece		Flow (Hi)		Flow (Low)		HSE/NPL		Graticule Slide						
N/A		7489		273		336		5446		1667						
Sample Details																
Sample No.	Sample Location	Head No.	Pump No.	Time On (hh:mm)	Time Off (hh:mm)	Run Time (mins)	Start Flow (lmin-1)	Int Flow (lmin-1)	End Flow (lmin-1)	Calc. Volume (l)	Corr. Volume (l)	Fibres	Fields	LoQ (f/ml)	Calc. Conc. (f/ml)	Report. Conc. (f/ml)
593515-3-1	positioned adjacent to road junction in a southern position (50m)	005	802	09:55:14	13:57:29	242	15.5		15.5	3751	3751					
593515-3-2	positioned 50m northern position	007	850	10:13:55	14:15:00	242	15.5		15.5	3751	3751					
593515-3-3	positioned adjacent to gas pipework 100m in a northern position	008	871	10:21:26	14:23:35	242	15.5		15.5	3751	3751					

Test: Near Source Air Test (593515-4)

Samples prepared at	SEM Laboratory analysed
Samples counted at	SEM Laboratory analysed
Additional Photo 1	 <p data-bbox="922 635 1326 657">Image Added: 2023-09-05 10:05:05</p> <p data-bbox="922 692 1774 721">positioned adjacent with picker and soil processing machinery north side</p>

Test: Near Source Air Test (593515-4) - Count Sheet

Lucion Report Number		Test Date				Sampled By				Counted By							
593515-4		Tuesday, 5th September, 2023				Adam Rollinson				Adam Rollinson							
Air Volume Correction Detail (Not applicable in the UK).																	
T Cal (K)				T Site (C)				T Pcal (hPa)									
293								1013									
Microscope & Calculation Detail																	
P Site (hPa)		Correction Required		Micro No.			Graticule Dia (µm)			Test Slide Result (Grid No.)			Filter Dia. Exposed (mm)				
		1		3696			100			5			22.5				
Instrument Detail																	
Thermometer, Barometer		Timepiece			Flow (Hi)			Flow (Low)			HSE/NPL			Graticule Slide			
N/A		7489			273			336			5446			1667			
Sample Details																	
Sample No.	Sample Location	Head No.	Pump No.	Time On (hh:mm)	Time Off (hh:mm)	Run Time (mins)	Start Flow (lmin-1)	Int Flow (lmin-1)	End Flow (lmin-1)	Calc. Volume (l)	Corr. Volume (l)	Fibres	Fields	LoQ (f/ml)	Calc. Conc. (f/ml)	Report. Conc. (f/ml)	
593515-4-1	positioned adjacent to soil processing picker machine	006	822	10:06:58	14:08:11	242	15.5		15.5	3751	3751						

Asbestos Analyst's Certificate Report

Job Ref No: **593515**, Cert Ref No: **98771**, Account Ref No: **13906**, Contract Ref No: **99022**

Maw Green Soil Treatment Facility, Maw Green Road Crewe CW1 5NG

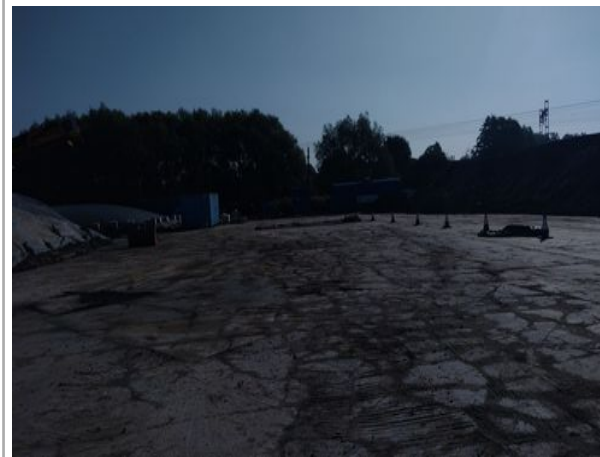

on site photo



general works area photo

Building	Level	Works-Area	Enclosure Used?	Certificate Issue Date
Maw Green Soil Treatment Facility Maw Green Soil Treatment Facility, Maw Green Road Crewe CW1 5NG	0	SEM sampling up to 150m for low LoD.	No	Wednesday, 6th September, 2023

Head Office
7 Halifax Court, Dunston,
Gateshead, NE11 9JT
E: enquiries@lucionservices.com
T: 0345 5040 303

Issuing Office:
LS - North West & Yorkshire
Preston Brook - Lucion Services
Ltd, 5 Abbots Park, Preston Brook,
Runcorn, WA7 3GH

Intro

This certificate is for the attention of

James Macfarlane
Hydrock Consultants Ltd
Over Court Barns Over Lane Almondsbury Bristol BS32 4DF

Sampling & Evaluation Methods

In-house methods TOP02.08 & TOP02.09 in accordance with HSG 248 Asbestos - The Analyst's Guide to Sampling, Analysis and Clearance Procedures.

Notes: The samples referred to in this report will be retained for 6 months unless requested otherwise. Unless otherwise stated, there are no departures from the sampling and evaluation methods specified. Results detailed in this report relate only to the time, and corresponding conditions prevailing, when the sampling and examination were undertaken.

Notes to Test Accuracy

Airflow measured on site is recorded against a correction chart. Flow meters are calibrated against a UKAS certified master flow meter accurate to $\pm 0.5\%$. In accordance with HSG248, if the combined effect of ambient temperature and pressure between calibration and sampling location exceeds 5% a correction is applied to the air sample volume. The calculated fibre concentration is given for each air sample taken. Where the corresponding reported fibre concentration is preceded by "<", the lower limit of quantification (LOQ) of the method has not been reached. For a 480 litre air sample with 200 graticule areas counted, the (LOQ) of this method is 0.010 fibres per cubic centimetre of air; samples of less volume/graticules will be reported to a lower LOQ (refer count sheet, and for example, for personal sampling against the 4 hour control limit the LOQ is 0.04 fibres per cubic centimetre and against the 10 minute control limit the LOQ is 0.24 fibres per cubic centimetre). While counting randomly distributed fibres, an expected degree of variation of 1.5 standard deviations from the mean count may occur. At clearance indicator level (0.01 fibres per cubic centimetre of air) a 480-litre air sample yielding a count of 20 fibres over 200 fields would have an expected standard deviation of ± 8 fibres.

Note: the reported result is for respirable fibres and not solely asbestos fibres.

Sampling

When testing within an Enclosure and conducting a 4-Stage Clearance - the number of samples (Ns) is calculated by $A^{1/3-1}$. Where enclosure is less than 3m in height: A is denoted by area. Where enclosure is greater than 3m in height: A is denoted by volume/3. Refer air sampling and fibre counting sheet.

When testing within a decontamination unit (DCU) - where the combined floor area of shower and dirty areas is less than 10m²; 1 air test has been carried out. During this test the door between these areas has been propped open. For combined floor areas exceeding 10m² a sample in each area (i.e. shower and dirty end) will be taken.

For tests other than those associated with 4-Stage Clearance testing the analyst will apply the principles of current HSE guidance and experience combined with situational circumstances.

Where a photograph of the completed decontamination unit certificate appears in this report the analyst has completed an abridged report to be left inside the DCU; this abridged report should not be used in lieu of this comprehensive report.

Where sampling plans have been supplied; please note these are not to scale.

Where a sample filter has been deemed uncountable or biased the analyst will record this as "uncountable" in the count-sheet.

Field Blanks - Where site sampling and counting is carried out in a field laboratory a field blank is carried out by the analyst prior to the start of sampling and counting. The field blank constitutes a filter taken from a loaded but unused filter head that is mounted in the usual way and assigned a sample number which is recorded on the slide and the count sheet. Following sampling and analysis of the air tests, the results shall be assessed; where low counts ($<0.01 \text{ fcm}^{-3}$) are obtained from some of the field samples, analysis of the field blank will not be necessary. Where elevated counts ($>0.01 \text{ fcm}^{-3}$) are obtained on all field samples, then the field blank must be counted to exclude the possibility of contamination.

Disclaimers

Any opinions and interpretations expressed herein are outside the scope of UKAS accreditation. This certificate is valid only when it bears the signature of an authorised member of Lucion personnel. Please note the witnessing of smoke tests is outwith the scope of UKAS accreditation.



Representatives Signature - The signatory on report acknowledgement agrees to findings of this report being accurate and correct and Lucion Services Ltd issuing this report to the email address held on record for the job and does not require a copy of this report to be left on site. Furthermore Lucion Services Ltd cannot be held responsible for any actions undertaken following the issue of this report.

This certificate *may* be part of a series of works and should be read in conjunction with the Asbestos Analyst's Job Summary Report.

Report Contents

Test: Far Source Air Test (593515-5)	5
Sample: positioned on gantry above tank 50m (593515-5-1)	7
Sample: positioned adjacent to lagoon 50m in a SSE position (593515-5-2)	7
Sample: positioned adjacent to gas pipework 100m in a SSE position (593515-5-3)	7
Test: Near Source Air Test (593515-6)	8
Sample: positioned adjacent to picker soil processing machinery (central point) (593515-6-1)	9

Test: Far Source Air Test (593515-5)

Samples prepared at	SEM Laboratory analysed
Samples counted at	SEM Laboratory analysed
Additional Photo 1	 <p>Image Added: 2023-09-06 09:21:23</p> <p>positioned on hantry</p>
Additional Photo 2	 <p>Image Added: 2023-09-06 09:35:07</p>
Additional Photo 3	 <p>Image Added: 2023-09-06 09:35:07</p>

[table continued from previous page...](#)

Additional Photo 4



Image Added: 2023-09-06 09:35:08

Test: Far Source Air Test (593515-5) - Count Sheet

Lucion Report Number		Test Date		Sampled By				Counted By								
593515-5		Wednesday, 6th September, 2023		Adam Rollinson				Adam Rollinson								
Air Volume Correction Detail (Not applicable in the UK).																
T Cal (K)				T Site (C)				T Pcal (hPa)								
293								1013								
Microscope & Calculation Detail																
P Site (hPa)		Correction Required		Micro No.		Graticule Dia (µm)		Test Slide Result (Grid No.)		Filter Dia. Exposed (mm)						
		1		3696		100		5		22.5						
Instrument Detail																
Thermometer, Barometer		Timepiece		Flow (Hi)		Flow (Low)		HSE/NPL		Graticule Slide						
N/A		7489		273		336		5446		1667						
Sample Details																
Sample No.	Sample Location	Head No.	Pump No.	Time On (hh:mm)	Time Off (hh:mm)	Run Time (mins)	Start Flow (lmin-1)	Int Flow (lmin-1)	End Flow (lmin-1)	Calc. Volume (l)	Corr. Volume (l)	Fibres	Fields	LoQ (f/ml)	Calc. Conc. (f/ml)	Report. Conc. (f/ml)
593515-5-1	positioned on gantry above tank 50m	009	802	09:23:13	13:24:20	241	15.5		15.5	3736	0					
593515-5-2	positioned adjacent to lagoon 50m in a SSE position	011	850	09:34:39	13:37:57	243	15.5		15.5	3766	3766					
593515-5-3	positioned adjacent to gas pipework 100m in a SSE position	012	871	09:38:59	13:40:09	242	15.5		15.5	3751	3751					

Test: Near Source Air Test (593515-6)

Samples prepared at	SEM Laboratory analysed
Samples counted at	SEM Laboratory analysed
Additional Photo 1	 <p data-bbox="925 635 1323 659">Image Added: 2023-09-06 09:48:32</p>

Test: Near Source Air Test (593515-6) - Count Sheet

Lucion Report Number		Test Date				Sampled By				Counted By						
593515-6		Wednesday, 6th September, 2023				Adam Rollinson				Adam Rollinson						
Air Volume Correction Detail (Not applicable in the UK).																
T Cal (K)				T Site (C)				T Pcal (hPa)								
293								1013								
Microscope & Calculation Detail																
P Site (hPa)		Correction Required		Micro No.		Graticule Dia (µm)		Test Slide Result (Grid No.)		Filter Dia. Exposed (mm)						
		1		3696		100		5		22.5						
Instrument Detail																
Thermometer, Barometer		Timepiece		Flow (Hi)		Flow (Low)		HSE/NPL		Graticule Slide						
N/A		7489		273		336		5446		1667						
Sample Details																
Sample No.	Sample Location	Head No.	Pump No.	Time On (hh:mm)	Time Off (hh:mm)	Run Time (mins)	Start Flow (lmin-1)	Int Flow (lmin-1)	End Flow (lmin-1)	Calc. Volume (l)	Corr. Volume (l)	Fibres	Fields	LoQ (f/ml)	Calc. Conc. (f/ml)	Report. Conc. (f/ml)
593515-6-1	positioned adjacent to picker soil processing machinery (central point)	010	822	09:26:55	13:28:07	242	15.5		15.5	3751	3751					

Appendix C - SEM Asbestos Fibre Counting Test Certificate



SEM Asbestos Fibre Counting Test Certificate

This certificate is for the attention of	David Brown Hydrock Consultants Ltd Over Court Barns
Contract Title	Low level LOD air monitoring with SEM analysis - Maw Green Soil Treatment Facility
Site Address	Maw Green Soil Treatment Facility
Test material sampled by	Adam Rollinson
Sampling date	04/09/2023-06/09/2023
Analyst(s)	Daniel Embleton
Analyst signature(s)	
Analysis date	25/9/2023
Approved signatory	Nichola Byron
Approved signature	
Approval date	27/9/2023
Report rendered on	25/10/2023

593515-1-1 positioned on gantry above the tank in a NNW position (50m)
 593515-1-2 positioned in a SSE direction adjacent to lagoon (50m)
 593515-1-3 positioned adjacent to the gas pipework in a SSE position (100m)
 593515-2-1 positioned adjacent to soil processing picker machine (central point)
 593515-3-1 positioned adjacent to road junction in a southern position (50m)
 593515-3-2 positioned 50m northern position
 593515-3-3 positioned adjacent to gas pipework 100m in a northern position
 593515-4-1 positioned adjacent to soil processing picker machine
 593515-5-1 positioned on gantry above tank 50m
 593515-5-2 positioned adjacent to lagoon 50m in a SSE position
 593515-5-3 - positioned adjacent to gas pipework 100m in a SSE position
 593515-6-1 positioned adjacent to picker soil processing machinery (central point)

Sample description

Analysis requested

Fibre counting of airborne respirable fibres using Scanning Electron Microscopy and chemical identification of the analysed fibres using Energy Dispersive X-ray Spectroscopy

Analysis method

The analysis was carried out using our in-house documented method based upon ISO14966 and VDI3492. Our method includes initial ashing of the filters (all organic fibres are also destroyed) and analysing them with SEM at a magnification of 2.07kx. 1.2 mm² of each filter is examined and respirable fibres (>5um length and <3um width with an aspect ratio of >3:1) are recorded and analysed by EDS to determine fibre type based on comparison to standard IOM reference samples.

Results and comments

0 Amphibole fibres found
 0 Chrysotile fibres found

Job number & Sample Number	Sampled air volume	Respirable fibres	No of fields searched	Total fibre concentration	Asbestos fibre concentration	Detection limit based on 95% confidence (f/ml)	Reported result (conc. f/ml)
593515-1-1	3838	1.5	240	0.0001	0.0000	0.00003	<0.00003
593515-1-2	3813	0	240	0.0000	0.0000	0.00003	<0.00003
593515-1-3	3720	1	240	0.0000	0.0000	0.00004	<0.00004
593515-2-1	3292	2.5	240	0.0001	0.0000	0.00005	<0.00005
593515-3-1	3751	0	240	0.0000	0.0000	0.00004	<0.00004
593515-3-2	3751	1	240	0.0000	0.0000	0.00004	<0.00004
593515-3-3	3751	0	240	0.0000	0.0000	0.00004	<0.00004
593515-4-1	3751	1.5	240	0.0001	0.0000	0.00004	<0.00004
593515-5-1	3736	0	240	0.0000	0.0000	0.00004	<0.00004
593515-5-2	3766	0	240	0.0000	0.0000	0.00003	<0.00003
593515-5-3	3751	0	240	0.0000	0.0000	0.00004	<0.00004
593515-6-1	3751	0	240	0.0000	0.0000	0.00004	<0.00004

Detection limit is reported as the numerical fibre concentration below which, with 95% probability, the actual concentration lies when no fibres are detected. Detection limit depends on sampled volume of air and the examined filter area. Detection limit is determined in accordance with ISO14966.

Lucion bear no responsibility for sample collection or sample description related information provided by the client.

Where Lucion Services has not undertaken the sampling; any prior sampling activity is beyond the company's responsibility. Where Lucion Services has sampled the test material, this has been done in accordance with TOP02.09 and TOP02.09.03. Any opinions and interpretations expressed herein are outside the scope of UKAS accreditation.



Appendix D - SEM Microscope Certificate

Field Service Report

Service Organization	Customer
TESCAN-UK Ltd. Unit 2 Wellbrook Court, Girton Cambridge CB3 0NA United Kingdom info@tescan-uk.com	Lucion Environmental Ltd Unit 7 Halifax court Gateshead NE11 9JT United Kingdom
Service Engineer	User
Codd, Steve steve.codd@tescan.com	Nicola Byron nichola.byron@lucionservices.com

Call Information	
System:	VEGA III LMH
Serial Number:	VG13741480
Service Order Number:	SO2200937
Coverage:	
PO Reference Number:	
Reason for Service:	
Work Performed:	<ul style="list-style-type: none"> • General system check – no issues observed or reported • Log files checked – no actionable warnings or errors • General tidying of microscope area • Specimen chamber checked for cleanliness • Timers checked for; Filament: not changed (44h), TMP: oil pads not changed (909d) • Column aligned at all kV preset ranges, astigmatism checked within spec, configuration saved to user profiles • Spray and Final Apertures checked – no contamination observed, astigmatism <10% • Gun mechanical alignment calibrated for specification required absorbed current • Rotary pump checked – in working order, colour OK, oil level good • Pumping speed checked, within spec: <3mins to Vac ready • Air/mechanical suspension checked • Image resolution/quality checked, Mag.cal. checked <+/-3% using Si 10µm grid (11999) – images recorded • and saved to (C:) > Tescan > Vega > users > service > images > PM visit Oct22 for your records • Detector check (SE) – detector showing good signal • Stage re-calibrated and checked for automation with image collection s/w and repeatability • OINA AZtec Beam Measurement and Energy Calibration run for Oxford Instruments X-Max 50 EDS Detector • Project saved under Data (D:) > 2022 > TESCAN SERVICE SEP22 • SEM left working and demonstrated to customer

Parts			
Part#	Part type	Description	Qty

Labour-Repair

Type	Date	Service Engineer	Start Time	End Time	Total (h:m)
Work	28-Sep-2022	Codd, Steve	10:30	14:00	03:30
Total labour – Repair hours					03:30

Travel Time				
Date	Service Engineer	Start Time	End Time	Total (h:m)
28-Sep-2022	Codd, Steve	14:00	15:30	01:30
28-Sep-2022	Codd, Steve	09:00	10:30	01:30
Total Travel Time				03:00

Mileage/Air Fare/Ferry/Hotel/other			
Date	Description	Unit	Qty

Closing call info	
I agree that the work indicated above has been performed to my satisfaction.	
Customer signature	
Customer: Nicola Byron	Date: 12-Oct-2022

Appendix E - Calibration Certificates

Flowmeter 273

Page Search

Help & Info
Financial
Commercial
Operational
Management
Michael Page
Recent

2018-03-09	Alf Browne	General Note	Currently not in use as Alf is on a site with its own kit
2017-11-09	Alf Browne	Transfer Ownership	
2017-09-13	Alf Browne	Asset Calibration	

Asset Calibration History...

Master Asset ID	Calibration Date	Calibrated By	Category	Result	Figures
	2018-03-19	Alf Browne	High Flow Meter	Passed	6.0, 8.1, 11.1, 14.2, 15.2, 16.2, 16.2, 15.1, 14.1, 11.1, 8.1, 6.0
2988	2018-07-13	Alf Browne	High Flow Meter	Passed	6.0, 8.0, 11.1, 14.1, 15.1, 16.2, 16.2, 15.1, 14.0, 11.0, 8.0, 5.9
2988	2019-01-23	Alf Browne	High Flow Meter	Passed	6.0, 8.2, 11.2, 14.2, 15.3, 16.3, 16.3, 15.2, 14.2, 11.2, 8.1, 6.1
2988	2019-04-25	Alf Browne	High Flow Meter	Passed	6.0, 8.1, 11.2, 14.3, 15.3, 16.3, 16.3, 15.2, 14.2, 11.1, 8.1, 6.0
2988	2019-12-03	Sean Sullivan	High Flow Meter	Passed	6.0, 8.1, 10.8, 13.9, 15.1, 16.2, 15.9, 15.0, 14.2, 10.8, 8.1, 6.0
2988	2020-05-19	Sean Sullivan	High Flow Meter	Passed	6.1, 8.2, 11.2, 14.1, 15.5, 16.0, 16.3, 15.4, 14.2, 11.1, 8.1, 6.0
2988	2020-10-06	Pete Henshall	High Flow Meter	Passed	6.0, 8.0, 11.0, 14.0, 15.0, 16.0, 16.0, 15.0, 14.0, 11.0, 8.0, 6.0
2988	2021-01-18	Pete Henshall	High Flow Meter	Passed	6.0, 8.0, 11.0, 14.0, 15.0, 16.0, 16.0, 15.0, 14.0, 11.0, 8.0, 6.0
2988	2021-04-16	Jay Kooner	High Flow Meter	Passed	6.1, 7.9, 11.2, 14.1, 15.0, 16.1, 16.0, 15.1, 13.9, 11.0, 7.8, 6.0
2754	2022-03-01	Andrew Thacker	High Flow Meter	Passed	6.0, 8.0, 11.0, 14.0, 15.0, 16.0, 16.0, 15.0, 14.0, 11.0, 8.0, 6.0
2739	2022-12-12	Andrew Thacker	High Flow Meter	Passed	6.0, 8.0, 12.0, 14.0, 15.0, 16.0, 16.0, 15.0, 14.0, 12.0, 8.0, 6.0
2739	2023-05-17	Adam Rollinson	High Flow Meter	Passed	6.0, 8.0, 12.0, 14.0, 15.0, 16.0, 16.0, 15.0, 14.0, 12.0, 8.0, 6.0
5866	2023-08-05	Adam Rollinson	High Flow Meter	Passed	6.0, 8.0, 12.0, 14.0, 15.0, 16.0, 16.0, 15.0, 14.0, 12.0, 8.0, 6.0

User Actions: Raised against this asset

Notes	Category	Raised By	Raised On	Assigned To	Action By	Completed

Page Search

Help & Info
Financial
Commercial
Operational
Management
Michael Page
Recent

Found 1 rows of data

ID	Checked Out	Unique Ref.	Assigned User	Category	Description	Valid For	Date Expires	
273	Yes	273	Adam Rollinson	High Flow Meter	300mm Flowmeter, 2.0 - 25 l/min, scale graduations every 0.5 L/min JS Holdings formally FM101	3 months	2023-11-05	

Calibration Expires: 2023-11-05

Calibration: Passed

+ Add New Asset Log
↗ Add User Action
↻ Edit Asset
✕ Close

Asset Logs...

Date	Possession of	Category	Reading	Comments	File	Photo
2023-08-05	Adam Rollinson	Asset Calibration		Asset log added after asset calibration form was completed. Asset calibration result: Passed.		
2023-05-24	Adam Rollinson	General Note		Calibration via master at luttelworth office for 3 months	jpg IMG_20230517_150444978.jpg	
2023-05-17	Adam Rollinson	Asset Calibration		Asset log added after asset calibration form was completed. Asset calibration result: Passed.		
2023-05-17	Adam Rollinson	General Note		Calibration taken place satisfactory results but unable to register via nexgen		
2023-05-04	Adam Rollinson	Transfer Ownership				
2022-12-12	Andrew Thacker	Asset Calibration		Asset log added after asset calibration form was completed. Asset calibration result: Passed.		
2022-08-15	Andrew Thacker	Quarantine				
2022-03-01	Andrew Thacker	Asset Calibration		Asset log added after asset calibration form was completed. Asset calibration result: Passed.		
2022-03-01	Andrew Thacker	Asset Calibration				
2021-12-07	Andrew Thacker	Quarantine				
2021-10-26	Andrew Thacker	Transfer Ownership		Transferred to Lutterworth office		
2021-07-21	Pete Henshall	Quarantine		awaiting calibration and re-issue		
2021-04-16	Jay Kooner	Asset Calibration		Asset log added after asset calibration form was completed. Asset calibration result: Passed.		
2021-01-18	Jay Kooner	Transfer Ownership				
2021-01-18	Pete Henshall	Asset Calibration		Asset log added after asset calibration form was completed. Asset calibration result: Passed.		
2021-01-18	Pete Henshall	Quarantine		returned to office - awaiting calibration and re-issue		
2020-10-06	PJ Butler	Transfer Ownership				
2020-10-06	Pete Henshall	Asset Calibration		Asset log added after asset calibration form was completed. Asset calibration result: Passed.		

Pump 742

Asset Calibration History...					
Master Asset ID	Calibration Date	Calibrated By	Category	Result	Figures
	2018-10-15	Adam Yates	Flow Pump	Passed	flow_reading: 16L, start_flow: 15.1, mid_flow: 15.1, end_flow: 15.1, total_flow_time: 02:00
2884	2021-06-28	Mike Castro	Flow Pump	Passed	flow_reading: 8.08, start_flow: 8.0, mid_flow: 8.0, end_flow: 8.0, total_flow_time: 02:03
4132	2022-06-20	Paul Roberts	Flow Pump	Passed	flow_reading: 8.5, start_flow: 8.5, mid_flow: 8.6, end_flow: 8.5, total_flow_time: 09:10
4132	2022-06-20	Paul Roberts	Flow Pump	Passed	flow_reading: 8.5, start_flow: 8.5, mid_flow: 8.6, end_flow: 8.5, total_flow_time: 02:01
2884	2023-07-01	Paul Roberts	Flow Pump	Passed	flow_reading: 8, start_flow: 8, mid_flow: 8, end_flow: 8, total_flow_time: 03:00

ID	Checked Out	Unique Ref.	Assigned User	Category	Description	Valid For	Date Expires
----	-------------	-------------	---------------	----------	-------------	-----------	--------------

▼ scroll down to load newer assets ▼

Microsoft Word 10.0.16.17. © 2023 Union Group Ltd. It is not the statement of the supplier that supplies, nor the most intelligent, but the one most receptive to change. ~ Charles Darwin



Found 1 rows of data

ID	Checked Out	Unique Ref.	Assigned User	Category	Description	Valid For	Date Expires
742	Yes	742	Joe Bowker	High Flow Pump	JD Technical Standard static 16ltr air pump, formerly SP36	12 months	2024-07-01

Calibration Expires: 2024-07-01

- [+ Add New Asset Log](#)
- [↗ Add User Action](#)
- [✎ Edit Asset](#)
- [✖ Close](#)

Calibration: Passed

Asset Logs...						
Date	Possession of	Category	Reading	Comments	File	Photo
2023-09-21	Joe Bowker	Transfer Ownership				
2023-07-01	Paul Roberts	Asset Calibration		Asset log added after asset calibration form was completed. Asset calibration result: Passed.		
2023-06-28	Paul Roberts	Transfer Ownership				
2023-06-26	Russell O'Regan	Transfer Ownership				
2023-06-26	Russell O'Regan	Transfer Ownership				
2023-06-13	Adam Hudson	Service		Item has been repaired and serviced	 pdf Airbox-Service-Report--742.pdf	
2023-02-01	Adam Hudson	Quarantine		Wont hold charge		
2022-06-20	Paul Roberts	Asset Calibration		Asset log added after asset calibration form was completed. Asset calibration result: Passed.		
2022-06-20	Paul Roberts	Asset Calibration		Asset log added after asset calibration form was completed. Asset calibration result: Passed.		
2022-01-05	Paul Roberts	Transfer Ownership				
2021-12-13	Conner Bradshaw	Transfer Ownership				
2021-08-27	Adam Hudson	Transfer Ownership				
2021-07-02	Paul Roberts	Transfer Ownership				
2021-06-28	Mike Castro	Asset Calibration		Asset log added after asset calibration form was completed. Asset calibration result: Passed.		
2020-10-27	Mike Castro	Transfer Ownership				
2020-10-27	Adam Hudson	Service		Battery replaced during service.	 jpg 20201027_104353.jpg	

Pump 850

NexGen

[Help & Info](#)
[Financial](#)
[Commercial](#)
[Operational](#)
[Management](#)
[Michael Page](#)
[Recent](#)

						20180815_165348.pdf	
2018-05-08	Nathan Graham	Transfer Ownership			Repair due		
2018-04-27	Todd Pankhurst	Quarantine			Returned to store for repair		
2018-04-27	Daniel Hartwell	Transfer Ownership					
2018-04-26	Todd Pankhurst	Transfer Ownership			In store		
2018-03-08	Aaron Garnett	Asset Calibration			Asset log added after asset calibration form was completed. Asset calibration result: Passed.		
2017-11-14	Aaron Garnett	Transfer Ownership					

User Actions: Raised against this asset.

Notes	Category	Raised By	Raised On	Assigned To	Action By	Completed
No user actions required...						

Asset Calibration History...

Master Asset ID	Calibration Date	Calibrated By	Category	Result	Figures
	2018-03-08	Aaron Garnett	Flow Pump	Passed	flow_reading: , start_flow: 8.0, mid_flow: 8.0, end_flow: 8.0, total_flow_time: 02:00
2884	2021-08-23	Adam Hudson	Flow Pump	Passed	flow_reading: , start_flow: 15.1, mid_flow: 15.1, end_flow: 15.1, total_flow_time: 02:00

ID	Checked Out	Unique Ref.	Assigned User	Category	Description	Valid For	Date Expires
----	-------------	-------------	---------------	----------	-------------	-----------	--------------

NexGen

[Help & Info](#)
[Financial](#)
[Commercial](#)
[Operational](#)
[Management](#)
[Michael Page](#)
[Recent](#)

✖ Archived Asset
✔ Live / Active Asset
[Reset](#)
[Search](#)



<i>Found 1 rows of data</i>							
ID	Checked Out	Unique Ref.	Assigned User	Category	Description	Valid For	Date Expires
850	Yes	850	Bradley Wild	High Flow Pump	Airbox Standard static 16ltr air pump, formally SP165	12 months	2022-08-23

Calibration Expires: 2022-08-23

Calibration: Passed

[+ Add New Asset Log](#)
[* Add User Action](#)
[🔗 Edit Asset](#)
[✖ Close](#)

Asset Logs...

Date	Possession of	Category	Reading	Comments	File	Photo
2023-09-18	Bradley Wild	Transfer Ownership				
2023-06-26	Jamie Probert	Transfer Ownership				
2023-06-26	Jamie Probert	Quarantine				
2023-06-26	Jamie Probert	Quarantine				
2023-06-13	Adam Hudson	Service		Item has been serviced and repaired.	 pdf Airbox-Service-Report-Report--850.pdf	
2021-11-11	Adam Hudson	Quarantine		Damaged mast needs repairing		
2021-08-24	Paul Bamber	Transfer Ownership				
2021-08-23	Adam Hudson	Asset Calibration		Asset log added after asset calibration form was completed. Asset calibration result: Passed.		
2021-08-19	Adam Hudson	Service			 pdf Airbox-Service-Report-Report--Lucion---AB16L0334.pdf	
2020-11-16	Adam Hudson	Quarantine		Spare kit Chester		
2020-08-11	Elena Carannante	Transfer Ownership				
2019-05-20	Jim Beaumont	Transfer Ownership				
2018-08-16	Rob Lowe	Transfer Ownership		Sent to Oldham office for allocation.		

Pump 871

Page Search

Help & Info
Financial
Commercial
Operational
Management
Michael Page
Recent

2021-10-11	Adam Hudson	Asset Calibration	Asset log added after asset calibration form was completed. Asset calibration result: Passed.
2021-09-12	Adam Hudson	Service	Unit has been serviced and repaired
2021-03-08	Adam Hudson	Quarantine	Stored at St Ashaph ready for service and mast repair
2018-10-09	Sam McDougall	Transfer Ovnershhip	
2018-03-07	Joe Erahdun	Asset Calibration	Asset log added after asset calibration form was completed. Asset calibration result: Passed.
2017-10-28	Joe Erahdun	Transfer Ovnershhip	
2017-10-27	Jamie Probert	Transfer Ovnershhip	

Asset Calibration History...

Master Asset ID	Calibration Date	Calibrated By	Category	Result	Figures
	2018-03-07	Joe Erahdun	Flow Pump	Passed	flow_reading: 8.0, start_flow: 8.0, mid_flow: 8.0, end_flow: 7.9, total_flow_time: 02:00
2884	2021-10-11	Adam Hudson	Flow Pump	Passed	flow_reading: 15, start_flow: 15, mid_flow: 15.1, end_flow: 15, total_flow_time: 02:00
2754	2022-11-22	Luke Walker	Flow Pump	Passed	flow_reading: 15, start_flow: 15, mid_flow: 15, end_flow: 15, total_flow_time: 08:01

User Actions: Raised against this asset.

Notes	Category	Raised By	Raised On	Assigned To	Action By	Completed
No user actions required...						

ID	Checked Out	Unique Ref.	Assigned User	Category	Description	Valid For	Date Expires
----	-------------	-------------	---------------	----------	-------------	-----------	--------------

▼ scroll down to load newer assets ▼

Page Search

Help & Info
Financial
Commercial
Operational
Management
Michael Page
Recent

ID	Checked Out	Unique Ref.	Assigned User	Category	Description	Valid For	Date Expires
871	Yes	871	Bradley Wild	High Flow Pump	Airbox Standard static 16ltr air pump, formerly SP189	12 months	2023-11-22

Calibration Expires: 2023-11-22
Calibration: Passed

+ Add New Asset Log
↗ Add User Action
✎ Edit Asset
✕ Close

Asset Logs...

Date	Possession of	Category	Reading	Comments	File	Photo
2023-09-18	Bradley Wild	Transfer Ownership				
2022-11-22	Luke Walker	Asset Calibration		Asset log added after asset calibration form was completed. Asset calibration result: Passed.		
2022-10-31	Luke Walker	Transfer Ownership				
2022-09-28	Adam Hudson	Quarantine				
2021-11-09	Adam Hudson	Transfer Ownership				
2021-10-17	Matt Foster	Transfer Ownership				
2021-10-11	Adam Hudson	Asset Calibration		Asset log added after asset calibration form was completed. Asset calibration result: Passed.		
2021-09-12	Adam Hudson	Service		Unit has been serviced and repaired	<div style="display: flex; align-items: center; gap: 5px;"> <div style="font-size: 12px;">pdf</div> <div style="font-size: 10px; color: #00796b;"> Airbox-Service- Repair-Report--- Lucion--- AB16L0478.pdf </div> </div> <div style="font-size: 8px; color: #00796b; margin-top: 2px;"> Click to view/download the file </div>	
2021-03-08	Adam Hudson	Quarantine		Stored at St Ashaph ready for service and mast repair		
2018-10-09	Sam McDougall	Transfer Ownership				
2018-03-07	Joe Erahdun	Asset Calibration		Asset log added after asset calibration form was completed. Asset calibration result: Passed.		
2017-10-28	Joe Erahdun	Transfer Ownership				
2017-10-27	Jamie Probert	Transfer Ownership				

Asset Calibration History...

-Service-Report-Report---Lucion---AB16L0478.pdf

Appendix F - Lucion Technical Operating Procedures



LucionServices

Protecting people and planet

TOP02.02.08 Procedure for Asbestos Air Sampling

Author
C. Parr

Approver
R. Boulton

Revision date
02 May 2023



Table of Contents

[Table of Contents](#)

[1.0 Purpose](#)

[2.0 Scope](#)

[3.0 References](#)

[4.0 Definitions and Abbreviations](#)

[5.0 Specific Procedures](#)

[5.1 Introduction](#)

[5.2 Method and planning](#)

[5.3 Equipment](#)

[5.4 General On Site procedure](#)

[5.5 Air sampling](#)

[5.6 The Four Stage Clearance](#)

[5.8 Non Licensed Removal Works - Visual inspections/ Statement of Cleanliness \(Outside the Scope of Accreditation\)](#)

[5.9 Monitoring of Enclosure Negative Pressure](#)

[5.10 Failure of Electronic Equipment During On Site Works](#)

[6.0 Documentation/Tables](#)

[6.1 Transit and Decontamination when a DCU and the enclosure aren't connected](#)

[6.1.1 Transit between multiple enclosures – Refer back to 6.1 for specifics outside of this process](#)

[6.2 Transit and Decontamination when a DCU and the enclosure are connected](#)

[6.3 Decontamination Unit Clearance process](#)

[6.4 Non-Licensed Transit and Decontamination Process](#)

[6.5 Pump flow check - via My Profile](#)

Unless stated explicitly in relation to a particular aspect, this policy applies to all activities delivered by the Lucion Group Limited companies, inclusive of:

- **Lucion Services Limited (including Lucion Infrastructure and Lucion Marine)**

The Lucion Group companies operate an integrated management system for all policies and procedures in line with our certifications and accreditations, offering a streamlined service to our clients.

1.0 Purpose

1.1 To define the procedure for carrying out air sampling onto membrane filters to measure the concentration of airborne asbestos fibre and to include the method for the conductance of visual assessments undertaken for the purpose of clearance indicator testing.

2.0 Scope

2.1 Procedure TOP02.02.08 is applicable to all personnel undertaking air sampling for asbestos fibre as defined above using method HSG 248 (current version).



3.0 References

- 3.1 LGMS Manual, SOPs and TOPs
- 3.2 HSG 248 (current version)
- 3.3 Control of Asbestos Regulations (2012)
- 3.4 Health & Safety at Work Act 1974
- 3.5 HSG 247 (current version)

4.0 Definitions and Abbreviations

- 4.1 Four Stage Clearance - a mandatory requirement following Licensed Asbestos work

5.0 Specific Procedures

5.1 Introduction

- 5.1.1 Fully trained personnel of Lucion Services carry out air sampling. Prior to carrying out sampling unsupervised, the personnel will be trained in accordance with asbestos air monitoring module and possess all prerequisite modules. Evidence of competence and supervised work must be recorded on the training record. Analysts will subsequently be audited on site at least annually.

5.2 Method and planning

- 5.2.1 Air sampling, with reference to asbestos, is the means of determining the concentration of airborne asbestos or other fibres at a specific location at the time of sampling
- 5.2.2 The method of sampling and interpretation of findings is defined in HSG 248. Sampling should be carried out in compliance with the requirements of these documents, of which analysts must have a thorough knowledge. Any deviations, in exceptional circumstances, must be clearly documented in the air test report.
- 5.2.3 Prior to starting work all hazards shall be identified and a risk assessment carried out in accordance with SOP14.01.01
- 5.2.4 Set the microscope up in accordance with the relevant procedure.
- 5.2.5 Pre site planning. For recurring or repetitive works generic contract review may be used. More specific contract review notes will either be held in the Nexgen job or contract reference. A method statement and ASB5 must be provided prior to attendance on site and this must also be contained within NexGen. The planning should also include an estimate as to the length of time taken to conduct any visual inspections. The analyst should be made aware of all information prior to attending the site in order that they are aware of Lucion's responsibilities and duties within the overall works being monitored. Additional notes will be made in the Notes and Activities section in NexGen for that particular job.
- 5.2.6 The analyst must ensure that the equipment selected is appropriate for the work being undertaken and is in a clear and sound condition. On selection of the items of equipment to be taken on site the analyst must complete the appropriate checklist pro forma for the following equipment items:

5.3 Equipment

- 5.3.1 Sampling Pumps: In addition to checking that pumps and tubing selected are clean and functioning the analyst must ensure that each pump (numbered individually) is capable of:
 - giving a smooth airflow;
 - having flow set to within $\pm 10\%$ for flow rates $< 2 \text{ litres.min}^{-1}$ and within $\pm 5\%$ for flow rates $> 2 \text{ litres.min}^{-1}$;
 - maintaining this flow rate during the period of sampling.

In addition the analyst should ensure that the pump is in a charged state (the battery indicator should be



green for fully charged). Regular use of the pump is in itself an assessment of pump adequacy, however, pumps are assessed for flow stability and battery life by undertaking a Service of the pump which is fulfilled by one of two means:

- 1) Pumps will be serviced on a 3 year basis, or less if there is a fault, by FermionX. The service will include any minor repairs and battery replacement. This is a rolling 3 year programme, where pumps are required to be sent away for this service the following will need to be completed. Ownership of the pump will be transferred to the operations manager using Asset Management in NexGen. The pump will be sent to FermionX for service, upon return the service report will be included as a record within the Asset Log within [NexGen Assets](#).
- 2) All pumps (including newly purchased units), should be subject to a run test by the 'owner' of the pump prior to them being used for testing activities, and on a 12 monthly basis. The highest achievable flow rate should be recorded in the notes section, and for:
 - a) High flow pumps, the run test will involve running the pump at a minimum of 8L/min for two hours, checking at the start, after 1 hour intervals and at the end of 2 hours.
 - b) Low flow pumps, the run test will involve running the pump at a minimum of 1L/min ideally 2L/min for 2 hours, checking at the start, at 1 hour intervals, and at the end of 2 hours.

Details can be recorded via the owner's [My Profile](#) page and will be saved in the asset log for that item. Refer to 6.4 pump flow check.

- 5.3.2 Sampling Heads: Only use numbered heads and cowls. The exposed filter diameter is determined using TOP02.02.02 and a label affixed to the container in which they are kept. The analyst must check that heads and cowls are clean before use.
- 5.3.3 Open faced filter holders with cowls of a design detailed in HSG 248 (current revision) will be used at all times. Filter heads are of the JS Holdings plastic cowl type.
- 5.3.4 Membrane Filters: 25mm cellulose ester membrane filters with a printed grid and pore size 0.8 to 1.2um. Note: from each batch of filters purchased, one filter per 100 (1%) will be mounted using the acetone/triacetin method as defined in HSG 248 (current revision). These blanks (sampling media blanks) are counted and are deemed suitable if no more than five fibres are observed in 200 fields. Any batches not conforming to these criteria will be rejected and returned to the supplier. Each satisfactory batch is identified with a suitable unique number and the result recorded and the filters made available for use. Analysts must ensure that only filters that meet the criteria are withdrawn from stock. To eliminate error only those media conforming to the aforementioned criteria will be released for use in the consumables area.
- 5.3.5 Flowmeters. The analyst must check that this equipment is labelled indicating it to be within the current calibration period. Flowmeters are calibrated against a master flow meter [calibrated by a UKAS accredited calibration laboratory against a meter traceable to national standards]. Field flowmeter calibration will be quarterly or following repair or damage. Refer TOP 02.05.
- 5.3.6 Field timepiece/thermometer/barometer. This is a single item that is capable of taking all three measurements and will be calibrated every 12 months. Refer TOP02.02.03.
- 5.3.7 Microscope, Graticule Slide and NPL/HSE Slide: The analyst must ensure that the microscope is clean, functional and carries a current service label. (Service at least every 12 months following initial purchase). The graticule slide must bear a label showing valid calibration status.
- 5.3.8 Additional items of equipment needed are wet wipes, microscope slides, tweezers with flat spatulate ends, tally counters, tablet, printer and vaporiser.
- 5.3.9 The analyst must check all items on the visual checklist to ensure all necessary equipment and materials



have been accounted for.

5.3.10 At any time, any equipment found to be damaged or malfunctioning must be immediately labelled 'DO NOT USE' with details of malfunction etc. logged in NexGen Assets and withdrawn from use and repaired or replaced at the decision of a member of the assurance team or operations manager. The repaired or replacement item must be recalibrated/checked and labelled as appropriate prior to re-issue.

Calibration Expires: 2021-03-12
Calibration: Passed

+ Add New Asset Log + Add User Action Edit Asset Close

Date	In possession of?	Log category	Reading (odometer etc).
YYYY-MM-DD	search id	General Note	

Detailed notes (e)

Asset photo
Select an image to upload
Use a large image if available

Cancel Save

Asset Logs...						
Date	Possession of	Category	Reading	Comments	File	Photo

5.4 General On Site procedure

- 5.4.1 On arrival on site the analyst must ensure that the location allocated for fibre counting is clean with unobstructed working surfaces and free from sources of contamination. If using the rear van compartment care should be taken when accessing and egressing due to restricted headroom. Work responsibilities may differ from project to site or even test-to-test and so the following should be applied as appropriate.
- 5.4.2 Work Area: Where applicable, prior to asbestos removal the analyst should inspect the construction of the enclosure (with Guidance HSG247 & 248 used as reference) and the extraction equipment assessed (current DOP certification and the capacity in relation to the enclosure size as described in L143 (second edition) paragraph 389). Relevant comments should be recorded in the NexGen air monitoring app including the extent and type of asbestos material to be removed. If a smoke test to determine enclosure integrity is carried out, the result must be recorded in the air test app (including any remedial action required). Note: witnessing of smoke tests is outside the scope of Lucion's UKAS accreditation and should normally be carried out by the contractor and only witnessed by the analyst. A bright beam "searchlight" type torch should be used to determine if any smoke is exiting from the enclosure. The negative pressure unit should remain off during this operation. The enclosure dimensions should be approximately measured in metres and noted in the air test app together with a sketch of the enclosure (sketch to include position of NPU and any roving heads used and three stage airlock entrance). A note should also be made of the hygiene facilities available (also refer to Guidance HSG247 & 248).
- 5.4.3 Preparation for Sampling. Filter heads, rings and cowls should be cleaned with wet wipes prior to use and must be allowed to dry completely. A membrane filter should be loaded onto the head with spatulate ended tweezers ensuring that the filter is positioned centrally in the head. The PTFE ring is placed on top of the filter and seated. The head is then secured to the cowl. Filter heads, cowls and filters must be



handled carefully to prevent any contamination arising.

- 5.4.4 Field Blanks. Where site sampling and counting is carried out in a field laboratory (ie a van) a field blank should be carried out prior to the start of sampling and counting. The field blank will constitute a filter taken from a loaded but unused filter head and mounted using the usual method as prescribed in this procedure. The cap of the loaded but unused filter head should be removed for 3 seconds and replaced at the point of sampling (i.e. in the case of a clearance sample, inside the enclosure). The head must not be in contact with the analyst (e.g. in a pocket).

Frequency of checks – one filter per project or per set of samples (e.g. a set of leak tests and personals performed on a site should be accompanied by a field blank) is adequate unless conditions are unusually dusty.

Field blank filters should be mounted in the usual way and assigned a sample number which is recorded on the slide and the count sheet. Following sampling and analysis of the air tests, the results shall be assessed; where low counts ($<0.01 \text{ fcm}^{-3}$) are obtained from some of the field samples, analysis of the field blank will not be necessary. Where elevated counts ($>0.01 \text{ fcm}^{-3}$) are obtained on all field samples, then the field blank must be counted to exclude the possibility of contamination. The outcome of the count should not be subtracted from the count of any samples taken under test conditions (refer Analysts' Guide section on blanks).

When a field blank(s) has indicated a need for investigation further blanks at the main laboratory (laboratory blanks) are taken from the same batch to determine the cause of spurious results. In any case the compliance manager must be informed immediately.

- 5.4.5 Before proceeding further it is necessary to ensure the accuracy of flow measurements taken on site. The need for this check arises through differences in temperature and pressure between site and calibration conditions existing. This can in turn affect the reading given by a rotameter. Lab 30 (UKAS document) specifies that flowrate is to be measured within $\pm 5\%$. The fibre count spreadsheet requires that you input the temperature and pressure at calibration conditions and also at site conditions. A difference of greater than $\pm 5\%$ will lead to a correction automatically being made to the volume of air drawn.

5.5 Air sampling

5.5.1 To take an asbestos air sample load a filter head onto a corresponding pump. Take the pump to the point of sampling and measure the flowrate, ensuring the flowmeter is held vertically and adjust as necessary using the screw adjuster on the pump to the chosen flow rate for the sample type to be taken (please note: in the case of a clearance or work area, flow measurement will need to be done immediately adjacent the enclosure [i.e. second stage of the air lock] or work area and the pump carried to the sampling position whilst running). The pump may now be placed in position for sampling, with the filter head pointing downwards and normally 1 -2 metres above floor level by use of a suitable mast. The positioning of the pump must be as close to the area where asbestos has been removed from i.e. underneath the location of AIB ceiling tiles which have now been removed. Immediately following positioning of the running pump, the time is taken and recorded on the air sample sheet as well as the location and code for the sample being taken. In order to record the on and off times of the sampling a calibrated timepiece must be taken into the enclosure by the analyst. This instrument must be suitably decontaminated on enclosure exit. On completion of the sampling run, the end time is noted and the pump remains switched on. The pump is then carried to adjacent the enclosure / work area as noted above and the end flow rate taken at this point to avoid pump recovery errors on restarting of the pump. The read flow rate is corrected as necessary and recorded as above. The duration of the sample run should be recorded to an accuracy of $\pm 2\%$. Where samples are to be transported prior to counting, the end of the cowl(s) must be capped to prevent any cross contamination. Where pumps are used in



locations where contamination could occur, the pumps must be thoroughly wet wiped. Similarly, all used filter heads/cowls must be cleaned and dried before further use. Used wet wipes must be placed in sealable bags and disposed of as potentially contaminated waste.

5.5.2 On completion of sampling the filters are ready to be mounted and counted in accordance with procedure TOP02.02.09.

5.5.2.1 In the event of a failure of the test due to a malfunction of the equipment i.e the pump battery fails mid test, the details of the test and equipment used should still be recorded on the certificate with a note detailing the reasons for the failure of the test. If required the test should then be repeated. The action described in 5.3.10 should be followed.

5.5.3 Specific sampling regimes. Depending on the reason for testing for asbestos in air a slightly different sampling procedure may be adopted in addition to the aforementioned general considerations. HSG 248 gives the following sampling strategies: personal sampling; background and reassurance sampling; leak testing; personal sampling to assess respiratory protection and clearance indicator testing. Each of these will be dealt with in turn and their procedural considerations outlined.

5.5.3.1 Personal Sampling (test code P). When sampling is carried out to determine personal exposure to asbestos for assessing compliance with the control limit the method employed is clearly laid down in HSG 248. Personal samples are also taken in an enclosure on analysts or removal operatives wearing respiratory protection to assess the effectiveness of dust suppression techniques and suitability of the RPE, such information, eg, RPE worn, the fibre type worked on, tools used by the operative, location and the duration of the activity undertaken, this must be logged within the comments section of the air test. Specific Short Duration Activity (SSDA) is used to measure the fibre level for a specific activity with a defined set of conditions presented by the work. It is primarily used to feed into the LARCs database/library of anticipated fibre levels for similar work and to check the effectiveness of controls. It can also be used to confirm the suitability of the selected RPE, the suitability of methodologies, and, subject to meeting the WHO criteria (flow rate of 1-2 l/minute, minimum volume of 240 litres, which may be pooled from more than one sample), to calculate the exposure level for comparison with the Control Limit.

The operative should be observed by the analyst for the duration of the test for SSDA so that when the activity stops, so does the test.

The filter holder should point downwards and be fixed to the upper lapel or shoulder of the worker's clothing, as close to the mouth and nose as practicable, and preferably within 200mm. Consideration should be given as to whether the wearer is left or right handed and the cowl placed on this side of the body Due regard must be given to localised concentrations; in such cases the sampling head should be positioned on the side expected to give the higher result. If a respirator is worn, the sampling head should be positioned away from the clean air exhaust. Wherever possible the HSE approved method should be adhered to (HSG 248 Appendix 1, current revision). Flow rate or time may be adjusted if required, to give a fibre density in the range of 100 to 400 fibres mm⁻². **It is preferable to count 200 fields for each sample as this will lower the detection limit as highlighted in the table below:**

	Sample volume Minimum of 40 litres (10-minute short-term exposure limit)	Specific Short Duration Activities (SSDA)	Sample volume Minimum of 240 litres (4 hour control limit)
Sample rate	4 litres/minute	2-4l/min The sampling strategy (volume of air sampled and graticules	1 - 2 litres/minute



		<p>counted) must achieve a meaningful LOQ e.g., below 0.1 f/ml.</p> <p>This typically means higher flow rates for shorter durations.</p> <p>(at least a 30 minute test)</p>	
Purpose of test	10 minute control limit	To obtain accurate exposure levels for specific tasks undertaken which feeds into exposure record, e.g. removal of AIB, fine cleaning, bag run.	4 hour control limit Assessment of RPE
Fields counted (a minimum as stated in HSG248)	100	100	100
Detection limit (based on sample volume and fields counted)	0.24 fcm ⁻³	0.08 fcm ⁻³	0.04 fcm ⁻³
Fields counted (the ideal as this improves reporting accuracy)	200	200	200
Detection limit (based on sample volume and fields counted)	0.12 fcm ⁻³	0.04 fcm ⁻³	0.02 fcm ⁻³

Analysts and surveyors need to be certain that our work methods and RPE are suitable and provide adequate protection, therefore, personal monitoring representative of various tasks should be carried out. For example, assessment of control limits during refurbishment and demolition surveys, including sampling, and assessment of RPE adequacy during various visual inspections to include AIB, insulation and sprayed coating. Assessments, when possible, must be carried out monthly and the job number referenced in your timesheet. Therefore, in summary:

- Sample for as long as possible
- Always count 200 fields
- Always calculate detection limit
- Report results correctly, either less than the limit of detection or the calculated value if it is greater than the LOD.



5.5.3.2 Background Sampling (Pre-Work) (test code B). Analysts should carry out an air test or tests adjacent to the area enclosed (or being enclosed) prior to the start of asbestos removal. The test should aim to obtain a minimum volume of 480 litres. This test is important to establish what, if any, fibre levels are present, which may influence results taken during or after work has been completed. Sample distribution should cover likely sources of fibre.

5.5.3.3 Leak Testing (During Work) (test code L). The analyst should take samples during works to detect any possible fibre leakage from the enclosure. This should include extractor exhaust where extracted air cannot be vented externally. The sample location relative to the enclosure is selected by the analyst based on judgement related to on-going visual inspection of the enclosed area, any perceived 'weak spots', efficiency of NPU and work in hand (eg. double bagged waste coming out of enclosure). Guidance HSG248 states that, where leak samples show concentrations at or above 0.01 fml-1 work should be suspended and the source investigated. The investigation should include:

- Inspecting the enclosure for defects, checking there is sufficient airlock door flap deflection,
- Inspecting the NPUs to make sure that sufficient negative pressure and airflow is still being achieved,
- Checking with the licensed contractor to determine if there has been any change in removal methods or work practices or if operatives or waste bags have just come out of the enclosure.
- Consideration of other site factors which generate airborne material (eg dry brushing, handling machine-made mineral fibres (MMMF)).

Under normal circumstances, leak tests should have a minimum volume of 480 litres (in order to allow reporting down to 0.01 fibres per millilitre of air). When an elevated number of fibres are identified and the calculated LOD is exceeded, or in the analyst's opinion it is felt that fibres are more numerous than previous tests, but the LOD has not been exceeded, then the analyst shall advise the contractor and/or client that works should cease and the source of the fibres be investigated. Preventing the leak reoccurring (eg resealing the enclosure followed by smoke testing), cleaning of areas external to the enclosure and reassurance air testing are likely to be necessary before work can recommence.

5.5.3.4 Clearance Testing. Following the completion of removal of asbestos the premises must be assessed to determine whether they are thoroughly clean and hence fit to be returned to normal occupation. It is important that this includes the premises, any plant or equipment or parts of the premises where work with asbestos has taken place and the surrounding areas that may have been contaminated. The areas requiring assessment for site clearance certification include: 1. The enclosed area including air locks of the delineated work area where an enclosure has not been used. 2. The immediate surrounding area (for enclosures this will include the outside of walls and underneath polythene sheeting used to cover floors; for delineated areas this will include surfaces nearby either where asbestos may have been spread or where the pre-cleaning was not done properly). 3. The transit route 4. The waste route and area around the waste skip.

5.5.3.5 Near Source Static Sampling. To assess the release and spread of asbestos fibre concentrations near sources (eg inside enclosures, work without an enclosure, near simulated disturbance activities in unoccupied areas, buildings and enclosures to represent typical release scenarios for normal occupation or maintenance activities, disturbance of asbestos in soil and made ground, or mineral processing etc)

5.5.3.6 Far-source Perimeter Sampling. Conducted around the perimeter of the site where there may be other workers, public access or residential and commercial buildings. Far source air tests must collect a minimum volume of 960L as per table 5.2 within HSG248 second edition



5.5.4 All air tests should be accompanied by a site plan showing the sampling locations along with any “landmarks” to allow for easy identification of where the air tests were carried out as shown below

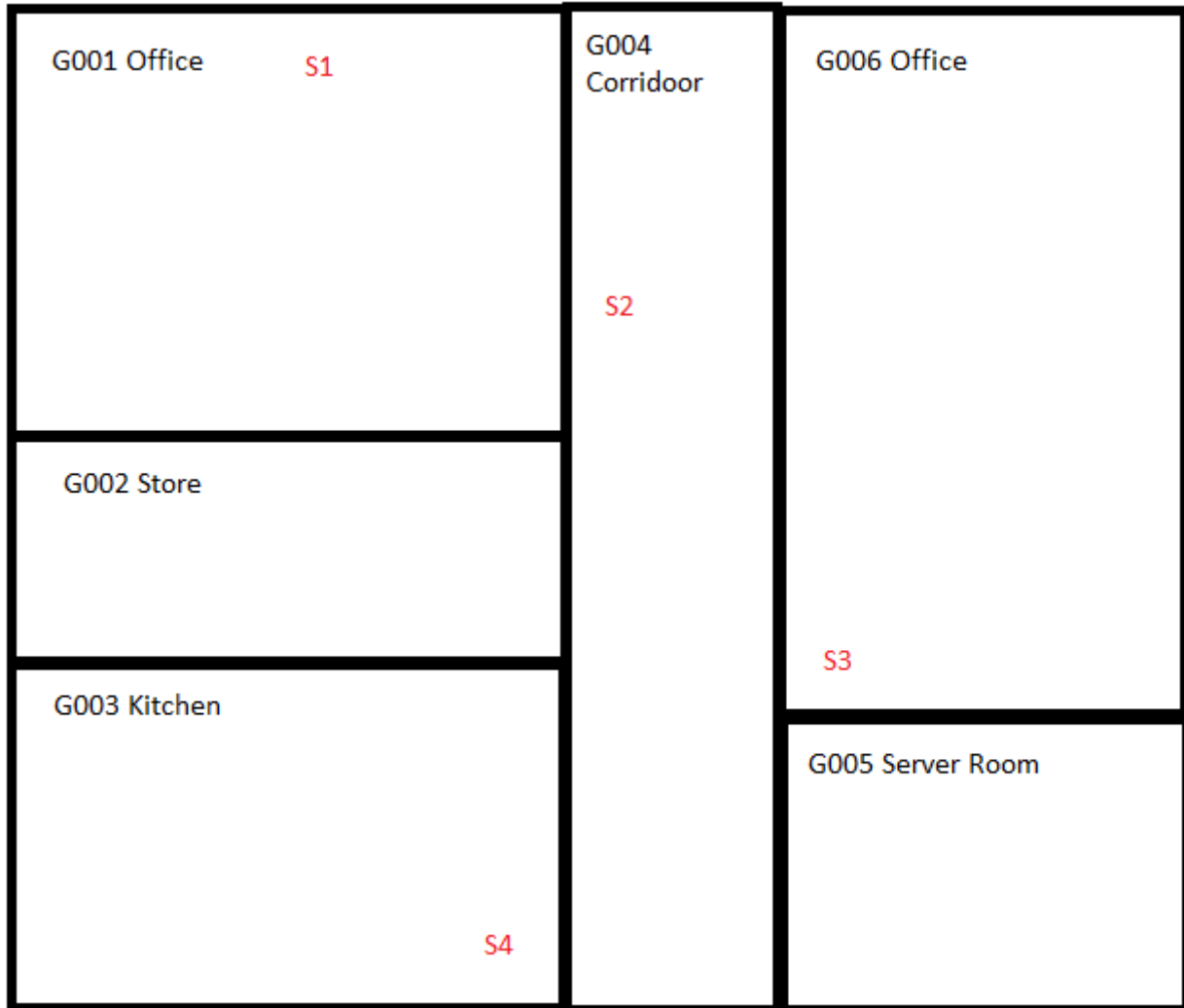

5.6 The Four Stage Clearance

5.6.1 The process of site clearance certification. The analyst must ensure that the client or contractor has thoroughly cleaned and allowed the work area to dry. This may be done through communication with the removal supervisor and /or looking through vision panels in the enclosure. The four-stage site clearance certification may now proceed. The analyst should be carrying out personal air monitoring on themselves for 5% of the enclosures entered.

5.6.2 Stage 1. Preliminary check of site condition and job completeness. At this stage the analyst should discuss aspects of the work with the site supervisor, determine the readiness of the enclosure for visual inspection based on the supervisor’s own visual assessment and review the contractor’s method statement to assure themselves that the work specified has been carried out to completeness and in the correct manner. The site supervisor should provide a completed, signed handover form for review by the analyst. A photo of this should be included in the report. HSG248 gives an example of what information should be included on the handover form. If for any reason this cannot be discerned the 4 stage clearance



must be aborted and a stage failure reported. Should the process proceed, where practical, the areas to be assessed are dry (any deviation to be recorded on air test sheet). Occasionally some surfaces or materials will need to be sealed before the disturbed air test because there may be sufficient quantities of non-asbestos dust to prevent the air test being carried out. Sealants may be used in this situation under the analysts' direction (fact to be recorded on air test sheet). Sacrificial floor layers must be removed prior to commencement of site clearance certification. The work area, enclosure, hygiene facilities and controls must be intact, operable (e.g. doors closed, fully set up and running) and clean with all ACMs included in the scope of the work and non-essential asbestos contaminated equipment removed. First, the analyst must examine the work area (normally from a viewing panel or CCTV), surrounding area, transit route, waste route and area around the waste disposal storage and all areas of the hygiene facilities must be carefully examined for the presence of asbestos containing waste and debris. Photos of the hygiene facilities clean, shower and dirty section must be taken at this time. This should also include an inspection to ensure that all tools used in the removal process (except those needed during the thorough visual inspection) have been appropriately cleaned and are safely stowed. Record these pre-inspection findings by selecting the appropriate criteria on the air test sheet and append any supporting notes. The analyst must record any remaining asbestos outside the scope of work. The analyst is to include an estimated visual time based on their assessment of the size and complexity of the enclosure presented.



Handover form	
Licensed contractor's thorough visual inspection form (to be passed to the analyst before 4-stage clearance starts) Copy to be retained by licensed contractor	
Objective: To carry out the thorough visual inspection of enclosure/work area. Areas to be clean from visible debris and dust	
Site address	
Size of enclosure? (see POW) (LxW x H (metres))	
Has the NPU been switched off and new pre-filter inserted?	Yes/No (If No, explain)
Have all ACM removal locations been checked and certified as free from asbestos?	Yes/No (If No, explain)
Have all floor surfaces/walls/items been inspected and are they confirmed as visually clean?	Yes/No (If No, explain)
Have all ledges, sills, higher level surfaces (including voids where appropriate) been inspected and are they confirmed as visually clean?	Yes/No (If No, explain)
Have ACM removal locations been checked and confirmed as visually clean?	Yes/No (If No, explain)
Have all rooms been checked and confirmed as visually clean?	Yes/No (If No, explain)
Have all cables, wiring and any items to remain in enclosure during the 4-stage clearance been checked and confirmed as visually clean?	Yes/No (If No, explain)
How long did the supervisor's visual inspection take?	
Start time	
Finish time	
Total time hours/minutes	
I certify that I have carried out a thorough visual inspection of the enclosure/ work area and can confirm that the area is visually clean and ready to be made available to the analyst for the independent 4-stage clearance	Supervisor's signature
	Date
	Time
Form to be handed to analyst before 4-stage clearance starts	Analyst's signature
	Date
	Time



5.6.3 Stage 2. Thorough visual inspection. On entire completion of the asbestos removal and actions required via stage 1, the asbestos contractor's representative should carry out a visual examination to ensure that the work area has been suitably decontaminated.

5.6.4 Once satisfied that the area is ready for visual inspection the analyst shall enter the clean end of the decontamination unit and prepare for transit to the enclosure.

5.6.5 It is mandatory that the analyst removes all items of clothing (including underwear and socks) prior to any enclosure entry (normally stage 2 visual inspection, and deployment/retrieval of sampling pumps at stage 3). Disposable Type 5/6 overalls (white for work in the enclosure, blue for transit (if available, otherwise two pairs of white coveralls), transit shoes (and then wellingtons) and an orinasal P3 filtered mask shall be available to the analyst.

Note: Swimwear may be worn by the analysts under the coveralls for privacy purposes, this can be washed in the DCU during showering and reused.

5.6.6 Transit to the enclosure from the DCU, shall be carried out in accordance with Figures 6.1 (DCU and enclosure not connected) and 6.2 (DCU and enclosure connected) and is based on current guidance and procedure in HSG248. Transit through the airlock for access to, and egress from, the enclosure is as shown below:

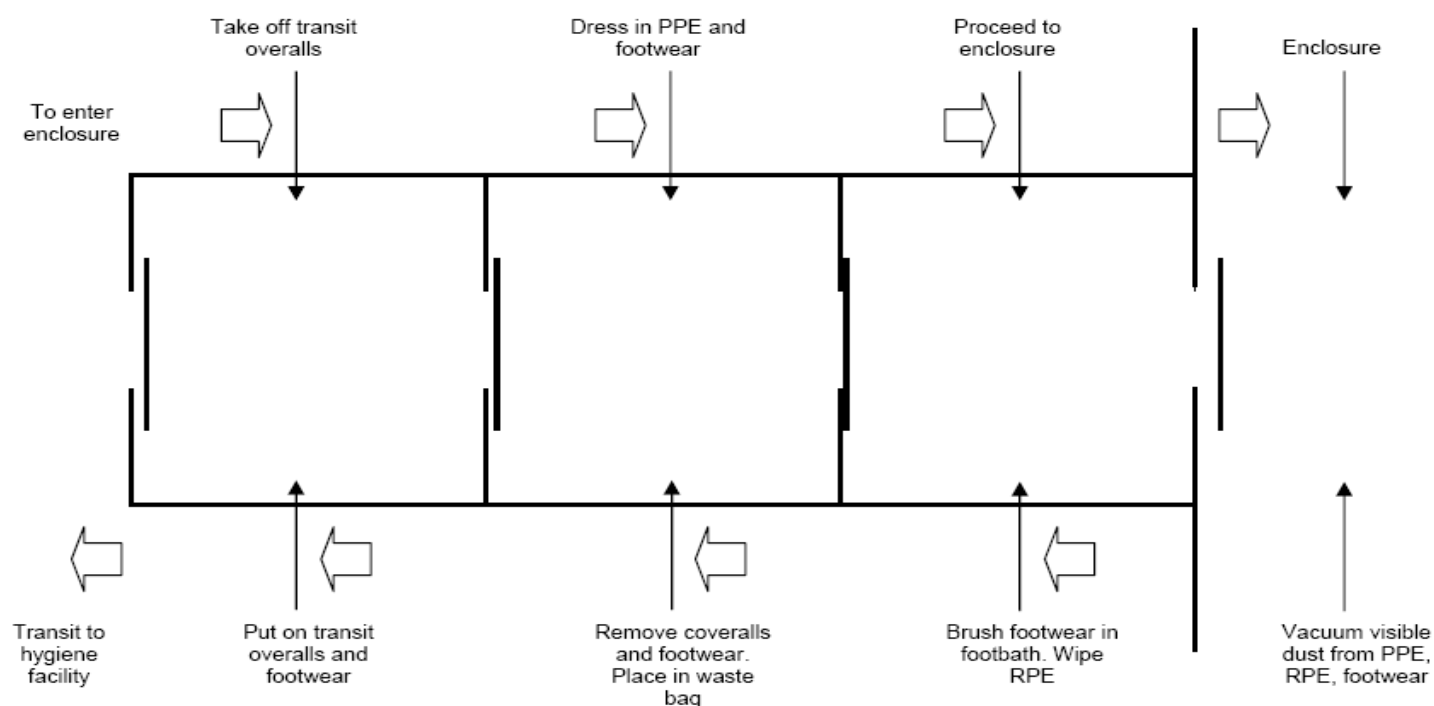

5.6.7 During transit and visual inspection of the enclosure the analyst shall ensure that their head remains covered by the hood of the overalls. RPE straps shall be underneath the hood.

5.6.8 The analyst shall carry out an inspection to ensure that the enclosure, air locks and/or work area have been thoroughly decontaminated and that the stripped surfaces have not been sealed with any wetting agents or similar (e.g. poly vinyl acetate spray) and that the negative pressure unit pre-filter has been renewed. It is essential that, as well as complete removal of the asbestos material within the enclosure, thorough vacuuming and/or wiping to all surfaces has taken place to remove any dust present. This is important since all dust, not necessarily associated with the asbestos items, may be contaminated with



fine asbestos dust from the asbestos in situ or during removal. If any items within the enclosure have been sealed with polythene to prevent contamination, it is essential that the analyst has the sealing removed prior to the visual inspection or inspects these items after dismantling of the enclosure. The method statement or plan of work should also be consulted to see if there is any doubt over the scope of the works carried out. The findings of the visual inspection must be accurately recorded on the certificate for reoccupation where the main items often checked are listed (this list is not exhaustive and it is the responsibility of the analyst to ensure all relevant items are inspected and included in the stage 2 visual inspection report along with appropriate comments). In cases where asbestos may have been left in inaccessible areas, the location and approximate extent must be recorded on the air test sheet, if extent is uncertain, e.g. beneath a floor, then justification must be provided. The analyst must ensure that the enclosed area is entirely dry. Prior to clearance air sampling where any of the above aspects are unsatisfactory the analyst must instruct the contractor to carry out remedial work followed by a visual re-inspection by the analyst. Only then may this stage of the enclosure or work area be deemed complete.

When using a torch the following guidance from table A5.3 of the Analyst Guide (Current Revision) should be followed:

“The torch beam when shone along a surface at a shallow angle is useful in identifying fine settled dust on surfaces. The angle should be as low as possible to give a long beam of light along the surface (see Figures A5.2 and A5.3). It can allow particles to be more easily observed by the shadows they cast and by the scattered light. It can also augment the lighting in the enclosure.”

5.6.9 The analyst should ensure that he or she is accompanied during the thorough visual inspection by a representative of the contractor, who can rectify any minor problems found, such as:

- holes in the enclosure not visible from the outside;
- small amounts of dust or debris found during the course of the inspection

There is an increased chance of missing contamination if the analyst carries out cleaning and the mask worn (orinasal with P3 filter to EN 140 and EN 143) is not suitable for the potentially higher levels of asbestos fibre generated during prolonged cleaning. Therefore, if the analyst decides that there is still an unacceptable level of contamination in an enclosure, or the contractor refuses to carry out any cleaning that is requested, then the visual inspection shall fail. Remember: As an analyst you are there purely to ensure the enclosure is clean and not to clean it - this is the job of the licensed asbestos removal contractor. In the instance that the analyst deems it necessary to fail the stage 2 visual inspection, the analyst must begin again at stage 1 when carrying out the reinspection of the area. **Remember: The purpose of stage 1 amongst other things is to check the enclosure integrity and the surrounding area, anything could have happened to the enclosure in the time between visual inspections.**

5.6.10 The analyst is required to record details of any minor cleaning that is required to be undertaken by the contractor, and should the cleaning take more than ten minutes in total, the visual should be failed.

5.6.11 The analyst must ensure that all non-essential equipment is removed from the enclosure. Equipment that should remain in the enclosure to help the inspection includes:

- Step Ladders / scaffolding – depending on the height of the enclosure one or other will be needed to allow safe access to inspect ledges etc above head height
- Lighting – a thorough inspection needs lighting, a torch alone is not enough. The torch should be used to supplement the background lighting, not replace it
- Vacuum cleaner and other cleaning materials – this will allow the contractor to clean any minor amounts of debris identified immediately; a vacuum cleaner must also be available



for preliminary decontamination on leaving the enclosure

- Buckets of water and sponges and brushes or wipes in the airlock to allow preliminary decontamination following the visual inspection

5.6.12 On decision to leave the enclosure the analyst shall pass through the airlock as shown in the diagram above. Overalls should be removed and placed in an asbestos waste bag in the middle section of the three-stage airlock. Wellingtons should also be bagged prior to removal from the airlocks. The analyst should dress in clean transit overalls (or remain in the 'base layer' coveralls) and transit shoes in the first stage of the airlock prior to transit to the decontamination unit. (Refer to HSG248 and flow charts below in Section 6 of this TOP).

5.6.13 Stage 3: Clearance Air Monitoring (test code C). Following the successful completion of the visual inspection air monitoring must be carried out to check that the concentration of airborne fibres remaining in areas affected by the works is as low as is reasonably practicable. The analyst must ensure that the negative pressure unit is switched off and the enclosure side of the filter is capped prior to clearance sampling. However, if, in the opinion of the analyst, switching the air extraction system off would compromise the integrity of the enclosure, and there are people near the enclosure who may be exposed to airborne asbestos fibres as a consequence, the analyst can direct the contractors to leave the system switched on during the air test. Any decision to leave the air extraction system switched on should be noted, with reasons why, on the CfR Air clearance sampling may then proceed. Note: It is mandatory to follow the transit and decontamination procedure described above (5.6.3 Stage 2) if you leave the enclosure to collect any equipment you might have in the vehicle. Where all your pumps and other equipment are with you in the stage 2 airlock, you can directly proceed to carrying out stage 3.

5.6.14 The sampling procedure is to be carried out as described in HSG 248, with a minimum air volume of 480 litres being sampled at a rate not greater than 16 lmin^{-1} , with 15 lmin^{-1} being the normal expectation.

5.6.15 The minimum number of samples to be taken is to be based on the formula given in HSG 248 (current revision). It is important to note that the formula gives a minimum number of samples. In enclosed areas, which are subdivided, an increased number of samples may be required. A help sheet ([sample no's vs enclosure size](#)) is also available. The following should also be borne in mind:

- Sampling equipment should be distributed throughout the enclosure
- At least half the samplers should be close to or underneath where the asbestos was removed
- Sampling heads should be 1-2m from the floor with filter holders pointing in a downward direction
- In tall enclosures (e.g. lift shafts etc) samplers should be placed at representative exposure heights. For enclosures with floor areas $>20\text{ m}^2$ a long-handled broom should be used to sweep the floor, for both ergonomic and practical reasons.
- There should always be at least two measurements taken except where enclosure areas are less than 10 m^3 .

When sample collection begins, enclosure surfaces must be disturbed for a minimum of 1.5 minutes per sample taken/pump run, where possible with the aid of a brush (to mimic normal post removal cleaning activities). The disturbance time and pump on and off times should be recorded. Sample locations within the enclosure should be recorded on the enclosure sketch. After disturbance, the brush should be left in the enclosure and treated as contaminated waste. At this point all primary records, i.e pump numbers, cowl numbers, pump on/off times should be recorded via the Nexgen app on a tablet, sealed within a clear plastic bag. If this method/tablet was to fail, a laminated enclosure sample location sheet should be used with a permanent marker to make an enclosure sketch, mark the sample locations and the pump/head numbers and the on and off times of the pumps. The collected information shall be transcribed into



the air monitoring app, additionally, the completed sheet should be photographed (as evidence of use) and saved within the CFR. The sheet shall be wiped clean once the information has been recorded.

5.6.16 It is at this point that the enclosure sketch will normally be drawn on the tablet or on the Lucion site sketch plan template. It is essential that this sketch is both accurate and detailed so it may be used to “piece together” the work area and surrounding facilities in the future. As a minimum the sketch must (where appropriate) identify the enclosure location, 3 stage airlock position, NPU position, hygiene facility location, waste route and waste storage facility (“van” may be marked if appropriate) and personnel transit route. Cut through style lines may be used to indicate greater distances than the scale of the drawing will allow. Approximate dimensions and distances should also be marked on the sketch in addition to sampling locations. An example follows. Transit route, waste route and enclosure location should be marked relative to “landmarks” to allow these elements to be located in future.

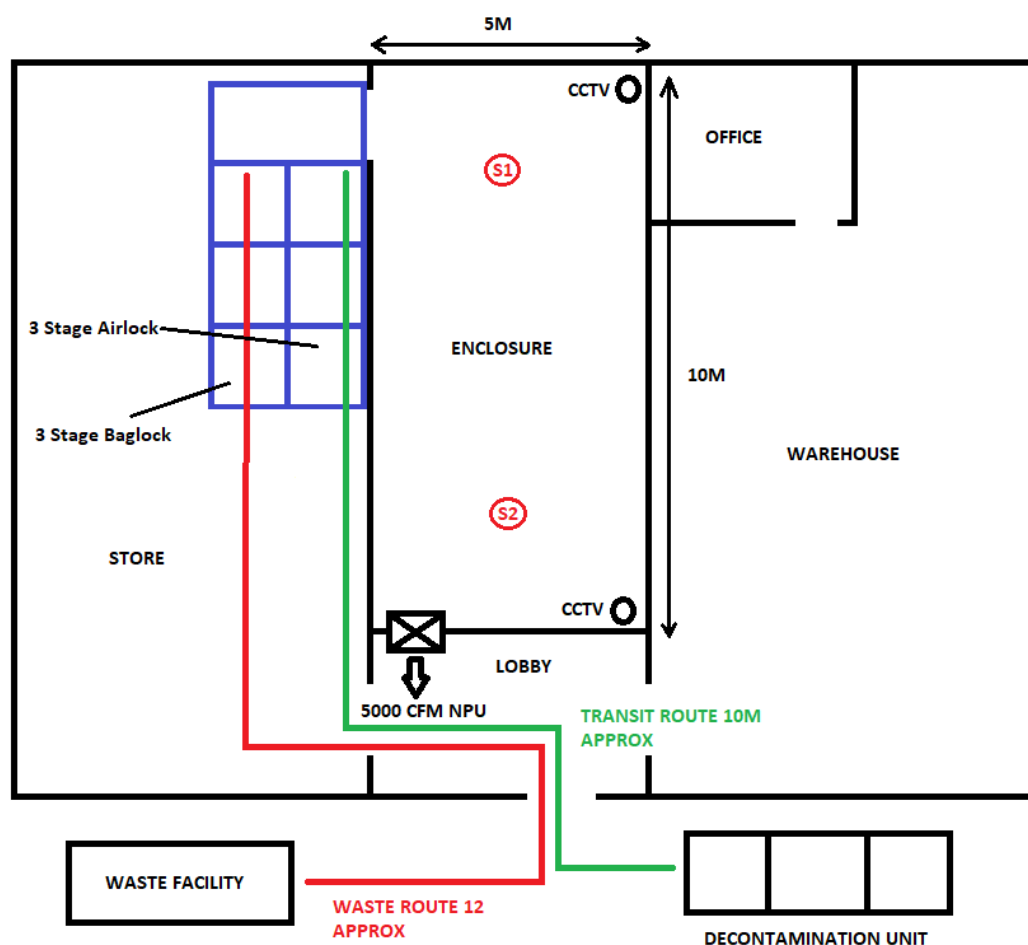

5.6.17 On completion of the sampling carried out the sampling details are recorded and the fibre count, this is carried out in accordance with TOP02.02.09. In the instance that the air sampling results exceed the clearance indicator of 0.01 fibres ml⁻¹ then the analyst should proceed to fail stage 3 and inform the supervisor of the necessary actions. The analyst is not required to restart the 4 stage clearance and can continue to retest the area following completion of the informed actions.

5.6.18 Stage 3 of the 4 stage clearance is deemed to have passed if:

- Less than 5 pumps are being used and all air tests are below the clearance indicator of 0.01 fibres ml⁻¹ or
- Greater than 5 pumps are used and; 80% of the air tests are below the clearance indicator of 0.01 fibres ml⁻¹ and the remaining 20% are no greater than 0.015 fibres ml⁻¹



Stage 4 of the clearance procedure now applies. A type H vacuum cleaner and suitable PPE & RPE should be kept available during dismantling allowing any small amounts of trapped debris to be cleared up. Once the enclosure has been entirely removed, the analyst should finally reinspect the area to ensure that no debris remains. If excessive debris or dust is released the enclosure should be re-erected, the area cleaned and the clearance procedure reinitiated. The analyst on site may make this decision, however, the regional technical lead or regional manager should be informed at the analyst's earliest convenience.

Throughout all stages of the 4 stage clearance, photographs must be taken using the NexGen mobile app as prompted and required. A sufficient number of photographs must be taken of the enclosure after the visual inspection and stage 4.

5.6.19 Clearance Certification. Following successful completion of all four stages, the certificate of reoccupation can be signed (using a finger on the tablet screen), uploaded to NexGen and issued by email (this is the standard Lucion issue format) to the client and removal contractor. If, on occasion a hardcopy is required, then a printed copy can be generated. The analyst must also ensure that the signature of the contractor's representative is obtained on the tablet (During Covid-19, if the analyst is uncomfortable with the supervisor using their handheld device, this step maybe skipped but a note must be made as to why). In the event of failure (at any stage), the analyst is to issue those pages completed up to the fail point and mark the fail section as being unsuccessful. A reason may be given in the notes box of the certificate for the failed stage. In addition, the site sketch plan should also be completed to include those elements inspected up to the point of failure e.g. the transit and waste routes should be included if a stage 1 failure is incurred.

5.6.20 Hygiene facility testing. Prior to departure from site analyst should be asked to perform a visual examination and clearance air test in the dirty end and shower section of the decontamination unit. This test is to be carried out only upon the request of the contractor or their site representative. This test should be carried out as a separate air test (the same project may be used).

5.6.21 Reassurance Sampling (test code R). This type of sampling is used to check that no significant fibre has been released when areas are detented or where asbestos has been worked or encapsulated without enclosing the area. The sampling strategy is at the discretion of the analyst in terms of number and location, but samples should be of sufficient volume that results be expressed to the lower limit of accurate measurement of 0.01 fibres per millilitre of air, i.e. 480 litres. Numbers of samples should also be sufficient to give a representative cross-section of the area of concern. Reassurance air tests should not be conducted until the location has been inspected to confirm that there is no suspect dust and debris. This should be recorded in the NexGen app with supporting photos where required.

5.6.22 Following completion of the abatement works, the analyst should utilise the "link air certificate" function within NexGen to update the current asbestos register. If an analyst, who doesn't hold a valid P402 or equivalent is required to amend the material assessment score, e.g the product has been encapsulated, then this amendment to the data must be reviewed by an authorised surveyor or report checker. (An internal note can be included in NexGen). Reporting of results. All data must be synchronised with NexGen at the end of each day. Standard issue of any air monitoring or COR report is by email to the client. A unique link is provided to the report's location in NexGen. On occasion when a hard copy may be required immediately on site, the analyst has the facility to print a copy.

5.6.23 Length of Visual Inspection. The analyst should make sure that there is sufficient time available to



complete the visual inspection. The estimated time should be recorded in stage 1. If the actual time taken recorded on stage 2 differs by more than 20% then additional comments should be recorded detailing the reasons for this difference. HSG248 has given guidance on suggested visual lengths for various remediation works.

ACM	Location	Size of area or volume	Complexity/difficulty	Estimated time required
AIB				
AIB	Ceiling tiles plus void	500–600 m ²	Very difficult	8 hours
AIB	Selective ceiling tile removal	200–300 m ²	Not very complex but time-consuming	3–4 hours
AIB single panel	Domestic cupboard, small enclosure	6–10 m ²	Not very complex. Some pipes, shelf, skirting etc	15–30 minutes but up to 1 hour
AIB soffit	External	20–40 linear metres	Not complex but high-level with mobile platform	1–4 hours
AIB	Panel(s) below window	20–30 m ²	Not complex	0.5–2 hours
AIB	Ceiling tiles plus void	25–50 m ²	Quite difficult. Services, cable trays	1–4 hours
AIB	Ceiling tiles plus void	100–150 m ²	Quite difficult. Services, cable trays	2–6 hours
AIB	Ceiling tiles plus void	200–300 m ²	Quite difficult. Services, cable trays. Time-consuming	4–8 hours
Lagging/insulation				
Pipe insulation/lagging	Boiler room	50–100 m ² (pipes) (150–300 m ³) (vessels)	Complex. Various vessels, pipes, ledges	2–4 hours to 1–2 days
Pipe insulation/lagging remnants from previous removal	Boiler room	50–100 m ² (pipes) (150–300 m ³) (vessels)	Complex. Various vessels, pipes, ledges	2–4 hours to 1–2 days
Asbestos debris (lagging/AIB)	Ceiling void	25–50 m ²	Quite difficult. Services, cable trays. Time-consuming	1–6 hours

Notes

- 1 The degree of 'sheeting out' by the licensed contractor will greatly affect the time needed to conduct a visual inspection on similar removal works.
- 2 Ceiling voids may be devoid of fixtures/fittings or full of them; this will also affect the time required.

5.7 Site Safety

5.7.1 Analysts are required to comply with individual site safety requirements (safety footwear, hi-vis, ear protectors etc where applicable) and any specific transit procedures that the Licensed Asbestos Contractor may require that you follow.



- 5.7.2 Equipment used in the enclosure (ie sampling pumps, screwdriver, mirror etc) must be wiped with wet wipes in the airlock prior to removal from the enclosure.
- 5.7.3 Remember RPE and PPE must be inspected before and after each use and a recorded inspection carried out weekly.
- 5.7.4 HSG53 states that wearing a half mask for over 1 hour can lead to the face seal being compromised. Where an analyst is required to wear a mask for longer than 1 hour, they should retreat to the airlock where a check of the seal is performed. If the seal check is satisfactory then the work can continue. Should there be an issue with the face seal, or the analyst feels it necessary to remove the RPE, then the analyst should decontaminate and take a short break before recommencing activities. If when the job is being set up there is a likelihood of the visual inspection lasting longer than 1 hour, the use of a full face powered respirator should be considered.
- 5.7.5 The analyst should decide, based on the on site risk assessment, and their assessment of the enclosure , whether a full face or half mask is most appropriate. This should include the length of inspection, physical access requirements, and comfort. The analyst should record the ID number of the mask they have worn during the Four Stage Clearance.

5.8 Non Licensed Removal Works - Visual inspections/ Statement of Cleanliness (Outside the Scope of Accreditation)

- 5.8.1 On occasion a client may require visual confirmation from the analyst that a non licensed material has been removed (in addition to reassurance air monitoring). Where this is requested the following procedure shall be used for the inspection itself and recording of information.
- 5.8.2 The basis of the recording of this visual assessment will be the “Statement of Cleanliness” function of the air monitoring app.
- 5.8.3 The analyst must hold any Four stage clearance authorisation to carry out the Visual Inspection.
- 5.8.3 The analyst shall establish the exact scope of the removal in the contractor’s method statement. The visual inspection should then confirm that all the non licensed materials have been removed as per the scope of works and that no visible fragments or residues remain. Where there are unavoidably areas of no access or ACMs from the scope of works remaining in situ then these must be recorded (see 5.8.5). Note: the contractor must provide safe access to all areas for this inspection. It is not acceptable to rely on the contractor’s word that “everything has been removed”. The analyst should have a sufficiently bright torch (and have suitable tools if necessary i.e: flat end screwdriver etc) to aid the inspection.
- 5.8.4 The analyst must draw a sketch plan of the work area. This should show the positions of any air tests and the extent and locations of the ACMs removed. It should also show the locations of any ACMs that unavoidably are remaining in situ and any unavoidable non accessed areas as well as any transit/waste routes and any decontamination facilities/skips.
- 5.8.5 Photographic evidence , with appropriate accompanying statements, will be required showing:
 - A clear photograph of the site sketch plan.
 - A photograph of the scope of removal in the contractor’s method method statement with a brief statement summarising the scope i.e: removal of cement pipe from riser in room 10, vinyl floor tiles from rooms 1, 2, 3 etc.
 - At least one photograph of the area from where the ACMs have been removed to show that they are no longer present. For larger jobs or for numerous non licensed removals several photos will be required. If all ACMs have been removed as per scope of works then the following statement should accompany this photograph: “All ACMs have been removed as per the scope of works”.
 - Photographs of any ACMs remaining in situ and any areas that were inaccessible along with a suitable description.



- Photographs of the transit/waste routes after the removal as well as waste facilities.
- Any other additional information that you think might be of relevance.
- Note: If you are on site before removal takes place it is good practice to photograph the area before removal.

5.8.6 When organising site works of this type, managers should provide all necessary information regarding the location, scope of works etc to the surveyor by populating the appropriate areas of the “job details” on NexGen.

5.8.7 Half masks with P3 filters and disposable coveralls should be worn during the visual inspection, however due to the much lower levels of risk from fibres on licensable works, normal clothing can be worn underneath. RPE, any tools used, tablets etc can be decontaminated with wet wipes. Used coveralls and used wet wipes should be disposed of as asbestos waste.

5.9 Monitoring of Enclosure Negative Pressure

5.9.1 If required under the terms of the contract. Lucion will in the first instance instruct the Licenced Removal Contractor to conduct negative pressure monitoring on their enclosures using the methods laid out in their own procedures.

5.9.2 If the contractor is unable to carry out these measurements, the analyst will measure the negative pressure at agreed locations on the enclosure using either an Electronic Differential Pressure Monitor or a Dwyer Gauge. Monitoring locations will be agreed between the Analyst and the LARC supervisor due to each enclosure being unique with differing configurations and air movement.

5.9.3 If the pressure difference between inside and outside the enclosure is greater or equal to 5 Pa on the electronic meter or 0.5mm / 0.02 inch water gauge on the scale of a Dwyer Gauge then it will be deemed satisfactory.

5.9.4 It should be noted that pressure in an enclosure may not be uniform and subject to other influences, e.g. outside wind pressure, particularly when doors and windows are open in the building. Other indicators, such as correct functioning of NPUs and deflection of airlock flaps will often provide viable evidence of airflow and that the air management within the enclosures is functioning correctly.

5.9.5 Results of satisfactory measurements will not be recorded. In the event of an unsatisfactory reading, an external comment (via Job Notes) will be added to the air monitoring certificate detailing the unsatisfactory reading value, location, actions taken to rectify the situation and confirmation that the negative pressure is now satisfactory following actions completed.

5.10 Failure of Electronic Equipment During On Site Works

5.10.1 In the event of a hardware/software failure on site, paper hard copies of the air monitoring documentation should not be used. The local office should be contacted and a replacement device requested.

If a replacement device can not be sourced in a reasonable time frame then the details of the works can be dictated to another user to be entered into a working device. An external note should be included in the job to acknowledge that results etc were dictated by the analyst on site to another person over the phone.

5.10.2 In the event of the app being unavailable the calculations required to report fibre concentrations are located in [TOP02.02.09](#)

5.11.3 If at Contract Review stage it is identified that electronic devices can not be used then a blank version of



the CfR should be printed out and all details recorded in writing. This information must be transcribed to the user's tablet once available. A photograph of the handwritten notes uploaded to the file store and any relevant external/internal notes recorded.



6.0 Documentation/Tables

Note: In addition to the procedures outlined below swimwear may be worn by the analysts under the coveralls for privacy purposes, this can be washed and cleaned in the DCU during showering and reused.



6.1 Transit and Decontamination when a DCU and the enclosure aren't connected

Transit and decontamination when a DCU and the enclosure aren't connected

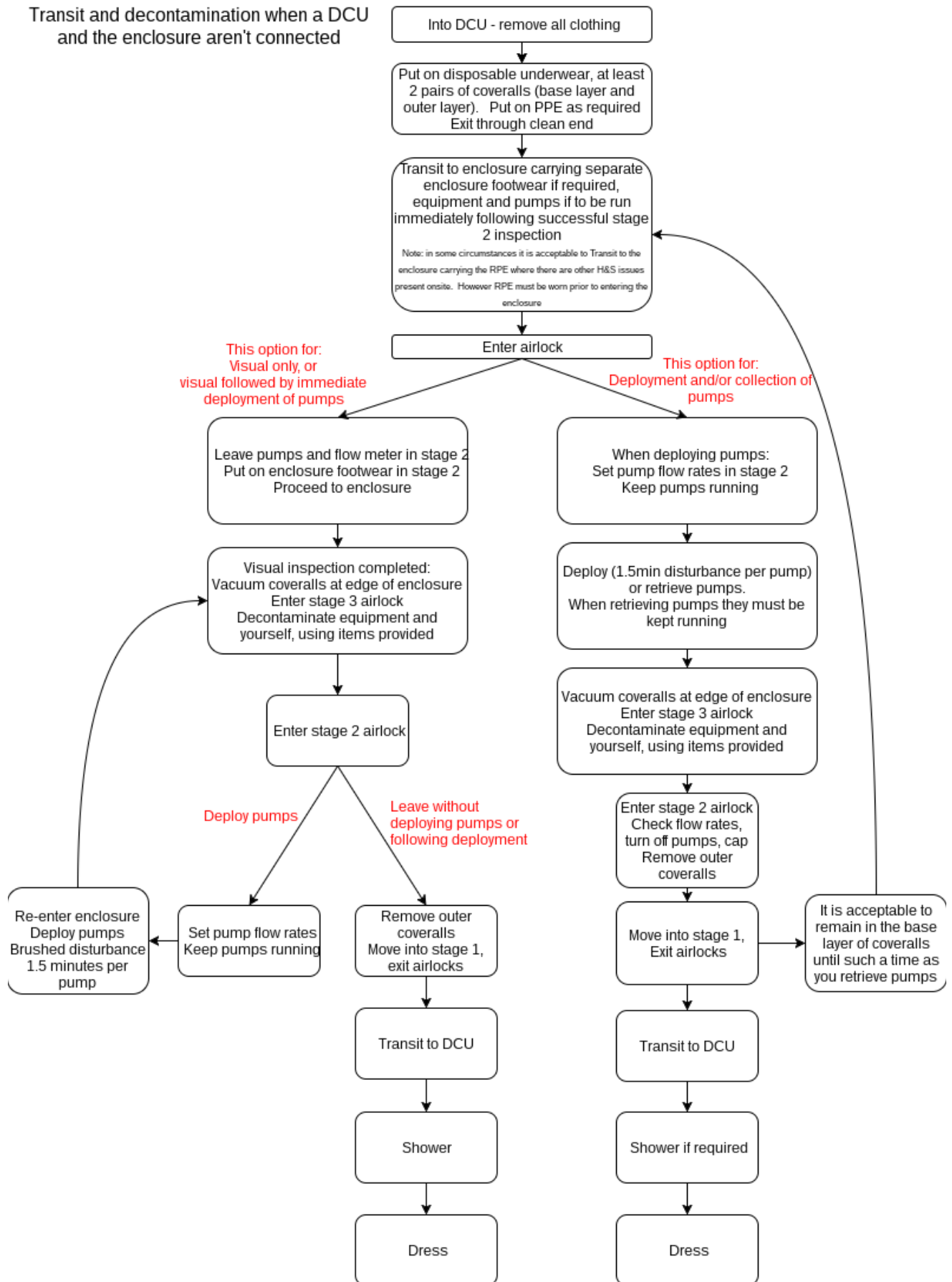



6.1.1 Transit between multiple enclosures – Refer back to 6.1 for specifics outside of this process

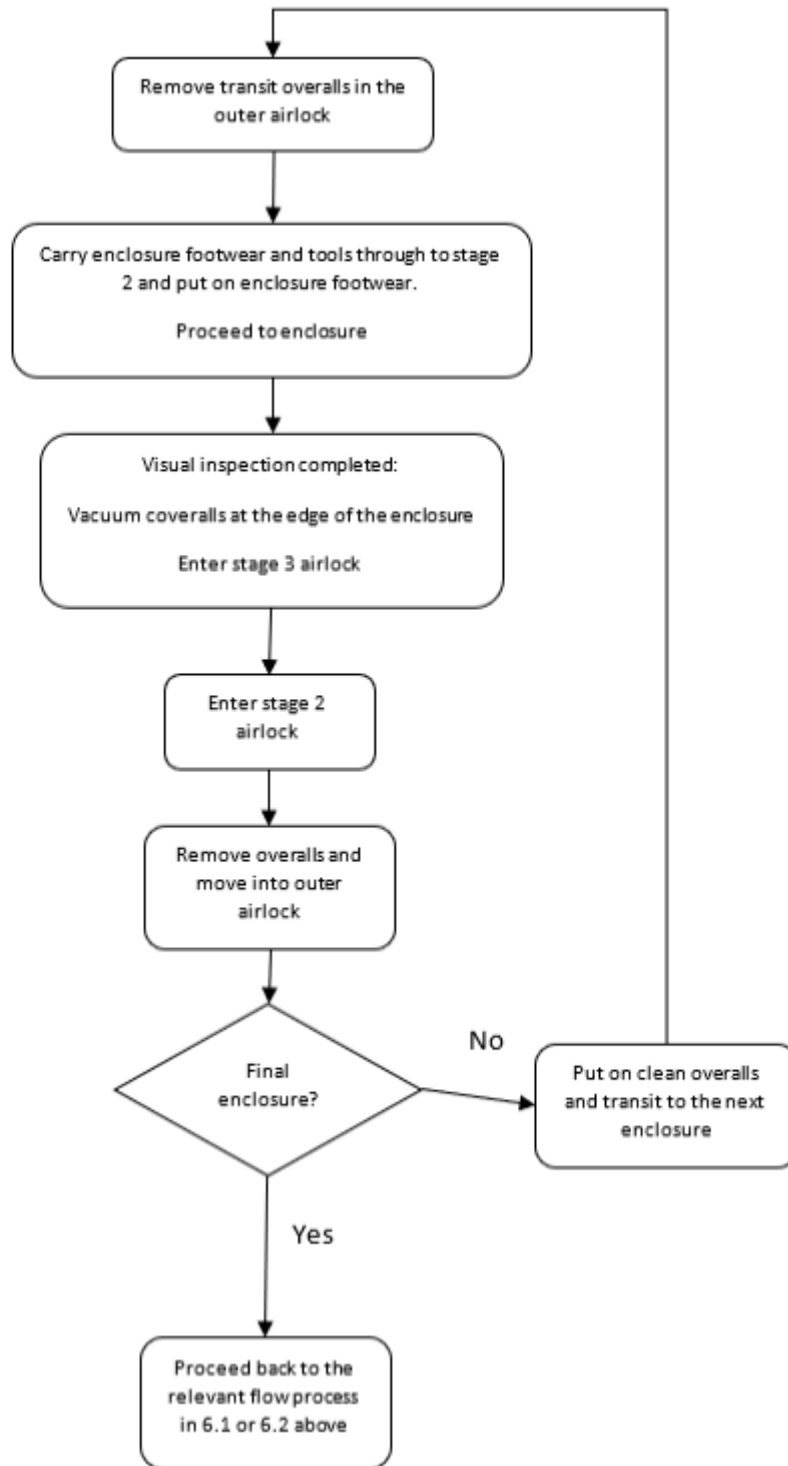



6.2 Transit and Decontamination when a DCU and the enclosure are connected

Transit and decontamination when a DCU and the enclosure are connected

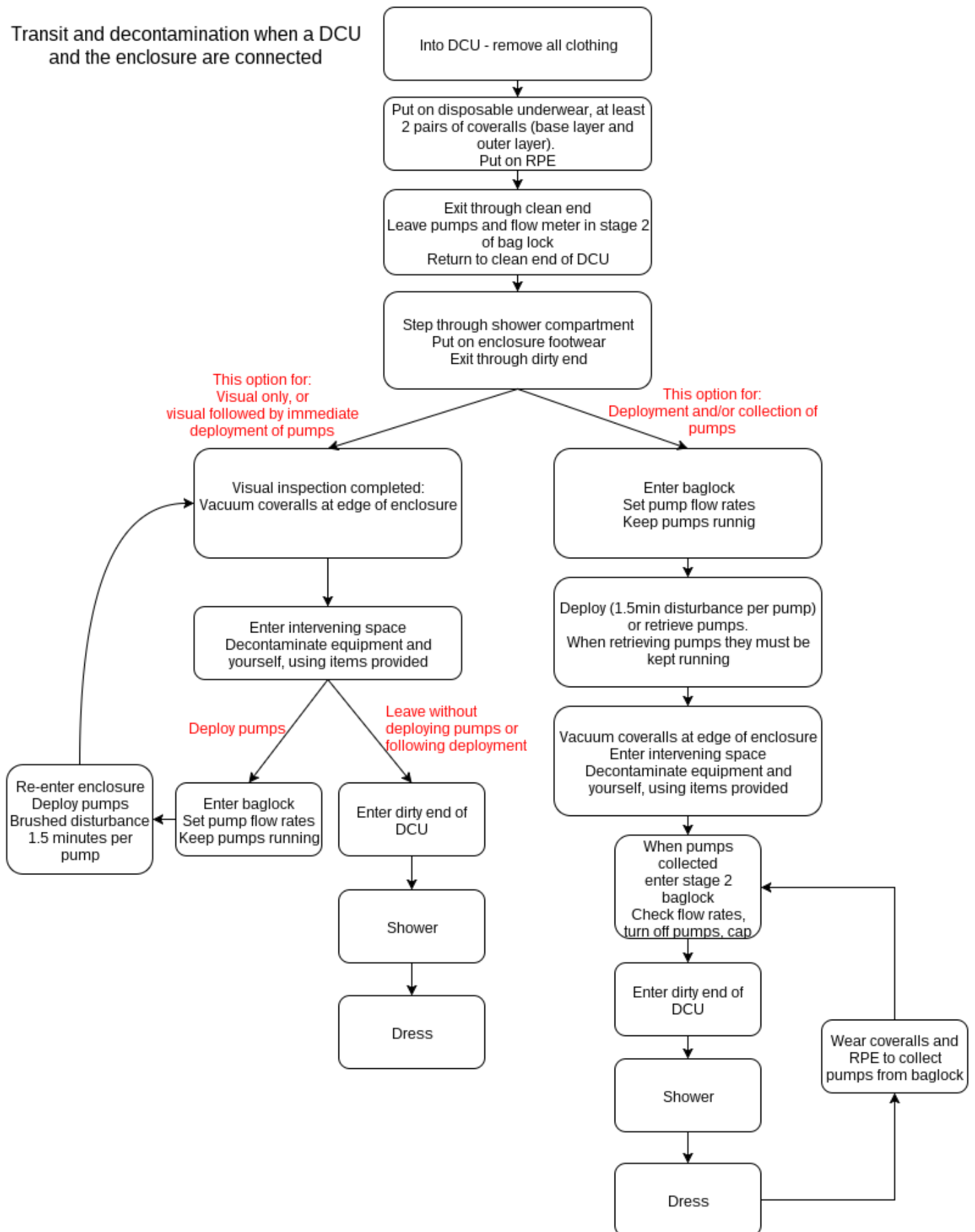



6.3 Decontamination Unit Clearance process

Inspection and clearance testing of Decontamination unit

Inspect and sample

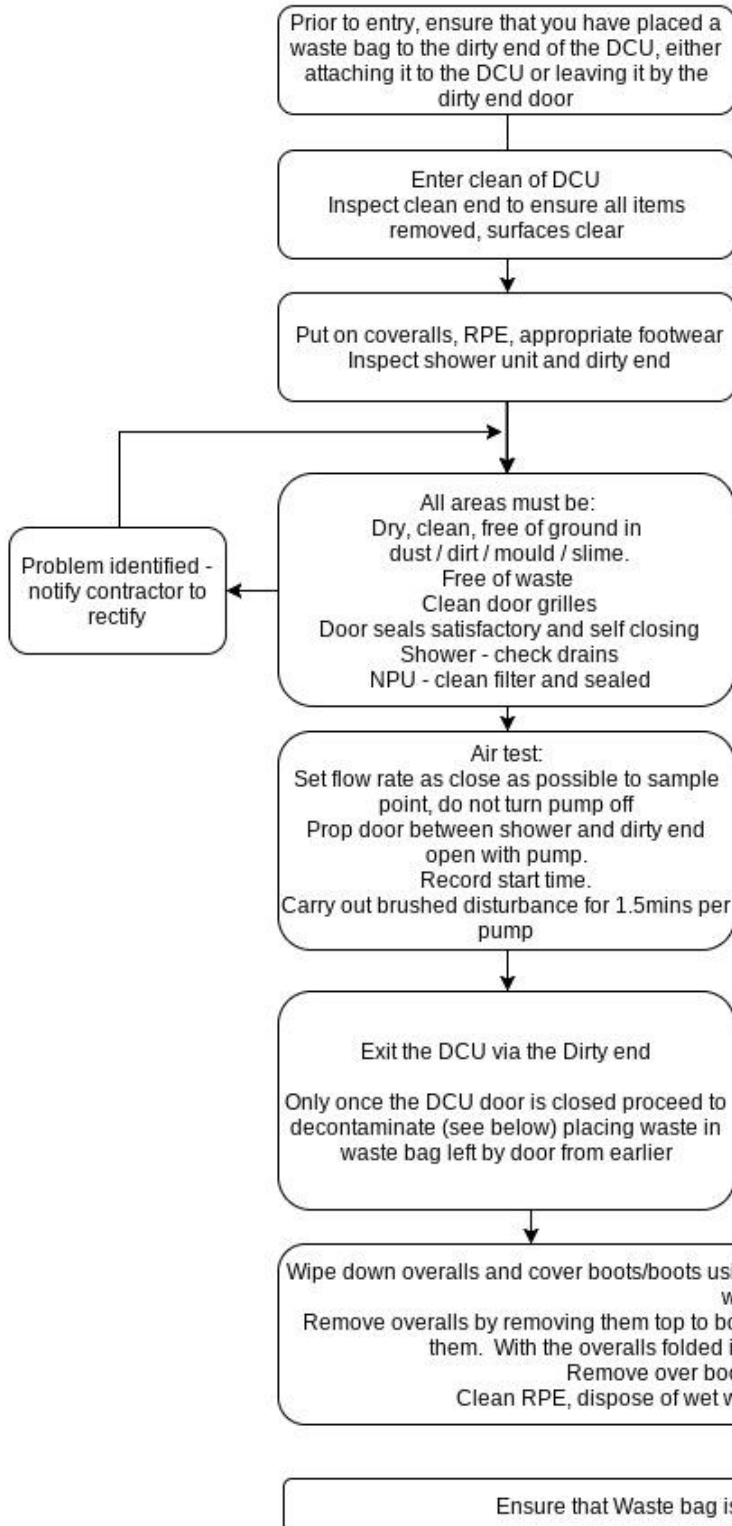

Sample retrieval and analysis

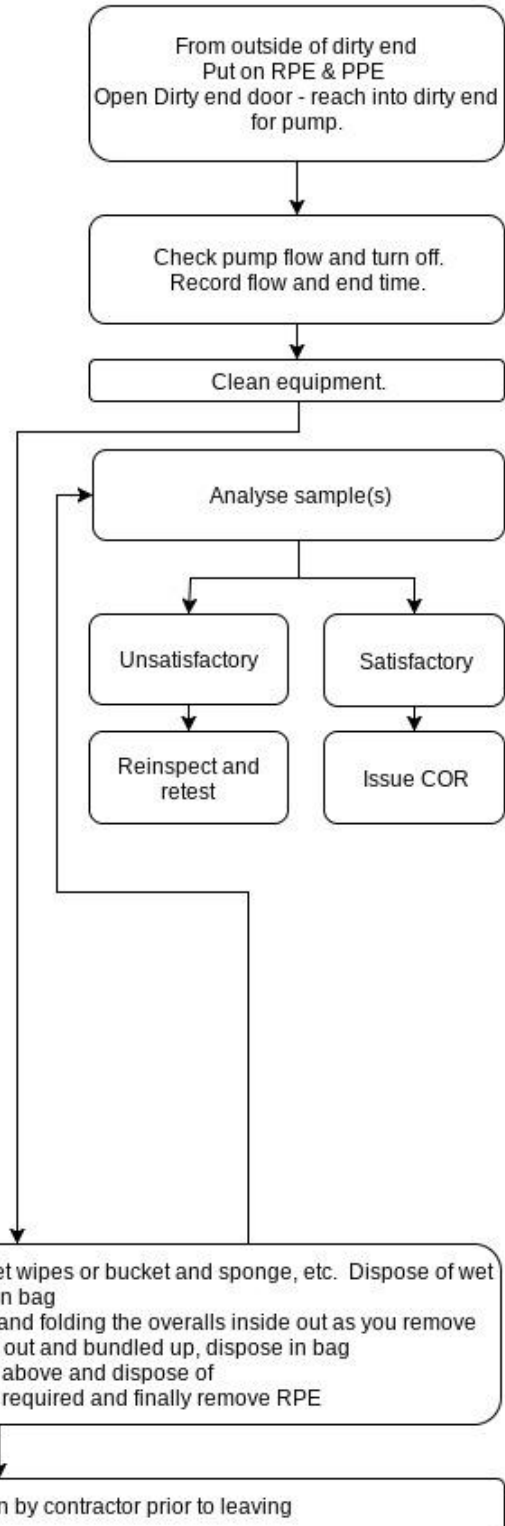

Inspection and clearance of DCU 20170710



6.4 Non-Licensed Transit and Decontamination Process

Decontamination for non-licensed removals where there is no DCU on site

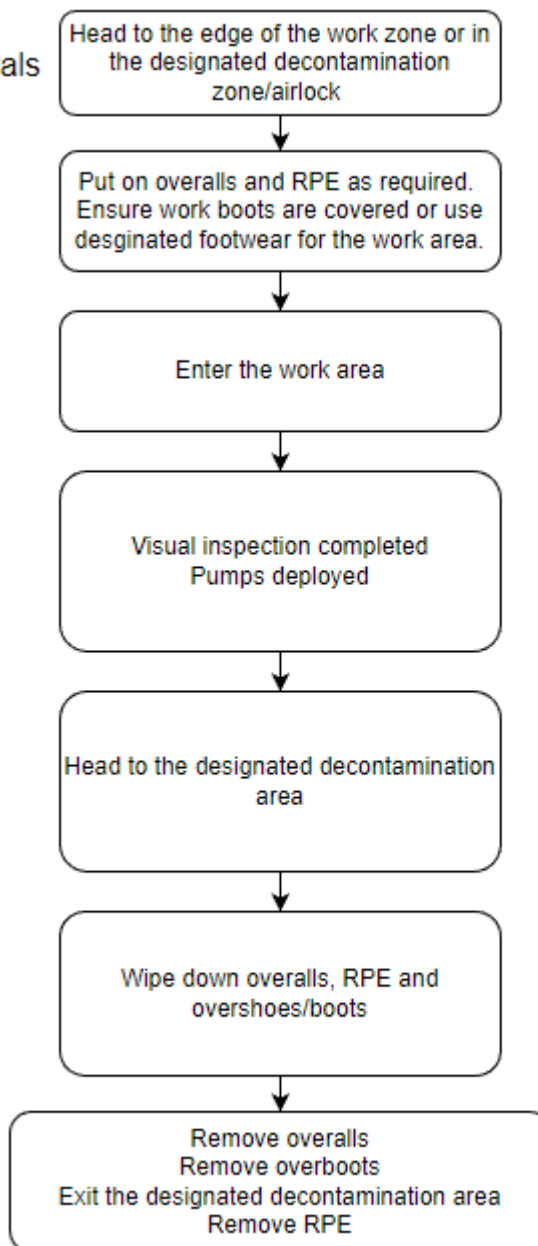



6.5 Pump flow check - via [My Profile](#)

Calibrate :: Flow Pump

TOP02.08 (5.3.1)

ID		
--		
Master Asset		Asset
search	id	SP86 - JD Technical Standard static 16ltr air pump - High Flow Pump 1062
Date		
YYYY-MM-DD		
Calibration category		
Flow Pump		
Flow rate reading		
Start flow rate	Mid flow rate	End flow rate
Total flow time		

End of document



LucionServices

Protecting people and planet

TOP02.02.09.03 SEM Procedure for identification and quantification of asbestos fibres on filter paper

Author
N. Byron

Approver
C. Parr

Revision date
08 June 2022



Table of Contents

- [1.0 Purpose](#)
- [2.0 Scope](#)
- [3.0 References](#)
- [4.0 Definitions and Abbreviations](#)
- [5.0 Specific Procedures](#)
 - [5.1 Introduction](#)
 - [5.2 Selection, Training and Authorisation of Personnel](#)
 - [5.3 Sample Preparation](#)
 - [5.4 Fibre counting and analysis by EDXA](#)
 - [5.5 Measurement uncertainty](#)
 - [5.6 Sample retention](#)
 - [5.7 SEMS PT and internal QC](#)
 - [5.8 Quantification of fine asbestos fibres in soil](#)
 - [5.9 Identification and Quantification of fibres in Gypsum](#)
- [6.0 Tables](#)
 - [6.1 Schematic examples illustrating fibre counting rules \(Figure 8, VDI 3492\)](#)
 - [6.2 Spectra of the three common regulated asbestos types \(from ISO14966\)](#)
 - [6.3 Inhouse asbestos standards spectra \(from IOM reference samples\).](#)
 - [6.4 Specific characteristics of asbestos types \(from Table D1, VDI 3492\)](#)
 - [6.5 Examples of common non-asbestos fibres](#)
 - [6.6 Asbestos density for quantification of fine asbestos fibres in soil as per Badollet, 1951](#)
 - [6.7 Fibre counting table and density calculation \(fmm2\)](#)
 - [6.8 SEM Asbestos Fibre Counting Test Certificate](#)

Unless stated explicitly in relation to a particular aspect, this policy applies to all activities delivered by the Lucion Group Limited companies, inclusive of:

- **Lucion Services Limited (including Lucion Environmental, Lucion Infrastructure and Lucion Marine)**
- **Lucion Consulting Ltd**
- **Delta-Simons Ltd**

The Lucion Group companies operate an integrated management system for all policies and procedures in line with our certifications and accreditations, offering a streamlined service to our clients.

1.0 Purpose

- 1.1 This procedure sets out the steps needed to quantify and identify asbestos fibres collected onto filter paper using Scanning Electron Microscopy



2.0 Scope

- 2.1 It applies to all personnel performing the test to identify the type of asbestos fibres present and the quantity of asbestos fibres as f/mm² or f/ml using the Scanning Electron Microscope.

3.0 References

- 3.1 Tescan Vega 3 manual
- 3.2 HSG 248: The Analysts Guide
- 3.3 Oxford Instruments Aztec Instruction Manual
- 3.4 Control of Asbestos Regulations 2012
- 3.5 TOP02.08 Procedure for asbestos air sampling
- 3.6 ISO14966:2019 Determination of numerical concentration of inorganic fibrous particles — scanning electron microscopy method
- 3.7 VDI3492 Measurement of inorganic fibrous particles Scanning electron microscopy method
- 3.8 LAB 30 edition 3
- 3.9 TOP02.09.01 and TOP02.09.02
- 3.10 MDHS 87 Methods for the Determination of Hazardous Substances
- 3.11 TOP01.03.01

4.0 Definitions and Abbreviations

- 4.1 SEM Scanning Electron Microscope
- 4.2 EDS Energy dispersive Xray spectroscopy
- 4.3 SEM PT - SEM proficiency testing scheme

5.0 Specific Procedures

5.1 Introduction

- 5.1.1 This procedure will be carried out only in the SEM laboratory and prep room. Personnel must be trained to carry out this operation and a track of this must be made in their training record.
- 5.1.2 Sample Traceability: samples arrive at the laboratory and are booked into the NexGen system.
- 5.1.3 Samples collected on filter papers will be in accordance with TOP 02.08. However, the volume of the air sampled should be in the region of 1440 litres to ensure the detection limit of 0.0005 fibres per cm³ is achieved. The preferred media for collection of airborne fibres for analysis by SEM are pre-loaded gold coated 0.8 µm pore diameter and 25 mm diameter filters. Alternatively 25 mm 0.8 µm cellulose nitrate filters can be used. However if the sample is taken using an untreated cellulose nitrate filter, using an non-disposable sampling head, care must be taken so that any fibres on the filter paper are not lost during transportation. The filter paper should be placed inside a petri dish and attached with tape to a very small portion of the unused outer edge of the filter paper. This will prevent the exposed surface of the filter having direct contact with any other surface and losing fibres during transportation. The petri dish should then be taped externally for transport.
- 5.1.4 Sample Preparation: samples will be prepared for SEM analysis dependent upon the sample collection



method in accordance with TOP02.09.01. The status and condition of the sample should be noted in the NexGen notes prior to sample prep

- sample arrives in disposable sample head on pre prepared gold coated polycarbonate filter
- sample arrives on untreated cellulose nitrate filter.

5.1.5 Sample preparation is described below.

5.1.6 Scanning: samples will be scanned in the Tescan Vega 3 Microscope following the protocol for analysis and counting outlined below

5.1.7 Reporting: results will be recorded in the SEM fibre Counting form and uploaded onto the NexGen system

5.1.8 Retention of samples: sample will be retained for a period of 6 months from analysis

5.2 Selection, Training and Authorisation of Personnel

5.2.1 Staff will be trained according to SOP 01.03 before being authorised to analyse samples using SEM.

5.2.2 During training, staff may observe and carry out tasks under the supervision of an authorised SEM analyst

5.2.3 Staff authorised to analyse membrane filters for the presence of asbestos fibres will hold the BOHS P403 certificate and will have attended training relating to the use of the SEM and EDS provided either by the manufacturer of the equipment or inhouse authorised analysts.

5.2.4 Prior to authorisation, staff will have completed all necessary training , completed 5 SEM QC samples and successful witnessed audit as outlined in SOP01.03

5.3 Sample Preparation

5.3.1 A proportion of filters as described below are checked to ensure that they have a uniform pore distribution and the background level of fibres is sufficiently low so as not to influence the results:

- Pre-loaded gold coated filter in disposable sampling head: 1 filter per batch of 50 heads
- Loose gold coated filters: 1 sample per batch of 100 filters
- Cellulose nitrate filters: 1 per batch of 100 as described in TOP02.09 (only contamination check)

5.3.2 Plasma Ashing: The SEM procedure requires that all organics are removed in order to facilitate counting using the WHO rules. Pre-loaded gold coated filters are surface etched in O₂ at approximately 20W for 5 minutes, cellulose nitrate filters filters are surface etched in O₂ at approximately 20W for 20 minutes, this removes the organic material leaving the asbestos fibres and inorganics exposed for SEM examination. Refer to TOP02.09.01

5.4 Fibre counting and analysis by EDXA

5.4.1 Operation of the SEM shall be carried out in accordance with the Vega 3 instruction manual and operation of the EDS in accordance with course instruction.



5.4.2 The operating conditions for the analysis are described below. The instrument setup/calibration checks are to be conducted each day before analysis is commenced as described in the ISO 14966 method Annex B. A reference sample will be used to enable checks to be carried out. Once all checks satisfactory a two images of fibres and accompanying spectra will be retained on the drive [SEM calibration checks folder](#).

5.4.2.1 The operating conditions for the SEM micrograph acquisition should be:

- electron beam (HV) - 15kV
- beam intensity - 12
- scanning mode - resolution
- scanning speed - in the region of 4-5
- detector - SE
- magnification - 2070:1
- view field - 100 μm
- working distance (WD) - in the region of 15 mm

5.4.2.2 The operating conditions for the EDS assessment should be:

- electron beam (HV) - 15kV
- beam intensity - 12
- scanning mode - resolution
- scanning speed - 4
- detector - SE
- magnification - in the region of 10000:1
- working distance (WD) - in the region of 15 mm
- process time 5 - to ensure analysis within 100 seconds with a total count at 60 000 on a reference sample (0.2 μm wide chrysotile fibre as per ISO 14966 Annex B)

5.4.3 The exposed filter surface is assessed to ensure even distribution of particles across the filter. Where distribution is inhomogeneous the filter shall not be used for quantitative analysis.

5.4.4 120 points (area of each point is 0.01mm²) are marked at random using the Image Snapper programme and 120 micrographs produced. This gives an analysed area of 1.2mm². Micrographs are stored into a file with the unique job number.

5.4.5 Micrographs are carefully analysed to find countable fibres (>5 μm length, <3 μm width, with a length to width ratio of at least 3:1). By clicking onto the micrograph the SEM will return to the area scanned and a “live” image of the micrograph will appear. Using this “live” image and increasing the magnification to about 10000x the fibre dimensions are measured and recorded. The analysis is possible on the principle that the sample is not removed from the chamber. Micrographs containing the measurement bars are saved to the job file. Using the Oxford Instruments Aztec system and Energy Dispersive Spectroscopy (EDS/EDX) the fibre is identified against a spectrum analysis of a known standard asbestos type (definitive spectral analysis of the IOM supplied samples of the six regulated asbestos types is used as the reference and shown in 6.3).

5.4.6 During analysis fibres are counted in accordance with the WHO fibre counting rules and as shown schematically in 6.1.

Additionally, the following shall apply:



- Fibres with both ends in the micrograph are counted
- Fibres with only one end in the image field are counted and given the weighting 0.5
- Fibres with both ends outside of the image field are not counted
- If more than one eighth of the area of an image field is obscured or overloaded with particles/fibres, that field shall be rejected
- If more than 10% of the image fields are rejected, the entire sample shall be rejected.

5.4.7 Geometric and morphological criteria:

- As per HSG248 guidance asbestos is recognised by the fineness of its fibres which often are present in closely packed bundles of fibrils that divide along their length. The amphibole minerals which form asbestos also occur in non-fibrous forms, however, the asbestos regulations only apply to the asbestos forms of the minerals.
 - a range of aspect ratios ranging from 20:1 to 100:1 or higher for fibres longer than 5 µm;
 - capability of splitting into very thin fibrils;
 - two or more of the following:
 - ❖ parallel fibres occurring in bundles;
 - ❖ fibre bundles displaying frayed ends;
 - ❖ fibres in the form of thin needles;
 - ❖ matted masses of individual fibres; and/or
 - ❖ fibres showing curvature
- Count fibres meeting the definition of a countable fibre
- A split fibre shall be included if it meets the definition of a countable fibre
- If individual fibres can be distinguished in a bundle, they shall be counted individually
- If individual fibres cannot be distinguished in a bundle, the bundle shall be counted as a single fibre if the bundle complies with the definition of a countable fibre. Unresolved fibre bundles shall be recorded in the fibre count form
- Where contacting fibres conceal the end of another fibre, only the visible part of the fibre is included in the measurement.

5.4.8 Fibre classification is based on the EDS spectra with the classification rules as per MDHS 87

Fibres are classified on the basis of the comparison of their EDX spectrum with spectra collected from reference standards analysed using the same SEM operating conditions. The same types of strategies can be applied as for discrimination by light microscopy. SEM-EDS is limited in its ability to discriminate by the quality of the EDS spectrum generated. The morphology of the fibres is also important and must be considered at all times in combination with the EDS spectrum.

A fibre is counted as asbestos if:

- the EDS spectrum is effectively the same as that of a reference asbestos type;
- the EDS spectrum has the same elements as a reference asbestos type but the elemental X-ray proportions differ by up to ±30%;



- the EDS spectrum contains elements typical of a reference type but also contains elements from a known contaminant dust;
- the fibre diameter is too small to produce an EDS spectrum (0.20 µm or less).

A fibre is counted as a non-asbestos fibre if:

- the fibre is >0.2 µm diameter and contains no major metal elements or silicon;
- the EDS spectrum contains some or all of the elements found in one of the reference types but the proportions are very different, eg high Ca, very low Si, very low Mg;
- the EDS spectrum contains high proportions of elements that are not found in any of the reference asbestos types and there are no signs of obvious contamination of the fibre, eg very high Fe, very low Si

5.4.9 Fibres are classified as follows:

- asbestos
 - chrysotile (C) - as per MDHS 87 - chrysotile is usually found as fine fibres (curly or straight) with diameters <1µm. The fibres often display splitting at the ends and often occur in bundles. When examined at high magnification their fibrillar nature may be seen. The EDXA spectrum shows peaks for magnesium and silicon in the approximate height ratio 3:4/Mg:Si; also a very small iron peak may be seen.
 - amphibole asbestos (A) - as per MDHS 87 - normally amosite or crocidolite, occasionally anthophyllite, actinolite and tremolite. Generally the amphibole asbestos minerals are parallel sided, needle-like or lath-shaped, fibres with aspect ratios >10:1 (sometimes up to 100:1). Fibres with widths >1µm usually show splitting at the ends, occur in bundles and show gentle curving (without sharp angular bends). Usually in airborne dust samples fibres are <1µm in diameter and appear straight with parallel sides.
- calcium sulphate (gypsum) (CS)
- other inorganic fibres (including MMMF) (I)

5.4.10 Each measured and classified fibre is recorded in the Fibre counting table (6.5)

5.4.11 Density of fibres on the filter paper in fmm² is calculated using the following equation:

$$d = f/FA$$

where:

d = the fibre density (in fibres per mm²)

f = the number of fibres counted

F = the number of fields evaluated

A = the area of a single field (mm²)



5.4.12 Where a known volume of air has been drawn through the filter paper the following shall be applied in order to calculate the airborne concentration of fibres in fcm^{-3} .

$$C_i = \frac{n_i}{V_p}$$

$$V_p = \frac{V \cdot N \cdot F_b}{\Pi \cdot (d_{eff}/2)^2}$$

where:

C_i = numerical fibre concentration of fibre class i

n_i = number of fibres of class i

V_p = evaluated volume of air sampled

N = number of image fields examined (120 - fields rejected)

F_b = area of an image field (0.01mm^2)

V = sampled air volume (l)

d_{eff} = effective filter diameter (22.5mm^2 for pre loaded sample heads)

5.4.13 Detection limit (E) can be calculated based on the 95% probability as described in VDI3492 using the following equation:

$$E = \frac{3}{V_p}$$

where:

E = detection limit

V_p = evaluated volume of air sampled

5.4.14 All calculations and results are reported in the SEM Asbestos Fibre Counting Test Certificate (6.7) and stored as a pdf in the applicable NexGen job.

5.4.15 Micrographs of all assessed fields are stored locally on the SEM machine. The folder can be also copied to the applicable job in NexGen if requested.

5.4.16 Termination of counting - counting can be terminated if one of the below conditions is fulfilled:

- area of 1.2 mm has been assessed, i.e. 120 micrographs
- The 50th inorganic fibre (other than calcium sulphate fibres, including asbestos fibres) occurs. If, after examination of 50 image fields, 50 fibres have not been detected, further fields shall be examined until either a total of 50 inorganic fibres has been counted or sufficient area has been examined to achieve the desired analytical sensitivity.



- over 10% of the micrographs have been rejected - filter is reported as unsuitable for counting. Continue the examination until completion of the field in which the 50th inorganic fibre (other than calcium sulphate fibres, including asbestos fibres) occurs. If, after examination of 50 image fields, 50 fibres have not been detected, further fields shall be examined until either a total of 50 inorganic fibres has been counted or sufficient area has been examined to achieve the desired analytical sensitivity. For most applications, it is recommended that at least 1 mm² of the filter area be examined. Fibre counting can be terminated early with respect to a fibre type as a function of a limit or guide value K_R (fibres per m³). If more than N_A fibres of this type have been found fibre counting can be terminated. N_A is calculated as follows:

$$N_A = \frac{3 \cdot K_R \cdot V'_S}{F_A}$$

where

N_A is the fibre number of a specific type;

K_R is the benchmark or limit to be tested, in m⁻³;

V'_S is dependent from V_S the sampled volume of air per filter area:

$$V'_S = 1 \text{ m}^3/\text{cm}^2 \text{ for } V_S \leq 1 \text{ m}^3/\text{cm}^2;$$

$$V'_S = V_S \text{ for } V_S > 1 \text{ m}^3/\text{cm}^2;$$

F_A is a constant (= 100 cm⁻²).

5.4.18 As per ISO 17025 and SOP01.11 when it is necessary to issue a complete new test report due to additional samples taken, the new report will be uniquely identified and shall contain a reference to the original that it replaces.

5.5 Measurement uncertainty and limit of detection

5.5.1 ISO14966:2019 section 8.2 describes and calculates measurement uncertainty associated with this method of determining the concentration of inorganic fibre particles by SEM. We have calculated uncertainty associated with the measurement of a fibre dimension at <3%. Validation of the Lucion method has been carried out by comparison of analytical results with those of UKAS Accredited Testing Body 0374 which also applies the ISO14966:2019 methodology. This validation has demonstrated that our method and the results achieved are comparable (<1 ESD) to testing Body 0374, therefore, we can use the proceeding data as an equivalent measurement of uncertainty.



5.5.2 It considers:

- systematic errors
 - sampling
 - SEM specimen preparation
 - analysis
- random errors
 - particularly important for low fibre counts

5.5.3 Sampling errors - a relative standard deviation was determined to be:

$$2\sigma_p < 15\%$$

5.5.4 SEM examination errors - a relative standard deviation was determined to be:

$$2\sigma_A \leq 35\%$$

5.5.5 Subjective error of the operator - a relative standard deviation was determined to be:

$$2\sigma_{SF} = 15\%$$

5.5.6 Total error of the measurement was calculated:

$$\sigma_T = \sqrt{\sigma_p^2 + \sigma_A^2 + \sigma_S^2}$$

where

- σ_T is the standard deviation for the overall measurement
- σ_S is the standard deviation for sampling errors
- σ_A is the standard deviation for analysis errors
- σ_p is the standard deviation for Poisson variability

5.5.7 The standard deviation for the combination of sampling and analysis is calculated from σ_p and σ_A to give:

$$2\sigma_V \leq 38\%$$

5.5.8 Random errors - assuming numerical fibre concentrations are low, the probability of detecting fibres can be described using the Poisson distribution - Table 2, ISO14966 and reproduced in this document as Table 6.9.

5.5.9 Limit of detection is defined as the numerical concentration below which, with 95% confidence, the actual fibre concentration lies when no fibres are detected during the SEM examination.

5.5.10 Detection limit, E, is calculated in accordance with ISO14966:

$$E = \frac{2.99}{N.V_B}$$

For each sample analysed the above is applied and the Certificate of Analysis states:

‘Detection limit is reported as the numerical fibre concentration below which, with 95% probability, the actual concentration lies when no fibres are detected. Detection limit depends on sampled volume of air and the examined filter area. Detection limit is determined in accordance with ISO14966.’

5.5.11 The Uncertainty of Measurement for BIA 7487 method used for analysis of asbestos in Gypsum has reported the following:



Measurement uncertainty and detection limit are essentially determined by the condition of the sample material (particle size, homogeneity), the care in suspension and filter specimen preparation, the density and uniformity of filter stacking and the care in asbestos fibre identification and measurement as well as by Poisson statistics. In this regard we provide below benchmarks that can be attained for the suspended sample under usual working conditions and when analyzing 0.5 mm² of filter area.

At a mass content of 0.1% of asbestos fibres in the suspended sample, the measurement uncertainty is about 0.07% to 0.16%, at 0.05% about 0.03% to 0.09% and at 0.01% about 0.003% to 0.03%.

The detection limit for 0.5 mm² of evaluation area and under simplistic assumptions is estimated to be 0.008%. This means: if no asbestos fibre is found on the 0.5 mm² filter area, the mass content of asbestos fibres in the suspended sample ought to be under 0.008%.

5.6 Sample retention

5.6.1 Samples are retained in the dedicated archive system for a period of 6 months from analysis, unless specifically requested by the client.

5.7 SEMS , LACS PT and internal QC

5.7.1 A control of inter laboratory comparability is maintained by the laboratory participating in the HSL SEMS & LACS schemes . All authorised SEM fibre counters and trainees (where possible to gain experience) will count the number of samples specified by the scheme. Each analyst shall analyse a unique set of 120 images collected by the Image Snapper programme. Results will be passed directly to the Quality Manager for collation and compliance according to SEMS requirements.

5.7.2 Results Analysis/Corrective Measures. The quality manager will assess the results when received from SEMS / LACS and inform the counters accordingly.

5.7.3 A set of internal quality control samples (already mounted on stubs) that were either initially supplied for the SEMS, validated internally or internal air tests that have also be analysed by IOM, are kept by the Lab Manager who shall issue one of these each month to authorised and trainee SEM counters and ensure that monthly QC's include both amphiboles and serpentine with various fibre densities. Monthly QC stubs shall cover the range of analysis required and shall include air filters/ soil / gypsum. Each analyst shall analyse a unique set of 120 images collected by the Image Snapper programme. The results will be submitted to the Quality Manager for assessment/comparison with the results detailed on the system.

5.7.4 It is expected that total counts of these quality control samples fall within Bands A and B as described in the



RICE scheme and as applied in SEMS or within the Z score ± 2 as applied for LACS. Additionally, the identification of the fibres by EDX (amphibole, chrysotile and inorganic fibres) will be assessed to ensure that the calculated density of fibres observed also meets the banding criteria of the RICE scheme. The densities of each fibre type will be recorded in SEM QC Data Checker.

Where C counts are achieved, investigation will be necessary to determine the cause and the retraining will be given.

5.7.5 Each SEM analyst will be given quality control samples as detailed below:
monthly:

- 2 bulk QC library samples
- 1 soil QC library sample
- 1 soil QC library sample for quantification
- 4 internal fibre QC
- 1 SEM QC analysis (to include gypsum sample stubs)
- 1 SEM random cross-check of a colleague's sample

as the scheme dictates:

- AIMS
- AISS
- RICE
- SEMS
- LACS

5.7.6 One random routine sample per month will be re-assessed by a second analyst and the result compared with the original count. The sample is aimed to be representative of the work undertaken by the analyst. These counts shall be recorded in the SEM Cross Counting spreadsheet to determine whether the two counts are within the estimated standard deviation; if they are not, then an investigation shall be carried out by the Quality Manager

5.7.7 The SEM and EDS service is to be done annually and will contain the following documents saved in dedicated folder:

- Screen area calibration image,
- EDS line measurement calibration image,
- EDS calibration image.

Measurements are to be performed using Lucion owned certified silicon specimen (Spec No. B615)

5.8 Quantification of fine asbestos fibres in soil

5.8.1 The TOP01.03.01 will be followed to produce a cellulose nitrate filter to be analysed by SEM.

5.8.2 Cellulose nitrate filter will be prepared according to TOP02.09.01.

5.8.3 Standard analysis steps as described in 5.4.

5.8.4 Countable fibre criteria for the soil quantification are $>5\mu\text{m}$ length, $<5\mu\text{m}$ width, with a length to width ratio



of at least 3:1.

5.8.7 The exact dimensions of each fibre is recorded and the approximate volume is counted based on the equation

$$V=\pi r^2 *h$$

where:

r = radius of the fibre

h = length of the fibre

5.8.8 The mass of each the fibre identified as asbestos is estimated based on the standard density of the asbestos minerals as per table 6.6. Due to the method recognising asbestos as chrysotile and amphibole asbestos fibres the density for chrysotile fibres is counted at 2.5 g/ml, all amphibole asbestos fibres are counted at 3.1 g/ml.

Sum of the weight of all asbestos fibres is counted and the mass of the total asbestos weight per subsample is calculated.

5.8.9 The LOD is based on the weight of the soil aliquot, the accuracy of the scales used (calibrated balances to 4 decimal places), and micro-pipette and nozzles.

5.8.10 The result is reported in a soil quantification certificate and added to the mass asbestos as a density of free fibres in fine fraction of analysed soil.

5.9 Identification and Quantification of asbestos fibres in Gypsum

5.9.1 Sample Preparation: On receipt, the entire sample (if appropriate) will be crushed, sieved then depending upon sample size may be reduced in size by the cone and quarter method or if the sample is too large, 10 random scoops of approx 2.5g may be taken from the sample within the HEPA cabinet. The resulting sub-sample size should be approximately 20 - 25g

5.9.2 From this sub-sample, randomly select approximately 1 g of powder, if individual particles are visible then crush using pestle and mortar, applying minimum pressure to the pestle in order to obtain a homogeneous particle size. If the particle size remains non-uniform, the ground powder will be passed through a 100µm mesh sieve , any residue too large to pass through the sieve will then be further crushed until the entire sample has passed through the sieve)

5.9.3 Between 10mg and 50mg of the prepared sample is then randomly selected. This will be accurately weighed using the 4 decimal place balance and weight recorded. This will then be suspended into 500ml of demineralised filtered water.



- 5.9.4 The suspension is then thoroughly mixed for several minutes using the ultrasonic bath.
10ml-50ml are immediately pipetted off and filtered through a gold coated nuclear pore filter (polycarbonate Filter, 25mm diameter, 0.8µm pore size, gold layer approx. 40nm thick on the glossy front approx. 20nm thick on the back)
- 5.9.5 The filter will be prepared according to TOP02.09.01 followed by Standard analysis steps as described in 5.4.
- 5.9.6 Contract Review will determine the level of analysis required ie Identification only or Identification and quantification. If Quantification is requested Contract review shall also determine if the client requires the fibres to be counted against WHO countable fibre criteria >5µm length, <5µm width, with a length to width ratio of at least 3:1 or if all asbestos fibres are counted with no upper diameter limit. For Identification only see 5.4 of this procedure
- 5.9.8 The exact dimensions of each fibre is recorded and the approximate volume is counted based on the equation
- $$V = \pi r^2 * h$$
- where:
- r = radius of the fibre
- h = length of the fibre
- 5.9.9 The mass of each fibre identified as asbestos is estimated based on the standard density of the asbestos minerals as per table 6.6. Due to the method recognising asbestos as chrysotile and amphibole asbestos fibres the density for chrysotile fibres is counted at 2.5 g/ml, all amphibole asbestos fibres are counted at 3.1 g/ml.
- Sum of the weight of all asbestos fibres is counted and the mass of the total asbestos weight per subsample is calculated.

- 5.9.11 As per the Contract requirement following additional quantification of inorganic fibres can be undertaken.

Due to the method limited to recognising respirable fibres in just four classes

- chrysotile fibres
- amphibole asbestos fibres
- calcium sulphate fibres
- inorganic fibres.



The density for the mass of each fibre classed as inorganic shall be estimated based on the assumption of the majority of fibres present being man made mineral fibres and assessed at 2.55 g/ml

Sum of the weight of all inorganic fibres is counted and the mass of the total inorganic fibre weight per subsample is calculated.

Inorganic fibre quantification is not UKAS accredited and an appropriate entry shall be made in the report to note this.

5.9.11 The LOD is based on the weight of the powder aliquot, the accuracy of the scales used (calibrated balances to 4 decimal places), and micro-pipette and nozzles.

5.8.12 The result is reported in the format agreed at contract review



6.0 Tables

6.1 Schematic examples illustrating fibre counting rules (Figure 6, from ISO14966)

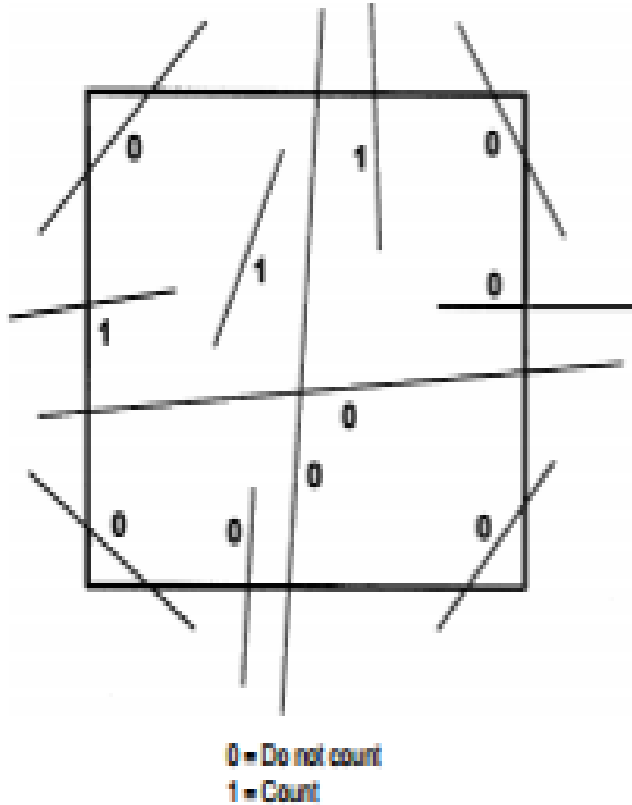
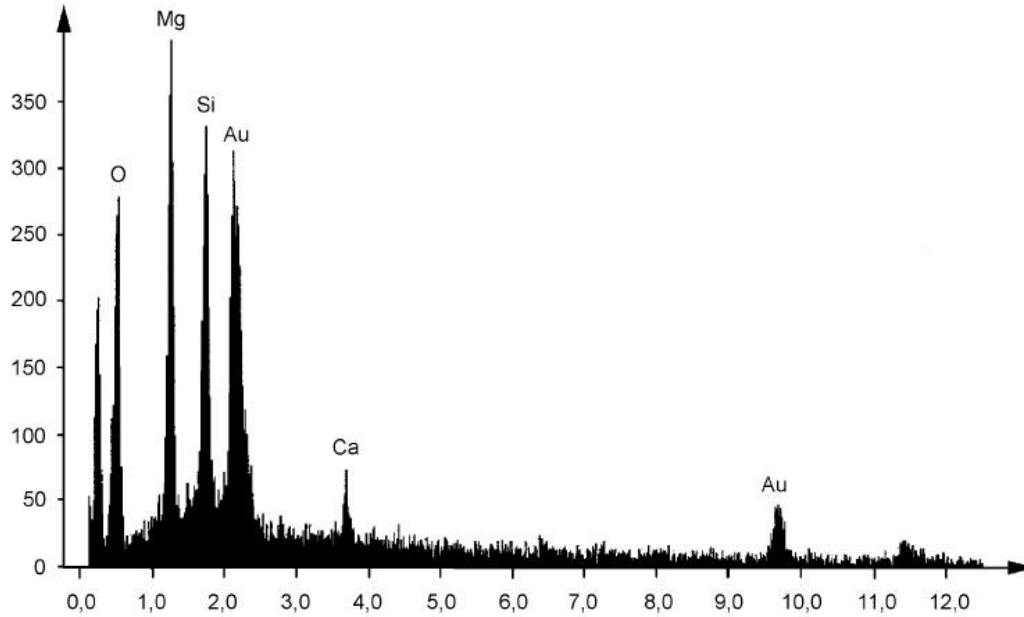

Figure 6 — Examples of fibres extending outside the image field



6.2 Spectra of the three common regulated asbestos types (from ISO14966)

6.1.1 Chrysotile



a) Fibre of chrysotile on a gold-coated filter with other particles

6.1.2 Amosite

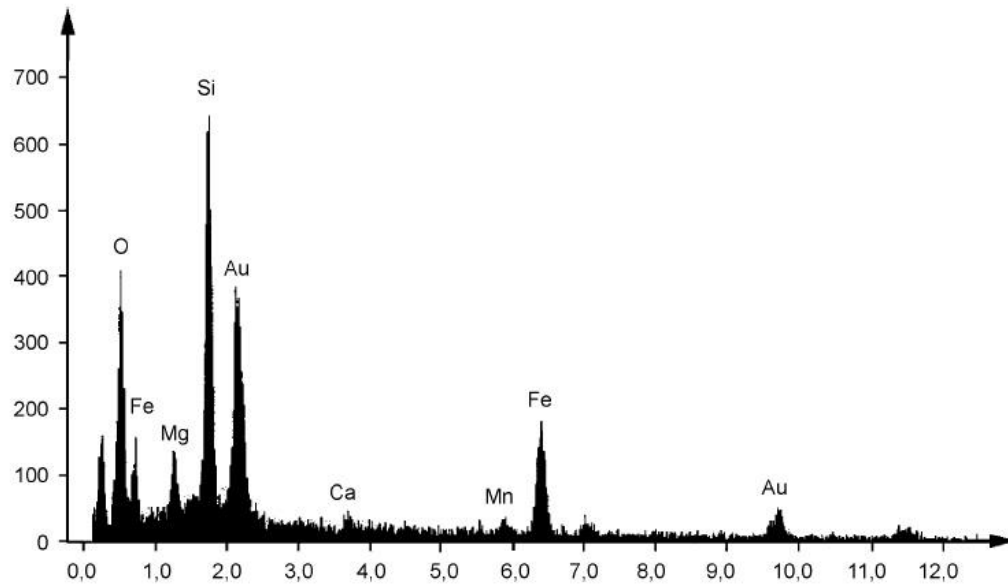

b) Fibre of amosite on a gold-coated filter with other particles



6.1.3 Crocidolite

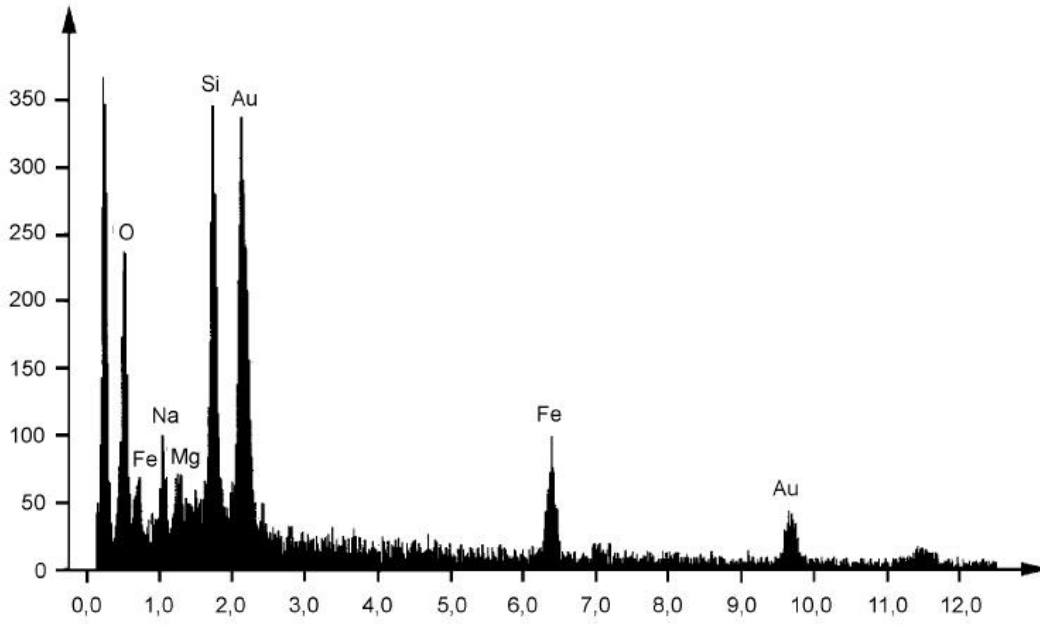

c) Fibre of crocidolite on a gold-coated filter with other particles



6.3 Inhouse asbestos standards spectra (from IOM reference samples).

Chrysotile:

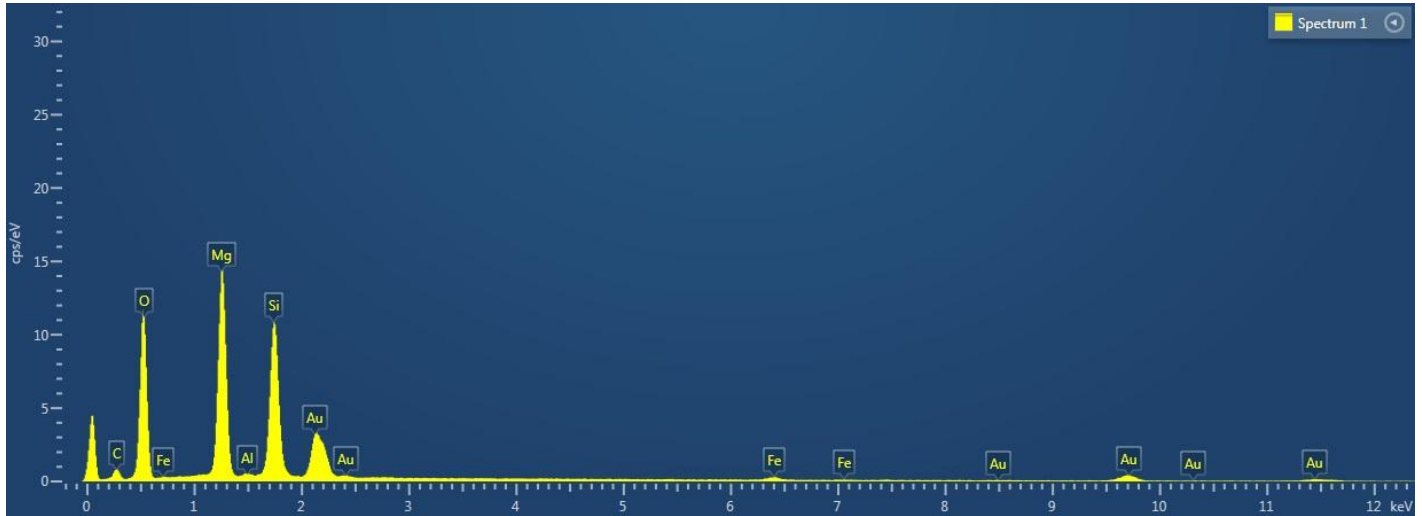

Amosite:

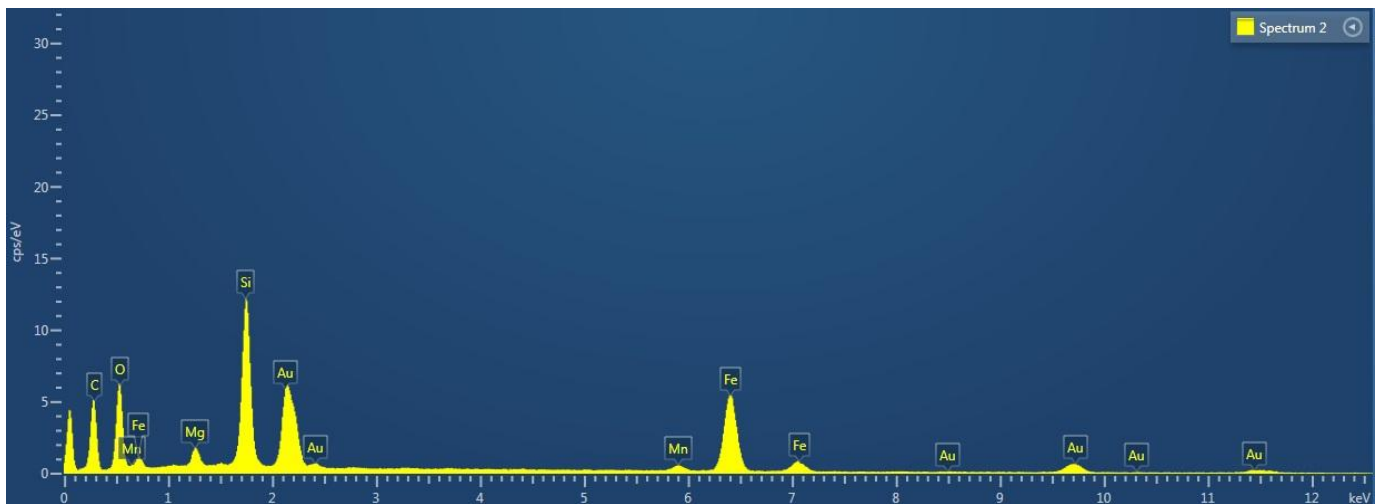



Crocidolite:

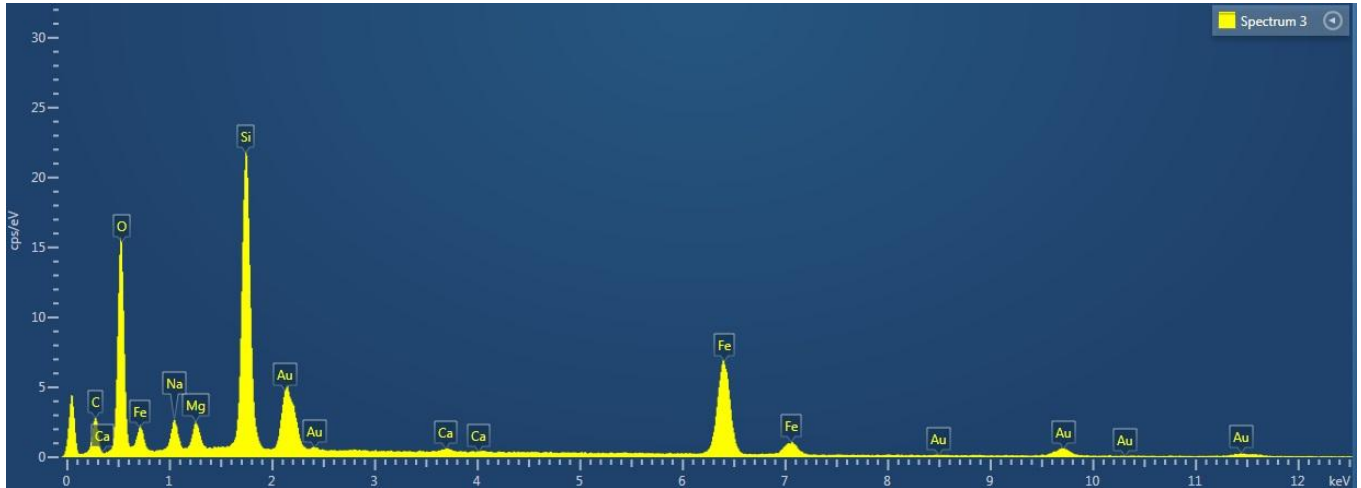

Actinolite:

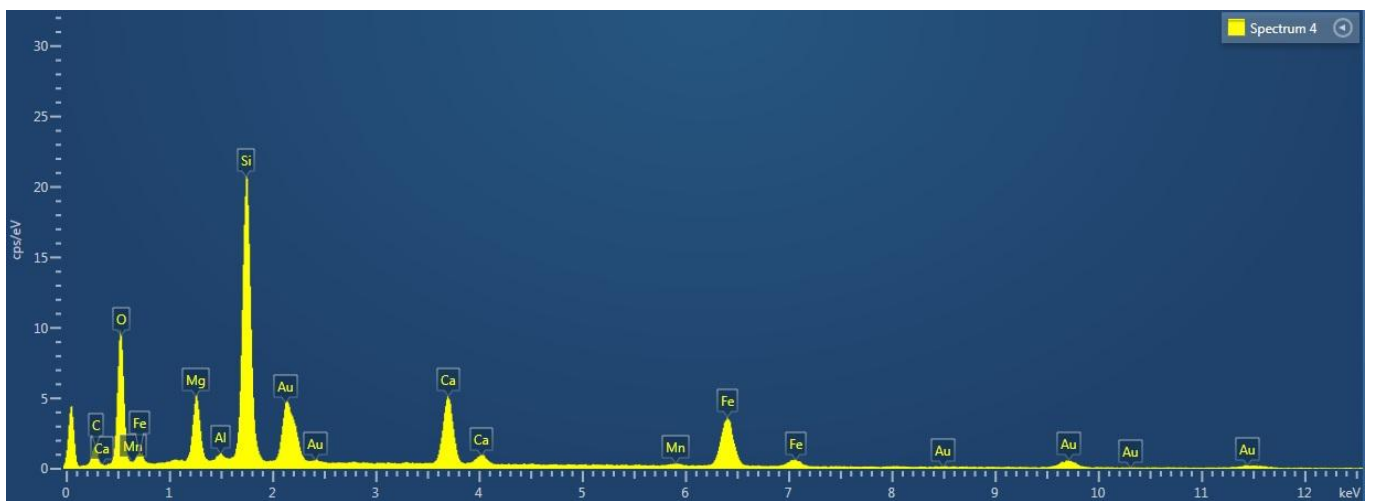



Tremolite:

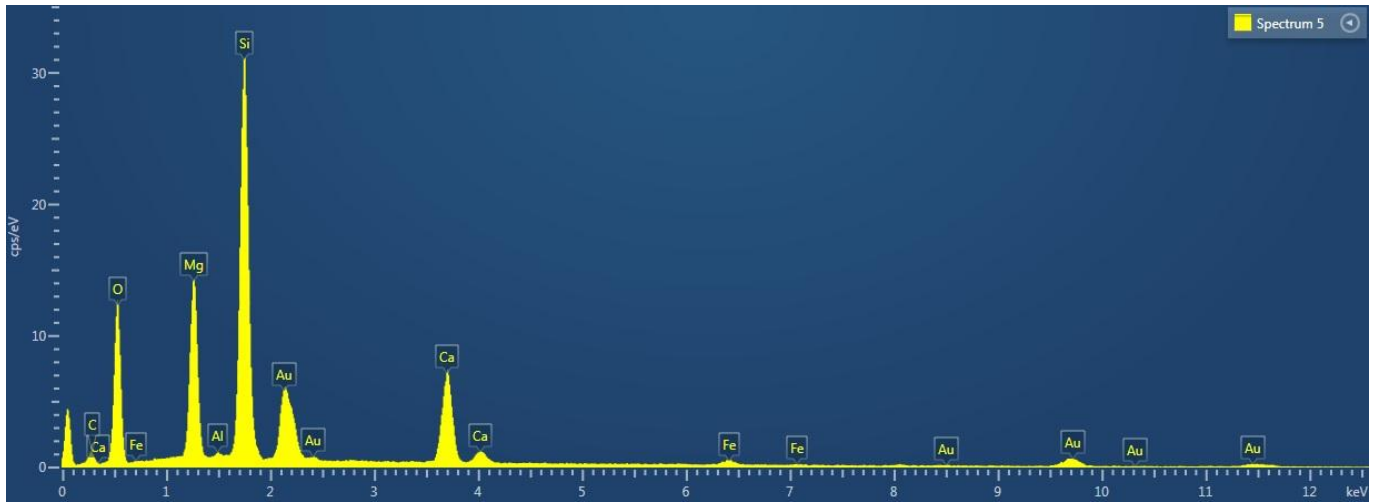

Anthophyllite:

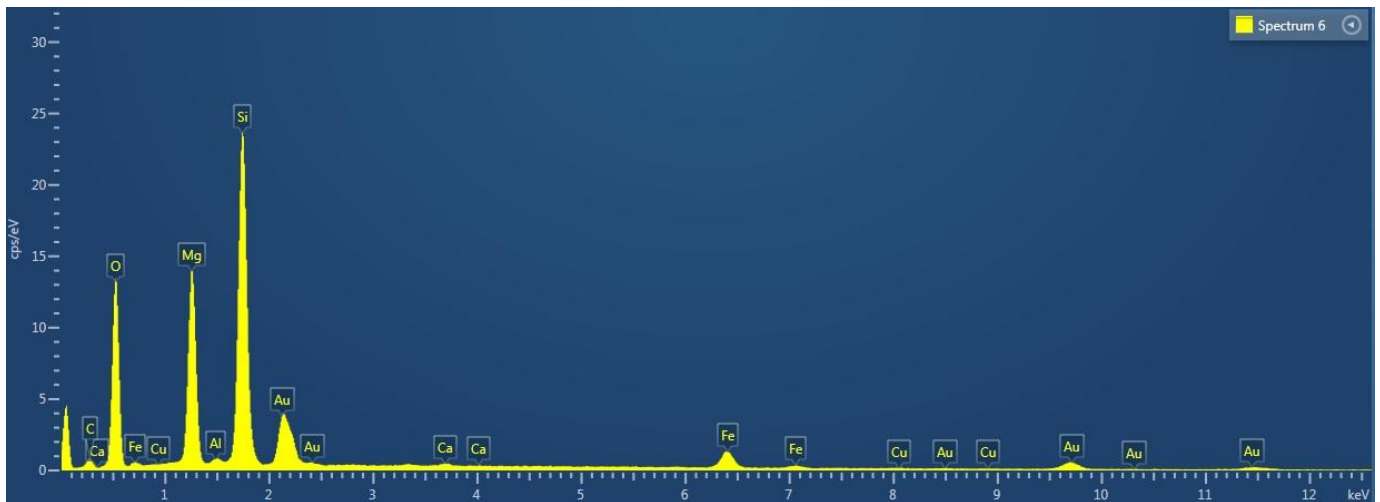



6.4 Specific characteristics of asbestos types (from Table D1, VDI 3492)

Group	Serpentine absestos	Amphibole asbestos				
Mineral	Chrysotile	Anthophyllite	Amosite	Tremolite ^{a)}	Actinolite ^{a)}	Crocidolite
Formula	Mg ₃ [(OH) ₄ Si ₂ O ₅]	(Mg, Fe) ₇ [OH/Si ₄ O ₁₁] ₂	(Fe, Mg) ₇ [OH/Si ₄ O ₁₁] ₂	Ca ₂ Mg ₅ [OH,F/Si ₄ O ₁₁] ₂	Ca ₂ (Mg,Fe) ₅ [OH,F/Si ₄ O ₁₁] ₂	Na ₂ Fe ²⁺ ₃ Fe ³⁺ ₂ [OH/Si ₄ O ₁₁] ₂
Transition temperature, in °C	450 to 700	600 to 850	600 to 800	950 to 1040	620 to 960	400 to 600
Melting temperature, in °C	1500	1450	1400	1315	1400	1200
Morphology of the fibres	fibrous twisted	fibrous, columnar or acicular		acicular, columnar		fibrous, columnar, felt-like
Acid resistance	low	very good	moderate	very good	moderate	good
Akaline resistance	very good	very good	good	good	good	good
Chemical composition, in %						
SiO ₂	36 to 44	53 to 60	49 to 53	55 to 60	51 to 56	49 to 56
MgO	38 to 42	17 to 34	1 to 7	20 to 26	12 to 20	0 to 3
FeO	0 to 3	3 to 20	34 to 44	0 to 5	5 to 15	13 to 21
Fe ₂ O ₃	0 to 5	0 to 5	0 to 5	0 to 5	0 to 5	13 to 20
Al ₂ O ₃	0 to 2	0 to 3	0 to 1	0 to 5	0 to 3	0 to 1
CaO	0 to 2	0 to 3	0 to 2	0 to 3	10 to 13	0 to 3
K ₂ O	0 to 1	0 to 1	0 to 1	0 to 1	0 to 1	0 to 1
Na ₂ O	0 to 1	0 to 1	0 to 1	0 to 2	0 to 2	4 to 9
H ₂ O	12 to 14	1 to 6	2 to 5	1 to 3	1 to 3	2 to 5
Additional elements	Ni, Mn, Cr	Mn, Ti, Cr, Co, Ni	Mn, Ti, Cr	Mn	Ti, Mn, Cr, Ni	Mn

^{a)} common mixed crystal series



6.5 Examples of common non-asbestos fibres

Cotton:



Wollastonite (I):

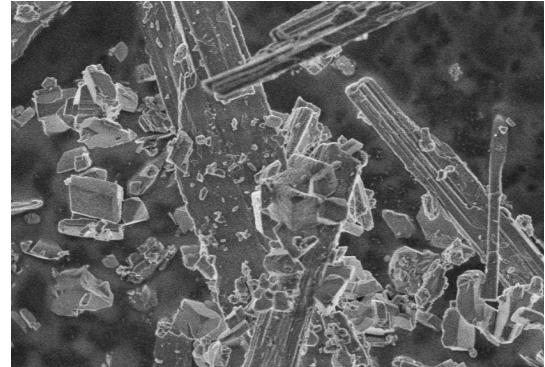

MMMF (I):



Calcium carbonate (I):

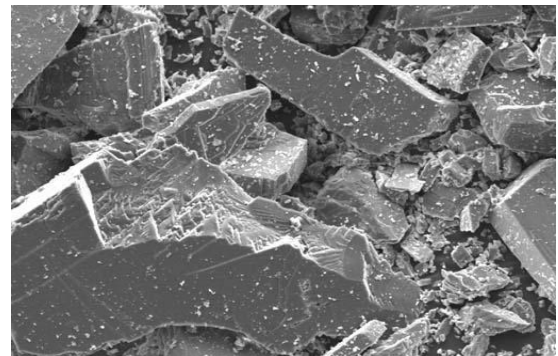

Gypsum needle (CS):

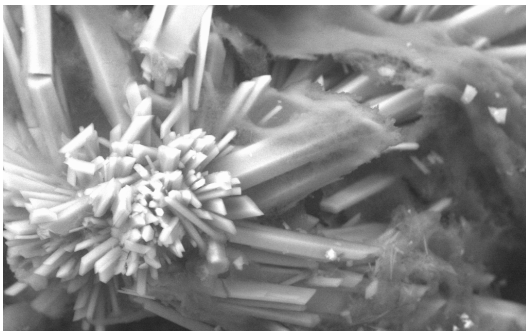

6.6 Asbestos density for quantification of fine asbestos fibres in soil as per Badollet, 1951

asbestos type	density measured g/cm³	density average g/cm³
chrysotile	2.4-2.6	2.50
amosite	3.1 - 3.25	3.18
crocidolite	3.2-3.3	3.25
actinolite	3.0 - 3.2	3.10
tremolite	2.9 - 3.2	3.05
anthophyllite	2.85 - 3.1	2.98



6.7 Fibre counting table and density calculation (fmm²)

Fibre Counting form for analysis (VDI 3492)											
Sample		Date:			Name:						
Calcium Sulphate: 1		0.00			Rejected Fibres: Ta		0				
Coordinates											
Field location (X)	Field location (Y)	Fibre Number	Image field number	Fibre length (µm)	Fibre width (µm)		Elemental Composition	Count of Fibre Type - C	Count of Fibre Type - A	Count of Fibre Type - I	Count of Fibre Type - CS
				D≥0.2µm	D<0.2µm						
		1									
		2									
		3									
		4									
		5									
		6									
		7									
		8									
		9									
		10									
		11									
		12									
		13									
		14									
		15									
		16									
		17									
		18									
		19									
		20									
Totals											
Chrysotile (C):	0		Chrysotile (density)	0.0		Number rejected					
Amphibole (A):	0		Amphibole (density)	0.0		0					
Other Inorganic fibres	0		Inorganic (density)	0.0		Number fibres without spectrum					
Calcium Sulphate	0		Calcium Sulphate	0.0							
Total number of	120		Asbestos containing structures not counted:								
Magnification (Kx)	2.07										
Screen area (mm2):	0.01		Remarks								
Total Area examined	1.2										
Fibre Concentration form (VDI 3492)											
Effective filter diameter (mm)			22.50								
Effective filter area (mm2)			397.61								
Volume of air collected (litres)			1440								
Evaluated volume of air sampled (litres)			4.346								
Totals from fibre counting											
Chrysotile (C):	0		Chrysotile (density)	0.0		Chrysotile (density)	0.000000000				
Amphibole (A):	0		Amphibole (density)	0.0		Amphibole (density)	0.000000000				
Other Inorganic fibres	0		Inorganic (density)	0.0		Inorganic (density)	0.000000000				
Calcium Sulphate	0		Calcium Sulphate	0.0		Calcium Sulphate	0.000000000				
Total number of	120										
Magnification (Kx)	2.07										
Screen area (mm2):	0.01		Remarks								
Total Area examined	1.2										
95% confidence	Sample air volume -	Number of image	Area of an image	effective diameter -	Confidence						
0.6879903834	1,440.00	120	0.01	22.50	0.00048						

6.8 SEM Asbestos Fibre Counting Test Certificate



Head Office
 7 Halifax Court, Dunston,
 Gateshead, NE11 9JT
 E: enquiries@lucionservices.com
 T: 0345 5040 303

Lucion Environmental Ltd
 Registered in England + Wales 6495874
 VAT Registration Number 208156326

SEM Asbestos Fibre Counting Test Certificate

This certificate is for the attention of

Contract Title
 Site Address
 Test material sampled by
 Sampling date
 Analyst(s)
 Analyst signature(s)
 Analysis date
 Approved signatory **Nichola Byron**
 Approved signature 
 Approval date
 Report rendered on **8/6/2022**

Sample description

Analysis requested Fibre counting of airborne respirable fibres using Scanning Electron Microscopy and chemical identification of the analysed fibres using Energy Dispersive X-ray Spectroscopy

Analysis method The analysis was carried out using our in-house documented method based upon ISO14966 and VDI3492. Our method includes initial ashing of the filters (all organic fibres are also

Results and comments

- Amphibole fibres found
- Chrysotile fibres found

Job number &	Sampled air volume	Respirable fibres	No of fields searched	Total fibre	Asbestos fibre	Detection limit based	Reported
	1440	0	120	0.0000	0.0000	0.0005	<0.0005
	1440	0	120	0.0000	0.0000	0.0005	<0.0005
	1440	0	120	0.0000	0.0000	0.0005	<0.0005
	1440	0	120	0.0000	0.0000	0.0005	<0.0005
	1440	0	120	0.0000	0.0000	0.0005	<0.0005
	1440	0	120	0.0000	0.0000	0.0005	<0.0005
	1440	0	120	0.0000	0.0000	0.0005	<0.0005
	1440	0	120	0.0000	0.0000	0.0005	<0.0005
	1440	0	120	0.0000	0.0000	0.0005	<0.0005
	1440	0	120	0.0000	0.0000	0.0005	<0.0005

Detection limit is reported as the numerical fibre concentration below which, with 95% probability, the actual concentration lies when no fibres are detected. Detection limit

Lucion bear no responsibility for sample collection or sample description related information provided by the client.

Where Lucion Environmental Ltd has not undertaken the sampling; any prior sampling activity is beyond the company's responsibility. Where Lucion Environmental Ltd has sampled the test material, this has been done in accordance with TOP02.09 and TOP02.09.03. Any opinions and interpretations expressed herein are outside the scope of UKAS accreditation.



6.9 Upper and lower limits of the Poissonian 95% confidence interval of a count (Table 2, ISO14966)

Fibre count	Lower λ_L	Upper λ_U	Fibre count	Lower λ_L	Upper λ_U	Fibre count	Lower λ_L	Upper λ_U
0	0	3,689 ^a	46	33,678	61,358	92	74,164	112,83
1	0,025	5,572	47	34,534	62,501	93	75,061	113,94
2	0,242	7,225	48	35,392	63,642	94	75,959	115,04
3	0,619	8,767	49	36,251	64,781	95	76,858	116,14
4	1,090	10,242	50	37,112	65,919	96	77,757	117,24
5	1,624	11,669	51	37,973	67,056	97	78,657	118,34
6	2,202	13,060	52	38,837	68,192	98	79,557	119,44
7	2,814	14,423	53	39,701	69,326	99	80,458	120,53
8	3,454	15,764	54	40,567	70,459	100	81,360	121,66
9	4,115	17,085	55	41,433	71,591	110	90,400	132,61
10	4,795	18,391	56	42,301	72,721	120	99,490	143,52
11	5,491	19,683	57	43,171	73,851	130	108,61	154,39
12	6,201	20,962	58	44,041	74,979	140	117,77	165,23
13	6,922	22,231	59	44,912	76,106	150	126,96	176,04
14	7,654	23,490	60	45,785	77,232	160	136,17	186,83
15	8,396	24,741	61	46,658	78,357	170	145,41	197,59
16	9,146	25,983	62	47,533	79,482	180	154,66	208,33
17	9,904	27,219	63	48,409	80,605	190	163,94	219,05
18	10,668	28,448	64	49,286	81,727	200	173,24	229,75
19	11,440	29,671	65	50,164	82,848	210	182,56	240,43
20	12,217	30,889	66	51,042	83,969	220	191,89	251,10
21	13,000	32,101	67	51,922	85,088	230	201,24	261,75
22	13,788	33,309	68	52,803	86,207	240	210,60	272,39
23	14,581	34,512	69	53,685	87,324	250	219,97	283,01
24	15,378	35,711	70	54,567	88,441	260	229,36	293,62
25	16,178	36,905	71	55,451	89,557	270	238,75	304,23
26	16,983	38,097	72	56,335	90,673	280	248,16	314,82
27	17,793	39,284	73	57,220	91,787	290	257,58	325,39
28	18,606	40,468	74	58,106	92,901	300	267,01	335,96
29	19,422	41,649	75	58,993	94,014	310	276,45	346,52
30	20,241	42,827	76	59,880	95,126	320	285,90	357,08
31	21,063	44,002	77	60,768	96,237	330	295,36	367,62
32	21,888	45,175	78	61,657	97,348	340	304,82	378,15
33	22,715	46,345	79	62,547	98,458	350	314,29	388,68
34	23,545	47,512	80	63,437	99,567	360	323,77	399,20
35	24,378	48,677	81	64,328	100,68	370	333,26	409,71
36	25,213	49,840	82	65,219	101,79	380	342,75	420,22
37	26,050	51,000	83	66,111	102,90	390	352,25	430,72
38	26,890	52,158	84	67,003	104,00	400	361,76	441,21
39	27,732	53,315	85	67,897	105,11	410	371,27	451,69
40	28,575	54,469	86	68,790	106,21	420	380,79	462,18
41	29,421	55,622	87	69,684	107,32	430	390,32	472,65
42	30,269	56,772	88	70,579	108,42	440	399,85	483,12
43	31,119	57,921	89	71,474	109,53	450	409,38	493,58
44	31,970	59,068	90	72,370	110,63	460	418,92	504,04
45	32,823	60,214	91	73,267	111,73	470	428,47	514,50

^a The one-sided upper 95 % confidence limit for zero structures is 2,99.



End of document

Appendix G - Lucion Staff Qualifications

This is to certify that

Adam Rollinson

has been awarded the

**RSPH Level 3 Award in Asbestos Air
Monitoring and Clearance Procedures**

601/8286/6

PASS

Date of Award
14 April 2023



Director of Qualifications

Faculty of
Occupational
Hygiene



Daniel Embleton

has been awarded the

Proficiency Certificate
in
P403 - Asbestos Fibre Counting (PCM) (including
Sampling Strategies)

A handwritten signature in black ink, appearing to read 'LAM', is written over a faint, larger version of the BOHS logo.



Leonard Morris
Chief Examiner

January 2019

Certificate No: 20190116-39311-11518

BOHS, 5/6 Melbaume Business Court, Millennium Way, Pride Park, Derby, DE24 8LZ, UK
BOHS Incorporated by Royal Charter No. RC000858 Registered Charity No. 1150455

Appendix E – Thames Laboratory/IOM Results

Certificate Number	J267581/IJ01
Page 1 of 5	



Reassurance Test Certificate

Site Address: Maw Green Maw Green Road Crewe CW1 5NG	Client: Provectus Group	Test Location: Soil Processing, Equipment & Landfill Areas
---	-----------------------------------	--

Test / Inspection details and comments

Internal Procedure: 4No SEM Air Tests

Description: 4No SEM Air Tests

Key

Works/Sample Location Diagram

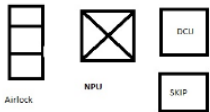

VP = Vision Panel

Disclaimers: Comments, opinions and interpretations are outside the scope of UKAS accreditation

Analyst's Name: Steve Minto	Analyst Signature: 	Issue Date: 07 September 2023
--------------------------------	------------------------	----------------------------------



Hollow Farm, Hilton Road, Fenstanton, Cambridgeshire, PE28 9LJ
Company Number: 02647438 | Registered: England & Wales

The Hazard Management and Environmental Services Laboratories Limited trading as Thames Laboratories

Certificate Number	J267581/IJ01
Page 2 of 5	



Test Type
Reassurance (Android)

	Yes/No
Is test area dry?	Yes
Is an airflow present?	Yes
Are any obvious sources of fibre present (Non Asbestos)?	No
If leak testing has enclosure been inspected?	N/A
Is area clean and dust free	No

Comments
Carrying out 4No SEM testing as agreed with Provectus



Hollow Farm, Hilton Road, Fenstanton, Cambridgeshire, PE28 9LJ
 Company Number: 02647438 | Registered: England & Wales
 The Hazard Management and Environmental Services Laboratories Limited trading as Thames Laboratories

Certificate Number	J267581/IJ01
Page 3 of 5	



Test Type
Reassurance (Android)

Analytical Details																			
Disturbance Method				NA				Duration (Mins)				N/A mins							
Microscope No		MS41		NPL Test Slide No		NPL11		Timer Barometer No				Stage Micrometer No		SM5					
Flowmeter No		FL29		Band 5 Seen		Yes		Area Size		0 m ³		Graticule Diameter		100					
Calibration Location				Temperature				N/A				Atmospheric Pressure				N/A			
Test Area				Temperature				N/A				Atmospheric Pressure				N/A			
No	Cowl No	Pump No	Start Flow (L/min)	Finish Flow (L/min)	Average Flow (L/min)	Time On	Time Off	Duration (Mins)	Volume (Litres)	Fibres	Fields	LOQ	Calculated Result f/ml	Reported Result f/ml	Location				
IJ000674	H128	JD30	15.5	15.5	15.5	09:08	13:08	240	3720	Dirty Slide					Equipment Area - Gantry Above Holding Tank				
IJ000675	H72	JD16	15.5	15.5	15.5	09:13	13:13	240	3720	Dirty Slide					Processing Area - Between Scrap Metal Skip & Picking Pod - 50 Metres From IJ-674				
IJ000676	H114	JD46	15.5	15.5	15.5	09:17	13:17	240	3720	Dirty Slide					Landfill Area - 50 Metres From IJ-675				
IJ000677	H174	JD12	15.5	15.5	15.5	09:19	13:19	240	3720	Dirty Slide					Landfill Area - 50 Metres From IJ-676				

Further Comments:

Carrying out 4No SEM testing as agreed with Provectus

0830 - Weather Condition:-

Temperature - 19.4

Wind - South Easterly / Gust 3 / Average 1

Humidity - 93



Hollow Farm, Hilton Road, Fenstanton, Cambridgeshire, PE28 9LJ
 Company Number: 02647438 | Registered: England & Wales

The Hazard Management and Environmental Services Laboratories Limited trading as Thames Laboratories

Certificate Number	J267581/IJ01
Page 4 of 5	



Rainfall 0.0 / Spitting Overnight

Reassurance Testing: This refers to testing in circumstances not covered by other forms of tests, an example being following removal of an enclosure upon completion of asbestos removal works. Generally results should be below 0.010 fibres per millilitre to be considered satisfactory. Thames Laboratories is the trading name of The Hazard Management and Environmental Services Laboratories Limited

Reported Result: The reported result will be the limit of quantification (LOQ) for the test when the calculated result is below the LOQ this will be reported within the table above in the reported result column all LOQ results will be pre fixed by a < symbol



Hollow Farm, Hilton Road, Fenstanton, Cambridgeshire, PE28 9LJ
 Company Number: 02647438 | Registered: England & Wales

The Hazard Management and Environmental Services Laboratories Limited trading as Thames Laboratories

Certificate Number	J267581/IJ01
Page 5 of 5	



Site Activity Log		
Job Number: J267581/IJ01	Site Address: Maw Green, Maw Green Road, Crewe, CW1 5NG	Client: Provectus Group

Date	Time	Activity	Staff Member
There were no diary entries.			

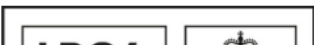

CERTIFICATE OF ANALYSIS

ANALYSIS REQUESTED BY: Thames Laboratories
Hollow Farm
9 Hilton Road
Fenstanton
PE28 9LJ

CONTRACT NO: S35800-3

DATE OF ISSUE: 18.09.23

DATE ANALYSIS REQUESTED: 12.09.23

DATE ANALYSIS COMPLETED: 15.09.23

SAMPLES: Four airborne dust samples each supplied on a gridded MCE membrane filter.

ANALYSIS REQUESTED: Fibre Counting using Scanning Electron Microscopy (SEM) with fibre identification by Energy Dispersive X-ray Spectroscopy (EDXS)

METHOD:

Each membrane filter is ashed in a low temperature plasma asher. The residue is recovered using filtered, distilled water and filtered through a 25mm, 0.4µm pore size polycarbonate filter. A portion of each polycarbonate filter is excised and mounted on a 13mm aluminium stub, coated with gold and examined by SEM. Each filter is searched systematically at 2000X magnification until an area of 1mm² has been examined or 50 whole fibres found. All respirable fibres (aspect ratio >3:1, length >5µm and diameter <3µm and including fibres in contact with particles >3µm diameter) detected are analysed by EDXS and identified as closely as possible, by comparing morphology and composition with standard reference materials. Fibre counting rules based on those of ISO14966:2019 were used.

The method used for analysis is documented in IOM instruction manual No.1 and is based on **International Standards Organisation (2019), International Standard 14966, Ambient Air: Determination of numerical concentration of inorganic fibrous particles - Scanning electron microscopy method.**

RESULTS:

Client Ref: Maw Green

Sample No.	Volume (l)	(¹) No. of Resp. Fibres Found	(¹) No. of Fields Searched	Total Fibres <i>Fibre Concⁿ (fml⁻¹)</i>	AMX Fibre <i>No. of Resp. Fibres/ Fibre Concⁿ (fml⁻¹)</i>	CMX Fibre <i>No. of Resp. Fibres/ Fibre Concⁿ (fml⁻¹)</i>	MMMF <i>No. of Resp. Fibres/ Fibre Concⁿ (fml⁻¹)</i>	NAM Fibre <i>No. of Resp. Fibres/ Fibre Concⁿ (fml⁻¹)</i>
J267581 IH674 (07/09/23)	3720	2.5	600	<0.00005*	0 / <0.00005*	0 / <0.00005*	2.5 / <0.00005*	0 / <0.00005*
J267581 IH675 (07/09/23)	3720	1	600	<0.00005*	0 / <0.00005*	0 / <0.00005*	0 / <0.00005*	1 / <0.00005*
J267581 IH676 (07/09/23)	3720	3	600	0.00005	0 / <0.00005*	0 / <0.00005*	3 / 0.00005	0 / <0.00005*
J267581 IH677 (07/09/23)	3720	2	600	<0.00005*	1 / <0.00005*	0 / <0.00005*	0 / <0.00005*	1 / <0.00005*

AMX-Amphibole Asbestos

CMX-Chrysotile Asbestos

MMMF-Machine Made Mineral Fibres

NAM-Non Asbestos Mineral

*** DETECTION LIMIT**

When no fibres of a given type are detected, the fibre concentration can be reported as less than the concentration equivalent to three fibres (the one sided upper 95% confidence limit of the Poisson distribution). Therefore, when 0, 1 or 2 fibres are detected, 2.99 is used in the calculation of fibre concentrations. It expresses the 95% confidence detection limit for airborne fibre concentrations. When a volume of 3720 litres is used the 95% confidence limit is 0.00005 fml⁻¹ for the number of fields searched.

CONTRACT NO: S35800-3
DATE OF ISSUE: 18.09.23

COMMENTS:

A single amphibole asbestos fibre was detected during the analysis of sample number J267581 IH677. No asbestos fibres were detected during the analysis of any of the other samples.

At the client's request, a greater number of screen areas than that used for our standard analysis were analysed in order to achieve the required limit of detection.

Any organic fibres present on the original samples would be destroyed during plasma ashing.

⁽¹⁾ UKAS accreditation for this work is limited to results obtained directly from the analysis. Calculated results based on sampling information provided by the client are out with the scope of this accreditation.

Any opinions and interpretations expressed herein are out with the scope of our UKAS accreditation.

IOM Consulting cannot accept responsibility for samples sent for analysis that have been incorrectly collected or despatched.



AUTHORISED BY:

S Clark
Head of Mineralogy

Appendix F – DETS Results



Becky Homer
Hydrock
4 lakeside
Festival Park
Stoke on Trent
ST1 5RY

Derwentside Environmental Testing Services Ltd
Unit 1
Rose Lane Industrial Estate
Rose Lane
Lenham Heath
Kent
ME17 2JN
t: 01622 850410

DETS Report No: 23-11454

Site Reference: Maw Green
Project / Job Ref: 28480
Order No: PO28511
Sample Receipt Date: 11/09/2023
Sample Scheduled Date: 11/09/2023
Report Issue Number: 1
Reporting Date: 19/09/2023

Authorised by:

Dave Ashworth
Technical Manager

Dates of laboratory activities for each tested analyte are available upon request.

Opinions and interpretations are outside the laboratory's scope of ISO 17025 accreditation. This certificate is issued in accordance with the accreditation requirements of the United Kingdom Accreditation Service. The results reported herein relate only to the material supplied to the laboratory. This certificate shall not be reproduced except in full, without the prior written approval of the laboratory.



DETS Ltd
Unit 1, Rose Lane Industrial Estate
Rose Lane
Lenham Heath
Maidstone
Kent ME17 2JN
Tel : 01622 850410



Soil Analysis Certificate						
DETS Report No: 23-11454	Date Sampled	04/09/23	04/09/23	04/09/23	04/09/23	04/09/23
Hydrock	Time Sampled	None Supplied	None Supplied	None Supplied	None Supplied	None Supplied
Site Reference: Maw Green	TP / BH No	SP/PS/4.9.23/-1	SP/PS/4.9.23/-2	SP/F/4.9.23/-1	SP/F/4.9.23/-2	SLAB/F/4.9.23/-1
Project / Job Ref: 28480	Additional Refs	Stockpile	Stockpile	Stockpile	Stockpile	Surface
Order No: PO28511	Depth (m)	None Supplied	None Supplied	None Supplied	None Supplied	None Supplied
Reporting Date: 19/09/2023	DETS Sample No	674180	674181	674182	674183	674184

Determinand	Unit	RL	Accreditation					
Asbestos Screen ^(S)	N/a	N/a	ISO17025	Detected	Detected	Detected	Detected	Detected
Sample Matrix ^(S)	Material Type	N/a	NONE	Chrysotile present as fibre bundles	Chrysotile present as fibre bundles	Chrysotile present as fibre bundles	Chrysotile present as fibre bundles	Chrysotile present as fibre bundles
Asbestos Type ^(S)	PLM Result	N/a	ISO17025	Chrysotile	Chrysotile	Chrysotile	Chrysotile	Chrysotile

Analytical results are expressed on a dry weight basis where samples are assisted-dried at less than 30°C. The Method Description page describes if the test is performed on the dried or as-received portion
 Subcontracted analysis (S)



DETS Ltd
Unit 1, Rose Lane Industrial Estate
Rose Lane
Lenham Heath
Maidstone
Kent ME17 2JN
Tel : 01622 850410



Soil Analysis Certificate						
DETS Report No: 23-11454	Date Sampled	04/09/23	05/09/23	05/09/23	05/09/23	05/09/23
Hydrock	Time Sampled	None Supplied	None Supplied	None Supplied	None Supplied	None Supplied
Site Reference: Maw Green	TP / BH No	SLAB/F/4.9.23/-2	SP/PS/5.9.23/-1	SP/PS/5.9.23/-2	SP/F/5.9.23/-1	SP/F/5.9.23/-2
Project / Job Ref: 28480	Additional Refs	Surface	Surface	Stockpile	Stockpile	Stockpile
Order No: PO28511	Depth (m)	None Supplied	None Supplied	None Supplied	None Supplied	None Supplied
Reporting Date: 19/09/2023	DETS Sample No	674185	674186	674187	674188	674189

Determinand	Unit	RL	Accreditation					
Asbestos Screen ^(S)	N/a	N/a	ISO17025	Detected	Detected	Detected	Detected	Detected
Sample Matrix ^(S)	Material Type	N/a	NONE	Chrysotile present as fibre bundles	Amosite present as fibre bundles	Chrysotile present as fibre bundles	Amosite present as fibre bundles	Chrysotile present as fibre bundles
Asbestos Type ^(S)	PLM Result	N/a	ISO17025	Chrysotile	Amosite	Chrysotile	Amosite	Chrysotile

Analytical results are expressed on a dry weight basis where samples are assisted-dried at less than 30°C. The Method Description page describes if the test is performed on the dried or as-received portion
 Subcontracted analysis (S)



DETS Ltd
Unit 1, Rose Lane Industrial Estate
Rose Lane
Lenham Heath
Maidstone
Kent ME17 2JN
Tel : 01622 850410



Soil Analysis Certificate						
DETS Report No: 23-11454		Date Sampled	05/09/23	05/09/23		
Hydrock		Time Sampled	None Supplied	None Supplied		
Site Reference: Maw Green		TP / BH No	SLAB/F/5.9.23/-1	SLAB/F/5.9.23/-2		
Project / Job Ref: 28480		Additional Refs	Surface	Surface		
Order No: PO28511		Depth (m)	None Supplied	None Supplied		
Reporting Date: 19/09/2023		DETS Sample No	674190	674191		

Determinand	Unit	RL	Accreditation				
Asbestos Screen ^(S)	N/a	N/a	ISO17025	Detected	Detected		
Sample Matrix ^(S)	Material Type	N/a	NONE	Chrysotile present in microscopic cement fragment	Chrysotile present as fibre bundles		
Asbestos Type ^(S)	PLM Result	N/a	ISO17025	Chrysotile	Chrysotile		

Analytical results are expressed on a dry weight basis where samples are assisted-dried at less than 30°C. The Method Description page describes if the test is performed on the dried or as-received portion
 Subcontracted analysis (S)



DETS Ltd
Unit 1, Rose Lane Industrial Estate
Rose Lane
Lenham Heath
Maidstone
Kent ME17 2JN
Tel : 01622 850410

Soil Analysis Certificate - Methodology & Miscellaneous Information	
DETS Report No: 23-11454	
Hydrock	
Site Reference: Maw Green	
Project / Job Ref: 28480	
Order No: PO28511	
Reporting Date: 19/09/2023	

Matrix	Analysed On	Determinand	Brief Method Description	Method No
Soil	D	Boron - Water Soluble	Determination of water soluble boron in soil by 2:1 hot water extract followed by ICP-OES	E012
Soil	AR	BTEX	Determination of BTEX by headspace GC-MS	E001
Soil	D	Cations	Determination of cations in soil by aqua-regia digestion followed by ICP-OES	E002
Soil	D	Chloride - Water Soluble (2:1)	Determination of chloride by extraction with water & analysed by ion chromatography	E009
Soil	AR	Chromium - Hexavalent	Determination of hexavalent chromium in soil by extraction in water then by acidification, addition of 1,5 diphenylcarbazide followed by colorimetry	E016
Soil	AR	Cyanide - Complex	Determination of complex cyanide by distillation followed by colorimetry	E015
Soil	AR	Cyanide - Free	Determination of free cyanide by distillation followed by colorimetry	E015
Soil	AR	Cyanide - Total	Determination of total cyanide by distillation followed by colorimetry	E015
Soil	D	Cyclohexane Extractable Matter (CEM)	Gravimetrically determined through extraction with cyclohexane	E011
Soil	AR	Diesel Range Organics (C10 - C24)	Determination of hexane/acetone extractable hydrocarbons by GC-FID	E004
Soil	AR	Electrical Conductivity	Determination of electrical conductivity by addition of saturated calcium sulphate followed by electrometric measurement	E022
Soil	AR	Electrical Conductivity	Determination of electrical conductivity by addition of water followed by electrometric measurement	E023
Soil	D	Elemental Sulphur	Determination of elemental sulphur by solvent extraction followed by GC-MS	E020
Soil	AR	EPH (C10 – C40)	Determination of acetone/hexane extractable hydrocarbons by GC-FID	E004
Soil	AR	EPH Product ID	Determination of acetone/hexane extractable hydrocarbons by GC-FID	E004
Soil	AR	EPH TEXAS (C6-C8, C8-C10, C10-C12, C12-C16, C16-C21, C21-C40)	Determination of acetone/hexane extractable hydrocarbons by GC-FID for C8 to C40. C6 to C8 by headspace GC-MS	E004
Soil	D	Fluoride - Water Soluble	Determination of Fluoride by extraction with water & analysed by ion chromatography	E009
Soil	D	Fraction Organic Carbon (FOC)	Determination of TOC by combustion analyser.	E027
Soil	D	Organic Matter (SOM)	Determination of TOC by combustion analyser.	E027
Soil	D	TOC (Total Organic Carbon)	Determination of TOC by combustion analyser.	E027
Soil	AR	Exchangeable Ammonium	Determination of ammonium by discrete analyser.	E029
Soil	D	FOC (Fraction Organic Carbon)	Determination of fraction of organic carbon by oxidising with potassium dichromate followed by titration with iron (II) sulphate	E010
Soil	D	Loss on Ignition @ 450oC	Determination of loss on ignition in soil by gravimetrically with the sample being ignited in a muffle furnace	E019
Soil	D	Magnesium - Water Soluble	Determination of water soluble magnesium by extraction with water followed by ICP-OES	E025
Soil	D	Metals	Determination of metals by aqua-regia digestion followed by ICP-OES	E002
Soil	AR	Mineral Oil (C10 - C40)	Determination of hexane/acetone extractable hydrocarbons by GC-FID fractionating with SPE cartridge	E004
Soil	AR	Moisture Content	Moisture content; determined gravimetrically	E003
Soil	D	Nitrate - Water Soluble (2:1)	Determination of nitrate by extraction with water & analysed by ion chromatography	E009
Soil	D	Organic Matter	Determination of organic matter by oxidising with potassium dichromate followed by titration with iron (II) sulphate	E010
Soil	AR	PAH - Speciated (EPA 16)	Determination of PAH compounds by extraction in acetone and hexane followed by GC-MS with the use of surrogate and internal standards	E005
Soil	AR	PCB - 7 Congeners	Determination of PCB by extraction with acetone and hexane followed by GC-MS	E008
Soil	D	Petroleum Ether Extract (PEE)	Gravimetrically determined through extraction with petroleum ether	E011
Soil	AR	pH	Determination of pH by addition of water followed by electrometric measurement	E007
Soil	AR	Phenols - Total (monohydric)	Determination of phenols by distillation followed by colorimetry	E021
Soil	D	Phosphate - Water Soluble (2:1)	Determination of phosphate by extraction with water & analysed by ion chromatography	E009
Soil	D	Sulphate (as SO4) - Total	Determination of total sulphate by extraction with 10% HCl followed by ICP-OES	E013
Soil	D	Sulphate (as SO4) - Water Soluble (2:1)	Determination of sulphate by extraction with water & analysed by ion chromatography	E009
Soil	D	Sulphate (as SO4) - Water Soluble (2:1)	Determination of water soluble sulphate by extraction with water followed by ICP-OES	E014
Soil	AR	Sulphide	Determination of sulphide by distillation followed by colorimetry	E018
Soil	D	Sulphur - Total	Determination of total sulphur by extraction with aqua-regia followed by ICP-OES	E024
Soil	AR	SVOC	Determination of semi-volatile organic compounds by extraction in acetone and hexane followed by GC-MS	E006
Soil	AR	Thiocyanate (as SCN)	Determination of thiocyanate by extraction in caustic soda followed by acidification followed by addition of ferric nitrate followed by colorimetry	E017
Soil	D	Toluene Extractable Matter (TEM)	Gravimetrically determined through extraction with toluene	E011
Soil	D	Total Organic Carbon (TOC)	Determination of organic matter by oxidising with potassium dichromate followed by titration with iron (II) sulphate	E010
Soil	AR	TPH CWG (ali: C5- C6, C6-C8, C8-C10, C10-C12, C12-C16, C16-C21, C21-C34, aro: C5-C7, C7-C8, C8-C10, C10-C12, C12-C16, C16-C21, C21-C35)	Determination of hexane/acetone extractable hydrocarbons by GC-FID fractionating with SPE cartridge for C8 to C35. C5 to C8 by headspace GC-MS	E004
Soil	AR	TPH LQM (ali: C5-C6, C6-C8, C8-C10, C10-C12, C12-C16, C16-C35, C35-C44, aro: C5-C7, C7-C8, C8-C10, C10-C12, C12-C16, C16-C21, C21-C35, C35-C44)	Determination of hexane/acetone extractable hydrocarbons by GC-FID fractionating with SPE cartridge for C8 to C44. C5 to C8 by headspace GC-MS	E004
Soil	AR	VOCS	Determination of volatile organic compounds by headspace GC-MS	E001
Soil	AR	VPH (C6-C8 & C8-C10)	Determination of hydrocarbons C6-C8 by headspace GC-MS & C8-C10 by GC-FID	E001

D Dried
AR As Received



DETS Ltd
Unit 1, Rose Lane Industrial Estate
Rose Lane
Lenham Heath
Maidstone
Kent ME17 2JN
Tel : 01622 850410



List of HWOL Acronyms and Operators
DETS Report No: 23-11454
Hydrock
Site Reference: Maw Green
Project / Job Ref: 28480
Order No: PO28511
Reporting Date: 19/09/2023

Acronym	Description
HS	Headspace analysis
EH	Extractable Hydrocarbons - i.e. everything extracted by the solvent
CU	Clean-up - e.g. by florisil, silica gel
1D	GC - Single coil gas chromatography
2D	GC-GC - Double coil gas chromatography
Total	Aliphatics & Aromatics
AL	Aliphatics only
AR	Aromatics only
#1	EH_2D_Total but with humics mathematically subtracted
#2	EH_2D_Total but with fatty acids mathematically subtracted
	Operator - underscore to separate acronyms (exception for +)
+	Operator to indicate cumulative eg. EH+HS_Total or EH_CU+HS_Total

Det - Acronym



Becky Homer
Hydrock
4 lakeside
Festival Park
Stoke on Trent
ST1 5RY

Derwentside Environmental Testing Services Ltd
Unit 1
Rose Lane Industrial Estate
Rose Lane
Lenham Heath
Kent
ME17 2JN
t: 01622 850410

DETS Report No: 23-11455

Site Reference: Maw Green
Project / Job Ref: 28480
Order No: PO28511
Sample Receipt Date: 11/09/2023
Sample Scheduled Date: 11/09/2023
Report Issue Number: 1
Reporting Date: 06/10/2023

Authorised by:

A handwritten signature in black ink, appearing to read 'D Ashworth', is written over a light blue horizontal line.

Dave Ashworth
Technical Manager

Dates of laboratory activities for each tested analyte are available upon request.

Opinions and interpretations are outside the laboratory's scope of ISO 17025 accreditation. This certificate is issued in accordance with the accreditation requirements of the United Kingdom Accreditation Service. The results reported herein relate only to the material supplied to the laboratory. This certificate shall not be reproduced except in full, without the prior written approval of the laboratory.



DETS Ltd
Unit 1, Rose Lane Industrial Estate
Rose Lane
Lenham Heath
Maidstone
Kent ME17 2JN
Tel : 01622 850410

Soil Analysis Certificate						
DETS Report No: 23-11455	Date Sampled	04/09/23	04/09/23	04/09/23	04/09/23	04/09/23
Hydrock	Time Sampled	None Supplied	None Supplied	None Supplied	None Supplied	None Supplied
Site Reference: Maw Green	TP / BH No	SP/PS/4.9.23/-1	SP/PS/4.9.23/-2	SP/F/4.9.23/-1	SP/F/4.9.23/-2	SLAB/F/4.9.23/-1
Project / Job Ref: 28480	Additional Refs	Stockpile	Stockpile	Stockpile	Stockpile	Surface
Order No: PO28511	Depth (m)	None Supplied	None Supplied	None Supplied	None Supplied	None Supplied
Reporting Date: 06/10/2023	DETS Sample No	674192	674193	674194	674195	674196

Determinand	Unit	RL	Accreditation					
Asbestos - Respirable Dust ^(S)	f/mg	0.001	NONE	19200.000	28100.000	20400.000	17900.000	38300.000

Analytical results are expressed on a dry weight basis where samples are assisted-dried at less than 30°C. The Method Description page describes if the test is performed on the dried or as-received portion
 Subcontracted analysis (S)



DETS Ltd
Unit 1, Rose Lane Industrial Estate
Rose Lane
Lenham Heath
Maidstone
Kent ME17 2JN
Tel : 01622 850410

Soil Analysis Certificate						
DETS Report No: 23-11455	Date Sampled	04/09/23	05/09/23	05/09/23	05/09/23	05/09/23
Hydrock	Time Sampled	None Supplied	None Supplied	None Supplied	None Supplied	None Supplied
Site Reference: Maw Green	TP / BH No	SLAB/F/4.9.23/-2	SP/PS/5.9.23/-1	SP/PS/5.9.23/-2	SP/F/5.9.23/-1	SP/F/5.9.23/-2
Project / Job Ref: 28480	Additional Refs	Surface	Stockpile	Stockpile	Stockpile	Stockpile
Order No: PO28511	Depth (m)	None Supplied	None Supplied	None Supplied	None Supplied	None Supplied
Reporting Date: 06/10/2023	DETS Sample No	674197	674198	674199	674200	674201

Determinand	Unit	RL	Accreditation					
Asbestos - Respirable Dust ^(S)	f/mg	0.001	NONE	21700.000	12800.000	24300.000	26800.000	29400.000

Analytical results are expressed on a dry weight basis where samples are assisted-dried at less than 30°C. The Method Description page describes if the test is performed on the dried or as-received portion
 Subcontracted analysis (S)



DETS Ltd
Unit 1, Rose Lane Industrial Estate
Rose Lane
Lenham Heath
Maidstone
Kent ME17 2JN
Tel : 01622 850410

Soil Analysis Certificate						
DETS Report No: 23-11455	Date Sampled	05/09/23	05/09/23			
Hydrock	Time Sampled	None Supplied	None Supplied			
Site Reference: Maw Green	TP / BH No	SLAB/F/5.9.23/-1	SLAB/F/5.9.23/-2			
Project / Job Ref: 28480	Additional Refs	Surface	Surface			
Order No: PO28511	Depth (m)	None Supplied	None Supplied			
Reporting Date: 06/10/2023	DETS Sample No	674202	674203			

Determinand	Unit	RL	Accreditation			
Asbestos - Respirable Dust ^(S)	f/mg	0.001	NONE	29400.000	12800.000	

Analytical results are expressed on a dry weight basis where samples are assisted-dried at less than 30°C. The Method Description page describes if the test is performed on the dried or as-received portion
 Subcontracted analysis (S)



DETS Ltd
Unit 1, Rose Lane Industrial Estate
Rose Lane
Lenham Heath
Maidstone
Kent ME17 2JN
Tel : 01622 850410

Soil Analysis Certificate - Methodology & Miscellaneous Information	
DETS Report No: 23-11455	
Hydrock	
Site Reference: Maw Green	
Project / Job Ref: 28480	
Order No: PO28511	
Reporting Date: 06/10/2023	

Matrix	Analysed On	Determinand	Brief Method Description	Method No
Soil	D	Boron - Water Soluble	Determination of water soluble boron in soil by 2:1 hot water extract followed by ICP-OES	E012
Soil	AR	BTEX	Determination of BTEX by headspace GC-MS	E001
Soil	D	Cations	Determination of cations in soil by aqua-regia digestion followed by ICP-OES	E002
Soil	D	Chloride - Water Soluble (2:1)	Determination of chloride by extraction with water & analysed by ion chromatography	E009
Soil	AR	Chromium - Hexavalent	Determination of hexavalent chromium in soil by extraction in water then by acidification, addition of 1,5 diphenylcarbazide followed by colorimetry	E016
Soil	AR	Cyanide - Complex	Determination of complex cyanide by distillation followed by colorimetry	E015
Soil	AR	Cyanide - Free	Determination of free cyanide by distillation followed by colorimetry	E015
Soil	AR	Cyanide - Total	Determination of total cyanide by distillation followed by colorimetry	E015
Soil	D	Cyclohexane Extractable Matter (CEM)	Gravimetrically determined through extraction with cyclohexane	E011
Soil	AR	Diesel Range Organics (C10 - C24)	Determination of hexane/acetone extractable hydrocarbons by GC-FID	E004
Soil	AR	Electrical Conductivity	Determination of electrical conductivity by addition of saturated calcium sulphate followed by electrometric measurement	E022
Soil	AR	Electrical Conductivity	Determination of electrical conductivity by addition of water followed by electrometric measurement	E023
Soil	D	Elemental Sulphur	Determination of elemental sulphur by solvent extraction followed by GC-MS	E020
Soil	AR	EPH (C10 – C40)	Determination of acetone/hexane extractable hydrocarbons by GC-FID	E004
Soil	AR	EPH Product ID	Determination of acetone/hexane extractable hydrocarbons by GC-FID	E004
Soil	AR	EPH TEXAS (C6-C8, C8-C10, C10-C12, C12-C16, C16-C21, C21-C40)	Determination of acetone/hexane extractable hydrocarbons by GC-FID for C8 to C40. C6 to C8 by headspace GC-MS	E004
Soil	D	Fluoride - Water Soluble	Determination of Fluoride by extraction with water & analysed by ion chromatography	E009
Soil	D	Fraction Organic Carbon (FOC)	Determination of TOC by combustion analyser.	E027
Soil	D	Organic Matter (SOM)	Determination of TOC by combustion analyser.	E027
Soil	D	TOC (Total Organic Carbon)	Determination of TOC by combustion analyser.	E027
Soil	AR	Exchangeable Ammonium	Determination of ammonium by discrete analyser.	E029
Soil	D	FOC (Fraction Organic Carbon)	Determination of fraction of organic carbon by oxidising with potassium dichromate followed by titration with iron (II) sulphate	E010
Soil	D	Loss on Ignition @ 450oC	Determination of loss on ignition in soil by gravimetrically with the sample being ignited in a muffle furnace	E019
Soil	D	Magnesium - Water Soluble	Determination of water soluble magnesium by extraction with water followed by ICP-OES	E025
Soil	D	Metals	Determination of metals by aqua-regia digestion followed by ICP-OES	E002
Soil	AR	Mineral Oil (C10 - C40)	Determination of hexane/acetone extractable hydrocarbons by GC-FID fractionating with SPE cartridge	E004
Soil	AR	Moisture Content	Moisture content; determined gravimetrically	E003
Soil	D	Nitrate - Water Soluble (2:1)	Determination of nitrate by extraction with water & analysed by ion chromatography	E009
Soil	D	Organic Matter	Determination of organic matter by oxidising with potassium dichromate followed by titration with iron (II) sulphate	E010
Soil	AR	PAH - Speciated (EPA 16)	Determination of PAH compounds by extraction in acetone and hexane followed by GC-MS with the use of surrogate and internal standards	E005
Soil	AR	PCB - 7 Congeners	Determination of PCB by extraction with acetone and hexane followed by GC-MS	E008
Soil	D	Petroleum Ether Extract (PEE)	Gravimetrically determined through extraction with petroleum ether	E011
Soil	AR	pH	Determination of pH by addition of water followed by electrometric measurement	E007
Soil	AR	Phenols - Total (monohydric)	Determination of phenols by distillation followed by colorimetry	E021
Soil	D	Phosphate - Water Soluble (2:1)	Determination of phosphate by extraction with water & analysed by ion chromatography	E009
Soil	D	Sulphate (as SO4) - Total	Determination of total sulphate by extraction with 10% HCl followed by ICP-OES	E013
Soil	D	Sulphate (as SO4) - Water Soluble (2:1)	Determination of sulphate by extraction with water & analysed by ion chromatography	E009
Soil	D	Sulphate (as SO4) - Water Soluble (2:1)	Determination of water soluble sulphate by extraction with water followed by ICP-OES	E014
Soil	AR	Sulphide	Determination of sulphide by distillation followed by colorimetry	E018
Soil	D	Sulphur - Total	Determination of total sulphur by extraction with aqua-regia followed by ICP-OES	E024
Soil	AR	SVOC	Determination of semi-volatile organic compounds by extraction in acetone and hexane followed by GC-MS	E006
Soil	AR	Thiocyanate (as SCN)	Determination of thiocyanate by extraction in caustic soda followed by acidification followed by addition of ferric nitrate followed by colorimetry	E017
Soil	D	Toluene Extractable Matter (TEM)	Gravimetrically determined through extraction with toluene	E011
Soil	D	Total Organic Carbon (TOC)	Determination of organic matter by oxidising with potassium dichromate followed by titration with iron (II) sulphate	E010
Soil	AR	TPH CWG (ali: C5- C6, C6-C8, C8-C10, C10-C12, C12-C16, C16-C21, C21-C34, aro: C5-C7, C7-C8, C8-C10, C10-C12, C12-C16, C16-C21, C21-C35)	Determination of hexane/acetone extractable hydrocarbons by GC-FID fractionating with SPE cartridge for C8 to C35. C5 to C8 by headspace GC-MS	E004
Soil	AR	TPH LQM (ali: C5-C6, C6-C8, C8-C10, C10-C12, C12-C16, C16-C35, C35-C44, aro: C5-C7, C7-C8, C8-C10, C10-C12, C12-C16, C16-C21, C21-C35, C35-C44)	Determination of hexane/acetone extractable hydrocarbons by GC-FID fractionating with SPE cartridge for C8 to C44. C5 to C8 by headspace GC-MS	E004
Soil	AR	VOCS	Determination of volatile organic compounds by headspace GC-MS	E001
Soil	AR	VPH (C6-C8 & C8-C10)	Determination of hydrocarbons C6-C8 by headspace GC-MS & C8-C10 by GC-FID	E001

D Dried
AR As Received



DETS Ltd
Unit 1, Rose Lane Industrial Estate
Rose Lane
Lenham Heath
Maidstone
Kent ME17 2JN
Tel : 01622 850410

List of HWOL Acronyms and Operators
DETS Report No: 23-11455
Hydrock
Site Reference: Maw Green
Project / Job Ref: 28480
Order No: PO28511
Reporting Date: 06/10/2023

Acronym	Description
HS	Headspace analysis
EH	Extractable Hydrocarbons - i.e. everything extracted by the solvent
CU	Clean-up - e.g. by florisil, silica gel
1D	GC - Single coil gas chromatography
2D	GC-GC - Double coil gas chromatography
Total	Aliphatics & Aromatics
AL	Aliphatics only
AR	Aromatics only
#1	EH_2D_Total but with humics mathematically subtracted
#2	EH_2D_Total but with fatty acids mathematically subtracted
	Operator - underscore to separate acronyms (exception for +)
+	Operator to indicate cumulative eg. EH+HS_Total or EH_CU+HS_Total

Det - Acronym



Becky Homer
Hydrock
4 lakeside
Festival Park
Stoke on Trent
ST1 5RY

Derwentside Environmental Testing Services Ltd
Unit 1
Rose Lane Industrial Estate
Rose Lane
Lenham Heath
Kent
ME17 2JN
t: 01622 850410

DETS Report No: 23-11456

Site Reference: Maw Green
Project / Job Ref: 28480
Order No: PO28511
Sample Receipt Date: 11/09/2023
Sample Scheduled Date: 11/09/2023
Report Issue Number: 1
Reporting Date: 19/09/2023

Authorised by:

Dave Ashworth
Technical Manager

Dates of laboratory activities for each tested analyte are available upon request.

Opinions and interpretations are outside the laboratory's scope of ISO 17025 accreditation. This certificate is issued in accordance with the accreditation requirements of the United Kingdom Accreditation Service. The results reported herein relate only to the material supplied to the laboratory. This certificate shall not be reproduced except in full, without the prior written approval of the laboratory.



DETS Ltd
Unit 1, Rose Lane Industrial Estate
Rose Lane
Lenham Heath
Maidstone
Kent ME17 2JN
Tel : 01622 850410



Soil Analysis Certificate						
DETS Report No: 23-11456	Date Sampled	06/09/23	06/09/23	06/09/23	06/09/23	06/09/23
Hydrock	Time Sampled	None Supplied	None Supplied	None Supplied	None Supplied	None Supplied
Site Reference: Maw Green	TP / BH No	SP/PS/6.9.23/-1	SP/PS/6.9.23/-2	SP/F/6.9.23/-1	SP/F/6.9.23/-2	SLAB/F/6.9.23/-1
Project / Job Ref: 28480	Additional Refs	Stockpile	Stockpile	Stockpile	Stockpile	Surface
Order No: PO28511	Depth (m)	None Supplied	None Supplied	None Supplied	None Supplied	None Supplied
Reporting Date: 19/09/2023	DETS Sample No	674204	674205	674206	674207	674208

Determinand	Unit	RL	Accreditation					
Asbestos Screen ^(S)	N/a	N/a	ISO17025	Detected	Not Detected	Not Detected	Detected	Not Detected
Sample Matrix ^(S)	Material Type	N/a	NONE	Bundle of Chrysotile fibres			Bundle of Chrysotile fibres	
Asbestos Type ^(S)	PLM Result	N/a	ISO17025	Chrysotile			Chrysotile	

Analytical results are expressed on a dry weight basis where samples are assisted-dried at less than 30°C. The Method Description page describes if the test is performed on the dried or as-received portion
 Subcontracted analysis (S)



DETS Ltd
Unit 1, Rose Lane Industrial Estate
Rose Lane
Lenham Heath
Maidstone
Kent ME17 2JN
Tel : 01622 850410



Soil Analysis Certificate						
DETS Report No: 23-11456	Date Sampled	06/09/23	07/09/23	07/09/23	07/09/23	07/09/23
Hydrock	Time Sampled	None Supplied	None Supplied	None Supplied	None Supplied	None Supplied
Site Reference: Maw Green	TP / BH No	SLAB/F/6.9.23/-2	SP/PS/7.9.23/-1	SP/PS/7.9.23/-2	SP/F/7.9.23/-1	SP/F/7.9.23/-2
Project / Job Ref: 28480	Additional Refs	Surface	Stockpile	Stockpile	Stockpile	Stockpile
Order No: PO28511	Depth (m)	None Supplied	None Supplied	None Supplied	None Supplied	None Supplied
Reporting Date: 19/09/2023	DETS Sample No	674209	674210	674211	674212	674213

Determinand	Unit	RL	Accreditation					
Asbestos Screen ^(S)	N/a	N/a	ISO17025	Detected	Not Detected	Not Detected	Detected	Detected
Sample Matrix ^(S)	Material Type	N/a	NONE	Bundles of Chrysotile fibres			Bundle of Chrysotile fibres	Bundles of Chrysotile fibres
Asbestos Type ^(S)	PLM Result	N/a	ISO17025	Chrysotile			Chrysotile	Chrysotile

Analytical results are expressed on a dry weight basis where samples are assisted-dried at less than 30°C. The Method Description page describes if the test is performed on the dried or as-received portion
 Subcontracted analysis (S)



DETS Ltd
Unit 1, Rose Lane Industrial Estate
Rose Lane
Lenham Heath
Maidstone
Kent ME17 2JN
Tel : 01622 850410



Soil Analysis Certificate						
DETS Report No: 23-11456		Date Sampled	07/09/23	07/09/23		
Hydrock		Time Sampled	None Supplied	None Supplied		
Site Reference: Maw Green		TP / BH No	SLAB/F/7.9.23/-1	SLAB/F/7.9.23/-2		
Project / Job Ref: 28480		Additional Refs	Surface	Surface		
Order No: PO28511		Depth (m)	None Supplied	None Supplied		
Reporting Date: 19/09/2023		DETS Sample No	674214	674215		

Determinand	Unit	RL	Accreditation				
Asbestos Screen ^(S)	N/a	N/a	ISO17025	Detected	Detected		
Sample Matrix ^(S)	Material Type	N/a	NONE	Chrysotile present in microscopic cement debris	Chrysotile present in microscopic cement debris		
Asbestos Type ^(S)	PLM Result	N/a	ISO17025	Chrysotile	Chrysotile		

Analytical results are expressed on a dry weight basis where samples are assisted-dried at less than 30°C. The Method Description page describes if the test is performed on the dried or as-received portion
 Subcontracted analysis (S)



DETS Ltd
Unit 1, Rose Lane Industrial Estate
Rose Lane
Lenham Heath
Maidstone
Kent ME17 2JN
Tel : 01622 850410

Soil Analysis Certificate - Methodology & Miscellaneous Information	
DETS Report No: 23-11456	
Hydrock	
Site Reference: Maw Green	
Project / Job Ref: 28480	
Order No: PO28511	
Reporting Date: 19/09/2023	

Matrix	Analysed On	Determinand	Brief Method Description	Method No
Soil	D	Boron - Water Soluble	Determination of water soluble boron in soil by 2:1 hot water extract followed by ICP-OES	E012
Soil	AR	BTEX	Determination of BTEX by headspace GC-MS	E001
Soil	D	Cations	Determination of cations in soil by aqua-regia digestion followed by ICP-OES	E002
Soil	D	Chloride - Water Soluble (2:1)	Determination of chloride by extraction with water & analysed by ion chromatography	E009
Soil	AR	Chromium - Hexavalent	Determination of hexavalent chromium in soil by extraction in water then by acidification, addition of 1,5 diphenylcarbazide followed by colorimetry	E016
Soil	AR	Cyanide - Complex	Determination of complex cyanide by distillation followed by colorimetry	E015
Soil	AR	Cyanide - Free	Determination of free cyanide by distillation followed by colorimetry	E015
Soil	AR	Cyanide - Total	Determination of total cyanide by distillation followed by colorimetry	E015
Soil	D	Cyclohexane Extractable Matter (CEM)	Gravimetrically determined through extraction with cyclohexane	E011
Soil	AR	Diesel Range Organics (C10 - C24)	Determination of hexane/acetone extractable hydrocarbons by GC-FID	E004
Soil	AR	Electrical Conductivity	Determination of electrical conductivity by addition of saturated calcium sulphate followed by electrometric measurement	E022
Soil	AR	Electrical Conductivity	Determination of electrical conductivity by addition of water followed by electrometric measurement	E023
Soil	D	Elemental Sulphur	Determination of elemental sulphur by solvent extraction followed by GC-MS	E020
Soil	AR	EPH (C10 – C40)	Determination of acetone/hexane extractable hydrocarbons by GC-FID	E004
Soil	AR	EPH Product ID	Determination of acetone/hexane extractable hydrocarbons by GC-FID	E004
Soil	AR	EPH TEXAS (C6-C8, C8-C10, C10-C12, C12-C16, C16-C21, C21-C40)	Determination of acetone/hexane extractable hydrocarbons by GC-FID for C8 to C40. C6 to C8 by headspace GC-MS	E004
Soil	D	Fluoride - Water Soluble	Determination of Fluoride by extraction with water & analysed by ion chromatography	E009
Soil	D	Fraction Organic Carbon (FOC)	Determination of TOC by combustion analyser.	E027
Soil	D	Organic Matter (SOM)	Determination of TOC by combustion analyser.	E027
Soil	D	TOC (Total Organic Carbon)	Determination of TOC by combustion analyser.	E027
Soil	AR	Exchangeable Ammonium	Determination of ammonium by discrete analyser.	E029
Soil	D	FOC (Fraction Organic Carbon)	Determination of fraction of organic carbon by oxidising with potassium dichromate followed by titration with iron (II) sulphate	E010
Soil	D	Loss on Ignition @ 450oC	Determination of loss on ignition in soil by gravimetrically with the sample being ignited in a muffle furnace	E019
Soil	D	Magnesium - Water Soluble	Determination of water soluble magnesium by extraction with water followed by ICP-OES	E025
Soil	D	Metals	Determination of metals by aqua-regia digestion followed by ICP-OES	E002
Soil	AR	Mineral Oil (C10 - C40)	Determination of hexane/acetone extractable hydrocarbons by GC-FID fractionating with SPE cartridge	E004
Soil	AR	Moisture Content	Moisture content; determined gravimetrically	E003
Soil	D	Nitrate - Water Soluble (2:1)	Determination of nitrate by extraction with water & analysed by ion chromatography	E009
Soil	D	Organic Matter	Determination of organic matter by oxidising with potassium dichromate followed by titration with iron (II) sulphate	E010
Soil	AR	PAH - Speciated (EPA 16)	Determination of PAH compounds by extraction in acetone and hexane followed by GC-MS with the use of surrogate and internal standards	E005
Soil	AR	PCB - 7 Congeners	Determination of PCB by extraction with acetone and hexane followed by GC-MS	E008
Soil	D	Petroleum Ether Extract (PEE)	Gravimetrically determined through extraction with petroleum ether	E011
Soil	AR	pH	Determination of pH by addition of water followed by electrometric measurement	E007
Soil	AR	Phenols - Total (monohydric)	Determination of phenols by distillation followed by colorimetry	E021
Soil	D	Phosphate - Water Soluble (2:1)	Determination of phosphate by extraction with water & analysed by ion chromatography	E009
Soil	D	Sulphate (as SO4) - Total	Determination of total sulphate by extraction with 10% HCl followed by ICP-OES	E013
Soil	D	Sulphate (as SO4) - Water Soluble (2:1)	Determination of sulphate by extraction with water & analysed by ion chromatography	E009
Soil	D	Sulphate (as SO4) - Water Soluble (2:1)	Determination of water soluble sulphate by extraction with water followed by ICP-OES	E014
Soil	AR	Sulphide	Determination of sulphide by distillation followed by colorimetry	E018
Soil	D	Sulphur - Total	Determination of total sulphur by extraction with aqua-regia followed by ICP-OES	E024
Soil	AR	SVOC	Determination of semi-volatile organic compounds by extraction in acetone and hexane followed by GC-MS	E006
Soil	AR	Thiocyanate (as SCN)	Determination of thiocyanate by extraction in caustic soda followed by acidification followed by addition of ferric nitrate followed by colorimetry	E017
Soil	D	Toluene Extractable Matter (TEM)	Gravimetrically determined through extraction with toluene	E011
Soil	D	Total Organic Carbon (TOC)	Determination of organic matter by oxidising with potassium dichromate followed by titration with iron (II) sulphate	E010
Soil	AR	TPH CWG (ali: C5- C6, C6-C8, C8-C10, C10-C12, C12-C16, C16-C21, C21-C34, aro: C5-C7, C7-C8, C8-C10, C10-C12, C12-C16, C16-C21, C21-C35)	Determination of hexane/acetone extractable hydrocarbons by GC-FID fractionating with SPE cartridge for C8 to C35. C5 to C8 by headspace GC-MS	E004
Soil	AR	TPH LQM (ali: C5-C6, C6-C8, C8-C10, C10-C12, C12-C16, C16-C35, C35-C44, aro: C5-C7, C7-C8, C8-C10, C10-C12, C12-C16, C16-C21, C21-C35, C35-C44)	Determination of hexane/acetone extractable hydrocarbons by GC-FID fractionating with SPE cartridge for C8 to C44. C5 to C8 by headspace GC-MS	E004
Soil	AR	VOCS	Determination of volatile organic compounds by headspace GC-MS	E001
Soil	AR	VPH (C6-C8 & C8-C10)	Determination of hydrocarbons C6-C8 by headspace GC-MS & C8-C10 by GC-FID	E001

D Dried
AR As Received



DETS Ltd
Unit 1, Rose Lane Industrial Estate
Rose Lane
Lenham Heath
Maidstone
Kent ME17 2JN
Tel : 01622 850410



List of HWOL Acronyms and Operators
DETS Report No: 23-11456
Hydrock
Site Reference: Maw Green
Project / Job Ref: 28480
Order No: PO28511
Reporting Date: 19/09/2023

Acronym	Description
HS	Headspace analysis
EH	Extractable Hydrocarbons - i.e. everything extracted by the solvent
CU	Clean-up - e.g. by florisil, silica gel
1D	GC - Single coil gas chromatography
2D	GC-GC - Double coil gas chromatography
Total	Aliphatics & Aromatics
AL	Aliphatics only
AR	Aromatics only
#1	EH_2D_Total but with humics mathematically subtracted
#2	EH_2D_Total but with fatty acids mathematically subtracted
	Operator - underscore to separate acronyms (exception for +)
+	Operator to indicate cumulative eg. EH+HS_Total or EH_CU+HS_Total

Det - Acronym



Becky Homer
Hydrock
4 lakeside
Festival Park
Stoke on Trent
ST1 5RY

Derwentside Environmental Testing Services Ltd
Unit 1
Rose Lane Industrial Estate
Rose Lane
Lenham Heath
Kent
ME17 2JN
t: 01622 850410

DETS Report No: 23-11457

Site Reference: Maw Green
Project / Job Ref: 28480
Order No: PO28511
Sample Receipt Date: 11/09/2023
Sample Scheduled Date: 11/09/2023
Report Issue Number: 1
Reporting Date: 11/10/2023

Authorised by:

Ela Mysia
Quality Manager

Dates of laboratory activities for each tested analyte are available upon request.

Opinions and interpretations are outside the laboratory's scope of ISO 17025 accreditation. This certificate is issued in accordance with the accreditation requirements of the United Kingdom Accreditation Service. The results reported herein relate only to the material supplied to the laboratory. This certificate shall not be reproduced except in full, without the prior written approval of the laboratory.



DETS Ltd
Unit 1, Rose Lane Industrial Estate
Rose Lane
Lenham Heath
Maidstone
Kent ME17 2JN
Tel : 01622 850410

Soil Analysis Certificate					
DETS Report No: 23-11457	Date Sampled	06/09/23	06/09/23	06/09/23	06/09/23
Hydrock	Time Sampled	None Supplied	None Supplied	None Supplied	None Supplied
Site Reference: Maw Green	TP / BH No	SP/PS/6.9.23/-1	SP/PS/6.9.23/-2	SP/F/6.9.23/-1	SP/F/6.9.23/-2
Project / Job Ref: 28480	Additional Refs	Surface	Surface	Surface	Surface
Order No: PO28511	Depth (m)	None Supplied	None Supplied	None Supplied	None Supplied
Reporting Date: 11/10/2023	DETS Sample No	674216	674217	674218	674219

Determinand	Unit	RL	Accreditation					
Asbestos - Respirable Dust ^(S)	f/mg	0.001	NONE	23000.000	25500.000	5110.000	16600.000	21700.000

Analytical results are expressed on a dry weight basis where samples are assisted-dried at less than 30°C. The Method Description page describes if the test is performed on the dried or as-received portion
 Subcontracted analysis (S)



DETS Ltd
Unit 1, Rose Lane Industrial Estate
Rose Lane
Lenham Heath
Maidstone
Kent ME17 2JN
Tel : 01622 850410

Soil Analysis Certificate					
DETS Report No: 23-11457	Date Sampled	06/09/23	06/09/23	06/09/23	06/09/23
Hydrock	Time Sampled	None Supplied	None Supplied	None Supplied	None Supplied
Site Reference: Maw Green	TP / BH No	SLAB/F/6.9.23/-2	SP/PS/7.9.23/-1	SP/PS/7.9.23/-2	SP/F/7.9.23/-1
Project / Job Ref: 28480	Additional Refs	Surface	Surface	Surface	Surface
Order No: PO28511	Depth (m)	None Supplied	None Supplied	None Supplied	None Supplied
Reporting Date: 11/10/2023	DETS Sample No	674221	674222	674223	674224

Determinand	Unit	RL	Accreditation					
Asbestos - Respirable Dust ^(S)	f/mg	0.001	NONE	12800.000	12800.000	7660.000	5110.000	6390.000

Analytical results are expressed on a dry weight basis where samples are assisted-dried at less than 30°C. The Method Description page describes if the test is performed on the dried or as-received portion
 Subcontracted analysis (S)



DETS Ltd
Unit 1, Rose Lane Industrial Estate
Rose Lane
Lenham Heath
Maidstone
Kent ME17 2JN
Tel : 01622 850410

Soil Analysis Certificate					
DETS Report No: 23-11457	Date Sampled	06/09/23	06/09/23		
Hydrock	Time Sampled	None Supplied	None Supplied		
Site Reference: Maw Green	TP / BH No	SLAB/F/7.9.23/-1	SLAB/F/7.9.23/-2		
Project / Job Ref: 28480	Additional Refs	Surface	Surface		
Order No: PO28511	Depth (m)	None Supplied	None Supplied		
Reporting Date: 11/10/2023	DETS Sample No	674226	674227		

Determinand	Unit	RL	Accreditation		
Asbestos - Respirable Dust ^(S)	f/mg	0.001	NONE	12800.000	35800.000

Analytical results are expressed on a dry weight basis where samples are assisted-dried at less than 30°C. The Method Description page describes if the test is performed on the dried or as-received portion
 Subcontracted analysis (S)



DETS Ltd
Unit 1, Rose Lane Industrial Estate
Rose Lane
Lenham Heath
Maidstone
Kent ME17 2JN
Tel : 01622 850410

Soil Analysis Certificate - Methodology & Miscellaneous Information

DETS Report No: 23-11457

Hydrock

Site Reference: Maw Green

Project / Job Ref: 28480

Order No: PO28511

Reporting Date: 11/10/2023

Matrix	Analysed On	Determinand	Brief Method Description	Method No
Soil	D	Boron - Water Soluble	Determination of water soluble boron in soil by 2:1 hot water extract followed by ICP-OES	E012
Soil	AR	BTEX	Determination of BTEX by headspace GC-MS	E001
Soil	D	Cations	Determination of cations in soil by aqua-regia digestion followed by ICP-OES	E002
Soil	D	Chloride - Water Soluble (2:1)	Determination of chloride by extraction with water & analysed by ion chromatography	E009
Soil	AR	Chromium - Hexavalent	Determination of hexavalent chromium in soil by extraction in water then by acidification, addition of 1,5 diphénylcarbazide followed by colorimetry	E016
Soil	AR	Cyanide - Complex	Determination of complex cyanide by distillation followed by colorimetry	E015
Soil	AR	Cyanide - Free	Determination of free cyanide by distillation followed by colorimetry	E015
Soil	AR	Cyanide - Total	Determination of total cyanide by distillation followed by colorimetry	E015
Soil	D	Cyclohexane Extractable Matter (CEM)	Gravimetrically determined through extraction with cyclohexane	E011
Soil	AR	Diesel Range Organics (C10 - C24)	Determination of hexane/acetone extractable hydrocarbons by GC-FID	E004
Soil	AR	Electrical Conductivity	Determination of electrical conductivity by addition of saturated calcium sulphate followed by electrometric measurement	E022
Soil	AR	Electrical Conductivity	Determination of electrical conductivity by addition of water followed by electrometric measurement	E023
Soil	D	Elemental Sulphur	Determination of elemental sulphur by solvent extraction followed by GC-MS	E020
Soil	AR	EPH (C10 - C40)	Determination of acetone/hexane extractable hydrocarbons by GC-FID	E004
Soil	AR	EPH Product ID	Determination of acetone/hexane extractable hydrocarbons by GC-FID	E004
Soil	AR	EPH TEXAS (C6-C8, C8-C10, C10-C12, C12-C16, C16-C21, C21-C40)	Determination of acetone/hexane extractable hydrocarbons by GC-FID for C8 to C40. C6 to C8 by headspace GC-MS	E004
Soil	D	Fluoride - Water Soluble	Determination of Fluoride by extraction with water & analysed by ion chromatography	E009
Soil	D	Fraction Organic Carbon (FOC)	Determination of TOC by combustion analyser.	E027
Soil	D	Organic Matter (SOM)	Determination of TOC by combustion analyser.	E027
Soil	D	TOC (Total Organic Carbon)	Determination of TOC by combustion analyser.	E027
Soil	AR	Exchangeable Ammonium	Determination of ammonium by discrete analyser.	E029
Soil	D	FOC (Fraction Organic Carbon)	Determination of fraction of organic carbon by oxidising with potassium dichromate followed by titration with iron (II) sulphate	E010
Soil	D	Loss on Ignition @ 450oC	Determination of loss on ignition in soil by gravimetrically with the sample being ignited in a muffle furnace	E019
Soil	D	Magnesium - Water Soluble	Determination of water soluble magnesium by extraction with water followed by ICP-OES	E025
Soil	D	Metals	Determination of metals by aqua-regia digestion followed by ICP-OES	E002
Soil	AR	Mineral Oil (C10 - C40)	Determination of hexane/acetone extractable hydrocarbons by GC-FID fractionating with SPE cartridge	E004
Soil	AR	Moisture Content	Moisture content; determined gravimetrically	E003
Soil	D	Nitrate - Water Soluble (2:1)	Determination of nitrate by extraction with water & analysed by ion chromatography	E009
Soil	D	Organic Matter	Determination of organic matter by oxidising with potassium dichromate followed by titration with iron (II) sulphate	E010
Soil	AR	PAH - Speciated (EPA 16)	Determination of PAH compounds by extraction in acetone and hexane followed by GC-MS with the use of surrogate and internal standards	E005
Soil	AR	PCB - 7 Congeners	Determination of PCB by extraction with acetone and hexane followed by GC-MS	E008
Soil	D	Petroleum Ether Extract (PEE)	Gravimetrically determined through extraction with petroleum ether	E011
Soil	AR	pH	Determination of pH by addition of water followed by electrometric measurement	E007
Soil	AR	Phenols - Total (monohydric)	Determination of phenols by distillation followed by colorimetry	E021
Soil	D	Phosphate - Water Soluble (2:1)	Determination of phosphate by extraction with water & analysed by ion chromatography	E009
Soil	D	Sulphate (as SO4) - Total	Determination of total sulphate by extraction with 10% HCl followed by ICP-OES	E013
Soil	D	Sulphate (as SO4) - Water Soluble (2:1)	Determination of sulphate by extraction with water & analysed by ion chromatography	E009
Soil	D	Sulphate (as SO4) - Water Soluble (2:1)	Determination of water soluble sulphate by extraction with water followed by ICP-OES	E014
Soil	AR	Sulphide	Determination of sulphide by distillation followed by colorimetry	E018
Soil	D	Sulphur - Total	Determination of total sulphur by extraction with aqua-regia followed by ICP-OES	E024
Soil	AR	SVOC	Determination of semi-volatile organic compounds by extraction in acetone and hexane followed by GC-MS	E006
Soil	AR	Thiocyanate (as SCN)	Determination of thiocyanate by extraction in caustic soda followed by acidification followed by addition of ferric nitrate followed by colorimetry	E017
Soil	D	Toluene Extractable Matter (TEM)	Gravimetrically determined through extraction with toluene	E011
Soil	D	Total Organic Carbon (TOC)	Determination of organic matter by oxidising with potassium dichromate followed by titration with iron (II) sulphate	E010
Soil	AR	TPH CWG (ali: C5- C6, C6-C8, C8-C10, C10-C12, C12-C16, C16-C21, C21-C34, aro: C5-C7, C7-C8, C8-C10, C10-C12, C12-C16, C16-C21, C21-C35)	Determination of hexane/acetone extractable hydrocarbons by GC-FID fractionating with SPE cartridge for C8 to C35. C5 to C8 by headspace GC-MS	E004
Soil	AR	TPH LQM (ali: C5-C6, C6-C8, C8-C10, C10-C12, C12-C16, C16-C35, C35-C44, aro: C5-C7, C7-C8, C8-C10, C10-C12, C12-C16, C16-C21, C21-C35, C35-C44)	Determination of hexane/acetone extractable hydrocarbons by GC-FID fractionating with SPE cartridge for C8 to C44. C5 to C8 by headspace GC-MS	E004
Soil	AR	VOCS	Determination of volatile organic compounds by headspace GC-MS	E001
Soil	AR	VPH (C6-C8 & C8-C10)	Determination of hydrocarbons C6-C8 by headspace GC-MS & C8-C10 by GC-FID	E001

D Dried
AR As Received



DETS Ltd
Unit 1, Rose Lane Industrial Estate
Rose Lane
Lenham Heath
Maidstone
Kent ME17 2JN
Tel : 01622 850410

List of HWOL Acronyms and Operators
DETS Report No: 23-11457
Hydrock
Site Reference: Maw Green
Project / Job Ref: 28480
Order No: PO28511
Reporting Date: 11/10/2023

Acronym	Description
HS	Headspace analysis
EH	Extractable Hydrocarbons - i.e. everything extracted by the solvent
CU	Clean-up - e.g. by florisil, silica gel
1D	GC - Single coil gas chromatography
2D	GC-GC - Double coil gas chromatography
Total	Aliphatics & Aromatics
AL	Aliphatics only
AR	Aromatics only
#1	EH_2D_Total but with humics mathematically subtracted
#2	EH_2D_Total but with fatty acids mathematically subtracted
<u> </u>	Operator - underscore to separate acronyms (exception for +)
+	Operator to indicate cumulative eg. EH+HS_Total or EH_CU+HS_Total

Det - Acronym

Appendix G - DustTrak Data

Table F1: Monday 4th September 2023 DustTrack data – Detailed data provided upon request

Details	MG 25m far source	MG 50m far source	MG 100m far source	MG near source	MG near source	MG near source (repeat 1)	MG near source (repeat 2)	MG Site Cabins	MG Site Cabins	MG upwind	Mg upwind
Test Start Time	15:39:38	12:16:23	12:32:08	12:02:41	13:43:23	14:49:40	15:20:56	11:20:07	13:03:57	11:41:34	13:24:27
Test Start Date	04/09/2023	04/09/2023	04/09/2023	04/09/2023	04/09/2023	04/09/2023	04/09/2023	04/09/2023	04/09/2023	04/09/2023	04/09/2023
Test Length [D:H:M]	00:00:10	00:00:05	00:00:05	00:00:05	00:00:10	00:00:10	00:00:10	00:00:05	00:00:05	00:00:05	00:00:10
Test Interval [M:S]	00:05	00:15	00:15	00:15	00:05	00:05	00:05	00:15	00:15	00:15	00:05
PM1 Average [mg/m3]	0.025	0.016	0.016	0.024	0.03	0.026	0.029	0.033	0.023	0.022	0.012
PM1 Minimum [mg/m3]	0.019	0.015	0.013	0.017	0.011	0.021	0.02	0.031	0.02	0.019	0.01
PM1 Maximum [mg/m3]	0.094	0.023	0.026	0.049	0.328	0.058	0.175	0.035	0.027	0.031	0.016
PM1 TWA [mg/m3]	0	0	0	0	0	0	0	0	0	0	0
PM2.5 Average [mg/m3]	0.026	0.016	0.016	0.024	0.031	0.027	0.029	0.033	0.023	0.022	0.012
PM2.5 Minimum [mg/m3]	0.019	0.015	0.013	0.017	0.011	0.021	0.02	0.031	0.02	0.019	0.01
PM2.5 Maximum [mg/m3]	0.096	0.023	0.026	0.05	0.34	0.059	0.18	0.035	0.027	0.031	0.016
PM2.5 TWA [mg/m3]	0	0	0	0	0	0	0	0	0	0	0
PM4 Average [mg/m3]	0.027	0.017	0.016	0.025	0.035	0.028	0.031	0.035	0.025	0.022	0.012
PM4 Minimum [mg/m3]	0.02	0.015	0.014	0.017	0.012	0.022	0.021	0.033	0.022	0.019	0.01
PM4 Maximum [mg/m3]	0.114	0.024	0.027	0.053	0.404	0.067	0.212	0.037	0.03	0.031	0.017
PM4 TWA [mg/m3]	0	0	0	0	0	0	0	0	0	0	0
PM10 Average [mg/m3]	0.032	0.018	0.018	0.033	0.053	0.032	0.04	0.044	0.039	0.024	0.013
PM10 Minimum [mg/m3]	0.02	0.016	0.014	0.018	0.012	0.023	0.021	0.039	0.03	0.021	0.01
PM10 Maximum [mg/m3]	0.198	0.024	0.03	0.075	0.641	0.101	0.341	0.049	0.051	0.032	0.018
PM10 TWA [mg/m3]	0	0	0	0	0	0	0	0	0	0	0
TOTAL Average [mg/m3]	0.04	0.023	0.021	0.056	0.092	0.042	0.059	0.066	0.074	0.03	0.015
TOTAL Minimum [mg/m3]	0.02	0.017	0.015	0.019	0.012	0.023	0.022	0.043	0.05	0.021	0.01
TOTAL Maximum [mg/m3]	0.285	0.037	0.043	0.223	1.72	0.194	0.559	0.084	0.125	0.058	0.043
TOTAL TWA [mg/m3]	0	0	0	0	0	0	0	0	0	0	0

Table F2: Tuesday 5th September 2023 DustTrack data – Detailed data provided upon request

Details	MG 25m far source	MG 50m far source	MG 100m far source	MG by pond	MG downwind	NG near source
Test Start Time	12:33:51	12:20:47	12:01:48	13:21:24	13:01:21	12:48:11
Test Start Date	05/09/2023	05/09/2023	05/09/2023	05/09/2023	05/09/2023	05/09/2023
Test Length [D:H:M]	00:00:10	00:00:10	00:00:10	00:00:10	00:00:10	00:00:10
Test Interval [M:S]	00:05	00:05	00:05	00:05	00:05	00:05
PM1 Average [mg/m3]	0.022	0.441	25.3	0.012	0.011	0.027
PM1 Minimum [mg/m3]	0.009	0.009	0.025	0.009	0.009	-0.017
PM1 Maximum [mg/m3]	1.22	1.13	42.2	0.028	0.017	1.31
PM1 TWA [mg/m3]	0	0	0	0	0	0
PM2.5 Average [mg/m3]	0.022	0.441	25.3	0.012	0.011	0.028
PM2.5 Minimum [mg/m3]	0.009	0.009	0.026	0.009	0.009	-0.017
PM2.5 Maximum [mg/m3]	1.22	1.13	42.2	0.028	0.018	1.31
PM2.5 TWA [mg/m3]	0	0	0	0	0	0
PM4 Average [mg/m3]	0.023	0.442	25.3	0.012	0.011	0.028
PM4 Minimum [mg/m3]	0.01	0.009	0.026	0.009	0.009	-0.017
PM4 Maximum [mg/m3]	1.22	1.13	42.2	0.033	0.019	1.31
PM4 TWA [mg/m3]	0	0	0	0	0	0
PM10 Average [mg/m3]	0.026	0.443	25.3	0.014	0.012	0.031
PM10 Minimum [mg/m3]	0.01	0.011	0.028	0.01	0.009	-0.017
PM10 Maximum [mg/m3]	1.22	1.13	42.2	0.064	0.028	1.33
PM10 TWA [mg/m3]	0	0	0	0	0	0
TOTAL Average [mg/m3]	0.033	0.452	25.4	0.016	0.014	0.043
TOTAL Minimum [mg/m3]	0.01	0.012	0.061	0.01	0.009	-0.017
TOTAL Maximum [mg/m3]	1.23	1.13	42.2	0.107	0.053	1.43
TOTAL TWA [mg/m3]	0	0	0	0	0	0

Table F3: Wednesday 6th September 2023 DustTrack data – Detailed data provided upon request

Details	MG 25m far source	MG 50m far source	MG 100m far source	MG by pond	MG downwind	NG near source	MG Office
Test Start Time	09:10:41	11:34:54	11:23:43	11:48:40	09:23:04	10:58:23	09:58:03
Test Start Date	06/09/2023	06/09/2023	06/09/2023	06/09/2023	06/09/2023	06/09/2023	06/09/2023
Test Length [D:H:M]	00:00:10	00:00:10	00:00:10	00:00:10	00:00:10	00:00:10	00:00:10
Test Interval [M:S]	00:05	00:05	00:05	00:05	00:05	00:05	00:05
PM1 Average [mg/m3]	0.615	0.089	0.043	0.051	0.095	0.056	0.035
PM1 Minimum [mg/m3]	0.377	0.043	0.038	0.044	0.068	0.048	0.027
PM1 Maximum [mg/m3]	1.03	4.51	0.087	0.069	2.28	0.238	0.051
PM1 TWA [mg/m3]	0	0	0	0	0	0	0
PM2.5 Average [mg/m3]	0.615	0.089	0.043	0.051	0.095	0.056	0.036
PM2.5 Minimum [mg/m3]	0.378	0.043	0.038	0.044	0.068	0.048	0.027
PM2.5 Maximum [mg/m3]	1.03	4.51	0.087	0.07	2.3	0.239	0.051
PM2.5 TWA [mg/m3]	0	0	0	0	0	0	0
PM4 Average [mg/m3]	0.617	0.09	0.044	0.052	0.098	0.057	0.039
PM4 Minimum [mg/m3]	0.378	0.043	0.039	0.045	0.069	0.049	0.029
PM4 Maximum [mg/m3]	1.03	4.51	0.087	0.074	2.46	0.241	0.055
PM4 TWA [mg/m3]	0	0	0	0	0	0	0
PM10 Average [mg/m3]	0.628	0.094	0.048	0.055	0.113	0.061	0.058
PM10 Minimum [mg/m3]	0.382	0.044	0.041	0.047	0.07	0.05	0.042
PM10 Maximum [mg/m3]	1.03	4.51	0.09	0.112	3.76	0.252	0.085
PM10 TWA [mg/m3]	0	0	0	0	0	0	0
TOTAL Average [mg/m3]	0.675	0.101	0.055	0.063	0.242	0.072	0.098
TOTAL Minimum [mg/m3]	0.385	0.044	0.041	0.048	0.07	0.05	0.051
TOTAL Maximum [mg/m3]	2.94	4.51	0.102	0.235	17.2	0.417	0.224
TOTAL TWA [mg/m3]	0	0	0	0	0	0	0

Table F4: Thursday 7th September 2023 DustTrack data – Detailed data provided upon request

Details	MG 50m far source	MG 100m far source	MG by pond	MG Downwind	MG near Source	MG Office
Test Start Time	11:03:54	10:51:36	11:23:10	09:33:11	09:19:31	10:05:39
Test Start Date	07/09/2023	07/09/2023	07/09/2023	07/09/2023	07/09/2023	07/09/2023
Test Length [D:H:M]	00:00:10	00:00:10	00:00:10	00:00:10	00:00:10	00:00:10
Test Interval [M:S]	00:05	00:05	00:05	00:05	00:05	00:05
PM1 Average [mg/m3]	0.03	0.027	0.028	0.045	0.208	0.034
PM1 Minimum [mg/m3]	0.023	0.024	0.023	0.039	0.044	0.028
PM1 Maximum [mg/m3]	0.085	0.033	0.036	0.083	0.627	0.046
PM1 TWA [mg/m3]	0	0	0	0	0	0
PM2.5 Average [mg/m3]	0.03	0.027	0.028	0.045	0.208	0.034
PM2.5 Minimum [mg/m3]	0.023	0.024	0.023	0.039	0.044	0.028
PM2.5 Maximum [mg/m3]	0.085	0.033	0.036	0.083	0.627	0.047
PM2.5 TWA [mg/m3]	0	0	0	0	0	0
PM4 Average [mg/m3]	0.031	0.028	0.029	0.046	0.21	0.036
PM4 Minimum [mg/m3]	0.024	0.024	0.024	0.04	0.045	0.03
PM4 Maximum [mg/m3]	0.089	0.034	0.036	0.085	0.628	0.049
PM4 TWA [mg/m3]	0	0	0	0	0	0
PM10 Average [mg/m3]	0.035	0.031	0.032	0.051	0.219	0.045
PM10 Minimum [mg/m3]	0.025	0.025	0.025	0.042	0.045	0.031
PM10 Maximum [mg/m3]	0.148	0.045	0.043	0.116	0.637	0.076
PM10 TWA [mg/m3]	0	0	0	0	0	0
TOTAL Average [mg/m3]	0.061	0.043	0.043	0.067	0.254	0.067
TOTAL Minimum [mg/m3]	0.025	0.025	0.026	0.042	0.048	0.035
TOTAL Maximum [mg/m3]	0.57	0.092	0.092	0.23	0.668	0.162
TOTAL TWA [mg/m3]	0	0	0	0	0	0

Fig 1. DustTrack 8534 Calibration certificate:

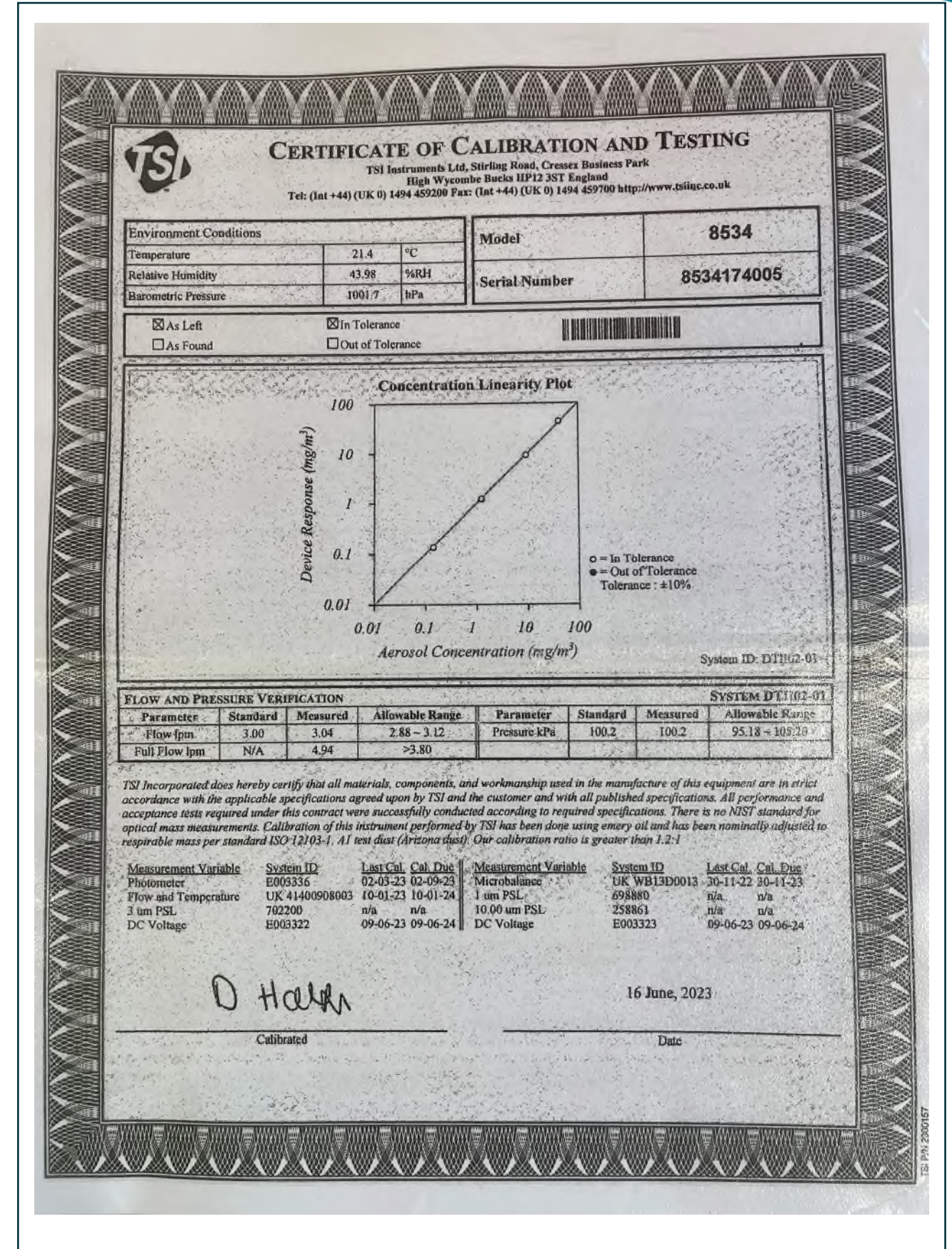

Appendix G Provectus Work Instructions

STC – WI 002 - SOIL RECEPTION PROCEDURE

Author:	Andy Clee – Ops Man	Approved By:	Jon Owens – STC Director
Distribution:	Z/QMS/Work Instructions - STC		

Document Changes

Revision No:	Summary of Changes	Date
5	Incorporates asbestos reception procedure	16.12.2022

Introduction

This procedure relates to the measures to be undertaken for the assessment of data and inspection of waste received at the soil treatment facility. It allows rejection of non-conforming waste to ensure no contaminated soils are accepted which cannot be treated by the treatment facility to a standard suitable for reuse, or which breach the list of permitted wastes as shown in the site’s Environmental permit.



Principle of Operation

The inspection will allow the following to be assessed prior to acceptance:

1. Presence of untreatable and hazardous materials (e.g. tars, clinker, asbestos insulation etc.) in the contaminated soil.
2. Presence of excessive litter/debris in the contaminated soil.
3. Compliance with the previously supplied chemical/physical analysis information (supplied by waste producer).
4. Potential for the waste to behave as a liquid or have free water/oil in the waste

If the waste material is not compliant with the agreed conditions of the Environmental Permit and pre-acceptance assessment, then the waste will be declined/rejected. As a note, if the STC is permitted to accept asbestos the forms of untreatable asbestos described in point 1 are predominantly insulation products as follows in Table 1.

Table 1. Unacceptable Forms of Asbestos Insulation Products

Form of asbestos	Example
Asbestos pipe lagging	
Loose asbestos fill	

Asbestos insulation board (AIB)	
---------------------------------	--

Procedure

Pre-Acceptance Assessment

Pre-acceptance is undertaken by Provectus to confirm treatability to meet the reuse criteria. A set of Terms and Conditions for acceptance are sent to the Waste Producer/client including a clear statement of any waste characterisation samples that are deemed untreatable. These are agreed in writing between the Waste Producer/client and Provectus prior to an authorisation number (contract line) being issued by FCC at the weighbridge for deposit at the Soil Treatment Facility.

Where data gaps exist or queries remain about the suitability of material for treatment, Provectus or FCC will offer to attend the site of origin to undertake pre-acceptance analysis and visually inspect the material and obtain further information about the waste description. Alternatively, the material may be quarantined on arrival at the STF and subject to further testing.

If the moisture content of the material is >30% then the potential for free water or oil will be further reviewed. Where moisture contents are at this level and the material does not behave as a liquid, have the potential for releasing water/oil etc and is suitable for the site infrastructure then it would be accepted on a case by case basis. Material must be able to support its own weight and ideally be able to be formed into a larger batch.

Should either Provectus, or after consultation, FCC determine that there is the high potential for material to contain untreatable inclusions or to behave as a liquid or contain free water or oil then the waste will be rejected for acceptance.

Duty of Care Documentation

No tipping on the STC will be permitted without relevant duty of care documentation from the waste producer. With this information, the job can be set up with FCC and a DW number issued to the client. All loads must be accompanied with the correct paperwork which must be checked on-site at the STC to ensure that the load is indeed destined for the STC, and that the documents are correctly completed. The consignee section of Consignment notes, for hazardous waste, and waste transfer notes for non-hazardous waste, shall be completed by Provectus at the STC once the load has been deemed acceptable by the STC site manager.

Health and Safety

The STC manager is to provide guidance on where the soil is to be tipped, and any relevant safety information prior to tipping of soil. On STC's where asbestos is permitted, it is crucial that loads are placed in the correct tipping areas.

Technicians and site personnel are to stand well away from the lorry when tipping to avoid any crush injuries/incidents as a result of being in close proximity to the tipping lorry. Any drivers must be informed of the requirement to wear a hard hat and high visibility vest when outside of the lorry cabin.

Lorries shall be informed to check that any waste/debris is removed from their lorry prior to leaving the STF.

If loads are to be tipped into the asbestos area, then additional site-specific driver rules apply and must be adhered to.

Visual Inspection: Waste Input

The following locations will be used for accepting wastes:

- Hydrocarbons only: biopile treatment area
- Asbestos only, or asbestos and hydrocarbons: designated asbestos processing area

The following plant and personnel are required as part of this procedure:

- Provectus STC manager
- Excavator

Each load of soil for inspection (new jobs) will be tipped onto the designated area. The STC manager will inform the tipper lorry driver to remain at the tipping area until the inspection has been completed.

In the event of the material containing free water or oil, the load will be immediately rejected.

In the event of untreatable forms of asbestos being present, the load will be immediately rejected

If the STC is not permitted to accept asbestos, any asbestos found will result in a rejection

The excavator will be used to expose any unsuitable materials and allow a comprehensive visual assessment. The technician will determine the next action when this has been completed, this will comprise of the following:

- Waste is accepted and tipper lorry is permitted to leave the STF with the accompanying paperwork, or;
- Waste is not accepted and the unsuitable element of waste load, either partial or complete load is removed by excavator and placed back into the tipper lorry. A rejection form is filled in on-site and both Landfill Manager (LM) and Sales Manager (SM) are informed. It is the duty of FCC to inform the Environment Agency of any rejected loads.

At the end of the formal waste acceptance procedure the soil will be prepared for processing or biotreatment. Coordination of further treatment/processing events is to be decided by the STC Manager.

Continual visual inspections are to be made by the trained excavator operator who is to inform the STC manager of any material that may be deemed unsuitable.

Chemical Analysis: Waste Input

Based on visual inspection, sampling frequency will be considered; this is in relation to the volume from each hazardous waste production site. Sampling will be undertaken on soils using composite sampling methods described in BS812.

The chemical analysis of soils generally takes 5-7 days to complete, therefore limited storage times are required. Materials will be placed into treatment as soon as practicable from the receipt of chemical analysis and formal acceptance of the waste.

The range of contaminants for analysis will be based upon the original contaminating substances. A copy of the analysis shall be checked by the STC operations manager for

verification against the original client data. In the event of non-conformity (i.e. will soils be unable to achieve the final reuse criteria), the STC operations manager shall liaise with the STC sales manager, and a decision on the next course of action will be taken.

For avoidance of doubt, the limits for asbestos from laboratory testing will be as follows:

- Chrysotile only: 0.1%
- Other forms of asbestos (or chrysotile and others): 0.01%
- Asbestos debris limited to those which can be removed as Notifiable Non-Licensed Works (NNLW) if the site is permitted to accept asbestos.

The waste will only be formally accepted once reception analyses are received and approved in accordance with Soil Assessment Procedure illustrated in STC-PR02-V2 (Figure 1) below.

Summary of Waste Reception

Figure 1 is a flow diagram for the waste reception procedure. The procedure is implemented to ensure that the waste is only formally accepted once visual inspections and chemical analysis of received wastes have been successfully completed. This ensures that any soils that are formally accepted are suitable for further soil processing/treatment. All non-compliant wastes will be rejected.

Figure 1. Summary of Waste Acceptance Procedure

STC-PR02-V2

Soil Assessment Procedure

STF – PR02 – V2

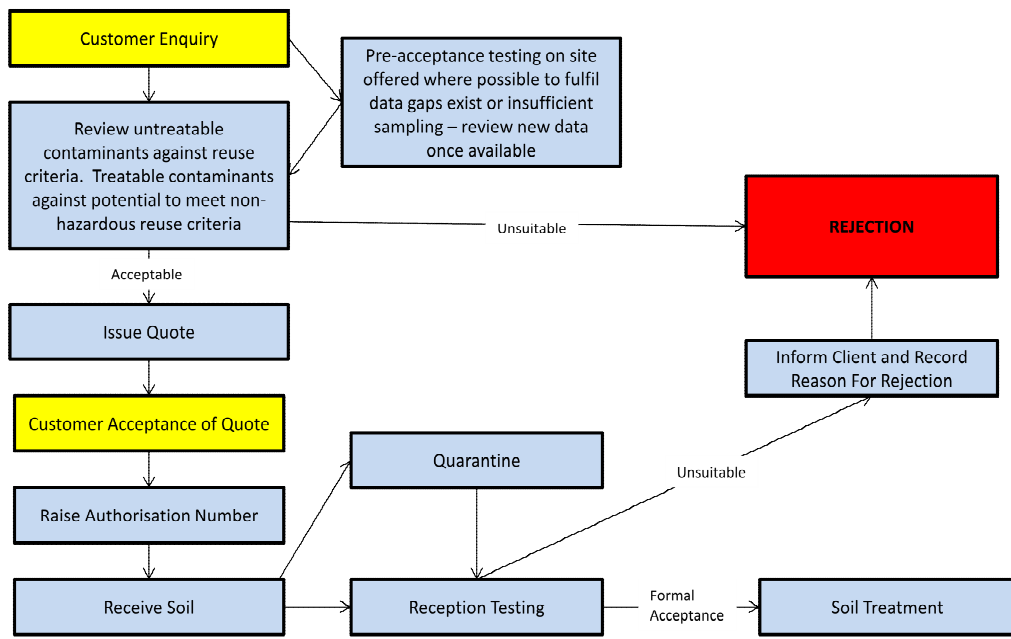

STC-PR02-V2

Soils with similar contaminants will be formed into stockpiles to enter treatment. Batches must also be formed whilst respecting the following key points:

- No mixing of hazardous and non-hazardous wastes
- No mixing of soils or pre-treated soils with non-soil wastes unless specified on the permit as a directly associated activity (e.g. use of wood wastes as a bulking agent on cohesive soils)
- No mixing of soils with different contaminant types – e.g. soils from a fuel storage source should not be mixed with soils from a former gasworks
- No mixing of soils where there is the potential for emissions that are not listed in the operating techniques or can be mitigated by the existing infrastructure

Once soils are formed into a batch for biotreatment the next steps are highlighted in STC WI 004. For asbestos contaminated soils the next steps are provided in STC WI0011.

STC – WI 003 - SOIL CHARACTERISATION PROCEDURE

Author:	Andy Clee – Ops Man	Approved By:	Jon Owens – STC Director
Distribution:	Z/QMS/Work Instructions - STC		

Document Changes

Revision No:	Summary of Changes	Date
8	Slight change in wording	14.12.22

Introduction

This procedure relates to the measures to be undertaken for the sampling of soils received at the STC. See procedure STC – WI 002 Soil Reception for background information.

Objectives

The main objective of the operation is to ensure soils received at the Soil Treatment Centre (STC) are visually, structurally, and chemically similar to those described by the waste producer/client during pre-acceptance, and therefore compliant with the Environmental permit and suitable for treatment and reuse. This will allow any non-conforming waste to be rejected.

Procedure

The sampling of soils will be performed by the STC technician or STC site manager. The procedure follows composite sampling methods as described in BS812.

A minimum of at least one composite sample must be taken from each job (unique authorisation code/DW number) and at the frequency highlighted in Table 1 below. Chemical testing is undertaken to ensure that the material being tipped is consistent with the analysis and description provided by the client at the pre-characterisation stage. It also checks to see if the material remains consistent throughout the project.

Table 1: Requirements for sampling:

Volume of soil (t)	No. of samples needed (before or during acceptance at STC)
< 100	1
100 - 500	2
500 +	2 + 1 for every 500t

The general suite of analysis for soils shall include:

- pH
- CLEA Metals
- Total TPH
- Total PAHs
- Total Cyanide

- Phenols
- SVOCs and VOCs (where required)
- PCBs (where required)
- Asbestos (screen and quantification where asbestos is identified)
- Moisture content

These parameters may be adapted by the STC operations manager or FCC compliance due to prior knowledge of contaminants derived from client waste description, history and data.

Liquid oil phase wastes are not permitted for treatment at the site.

All analysis will be undertaken by a UKAS/MCERTS accredited laboratory using accredited methods.

Once the analysis results are received, they will be assessed by a suitably qualified and experienced STC manager to confirm they meet the requirements for treatment. These results are to be stored electronically onto the STC server.

Where possible, the soils are to be placed into a batch with similar contamination level. The receiving batch has contaminant limits (these are not contaminant limits for soil inputs which can vary and exceed the average batch limits). The hydrocarbons in the batches will be limited to an average as shown in Table 2.

Concentrations for inorganics to be reviewed in accordance with WM3 (Jan 2021).

Asbestos concentrations to be assessed using criteria in Table 3.

Should the results not conform to the requirements for treatment the waste will be rejected following the formal rejection procedure.

Table 2. Maximum Average Contaminant Concentrations for Receiving Batch

Substance	Carbon Range	Lower Elimination Rate	Upper Elimination Rate	Maximum average batch concentration (lower level) - mg/kg	Maximum average batch concentration upper level) - mg/kg	Comments
Petrol range organics	C6-C10	95%	99%	20,000	100,000	Limited by odour potential
Diesel	C10-C25	60%	90%	2,500	10,000	Target of below 1,000mg/kg for reuse even though diesel is only hazardous at 1% (10,000mg/kg)
Lube Oils	C25+	40%	65%	1,667	2,857	Review age of spill and soil type before assessing which elimination rate to use
Unknown Oil	C10+	40%	80%	1,667	5,000	Review age of spill, source and soil type before assessing which elimination rate to use
PAHs	C10+	30%	90%	1,429	10,000	Limited by odour potential
Phenols	C6+	90%	99%	10,000	100,000	Limited by odour potential
Solvents	C2+	95%	99%	20,000	100,000	Limited by odour potential
VOCs	C2+	99%	99%	100,000	100,000	Limited by odour potential

Table 3. Maximum Asbestos Contaminant Concentrations for Treatment

Substance	Maximum concentration (%)	Comments
Chrysotile	<0.1%	Bound forms of ACM only
Amphibole ACM Types	<0.01%	Bound forms of ACM only
Asbestos insulation/unbound asbestos	Absent	No acceptance of any form of asbestos in friable/insulation form

STC – WI 006 - SOIL ANALYSIS

Author:	Andy Clee – Ops Man	Approved By:	Jon Owens – STC Director
Distribution:	Z/QMS/Work Instructions - STC		

Document Changes

Revision No:	Summary of Changes	Date
5	Minor alteration to wording	14.12.2022

Introduction

This procedure relates to the measures to be undertaken for the testing of soils treated at the Soil Treatment Centre (STC). This ensures that soils are suitable when received, maintained in optimal treatment ranges, and are validated in accordance with the permit. Once treatment is complete soils may be reused in several ways depending on the site. This includes quarry backfill works or restoration soil for the landfill site.

Principle of Operation

The main objective is to ensure, in accordance with the Environmental Permit, that any soil treated by Provectus is reused in a safe and environmentally acceptable manner. Quality control measures are implemented in order to prevent the reuse of soils to destinations either unintended, or unsuitable for the receipt of such soils. This operation is performed in conjunction with FCC, who operate the sites where the soils shall be reused.

In-treatment batches of soil are monitored periodically as described in STC WI 004. When a batch of treated soil displays strong chemical evidence of meeting a non-hazardous reuse standard, a 'validation' sample is to be taken and used to generate a data report. This is to be reviewed by the STC operations manager and can then be sent to FCC to be formally approved for disposal.

Validation sampling is to be carried out by the STC site technician or site manager, using a grid formation sampling plan. As a general rule one composite sample should be taken for every 500t.

The reception and validation samples should be submitted for the following analytical tests –

- Metals (As, B, Cd, Cr, Cu, Pb, Hg, Ni, Se & Zn)
- pH
- Speciated TPH (including BTEX)
- Speciated PAHs
- Phenols
- Total Sulphate
- Elemental sulphur
- Free Cyanide
- Total Cyanide
- Asbestos screen

Dependent on the contaminants of concern it may be necessary to request further parameters for testing on validation. Leachate analyses are required for reuse of soils in the restoration part of the landfill in accordance with the agreed risk assessment.

Procedure

Once the soil batch has been analysed by an accredited laboratory, and the results reviewed by the STC operations manager; a validation report shall be compiled with information regarding soil volumes, validation analysis results, soil origin and ultimate destination. This shall be communicated to both the FCC Waste Assessment team and to the FCC site manager for approval and so that provisions can be made for the transfer of soils to the approved destination. The validation report and any supporting information shall be stored on the STC server.

Appendix H Provectus letter on Maw Green and ERQ air monitoring

Simon Cole
Hydrock
3rd Floor, Wharton Place,
13 Wharton Street,
Cardiff,
CF10 1GS

19 January 2024

Dear Simon

Location of Asbestos Sampling Points and Soil Sampling Methodology

Further to your request for the confirmation on the asbestos monitoring that was undertaken at the Maw Green site.

The drawing shown in Appendix 1 was included in the mobile treatment licence deployment. This allowed for three locations around the soil treatment equipment and one location directly next to the soil screener.

Each of the analysts reports provides a drawing showing the sampling points and reference to ensure that each of the results can be referenced to the location on site.

The pumps will occasionally alter position in relation to the soil treatment equipment as the pump next to the soil screener is always located on the downwind side of the shaker decks.

In the event of rain, the pump would be placed underneath the conveyor arm rather than to the side of it to prevent the filters being spoiled.

Should there be significant oversize then the location would be chosen to ensure that the oversize material stockpile has no potential for spilling into and overwhelming the pump during the sampling period.

All these points result in the location of the pump slightly changing location on a day to day basis, but it would always be located in close proximity of the soil screener (i.e. <5m) from the shaker decks.

An example of the pump location next to a screener conveyor and shaker decks as shown in Figure 1. This sampling location was then analysed using SEM analysis to provide the lower detection limit of <0.0005f/ml.



Figure 1. Asbestos sampling pump in relation to soil screener

The soil sampling undertaken prior and during the Hydrock independent work was undertaken using the Hydrock procedure ref: 28480-HYD-XX-XX-TN-GE-0003. This sampling allowed for an assessment of asbestos fibres in soil from the treatment pad and in soils before and after soil screening.

With respect to the reporting of asbestos data to the Environment Agency. The Maw Green site was initially operated under a mobile treatment licence deployment ref: EB3636AK/W0028 from mid August 2022, and then after 20 July 2023 under installation permit ref: EPR/BS7722ID/V009. Whilst we monitored asbestos concentrations daily on site, neither of these permits had a formal requirement for the reporting of asbestos monitoring data within the quarterly reports. However, all asbestos monitoring data was available to the local enforcement officers to review during their regular compliance visits.

All asbestos monitoring data for Edwin Richards Quarry (permit ref: EPR/HP3632RP) has been issued to the Environment Agency in accordance with Table s4.1 of the installation permit.

If there is any further confirmation required on the points above, please do not hesitate in contacting me.

Regards



Jon Owens
Director



Provectus Soils Management Limited
Regent House, Bath Avenue
Wolverhampton, WV1 4EG
T: 01902 810084
E: info@provectusgroup.com
www.provectusgroup.com

Appendix 1 – Sampling Locations

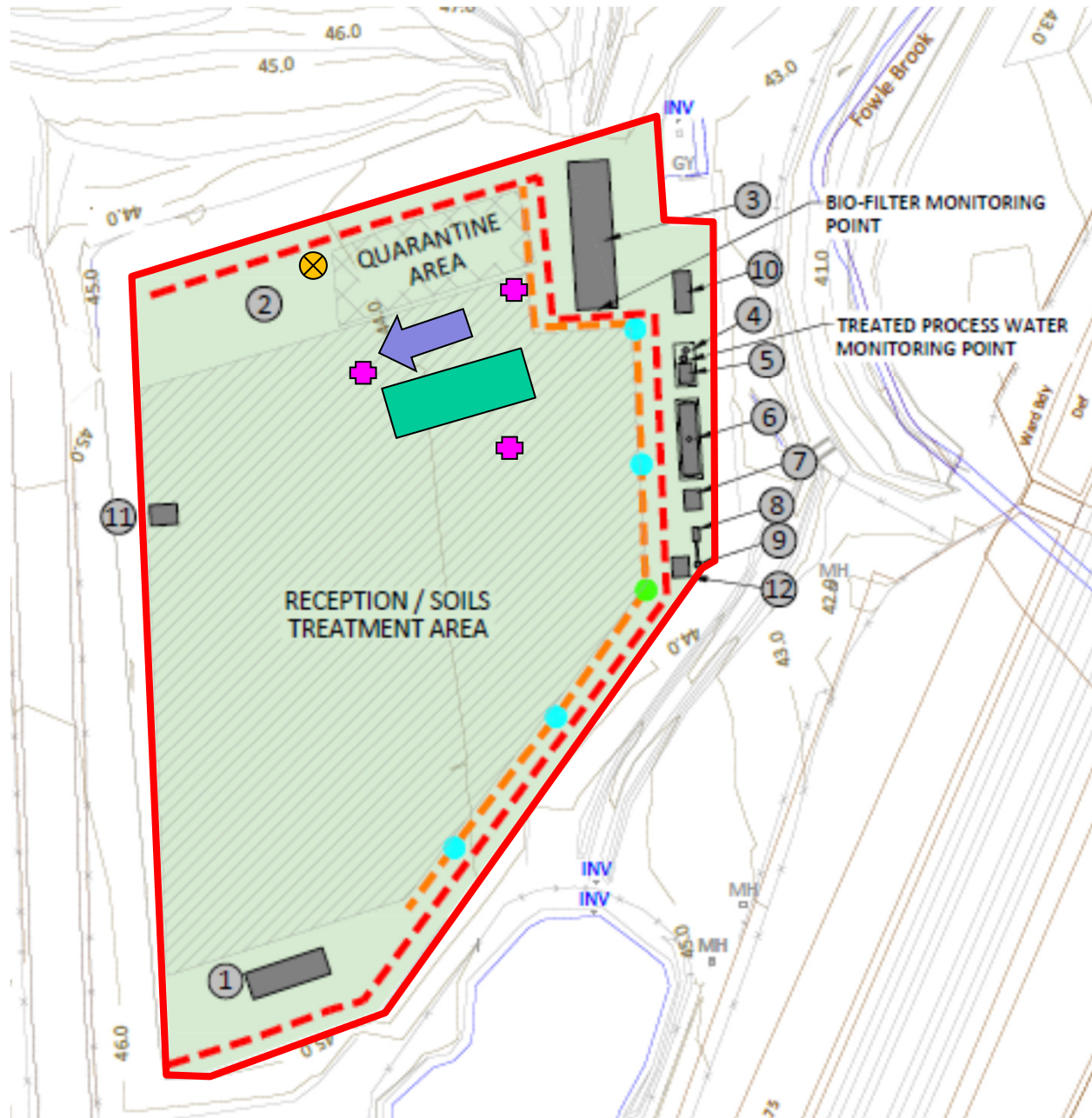

Existing Infrastructure

- LEGEND**
- CONCRETE IMPERMEABLE PAVING
 - BOUNDARY KERB LINE
 - WATER DRAINAGE PIPE
 - DRAINAGE GULLY
 - PUMPING CHAMBER
 - 1 SITE OFFICE
 - 2 NUTRIENT STORAGE
 - 3 BIOFILTER
 - 4 GRANULAR ACTIVATED CARBON FILTERS
 - 5 TRANSFER TANK
 - 6 PROCESS WATER SETTLEMENT TANK
 - 7 10h CONTAINER WITH CONTROL PANEL
 - 8 BLOWER
 - 9 AIR WATER SEPARATOR
 - 10 20h TOOL STORE
 - 11 FUEL STORAGE
 - 12 3VV

MTL Infrastructure

- Soil Screener
- Picking Station
- Air sampling: asbestos
- Lockable Skip: asbestos
- Extent of MTL boundary



Provectus Remediation Ltd
 Wyvols Court
 Swallowfield
 Reading
 RG7 1WY

Tel. 0118 988 0218
 www.provectusgroup.com

Client: FCC Environment

Project: MTL Layout: Maw Green

Job No.: 100993/MTL

Title: Site Layout

Scale: NTS

Date Drawn: May 2022

Drawing No.: 100993/MTL – Asbestos DWG4/Rev1

Appendix I Screener manufacturer information

Keestrack



Performance in every detail

K3 SCALPER

| Belgium | Czech | China | Italy | India | USA |

K3 SCALPER



TECHNICAL SPECIFICATIONS

Feed hopper	
Capacity	3,5 m ³
Discharge height	2.410 mm
Plate apron feeder	
Dimension (width x length)	1.000 x 3.150 mm
Feed capacity	Up to 250 t / h
Vibrating screen	
Screen type	Double deck
Dimension (width x length)	1.200 x 2.700 mm
Belt conveyor	
Fine fraction conveyor (width x length)	650 x 8.000 mm (Hydraulically foldable)
Middle fraction conveyor (width x length)	650 x 8.000 mm (Hydraulically foldable)
Coarse conveyor (width x length)	1.000 x 5.000 mm (Hydraulically foldable)

Track-unit	
Dimension (width x length)	400 x 2.965 mm
2 speeds	1,1 / 1,9 km / h
Engine unit	
Power	55,4 kW / 1.800 rpm
Fuel tank	280 l
Hydraulic oil tank	220 l
Control	
Type	PLC - IP67
Display	3,5" LCD
Controller	Remote control

OPTIONS

Magnetic separator	
Magnetic power	400 GAUSS (250 mm distance)
Anti clogging system	
Application	Separation of sticky material
Screen flow brake	
Application	Increase screening efficiency

Picking station	
Position	On either side
Radio remote control	
Type	Handheld, multi functions remote control
Working light	
No. of lamps	4 pieces

OPTIONAL MODEL

K3 _e scalper hybrid version
--

TRANSPORT DIMENSIONS AND WEIGHT

Length : 9.800 mm
Height : 3.120 mm
Width : 2.550 mm
Weight : 17 t without options

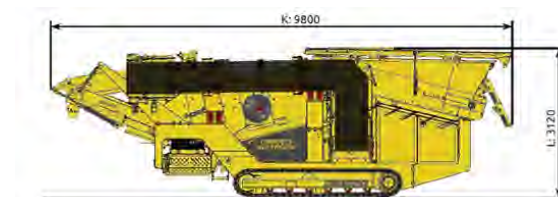

Keestrack



Performance in every detail

K4 SCALPER

| Belgium | Czech | China | Italy | India | USA |

K4 SCALPER

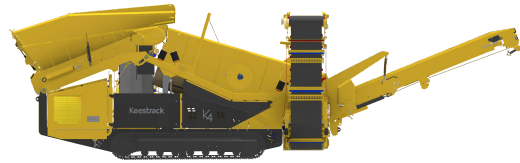

TECHNICAL SPECIFICATIONS

Feed hopper	
Capacity	7 m ³
Discharge height	3.336 mm
Plate apron feeder	
Dimension (width x length)	1.120 x 3.150 mm
Feed capacity	Up to 350 t / h
Vibrating screen	
Screen type	Double deck
Dimension (width x length)	1.500 x 4.200 mm
Belt conveyor	
Fine fraction conveyor (width x length)	900 x 8.350 mm (Hydraulically foldable)
Middle fraction conveyor (width x length)	800 x 8.280 mm (Hydraulically foldable)
Coarse conveyor (width x length)	1.200 x 5.000 mm (Hydraulically foldable)

Track-unit	
Dimension (width x length)	400 x 3.310 mm
2 Speeds	1,3 - 2,2 km / h
Engine unit	
Power	55 kW or 88 kW
Fuel tank	280 l
Hydraulic oil tank	220 l
Control	
Type	PLC - IP67
Display	4,3" LCD
Controller	Remote control

OPTIONS

Anti clogging system	
Application	Separation of sticky material
Screen flow brake	
Application	Increase screening efficiency
Picking station	
Position	On either side

Coarse conveyor (long version)	
Dimension (width x length)	1.200 x 6.800 mm
Radio remote control	
Type	Handheld, multi functions remote control
Working light	
No. of lamps	4 pieces

OPTIONAL MODEL

K4_e scalper hybrid version

TRANSPORT DIMENSIONS AND WEIGHT

Length : 10.681 mm
 Height : 3.130 mm
 Width : 2.550 mm
 Weight : 26,5 t without options

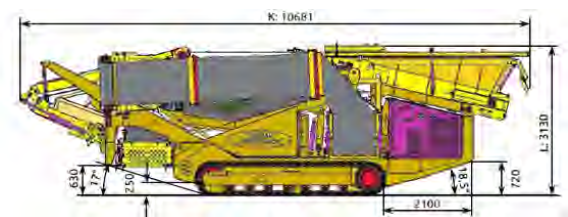



Performance in every detail

K6 SCALPER

| Belgium | Czech | China | Italy | India | USA |

K6 SCALPER



TECHNICAL SPECIFICATIONS

Feed hopper	
Capacity	8 m ³
Discharge height	3.260 mm
Plate apron feeder	
Dimension (width x length)	1.300 x 3.560 mm
Feed capacity	Up to 600 t / h
Vibrating screen	
Screen type	Double deck
Dimension (width x length)	1.800 x 4.500 mm
Belt conveyor	
Fine fraction conveyor (width x length)	1.000 x 8.650 mm (Hydraulically foldable)
Middle fraction conveyor (width x length)	800 x 8.500 mm (Hydraulically foldable)
Coarse conveyor (width x length)	1.500 x 6.500 mm (Hydraulically foldable)

Track-unit	
Dimension (width x length)	450 x 3.720 mm
2 Speeds	1,1 - 2 km / h
Engine unit	
Power	88 kW / 1.800 rpm
Fuel tank	330 l
Hydraulic oil tank	370 l
Control	
Type	PLC - IP67
Display	4,3" LCD
Controller	Remote control

OPTIONS

Magnetic separator	
Magnetic power	400 GAUSS (300 mm distance)
Anti clogging system	
Application	Separation of sticky material
Screen flow brake	
Application	Increase screening efficiency
Walkway along the screen	
Position	On either side

Picking station	
Position	On either side
Coarse conveyor (XXL version)	
Dimension (width x length)	1.500 x 9.063 mm
Radio remote control	
Type	Handheld, multi functions remote control
Working light	
No. of lamps	4 pieces

OPTIONAL MODEL

K6_e scalper hybrid version

TRANSPORT DIMENSIONS AND WEIGHT

Length : 13.360 mm
 Height : 3.180 mm
 Width : 2.720 mm
 Weight : 30 t without options





Applications:

- Fine screening
- Screening of difficult, sticky or wet materials to an infinite variety of sizes
- Recycling
- Compost & peat
- Aggregates
- Wood
- Sand and gravel
- Iron, steel & metal
- Concrete
- Asphalt and others

Features & Benefits:

- 3 side accessibility for Engine maintenance.
- Load Sensing hydraulic system for low fuel consumption.
- Steel plate apron feeder.
- Cassette system for wire mesh replacement.
- Hydraulically liftable option at feeding end for Easy screen maintenance.
- Special Engineered design for uniform screening efficiency across each deck.
- Multiple top deck and bottom deck options to suit most Screening applications.
- All three hopper walls are hydraulically fold-able.
- Keestrack-er telematics-optional.

Screen:

Two bearing, three deck screenbox (4 way split)
Size: 6000 mm X 2000 mm
Adjustable stroke & stroke angle

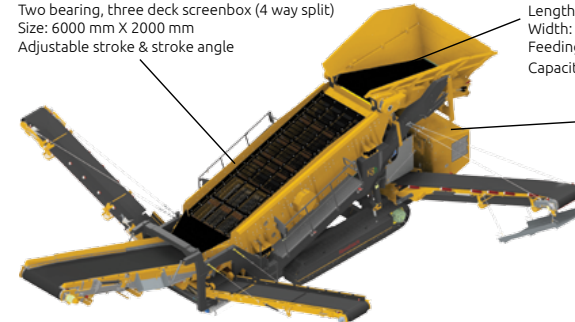

Hopper:

Wear Resistant Feed Hopper HB450
Length: 4950 mm
Width: 4900 mm
Feeding Height: 3500 mm
Capacity: 10 m3

Power Unit:

CATERPILLAR C4.4; fixed speed,
Emission stage Tier 3; EU STAGE IIIA;
98 kW at 1800 R.P.M
Fuel tank Capacity: 340 L.

	Transport Dimensions	Working Dimensions
Weight	44,5 t (49 sT)	
Length	16.200 mm (53'2")	17.400 mm (57'1")
Height	3.625 mm (11'11")	4.370 mm (14'4")
Width	3.000 mm (8'10")	14.800 mm (48'7")

