

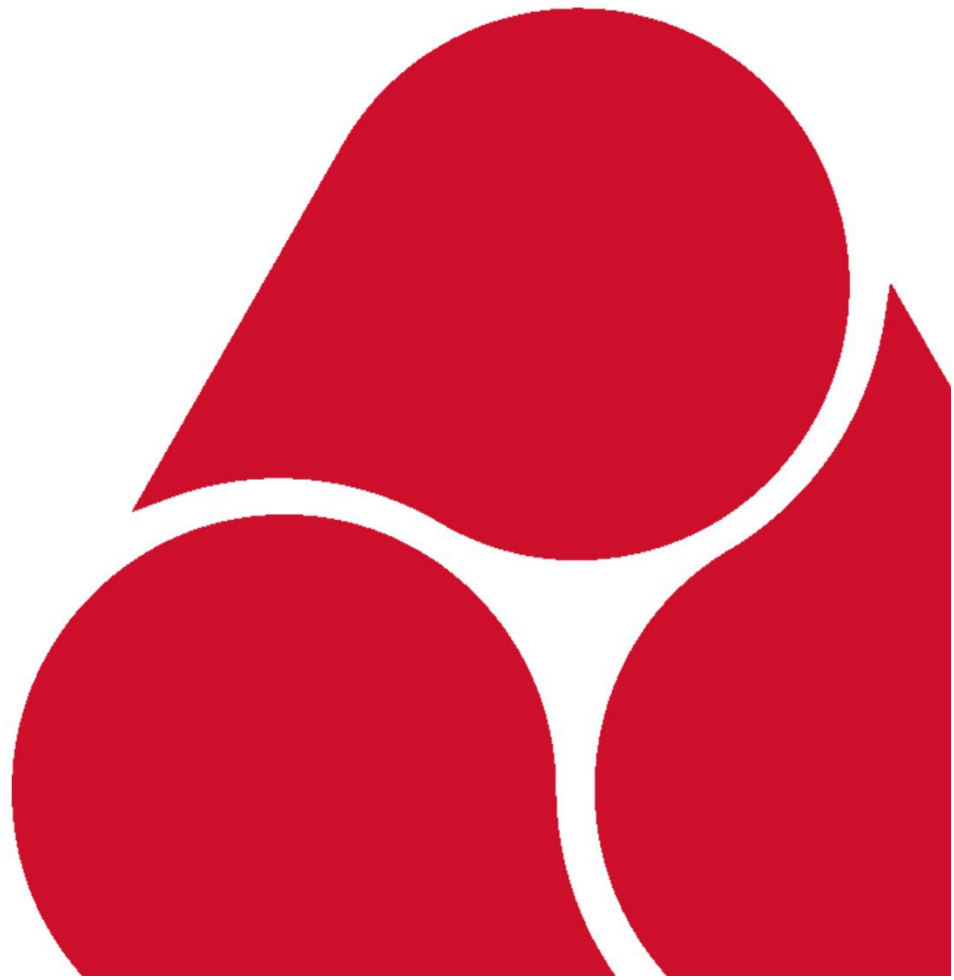

Office for Product  
Safety & Standards

# In Service Testing (IST) Handbook

March 2024



---

**This guide is designed to provide all parties with an interest in, In Service Testing, or undertaking an alternative IST regime, with an understanding of the IST methodology and an overview of timescales and testing requirements. It applies to domestic type gas meters and whole current electricity meters approved under the Measuring Instruments Directive (2004/22/EC or 2014/32/EU) or The Measuring Instruments Regulations (SI 2016/1153 - as amended).**

# Contents

1.0 Background	4
2.0 Introduction	6
3.0 Methodology overview	8
4.0 What is an MID meter?	9
5.0 Definition of meter populations	11
6.0 Time intervals for In Service monitoring	13
7.0 Sampling plan and criteria for meter populations requiring replacement	14
8.0 Assessment of results – including criteria	16
9.0 Removal of unacceptable populations	22
10.0 Assessment failures (appeals and investigations)	23
Annex 1 – Testing timetable	25
Annex 2 – Approved test stations	27
Annex 3 – Drawing of samples and test requirements	30
Annex 4 – Rust / corrosion guide for gas meter cases	39
Annex 5 – Electricity meter testing example	44
Annex 6 – Worked example	46
Annex 7 – Calculation of AQL values	49
Annex 8 – Treatment of electricity meter super populations assessed individually	54
Annex 9 – Measuring Instruments Directive	55
Annex 10 – Testing of nationally approved electricity meters for extending certification period	56
Annex 11 – Reference documents	59
Annex 12 – General definitions	60
Annex 13 – IST4 membership	63

## 1.0 Background

The statutory responsibility for the metrological performance of gas and electricity meters was transferred from the Gas and Electricity Markets Authority (i.e. Ofgem), the energy regulator, to the Secretary of State on 1st April 2009. These functions are currently fulfilled by The Office for Product Safety & Standards, part of the Department for Business and Trade.

In the United Kingdom, prior to October 2006, most gas and electricity meters were placed on the market under national legislation in accordance with the requirements of the Gas Act 1986 and the Electricity Act 1989. In October 2006, the Measuring Instruments Directive (MID) 2004/22/EC was implemented which allowed for the free movement of weighing and measuring instruments (including gas and electricity meters) across the European Union. This Directive was repealed in April 2016 and replaced by the recast MID 2014/32/EU.

Meters approved under the MID are required to have the CE marking to indicate conformance with relevant EU directives. However, the MID is only applicable to meters up to the point at which they are first placed on the market. Once in service, the national provisions set out in the Gas and Electricity Acts apply.

From 1 January 2021 all new meter designs/types must be approved against the requirements of the [Measuring Instruments Regulations \(MIR\) \(SI 2016/1153\)](#), as amended by the [Product Safety & Metrology etc. \(Amendment etc.\) Regulations \(EU Exit\) \(SI 2019/696\)](#), and have the UKCA (UK Conformity Assessed) mark placed on them to indicate conformance to the MIR. There is a four-year transition period, where current CE marked meters can continue to be placed on the market within GB until the 31st of December 2024. On 1st August 2023, the UK government announced the intention to extend recognition of the CE marking for placing on the market in GB indefinitely, i.e. beyond the 4-year Transition Period.

We envisage the first testing of UKCA marked meters will commence according to the rules outlined in this handbook, from 2024 for gas and 2027 for electricity meters. The new marking is explained in section 4.0 example 3 and further details with regards to UKCA meters will be added to this handbook at a later date.

The MID for 'Gas Meters and Volume Conversion Devices' Annex IV (MI-002) is implemented by [The Measuring Instruments Regulations \(SI 2016/1153\)](#)<sup>1</sup> and meters placed on the market in accordance with these regulations are "deemed to be stamped" as required by Section 17 of the [Gas Act 1986](#). As with meters approved under national legislation, there is no defined service period for MID gas meters, and these can remain in service for as long as they conform to the legal requirements.

The MID for 'Active Electrical Energy Meters' Annex V (MI-003) is implemented by [The Measuring Instruments Regulations \(SI 2016/1153\)](#)<sup>2</sup>. Meters placed on the market in accordance with these regulations are "deemed to be of an approved pattern or construction and installed in an approved manner" as required by Schedule 7 of the

---

<sup>1</sup> Previously The Measuring Instruments (Gas Meters) Regulations (SI 2006/2647).

<sup>2</sup> Previously The Measuring Instruments (Active Electrical Energy Meters) Regulations (SI 2006/1679).

**Electricity Act 1989.** Under national legislation the vast majority of electricity meters are required to be certified and meters are issued with a defined certification life, the exception being meters used for secondary billing and to non-domestic customers where the supplier and customer may agree to dispense with this requirement. At the end of this certification period meters are no longer permitted to be used for billing and should be removed from service (although OPSS will consider extending the certification life if there is evidence that meters are still conforming to the statutory requirements). There are no such requirements for MID approved electricity meters which are “deemed to be certified” and may therefore remain in service for as long as they conform to the legal requirements.

Following a consultation with industry stakeholders, it was agreed to develop procedures for monitoring the in-service performance of MID approved gas and electricity meters to enable suppliers and asset owners to demonstrate their meter populations continued conformance to the legal requirements. This concluded with the In Service Testing (IST) 1/2 report which established the procedures and testing methodology for monitoring in service performance.

The IST 1/2 report was approved by the Industry Metering Advisory Group (IMAG) and Ofgem in 2008. Thereafter, the IST 3 report consulted on the governance arrangements for the IST scheme and the majority of stakeholders were in favour of the Secretary of State governing the scheme. Details of both reports can be found on the OPSS website, with links under Annex 11 Reference Documents.

The IST4 Group, chaired by OPSS, is responsible for the development of this handbook and the implementation of the IST scheme.

## 2.0 Introduction

This guide covers the in service testing of MID approved domestic type<sup>3</sup> gas and whole current electricity meters that are subject to legal metrological control for the purpose of consumer protection and with a population size of an individual meter make/type model greater than (or equal to) 1,201. Following the introduction of UKCA marking in 2021, this guide will cover UKCA marked meters based on the current guidance listed in this handbook, when the testing schedule is reached<sup>4</sup>. It is intended to be a minimum process for assessing legislative compliance.

For the purpose of this document domestic type gas meters are defined as a meter with a maximum flow rate ( $Q_{max}$ ) not exceeding 6 m<sup>3</sup>/h, and electricity meters are Single Phase and Polyphase whole current meters<sup>5</sup> (i.e. excluding meters used with Current Transformers (CT's)).

This guide has been prepared to provide the methodology and guideline procedures for the in service testing of MID-approved gas and electricity meters to ensure those responsible for the meters, show continued compliance with the MID implementing regulations and other relevant legislation. Adoption of this guide shall assist a supplier to demonstrate they have conformed to the requirements of Schedule 2B section 3(3) of the **Gas Act 1986** (as amended) and Schedule 7 section 10(2) of the **Electricity Act 1989** (as amended). Should a supplier wish to utilise an alternative method for maintaining the accuracy of its meter population, the onus will lie with that supplier to demonstrate to OPSS that the alternative method is equivalent to, or better than, the approach described in this document.

Finally, this guide defines the test criteria to be undertaken by meter test stations approved by OPSS for testing the samples and sets out methods for the assessment of an overall population against defined criteria.

### **Note:**

*The Gas Act Owner (GAO) or Electricity Supplier has a legal duty to ensure that meters are deemed to be stamped (gas meters) or certified (electricity meters) and continue to comply with the MID implementing regulations; however this responsibility may be passed onto their MAPs (Meter Asset Providers) or MEMs (Metering Equipment Managers) through a service contract.*

*Application of IST via this guide may also be used by OPSS to control the certification life of electricity meters approved under GB national legislation. (see Annex 10)*

---

<sup>3</sup> IMAG agreed the IST methodology may not be suitable for monitoring the smaller populations of larger capacity meters.

<sup>4</sup> UKCA marked meters are approved under the MIR as amended by the Product Safety & Metrology etc. (Amendment etc.) Regulations (EU Exit) (SI 2019/696).

<sup>5</sup> As agreed by the IST 4 Electricity Subgroup on 24th September 2015.

*The CoMCoP<sup>6</sup> (Consolidated Metering Code of Practice) for Metering Equipment Managers and Approved Meter Installers) requires MEMs to maintain meters in proper working order for registering the quantity of gas and electricity supplied. This can be achieved by an appropriate maintenance regime or by sample testing as described in sub-section 23.3. IST provides a method whereby MEMs can fulfil this requirement.*

*The legacy terms MAM (Meter Asset Manager) and MOP (Meter Operator) may still be used by industry instead of MEM.*

---

<sup>6</sup> <https://recportal.co.uk/the-rec-public->

## 3.0 Methodology overview

The method used for IST is based on the requirements of **BS 6002-1:1993 (ISO 3951:1989) Sampling Procedures for Inspection by Variables**.

The IST scheme tests samples of meters which are representative of those in service with customers, the number of samples (based on population size) being in accordance with the above standard. OPSS allocates samples to each supplier in proportion to the number of meters in that supplier's portfolio. The suppliers acquire their allocated meters and send these to an appropriate test station.

The samples are tested against the IST assessment criteria, most notably accuracy. Testing is conducted by test stations approved and audited by OPSS. The suppliers receive their results from the test stations and forward these to OPSS who determine whether the meter population conforms to the assessment criteria outlined in section 8.0.

The evaluation of results from each population can be used to demonstrate a systematic approach to maintaining the accuracy of those gas and electricity meters within an individual portfolio. Where sampling of a particular meter type has been carried out by a number of parties, OPSS will compile the resulting data from these parties and analyse the results collectively so a conclusion can be reached.



## 4.0 What is an MID meter?

A meter manufactured in accordance with the MID is distinguished from nationally approved meters by the process in which it makes it to the market place and the visible markings. MID meters are approved by Notified Bodies designated by EU Member States.

The process is implemented through the application of specific annexes as set out in the Directive. These annexes relate to the conformity assessment procedures the manufacturer can choose to ensure the instrument is compliant with the Directive when placing the instrument on the market.

The three conformity assessment options available for MID approval of Gas and Electricity meters are:

- B+D (i.e. Type Examination and Quality Assurance of the Production Process)
- B+F (i.e. Type Examination and Product Verification)
- H1 (Full Quality Assurance plus Design Examination)

A meter manufacturer can have a meter type assessed against any of the assessments (B,D,F,H1), and by any EU notified body but at least one of the combinations above is required to gain MID approval.

The annexes which are applicable to gas and electricity meters are B, D, F and H1.

Annex B refers to Type Examination, where the EU notified body examines the technical design of the instrument and declares that it meets the appropriate requirements of the Directive.

Annex D refers to Declaration of Conformity to Type based on the quality assurance of the production process. This is where the manufacturer fulfils the obligations set out in the annex and ensures the instrument is in conformity with the type, as described in the EC Type Examination Certificate.

Annex F is Declaration of Conformity to Type based on product verification. This is in relation to paragraph 3 of the annex where examinations and tests to check conformity with the EC Type examination certificate are conducted.

Annex H1 is Declaration of Conformity based on full quality assurance plus design examination, where the manufacturer declares that the instrument satisfies the requirements of the Directive based upon their quality procedures and product design.

MIR meters will follow the same basic conformity assessment route as above and are assessed by Approved Bodies approved by OPSS.

MID and UKCA approved meters are distinguished by the markings affixed to the meter as shown in the following examples (page 10). MID meters will be CE marked as well as having the metrology 'M' marking in a rectangle followed by the last two-digits of the year in which the marking was affixed (i.e. generally the year the meter was manufactured). MID approved meters should also bear the number of the Annex B examination certificate.

As recommended by the UK Metering Forum (UKMF), those parties specifying meters should confirm to the serial number formats in the Technical Recommendations<sup>7</sup>.



Example 1: MID approved gas meter, with CE marking highlighted.

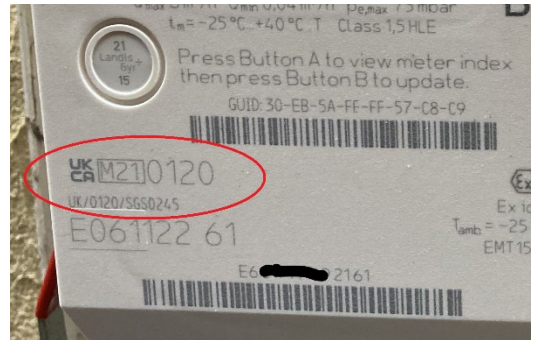

Example 2: MIR approved gas meter, with UKCA marking highlighted.

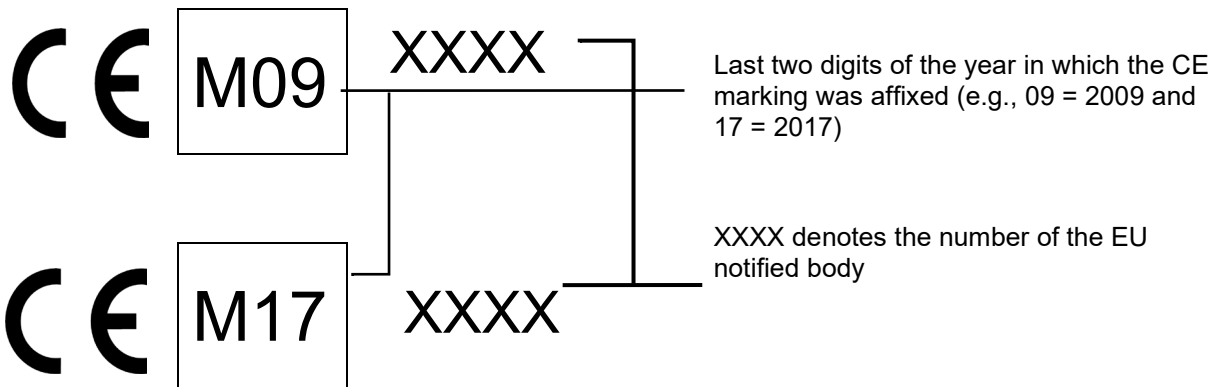

Example 3: CE marking explained

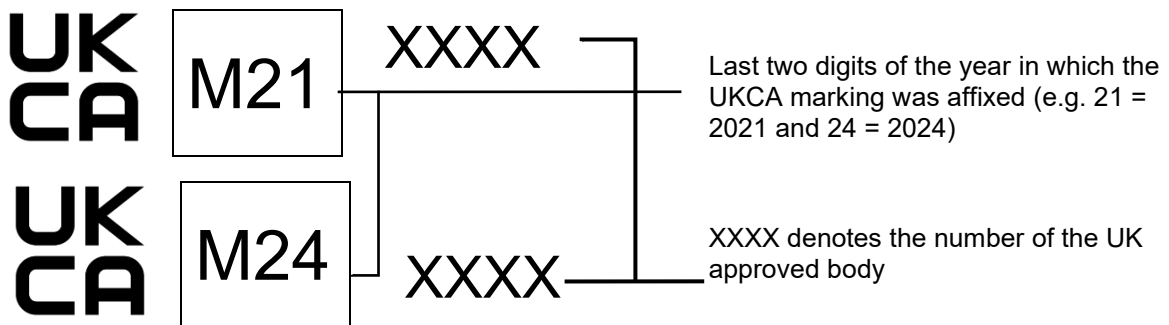

Example 4: UKCA marking explained

<sup>7</sup> <https://ukmf.org/publications/>

## 5.0 Definition of meter populations

### 5.1 Standard meter populations

In service testing by sampling should only be carried out on homogeneous populations of meters. For a population of meters to be considered homogeneous, they shall have the same characteristics, namely:

- Manufacturer
- Type or model
- Capacity/rating
- Year of manufacture
- Number of the EC type examination certificate or the EC design examination certificate

#### Electricity meters

- Number of registers (unless multi-rate version shares approval characteristics and is metrologically equivalent)

#### Gas meters

- Diaphragm material (where applicable)
- Diaphragm credit only meter populations (where applicable)
- Diaphragm pre-payment only meter populations (where applicable)
- Integral temperature conversion (where applicable)

### 5.2 Splitting of populations (sub-populations)

Meters that share the common characteristics defined above may be combined to form a single population, although this does not prevent such a population being split on other basis (e.g. by serial number range, etc.).

### 5.3 Combination of different populations

With the prior approval of OPSS combined lots of meters may be formed which are of different characteristics (e.g. single rate/two rate or different EC type certificate), provided that appropriate conditions for the assembly into such lots have been clearly stipulated by OPSS, and which are owned or managed by different parties.

### 5.4 Combination of populations of the same type of meter (super-populations)

In the case of metrologically identical electricity meters and subject to Quality Assurance control of manufacture, a meter type with a number of years since manufacture of up to, but not exceeding, five years may be combined to form a 'super population' of that type. The results obtained from tests on samples from the first year's population may be applied to subsequent years' production comprising the super-population without requiring further testing.

**Note 1:**

*Treatment of meters in this way is dependent upon the continuing consistency of metrological characteristics and, on a periodic basis, assurances should be sought from the manufacturer concerned that there have been no modifications to the pattern as submitted for EC conformity assessment which might affect such consistency.*

**Note 2:**

*This method is not considered satisfactory for gas meters where experience has shown that populations from various years of manufacture may perform differently.*

## **5.5 Repaired meters**

Meters that are repaired without disturbing the metrological seal (e.g. gas meters that have had a pressure test point replaced) are still to be considered as part of the original population to which they belonged before repair as they retain their original metrological approval.

Meters that require a new metrological seal after being repaired will have to be considered as a separate population. This is because they will have a different sealing date from similar meters manufactured at the same time. If any repair done on the meter involves a change to the meter (e.g. a change of an electronic part), this may require a new metrological approval or an extension to an existing approval.

When a meter is repaired the onus is on the person placing the meter back on the market to ensure that it meets all the requirements of the original approval.

## 6.0 Time intervals for In Service monitoring

Because of the inherent design of gas meters, and the conditions under which they are used, the accuracy may be more susceptible to variation over time. As a result, the testing period for gas meters will start sooner and they will be tested more frequently than electricity meters.

Year of manufacture of meters:  $Y$   
 Nominal Year of first assessment:  $Y + A_1$   
 Nominal Year of second assessment:  $Y + A_2$   
 Nominal Year of  $x^{\text{th}}$  assessment:  $Y + A_x$

	Testing Years	
	Gas Meters	Electricity Meters <sup>8</sup>
$A_1$	3	6
$A_2$	6	12
$A_3$	9	18
...		
...		
$A_x$	$3x$	$6x$

Table 1 – Frequency of sampling/testing (in years) of gas and electricity meter populations

For the  $x^{\text{th}}$  assessment, sampling, testing and analysis, for the purposes of this minimum process, shall not commence earlier than the start of the year  $Y+A_x$  and shall be completed (including any splitting of the population or agreed re-testing) by the end of the year  $Y+A_x+1$ .

The reference year for determining the year of manufacture shall be the two-digit year following the 'M' marking on the meter. (Example can be found in section 4)

Once a supplier (or their appointed agent) starts installing a new meter type, it will know well before the '6 year' requirements how many have been installed in years 1, 2, 3 etc.

<sup>8</sup> New testing schedule as agreed at IST 4 Electricity Subgroup meeting on the 24th September 2015, replacing previous schedule of  $8+5(x-1)$ .

## 7.0 Sampling plan and criteria for meter populations requiring replacement

The number of samples required for a known population size is given in the following table:

Population Size	Sample Size
1,201 to 3,200	50
3,201 to 10,000	75
10,001 to 35,000	100
35,001 to 150,000	150
>150,000	200

Table 2 – Sample size indexed population size

**Note 1:**

*Populations to be sampled may be the combined populations of a meter type within the control of a number of responsible persons. For example, should IST participants have a total of 140,000 meters between them of a particular meter type and year, the total sample to be obtained is 150 meters. The sample required from a particular entity shall be in proportion to the population of that meter held by the entity.*

**Note 2:**

*It is not considered that the testing of populations smaller than 1,201 will be economically viable for domestic type gas and whole current electricity meters.*

OPSS shall contact suppliers to ascertain meter population information in accordance with Annex 1 (Testing Timetable) of this document. As the total population of each meter type is required, suppliers are asked to respond as gas/electricity suppliers – not as MEMs or asset owners, etc. For each meter type OPSS will then calculate the number of samples required according to Table 2 and apportion these between the participants.

The participants are required to submit these meters for testing at one of the approved test stations detailed in Annex 2. To minimise disturbance to customers and reduce costs, samples may be drawn from “off supply” stock although OPSS recognise that this may not be possible, and samples may have to be taken “off the wall”. Suppliers are free to choose any approved test station with the testing cost a commercial arrangement between the supplier and test station concerned. Suppliers are responsible for this cost although there is no direct cost to the IST participants for OPSS’s governance of the scheme. It is intended that competition between test stations will serve to reduce the meter testing cost.

The test station will perform the tests detailed in Annex 3 and provide the results to the suppliers that have engaged their services, together with details of any excluded or discarded meters. OPSS will provide all approved test stations with suitable test report forms<sup>9</sup> and the test station shall maintain records that can be made available for OPSS audit at any time.

Suppliers shall provide test results to OPSS as soon as possible after they have received them from the test station; and OPSS will assess the acceptability of the meter populations as detailed in the following pages.

Sampled meters (including those classed as Excluded and any Outliers) shall be quarantined by the supplier, as they have the legal responsibility, pending OPSS's decision as to the acceptability of the population. OPSS will notify the supplier in writing when this decision has been made. Suppliers may choose a commercial arrangement to store quarantined meters at the test station used, on the agreement of both parties, if it is more convenient. If there are special circumstances on the part of suppliers to release the meters from quarantine before the decision on the acceptability of the population has been made by OPSS, suppliers are required to seek permission from OPSS beforehand and, if the circumstances are reasonable (which OPSS will assess and make a decision on), be granted permission to release the meters from quarantine.

When the population is deemed acceptable the sampled meters that passed the tests may be placed back in service by the supplier or their appointed agent. Meters that did not pass the tests or were Discarded/Excluded cannot be placed back in service without repair or refurbishment.

**Note 3:**

At OPSS' discretion, a pragmatic approach will be taken regarding the number of meters and populations that should be sampled, in order to, where possible reduce administrative burden to suppliers and subsequently cost to consumers.

---

<sup>9</sup> The test report templates can be requested from OPSS: [electricity.metering@beis.gov.uk](mailto:electricity.metering@beis.gov.uk) or [gas.metering@beis.gov.uk](mailto:gas.metering@beis.gov.uk).

## 8.0 Assessment of results – including criteria

### 8.1 Criteria

The applicable maximum permissible errors (MPE) are given in the tables below:

**For Gas Meters, the MPE under IST test criteria are:**

Flow rate	MPE Class 1.5	MPE Class 1.0 (no additional in service tolerance)
0.2 Q <sub>max</sub>	±3.0%	±1.0%
1.0 Q <sub>max</sub>	±3.0%	±1.0%

Table 3 – Gas meter MPEs, indexed by the accuracy class of the meter

**Note:**

These values are taken from *The Measuring Instruments Regulations (SI 2016/1153)*, as the consequential modifications of the *Gas Act 1986*, of the errors as laid out in Annex IV of the *MID 2014/32/EU*.

**For Electricity Meters, the MPE under IST test criteria are:**

**Single phase and whole current polyphase electricity meters with balanced loads:**

Load point	MPE for meters of Class A	MPE for meters of Class B	MPE for meters of Class C
1 amp @ Unity Power Factor	± 2.5 %	± 1.5%	± 1.0%
20 amps @ Unity Power Factor	± 2.0%	± 1.0%	± 0.5%
I <sub>max</sub> @ Unity Power Factor	± 2.0%	± 1.0%	± 0.5%
I <sub>max</sub> @ 0.5 Inductive Power Factor (Polyphase Meters Only)	± 2.0%	± 1.0%	± 0.5%

Table 4 – Electricity meter MPEs for single phase and balanced load polyphase meters, indexed by the accuracy class of the meter and at the given test points

**Note:**

These values are based on the test requirements in Table 3 of *BS EN 50470-3:2006 +A1:2018* for tests of accuracy at reference conditions, allowing for the additional errors



due to variation of influence conditions to be taken into account. Under IST, the 0.5 Inductive Power Factor load point is only a requirement for polyphase meters.

**Whole current polyphase electricity meters carrying a single-phase load:**

Load point	MPE for meters of Class A	MPE for meters of Class B	MPE for meters of Class C
20 Amps @ Unity Power Factor	± 3.0 %	± 2.0%	± 1.0%
I <sub>max</sub> @ Unity Power Factor	± 3.0 %	± 2.0%	± 1.0%

Table 5 – MPEs for polyphase electricity meters tested with a single-phase loaded, indexed by the accuracy class of the meter and at the given test points

**Note:**

These values are based on the test requirements in Table 4 of *BS EN 50470-3:2006+A1:2018* for tests of accuracy at reference conditions, allowing for the additional errors due to variation of influence conditions to be taken into account. Both load points must be applied to each individual phase. There are no 1 amp test points required for this test as these are not prescribed in the standard.

**8.2 Outliers**

For the assessment detailed in section 8.3, a sample’s average error ( $\bar{x}$ ) and standard deviation (s) should be calculated for each test point and population. As part of this assessment, the effect of any outliers must be evaluated. For this purpose, an outlier is defined as:

- For all the specified loads and flow rates – any test result that indicates more than twice the maximum permitted error<sup>10</sup>.

Regardless of the number of outliers found, only the maximum number of outliers specified below may be removed by OPSS during the evaluation:

Population	Minimum Sample Size	Max No. of Outliers to be Removed
1,201 – 3,200	50	1
3,201 – 10,000	75	2
10,001 – 35,000	100	2
35,001 – 150,000	150	3
>150,000	200	4

Table 6 – Maximum number of meters to be removed, indexed by population and sample size

<sup>10</sup> Australian and New Zealand: AS/NZS 1284.13:2002 Electricity metering – In-service compliance testing.

If a test result were to be defined as an outlier, the meter contributing such a result may be removed from the testing including all other test results from the meter, regardless of whether or not they are also outliers. If a meter contributes more than one test result that would be defined as an outlier, then all test results from this meter will be considered as one outlier.

### 8.3 Assessment method

As explained previously populations may be assessed individually or as part of an overall population and electricity meters may also be assessed as super-populations.

To assess an individual population the sample average error ( $\bar{x}$ ) and the sample standard deviation ( $s$ ) are calculated.

**Determine the value of the following two expressions:**

$$\frac{USL - \bar{x}}{s} \quad \text{AND} \quad \frac{\bar{x} - LSL}{s}$$

**Where:**

$k$  is the acceptability constant<sup>11</sup> for an AQL of 2.5 given in Table 7

$USL$  (the upper specification limit) is the positive tolerance given in 8.1

$LSL$  (the lower specification limit) is the negative tolerance given in 8.1

**Population deemed unacceptable if, for any test point:**

$$\frac{USL - \bar{x}}{s} < k \quad \text{OR} \quad \frac{\bar{x} - LSL}{s} < k$$

**Population deemed acceptable if, for all test points:**

$$\frac{USL - \bar{x}}{s} \geq k \quad \text{AND} \quad \frac{\bar{x} - LSL}{s} \geq k$$

However, see section 8.4 for Overall Population Assessment.

*HISTORICAL INFORMATION ON METER PERFORMANCE SHOULD BE CONSIDERED BEFORE ANY METER POPULATIONS ARE DEEMED UNACCEPTABLE. THIS WILL PROVIDE CONFIDENCE IN THE IST PROCEDURES AND ENSURE THAT ONLY METERS NOT MEETING THE STATUTORY REQUIREMENTS ARE REMOVED FROM SERVICE. ANALYSING HISTORICAL DATA WILL ALSO ENABLE SUPPLIERS AND ASSET OWNERS TO MONITOR THE ONGOING PERFORMANCE OF METERS IN*

---

<sup>11</sup> The value of  $k$  is dependent on the population size (and hence the sample size) and the defined acceptable quality level (AQL). Table II-A – Single sampling plans for normal inspection (master table): “s” method for ISO3951: 1989 has been utilised to derive the appropriate values of  $k$ .

THEIR PORTFOLIOS AND PROVIDE AN EARLY WARNING OF POPULATIONS THAT ARE GETTING CLOSE TO BEING DEEMED UNACCEPTABLE.

HISTORICAL DATA FOR MID GAS METERS WILL NOT BE AVAILABLE UNTIL METERS HAVE BEEN SAMPLED FOR THE SECOND TIME AS THE PERFORMANCE CHARACTERISTICS OF THESE METERS ARE SIGNIFICANTLY DIFFERENT THAN THOSE APPROVED UNDER NATIONAL LEGISLATION.

WHERE A METER POPULATION IS DEEMED UNACCEPTABLE THE POPULATIONS WILL THEREFORE BE RESAMPLED PRIOR TO ANY FINAL DECISION BEING MADE. THIS WILL TAKE PLACE IN THE SAME YEAR AS THE INITIAL SAMPLING AND WILL REQUIRE THE TESTING OF ADDITIONAL METERS – THE SAMPLE SIZE BEING EQUAL TO THAT SAMPLED INITIALLY AS DERIVED FROM TABLE 2.

METERS APPROVED UNDER GB NATIONAL LEGISLATION (“LEGACY”) WILL NOT BE SUBJECT TO RESAMPLING AS HISTORICAL INFORMATION ON METER PERFORMANCE SHOULD ALREADY BE AVAILABLE. HOWEVER, OPSS WILL LISTEN TO REPRESENTATIONS FROM INTERESTED PARTIES BEFORE MAKING A FINAL DECISION ON POPULATION ACCEPTABILITY – SEE SECTION 10, APPEALS PROCESS.

The values for *k*, for the relevant AQLs are shown in the following table (further information on the calculation of AQL’s can be found in Annex 8:

	Sample Size					
	AQL	50 <i>k</i>	75 <i>k</i>	100 <i>k</i>	150 <i>k</i>	200 <i>K</i>
Target	1.00	1.93	1.98	2.00	2.03	2.04
	2.00	1.70	1.74	1.76	1.79	1.79
	2.50	1.61	1.65	1.67	1.70	1.70
	3.00	1.54	1.58	1.59	1.62	1.63
	4.00	1.42	1.46	1.48	1.51	1.51
	5.00	1.32	1.35	1.37	1.40	1.40
	6.00	1.24	1.27	1.29	1.31	1.31
	7.00	1.16	1.20	1.21	1.24	1.24
	8.00	1.10	1.13	1.15	1.17	1.17
Backstop	9.00	1.04	1.07	1.09	1.11	1.11
	10.00	1.00	1.03	1.05	1.07	1.07

Table 7 – The numerical value of the acceptability constant (*k*) indexed by the Acceptable Quality Level (AQL) and sample size

OPSS will also monitor the reports of excluded meters against population type (i.e. sampled meters that are not suitable for testing – see Annex 3). Where the statutory display register or meter construction appears to be deteriorating in an unacceptable

manner then OPSS may request additional samples be taken or specify any particular remedial action.

## 8.4 Overall population assessment

A supplier may choose to maintain its overall portfolio to a specified level of accuracy (e.g. the MEM maintains that 95% of its total portfolio of meters is within the MPE limits). The overall portfolio of a supplier shall be assessed each year from sample results as follows:

- For each individual population of meters tested ( $N_i$ ), calculate the percentage of meters within the MPE ( $P_i$ ) i.e. find the lowest AQL that satisfies the two inequalities given in Section 8.3.
- Multiply the total number of meters in the individual population by the fraction that is within the MPE ( $N_i P_i$ ).
- Calculate this figure for each individual population and sum to find the total number of meters in the overall portfolio that are predicted to be within MPE.
- Divide the total number of meters within MPE by the total portfolio to determine the overall performance measure.

$$Overall = \frac{\sum_{i=1}^n N_i P_i}{\sum_{i=1}^n N_i}$$

Where there are 'n' individual populations and for the  $i^{\text{th}}$  population,  $N_i$  is the total number of meters of that type in the overall portfolio and  $P_i$  is the proportion of meters of that individual type that are estimated from the testing results to perform within the MPE limits.

### Note:

*The following rules shall apply in respect of meters for which test data is limited:*

- *Until a particular meter population is tested for the first time ( $A_1$ ) it will be assumed that 100% are within MPE.*
- *For populations that have been tested once, the fraction within MPE as tested at time  $A_1$  years shall be applied until the meters are next tested.*
- *For populations that have been tested twice, the fraction within MPE as tested at time  $A_2$  will be applied until the meters are next tested*
- *After 3rd testing in year  $A_3$ , estimates based upon a trend line shall be used to estimate performance in intervening years, using all previous test results, e.g.  $A_1$ ,  $A_2$ ,  $A_3$ .*
- *If there are meter types within the portfolio that have been identified under the backstop arrangements below then these shall be excluded from the calculation of the overall population assessment.*

Where a supplier chooses to manage the overall population, action taken as a result of the testing should ensure that the overall percentage of his portfolio estimated to be within MPE never drops below 95%. If less than 95% of the population is estimated to be within

the MPE then urgent action shall be taken to restore the population to the target status within two years.

## 8.5 Backstop arrangements

In order to ensure that poorly performing meters are always removed from the system, any meter types where the sample shows their acceptance AQL is [10%] or higher shall be removed from the system within 2 years. This shall apply under both the individual population assessment and the overall population assessment methods.

*[WHEN DEVELOPING THE IST METHODOLOGY, THE INDUSTRY WAS UNABLE TO AGREE ON THE VALUE OF THE ACCEPTANCE AQL WITH SOME MEMBERS FAVOURING A HIGHER VALUE SO THE METHODOLOGY COULD BE EXTENDED TO LEGACY METERS MORE EASILY. OPSS PROPOSES TO REVISIT THIS WHEN ACTUAL TEST RESULTS AND POPULATION ASSESSMENTS ARE AVAILABLE].*

**Note:**

*That the backstop arrangements shall be applied before the overall population assessment is made. If the overall population assessment is above the required level, taking into account any exclusion made as a result of the backstop arrangement, then no further meter replacements other than those subject to the backstop arrangements shall be required.*

## 9.0 Removal of unacceptable populations

If the assessments above call for a meter population to be replaced then the replacement shall be completed within two years from the decision being taken, subject to reasonable efforts taken to gain access to the consumers' premises. An extension to this period may be granted for large replacement volumes.

**Note:**

*Nothing in this document shall remove the legal obligation to maintain individual meters within the prescribed levels of accuracy. The Regulatory Authority (OPSS) may request additional sampling of any meter population in cases where there is evidence of certain types of 'disputed meters' that are not performing to the required standard.*

## 10.0 Assessment failures (appeals and investigations)

Where a meter type is deemed to have failed IST during its first sample selection assessment, an investigation may be required / requested to ascertain a) the reason for the failure and b) the consistency of the failure across industry participants. Information for the investigation may be obtained from relevant parties (such as manufacturers, asset owners, meter operators, suppliers, industry trade associations etc). Such information shall be considered and, if required, a second sample selection may be utilised to corroborate data obtained from any investigation. OPSS shall review the information obtained from the investigation and any subsequent second sample selection to reach a decision within reasonable timescales.

Information supporting any decision made by OPSS shall be made available for scrutiny (with the exception of commercially sensitive material judged to be exempt from Freedom of Information requests).

**Note:**

*No more than one additional sample selection (i.e. nothing further than a 2<sup>nd</sup> sample selection) shall be utilised to ascertain the current status of the submitted meter type. A meter type failing on a second or subsequent scheduled assessment will not be subject to any repeat testing, but further discussions will continue with all relevant stakeholders and similar processes, using all available data, to ascertain reasons for failure within reasonable timescales.*

OPSS has statutory responsibility for the metrological performance of gas and electricity meters and there will be no formal appeals process for IST once a considered decision has been reached. OPSS will, however, discuss the test results with all relevant parties prior to making any decision.

Any decision made by OPSS will be final.



Office for Product  
Safety & Standards

## **Annexes**

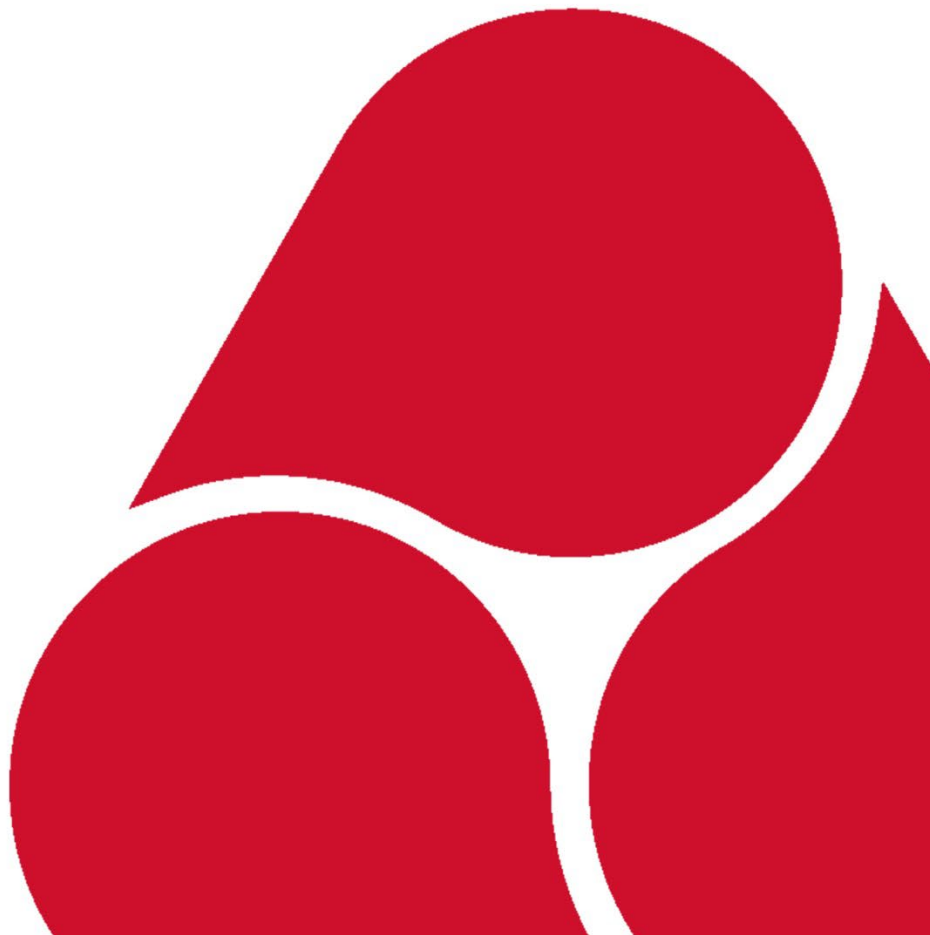



## Annex 1 – Testing timetable

Below is the process timeline for the testing of meters:

Activity	Date
<b>Actions to be conducted in the preceding year</b>	
OPSS will send requests for meter portfolio snapshots to suppliers <sup>12</sup> : <ul style="list-style-type: none"> <li>▪ MID/MIR gas meters</li> <li>▪ MID/MIR electricity meters</li> </ul> NOTE: SUPPLIERS ARE ASKED TO RESPOND AS A GAS/ELECTRICITY SUPPLIER, NOT A MEM or MAP, ETC.	Start of October
Details of meter populations sent to OPSS	By 30 <sup>th</sup> November
Request for sample testing data sent back to suppliers	By 31 <sup>st</sup> December
<b>To be conducted in the calendar year</b>	
Meter testing carried out	1st January – 31 <sup>st</sup> August
Analysis of test results undertaken	1 <sup>st</sup> September – 30 <sup>th</sup> September
Draft Report issued to suppliers	By 31 <sup>st</sup> October
Additional evidence provided by suppliers (if necessary)	By 31 <sup>st</sup> October
Governance Body meeting <sup>13</sup>	During November
Decisions published <sup>14</sup>	End November

Table 8 – IST annual timetable

### Notes:

*For nationally approved meters, IST can be used as a method for determining the overall accuracy of meter populations. OPSS will contact MEMs for gas meters and suppliers for electricity meters where appropriate to enquire on the state of populations currently held, where the population size warrants investigation. This process will be made available until such time as the majority of nationally approved meters have been replaced by MID/MIR approved meters under the smart meter roll-out. See Annex 10.*

<sup>12</sup> Agreed at OPSS-UKMF meeting, April 2012.

<sup>13</sup> The Governance Body shall comprise of representatives of OPSS together with relevant industry stakeholders.

<sup>14</sup> If further analysis is being undertaken for certain meter types, then the report would highlight these meter types and include a statement that suppliers should contact OPSS to confirm the status of any such meters they have in their portfolio.

## IST Flowchart

### Preceding Year

**Start of October:** OPSS contacts suppliers for portfolio snapshot.



**By 30 November:** Details of meter populations sent to OPSS.



**By 31 December:** OPSS determines the required sample size and apportion it between the participants.



### Calendar Year

**1 January – 31 August:** Meter removal and testing carried out at an approved test station and results forwarded to suppliers.

Suppliers submit test results to OPSS as soon as possible and by 1 September at the latest for review.



**1 September – 30 September:** OPSS assesses all test results submitted.



**By 31 October:** Draft report submitted to suppliers and any additional evidence to have been given to OPSS.



Are the results acceptable?

▼ YES

▼ NO

Is historic data available?



▼ YES

▼ NO

Closed discussions take place between all relevant stakeholders to listen to all evidence prior to a decision.

Population resampled during the same calendar year (return to meter removal and testing stage above).



**By 30 November: Decision Published**



**Option A:** Meter can remain in service until the next assessment.

**Option B:** Population must be removed from service within two years.

## Annex 2 – Approved test stations

Test results will only be accepted from organisations formally designated by OPSS for the purpose of IST testing. Appointments will be valid for three years and, to ensure the validity of test results will be subject to audit by OPSS following a clearly defined audit schedule.

### Organisations that will be considered:

- EU Notified bodies approved under the Measuring Instruments Directive for the conformity assessment of gas and electricity meters under Annex B of the Directive.
- UK Approved bodies approved under the Measuring Instruments Regulations (SI 2016/1153, as amended), for the conformity assessment of gas and electricity meters under Schedule 1B.
- Manufacturers and repairers of gas and electricity meters.
- Other organisations with appropriate test equipment, experience, etc.

Organisations wishing to be designated as approved IST stations should contact [gas.metering@beis.gov.uk](mailto:gas.metering@beis.gov.uk) or [electricity.metering@beis.gov.uk](mailto:electricity.metering@beis.gov.uk) as appropriate.

### Test station requirements:

- Appropriate quality procedure in place documenting specifically how IST will be undertaken, how meters are tested and how the process will operate.
- Calibrated test equipment traceable to national standards.
- Appropriately trained staff.
- Dedicated IST provisions, notably goods in and warehouse storage.
- Secure and traceable data storage.
- Controlled testing environment.

### Note:

*The equipment used for IST testing shall have a total uncertainty of measurement of less than or equal to 0.5% for gas meters and 0.4% (at unity power factor) for electricity meters.<sup>15</sup>*

Test measurements made by equipment satisfying the above uncertainty levels shall be deemed to be accurate (i.e. in assessing the population, no allowance shall be made regarding the uncertainty of measurement).

### Note:

*For electricity meters where  $I_{max}$  is not achievable under normal safe operating conditions, as listed under the OPSS approved IST electricity test stations accreditation on page 29, written agreement must be provided from OPSS to allow testing at 0.8  $I_{max}$  for electricity meters up to 120A.*

---

<sup>15</sup> These values represent best practice rather than the normal applicable criteria for measurement accuracy.

The following organisations are currently appointed by OPSS as approved IST test stations:

## Gas

### **SGS United Kingdom Ltd**

Rossmore Business Park  
Ellesmere Port  
Cheshire  
CH65 3EN

Enquiries to: Mike Troughton / Jim  
Kneeshaw

Tel: 0151 350 6654

Email: [Mike.Troughton@sgs.com](mailto:Mike.Troughton@sgs.com) /  
[Jim.Kneeshaw@sgs.com](mailto:Jim.Kneeshaw@sgs.com)

**Accredited to test:**  
Diaphragm and Ultrasonic

---

### **George Wilson Industries Limited**

Unit 2A Longford Industrial Estate  
Bedworth Road  
Coventry  
CV6 6BP

Enquiries to: Gordon Morris

Tel: 02476 709 050

Email: [gordonm@gwi-ltd.co.uk](mailto:gordonm@gwi-ltd.co.uk)

**Accredited to test:**  
Diaphragm and Ultrasonic

## Electricity

### **E.ON**

Meter Test Station  
Unit A  
Moorcroft Park  
Patent Drive  
Wednesbury  
WS10 7XD

Enquiries to: Andrew Sargent

Tel: 07989 397215

Email: [Andrew.sargent@eonenergy.com](mailto:Andrew.sargent@eonenergy.com)

#### **Accredited to test:**

*Single Phase Whole Current, 4 and 5 Terminal,  
Single Phase Whole Current, Twin Element,  
Three Phase Whole Current,  
 $I_{max} = 100A$*

---

### **CL Refurbishments Limited**

118-130  
Bushbury Lane  
Wolverhampton  
WV10 9TW

Enquiries to: Adam Williams

Tel: 01902 604888

Email: [adam@clrefurbs.co.uk](mailto:adam@clrefurbs.co.uk)/  
[production@clrefurbs.co.uk](mailto:production@clrefurbs.co.uk)

#### **Accredited to test:**

*Single Phase Whole Current, 4 and 5 Terminal,  
Single Phase Whole Current, Twin Element,  
Three Phase Whole Current,  
 $I_{max} = 120A$*

---

### **Dragon RS**

Unit 2 Tafarnaubach Industrial Estate,  
Tafarnaubach  
Tredegar  
Blaenau Gwent  
NP22 3AA

Enquiries to: Beth Bysouth

Tel: 01685 840 602 / 0844 335 6758

Email: [enquiries@dragonrs.com](mailto:enquiries@dragonrs.com)

#### **Accredited to test:**

*Single Phase Whole Current, 4 and 5 Terminal,  
 $I_{max} = 120A$   
Three Phase Whole Current,  
 $I_{max} = 100A$*

## Annex 3 – Drawing of samples and test requirements

To minimise the disturbance to customers and to reduce costs, samples may be drawn from “off supply” stock. To ensure that there are sufficient samples suitable for testing, extra samples may be drawn to allow for samples that may be unsuitable for testing. Even when drawn from “off supply” stock, reasonable efforts shall be made to select meters as randomly as possible.

### Discarded / Excluded definitions:

<b>Discarded</b>	The characteristics of a discarded meter will relate to faults that are likely to occur in individual meters and are unlikely to be representative of the whole population. Those deemed to be discarded are not suitable for accuracy testing.
<b>Excluded</b>	The characteristics of an excluded meter will relate to faults that are likely to occur in individual meters that could be related to the population as a whole or an individual batch, in which case the reason for test exclusion will be noted.

The following table determines which meters may be used for assessment:

<b>METER CLASSIFICATION</b>	<b>INCLUDED</b> suitable for accuracy test	<b>DISCARDED</b> unsuitable for accuracy test	<b>EXCLUDED</b> unsuitable for accuracy test: reason is to be recorded
<b>Gas and Electricity Meters</b>			
Normal condition	✓		
Disputed		✓	
Tampered (Physical evidence)		✓	
Missing Security Seals		✓	
Unsafe or Broken Case		✓	
Meter Contaminated (i.e. water)		✓	
Faulty Display			✓
Deteriorated Case <sup>16</sup>			✓
PPM which cannot be enabled for test with a new key or token			✓
<b>Gas Meters</b>			
Advances Under No Load <sup>17</sup>			✓
Passes Un-registered Gas <sup>18</sup>			✓
Fails Gas Tightness			✓
Dents on Case		✓	
<b>Electricity Meters</b>			
Advances Under No Load <sup>17</sup>			✓
Register Advance (Dial) Test <sup>17</sup>			✓
<b>Twin Element Meters</b> – One element is not recording			✓
<b>Three Phase Meters</b> – One (or more) phase(s) is 'open circuit'			✓

Table 9 – List for including, discarding and excluding meters from IST sampling

<sup>16</sup> The level of corrosion on gas meters and its position is to be recorded on the test report sheets as detailed in Annex 4. Only meters deemed to have “High” levels of corrosion are to be excluded from testing. Meters deemed to have “Medium”, “Low” and “None” levels of corrosion are suitable for testing although the information is to be recorded for asset management purposes.

<sup>17</sup> See test requirements.

<sup>18</sup> A meter is deemed to pass unregistered gas if the test drum fails to rotate at least 3 dm<sup>3</sup> in less than 1 hour when air is passed through the meter at 14 dm<sup>3</sup>/h.

The following table should be used to determine whether meters showing error indications or flag operation can be used:

<b>Flag Operation - Ultrasonic Gas Meters to BS EN 14236:2007</b>	<b>INCLUDED</b> suitable for accuracy test	<b>DISCARDED</b> unsuitable for accuracy test	<b>EXCLUDED</b> unsuitable for accuracy test but the reason for exclusion is to be recorded
Unsatisfactory Reading			✓
'A' – catastrophic failure			✓
'b' – event – possible tamper			✓
'C' – operational problem			✓
'd' – and below flag ratings	✓ <sup>19</sup>		
'r' – battery change imminent	✓ <sup>20</sup>		
'F' – battery change overdue	✓ <sup>20</sup>		
<b>Flag Operation - Electricity</b>			
EEPROM Error (may be due to meter interference)			✓
Microprocessor Failure (may be due to meter interference)			✓
Volatile Memory Failure (may be due to meter interference)			✓
Token/Key Communication Failure		✓	
Phase Imbalance	✓		
Power Loss	✓		
Overload		✓	
Default Date and Time	✓		
Battery Low	✓		
Battery Dead	✓ <sup>21</sup>		
Low Voltage	✓		
Signal Failure	✓		

Table 10 – List for including, discarding, and excluding meters from IST sampling

<sup>19</sup> See page 33 “Procedure for sorting of Electronic (E6) meters for IST.

<sup>20</sup> The battery may be changed before accuracy testing.

<sup>21</sup> Electricity meters can be included if, when powered by the bench, they operate. If meters draw too much current and trip the bench then they should be excluded.



***All meters must be sent for testing regardless of their apparent condition when “on the wall” – it is the decision of the test stations whether meters will be included, discarded or excluded. The only exceptions are certain Electronic Index (E6) meters which exhibit particular flags as detailed below.***

***It is advisable that additional meters are sent to the test station to ensure the required number of samples are available should any meters be discarded or excluded. The additional number of samples required may be established by experience.***

### **Procedure for sorting of Electronic Index (E6) Meters for IST**

Where suppliers encounter Electronic meters through “off supply” stock with ‘A’, ‘b’ or ‘C’ flags already present, they are allowed to pre-sort these meters to prevent distorting the results. Records should be made of the number and type of meters which they encounter during the relevant test year in question which are labelled as such, so an asset performance record can be maintained. OPSS reserves the right to request these figures if it is deemed necessary. This will be the only form of pre-sorting allowed by a supplier prior to sending to the test station and meters must still be as randomly sampled as is possible.

Where meters are “taken off the wall” specifically for IST then all meters must be submitted to the test station regardless of flags.

Any meter which has been removed from service or through “off supply” stock which has a ‘d’ Flag or less will still be sent to the test station and a decision made by them as to whether it is possible to still perform accuracy tests. If none can be done, they will be labelled as “excluded” with a reason given.

Suppliers will make a record of the Flag shown (if one exists) before it is sent to the test stations, the test stations will then record the Flag (if any) upon entry, in case it has progressed since it left the supplier/submitter. If the Flag progresses to an ‘A’, ‘b’ or ‘C’, the test station will label the meter as “excluded” and give the reason why.

### **Reporting of excluded meters**

Meters that are classified as ‘excluded’ and deemed unsuitable for the testing process shall not have their accuracy checked but the reason for their exclusion shall be recorded together with the serial number. A report shall be produced which will include the accuracy results for the particular batch indicating the total in each category of exclusion.

OPSS will monitor these results against population type and, where statutory register displays or meter construction appear to be deteriorating in an unacceptable manner, may call for additional samples to be selected for testing or specify particular remedial action.

### **When gas meters are removed from the wall**

SMETS meters are to be deregistered / decommissioned as per manufacturers instruction. The inlet and outlet connections of meters should be sealed immediately after they have been removed from the supply network. Gas meters may be purged with air or inert gas for a short time.

No other processes such as repair, index exchange or flushing with liquid are permitted.

The meters shall be transported and stored carefully. Advice about this should be sought from the manufacturer when dealing with unfamiliar meter types.

The period between the removal of gas meters from the network and the assessment should be as short as possible and ideally should not exceed one month. Where

diaphragm meters have been stored for longer than one month, it must be suitably exercised before testing. Please see “Testing Procedure for Gas Meters” for the current process. Electronic Index (E6) meters do not need any pre-exercising.

### Testing of samples

The testing of the samples shall be carried out by an authorised test station in a controlled manner, as described below:

#### All meters

A visual examination of samples shall be carried out before testing and any meter that cannot be tested for accuracy as part of the sample for the reasons given above shall be discarded or excluded.

### Testing requirements for electricity meters

#### Visual inspection of samples accepted for test

Samples shall be inspected for fitness of purpose following energisation and classified according to Tables 8 and 9. Where meters are to be ‘Excluded’ the reason for exclusion shall be recorded.

Meters showing indications of interference shall be discarded.

#### Testing procedure for electricity meters

##### a) Meter Initialisation / Pre-Heating

A period of 5 minutes (minimum) with the meter voltage circuits energised at  $U_{nom}^{22}$  shall constitute acceptable pre-heating or the ‘Advances Under No Load’ test shall also be acceptable if it is the first test in the overall meter test sequence.

Note: Historically, some meter manufacturers recommended a short period of pre-heating with both voltage and current circuits energised (general calibration principles ‘best practice’) before metrology testing commences. A period of 5 minutes, with  $U_{nom}$  and 20A applied to the meter shall suffice should the Test Facility prefer this method of pre-heating.

##### b) Test Load Points

Meters shall be tested, via the optical or pulsed output, at the following load points: -

#### Whole current single-phase accuracy test load points

Voltage	Current	Phase Angle
230V	$I_{max}$	Unity Power Factor
230V	20 amps	Unity Power Factor
230V	1 amp	Unity Power Factor

Table 11 – Test load points for single-phase Electricity meters

Both elements of a Twin Element Single phase meter shall be tested at the load points shown above.

<sup>22</sup>  $U_{nom}$  = The nominal voltage rating with which the relevant performance of the meter is fixed.

**Whole current polyphase accuracy test load points**

Voltage	Current	Phases Energised	Phase Angle
230V	$I_{max}$	Combined <sup>23</sup>	0.5 Inductive
230V	$I_{max}$	1,2,3 and Combined	Unity Power Factor
230V	20 amps	1,2,3 and Combined	Unity Power Factor
230V	1 amp	Combined	Unity Power Factor

Table 12 – Test load points for polyphase electricity meters

In accordance with the meter manufacturer’s guidelines, each test shall be sufficient in either duration or number of pulses to obtain stable meter errors.

Electro-mechanical meters shall be tested via disc rotation.

All test results shall be recorded to 2 decimal places where possible.

**c) Register Advance Test**

A test shall be conducted whereby the meter error may be calculated from the advance of a total cumulative kWh import register when given a known dosage of energy.

The Register Advance Test is applicable to:

Meters with mechanical registers (Static or Induction)

Meters approved under National Legislation, under consideration for extension (Annex 10)

**Note:**

***The total cumulative kWh display used for the Register Advance Test shall contain a minimum of two decimal places to ascertain the meter error at an acceptable resolution.***

This test shall be undertaken by energising the meter with  $U_{nom}$  at any load point between 20A and  $I_{max}$  at Unity Power Factor.

A minimum dosage of 5 kWh shall be required for single phase meters and 15 kWh for polyphase meters.

A Register Advance Test shall be undertaken on both elements of a Twin Element meter.

Polyphase meters shall be tested with all phases energised.

---

<sup>23</sup> As agreed at the IST 4 Electricity Sub Group meeting on the 24<sup>th</sup> September 2015, with further talks held after the meeting. This power factor is based on the test requirements in Table 4 and 5 of BS EN 50470-3:2006 (since superseded by BS EN 50470-3:2022) for tests of accuracy at reference conditions, allowing for the additional errors due to variation of influence conditions to be taken into account.

The percentage error for the Register Advance Test shall be calculated by:

$$\frac{\text{Actual} - \text{Correct}}{\text{Correct}} \times 100$$

Where:

**Actual:** is the energy (in kWh) recorded by the meter

**Correct:** is the reference energy dosage (in kWh)

Any meter which registers an error greater than the limits of error defined in Tables 4 and 5 (Section 8.1), when tested under the Register Advance Test, shall be deemed 'excluded' and reported in accordance with Annex 3 of the IST Handbook.

**d) No Load Condition Test**

The no load/creep test is a test to ensure that a meter will not advance, when energised by a system voltage without any current. The formula to determine the minimum duration of this test is given by:

$$\Delta t \geq \frac{240 \times 10^3}{k \times m \times U_{test} \times I_{st}} \text{ minutes}$$

Where:

**k** is pulses per kWh of the meter under test (imp/kWh)

**m** is the number of measuring elements

**U<sub>test</sub>** is the test voltage; its value shall be 115% meter U<sub>nom</sub>

**I<sub>st</sub>** is the meter starting current\*

\*Meter starting current (I<sub>st</sub>) is ascertained from the following information:

Transitional Current (I<sub>tr</sub>) is 1/10th of the reference current (I<sub>ref</sub>) shown on the meter information plate. I<sub>st</sub> value is then calculated from:

Accuracy Class	Start Current (I <sub>st</sub> )
<b>A</b>	0.05 I <sub>tr</sub>
<b>B</b>	0.04 I <sub>tr</sub>
<b>C</b>	0.04 I <sub>tr</sub>

Table 13 – Start Current (I<sub>st</sub>) of Electricity meters, given as a ratio of Transitional Current (I<sub>tr</sub>), indexed by the accuracy class of meter

No more than 1 output pulse shall be allowed.

Any meter that fails this test shall be deemed 'excluded' and reported in accordance with Annex 3 of the IST Handbook.

## Testing requirements for gas meters

Initial testing of gas meters

### Passing of Unregistered Gas (PUG) (for Diaphragm meters only)

Paragraph 3(1)b(ii) of [The Gas \(Meters\) Regulations 1983 \(No. 684\)](#) may also be considered with respect to internal leakages, whereby the meter is connected and tested by passing air through it at a specified inlet pressure and designated flow rate so as to operate the test dial through at least one revolution. As an informative basis for determining the test required to demonstrate the criteria for the Passing of Unregistered Gas (PUG), the following may apply:

The meter shall be acclimatised for a 24-hour period and then tested for leakage at the ambient temperature. The meter shall register when air is passed through it at a suitably defined flow rate for a minimum of one working cycle of the measuring unit. During this test the test drum shall move proportionally by a fixed amount of volume under one hour.

As an example, when conducting the test for assessing the meter, a 15-minute test at 14 dm<sup>3</sup>/h would result in an expected volume of 3.5 dm<sup>3</sup>/h ± 0.75 dm<sup>3</sup>/h. The limits being applied after 15 minutes at 14 dm<sup>3</sup>/h should result in a minimum volume of 2.8 dm<sup>3</sup>/h and maximum of 4.2 dm<sup>3</sup>/h which the meter is allowed to pass.

#### Note:

The above example is based on the test method specified under [BS 4161-3:1989](#), which was withdrawn and superseded by the [BS EN 1359:1999](#) standard and subsequently [BS EN 1359:2017](#) – Diaphragm gas meters.

Test stations may apply an alternative PUG test which is appropriate for the gas meter under test, and the test applied does not have to be identical to the example above. OPSS are available to review any proposed test methods.

### Gas Tightness (External Leakage)

Based upon the requirements of the IGEM UP/1B Edition 3

After a period of acclimatisation, the outlets of the sample meters are connected to the pressure gauge and their inlets to an air supply. The meter is filled with air at a pressure of 20 to 21 millibars (mbar) or any other equivalent value deemed to be appropriate. The inlet of the meter is isolated and a further acclimatisation of 1 minute will take place at this pressure, should any drop occur during this time, the pressure can be increased back up to 20 to 21 mbar and the test will then commence immediately. The inlet of the meter is isolated again if needed after any refill and the pressure shall be recorded and monitored for any external leakage for a period of at least two minutes. Any drop measured will result in the meter classed as excluded as per Table 8 with the reason recorded.

### Advances Under No Load (For Electronic Index (E6) meters only)

The Advance Under No Load test will only consider the external (i.e. visible) register when determining whether the meter has advanced.

The meter will be suitably capped and sealed and left for a minimum of one hour at standard operating temperature of the test station to allow it to stabilise. After that time the register will be recorded, and the meter left for **Seven (7)** days and the register recorded

again at the end of this period. If it has moved by one litre in that period (the last visible digit of the external register) it will be classed as Advancing Under No Load and the meter classed as “excluded” as per Table 8 with the reason recorded.

Suppliers are permitted to ask the test station to record the internal register before and after, if the test station has the capabilities to analyse the meter in that way, should they wish for asset management purposes.

### **Testing procedure for gas meters**

For diaphragm meters, before starting the tests, a volume of air equal to at least one hundred (100) times the cyclic volume of the meter shall be passed through the meter. IST test stations can determine the exact nature of this exercising depending on the test equipment available but 100 or 200 litres at half  $Q_{max}$  is felt adequate.

The accuracy of the gas meter shall be tested once at each of the following flow rates:

0.2  $Q_{max}$  and 1.0  $Q_{max}$

All test results shall be recorded to 2 decimal places where possible.

### **Test results**

OPSS will combine the test results provided by contributing suppliers and analyse the performance of each population type in accordance with the procedure detailed in Section 8.

## Annex 4 – Rust / corrosion guide for gas meter cases

The following photographs are to be used as a guide for determining the level of any corrosion of gas meters submitted for testing. When the meters are inspected prior to any possible commencement of testing, the testers should grade each case for the extent of any corrosion. An example of a meter with zero corrosion has also been included as a guide, which will be labelled as N/A on the test report. Where corrosion/rust is found, the location(s) on the meter needs to be recorded, using the list below for positions and the level of corrosion stated as per the statements below. Where any part of the meter is classified with a “High” level of corrosion/rust, that meter will be EXCLUDED as per Table 8, with the reason recorded. Meters with zero, low or medium levels of corrosion can be included in the accuracy tests.

- 1 – Boss**
- 2 – Band**
- 3 – Body**

The statements below will help in establishing what each level corresponds to.

### High

Heavy rust/corrosion is evident that appears to be causing localised and or general corrosion and is likely to pose a safety issue in the short term. The metal has multiple signs of being ‘eaten’ away. These meters are to be EXCLUDED – i.e. unsuitable for the accuracy test with the level and position of the corrosion recorded on the test report format.

### Medium

Rust/corrosion is evident but is unlikely to be at a point where localised/general corrosion is likely to pose a safety issue in the medium term. Evidence of metal being ‘eaten’ away is detected but is not considered to be ‘High’. These meters are to be INCLUDED – i.e. suitable for the accuracy test with the level and position of the corrosion recorded on the test report for asset management purposes only.

### Low

Evidence of surface rust only. This will normally be indicated by light / dark brown deposits only with no apparent ‘eating’ away of the metal. These meters are to be INCLUDED – i.e. suitable for the accuracy test with the level and position of the corrosion recorded on the test report for asset management purposes only.

### None

No clear evidence of any rust is visible.

### N/A

A gas meter is deemed to have an obscured band, i.e. no corrosion level may be obtained.

**None – Corrosion / rust on meter**



*Gas meter – No rust over meter body*



*Gas meter – No rust over meter band*



*Gas meter – No rust over meter boss*



## High – Rust on meter body



*Gas meter – High level of rust on body*

## High – Rust on meter boss



*Gas meter – High level of rust on boss*

## Medium – Rust on meter band



*Gas meter – Medium level of rust on band*

## Medium – Rust on meter boss



*Gas meter – Medium level of rust on boss*



**Low – Rust on meter body**



*Gas meter – Low level of rust on body*

**Low – Rust on meter boss**



*Gas meter – Low level of rust on boss*

## Annex 5 – Electricity meter testing example

### Whole current Single-Phase example

Sample Meter: Single Phase  
 Class B accuracy  
 230V, 1-20 (100)A,  
 1000 imp / kWh  
 2 decimal place cumulative kWh test display

#### Meter Initialisation / Pre-Heat

Undertake 'No load' test first in test sequence or energise at 230V, 20A for a minimum of 5 minutes.

#### Meter accuracy error results

Voltage	Current	Phase Angle	Meter Error
230V	$I_{max}$	Unity Power Factor	+0.26%
230V	20 amps	Unity Power Factor	+0.45%
230V	1 amp	Unity Power Factor	+1.07%

Table 14 – Example error results of single-phase meter

#### Register Advance Test

5 kWh is applied for a single-phase meter.

Actual advance = 5.02 kWh

Correct advance should be 5.00 kWh

$$\begin{aligned}
 \text{Register \% error} &= \frac{\text{Actual} - \text{Correct}}{\text{Correct}} \times 100 \\
 &= \frac{5.02 - 5.00}{5.00} \times 100 \\
 &= +0.40\%
 \end{aligned}$$

#### No Load Condition Test

Ascertain  $I_{st}$ :

$$I_{tr} = 1/10 \times 20A = 2A$$

$$I_{st} = 0.04 \times 2A = 80mA$$

No load test duration:

$$\Delta t \geq \frac{240 \times 10^3}{k \times m \times U_{test} \times I_{st}} \text{ minutes}$$

$$\geq \frac{240 \times 1000}{1000 \times 1 \times (230 \times 1.15) \times 0.08} \text{ minutes}$$

$\Delta t \geq 11.34 \text{ minutes}$

Meter passes if no more than 1 impulse is detected within the calculated time period.

### Whole current polyphase example

#### Meter accuracy error results

Voltage	Current	Phase(s) Energised	Phase Angle	Meter Error
230V	I <sub>max</sub>	All Phases Combined	Unity Power Factor	+1.40%
230V	I <sub>max</sub>	All Phases Combined	0.5 Inductive	+0.90%
230V	I <sub>max</sub>	Phase 1	Unity Power Factor	+1.80%
230V	I <sub>max</sub>	Phase 2	Unity Power Factor	+1.60%
230V	I <sub>max</sub>	Phase 3	Unity Power Factor	+1.90%
230V	20 amps	All phases Combined	Unity Power Factor	+0.95%
230V	20 amps	Phase 1	Unity Power Factor	-1.30%
230V	20 amps	Phase 2	Unity Power Factor	-1.10%
230V	20 amps	Phase 3	Unity Power Factor	-1.90%
230V	1 amp	All Phases Combined	Unity Power Factor	+0.97%

Table 15 – Error readings of example poly-phase meter

#### Polyphase Register Advance Test

15 kWh is applied for a polyphase meter.

Actual advance = 15.02 kWh

Correct advance should be 15.00 kWh

$$\begin{aligned} \text{Register \% error} &= \frac{\text{Actual} - \text{Correct}}{\text{Correct}} \times 100 \\ &= \frac{15.02 - 15.00}{15.00} \times 100 \\ &= +0.13\% \end{aligned}$$

## Annex 6 – Worked example

### Gas meter worked example

Population of meter type is deemed to be, between **1,201** and **3,200**. A sample of **50** meters shall be sent for testing. Meter is of an **accuracy class of 1.5** therefore an **MPE of ±3.0%**. For a sample of 50 meters, using the **AQL of 2.5** we have a **k value of 1.61**. (See 8.3, table 7)

#### Test Data

Serial number	0.2 Q <sub>max</sub>	Q <sub>max</sub>	Serial number	0.2 Q <sub>max</sub>	Q <sub>max</sub>
S/N 1	-1.39	-0.84	S/N 27	0.75	-0.40
S/N 2	-1.63	-1.53	S/N 28	-0.96	1.62
S/N 3	-0.63	-0.12	S/N 29	0.07	0.18
S/N 4	0.21	0.18	S/N 30	-1.11	-0.84
S/N 5	1.04	0.15	S/N 31	-0.20	0.23
S/N 6	0.68	0.66	S/N 32	2.99	-0.67
S/N 7	0.21	-0.37	S/N 33	2.21	0.82
S/N 8	-0.95	-2.91	S/N 34	1.56	-0.37
S/N 9	0.71	-1.73	S/N 35	-1.41	-0.19
S/N 10	1.86	0.82	S/N 36	0.31	0.86
S/N 11	-1.93	-1.69	S/N 37	-1.23	-0.58
S/N 12	1.54	0.74	S/N 38	-0.38	-0.20
S/N 13	2.94	1.36	S/N 39	-0.92	0.57
S/N 14	0.08	-1.92	S/N 40	-0.55	-0.21
S/N 15	-0.50	-1.48	S/N 41	-1.34	-1.96
S/N 16	0.28	-1.13	S/N 42	0.10	-1.54
S/N 17	-0.21	-1.52	S/N 43	2.66	1.12
S/N 18	1.53	1.20	S/N 44	-0.98	-0.98
S/N 19	-0.61	-0.43	S/N 45	-0.19	0.93
S/N 20	-2.56	-2.44	S/N 46	1.84	0.90
S/N 21	0.78	-1.19	S/N 47	-0.17	0.54
S/N 22	-1.14	-1.21	S/N 48	1.23	0.86
S/N 23	-0.57	-0.60	S/N 49	0.44	-0.11
S/N 24	1.09	0.26	S/N 50	-0.58	-0.65
S/N 25	0.74	0.25	<b>Average/Mean <math>\bar{x}</math></b>	<b>0.1352</b>	<b>-0.3098</b>
S/N 26	1.05	0.07	<b>Standard Deviation s</b>	<b>1.271922</b>	<b>1.055765</b>

**Equation for calculating acceptable population quality**

$$\frac{USL - \bar{x}}{s} \geq k \quad \text{and} \quad \frac{\bar{x} - LSL}{s} \geq k$$

**USL** Upper Specification Limit

**LSL** Lower Specification Limit

$\bar{x}$  Average Sample Error

**s** Sample Standard Deviation

**k** Acceptability Constant

**Example using the Upper Specification Limit at 0.2Q<sub>max</sub>**

1. First calculate  $\bar{x}$ , the Average Sample Error, in this instance it is 0.1352
2. Then calculate **s**, the Sample Standard Deviation, in this instance it is 1.271922

3. Now work through the equation:  $\frac{USL - \bar{x}}{s}$

$$USL = 3.0\% \quad \bar{x} = 0.1352 \quad s = 1.271922$$

$$\frac{3.0 - 0.1352}{1.271922} = \frac{2.8648}{1.271922} = \mathbf{2.25}$$

4. Place the value into the equality and estimate if it is **greater than or equal to k**
5. **2.25** is  $\geq 1.61$  therefore the population passes this part of the assessment, this must now be repeated for the **LSL**

**Example using the Lower Specification Limit at 0.2Q<sub>max</sub>**

1. First calculate  $\bar{x}$ , the Average Sample Error, in this instance it is 0.1352
2. Then calculate **s**, the Sample Standard Deviation, in this instance it is 1.271922

3. Now work through the equation:  $\frac{\bar{x} - LSL}{s}$

$$LSL = -3.0\% \quad \bar{x} = 0.1352 \quad s = 1.271922$$

$$\frac{0.1352 - -3.0}{1.271922} = \frac{3.1352}{1.271922} = \mathbf{2.47}$$

4. Place the value into the equality and check that it is **greater than or equal to k**
5. **2.47** is  $\geq 1.61$  therefore the population passes this part of the assessment, and the population has successfully passed at 0.2Q<sub>max</sub>.
6. Repeat for Q<sub>max</sub>, if **all** values are  $\geq k$  then the population **passes** IST.
7. If either value, at either flow rate (or any load point for electricity) is less than **k**, the population shall be deemed **unacceptable**.

## Annex 7 – Calculation of AQL values

The tables and graph below indicate the mechanism to calculate  $k$  values for different AQLs and for different sample sizes.

The value of  $k$  is dependent on the population size (and hence the sample size) and the defined acceptable quality level (AQL). The values shown below as “Actual  $k$ ” have been drawn from Table II-A – Single sampling plans for normal inspection (master table): “s” method for **BS 6002-1:1993, ISO 3951:1989**. The values shown as “Predicted  $k$ ” have been calculated from a curve fitting the equation that shows a good fit to the Standard values.

$k$  can be predicted from the equation:

$$y = \frac{(a + c \ln x)}{(1 + b \ln x)}$$



For:

**Sample Size = 50**

**a = 1.942**  
**b = -0.082**  
**c = -0.495**

Graph 1 – Actual & Predicted k value against Acceptable Quality Level (AQL) for a sample size of 50

AQL	Actual k	Predicted k
0.10	2.60	2.59
0.15	2.50	2.49
0.25	2.35	2.36
0.40	2.22	2.23
0.65	2.08	2.08
1.00	1.93	1.94
1.50	1.80	1.80
2.00	N/A	1.70
2.50	1.61	1.61
3.00	N/A	1.54
4.00	1.42	1.42
5.00	N/A	1.32
6.00	N/A	1.24
6.50	1.21	1.20
7.00	N/A	1.16
8.00	N/A	1.10
9.00	N/A	1.04
10.00	1.00	0.99

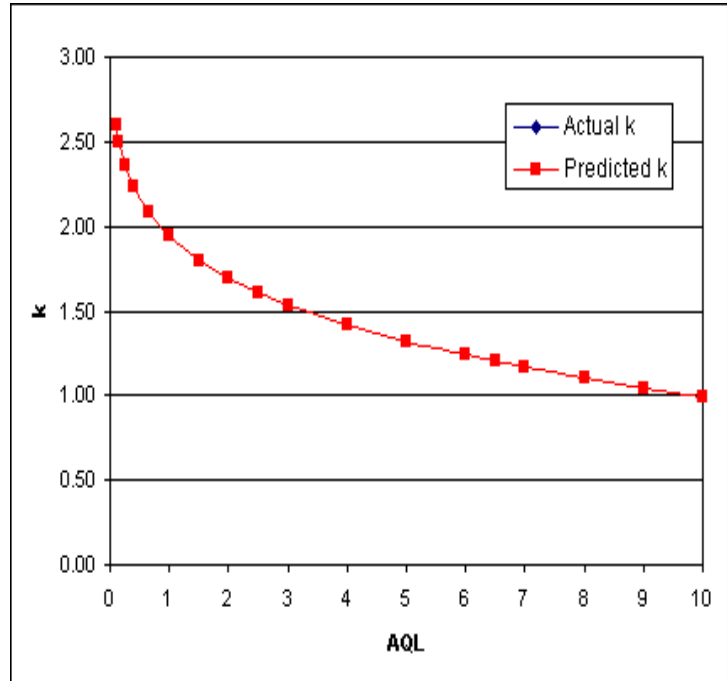

**Sample Size = 75**

**a = 1.988**  
**b = -0.083**  
**c = -0.506**

Graph 2 – Actual & Predicted k value against Acceptable Quality Level (AQL) for a sample size of 75

AQL	Actual k	Predicted k
0.10	2.66	2.65
0.15	2.55	2.55
0.25	2.41	2.41
0.40	2.27	2.28
0.65	2.12	2.13
1.00	1.98	1.99
1.50	1.84	1.84
2.00	N/A	1.74
2.50	1.65	1.65
3.00	N/A	1.58
4.00	1.46	1.45
5.00	N/A	1.35
6.00	N/A	1.27
6.50	1.24	1.23
7.00	N/A	1.20
8.00	N/A	1.13
9.00	N/A	1.07
10.00	1.03	1.02

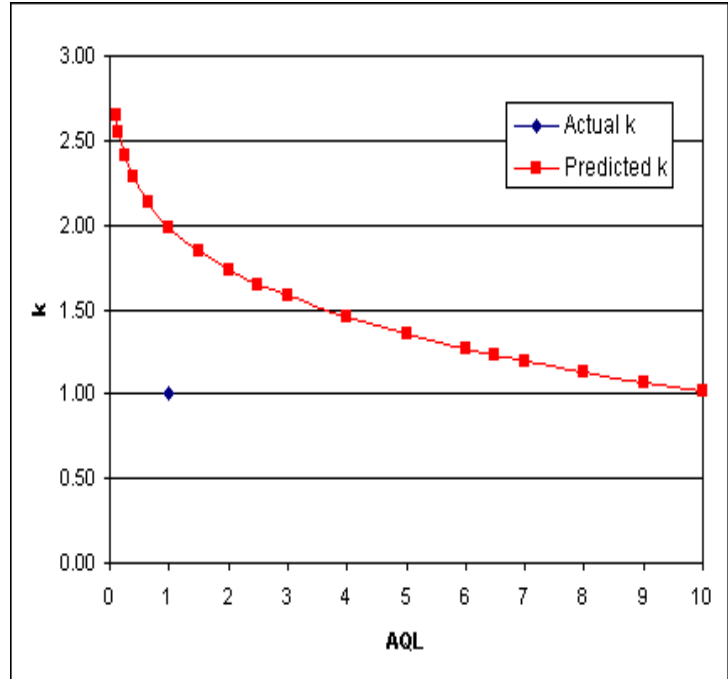

**Sample Size = 100**

**a = 2.010**  
**b = -0.083**  
**c = -0.511**

Graph 3 – Actual & Predicted k value against Acceptable Quality Level (AQL) for a sample size of 100

AQL	Actual k	Predicted k
0.10	2.69	2.68
0.15	2.58	2.57
0.25	2.43	2.44
0.40	2.29	2.30
0.65	2.14	2.15
1.00	2.00	2.01
1.50	1.86	1.87
2.00	N/A	1.76
2.50	1.67	1.67
3.00	N/A	1.59
4.00	1.48	1.47
5.00	N/A	1.37
6.00	N/A	1.29
6.50	1.26	1.25
7.00	N/A	1.21
8.00	N/A	1.15
9.00	N/A	1.09
10.00	1.05	1.03

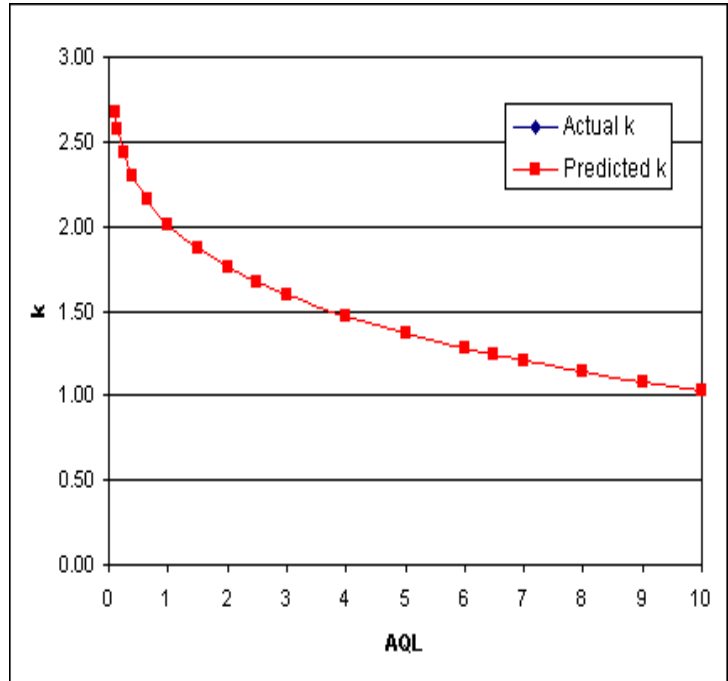

**Sample Size = 150**

**a = 2.044**  
**b = -0.085**  
**c = -0.520**

Graph 4 – Actual & Predicted k value against Acceptable Quality Level (AQL) for a sample size of 150

AQL	Actual k	Predicted k
0.10	2.73	2.71
0.15	2.61	2.61
0.25	2.47	2.47
0.40	2.33	2.34
0.65	2.18	2.19
1.00	2.03	2.04
1.50	1.89	1.90
2.00	N/A	1.79
2.50	1.70	1.70
3.00	N/A	1.62
4.00	1.51	1.50
5.00	N/A	1.40
6.00	N/A	1.31
6.50	1.29	1.27
7.00	N/A	1.24
8.00	N/A	1.17
9.00	N/A	1.11
10.00	1.07	1.05

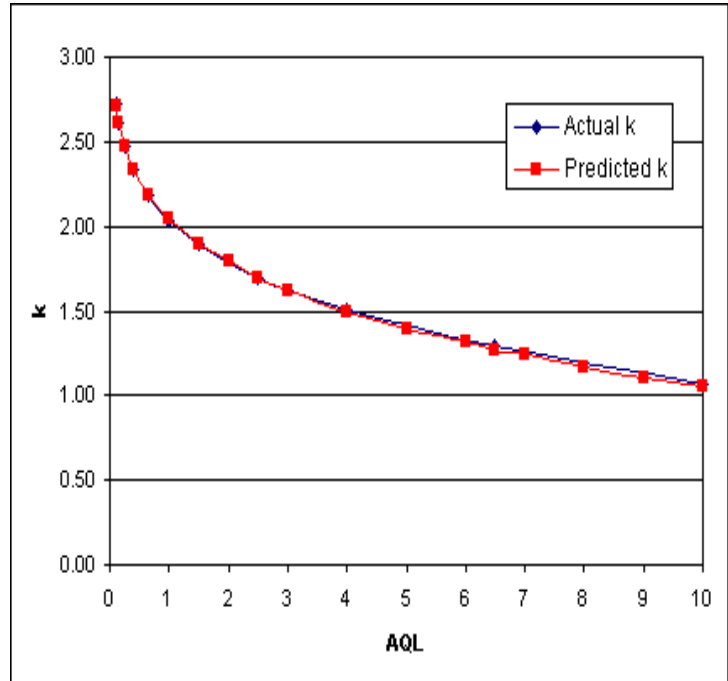

**Sample Size = 200**

**a = 2.046**  
**b = -0.085**  
**c = -0.520**

Graph 5 – Actual & Predicted k value against Acceptable Quality Level (AQL) for a sample size of 200

AQL	Actual k	Predicted k
0.10	2.73	2.71
0.15	2.62	2.61
0.25	2.47	2.48
0.40	2.33	2.34
0.65	2.18	2.19
1.00	2.04	2.05
1.50	1.89	1.90
2.00	N/A	1.79
2.50	1.70	1.70
3.00	N/A	1.63
4.00	1.51	1.50
5.00	N/A	1.40
6.00	N/A	1.31
6.50	1.29	1.28
7.00	N/A	1.24
8.00	N/A	1.17
9.00	N/A	1.11
10.00	1.07	1.06

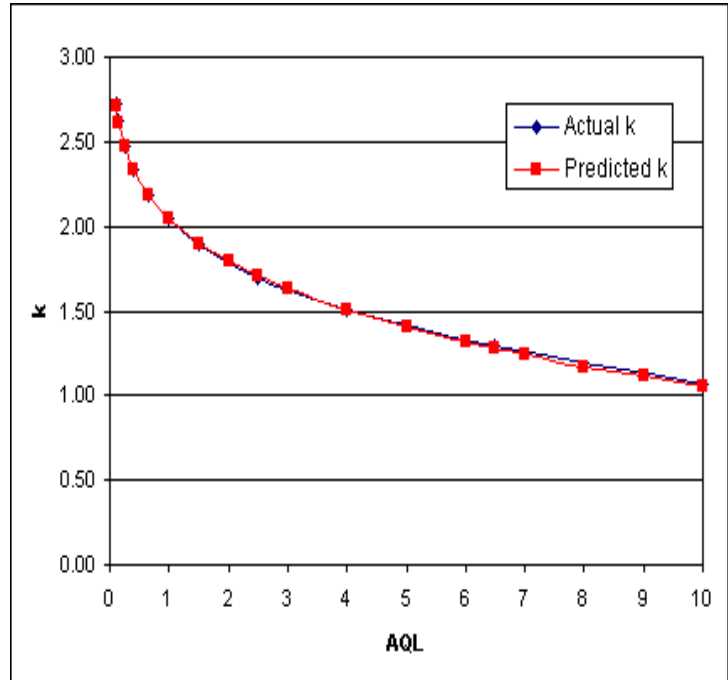

## Annex 8 – Treatment of electricity meter super-populations assessed individually

Tests on meters of the first year's production  $Y$  of a super-population (as defined in 5.4) dictate what happens to all meters in that super population, subject to the safeguards below.

If the tests in year  $Y+A_1$  are satisfactory (for explanation of  $A_1$  etc see section 6.0 and for population acceptance criteria see section 8.3) then no further tests are carried out until year  $Y+A_2$ , when that year's population is tested again. Meters produced in years  $Y+1$ ,  $Y+2$ ,  $Y+3$ , etc are deemed to meet requirements until the next tests.

### Annex 8.1 Safeguards

For assurance in this process, it is important that:

- the super-population comprises meters having consistent metrological properties (see section 5.4);
- the first year's production is of sufficient volume to be representative of the yearly populations to follow; and
- the sample size (as indicated in Table 2) is related to the *total super population* – not the population of the year(s) tested.

With respect to the second point, a population below the threshold as indicated in Table 2 (i.e. less than 1,201) would not be considered satisfactory and testing should be deferred until year  $Y+A_1+1$ . Where the population exceeds 1,201 but is less than [30%] of the next year's population, testing may be done in year  $Y+A_1$ . In both cases samples should be taken from both years  $Y$  and  $Y + 1$  to make up the sample size as dictated by the total super population. Where the first year's population is greater than [30%] of the next year's population, then samples may be drawn from year  $Y$  only.

*[WHEN DEVELOPING THE IST METHODOLOGY, THE INDUSTRY WAS UNABLE TO AGREE ON THIS PERCENTAGE. OPSS PROPOSE TO REVISIT THIS WHEN ACTUAL TEST RESULTS ARE AVAILABLE].*

### Annex 8.2 Removal of defective meters

If the tests in any year  $Y+A_x$  do not meet the acceptance criteria of an AQL of 2.5% but the actual AQL is less than 10%, then the meters produced in year  $Y$  shall be removed within 2 years. Meters produced in year  $Y+1$  shall be removed within 2 years from year  $Y+A_x+1$ , meters of year  $Y+2$  within 2 years of year  $Y+A_x +2$ , and so on.

If the results of the tests indicate an AQL of 10% or greater, then the entire super-population shall be removed within 2 years of year  $Y+A_x$

#### Note:

*In the event that this causes logistical problems additional testing may be carried out on meters produced in other years which may confirm the need for such action or indicate that additional time for removal could be justified*

## Annex 9 – Measuring Instruments Directive (MID)

The Measuring Instruments Directive (MID) is a European Directive (2004/22/EC), originally implemented in 2006 and recast in February 2014 (2014/32/EU), that covers a number of different measuring instrument types including gas meters and active electrical energy meters. The aim of the MID is to create a single market in measuring instruments for the benefit of manufacturers and, ultimately, consumers across Europe:

[https://ec.europa.eu/growth/single-market/european-standards/harmonised-standards/measuring-instruments\\_en](https://ec.europa.eu/growth/single-market/european-standards/harmonised-standards/measuring-instruments_en)

In the UK, the MID for gas and electricity meters was implemented by The Measuring Instruments Regulations (MIR) (SI 2016/1153).

From 1 January 2021 all new meter designs/types must be approved against the requirements of the MIR, as amended by the **Product Safety & Metrology etc. (Amendment etc.) (EU Exit) Regulations (SI 2019/696)** and have the UKCA (UK Conformity Assessed) mark placed on them to indicate conformance to the MIR.

There is a four-year transition period, where current CE marked meters can continue to be placed on the market within GB until the 31st of December 2024. On 1st August 2023, the UK government announced the intention to extend recognition of the CE marking for placing on the market in GB indefinitely, i.e. beyond the 4 year Transition Period.

The MIR is available to download from [www.legislation.gov.uk](http://www.legislation.gov.uk).

The original MID implementing regulations<sup>24</sup> came fully into force on 30 October 2006, while the regulations listed above, to implement the recast MID, came fully into force on 28 December 2016. Since 30 October 2006, all new designs of gas and electricity meters that are within the scope of the Directive must meet the requirements of the regulations.

### **Note:**

*Any meter approved under national legislation and placed on the market prior to 30 October 2016, after the 10-year transition period from implementing the MID into UK law, may continue to be used indefinitely, as long as it meets the requirements of the regulations.*

---

<sup>24</sup> The Measuring Instruments (Gas Meters) Regulations (SI 2006/2647) and The Measuring Instruments (Active Electrical Energy Meters) (SI 2006/1679).

## Annex 10 – Testing of nationally approved electricity meters for extending certification period

Schedule 7 of the **Electricity Act 1989** (as amended) requires suppliers to ensure their meters are kept in proper order at all times and that all meters are certified unless used in connection with an exempt supply<sup>25</sup> where the supplier and consumer have agreed in writing to dispense with the requirement. Where certification is required, it is an offence for an authorised supplier to supply electricity through a meter which is not certified.

Certification is the process whereby it is confirmed meters conform to the relevant standards, and meters can reasonably be expected to operate within the permitted margins of error for not less than the certification period.

Meters approved under GB national legislation have a statutory certification life which is the maximum number of years the meter may legally remain in service. Certification periods are specified in Schedule 4 of The Meters (Certification) Regulations (SI 1998/1566), (as amended) which is published on the OPSS website at:

<https://www.gov.uk/government/publications/schedule-4-uk-nationally-approved-electricity-meters>

Certification periods are set by Meter Examiners appointed by OPSS and have historically been controlled via the National Sample Survey (NSS) organised by the UKMF. Following discussions with the UKMF it was agreed IST could be used as an alternative to the NSS to control the certification periods of meters approved under national legislation.

Extensions to certification periods of up to 5 years per meter type will be considered for meter populations that meet the criteria set in this handbook.

IST has been used by several suppliers to extend the certification periods of a number of meter types in their portfolios. This enables suppliers to fulfil their legal obligations and maximise asset life, while ensuring only meters operating within the statutory limits are used for billing consumers.

Authorised suppliers wishing to apply for an extension to the certification period of a particular meter type should first contact OPSS and confirm the Manufacturer, Meter Type, Approval Number and current Certification period as listed under Schedule 4.

### Sample size and criteria for testing

Acceptable sample sizes must be provided according to Table 2 in Section 7. Certification periods apply nationally and, as the national population is generally unknown, the minimum sample size required is 200 meters.

Subject to agreement with OPSS, samples submitted for testing should comprise of meters with the same type and following the previously adopted procedures that:

---

<sup>25</sup> An exempt supply, as defined in Schedule 7 of the Electricity Act 1989, is a supply of electricity to any premises not used wholly or mainly for domestic purposes.



- Single and twin element variants need to be sampled separately
- Single and multi-rate variants need to be sampled separately for electro-mechanical meters (or meters with mechanical registers)
- Single and multi-rate variants can be combined for electronic meters

Sample testing normally takes place at 5-year intervals and OPSS will not normally consider further testing within this period.

Samples submitted for testing must be predominantly from the particular year being considered although OPSS will accept meters from two years either side of this (e.g. meters from 2000,01,02,03 and 04 with the majority of meters from 2002).

For meters certified before 1990 samples are required from at least three MPAN's/locations. This is because pre 1990 meters were certified at the meter test stations to the limits that were in force at that time (i.e. +2.5% to -3.5%). In contrast post-1990 meters were generally certified at one location (i.e. the manufacturers premises) in accordance with an approved sampling plan to  $\pm 1.9\%$ .

For this reason, populations of pre 1990 meters are not considered to be homogenous and, as with the NSS, only in extreme circumstances and with the written agreement of OPSS, can samples be selected from one or two locations.

Samples may be drawn from "off supply" meters although OPSS recognise this may not be possible and samples may have to be taken "off the wall".

Suppliers should ensure meters submitted for testing are representative of the installed population and do not have faulty displays, missing security seals or damaged cases, etc. Disputed meters or those showing evidence of tamper are also not suitable for sampling (see Annex 3).

Testing must take place at one or more of the official OPSS approved IST test stations, as listed in Annex 2.

## **Analysis of test results**

Suppliers must provide OPSS with the test results for evaluation in accordance with Section 7. OPSS will analyse the performance of each population type in accordance with the procedure detailed in Section 8.

OPSS will consider extending the certification period by a maximum of five years for meter types that achieve an Acceptable Quality Level of 2.5% (or better) at all test loads.

The certification period will not be extended for meter types that do not achieve an Acceptable Quality Level of 2.5% at all test loads.

OPSS reserve the right to reduce the certification period for any meter types where the Acceptable Quality Level is 10% (or worse) at any test load or where there are other concerns about the conformity of the meters.

Certification is a legal requirement and, where the test results do not justify the extension to the certification period of a particular meter type (or the certification period is reduced) these meters must be removed as soon as possible in accordance with Section 9. See also the comment in section 8.3 with regards to meters approved under GB national legislation.

## **Assessment failures**

Where the IST process is used for testing nationally approved meters, OPSS will listen to any appeals on an individual basis and will consider evidence that may be produced by meter manufacturers, asset owners, suppliers, etc. Further sampling may be permitted should a supplier or asset owner feel the test results are not indicative of their meter population as a whole or should they be able to provide reasonable grounds as to why re-testing may be warranted, but this would only be undertaken as a last resort where no historical sampling records exist, and overwhelming evidence points to further sampling being necessary in assessing the population correctly.

## Annex 11 – Reference documents

The following documents have been used in the preparation of this guide:

- A. The Measuring Instruments Directive (MID) [2014/32/EU](#)
- B. The Measuring Instruments Regulations, 2016 – ([SI 2016/1153](#))
- C. The Product Safety & Metrology etc. (Amendment etc.) (EU Exit) Regulations ([SI 2019/696](#))
- D. AS/NZS 1284.13:2002 – Electricity metering – In service compliance testing
- E. [BS 6002-1:1993, ISO 3951:1989](#) – Sampling Procedures for Inspection by Variables<sup>26</sup>
- F. [BS EN 50470-3:2006+A1:2018](#) – Electricity metering equipment (a.c.) – Part 3: Particular requirements – Static meters for active energy (class indexes A, B and C)
- G. BS EN 14236:2007 – Ultrasonic domestic gas meters
- H. BS 4161-3:1989 – Part 3: Specifications for Diaphragm Meters of 6 Cubic Metres (or 212 Cubic Feet) Per Hour Rating for Working Pressures up to 50 mbar<sup>27</sup>
- I. The Gas (Meters) Regulations, 1983 – SI 1983/684
- J. The [Gas Act 1986](#)
- K. The [Electricity Act 1989](#)
- L. The Meters (Certification) Regulations, 1998 – SI 1998/1566
- M. IGEM UP/1B Edition 3, Communication 1759 – Tightness testing and direct purging of small Liquefied Petroleum Gas/Air, Natural Gas and Liquefied Petroleum Gas installations
- N. WELMEC 4.2 – Issue 1, June 2006: Elements for deciding the appropriate level of confidence in regulated measurements (Accuracy classes, MPE in service, non-conformity, principles of uncertainty) - <https://www.welmec.org/welmec/documents/guides/4.2/4-2.pdf>
- O. Committee Draft (CD 2) for a Document of OIML drawn up within TC 3/SC 4 December 2005 Surveillance of utility meters in service on the basis of sampling inspections – <http://www.oiml.org/en/technical-work/committee-drafts/files/tc3-sc4-2cd.pdf>
- P. Industry Metering Advisory Group In service Testing Report (IST 1/2 report) – <https://www.gov.uk/government/publications/in-service-testing-group-1-and-2-report>
- Q. In service Testing Governance Arrangements (IST 3 report) – <https://www.gov.uk/government/publications/in-service-testing-group-3-report>

---

<sup>26</sup> This document has since been superseded by “ISO 3951-1:2022 – Sampling procedures for inspection by variables. Specification for single sampling plans indexed by acceptance quality limit (AQL) for lot-by-lot inspection for a single quality characteristic and a single AQL”.

<sup>27</sup> This document has since been superseded by “BS EN 1359:1999 – Diaphragm gas meters” and subsequently “BS EN 1359:2017 – Diaphragm gas meters”.

## Annex 12 – General definitions

### **Acceptability constant ( $k$ )**

The value of  $k$  is dependent on the population size (and hence the sample size) and the defined acceptable quality level (AQL).

### **AQL**

Acceptable Quality Level/Acceptance Quality Limit. A measure of the quality routinely accepted. AQL is defined as the percent defective that the sampling plan will accept 95% of the time – i.e. lots at, or better than, the AQL will be accepted at least 95% of the time and rejected at most 5% of the time.

### **BEIS**

The former Department for Business, Energy and Industrial Strategy.

### **DBT**

The Department for Business and Trade, OPSS became part of DBT following the Machinery of Government change in February 2023.

### **Discarded meter**

A meter deemed by initial inspection to be unfit for inclusion in the sampling process and which may be replaced with an acceptable meter.

### **Defective meter**

A meter which fails to comply with the pass criteria.

### **Domestic type gas meter**

For the purposes of this document a meter with a maximum flow rate ( $Q_{\max}$ ) not exceeding  $6 \text{ m}^3/\text{h}$ .

### **Electricity meter**

For the purposes of this document a single-phase meter (4 terminal, 5 terminal and Twin Element) or whole current polyphase meter.

### **Excluded meter**

A meter that is deemed to be 'abnormally' defective and which is excluded from any statistical data but whose reason for exclusion is recorded.

### **Governance board**

A group of industry representatives chaired by OPSS and established to ensure that any changes to processes and procedures for the maintenance of in service accuracy and suitability of electricity and gas meters are implemented.

### **Grubb's test**

A method for identifying data outliers

### **$I_{\max}$**

The maximum rated current of an electricity meter

### **LSL**

Lower specification limits i.e. the maximum permissible negative error for the class of meter.

### **MAP – Meter Asset Provider**

The party responsible for the ongoing provision of the meter installation at that meter point. This could be the Meter Title Owner of the Meter, or a third party with whom the MEM contracts for the provision of a meter. For Gas meters where the Title Owner is not directly involved in the Gas Act Ownership of the Meter, the Meter Asset Provider needs to be identified so that the incoming MEM can make appropriate contractual arrangements for the ongoing provision of the metering equipment in-situ at the Meter Point.

### **Manufacturer**

A person responsible for the conformity of a relevant instrument with the essential requirements with a view to either placing it on the market under his own name or putting it into use for his own purposes, or both.

### **MEM – Metering Equipment Manager**

Means, as applicable, either:

for electricity, the 'Meter Operator Agent' (as defined in the Balancing and Settlement Code) appointed by an Electricity Supplier

or

for gas, the 'Meter Asset Manager' (as defined in the Uniform Network Code) Appointed by the Gas Supplier.

### **Meter Worker**

Actual person or organisation that will do physical work on the Assets at a Meter Point. If they are not registered as a REC Approved Meter Inspector (AMI) or on the Gas Safe Register, then the Supplier will have to arrange an inspection by an AMI to check that the installation registers accurately.

### **MID**

The European Measuring Instruments Directive [2014/32/EU](#) and the legislation implementing it in the UK – The Measuring Instruments Regulations ([SI 2016/1153](#)). Previously Directive [2004/22/EC](#) and The Measuring Instruments (Gas Meters) Regulations ([SI 2006/2647](#)) and The Measuring Instruments (Active Electrical Energy Meters) Regulations (SI 2006/1679).

### **MIR**

Measuring Instruments Regulations ([SI 2016/1153](#)). The 2016 Regulations implemented Directive 2014/32/EU on measuring instruments and replaced fifteen individual regulations (including non-prescribed instruments) with one single regulation. The EU Withdrawal Act 2018 preserved the 2016 Regulations and enabled them to be amended so as to continue to function effectively now the UK has left the EU. Accordingly, the Product Safety and Metrology etc. (Amendment etc.) (EU Exit) Regulations 2019 fixed any deficiencies that arose from the UK leaving the EU (such as references to EU institutions) and made specific provision for the GB market.

### **MPE**

Maximum Permissible Error.

### **Off Supply (formerly known as “Churn”)**

Meters which have been removed from premises as part of routine operations e.g. changing the customer from credit to prepayment, removal before the demolition of a property, removal because the supply is no longer required, etc.

### **The Office for Product Safety & Standards**

The Office for Product Safety & Standards was set up in January 2018 and is a departmental Office within the Department for Business and Trade, to enhance protections for consumers and the environment and to drive increased productivity, growth and business confidence.

### **Title (Meter) Owner**

This is also referred to as Legal Title Owner. The person or organisation to which the asset belongs, and who makes such assets available for the purpose of the Gas Act Owner.

### **Inspection lot**

Individual population being assessed.

### **Inspection lot size (N)**

Number of items in the inspection lot.

### **$Q_{\max}$**

The maximum rated flow rate of a gas meter.

### **REC**

The Retail Energy Code is a new code governing the retail aspects of the gas and electricity markets in Great Britain.

### **Sample**

Number of items taken from an inspection lot for inspection.

### **Sample average error ( $\bar{x}$ )**

Average error of a sample i.e. the sum of the errors divided by the sample size (n).

### **Sample size (n)**

The number of items in the sample.

### **Sample standard deviation (s)**

Standard deviation of the sample i.e. a measure of the spread of the test results about the average error.

### **Sampling inspection**

Inspection based on a sampling instruction in the case of which the inspection lot is assessed in accordance with the result obtained for a single sample or, if necessary, for various samples.

### **Single Phase 4 Terminal Meter**

A single-phase meter with one metrology element.

### **Single Phase 5 Terminal Meter**

A single-phase meter with one metrology element and an additional (integral) contactor.

### **Single Phase Twin Element Meter**

A single-phase meter with two metrology elements and an additional (integral) contactor.

### **Polyphase Meter (also known as Multi phase or Three Phase meters)**

A meter with three, single phase measuring elements combined to provide a single metrological output.

## **UKCA**

From the 1 January 2021 gas and electricity meters placed on the market in GB, may have the UK Conformity Assessed Mark placed on them. There is a four-year transition period, where current CE marked meters can continue to be placed on the market within GB until the 31st of December 2024. On 1st August 2023, the UK government announced the intention to extend recognition of the CE marking for placing on the market in GB indefinitely, i.e. beyond the 4 year Transition Period.

## **USL**

Upper specification limits i.e. the maximum permissible positive error for the class of meter.

## **Year of manufacture**

The MID requires that a meter be marked with the 'CE' mark, followed by the 'M' mark, then the last two digits of the year of its affixing surrounded by a rectangle. For MIR meters the marking is the 'UKCA' mark, followed by the 'M' mark, then the last two digits of the year of its affixing surrounded by a rectangle. Both are equivalent to the year of manufacture for these purposes.

## Annex 13 – IST4 membership

To date, the following suppliers are members of IST4:

British Gas  
EDF Energy  
E (Gas & Electricity) Ltd  
E.ON Next  
Good Energy  
Octopus Energy  
Outfox The Market (Foxglove Energy Supply Ltd)  
OVO Energy  
Scottish Power  
Shell Energy  
SSE ESL  
So Energy  
Utilita  
Utility Warehouse

It must be noted that ALL suppliers, have the legal responsibility to maintain their meters in proper order for correctly registering the quantity of electricity/gas supplied. IST is a method all suppliers can use to demonstrate they are conforming to the legal requirements.

The following stakeholders have contributed to the development of the IST process and/or are active members of the IST4 implementation group:

AMO (Association of Meter Operators)	George Wilson Industries Limited
BEAMA	I-nexus
Calvin Capital	Itron
CL Refurbishments Limited	Landis + Gyr UK Ltd
DNV	Macquarie Energy Leasing
Energetics	National Gas Metering
Energy Assets	Remote Energy Management
Engage Consulting	Siemens
Honeywell (Elster) Metering Ltd	SGN
EM-Lite Ltd	SGS UK Ltd
EUA (Energy and Utilities Alliance)	UKMF (UK Metering Forum)
GTC	

As mentioned in the introduction, MEMs as part of their obligation in the CoMCoP can use IST to verify the meter accuracy of those meters in their portfolio. The CoMCoP applies to Independent Gas Transporters (IGTs) undertaking meter asset management services, or MEMs who work on behalf of a gas supplier, Gas Transporter (GT) or a gas consumer, to manage primary meter installations connected to the Network as defined by the Gas Safety (Management) Regulations (GS(M)R) in Great Britain.

All interested and relevant parties are welcome to contact OPSS regarding IST and to attend meetings where appropriate. For more information email:

[gas.metering@beis.gov.uk](mailto:gas.metering@beis.gov.uk) OR [electricity.metering@beis.gov.uk](mailto:electricity.metering@beis.gov.uk)



Version 3.62 March 2024

Website: <https://www.gov.uk/guidance/in-service-testing-for-gas-and-electricity-meters>

© Crown copyright 2024

**Office for Product Safety and Standards**

Department for Business and Trade

Building 84, Stanton Avenue, Teddington, Middlesex TW11 0JZ

[www.gov.uk/government/organisations/office-for-product-safety-and-standards](http://www.gov.uk/government/organisations/office-for-product-safety-and-standards)

This publication is licensed under the terms of the Open Government Licence v3.0 except where otherwise stated. To view this licence, visit [nationalarchives.gov.uk/doc/open-government-licence/version/3](http://nationalarchives.gov.uk/doc/open-government-licence/version/3)

Where we have identified any third party copyright information you will need to obtain permission from the copyright holders concerned.

Alternative format versions of this report are available on request from

[OPSS.enquiries@beis.gov.uk](mailto:OPSS.enquiries@beis.gov.uk)