



Rail Accident Investigation Branch

# Rail Accident Report



## **Wrong side signalling failure and derailment at Dalwhinnie, Badenoch and Strathspey 10 April 2021**

Report 10/2022  
September 2022

This investigation was carried out in accordance with:

- the Railway Safety Directive 2004/49/EC
- the Railways and Transport Safety Act 2003
- the Railways (Accident Investigation and Reporting) Regulations 2005.

© Crown copyright 2022

You may reuse this document/publication (not including departmental or agency logos) free of charge in any format or medium. You must reuse it accurately and not in a misleading context. The material must be acknowledged as Crown copyright and you must give the title of the source publication. Where we have identified any third party copyright material you will need to obtain permission from the copyright holders concerned. This document/publication is also available at [www.gov.uk/raib](http://www.gov.uk/raib).

Any enquiries about this publication should be sent to:

RAIB	Email: <a href="mailto:enquiries@raib.gov.uk">enquiries@raib.gov.uk</a>
The Wharf	Telephone: 01332 253300
Stores Road	Website: <a href="http://www.gov.uk/raib">www.gov.uk/raib</a>
Derby UK	
DE21 4BA	

This report is published by the Rail Accident Investigation Branch, Department for Transport.

## Preface

The purpose of a Rail Accident Investigation Branch (RAIB) investigation is to improve railway safety by preventing future railway accidents or by mitigating their consequences. It is not the purpose of such an investigation to establish blame or liability. Accordingly, it is inappropriate that RAIB reports should be used to assign fault or blame, or determine liability, since neither the investigation nor the reporting process has been undertaken for that purpose.

RAIB's findings are based on its own evaluation of the evidence that was available at the time of the investigation and are intended to explain what happened, and why, in a fair and unbiased manner.

Where RAIB has described a factor as being linked to cause and the term is unqualified, this means that RAIB has satisfied itself that the evidence supports both the presence of the factor and its direct relevance to the causation of the accident or incident that is being investigated. However, where RAIB is less confident about the existence of a factor, or its role in the causation of the accident or incident, RAIB will qualify its findings by use of words such as 'probable' or 'possible', as appropriate. Where there is more than one potential explanation RAIB may describe one factor as being 'more' or 'less' likely than the other.

In some cases factors are described as 'underlying'. Such factors are also relevant to the causation of the accident or incident but are associated with the underlying management arrangements or organisational issues (such as working culture). Where necessary, words such as 'probable' or 'possible' can also be used to qualify 'underlying factor'.

Use of the word 'probable' means that, although it is considered highly likely that the factor applied, some small element of uncertainty remains. Use of the word 'possible' means that, although there is some evidence that supports this factor, there remains a more significant degree of uncertainty.

An 'observation' is a safety issue discovered as part of the investigation that is not considered to be causal or underlying to the accident or incident being investigated, but does deserve scrutiny because of a perceived potential for safety learning.

The above terms are intended to assist readers' interpretation of the report, and to provide suitable explanations where uncertainty remains. The report should therefore be interpreted as the view of RAIB, expressed with the sole purpose of improving railway safety.

Any information about casualties is based on figures provided to RAIB from various sources. Considerations of personal privacy may mean that not all of the actual effects of the event are recorded in the report. RAIB recognises that sudden unexpected events can have both short- and long-term consequences for the physical and/or mental health of people who were involved, both directly and indirectly, in what happened.

RAIB's investigation (including its scope, methods, conclusions and recommendations) is independent of any inquest or fatal accident inquiry, and all other investigations, including those carried out by the safety authority, police or railway industry.

This page is intentionally left blank

# Wrong side signalling failure and derailment at Dalwhinnie, Badenoch and Strathspey, 10 April 2021

## Contents

<b>Preface</b>	3
<b>Summary</b>	7
<b>Introduction</b>	9
Definitions	9
<b>The accident</b>	10
Summary of the accident	10
Context	12
<b>The sequence of events</b>	18
<b>Background information</b>	24
<b>Analysis</b>	33
Identification of the immediate cause	33
Identification of causal factors	35
Identification of underlying factors	49
Observations	51
Previous occurrences of a similar character	52
<b>Summary of conclusions</b>	54
Immediate cause	54
Causal factors	54
Underlying factor	55
Additional observation	55
<b>Previous RAIB recommendations relevant to this investigation</b>	56
<b>Actions reported as already taken or in progress relevant to this report</b>	58
<b>Recommendations and learning points</b>	60
Recommendations	60
Learning points	62
<b>Appendices</b>	63
Appendix A - Glossary of abbreviations and acronyms	63
Appendix B - The circuitry associated with 13 points	64

This page is intentionally left blank

## Summary

At around 03:01 hrs on 10 April 2021, an empty coaching stock train derailed at around 33 mph (53 km/h) after being wrongly diverted from the main line onto a crossover south of Dalwhinnie station, Badenoch and Strathspey. No one was injured. However, the consequences could have been much worse; the train could have been travelling much faster and carrying passengers or encountered a train travelling on the line to which the crossover led.

The train was wrongly diverted because, even though the signaller had recently called the double-ended set of points to be in a position for the route along the main line, the points at the facing end of the crossover had remained set towards the crossover, while the points at the trailing end had moved to the correct position. The signaller was able to clear the protecting signal, which allowed the train to approach the crossover in this condition, because of a wiring error in the signalling system that was introduced when the point machine at the trailing end was replaced some nine months earlier. The front of the train was directed over the crossover and then trailed through and forced apart the points at the trailing end. The signalling system only then detected that the points were not correctly set and automatically re-sent a command for both point ends to move to the position that the signaller had earlier commanded. This caused the points at the facing end to move under the train, which derailed the rear of train as it passed over them.

The wiring error was the result of two unwanted conductors, a wire strap and a metal link, within the replacement trailing end point machine. These conductors were only required when this type of point machine was installed at single-ended point locations. The local signalling maintenance team was responsible for installing and testing the replacement point machine. The team did not appreciate that the crossover at Dalwhinnie was unique to the area and that, because of the design of the point position detection circuit that the two point machines shared, these conductors needed to be removed from the point machine when it was installed.

The need to alter the internal wiring was not identified when the renewal work was planned. The point machine was tested and commissioned following processes that Network Rail prescribes for signalling maintenance work when installing a like-for-like replacement. The checks and wire counting that were required before and after the point machine was installed did not identify the wiring discrepancy. The last opportunity to identify the wiring error before the points were handed back into service was an out-of-correspondence test. However, the specified testing work was interrupted by the need to wait for the signaller to arrive at the signal box. As a result, this and other outstanding testing work was overlooked, the tester in charge believing that it had already been completed.

RAIB found a lack of clarity in Network Rail's signalling maintenance standards concerning the working arrangements of the appointed tester and of those carrying out this type of like-for-like installation work. It has identified this as a probable underlying factor.

RAIB has made five recommendations directed to Network Rail covering:

- the definition of the tasks and responsibilities of its signalling maintenance teams when carrying out pre-planned like-for-like equipment replacement work, and how the independence of testing and installation roles is best assured
- the provision of information and warnings for replaceable items of signalling equipment, and the effectiveness of pre-installation checks
- the arrangements for recording the progress and findings of signal maintenance testing.



# Introduction

## Definitions

- 1 Metric units are used in this report, except when it is normal railway practice to give speeds and locations in imperial units. Where appropriate the equivalent metric value is also given.
- 2 All mileages in this report are measured from a datum at Perth station. At Dalwhinnie, trains travel south towards Perth on the up line. The directions left and right are relative to the direction of travel of the train.
- 3 The report contains abbreviations. These are explained in appendix A.

## The accident

### Summary of the accident

- 4 At around 03:01 hrs on 10 April 2021, a train, reporting number 5S85, derailed on a crossover, 13 points, south of Dalwhinnie station, Badenoch and Strathspey (figure 1). Train 5S85 was an empty coaching stock train that was being used to carry out platform interface tests (checking the stepping height and lateral gap between the platform and the train door sills) in advance of the planned introduction of longer trains.

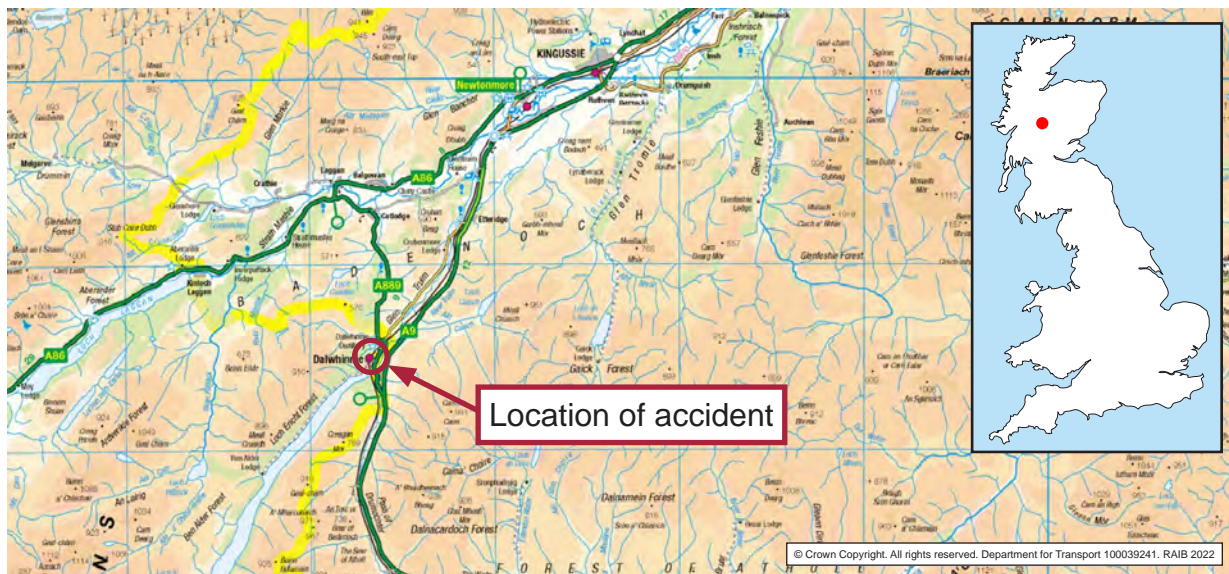
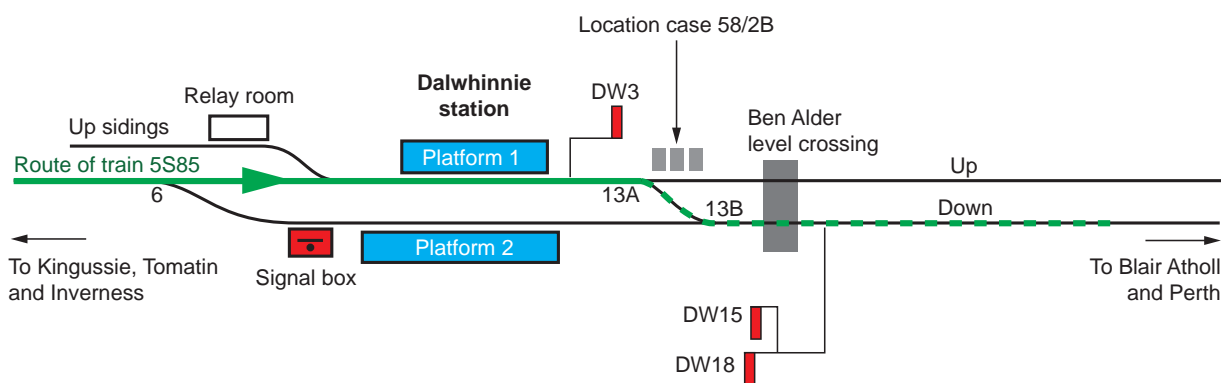
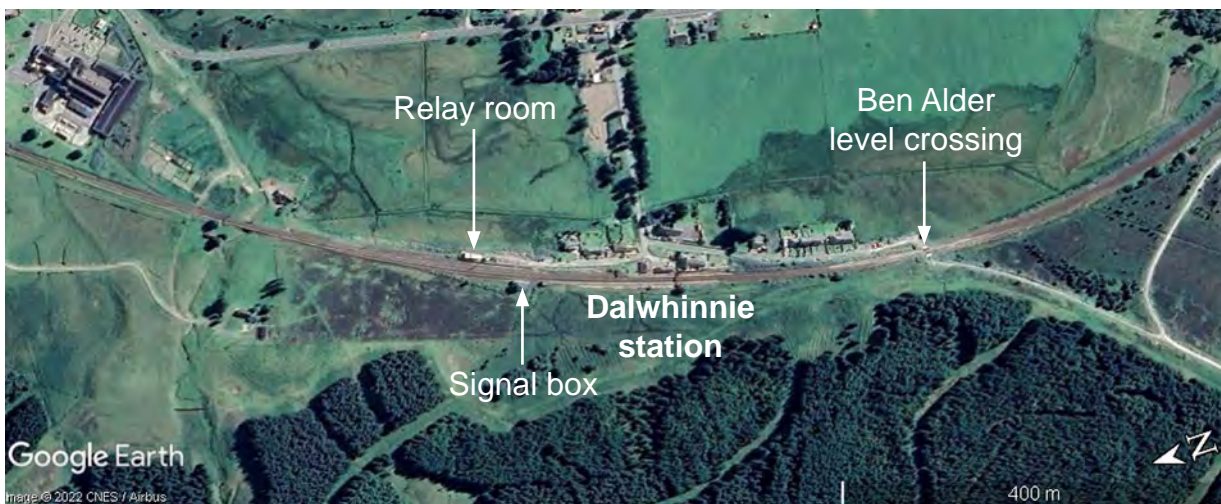

Figure 1: Extract from Ordnance Survey map showing location of the accident

- 5 On completion of the test work in platform 1 on the up line, onboard staff gave the driver the instruction to depart from the station (figure 2). The signaller had already set the route so the train could continue south along the same line. This included operating DW3 signal to show a proceed aspect on the approach to the double-ended set of points forming the crossover. On reaching the A end of the points (13A point end), the train was travelling at around 25 mph (40 km/h). The train was wrongly diverted onto the crossover leading to the down line because the switch rails (the movable rail sections within a set of points) were not in the correct position. The front of the train then ran through the B end of the points (13B point end) proceeding onto the down line in the wrong direction. In doing so, the train damaged the 13B point end, which was correctly set for trains travelling northbound along the down line. The damage to 13B point end led the signalling system to recognise that the point ends were not in the correct position. The signalling system then automatically commanded both ends of the points to move in order to correct this. This resulted in the switch rails at 13A point end moving, which derailed the last three bogies on the train (figure 3). At this point, the train was travelling at a speed of around 33 mph (53 km/h). Shortly after, the on-train data recorder (OTDR) registered a loss of brake pipe air pressure and the train started to slow.<sup>1</sup>

<sup>1</sup> Most likely as a result of the brake pipe (which runs continuously through the train) separating when the rear of the train started to run derailed, the train brakes then applying automatically.



13A point end correctly set for up line

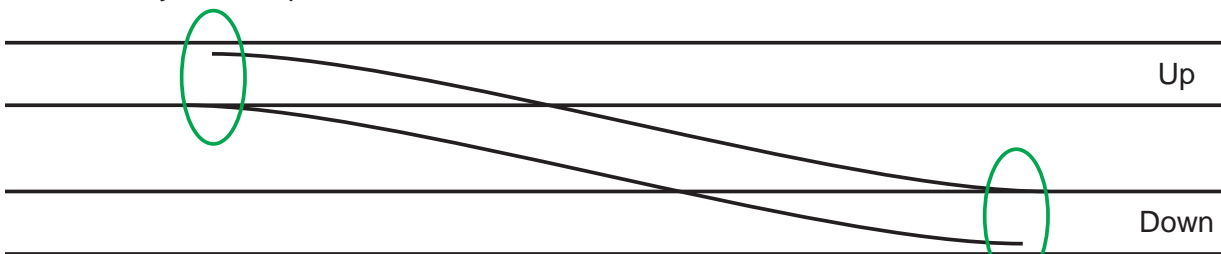

**13 points correctly set (for routes along main line)**

13B point end correctly set for down line

13A point end wrongly set for crossover

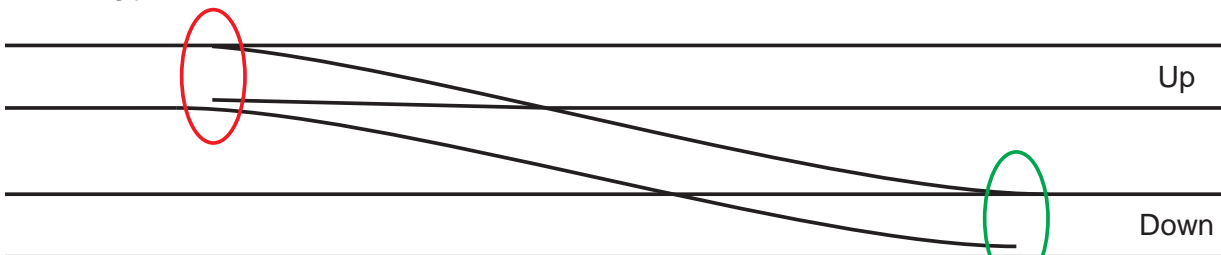

**13 points wrongly set (out-of-correspondence)**

13B point end correctly set for down line

Figure 2: Layout of the railway at Dalwhinnie station showing the route of the train. The lower diagrams shows 13 points in the correct and incorrect (as encountered by the train) positions.



Figure 3: Derailed train – trailing power car and coaches

- 6 The driver, who had started to reduce power, felt a lurch as the train moved across onto the down line. He applied the emergency brake as the train stopped. The rear of the train came to a stand around 35 metres beyond the toes<sup>2</sup> of 13B point end. The driver then alerted the signaller.
- 7 The derailment resulted in damage to both the train and the railway infrastructure, mainly the track and signalling equipment at 13 points and the deck of the nearby Ben Alder level crossing. Although no one was injured, trains are permitted to travel at up to 70 mph (113 km/h) through Dalwhinnie station on the up line, while movements over the crossover are restricted to 15 mph (24 km/h) (see paragraph 10). This means that the train could have been travelling at a much higher speed when the derailment occurred; it could also have been carrying passengers. The train could also have encountered a train travelling northbound on the down line.

## Context

### Location

- 8 Dalwhinnie station is located at 58 miles 47 chains on the Highland main line between Perth and Inverness. The railway here runs through remote mountain terrain. Trains from Inverness approach Dalwhinnie from the north on a single line. This divides into the up line (platform 1) and down line (platform 2) at 6 points, a single-ended set of points located north of the station. The two lines continue southwards to Blair Atholl (35 miles 9 chains), where they rejoin. Trains on the down line can be routed over the crossover, at 13 points, onto the up line for access to platform 1 and the up sidings (figure 2).
- 9 The signalling at Dalwhinnie is controlled from the signal box at the north end of platform 2. The adjoining sections to the north and the south are controlled from the signal boxes at Kingussie and Blair Atholl, respectively. The single track line to the north is signalled according to the Scottish Region tokenless block system.<sup>3</sup> The up and down lines to Blair Atholl are signalled using absolute block principles.<sup>4</sup>

<sup>2</sup> The switch rail ends.

<sup>3</sup> A system of signalling single track lines that was developed for use in the former British Rail Scottish Region.

<sup>4</sup> A system of signalling that allows only one train to be in a section of the line (the block section) at one time.

- 10 The maximum permitted speeds through the station are 70 mph (113 km/h) for trains travelling in the up direction, 80 mph (129 km/h) for those in the down direction and 15 mph (24 km/h) over the crossover at 13 points.

### Organisations involved

- 11 Network Rail owns and manages the railway infrastructure where the derailment occurred. It is part of the Scotland route. Network Rail Scotland route is the only route business within Network Rail's Scotland region, which is known as 'Scotland's Railway'.
- 12 The point machines at 13 points had been reserviced by Unipart Rail, a Network Rail approved supplier.
- 13 Rail Operations Group operated train 5S85 and employed the driver. The platform interface testing was being undertaken for ScotRail as part of plans to introduce longer formation passenger trains on the line. ScotRail staff were on board the train to operate the train doors and assist with the platform interface checks.
- 14 Network Rail, Unipart Rail, Rail Operations Group and ScotRail freely co-operated with the investigation.

### Train involved

- 15 Train 5S85 was in the longer formation that ScotRail planned to introduce. This consisted of two class 43 diesel electric power cars and five mark 3 coaches (table 1). The train had previously run north as train reporting number 5S84.

Vehicle	Number	Derailment outcome
Power car (leading)	43015	Both bogies diverted on to the down line without derailling
Coach A (first, buffet)	40619	Both bogies diverted on to the down line without derailling
Coach B (standard)	42255	Both bogies diverted on to the down line without derailling
Coach C (standard)	42568	Both bogies diverted on to the down line without derailling
Coach D (standard)	42256	Both bogies diverted on to the down line without derailling
Coach E (standard)	42029	Leading bogie diverted on to the down line without derailling; trailing bogie derailed at 13A point end
Power car (trailing)	43012	Both bogies derailed at 13A point end

Table 1: Formation of train 5S85 with summary of the derailment outcome

### Signalling system and equipment

- 16 The signals and points at Dalwhinnie are controlled from the lever frame in the signal box. On a shelf above this are the instruments for offering and accepting trains to and from Kingussie and Blair Atholl, and indicator lamps showing the status of signals and points. There is also a diagram of the railway. Track circuits are installed through the station and lamps on the diagram indicate when these are detected as occupied by trains. The signalling controls and the diagram are shown in figure 4.



Figure 4: Signalling controls in Dalwhinnie signal box (main photograph courtesy of Network Rail)

- 17 The point ends at 13 and 6 points are operated by GRS 5E type electromechanical point machines (figure 5). The required position of the points is called by the signaller and controlled by the interlocking<sup>5</sup> in the Dalwhinnie relay room located near the up sidings (figure 2). Relays in lineside location case 58/2B provide local control of the point machines at 13 points and indications to the interlocking of the detected position of the switch rails (see appendix B).

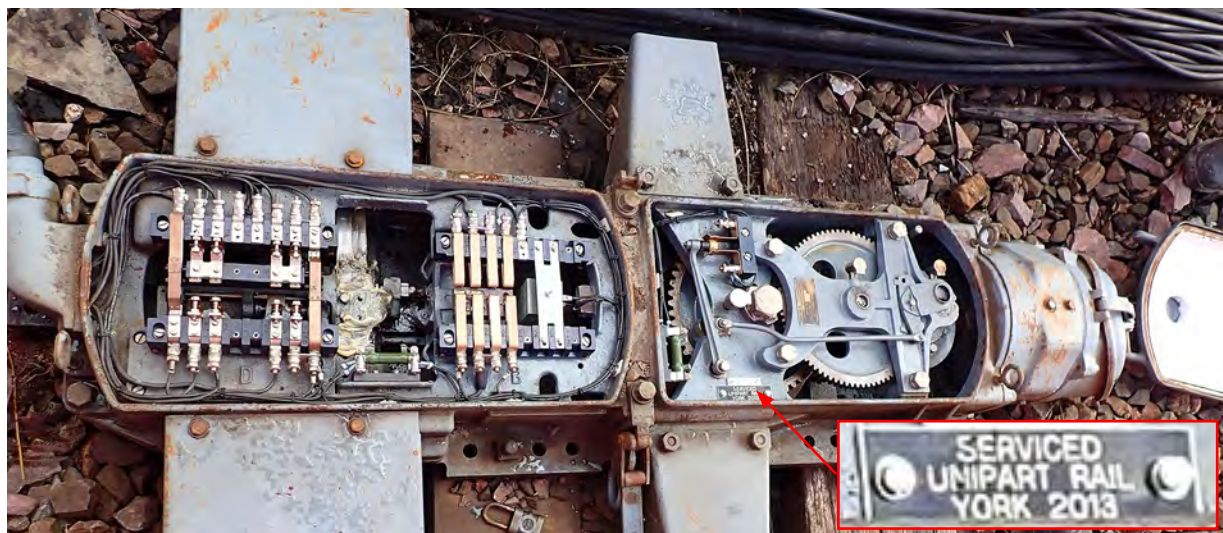

Figure 5: GRS 5E type point machine installed at 13A point end, with covers removed. Inset shows the plate fitted when it was last reserviced

- 18 The GRS 5E type point machine is of a historical design and is no longer manufactured. On the Highland main line, they are only installed on Network Rail managed infrastructure between Dalwhinnie and Inverness. Network Rail signalling engineers recalled that the first machines of this type were fitted in the 1980s.
- 19 Network Rail had developed a preventative maintenance strategy that involved replacing each GRS 5E type point machine approximately every seven years with an equivalent unit reserviced by Unipart Rail (paragraph 12). The point machine at the 13A point end was last replaced on 10 November 2013. The point machine at the 13B point end was replaced on 28 June 2020, around nine months before the derailment.

### Signalling asset management and maintenance

- 20 The regional asset manager for signalling (Scotland RAM(S)) is accountable for the management of all signalling assets within the Scotland region. This includes the approval of expenditure for signalling renewal work. Signalling renewals can range from large scale re-signalling schemes, involving major signalling suppliers and extensive design work, to the scheduled replacement of components and individual items of equipment, such as point machines. Network Rail refers to the latter as minor signalling renewal work.

<sup>5</sup> Controls between points and signals that prevent the signaller setting routes which could result in unsafe train movements.

- 21 The signalling and telecoms maintenance engineer at the Perth maintenance delivery unit<sup>6</sup> (Perth S&TME) is responsible for the routine maintenance of the signalling infrastructure on the Highland main line. The Perth S&TME reports to the delivery unit infrastructure maintenance engineer and separately refers to the Scotland RAM(S) for technical matters, such as signalling standard updates and revisions.
- 22 The signalling equipment at Dalwhinnie is maintained by a team reporting to the signalling and telecoms section manager based at Network Rail's depot in Inverness (Inverness section manager). The team comprises a section supervisor (Inverness section supervisor), a section planner and six teams of three signalling maintenance staff, each with a team leader. The Inverness section manager, along with his counterparts at Dundee, Aberdeen and Perth, reports directly to the Perth S&TME.
- 23 The core hours worked by the depot teams reporting to the Perth S&TME are focused on the maintenance, inspection, fault-finding and repair work needed to keep the signalling equipment in a safe operational condition. However, there was a longstanding arrangement that the teams would also undertake minor signalling renewal work when time and resources allowed. The Scotland RAM(S) agreed an annual budget and scope for this work. The depot teams refer to it as capital expenditure (CapEx) work since it is not funded from their normal operating budgets.
- 24 The replacement of the point machine at the 13B point end on 28 June 2020 was completed as CapEx work by staff from the Inverness depot who were available to work overtime that day. The renewal team comprised:
- The person responsible for the testing that was required to verify the integrity of the work carried out (maintenance tester). One of the team leaders was allocated this role and was also allocated to be the controller of site safety (COSS, the person competent and appointed to manage the safe system of work on Network Rail infrastructure), and the person in charge (PIC, the person in overall charge of the work activity).
  - Four other signalling maintenance staff who were tasked with carrying out the work (installers), one of whom informally assumed the lead role (see paragraph 158).
- 25 Routine maintenance work was also planned at Dalwhinnie that day. This was so that other signalling maintenance staff would be available to help with manual handling of the point machine.

### External circumstances

- 26 Witness reports indicate that it was raining at Dalwhinnie when the point machine was replaced on 28 June 2020. Around this time, the weather station near Drumochter summit, 9 km to the south, recorded rainfall of between 1 and 2 mm/h. Rainfall may be relevant to the accident (see paragraphs 111, 112 and 147). The weather station recorded an air temperature of 8°C and a wind speed of around 10 km/h.

---

<sup>6</sup> An organisational unit responsible for the maintenance of the railway infrastructure within a geographical area.



- 27 It was dark when the derailment occurred on 10 April 2021. The weather station recorded an air temperature of  $-4^{\circ}\text{C}$  and a wind speed of around 2 km/h. No precipitation was recorded.

## The sequence of events

### Events preceding the accident

#### 13B point machine replacement

- 28 The Inverness section manager and Inverness section supervisor arranged to replace the point machine at the 13B point end during line blockages<sup>7</sup> that were to be taken after the last train had passed on the evening of Saturday 27 June 2020. Dalwhinnie signal box closes overnight and reopens for the first train from Inverness on Sunday morning. This is normally the train to London King's Cross, reporting number 1E17. The plan was for the renewal team to arrive early on Sunday morning, complete the renewal, and hand back the railway before this train was due to pass Dalwhinnie at 10:51 hrs. The Inverness section supervisor allocated staff to the renewal team and issued the maintenance test plan list, a document that specified the maintenance test plan<sup>8</sup> that the maintenance tester was to follow. The section planner prepared the safe system of work pack describing the safe system of work to be used while on the railway, the risk control arrangements and other site and task-related information. The Inverness section manager authorised this on 26 June.
- 29 The safe system of work pack recorded that another member of the depot team was the first COSS to take charge of the site. They visited Dalwhinnie on Saturday evening to arrange the line blockages and to make the track circuit disconnections in the relay room used to provide additional protection.<sup>9</sup> The Dalwhinnie signaller granted the line blockage on the up line at 20:20 hrs on 27 June. The Blair Atholl signaller granted the line blockage on the down line at 20:40 hrs. A hand-back time of 10:30 hrs (on 28 June) was agreed and recorded on both line blockage forms. The train register (the book used by a signaller to record the movements of trains) recorded the Dalwhinnie signaller reporting off duty at 20:47 hrs, with the signal box then closing. No renewal work was done overnight.
- 30 The five members of the renewal team met up in Inverness depot at around 06:00 hrs on Sunday morning (28 June). The maintenance tester recalled the first COSS sending him the safe system of work pack<sup>10</sup> by email. The Inverness section supervisor had left the maintenance test plan list in the depot office for the maintenance tester to collect. The maintenance tester knew that he would be doing CapEx work at Dalwhinnie from the weekly roster, but witness evidence is that he did not know he was appointed to the maintenance tester role until he arrived that morning.

<sup>7</sup> A type of protection arrangement where signals are used to prevent train movements on a specified section of line.

<sup>8</sup> Maintenance test plans are Network Rail documents that predefine the testing and commissioning tasks required when certain types of signal maintenance work are carried out (see paragraphs 53 to 56).

<sup>9</sup> Rules for blocking a line require signals being kept at danger together with an additional means of protection if work affects the safety of the line.

<sup>10</sup> This included the line blockage forms.

- 31 The reserviced point machine that the renewal team was to install was on a pallet in the depot compound. Two of the installers (installer A and installer B) loaded it onto a flatbed truck. The renewal team was aware that GRS 5E type point machines need to be configured according to the turnout direction (left or right) and it is likely that they checked this at the time. Because of COVID-19 infection precautions, the five members of the renewal team travelled to Dalwhinnie in three separate vehicles. They parked near Ben Alder crossing and the maintenance tester completed the COSS safety briefing. The signalling data logger recorded that the power supply to the existing 13B point machine was removed at 07:40 hrs. This disconnection was achieved by sliding disconnection links in the location case (paragraph 17).
- 32 Installer A moved the flatbed truck onto the crossing deck and lowered the replacement point machine onto the ground next to the point machine being replaced. Having removed the covers on the replacement unit, installer A proceeded to check the internal wiring against the site wiring drawings kept in the location case. At the time, the maintenance tester recalled he was helping the installers who were making the mechanical disconnections to the existing point machine. However, the maintenance tester was aware of what installer A was doing, and installer A recalled telling the maintenance tester about the internal wiring checks.
- 33 The existing 13B point machine was then unbolted and moved to one side with the tail cables (the external cables that connected it to the location case) still attached. The replacement point machine was then lifted into place and installers A and B began the process of transferring the tail cables from the existing point machine on to it. The maintenance tester recalled being present during this work. Installer A recalled that the work continued and included the completion of other tasks, such as the required detection and facing point lock tests.<sup>11</sup> The signalling data logger recorded that the power was reconnected at 08:52 hrs. Shortly afterwards, it recorded six cycles of the point machine detecting, and then not detecting, that the switch rails were set in the normal position.<sup>12</sup>
- 34 The installation work was now considered complete. However, the maintenance tester could not complete some of the steps on the maintenance test plan because the signaller had yet to arrive and was needed to operate controls and observe indications in the signal box. He decided that work would need to stop pending the arrival of the signaller. This was probably at around 09:02 hrs, when the signalling data logger recorded normal point position detection had been regained. The renewal team replaced the covers on the newly-installed point machine, tidied up and returned to their respective vehicles to wait.

---

<sup>11</sup> This testing involved using a handle to manually operate the point machine to the normal (for train movement along the down line) and reverse (for a divergent movement over the crossover) positions, and checking the state of electrical contacts in the point position detection wiring circuits at different stages of the tests.

<sup>12</sup> There is witness evidence that this related to a test done to confirm the operation of the detection relay in the location case during which installer A repeatedly broke and remade the detection contacts in the point machine while another installer observed the state of the detection relay.

- 35 At 09:51 hrs a member of the depot team, who was at Dalwhinnie to carry out routine maintenance work (paragraph 25), signed in with the maintenance tester as an additional COSS. Since the maintenance tester retained overall responsibility for the line blockages, he had now acquired the additional role of protection controller (the person competent and appointed to manage arrangements where two or more COSSs are working within the same line blockage).
- 36 The maintenance tester recalled calling the signal box several times during this period, but there was no answer. He eventually asked installer B to drive him to the signal box. Once there, he found that the signaller had only just come on duty and needed some time to get organised. Once the signaller was ready, the maintenance tester asked them to call 13 points to the reverse position, and then back to normal. The signalling data logger recorded that this happened at 10:07 hrs. Concerned about the need to hand back the line blockages in time (paragraph 29), he proceeded to sign out the additional COSS and to go to the relay room to reconnect the track circuits. By 10:24 hrs, he had handed back both lines as being safe for trains to run.
- 37 The maintenance tester incorrectly believed that he had now completed all the tasks on the maintenance test plan. He filled in both the SMTH log sheet (see paragraph 53, and also footnote 24) and the maintenance test plan list (paragraph 28). The documents record a time of 10:20 hrs (figure 6). This is the time when he would have been in the relay room. However, the maintenance tester recalled completing the documents when he was back in his vehicle, which was sometime later.
- 38 Afterwards, he went back to 13B point end and took a photograph of the newly-installed point machine (figure 7). At 10:37 hrs, he emailed this and a photograph of the completed SMTH log sheet and maintenance test plan list to a central mailbox that Network Rail uses in Scotland to collate signal maintenance test records. He told the renewal team that their work was complete, and they all returned to Inverness.

### Train operation

- 39 The derailment on 10 April 2021 occurred around nine months after the point machine at 13B point end was replaced. The train involved first arrived at Dalwhinnie on the down line when travelling northbound as train 5S84 (paragraph 15) and stopped at the signal before 13 points (DW15 signal, figure 2) at around 00:36 hrs. At that time, 13 points were set in the normal position. The driver asked the signaller for a route into platform 1 so interface checks could be made.
- 40 At 00:41 hrs, the signaller replaced DW18 signal to danger, called 13 points to the reverse position and cleared DW15 signal. The train proceeded over the crossover into platform 1. At 00:45 hrs, once the train was in platform 1, the signaller called 13 points back to the normal position, stating afterwards that they had obtained the correct signal box indications. After the platform interface checks were complete, train 5S84 continued to Tomatin,<sup>13</sup> stopping at other stations on the way.

---

<sup>13</sup> A passing loop 21 km south-east of Inverness.

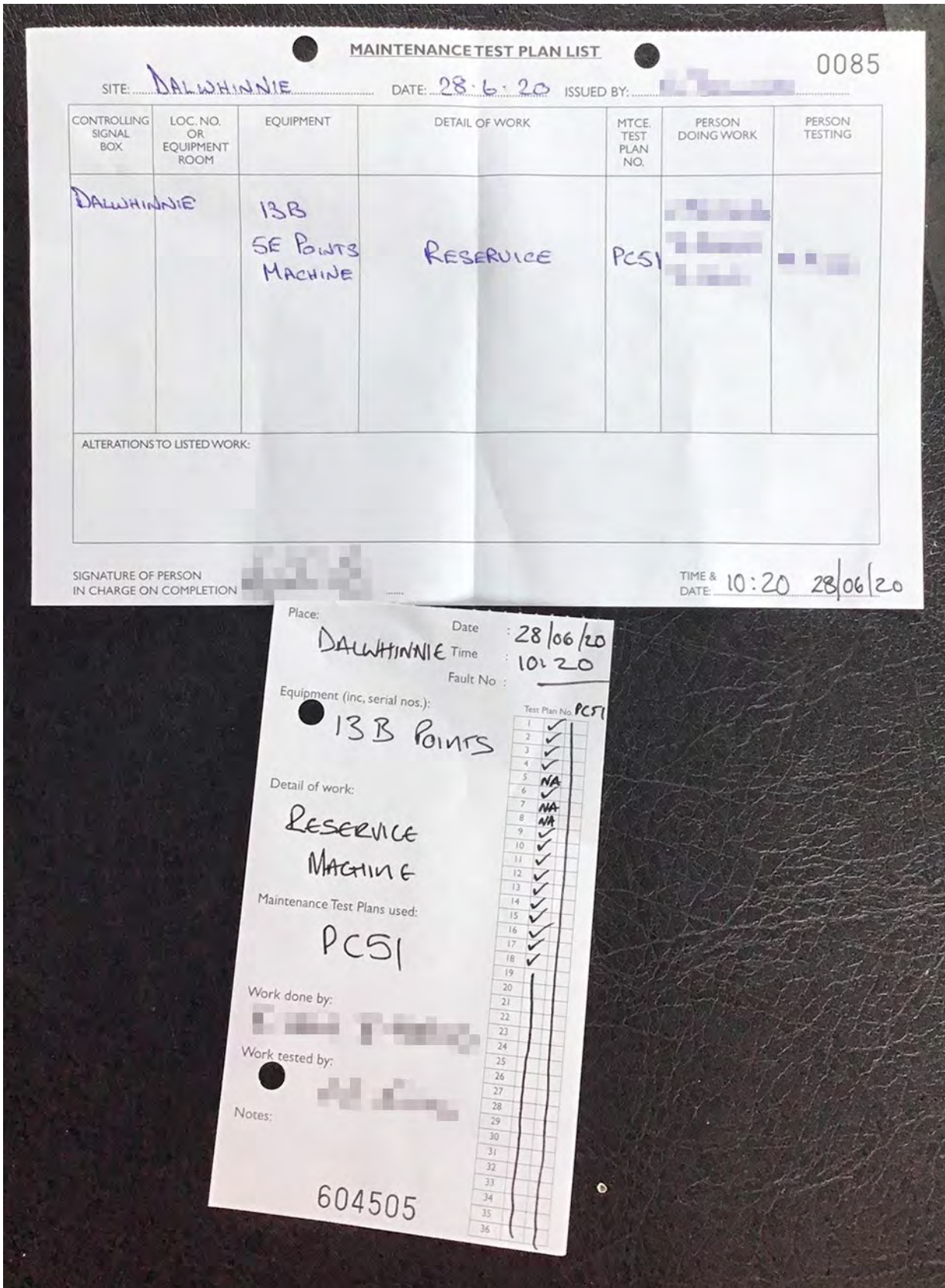

Figure 6: Completed SMTH log sheet and maintenance test plan list (photograph courtesy of Network Rail)



Figure 7: The newly-installed point machine at 13B point end (photograph courtesy of Network Rail)

- 41 The train, now designated as train 5S85, departed south from Tomatin at 02:12 hrs. At 02:23 hrs, the Kingussie signaller asked the Dalwhinnie signaller to confirm that the line into the station was clear. At 02:35 hrs, the Dalwhinnie signaller asked the same of the Blair Atholl signaller for the line beyond the station. The Dalwhinnie signaller then started to clear the signals so that the train could continue its southbound journey through the station on the up line.

#### Events during the accident

- 42 The signaller cleared DW3 signal at 02:35:45 hrs and again recalled obtaining the correct signal box indications. Train 5S85 arrived in platform 1 at 02:55 hrs and stopped to carry out the platform interface checks, this time for a southbound train movement. A ScotRail conductor team manager was operating the train doors. He observed that DW3 signal was clear. When the checks were complete and the crew were back on board, he closed the doors and gave the driver permission for the train to start.
- 43 The driver checked DW3 signal and, after acknowledging the conductor team manager's permission to start, applied power and the train began to move. It was now 03:00:28 hrs. From analysis of the OTDR, the front of the train passed over the toes at 13A point end around 25 seconds later, travelling at around 25 mph (40 km/h). It was dark and the driver realised the train had been wrongly diverted onto the down line when he felt it lurch. Shortly afterwards, the OTDR registered a loss of brake pipe air pressure, and the train started to slow.

- 44 The driver applied the emergency brake as the train came to a stand. He then called the signaller on the Global System for Mobile Communications-Railway (GSM-R) radio. The signaller reported that he had already been trying to speak with the driver because of alarms that were sounding in the signal box. The driver walked back along the train to investigate. He called the signaller back at 03:12 hrs to advise that the rear power car had derailed. He requested that both lines be blocked to all train movements. The signaller updated route control at 03:15 hrs.

#### Events following the accident

- 45 Network Rail immediately mobilised staff to site and notified train operators, RAIB and other industry parties. RAIB deployed two inspectors to site. Signalling maintenance staff started structured signal failure investigation testing at around 20:45 hrs. The testing continued over the following two days and identified a wiring discrepancy in the 13B point machine that had been installed on 28 June 2020.
- 46 Network Rail decided to remove the crossover and install plain line track where 13 points had been. The 13A and 13B point machines were taken to Inverness for storage. The railway was reopened at 04:42 hrs on 15 April 2021, five days after the derailment.

## Background information

### Post-derailment examination of the track and train

47 RAIB inspected the track and the derailed train at Dalwhinnie finding marks and damage at 13B point end indicating that:

- The left-hand wheels initially encountered the switch rail closed against the stock rail (the fixed rail section within a set of points), and that the train's wheels had prised the switch rail away from the stock rail as they passed.
- The right-hand wheels had forced, and deformed, the opposite switch rail against its stock rail.

Both are consistent with the leading wheelsets being diverted onto the crossover after encountering 13A point end (incorrectly set) in the reverse position, and then encountering 13B point end (correctly set) in the normal position and running through onto the down line in the trailing direction<sup>14</sup> (figures 2 and 8).

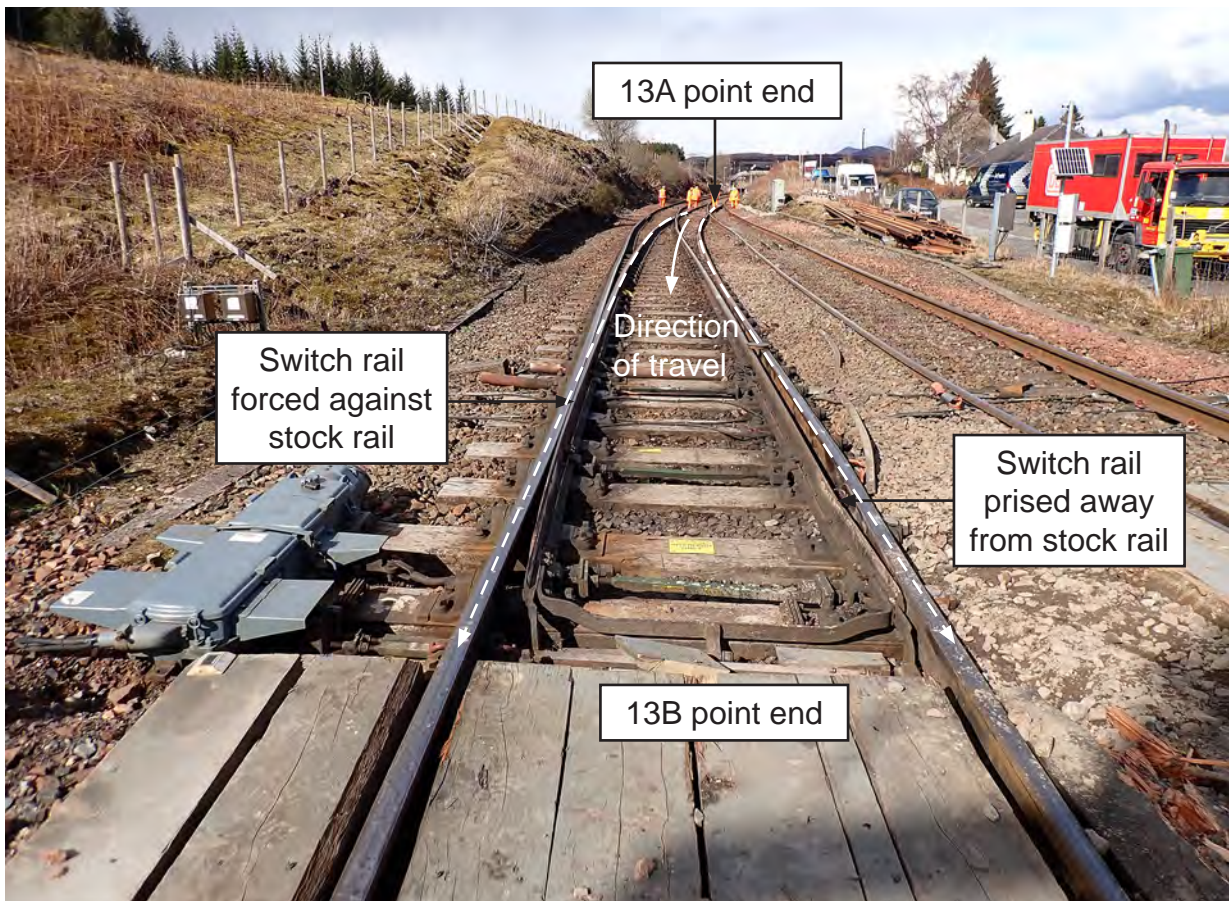

Figure 8: Track damage at 13B point end, showing paths of the wheels that ran through

<sup>14</sup> The direction through a set of points where two (or more) routes converge.



48 At 13A point end, marks showed evidence of the left-hand and right-hand wheels dropping off the railhead. They then showed the left-hand wheels running in the four-foot (the area of the track between the running rails) of the up line, and the right-hand wheels running in the four-foot of the crossover. There was no evidence of left-hand wheels striking the toe of the switch rail (figure 9). Other marks showed the paths of the right-hand wheels continuing in the four-foot of the crossover and then climbing into the six-foot (the area of the railway between two adjacent tracks, in this case between the up and down lines) at 13B point end (figure 10). The marks and damage continued up to the final resting position of the derailed bogies. This evidence is consistent with the wheels on the last three bogies encountering the switch rails at 13A point end midway between their normal and reverse positions, and then derailing.

#### Signalling circuitry associated with 13 points

49 Appendix B contains a description of the signalling circuitry associated with the operation and detection of 13 points.

#### Applicable Network Rail signal engineering standards

50 Network Rail company standards define two regimes for the testing and commissioning of newly installed signalling equipment on its infrastructure: signal works testing and signal maintenance testing. Other standards define requirements and guidance for signalling installation and maintenance work.

#### Signal works testing

51 Signal works testing is used for signalling renewal and other work that alters Network Rail's infrastructure or has the potential to affect its 'fitness for purpose'. The requirements are set out within Network Rail company standard NR/L2/SIG/30014 'Signal Works Testing Handbook' (SWTH) in standalone modules that are grouped into chapters. The requirements include:

- the appointment of a person to be in overall charge of the testing (tester in charge)
- the need for independence between those testing and those who designed and installed the work
- the documentation of the testing and commissioning process
- the preparation of a testing strategy and the production of a documented test plan
- the need for the tester in charge to be provided with design information and related documentation
- the arrangements for handing over the installed work for testing
- the competence of those carrying out the testing
- a system of test recording and certification.

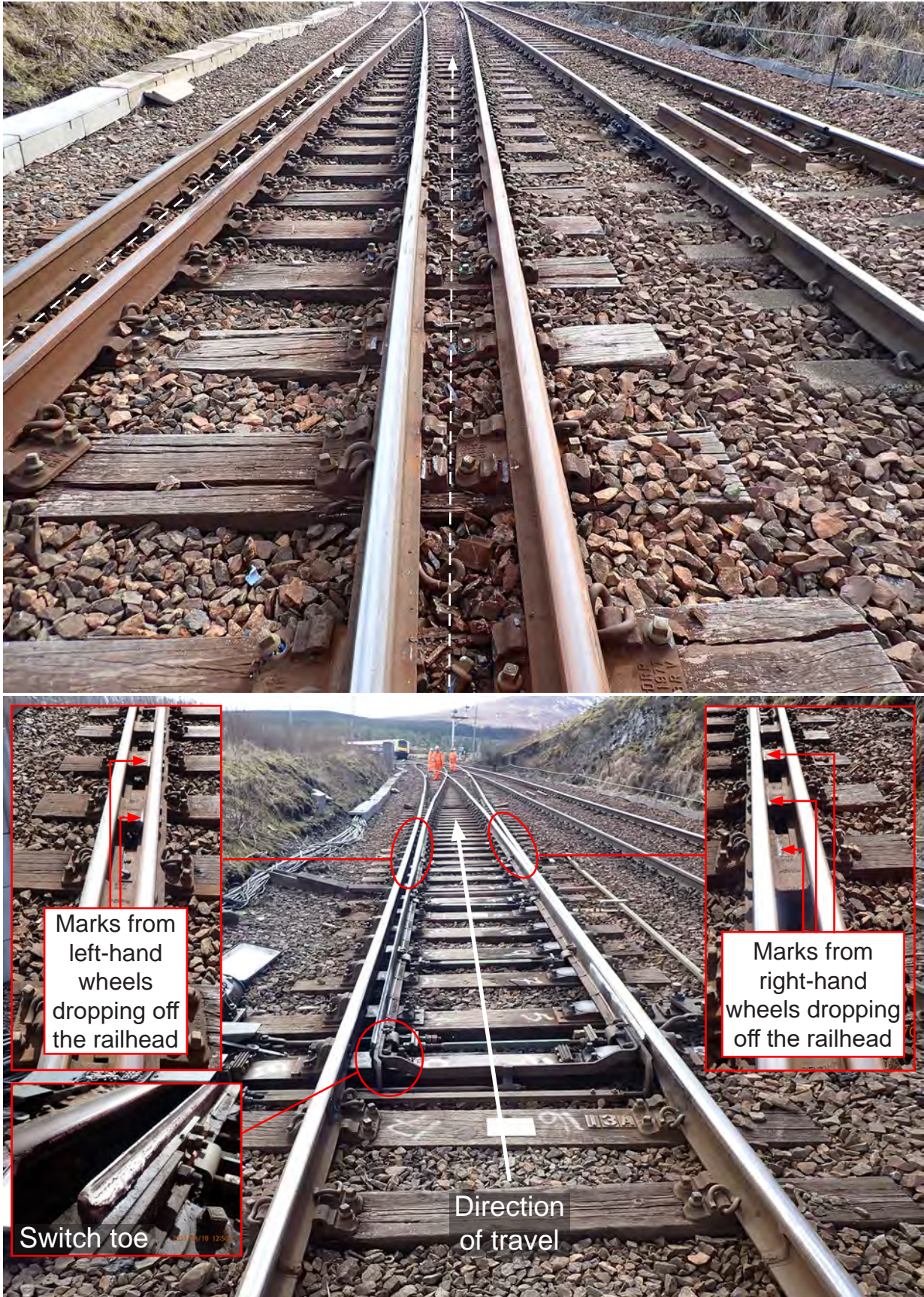

Figure 9: Derailment marks at 13A point end, switch rails in the normal position (as found after the derailment)

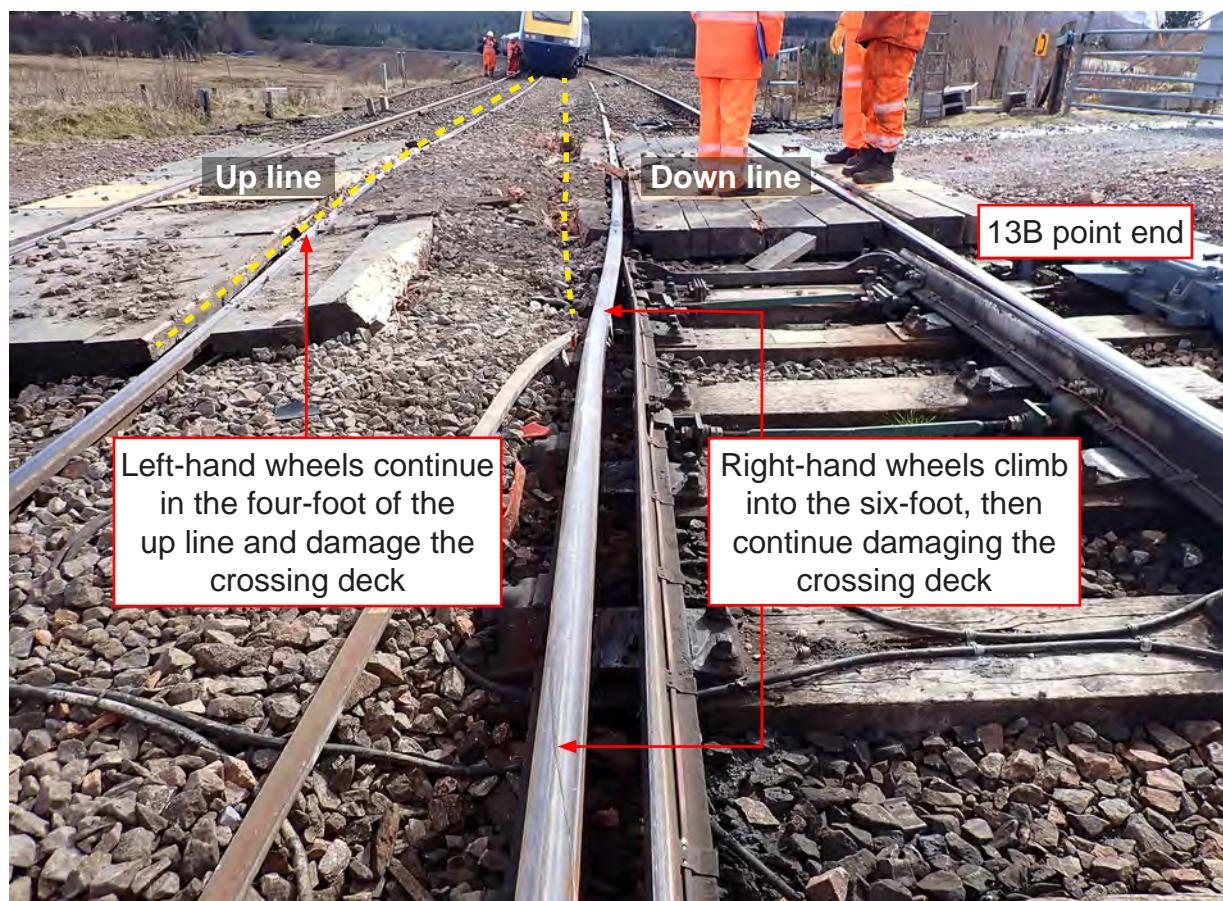

Figure 10: Marks and damage from the last three bogies on the train

### Signal maintenance testing

52 Signal maintenance testing is used when signalling equipment is renewed or replaced on a like-for-like basis without affecting the system application logic.<sup>15</sup> It can include reactive work, such as corrective maintenance or the response to an incident, or pre-planned work, such as minor signalling renewal work. The testing regime is based on the principle that the originally installed equipment was fully tested at commissioning and has been working correctly since. The purpose of the testing is to ensure that work to replace equipment has not affected the safe operation of the signalling system, and that it can be safely handed back into operational service.

53 The requirements for signal maintenance testing are defined in Network Rail company standard NR/L3/SIG/11231 'Signal Maintenance Testing Handbook' (SMTH).<sup>16</sup> They include:

- appointment of a maintenance tester who is in overall charge of the testing; they are to be independent of the installers of the equipment
- testing in accordance with pre-determined test specifications (maintenance test plans)

<sup>15</sup> Application logic is defined in SMTH (see paragraph 53) as 'any technology based method that configures a product so as to provide site specific command and control instructions'; it includes the various kinds of signal interlocking technologies, such as mechanical lever frames and electrical relay-based interlocking.

<sup>16</sup> SMTH has undergone significant re-structuring and revision since the derailment. Unless otherwise stated, references made in the report are to the version current at the time of the point machine replacement at 13B point end.

- checks that the signalling system is compliant with existing infrastructure records (for instance, wiring diagrams) before installation work starts and after it is complete
  - competence of those carrying out the testing
  - the need to complete, return and retain a form (SMTH log sheet) recording the completion of the testing.
- 54 The handbook is divided into parts, each containing separate documents, plans and appendices. Section 9 of SMTH part 02 sets out additional requirements for pre-planned work, and especially states that these apply to the replacement of a point machine. The section includes a flowchart that is to be used to determine which part of SMTH is applicable, or the relevant SWTH module if signal works testing is necessary. The local section manager is responsible for planning the work. This includes:
- identifying the maintenance tester
  - determining the applicable maintenance test plan
  - consideration of the technical information relating to the work
  - briefing the maintenance tester and other staff who are going to be involved beforehand.
- 55 Maintenance test plans for pre-planned work are included in SMTH part 07. Maintenance test plan PC51 'Replace a complete point machine' was applicable to the minor signalling renewal work at 13B point end on 28 June 2020. Like other maintenance test plans, it defines a list of numbered steps that need to be carried out before installation work starts, and a list of steps that need to be carried out after the installation work is completed (figure 11). The steps form a checklist of the minimum tests needed to confirm safe operation. The test plan is relevant to electromechanical and electropneumatic point machines in general, as well as some other types of point control equipment.
- 56 RAIB concluded that the following steps in PC51 were opportunities to have identified the wiring discrepancy found by the signalling failure investigation testing (paragraph 45 and see paragraph 80):
- Step 1 - check that the replacement point machine was the correct type
  - Step 11 - wire count of the newly-installed point machine
  - Step 18 - point detection and correspondence testing of 13 points.
- All three steps refer to defined checks (processes defined in SMTH covering specific signal maintenance-related checks) and defined tests (processes defined in SMTH covering specific signal maintenance-related tests) that are detailed in SMTH part 03.

## BEFORE INSTALLATION WORK

1. Check replacement unit is not damaged and is correct type (internal configurable wiring and straps).
2. [WIRE COUNT](#) existing unit to the wiring diagram.
3. Check existing wiring has safe insulation.
4. Check existing wiring (and hoses for EP machines and chair locks) are correctly labelled.
5. Check replacement controller contacts are in the correct position (matching existing), **(SEPARATE AC POINT CONTROLLER UNITS ONLY)**.
6. Check existing unit is isolated from the electrical supply.
7. Check air supply is disconnected **(ELECTRO-PNEUMATIC MACHINES AND CHAIR LOCKS ONLY)**.

## AFTER INSTALLATION WORK

8. Where any plug coupler is used check that no metallic dust exists between the two halves before reconnecting the plug couplers.
9. Check replacement unit is correctly installed.
10. Check wiring (and hoses for EP machines and chair locks) are replaced as labelled.
11. [WIRE COUNT](#) replacement unit to the wiring diagram.
12. Check any links, and red dome nuts or equivalent, are correctly replaced and secure.
13. Check terminations are secure and suitably protected.
14. Check wires and cables are secure and clear of moving parts.
15. Carry out [NR/SMS/PartB/Test/052](#) (Dynamic Earth Tests) section 1 or 4 depending on whether the points are electronically monitored.
16. Carry out Test [NR/SMS/PartB/Test/011](#) (Electrical Detection Test - Machine) and record the results on the record card, together with the reason for the test **(CHAIR LOCKS, ELECTRIC AND ELECTRO-PNEUMATIC POINT MACHINES ONLY)**.
17. Carry out [NR/SMS/Test/001](#) (FPL Test - Machine) and record the results on the record card, together with the reason for the test **(CHAIR LOCKS, ELECTRIC AND ELECTRO-PNEUMATIC POINT MACHINES ONLY)**.
- \* 18. Carry out a [POINT DETECTION AND CORRESPONDENCE TEST](#) of the affected ends.

Separate AC point controller units shall be treated as a separate affected end for correspondence and detection tests.

**END**

Figure 11: Maintenance test plan PC51 (image courtesy of Network Rail)

### Check for correct type

57 SMTH check A01 'Defined check: check for correct type' contains 'guidelines' for checking that a replacement item of equipment is operationally equivalent to the item being replaced. For internal wiring it states: 'Check that any configurable wiring or straps internal to the replacement item are correct. Check the item is an operational equivalent.'

### Wire count

58 SMTH test B01 'Defined test: wire count' consists of a visual examination to check that the number of wires on each termination point in the equipment correspond to the applicable wiring diagram. A check of the condition of the wiring and terminals is also required.

### Point detection and correspondence

59 SMTH test B08 'Defined test: point detection and correspondence test' consists of the following (carried out in this order):

- point position check – to ensure a correct understanding of the lie of the point ends in their normal and reverse positions
- correspondence test – to ensure that the signal box controls and indications correspond with the lie of the points in the normal and reverse positions
- detection test – to ensure all the contacts in the circuit are effective
- out-of-correspondence test – to ensure that detection cannot be obtained if one or more point ends are not in the correct position.

60 The out-of-correspondence test requires multiple-ended points to be tested systematically with point ends isolated in different permutations, according to a permutation chart (see table 2 for an example permutation chart that covers two point ends). The signalling failure investigation testing carried out post-derailment included an out-of-correspondence test. It showed that a correctly executed out-of-correspondence test should have revealed the wiring discrepancy when the point machine was installed.

No.	End A	End B	Tick
01	0	0	
02	0	1	
03	1	0	

Table 2: Permutation chart for two point ends (0 denotes point end isolated)

### Signalling maintenance

61 Network Rail company standard NR/L3/SIG/10663 'Signal Maintenance Specifications' (SMS) gives information on the need to maintain signalling equipment. It includes:

- general maintenance responsibilities and conditions
- approved maintenance specifications for signalling, telecom and other assets that are maintained by signalling maintenance teams
- specified tests referred to in the maintenance specifications.

- 62 Some of the specified tests, such as the facing point lock (step 17 in PC51) and detection tests, are referred to in SMTH documents.

### Signalling installation

- 63 Network Rail company standard NR/L3/SIG/11303<sup>17</sup> 'Work instruction, signalling installation' includes installation requirements for systems and equipment, and is applicable to both signalling works and signalling maintenance teams. Installation staff are required to follow this standard unless alternatives are specified in other standards or approved as superior by the responsible signalling project engineer. Elsewhere, it requires that:
- installation work is subject to supervision, quality checks and audit to ensure approved work methods are followed, and required standards of workmanship are achieved
  - equipment to be installed is of the correct type and is correctly configured.
- 64 For signalling maintenance work, including like-for-like equipment replacement, NR/L3/SIG/11303 states that reference also needs to be made to 'appropriate maintenance standards and Signal Maintenance Testing standards.' No further detail is provided on how it relates to the maintenance standards that are considered applicable and there is no reference to specific documents, such as SMTH or SMS. For work requiring signal works testing, it identifies SWTH as the related standard.

### Applicable Network Rail competency management standards

- 65 Two company standards describe Network Rail's general processes for ensuring the adequate competency of individuals carrying out engineering work on signalling equipment:
- NR/L2/CTM/012 'Competence and training in signal engineering' sets out Network Rail's authority to work arrangements for the various activities carried out on signalling equipment.
  - NR/L2/SIG/10160 'Specification for application of the IRSE licensing scheme' describes the requirements for staff to hold the relevant licence issued by the Institution of Railway Signal Engineers (IRSE).
- 66 Additional competency requirements are included in SWTH for staff that carry out signal works testing.

### Network Rail authority to work arrangements

- 67 NR/L2/CTM/012 defines the minimum requirements for the training and assessment of staff that carry out work on signalling equipment. It defines a set of defined competencies (competency modules), each relating to an activity or type of signalling equipment. The listed competency modules relevant to the maintenance, installation, and signal maintenance testing of electromechanical point machines include:
- module 'Sig 10' – corrective and preventative maintenance of electro-mechanical point machines
  - module 'Sig 31' – installation and adjustment of electromechanical type point operating systems

<sup>17</sup> NR/L3/SIG/11303 was previously known as the signalling installation handbook (SIH).

- module ‘Sig 44’ – confirmation that signalling systems have been tested to SMTH requirements following maintenance, defect repair or renewal (module ‘Sig 44’ is more commonly referred to as module ‘SMTH’).
- 68 Separate competency standards define the assessment requirements and other information relating to each competency module. These include the scope (work activity and equipment type covered), the knowledge required and the performance to be demonstrated.
- 69 Network Rail maintains a record of the competency modules held by an individual, any restrictions that apply and the work activities that the person is authorised to complete.

### *Institution of Railway Signal Engineers licensing scheme*

- 70 The IRSE licensing scheme is run by a licensing committee within the IRSE. The licences, which are issued independently of Network Rail, cover a broad range of signalling engineering disciplines. Different licence categories apply according to the work activity involved. NR/L2/SIG/10160<sup>18</sup> lists the licence categories identified as appropriate to signalling maintenance, minor signalling renewals,<sup>19</sup> and signal maintenance testing. They include:
- licence 1.4.230 – signalling maintainer and fault finder
  - licence 1.2.220 – signalling installation technician
  - licence 1.4.160 – signalling maintenance tester.
- 71 NR/L2/SIG/10160 requires that individuals hold the relevant IRSE licence if they are responsible for safety-critical work. The minor signalling renewal work at 13B point end was classed as such.<sup>20</sup>
- 72 To gain an IRSE licence, applicants need to:
- have been regularly employed on work relevant to the licence category
  - maintain a logbook of training, learning and competence assessments, and relevant work experience
  - be assessed against requirements in the IRSE competence standard relevant to the licence category.
- 73 NR/L2/SIG/10160 includes some flexibility and allows an individual to be responsible for safety-critical work that is outside of that covered by the IRSE licence they hold for their normal work, otherwise referred to as ‘secondary activity’ work. However, individuals can only be responsible for such work if their employer (Network Rail in this case) deems them suitably competent to undertake that type of work (see paragraph 168).

<sup>18</sup> Reference is made to the requirements in Issue 3 which was issued in December 2020. Issue 2 was issued in September 2011. Although this was the issue that was current at the time of the 13B point end renewal work, the listed IRSE licence categories were out of date. Issue 3 was the result of a review and clarification of Issue 2.

<sup>19</sup> NR/L2/SIG/10160 refers to the installation of ‘...signalling equipment as part of Minor Works...’

<sup>20</sup> In accordance with Railways and Other Guided Transport Systems (Safety) Regulations 2006.



## Analysis

### Identification of the immediate cause

- 74 The signaller was able to clear DW3 signal, permitting train 5S85 to approach 13 points when they were in an unsafe condition.**
- 75 The signaller at Dalwhinnie had commanded 13 points to the normal position after the train had safely passed the crossover on its earlier northbound journey to Tomatin. The signaller had obtained the correct indications for this in the signal box (paragraph 40). The signalling data logger recorded that the normal detection relay for 13 points (13NWKR, see appendix B) energised at this time. With this relay energised, the interlocking did not prevent the signaller being able to clear DW3 signal when the train returned on its journey south (paragraph 42).
- 76 The fact that the leading power car and coaches were wrongly diverted onto the crossover and the down line (paragraphs 43 and 47) showed that 13 points were not in a safe condition and that the clearing of DW3 signal by the signaller should not have been possible. For the train to be diverted, the left-hand switch rail at the 13A point end needed to be close to the stock rail. Taking into account the way that the point machine at 13B point end was found to be wired (see paragraph 80) and that the 13NWKR detection relay continued to be energised, RAIB has concluded that the switch rail was close to being adjacent to the stock rail, and certainly close enough to have been detected as being in the (full) reverse position. This conclusion is consistent with the lack of damage on the toe of the left-hand switch rail (paragraph 48).
- 77 A combined analysis of the OTDR and the signalling data logger showed that the 13NWKR detection relay de-energised as the leading wheels passed over the 13B point end. This observation, and the damage to the track (paragraph 47), is consistent with the switch rails being in the (correct) normal position at the 13B point end when the wheels approached, with the switch rails deforming as the train's wheels ran through in the trailing direction. As a result, the point machine at 13B point end started to detect that the switch rails at this end were no longer in the normal position.
- 78 The combined analysis also showed that the loss of normal detection in the 13B point end occurred around two seconds before the wheels on the trailing bogie on the sixth vehicle (coach E) approached the 13A point end, but after the leading bogie of this vehicle had passed this point end. The circuitry for 13 points was designed so that each point machine would attempt to move its set of switch rails back to their commanded position if detection was lost (see appendix B). The signalling data logger showed that it had previously taken around three seconds for the point machines at 13 points to fully move the switch rails from the reverse position to the normal position, which was the position they had been commanded by the signaller. Together, this explains how and why the switch rails at 13A point end moved as train 5S85 passed over them and that the wheels on the last three bogies of the train encountered them in their mid-position, derailing as a result (paragraph 48).

- 79 There are a variety of reasons that would explain why the switch rails at the 13A point end did not move away from the reverse position, on this occasion, when the signaller commanded 13 points to the normal position (paragraph 76). The lack of movement resulted in the switch rails at the two point ends being in opposite positions (out-of-correspondence) and, therefore, 13 points being unsafe. Such point failures are not uncommon and are generally viewed as a performance or reliability concern. Operational safety is assured by the signalling system detecting the position of the switch rails and, if incorrect, preventing the signaller from being able to clear the relevant signal. As a result, RAIB's investigation has focussed on the failure of the detection system.
- 80 The detection system failure is fully explained by the wiring discrepancy that was discovered in the 13B point machine during the signal failure investigation testing (paragraph 45). This testing found two electrical conductors on the terminals of the point machine detector unit that were not shown on the 13B point end wiring diagram. These were (figure 12):
- a metal link (link) connecting terminals C1 and C2
  - a strap termination (strap) connecting terminals C8 and D2.
- 81 With these additional conductors in place, out-of-correspondence testing and circuit analysis (see appendix B) showed that normal detection was incorrectly obtained (detection relay 13NWKR energised) when the switch rails at the 13A point end were in the reverse position and switch rails at the 13B point end were in the normal position. As designed (without these additional conductors), the detection circuits would have detected that 13 points were out of correspondence (detection relay 13NWKR not energised).
- 82 RAIB has concluded that the additional conductors (the link and the strap) were a part of the internal wiring of the reserviced point machine that was supplied to the depot in Inverness. These conductors are needed so that the detection circuitry functions correctly when GRS 5E type point machines are installed at single-ended point locations. Apart from Dalwhinnie, GRS 5E type point machines are only installed at single-ended point locations on the Highland main line, and witness evidence from staff in Inverness depot was that all recently reserviced GRS 5E type point machines had been supplied with wiring that was compatible with single-ended usage.
- 83 The internal detection circuit wiring in the installed point machine directly matched that on the wiring diagram for a single-ended point location on the Highland main line that was considered typical (Tomatin passing loop), and that the only other wires connected to the detection terminals were the cores of the external tail cables. RAIB found no evidence of any routine maintenance or other work that would have altered detection circuit wiring after the 13B point machine was installed and before the derailment.

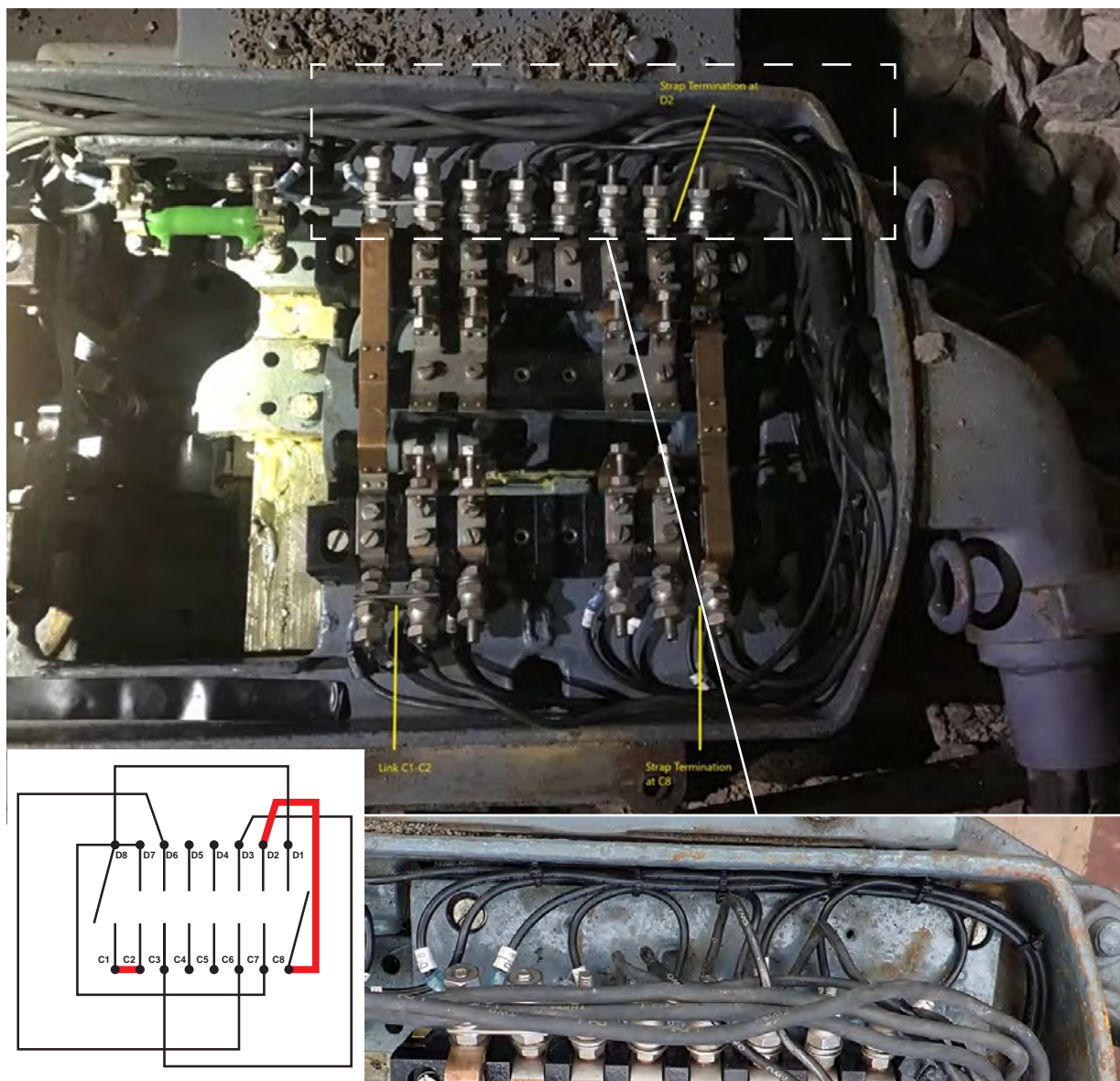

Figure 12: Additional link and wire strap (red) found in point machine at 13B point end (main photograph courtesy of Network Rail – annotation Network Rail). Inset photograph below shows example of use of cable ties to bind wires

## Identification of causal factors

84 In terms of detection circuitry, the resericed point machine would have been suitable for the replacement of any GRS 5E point machine on the Highland main line, apart from at 13 points at Dalwhinnie. 13 points differed in that they were double-ended, with a points position detection circuit that was shared by the two point ends. This meant that the additional conductors (the link and the strap) needed to be removed for correct installation at this location. There were four opportunities for the presence of these conductors to have been detected during the installation and test process. These were during:

- renewal planning
- pre-installation checks

- post-installation wire count
  - out-of-correspondence testing, as part of the final commissioning tests.
- 85 The additional conductors were not identified as part of any of these activities. The reasons why are discussed below.

### Renewal planning

**86 Renewal planning activity did not identify the need to alter the internal wiring in the reserviced point machine possibly because technical information that may have been relevant was either not reviewed or was not available.**

87 The Inverness section manager and the Inverness section supervisor planned to test and commission the replaced point machine at 13B point end using processes defined in SMTH (paragraphs 52 and 53). As a minor signalling renewal, it was pre-planned work and the planning requirements in section 9 of SMTH part 02 applied. These included the need to consider technical information relating to the work (paragraph 54).

- 88 Some of the technical information that is listed in section 9 of SMTH part 02 offered the possibility of identifying the wiring discrepancy:
- the wiring diagrams for 13 points could have revealed the differences in the detection circuits used; alternatively, they could have highlighted that the detection circuits for 13 points were atypical, and that extra care was needed
  - certificates of conformity for the replacement point machine could have included consideration of product information leading to an understanding that wiring alteration was needed; the consideration of other types of product information<sup>21</sup> may have led to a similar understanding.

The allocated renewal team understood the need to reconfigure the supplied point machine if its hand of operation was incorrect (paragraph 31). However, they did not expect to need to alter the internal wiring for the detection circuits.

- 89 None of this technical information was considered when the renewal work was planned, because:
- a. The section supervisor did not understand that he was supposed to consider listed technical information as part of the planning process. This is a possible factor (see paragraph 90).
  - b. No product information was made available to the Network Rail signalling engineering team that described how the internal wiring in the reserviced point machine was configured or that it was necessary to check if alteration was needed. This is a possible factor (see paragraph 95).

<sup>21</sup> SMTH part 02 states that the list of technical information is not exhaustive and that other items of information 'are to be added if appropriate for the work.'

### Planning process - understanding

**90 The section supervisor did not understand that he was supposed to consider listed technical information as part of the planning process. This is a possible factor.**

- 91 Most of the planning was done by the Inverness section supervisor working on behalf of the Inverness section manager. He was familiar with arranging minor signalling renewals of this type and planned the point machine replacement at 13B point end in accordance with his normal practice. The planning steps included:
- allocating signalling maintenance staff to the CapEx work, notifying them of the overtime shift and appointing the maintenance tester (paragraph 24)
  - identifying the maintenance test plan to be used (paragraph 55)
  - preparing the maintenance test plan list that was to be taken to site (paragraph 28)
  - ensuring the arrangement of the safe system of work (paragraph 28).
- 92 The planning steps that were followed were largely consistent with the planning process defined in section 9 of SMTH part 02. However, because the Inverness section supervisor was unaware of the planning process and its requirements, he gave no consideration to reviewing relevant technical information, such as the wiring diagrams for 13 points, nor did he brief the requirements of the planned work to the maintenance tester and installation team (paragraph 54).
- 93 The wiring diagrams for 13 points were information that would have been available. However, the Inverness section supervisor did not see the need to obtain or review copies in advance because prints were available in the location case for the renewal team to consult on site. RAIB found evidence of general acceptance of this practice within Network Rail's signalling engineering organisation, so long as it was known that the site wiring diagrams were in good condition.
- 94 The planning process in section 9 of SMTH part 02 also included the need to provide permutation charts (paragraph 60). These charts could have served as a reminder to complete the out-of-correspondence testing that was required (see paragraph 136). No such charts were provided (see paragraph 148).

### Point machine product information

**95 No product information was made available to the Network Rail signalling engineering team that described how the internal wiring in the reserviced point machine was configured or that it was necessary to check if alteration was needed. This is a possible factor.**

- 96 Supporting product information could have alerted those planning the renewal work to relevant restrictions and precautions, and then led to the renewal team then being briefed and informed that alteration was necessary. Product information could also have been a means by which the renewal team were directly informed.
- 97 RAIB found no evidence that relevant product information was made available through processes used for product acceptance, product information management, procurement, delivery, and product labelling.

- 98 Network Rail company standard NR/L2/RSE/100/05 'Product acceptance and change to Network Rail operational infrastructure' defines the process that Network Rail uses to ensure products are safe, compatible, and fit for purpose for use on its infrastructure. Products accepted under this standard are issued with a product acceptance certificate that is required to include a product description, and also configuration and application details. Point machines are generally covered by this standard. However, this type of point machine had been reserviced and used on the national network since before railway privatisation in the mid-1990s and Network Rail had granted it historic approval rights (formerly known as 'grandfather rights'). This meant that no product acceptance certificate was required or issued.
- 99 In common with other UK rail companies, the depot team in Inverness used a national industry database to search for information on components and equipment they planned to install. Information on the GRS 5E type point machine is listed under a single catalogue number (088/813010); there are no product variants. There is a short technical description of the point machine under this catalogue number, but no information relating to its configuration or use. The point machine is also listed in Unipart Rail's own catalogue. Again, there is only one catalogue number and no configuration detail is provided.
- 100 The depot team in Inverness ordered reserviced GRS 5E type point machines from Unipart Rail by using Network Rail's central online purchasing system, again by reference to the relevant catalogue number. A free text field was available when ordering. This was typically used to state if the reserviced point machine was to be supplied for left-hand or right-hand operation. There was no other means to specify how the point machine was to be configured.
- 101 The GRS 5E type point machine fitted to 13B point end was reserviced at Unipart Rail's signalling workshop in York.<sup>22</sup> Network Rail was unable to provide information on how it expected the internal wiring to be configured.
- 102 Network Rail provided a copy of the documentation accompanying the delivery of reserviced GRS 5E point machines to the Inverness depot. This documentation mainly related to billing and shipping information and included neither a supporting certificate of conformance nor any technical information concerning configuration, application or use restrictions.
- 103 Unipart Rail fitted a small information plate to the inside of the point machine at 13B point end and a label to the outside cover. The plate recorded where and when the point machine was reserviced ('York 2020'). No label (or other device) was fitted to alert the renewal team of application or use restrictions.

---

<sup>22</sup> Unipart Rail has recently decided to close the workshop in York and to no longer reservice this type of point machine.

## Pre-installation checks

### **104 The pre-installation checks in the specified maintenance test plan did not identify the need to alter the internal wiring in the resericed point machine.**

105 Step 1 of maintenance test plan PC51 required the maintenance tester to check that the replacement point machine was the correct type (figure 11) and places emphasis on the internal wiring:

- ‘Check that replacement unit is not damaged and is correct type (internal configurable wiring and straps)’.

This was an opportunity to discover the wiring discrepancy before the point machine was installed at 13B point end.

106 The maintenance tester was aware that installer A had unloaded the replacement point machine and had checked inside (paragraph 32). The maintenance tester was helping with mechanical disconnection of the existing point machine at the time but had seen the work installer A had been doing. The checks that installer A made were against the site wiring diagrams. He confirmed this to the maintenance tester. The maintenance tester concluded that the work installer A had done met the requirement of step 1.

107 Step 1 equates to a defined check that is detailed in SMTH part 03 (paragraphs 56 and 57). While SMTH part 03 states that defined tests, which are also detailed in this part of SMTH, shall only be undertaken by maintenance testers (or under their supervision), it does not state if the same restriction applies to defined checks.

108 Neither the maintenance tester, nor anyone else, had asked installer A to check the internal wiring. Installer A was unaware of any related formal process he was required to follow in his role as an installer and did not know of a related installation manual. Instead, he relied on his own knowledge and experience. Installer A held Network Rail’s SMTH competence module (paragraph 67) and had been the maintenance tester on other GRS 5E type point machine renewals. Witness evidence indicated that his intention was to carry out checking work that was consistent with the requirement of step 1 of maintenance test plan PC51.<sup>23</sup>

109 This causal factor arose due to a combination of the following:

- a. The pre-installation checks carried out by installer A did not identify the wiring discrepancy, possibly because of weaknesses in their definition and how they were executed (see paragraph 110).
- b. The maintenance tester did not verify or challenge the checks carried out by installer A. This is a possible factor (see paragraph 115).

Each of these factors is now considered in turn.

<sup>23</sup> The step-by-step process in module 2S10 of NR/L3/SIG/11303 (see paragraph 158) requires installers to confirm that the internal wiring complies with the relevant wiring diagram.

Installer's actions**110 The pre-installation checks carried out by installer A did not identify the wiring discrepancy, possibly because of weaknesses in their definition and how they were executed.**

111 Installer A was unable to explain why the checks that he made did not identify the wiring discrepancy. One possibility was that he incorrectly referred to the wiring diagram for 13A point end. This is because there is little to distinguish between the annotation used to identify the point ends on the respective drawings. However, while the unwanted link and strap were shown on the 13A point end wiring diagram, other wiring differences should have been identified. Another possibility, supported by witness evidence, was that it was raining at the time and that this affected his concentration (paragraph 26).

112 The manner and degree to which information relating to the defined check in step 1 of test plan PC51 was referenced, relevant and made available to the installer may also have compromised the effectiveness of the checking work:

a. Reference to defined checks

The distinctive referencing of supporting information on tests, checks and other tasks is widely adopted in Network Rail signalling standards. In maintenance test plan PC51, capital letters and hypertext are used when referring to the wire count defined test (SMTH test B01). In the equivalent signal works testing document, NR/L2/30014/D120/T26-21 'Point machine signalling works testing specification', a similar convention is used to reference supporting information on defined checks. Figure 13 shows extracts.

No such convention is used to emphasise the defined check for correct type (SMTH check A01) in step 1 and link the supporting information. A convention of this type would have better highlighted the significance and importance of step 1 and made the supporting information easier to refer to. It is possible that this would have more firmly seated relevant information in the minds of those, such as installer A, who regularly use and follow this maintenance test plan.

b. Relevance of the internal wiring check

SMTH check A01 requires that 'configurable wiring and straps' are checked as being correct (paragraph 57). All of the detection circuit wiring in the replacement point machine was of the same type and colour (black) and was tightly bound with cable ties (figure 12). The individual wires had no identification marks, labels, or other devices that drew attention to the fact that they should be treated as being 'configurable', and therefore the subject of the defined check. The way in which the wiring had been fitted may have suggested to installer A that this wiring was an integral part of the point machine that should not be altered or tampered with.

As written, SMTH check A01 may be read as suggesting that a simple visual examination of the internal wires is all that is required. According to witness evidence from those involved, fully tracing and correlating each wire to the wiring diagram would mean the removal of the cable ties and the separation of the individual wires. SMTH check A01 does not mandate this, or an activity that is equivalent. RAIB found no evidence, following the derailment, that cable ties had been removed or replaced.



## c. Access to SMTH information on site

Signalling engineering staff at Inverness relied on tablet computers to access SMTH and other process information when on site. Installer A explained that there are difficulties using tablet computers in wet weather. Because it was raining, he had left his computer tablet in his vehicle and others had done the same. It left them depending on their knowledge and memory when determining what they needed to do.

## Maintenance test plan

NR/L3/SIG/11231 Signal Maintenance Testing Handbook		
<b>NR/SMTH/Part07/PC51</b>		
<b>Replace a Complete Point Machine</b>		
Issue No: 03	Issue Date: 05/12/2020	Compliance Date: 05/06/2021

<b>Includes:</b>	Electric and electro–pneumatic point machines, Chair locks, Separate AC point controller units
<b>Excludes:</b>	Any other type of point operating equipment (POE)

### BEFORE INSTALLATION WORK

1. Check replacement unit is not damaged and is correct type (internal configurable wiring and straps).
2. [WIRE COUNT](#) existing unit to the wiring diagram.
3. Check existing wiring has safe insulation.
4. Check existing wiring (and hoses for EP machines and chair locks) are correctly labelled.

## Signalling works testing specification



OFFICIAL

NR/L2/SIG/30014/D120/TS6-21

Issue: 04  
Date: 05/06/2021  
Page: 2 of 7

### Point Machine Signalling Works Testing Specification

#### NOTES:

General definitions of terms are given in [E110](#), terms specific to this specification are defined in Table 1 at the end of this Test Specification.

#### 1. INSPECTION

- 1.1. Review Handover Certificate(s) or, where not provided, complete the Certificate(s) as far as possible without disarranging the points.
- 1.2. *CHECK FOR CORRECT TYPE* ([D115/DT1-01](#)).
- 1.3. *CHECK FOR NO DAMAGE* ([D115/DT1-02](#)).
- 1.4. *CHECK FOR CORRECT POSITION*

Figure 13: Extracts from maintenance test plan PC51 and point machine signalling works testing specification showing the referencing used to support test and checking information (images courtesy of Network Rail)

- 113 The pre-installation checks could have been carried out earlier in a more suitable location, such as a workshop or other technical room at Inverness depot. Shelter and having tools, equipment and information to hand would have made the checking work easier and potentially more robust. There would also have been more time to manage and resolve arising issues and concerns. Section 9 of SMTH part 02 includes 'pre-testing' on the list of technical information to be considered during planning (paragraph 92).
- 114 The availability of relevant product information would also have made the checking easier and potentially more robust (paragraph 95).

#### Maintenance tester's actions

#### **115 The maintenance tester did not verify the checks carried out by installer A. This is a possible factor.**

- 116 The maintenance tester knew installer A was suitably experienced and was competent to carry out the checks in step 1 of maintenance test plan PC51. The maintenance tester felt he could rely on installer A and did not believe it was necessary to repeat or challenge the checking work done. In the maintenance tester's experience, it was common for maintenance testers to accept evidence from the work done by installers.
- 117 Even if the maintenance tester had endeavoured to verify the checks undertaken by installer A, he may not have necessarily identified the wiring discrepancy. This is due to similar reasons to those described in paragraph 112.
- 118 RAIB has identified a lack of clarity in Network Rail's definition of the working arrangements between maintenance testers and installers as a probable underlying factor (see paragraph 153).

#### Post-installation wire count

#### **119 The post-installation wire count in the specified maintenance test plan did not identify the differences between the detection circuit wiring in the newly-installed point machine and the site wiring diagram.**

- 120 Step 11 of maintenance test plan PC51 (figure 11) required the maintenance tester to carry out a wire count after the replacement point machine had been installed. This was to confirm that the number of wires (and conductors) connected to each terminal point corresponded to those on the wiring diagram (paragraph 58). A correctly executed wire count would have revealed the wiring discrepancy before 13 points were placed back into service.
- 121 The maintenance tester was present when installer A and installer B transferred the tail cables and made the electrical connections onto the replacement machine (paragraph 33).
- 122 The wire count in step 11 is a defined test: SMTH test B01. As such, it should 'only be undertaken by, or under the supervision of, maintenance testers' (paragraph 107). Installer A was at the point machine making the connections and checking the terminals. The maintenance tester was nearby reading the wiring diagram, and providing installer A with information so that installer A could count and confirm what wires were connected. The maintenance tester concluded that, in combination with the pre-installation checks, sufficient work had been done to complete step 11 and that he did not need to carry out another wire count himself.

123 This causal factor arose due to a combination of the following:

- a. The wire count carried out by installer A did not cover the full scope of that required by the maintenance test plan (see paragraph 124).
- b. The maintenance tester incorrectly assumed that the work that installer A carried out meant that the full scope of the required wire count had been covered (see paragraph 128).
- c. The maintenance tester did not separately verify that the wire count had covered the full scope required by the maintenance test plan (see paragraph 132).

Each of these factors is now considered in turn.

#### Wire count – installer’s actions

### **124 The wire count carried out by installer A did not cover the full scope of that required by the maintenance test plan.**

125 Installer A did not intend or believe that the checks he was making when transferring the tail cables were to complete step 11 of maintenance test plan PC51. RAIB found no evidence that installer A had been asked to complete that wire count.

126 Staff at the Inverness depot had developed an approach to detaching the tail cables on GRS 5E type point machines that involved unbolting the gland (the metal casting through which external wires enter the point machine case) and removing it with the tail cables intact. This avoided the need to rethread the tail cables through the gland on the reserviced point machine. It also simplified the connection of the individual tail cable wires on to the reserviced point machine. The distorted shape of the tail cables meant that each wire approximately aligned with the terminal onto which it needed to be connected.

127 The condition of the gland shown on the photograph of the newly-installed point machine is consistent with the tail cables having been transferred in this way (figure 14). Witness evidence supports both this, and that installer A’s focus did not extend to considering the internal detection circuit wiring. He had not considered this necessary because of the pre-installation checking work that he had done (paragraph 106).

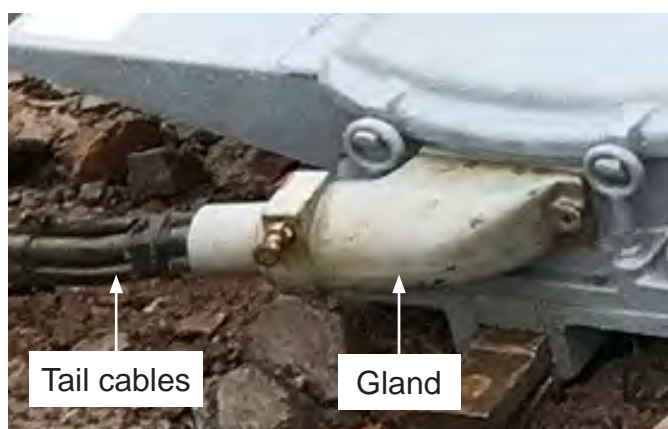

*Figure 14: Enlargement of figure 8 showing the tail cables and gland. Paint discolouration is evidence that the gland is from the point machine that was replaced (photograph courtesy of Network Rail)*

Wire count - maintenance tester's conclusions

**128 The maintenance tester incorrectly assumed that the work that installer A carried out meant that the full scope of the required wire count had been covered.**

129 The maintenance tester had concluded that:

- the pre-installation checking work had covered step 1 of maintenance test plan PC51 (paragraph 106) and, therefore, that the point machine internal wiring was correct
- the checks he had witnessed installer A doing when the tail cables were transferred (paragraph 122) meant that the external wiring connections were correct.

However, the inadequacies with the pre-installation checks (paragraph 110) meant that the full scope of the wire count had not been covered.

130 No record was made of the wire count. Standard methods for recording a wire count include ticking or marking a copy of the wiring diagram, or completing a wire count grid sheet. Issue 06 of SMTH test B01 (7 March 2020) was current at the time of renewal. It included guidance stating that a wire count 'can be recorded if it assists the maintenance tester', and that a 'wire count grid sheet is suitable for this purpose'. However, there was no mandate for this. The test requirements specifically stated that 'It is NOT necessary to record the wire count for auditing purposes, i.e. by ticking the wiring diagrams'. Making a record of the wire count would have helped the maintenance tester appreciate that the wire count work was incomplete.

131 SMTH test B01 was revised shortly after the point machine was replaced (issue 07, dated 5 December 2020) to require that 'All wire counts shall be recorded using a wire count grid sheet'.

Wire count - verification

**132 The maintenance tester did not separately verify that the wire count had covered the full scope required by the maintenance test plan.**

133 The maintenance tester had drawn conclusions (paragraph 129) that had led him to believe that the wire count in step 11 had been covered by work that installer A had done. He did not believe it was necessary to verify the work that installer A had done by completing a wire count himself. Again, the maintenance tester knew that installer A was suitably experienced, and he felt that the work he had done could be relied on.

134 The maintenance tester was one of the most experienced members of staff in the Inverness depot and held the SMTH competency module that Network Rail required. However, the maintenance tester had only recently started doing overtime shifts and he had not worked on many minor signalling renewals involving the replacement of GRS 5E point machines. In fact, this was the first time he had been the maintenance tester on pre-planned equipment replacement work like this. Installer A had more recent experience of the replacement of GRS 5E point machines, in both the maintenance tester and installer roles. It is possible this may have given the maintenance tester additional confidence in the work that installer A had done.

135 RAIB found evidence suggesting it was common for maintenance testers to accept evidence from the work done by installers (paragraph 116). RAIB has identified a lack of clarity in Network Rail's definition of the working arrangements between maintenance testers and installers as a probable underlying factor (see paragraph 153).

### Out-of-correspondence testing

#### **136 The maintenance tester did not complete the specified out-of-correspondence testing following installation of the reserviced point machine.**

137 Step 18 of maintenance test plan PC51 (figure 11) required the maintenance tester to complete an out-of-correspondence test as part of SMTH test B08 (paragraphs 59 and 60). This was the last opportunity to identify the wiring discrepancy before handing 13 points back into service.

138 The maintenance tester originally anticipated completing step 18 (and other remaining tests) by returning to 13 points after needing to stop and wait for the signaller to arrive on duty (paragraph 34). When back at the points, his plan was to collaborate with the signaller by mobile telephone. However, he eventually decided he could wait no longer and that he needed to go to the signal box instead. Although the signaller had only just arrived, the maintenance tester was able to ask them to operate 13 points for him. However, the maintenance tester was then drawn to a series of unrelated actions, and he completed neither the out-of-correspondence testing nor any of the other tests that were outstanding (paragraphs 36 and 37).

139 Although it is likely that the maintenance tester had intended to carry out step 18, RAIB has concluded that the need to wait for the signaller, and the actions he was then drawn to, was an interruption that resulted in him not reorientating to the original task of following the maintenance test plan, and thereby not completing the out-of-correspondence test. Human errors resulting from interruptions are not unusual. This helps further explain why the maintenance tester went on to believe that the testing was complete and why he started to fill in the SMTH log sheet. This recorded that 13 points were assessed as safe for operational service.

140 An interruption can be considered to have occurred when:

- a second task is involved (in this case the need to stop and replan because the signaller was not there when they were first called) that leads to the suspension of the original task (the SMTH testing)
- the second task involves decision-making and captures the attention of the individual
- the individual needs to retain information about the original task so that they can return to it (reorientate to the original task).

RAIB found a variety of evidence supporting that the interruption had likely captured the maintenance tester's attention and reasons for him not re-orientating correctly (see paragraphs 142 to 150). Figure 15 shows a timeline which summarises the relevant actions, and how they relate.

141 The relevance of other individual factors is discussed in paragraphs 151 to 152.

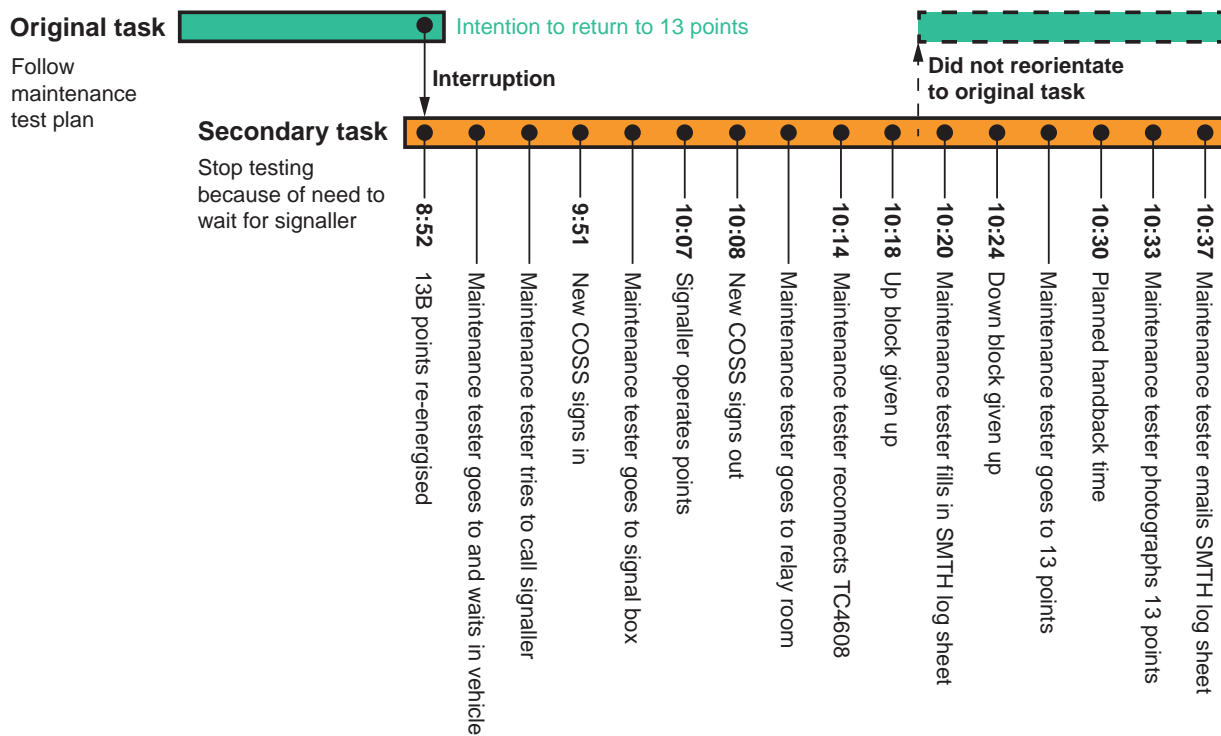

Figure 15: Timeline of events relating to the renewal of the 13B point machine and the interruption resulting from the need to wait for the signaller to book on duty

### Suspension of original task, attention capture and decision-making

- 142 The maintenance tester's attention would have been first captured when he was waiting for the signaller, and by his attempts to get in contact with them. It is likely that his attention was next captured by his other duties; he was also COSS, protection controller and PIC.
- 143 The maintenance tester believed he needed to hand back the line at 10:30 hrs (paragraph 29) and that train 1E17 was due shortly thereafter (paragraph 28). His attention would have next been captured by his perception of the increasing urgency of the need to give up the line blockages, and to go to the relay room to reconnect the track circuits (paragraph 29).
- 144 The need to sign another COSS into the line blockages would also have captured his attention (paragraph 35). This would have been exacerbated by the need to sign the COSS out before he could hand the line blockages back. Records show the COSS was only signed in for 17 minutes (paragraph 36).
- 145 These tasks would have also placed demands on his decision-making as he tried to determine what he needed to do, and when. In fact, the maintenance tester had much more time than he thought. Train 1E17 was scheduled to pass Dalwhinnie at 10:51 hrs. However, timetable changes meant that this train did not run. The first train that day was train 1B52, the 10:53 hrs departure from Inverness to Edinburgh Waverley. The signalling data logger recorded it passing Dalwhinnie at 11:55 hrs.

### Lack of reorientation to original task

- 146 The maintenance tester would probably have had to give more thought than was normal to recalling the current status of the test work because he had neither been completing all the testing himself (paragraphs 106 and 122), nor had he been keeping a record of what had been done. While waiting for the signaller, he specifically remembered trying to recall the testing that still needed doing.
- 147 The SMTH log sheet (paragraph 53)<sup>24</sup> includes a set of boxes that the maintenance tester is required to tick to record test completion. There is one box for each step on the maintenance test plan. In accordance with Appendix C of SMTH part 02, the maintenance tester should have recorded progress by ticking off the boxes one at a time as the test plan steps were completed. However, he decided to fill in the SMTH log sheet in a single sitting, either during, or immediately after, handing back the line blockages. It had been raining and the dry and pristine condition of the SMTH log sheet (figure 6) is consistent with this being done somewhere sheltered, such as the relay room or inside a vehicle. It is possible that the poor weather contributed to this decision.
- 148 The need in SMTH part 02 to provide permutation charts when planning pre-planned work (paragraph 94) was introduced in March 2018. This relatively recent requirement was briefed to the Perth S&TME at that time and was cascaded to the Inverness section manager, but the practice was not implemented locally. It was most likely overlooked because it was one of around 400 other changes in the brief. The brief also incorrectly referred to 'Part 2' (section 2) of SMTH part 02, whereas the change was to section 9 (figure 16). Furthermore, at the time of the renewal, the use of permutation charts was not mandated in the applicable testing standard (SMTH test B08). This standard only required that an out-of-correspondence test was to be recorded 'to assist' the maintenance tester and that a permutation chart was 'suitable for this purpose'.<sup>25</sup>
- 149 The maintenance tester was not at 13 points when he finally completed the SMTH log sheet. Although the time recorded on the SMTH log sheet (10:20 hrs) suggests the maintenance tester was in the relay room,<sup>26</sup> his recollection was that it was when he was back in a vehicle, which would have been slightly later. Both are consistent with the dry condition of the document. In either case, this was not where the maintenance tester had intended and needed to be when completing maintenance test plan PC51 (paragraph 138).
- 150 The maintenance tester filled in the SMTH log sheet on completion of the work believing that all the maintenance test plan steps were complete. He explained that he had visited Dalwhinnie on a number of occasions afterwards and would have had the opportunity to redo the testing if he had had any doubts about its completeness. Being distant from 13 points when the sheet was completed may have deprived the maintenance tester of the normal cues which guide completion of the sheet, and it is possible this contributed to a belief that all the testing had been undertaken.

<sup>24</sup> The SMTH log sheet is a generic form that needs to be configured for the specific maintenance test plan(s) being followed. Maintenance testers are issued with a supply of these forms.

<sup>25</sup> SMTH test B08 was revised after the point machine was replaced (issue 08, 4 September 2021); it now states that 'permutation grid sheets are provided for this purpose'.

<sup>26</sup> Between the times that the down and up line track circuits were reconnected, 10:14 hrs and 10:24 hrs respectively.

## Signal standards brief (March 2018)

### General Amendments: SMTH

(1)



#### Changes:

##### Part 2 Part 02 Introduction and Overview.

The requirement for a permutation chart to be provided at the pre planning stage (if required) has been added.

##### Part 3 B05 Defined Test: Earth Test (DC up to a nominal 120V).

Has been amended to ensure consistency between the SMS and SMTH with regard to Earth faults.

##### Part 3 Check A01 - Defined Check - Check for Correct Type.

A requirement to verify the replacement shelf relay type is the correct type before attaching a Remax top has been added

##### Part 3 Test B20 - Defined Test TPWS Module or Transmitter Loop

A requirement has been added to check the diagram for the correct links, following feed back from Training Centres.

##### Part 3 Test B21 - Defined Test TPWS Remove and Refit Test And

##### Part 3 Test B22 - Defined Test TPWS Self-Powered OSS (SPOSS) Trackside Equipment Test

Both of these document titles have been clarified, following feed back from WDS.



## SMTH part 02 (extract)

NR/SIG/11231 Signal Maintenance Testing		
NR/SMTH/Part 02		
Introduction and Overview		
Issue No. 09	Issue Date: 03/03/18	Compliance Date: 31/05/18

### 9.4.3 Planning the Work

Pre-planned work involving SMTH if undertaken by Network Rail staff, shall be planned in accordance with the Infrastructure Maintenance Planning Handbook (NR/L3/MTC/PL0175). If the work is undertaken by contractors, the planning process used shall be comparable to that used by Network Rail.

The Maintenance Tester in overall charge of the work shall be identified at the planning stage.

In addition to the work planning process, technical information relating to the Maintenance Testing shall also be included as part of the overall work planning. This includes:

a) Wiring diagrams

b) Signalling plans

c) Where point systems are involved, an appropriate extract of the site plan (locking sketch) showing the normal lie of the points. Permutation charts shall be provided as part of the testing [NR/SMTH/Part 03/ Test B08](#).

Figure 16: Extract from Network Rail signal standards brief, March 2018, and the related change to section 9 of SMTH part 02 (images courtesy of Network Rail)



### Other individual factors

- 151 In March 2020, the maintenance tester needed to self-isolate as he had COVID-19 symptoms. The Inverness section manager was aware of this. The maintenance tester stated that he subsequently started to suffer from general tiredness, memory and concentration issues. He did not make the Inverness section manager aware of these issues because he felt they were not of sufficient concern and were not affecting his work. The maintenance tester believed that he was coping and that the sense of general tiredness was the result of other wellbeing concerns that his line managers already knew about. RAIB is unable to completely discount any problems that the maintenance tester started to have as a result of his COVID-19 symptoms as a factor in him not correctly reorientating to the original task of following the maintenance test plan.
- 152 RAIB found no evidence that the shift pattern worked by the maintenance tester would have resulted in unacceptable fatigue.

## Identification of underlying factors

### Independent verification

**153 Network Rail's signalling maintenance standards did not result in working arrangements that led to the maintenance tester carrying out checks and tests that were independent of those responsible for installing the point machine. This was a probable underlying factor.**

- 154 Whether signalling equipment replacement work is carried out in accordance with signal maintenance or signal works standards, Network Rail relies on the same principle of independent testing to ensure an adequate level of asset integrity before the modified signalling system is handed back into service. Independent testing is particularly important for minor signalling renewals undertaken by signalling maintenance teams when reconfiguration of the replacement item may be required.
- 155 For the principle of independence to be effective, two separate parties are required:
- the installation party responsible for ensuring the correct equipment is correctly installed and functions correctly
  - the testing party responsible for verifying the work carried out by the installation party.
- There needs to be clearly defined roles and responsibilities for each, together with prescribed arrangements for the handover between them.
- 156 For signalling works teams, definitions are included in SWTH and allied signalling works standards. However, the same level of definition is not provided in SMTH, or other standards that are relevant to signalling maintenance. RAIB found that the signalling maintenance standards did not clearly define:
- the roles and responsibilities of the installers
  - how the installers are to hand over the signalling system that they have modified to the maintenance tester

- practical rules and guidance on the degree to which an installer is allowed to assist a maintenance tester with their checks and tests.

It is probable that the lack of definition contributed to how the maintenance tester and the installers understood they should work together and the informal arrangements that resulted.

### *Roles and responsibilities of installers*

157 Where the installer is mentioned in SMTH it is almost solely with reference to ‘the person carrying out the work’. While SMTH has recently been updated<sup>27</sup> to include brief statements on task and competency, it does not define the roles and responsibilities of installers or the processes that they need to follow. Similarly, while it refers to a lead maintenance tester, it neither requires the appointment of a lead installer nor that members of the installation team are allocated to specific roles ahead of starting work.

158 Network Rail’s work instruction on signalling installation (NR/L3/SIG/11303) describes installation practice and guidance (although it too does not require the appointment of a lead installer). Installer A, who had informally assumed the role of lead installer, was unaware of this or any other process that he needed to follow. This may have been because there was no direct reference to SMTH in NR/L3/SIG/11303 (paragraph 64). Furthermore, although it includes a step-by-step process for point machine installation,<sup>28</sup> RAIB found no evidence that this was integrated with requirements of maintenance test plan PC51. Installer A generally relied on knowledge and experience when carrying out this type of work.

### *Handing over modified signalling systems for testing*

159 SMTH does not define any process or requirement for installers to formally hand over the signalling system when they have determined that it is ready to be tested. However, SWTH is quite specific for work carried out by signalling works teams, requiring a signed hand back certificate for points-related work. A similar or equivalent handover process would have helped define a boundary between the installers and the maintenance tester that could have reinforced an understanding and awareness of the independence that was required.

### *Installers’ assistance with independent testing*

160 Although SMTH refers to the principle of independent testing, RAIB found limited requirements or guidance concerning how installers and maintenance testers are expected to work together in practice. In particular, there is no definition of the circumstances under which an installer is allowed to help a maintenance tester, nor description of the controls that are needed to ensure that the maintenance tester’s independence is not compromised.

<sup>27</sup> SMTH part 02 issued on 5 December 2020, after the 13B point machine was replaced.

<sup>28</sup> Module 2S10 of NR/L3/SIG/11303.

161 SWTH is again specific, stating that, except in certain circumstances (which are listed), ‘staff who have participated by direct preparation, direct advice, or direct control of that particular design or installation, shall not assume testing responsibilities.’<sup>29</sup> SWTH includes other requirements designed to reinforce the separation of the installation and testing roles, and to manage matters such as conflicts of interest.

## Observations

### Competence management

**162 The Network Rail staff involved in the renewal work undertaken at 13 points did not hold all the competencies that Network Rail’s standards defined as relevant.**

163 Network Rail manages the risks associated with signal engineering staff competence via authority to work arrangements and requirements to hold IRSE licences (paragraph 65). RAIB examined the authority to work records of the maintenance tester and installer A. Both held module Sig 10,<sup>30</sup> ‘Undertake corrective and preventative maintenance of electro-mechanical point machines’, and module Sig 44 (referred to as module SMTH),<sup>31</sup> ‘Confirm that signalling systems have been tested to Signal Maintenance Testing Handbook requirements following maintenance/defect repair or renewal’ (paragraph 67).

164 However, installer A did not hold module Sig 31, ‘Install and adjust electromechanical point operating systems’. The competency standard for module Sig 31 states that it applies to ‘all circumstances where a person is required to install and adjust’ electromechanical point machines. The GRS 5E type of point machine fitted at 13B point end is listed. The competency standard includes performance and knowledge requirements associated with defect recognition, availability and interpretation of drawings and specifications, and the need for ‘pre-assembly checks’. While these are all potentially relevant to the identification of the wiring discrepancy involved, it is also likely that they were skills and abilities that had been acquired, practised, and assessed in relation to other modules.

165 While the requirements for modules Sig 31 and Sig 10 both cover detection and correspondence testing, neither cover the defined checks and tests for equipment type and wire counting. Network Rail explained that these would be included during the assessment of competency in signal maintenance testing (module SMTH).

166 NR/L2/SIG/10160 considers the installation of signalling equipment ‘as part of minor works’ as the type of work requiring IRSE licence 1.2.220 ‘Signalling installation technician’. Similarly, it considers that ‘SMTH testers’ require IRSE licence 1.4.160 ‘Signalling maintenance tester’.

<sup>29</sup> Module A110 of SWTH.

<sup>30</sup> They also held the endorsement for GRS 5E point machines.

<sup>31</sup> They also held the endorsement for point testing.

- 167 Installer A and the maintenance tester both held IRSE licence 1.4.230 'Signalling maintainer & fault finder' (paragraph 70). However, installer A did not hold IRSE licence 1.2.220, relating to installation, and the maintenance tester did not hold IRSE licence 1.4.160, relating to testing. Holding these licences would have meant that installer A and the maintenance tester had been independently assessed as being competent to carry out the work they were tasked with.
- 168 RAIB has concluded that NR/L2/SIG/10160 did not necessarily mandate the holding of these licences. Both installer A and the maintenance tester held the licence relevant to what would have been their main role (IRSE licence 1.4.230) and evidence suggests that it was considered that their competence to carry out their installation and testing work was demonstrated by them holding relevant modules of Network Rail's authority to work scheme (Sig 10 and module SMTH).
- 169 Although SMTH part 02 requires that maintenance testing and installation work is carried out by competent staff, it does not provide detail or guidance on the specific competency modules and IRSE licence categories that they need to hold. Similarly, RAIB found no detail or guidance in Network Rail's work instruction on signalling installation (NR/L3/SIG/11303).
- 170 While observing that some apparently relevant competencies were not held, RAIB has concluded, for the reasons described above, that it is highly unlikely that this prevented the wiring discrepancy in the 13B point machine from being identified.

### Previous occurrences of a similar character

- 171 The accident at Clapham Junction on 12 December 1988 resulted in the deaths of 35 people and injury to nearly 500 more. It occurred when a signal that should have been showing a danger (red) aspect, to protect a train ahead, erroneously showed a proceed aspect. The accident was investigated by Sir Anthony Hidden QC and the findings were published in a public report.<sup>32</sup>
- 172 The failure which caused the erroneous aspect arose from work carried out as part of a re-signalling scheme. A signalling relay was incorrectly energised when a wire, which had been disconnected, came back into contact with the relay. This caused a track circuit to show unoccupied, when in fact it was occupied by a train, thereby allowing the signal to show proceed. The failure would have been avoided if a wire count had been carried out. The report recommended that British Rail should urgently ensure that an independent wire count is carried out as a matter of course during signal testing.
- 173 The report also led to:
- the need to urgently develop national testing instructions and the introduction of the signal works testing and signal maintenance testing handbooks (SWTH and SMTH)
  - the separation of the signalling installation and testing roles
  - the need to improve training and certification of testers and the introduction of the IRSE licensing scheme.

<sup>32</sup> Investigation into the Clapham Junction Railway Accident, Anthony Hidden QC, ISBN 0 10 108202 9  
<https://www.railwaysarchive.co.uk/docsummary.php?docID=36>

174 RAIB has investigated several more recent occurrences involving wrong side failures of signalling equipment. Those with similar characteristics include:

- Greenhill Upper Junction, 22 March 2009 ([RAIB report 04/2010](#)). A passenger train ran through and damaged the mechanism of an incorrectly set point end which was part of a set of switch diamonds.<sup>33</sup> The train did not derail and continued normally on its journey. The incident followed work to renew the point machine at the other point end within the switch diamonds. The signaller had been able to set a route because incorrect additional wiring in the renewed point machine prevented the signalling system detecting that the switch rails were not in the correct position. The wiring discrepancy had remained undiscovered for over two months. Relevant RAIB recommendations resulting from this accident are discussed in paragraphs 181 to 185.
- Cardiff East Junction, 29 December 2016 ([RAIB report 15/2017](#)). A driver of a passenger train stopped three metres short of a set of points on noticing they were incorrectly set for its assigned route, thereby avoiding being diverted, undetected by the signalling system, onto a line that another train passed over about three minutes later. Extensive remodelling and re-signalling work was being carried out in the area. The points were redundant and should have been secured in readiness for complete removal. However, the points had been left in an unsafe condition because they had not been identified as requiring securing by the responsible team.
- London Waterloo, 15 August 2017 ([RAIB report 19/2018](#)). A passenger train collided with a stationary engineering train at 13 mph (21 km/h). There were no injuries but both trains were damaged and there was disruption to train services. The train was diverted from its assigned route by a set of points that were incorrectly set because of uncontrolled wiring. The wiring had been added to overcome a problem during the testing of signalling system modifications. In its report of this accident, RAIB stated its concern regarding the rail industry's fading collective memory of the lessons from the 1988 Clapham Junction accident. Relevant RAIB recommendations resulting from this accident are discussed in paragraphs 186 to 188.

---

<sup>33</sup> A crossing made up of two sets of points, which are arranged so their toes abut each other.

## Summary of conclusions

### Immediate cause

175 The signaller was able to clear DW3 signal, permitting train 5S85 to approach 13 points when they were in an unsafe condition (paragraph 74).

### Causal factors

176 The derailment occurred because the switch rails at 13 points were not in the correct position. The signalling system failed to detect this because an unwanted link and a strap were not removed from the internal wiring of one of the point machines when it was replaced on 28 June 2020.

177 The need to remove the link and strap was not identified as part of the work to install and test the reserviced point machine because of four causal factors:

- a. Renewal planning activity did not identify the need to alter the internal wiring in the reserviced point machine possibly because technical information that may have been relevant was either not reviewed or was not available (paragraph 86). This causal factor arose due to a combination of the following:
  - i. The section supervisor did not understand that he was supposed to consider listed technical information as part of the planning process. This is a possible factor (paragraph 90, **Recommendation 1**).
  - ii. No product information was made available to the Network Rail signalling engineering team that described how the internal wiring in the reserviced point machine was configured or that it was necessary to check if alteration was needed. This is a possible factor (paragraph 95, **Recommendation 2**).
- b. The pre-installation checks in the specified maintenance test plan did not identify the need to alter the internal wiring in the reserviced point machine (paragraph 104). This causal factor arose due to a combination of the following:
  - i. The pre-installation checks carried out by installer A did not identify the wiring discrepancy, possibly because of weaknesses in their definition and how they were executed (paragraph 110, **Recommendations 3 and 4**).
  - ii. The maintenance tester did not verify the checks carried out by installer A. This is a possible factor (paragraph 115, **Recommendation 4**).
- c. The post-installation wire count in the specified maintenance test plan did not identify the differences between the detection circuit wiring in the newly-installed point machine and the site wiring diagram (paragraph 119). This causal factor arose due to a combination of the following:
  - i. The wire count carried out by installer A did not cover the full scope of that required by the maintenance test plan (paragraph 124, **Recommendation 4**).

- ii. The maintenance tester incorrectly assumed that the work that installer A carried out meant that the full scope of the required wire count had been covered (paragraph 128, **Recommendation 5**).
- iii. The maintenance tester did not separately verify that the wire count had covered the full scope required by the maintenance test plan (paragraph 132, **Recommendation 4**).
- d. The maintenance tester did not complete the specified out-of-correspondence testing following installation of the reserviced point machine (paragraph 136, **Recommendation 5**).

178 Network Rail's signalling maintenance standards did not result in working arrangements that led to the maintenance tester carrying out checks and tests that were independent of those responsible for installing the point machine. This was a probable underlying factor (paragraph 153, **Recommendations 1 and 4**).

### Additional observation

179 Although not considered causal to the derailment on 10 April 2021, RAIB observes that the Network Rail staff involved in the renewal work undertaken at 13 points did not hold all the competencies that Network Rail's standards defined as relevant (paragraph 162, **Recommendation 1**).

## Previous RAIB recommendations relevant to this investigation

180 The following recommendations, which were made by RAIB as a result of its previous investigations, have relevance to this investigation.

[Incident at Greenhill Upper Junction, 22 March 2009, RAIB report 04/2010, Recommendations 2, 4 and 5](#)

181 These recommendations read as follows:

### Recommendation 2

*Network Rail should revise its procedures so that where planned project work is carried out under the SMTH, the arrangements for testing of the completed works (and any partially completed works) should be planned and documented in advance and briefed to those undertaking the work prior to the commencement of those works.*

### Recommendation 4

*Network Rail should consider the introduction of a process that is suitable for planned small-scale enhancement projects of the type originally conceived for the HW1000 point machine renewal project in Scotland. Consideration should be given to the inclusion of the following elements in any new process:*

- *a project specification;*
- *the issue of design drawings;*
- *a strategy for the testing, including the resources required;*
- *the appointment of the tester in advance;*
- *a written test plan; and*
- *a system that documents the completion of specific stages of the testing.*

### Recommendation 5

*Network Rail should review the adequacy of the system of written records arising from work carried out under the SMTH so that the completion of specific stages of work covered by the SMTH gives rise to specific records of what has been done.*

182 The Office of Rail and Road (ORR) updated RAIB on Network Rail's consideration of these recommendations on 19 July 2012. It concluded that Network Rail had taken action to implement all three.

183 In response to recommendation 2, ORR reported that Network Rail had issued a revision to the SMTH on 5 March 2011 requiring that, for 'all planned work', maintenance testing requirements needed to be documented and briefed in advance. RAIB has concluded that this was when Network Rail introduced the additional requirements for pre-planned work in section 9 of SMTH part 02 (paragraph 54).



- 184 In response to recommendation 4, ORR reported that Network Rail issued a new SWTH module (module G110) on 3 September 2011. ORR considered all six elements in the recommendation and concluded that, except for two, all were clearly covered. It provided reasoning for the two exceptions. From earlier correspondence, RAIB has concluded that Network Rail's objective was to define a signal testing regime 'half way' between SMTH and SWTH that could be used for small-scale renewal projects. Network Rail requires use of the flowchart in section 9 of SMTH part 02 to determine if module G110 is applicable (paragraph 54).
- 185 ORR reported that it had concluded that, by issuing module G110, Network Rail had also demonstrated that it had reviewed the adequacy of the system of written records arising from work covered by SMTH. This was required by recommendation 5.

[Collision at London Waterloo, 15 August 2017, RAIB report 19/2018, Recommendation 1](#)

- 186 This recommendation read as follows:

*Recommendation 1*

*Network Rail should take steps to reinforce the attitudes and depth of understanding needed for signal designers, installers and testers to safely apply their technical skills and knowledge. These steps should include:*

- *the education of existing staff and their managers, and future recruits, to promote a better understanding of industry processes, and an improved understanding of how the lessons learnt have shaped today's good practice;*
- *the enhancement of processes for the assessment, development and ongoing mentoring of the non-technical skills of signal designers, installers and testers; and*
- *measures to monitor and encourage compliance with process, and safe behaviours on projects.*

- 187 In March 2022, ORR reported that Network Rail had delivered a mixed programme of work to address the recommendation and provided a copy of Network Rail's closure statement explaining that this included:
- briefing signal engineering teams and their leaders on the accident and positive safety behaviours
  - developing and introducing competence modules for the non-technical skills required by signal engineering staff; these covered topics such as conscientiousness, communication and co-operation and working with others
  - reviewing the effectiveness of industry forums for sharing information relating to incidents and near misses, and the consequences of actions.
- 188 After reviewing the information Network Rail had provided, ORR reported it had concluded that Network Rail had taken action to implement the recommendation.

## Actions reported as already taken or in progress relevant to this report

- 189 In August 2019, Network Rail published its report of an investigation into problems faced during signal maintenance testing with the purpose of understanding if the SMTH testing process was ‘fit for purpose’ (‘Report into the robustness of the SMTH testing procedure’). The investigation followed a ‘perceived increase’ of ‘close calls’, incidents and wrong side signalling failures which had resulted from this type of signalling work. It considered the significance of a variety of factors.
- 190 Although finding that the SMTH testing process can provide effective controls, the report concluded that improvements could be made. The improvements primarily concerned competence management and process clarification and simplification. Recognising the reliance placed on the ‘attitude and aptitude’ of individuals involved, it also identified issues for escalation relating to resources and pressure. These issues included the need for senior signal maintenance team members to take on several roles (including COSS, maintenance tester, PIC, and team leader), section manager workload and pressures to hand back the railway. Report recommendations that were potentially relevant include:
- the introduction of practical-based assessment and re-certification of competence relating to SMTH-related activities
  - a ‘full review’ of the processes defined in SMTH part 02; matters highlighted include testing independence, work planning and management
  - a review of maintenance test plan content to identify changes so that testing independence is only mandated where necessary; Network Rail’s investigation team concluded there was a case for reducing the occasions when independence was required
  - issuing formal guidance on the accepted means of accessing SMTH information when staff are working on the track.
- 191 Network Rail issued a revision of SMTH (issue 16) on 4 September 2021 (compliance date 4 December 2021) following some major restructuring of the document (footnote 16). RAIB considers that a number of areas of learning identified in its investigation of this derailment are not addressed by the changes that were introduced.
- 192 In December 2020, Network Rail made changes mandating the use of wire count grid sheets (paragraph 131). In September 2021, it made changes clarifying the need to use permutation grid sheets (footnote 25).
- 193 Network Rail removed 13 points immediately after the derailment and installed plain line track on the up and down lines (paragraph 46). Network Rail has also started a project to remove all GRS 5E type point machines in the Scotland region. This is because of Unipart Rail’s decision to close its workshop in York (footnote 22). Network Rail’s plan is to replace the point machines with HW type equivalents.

- 194 On 14 April 2021, Network Rail issued a special inspection notice with the purpose of establishing if similar point machine configurations in the Scotland region were affected (ScoR/SIN/001). Forty-nine sites were identified where multi-ended points shared a common detection circuit. All had HW type point machines installed. No issues of concern were found at any of these locations and the inspection confirmed that 13 points at Dalwhinnie had been the only multi-ended points on the Scotland region where GRS 5E type point machines were installed.
- 195 Network Rail issued another special inspection notice on 19 April 2021 with the purpose of establishing if similar point machine configurations were affected on the wider network (NR/SIN/201). Inspection work identified internal detection wiring discrepancies at two locations; both involved HW type point machines:
- Orpington, on Network Rail's Kent route: the wiring was made correct to the wiring diagram.
  - Shildon, on Network Rail's North & East route: the points were clamped out of use with switch rails in the normal position.
- 196 Network Rail's own investigation of the derailment at Dalwhinnie has identified the need to further review SMTH process documents and to clarify that (unless the result of reactive fault-finding activity) all SMTH-related work should be planned in detail, and that all work elements need to be defined. Network Rail has reported that this review, and the preparation of any remits needed for changing standards, will be completed by December 2022.
- 197 Network Rail's investigation also identified the need for its technical head of signalling to define the additional test records (for instance, permutation charts and wire count grid sheets) that need to be provided together with the SMTH log sheet. Network Rail has reported that the recent changes to mandate the use of such records (paragraph 192) means that this is now addressed.
- 198 When making the recommendations in this report, RAIB has taken into account, as appropriate, the above recent changes that Network Rail has made to SMTH and the actions that it has reported it is undertaking as result of its own investigation into the derailment.

## Recommendations and learning points

### Recommendations

199 The following recommendations are made:<sup>34</sup>

- 1 *The intent of this recommendation is to ensure that signalling maintenance teams have a full and complete understanding of all the tasks required when carrying out pre-planned renewal work, and of each person's role and responsibility in undertaking such work. This recommendation should build on the findings of the review that Network Rail has scheduled as a result of its own investigation (paragraph 197).*

Network Rail should review and update its processes for signalling equipment installation and signal maintenance testing so that all work undertaken by signalling maintenance teams, that is not the result of reactive fault finding activity, is suitably planned and that sufficiently detailed instructions are made available.

This review should ensure that the resulting instructions include details of:

- the preliminary work required, such as establishing the relevant technical requirements and ensuring the suitability of the equipment to be installed
- designated roles for the work along with the respective tasks and responsibilities of each role
- the required competencies and licences required for each designated role
- the information each designated role needs to be provided with
- the process by which hand over between installation and testing and hand back between testing and railway operation will be arranged (paragraphs 177a.i, 178 and 179).

<sup>34</sup> Those identified in the recommendations have a general and ongoing obligation to comply with health and safety legislation, and need to take these recommendations into account in ensuring the safety of their employees and others.

Additionally, for the purposes of regulation 12(1) of the Railways (Accident Investigation and Reporting) Regulations 2005, these recommendations are addressed to the Office of Rail and Road to enable it to carry out its duties under regulation 12(2) to:

- (a) ensure that recommendations are duly considered and where appropriate acted upon; and
- (b) report back to RAIB details of any implementation measures, or the reasons why no implementation measures are being taken.

Copies of both the regulations and the accompanying guidance notes (paragraphs 200 to 203) can be found on RAIB's website [www.gov.uk/raib](http://www.gov.uk/raib).

- 2 *The intent of this recommendation is to ensure that, before replacing an item of signalling equipment with an item that is apparently similar, signalling engineering staff are able to detect if there is the possibility of the replacement item inadvertently affecting the safe operation of signalling infrastructure, and therefore that additional precautions and checks are required.*

Network Rail should review all replaceable items of signalling equipment that it has accepted on the basis of historical (grandfather) rights, which could affect the safe running of trains over switches and crossings. It should identify any items that may need to be modified, configured or adjusted before installation and ensure that information or warnings are provided to signalling engineering staff alerting them to this modification and the action that they need to take.

This recommendation may also be applicable to other types of signalling equipment that affect the safe running of trains (paragraph 177a.ii).

- 3 *The intent of this recommendation is to ensure that, when signalling maintenance teams replace signalling equipment, specified pre-installation checks are effective in confirming that the item being installed is operationally equivalent to the item being replaced.*

Network Rail should review its signal maintenance testing handbook and update the guidance for the defined check for correct equipment type to describe, in sufficient detail, the steps needed to determine like-for-like equipment equivalence. It should make enhancements so that the importance of following this guidance is clear to those installing and testing signalling equipment and, according to their appointed role, the work elements they are permitted to undertake.

This recommendation may be relevant to other defined checks that are described in Network Rail's signal maintenance test handbook (paragraph 177b.i)

- 4 *The intent of this recommendation is to ensure that, when signalling maintenance teams make engineering changes to the signalling infrastructure, the requirement for the maintenance tester to be independent of the installers is effective in assuring the integrity of the signalling system.*

Network Rail should review how it can best achieve the required level of independence between the installation and testing roles when pre-planned renewal work is carried out under the processes described in its signal maintenance testing handbook. This should take into account how people undertaking these roles work currently. It should make enhancements so that practical working arrangements are defined.

This recommendation may be relevant to other types of signalling work undertaken under arrangements described in Network Rail's signal maintenance test handbook (paragraphs 177b.i, 177b.ii, 177c.i, 177c.iii and 178).

- 5 *The intent of this recommendation is to reduce the likelihood of essential signal maintenance testing tasks being overlooked and not completed.*

Network Rail should review its arrangements for recording progress when carrying out testing defined in its signal maintenance testing handbook. This should take into account environmental and other challenges relevant to the workplace and make enhancements that ensure practical contemporaneous recording of:

- the completion of each test step
- relevant test results, measurements, and findings (paragraph 177c.ii and 177d).

## Learning points

200 RAIB has identified the following important learning points:<sup>35</sup>

- 1 Installers and testers should follow processes that are designed to assure the integrity of signalling systems before handing them back into service after engineering work that has the potential to alter their condition or configuration.
- 2 Employers should ensure as far as possible that they are aware of medical, health and personal issues relevant to members of staff that carry out safety-critical work.

---

<sup>35</sup> 'Learning points' are intended to disseminate safety learning that is not covered by a recommendation. They are included in a report when RAIB wishes to reinforce the importance of compliance with existing safety arrangements (where RAIB has not identified management issues that justify a recommendation) and the consequences of failing to do so. They also record good practice and actions already taken by industry bodies that may have a wider application.

## Appendices

### Appendix A - Glossary of abbreviations and acronyms

CapEx	Capital expenditure
COSS	Controller of site safety
IRSE	Institution of Railway Signal Engineers
ORR	Office of Rail and Road
OTDR	On-train data recorder
PIC	Person in charge
RAM(S)	Regional asset manager for signalling
S&TME	Signalling and telecoms maintenance engineer
SIH	Signalling installation handbook
SMS	Signal maintenance specifications
SMTH	Signal maintenance testing handbook
SWTH	Signal works testing handbook

## Appendix B - The circuitry associated with 13 points

- B1 A signaller sets a route over 13 points by operating levers in Dalwhinnie signal box. The required position of the points is determined by the signaller moving a lever for 13 points to either its normal or reverse position. The position of the lever is electrically detected by the interlocking in the Dalwhinnie relay room to determine which position the points should be commanded to be in. This information is then passed via cables to equipment in location case 58/2B near to the point machines (figure 2). This command is known as points calling.
- B2 The relays in the location case that provide the local commands to 13 points, and detect the position of the switch rails, are listed in table B1.

Relay name	Function
13ANWR	Local command to call 13A point end to normal position
13ARWR	Local command to call 13A point end to reverse position
13BNWR	Local command to call 13B point end to normal position
13BRWR	Local command to call 13B point end to reverse position
13NWKR	Local detection relay – energised when all switch rails at 13 points are in normal position
13RWKR	Local detection relay – energised when all switch rails at 13 points are in reverse position

*Table B1: Relays associated with the control of 13 points*

- B3 Each relay consists of a coil, an armature and a set of contacts. When a voltage is applied to the coil, an electromagnetic field is set up which attracts the armature causing it to move. This action operates the set of contacts which are referred to as either front or back contacts. Back contacts are closed when the relay is de-energised and open when energised; front contacts are closed when the relay is energised and open when de-energised. The relays operate at a nominal 50 volts DC.
- B4 The two detection relays, 13NWKR and 13RWKR, are co-located in a single plug-in relay housing (commonly known as a BR930 Q style relay) and each has six front and two back contacts. They are biased relays, which only energise when current is flowing in one direction through their coil.
- B5 Figure B1 shows a simplified diagram of the detection circuit associated with 13 points. The detection contacts are contained inside the point machines and are wired in series between each point end. The detection contacts need to be made, in either the normal or reverse position, in both point machines for the appropriate detection relay (13NWKR or 13RWKR) to energise. This should only occur when the associated switch rails are in the correct position.



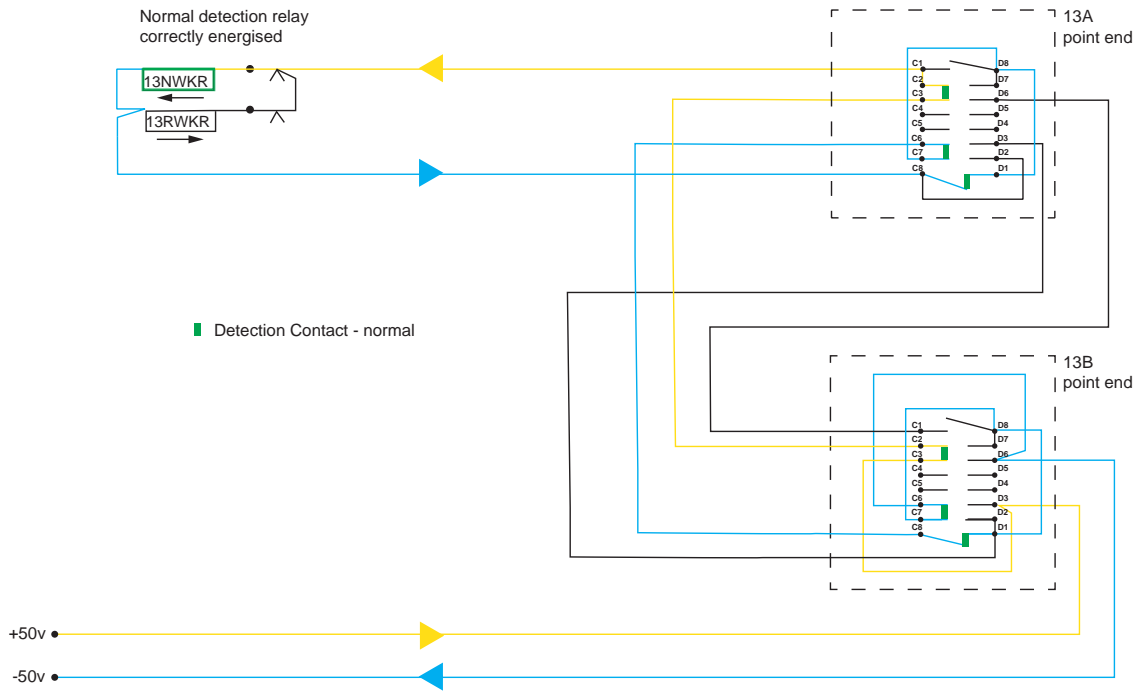

Figure B1: Simplified diagram of the detection circuit associated with 13 points as designed (showing switch rails detected in normal position at both point ends)

B6 On a GRS 5E type point machine, detection contacts comprise two metal H-shaped pieces which are attached to a rocker. The rocker moves from one side to the other side depending on the position of the switch rails. For 13 points, when detection is obtained in the normal position, the H-shaped pieces are in contact with fixed springs connected to the terminals designated by prefix ‘C’; for detection in the reverse position, they are in contact with springs connected to terminals designated by prefix ‘D’ (figure B2). If detection is lost, a back contact of the appropriate detection relay energises the respective points calling relays (13ANWR and 13BNWR, or 13ARWR and 13BRWR) to command the points to move back to the required position, in an attempt to regain detection.

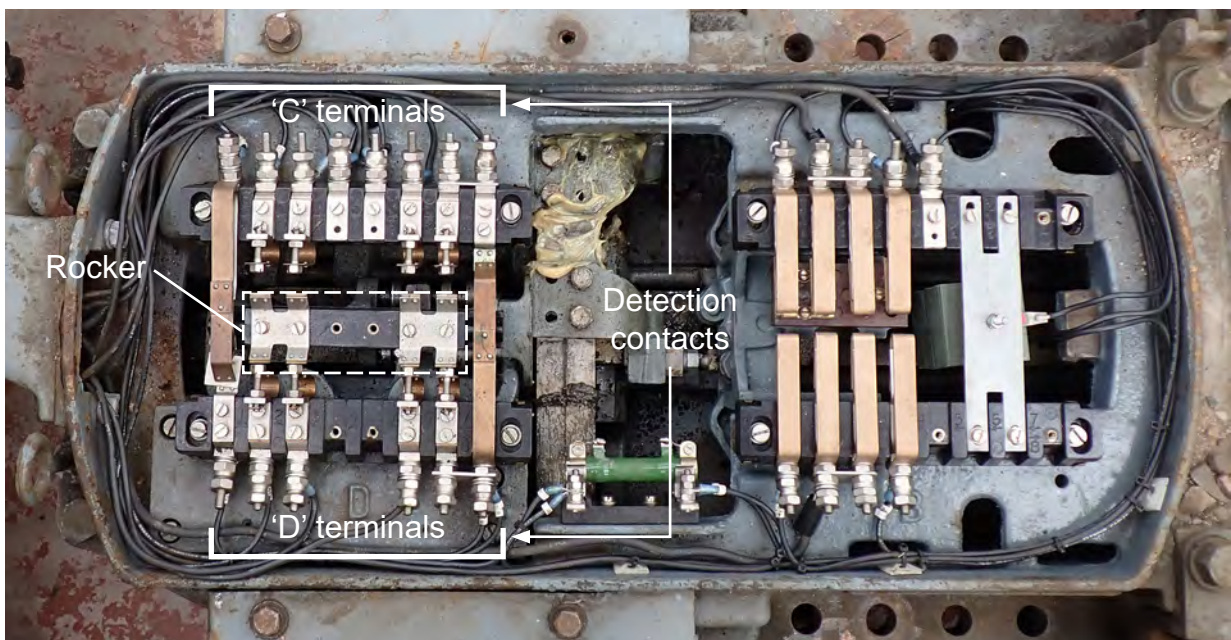

Figure B2: GRS 5E type point machine detection contacts

- B7 The circuit containing the detection relays, 13NWKR and 13RWKR, uses two wires to connect them to the detection contacts in the point machines. Such a circuit is known as a pole changing circuit as the polarity (the direction of the electric current) is changed depending on which set of detection contacts are made. The detection contacts in each point machines are also connected in series, so the detection in the 13A point machine and the 13B point machine is combined into one overall detection status for 13 points.
- B8 Contacts on the 13NWKR and 13RWKR relays are used to provide information about the position of 13 points back to the interlocking in the Dalwhinnie relay room. This information is used by the interlocking when determining if a signal for a route over 13 points can be cleared. The information is also used to provide an indication in the signal box, so the signaller can see if 13 points are detected in either their normal or reverse position or are in an undetected position.
- B9 With the switch rails at 13A point end in the reverse position, and those at the 13B point end in the normal position (paragraph 81), 13 points were out-of-correspondence. For this condition, analysis of the as-designed circuit shows that neither of the detection relays should have energised (figure B3). However, with the two additional conductors in the point machine at 13B point end (between terminals C1 and C2; and C8 and D2) detection relay 13NWKR is incorrectly energised (figure B4).

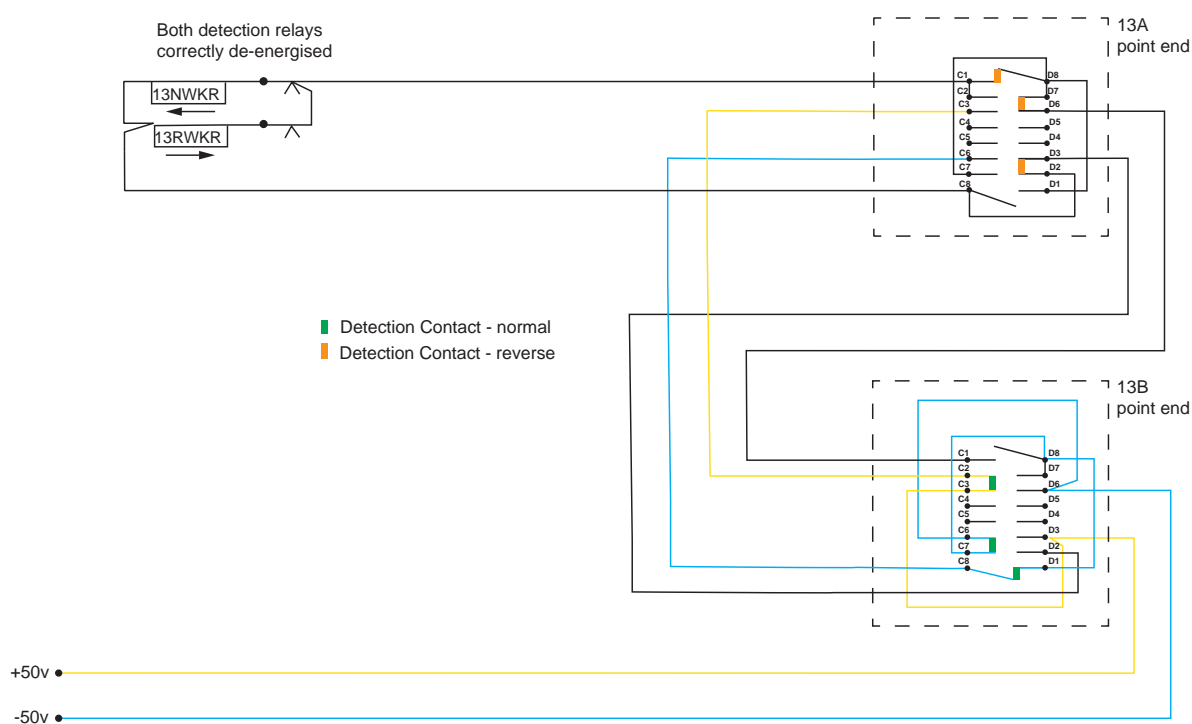

Figure B3: As-designed detection circuit for 13 points showing 13A point end reverse and 13B point end normal – neither detection relays energise

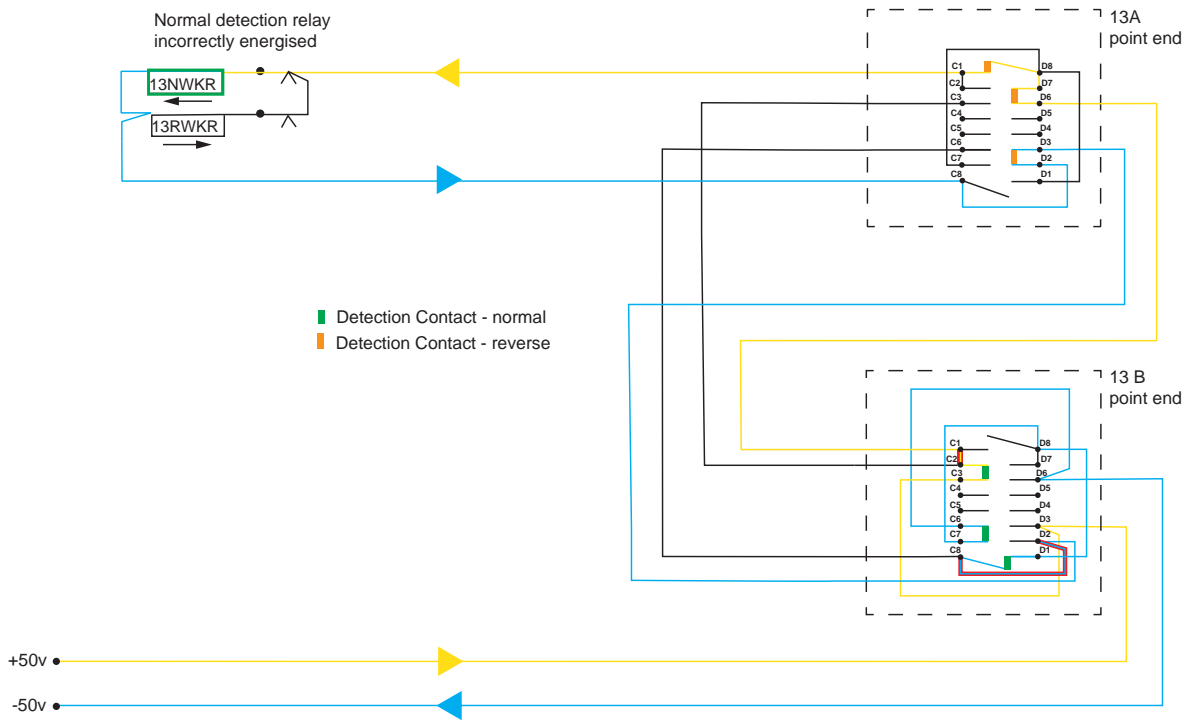

Figure B4: Detection circuit for 13 points with additional conductors (red) showing 13A point end reverse and 13B point end normal – detection relay 13NWKR is incorrectly energised

This page is intentionally left blank

---

This report is published by the Rail Accident Investigation Branch,  
Department for Transport.

© Crown copyright 2022

Any enquiries about this publication should be sent to:

RAIB	Email: <a href="mailto:enquiries@raib.gov.uk">enquiries@raib.gov.uk</a>
The Wharf	Telephone: 01332 253300
Stores Road	Website: <a href="http://www.gov.uk/raib">www.gov.uk/raib</a>
Derby UK	
DE21 4BA	