



Rail Accident Investigation Branch

Rail Accident Report



Collision at London Waterloo 15 August 2017

Report 19/2018
November 2018

This investigation was carried out in accordance with:

- the Railway Safety Directive 2004/49/EC;
- the Railways and Transport Safety Act 2003; and
- the Railways (Accident Investigation and Reporting) Regulations 2005.

© Crown copyright 2018

You may reuse this document/publication (not including departmental or agency logos) free of charge in any format or medium. You must reuse it accurately and not in a misleading context. The material must be acknowledged as Crown copyright and you must give the title of the source publication. Where we have identified any third party copyright material you will need to obtain permission from the copyright holders concerned. This document/publication is also available at www.gov.uk/raib.

Any enquiries about this publication should be sent to:

RAIB	Email: enquiries@raib.gov.uk
The Wharf	Telephone: 01332 253300
Stores Road	Website: www.gov.uk/raib
Derby UK	
DE21 4BA	

This report is published by the Rail Accident Investigation Branch, Department for Transport.

Cover photograph courtesy of Jamie Squibbs

Preface

The purpose of a Rail Accident Investigation Branch (RAIB) investigation is to improve railway safety by preventing future railway accidents or by mitigating their consequences. It is not the purpose of such an investigation to establish blame or liability. Accordingly, it is inappropriate that RAIB reports should be used to assign fault or blame, or determine liability, since neither the investigation nor the reporting process has been undertaken for that purpose.

The RAIB's findings are based on its own evaluation of the evidence that was available at the time of the investigation and are intended to explain what happened, and why, in a fair and unbiased manner.

Where the RAIB has described a factor as being linked to cause and the term is unqualified, this means that the RAIB has satisfied itself that the evidence supports both the presence of the factor and its direct relevance to the causation of the accident. However, where the RAIB is less confident about the existence of a factor, or its role in the causation of the accident, the RAIB will qualify its findings by use of the words 'probable' or 'possible', as appropriate. Where there is more than one potential explanation the RAIB may describe one factor as being 'more' or 'less' likely than the other.

In some cases factors are described as 'underlying'. Such factors are also relevant to the causation of the accident but are associated with the underlying management arrangements or organisational issues (such as working culture). Where necessary, the words 'probable' or 'possible' can also be used to qualify 'underlying factor'.

Use of the word 'probable' means that, although it is considered highly likely that the factor applied, some small element of uncertainty remains. Use of the word 'possible' means that, although there is some evidence that supports this factor, there remains a more significant degree of uncertainty.

An 'observation' is a safety issue discovered as part of the investigation that is not considered to be causal or underlying to the event being investigated, but does deserve scrutiny because of a perceived potential for safety learning.

The above terms are intended to assist readers' interpretation of the report, and to provide suitable explanations where uncertainty remains. The report should therefore be interpreted as the view of the RAIB, expressed with the sole purpose of improving railway safety.

The RAIB's investigation (including its scope, methods, conclusions and recommendations) is independent of any inquest or fatal accident inquiry, and all other investigations, including those carried out by the safety authority, police or railway industry.

This page is intentionally left blank

Collision at London Waterloo, 15 August 2017

Contents

Preface	3
Summary	7
Introduction	8
Key definitions	8
The accident	9
Summary of the accident	9
Context	11
The sequence of events	15
Key facts and analysis	19
Background information	19
Identification of the immediate cause	28
Identification of causal factors	29
Identification of underlying factors	43
Observations	45
Parallels with the Clapham Junction accident	46
Summary of conclusions	51
Immediate cause	51
Causal factors	51
Underlying factor	51
Observations	52
Parallels with the Clapham Junction accident	52
Actions reported as already taken	53
Recommendations and learning points	54
Recommendations	54
Learning points	56
Appendices	57
Appendix A - Glossary of abbreviations and acronyms	57
Appendix B - Investigation details	58
Appendix C - 1524 points wiring at the time of derailment	59

This page is intentionally left blank

Summary

At around 05:42 hrs on Tuesday 15 August 2017, a passenger train was leaving London Waterloo station when it collided with a stationary engineering train at a speed of 13 mph (21 km/h). No injuries were reported but both trains were damaged and there was serious disruption to train services until the middle of the following day.

The passenger train was diverted away from its intended route by a set of points which were positioned incorrectly as a result of uncontrolled wiring added to the signalling system. This wiring was added to overcome a problem that was encountered while testing signalling system modifications which were being made as part of a project to increase station capacity. The problem arose because the test equipment design process had not allowed for alterations being made to the signalling system after the test equipment was designed.

The actions of a functional tester were inconsistent with the competence expected of testers. As a consequence, the uncontrolled wiring was added without the safeguards required by Network Rail signalling works testing standards, and remained in place when the line was returned to service.

A project decision to secure the points in the correct position had not been implemented.

An underlying factor was that competence management processes operated by Network Rail and some of its contractors had not addressed the full requirements of the roles undertaken by the staff responsible for the design, testing and commissioning of the signalling works.

The RAIB has observed that there are certain similarities between the factors that caused the Waterloo accident and those which led to the serious accident at Clapham Junction in 1988. The RAIB has therefore expressed the concern that some of the lessons identified by the public inquiry, chaired by Anthony Hidden QC following Clapham, may be fading from the railway industry's collective memory.

As a result of the investigation, the RAIB has made three recommendations. The first, addressed to Network Rail, seeks improvements in the depth of knowledge and the attitudes needed for signal designers, installers and testers to deliver work safely. Recommendations addressed to OSL Rail Ltd and Mott MacDonald Ltd seek development and monitoring of non-technical skills among the staff working for them.

The RAIB has also identified four learning points. One highlights the positive aspects of a plan intended to mitigate an unusually high risk of points being moved unintentionally. The others reinforce the need to follow established procedures, prompt staff to clearly allocate duties associated with unusual activities and remind staff that up-to-date signalling documentation must be available and easily identified in relay rooms and similar locations.

Introduction

Key definitions

- 1 Metric units are used in this report, except when it is normal railway practice to give speeds and locations in imperial units. Where appropriate the equivalent metric value is also given.
- 2 The report contains abbreviations explained in appendix A. Sources of evidence used in the investigation are listed in appendix B.

The accident

Summary of the accident

- 3 At around 05:42 hrs on Tuesday 15 August 2017, a passenger train leaving platform 11 at London Waterloo station collided with a stationary engineering train (figures 1 and 2) while travelling at about 13 mph (21 km/h). There were no injuries, but both trains were damaged and there was serious disruption to train services.
- 4 The passenger train was the 05:40 hrs South West Trains service from Waterloo to Guildford and comprised 10 coaches. The engineering train was standing on a line adjacent to the intended route of the passenger train.

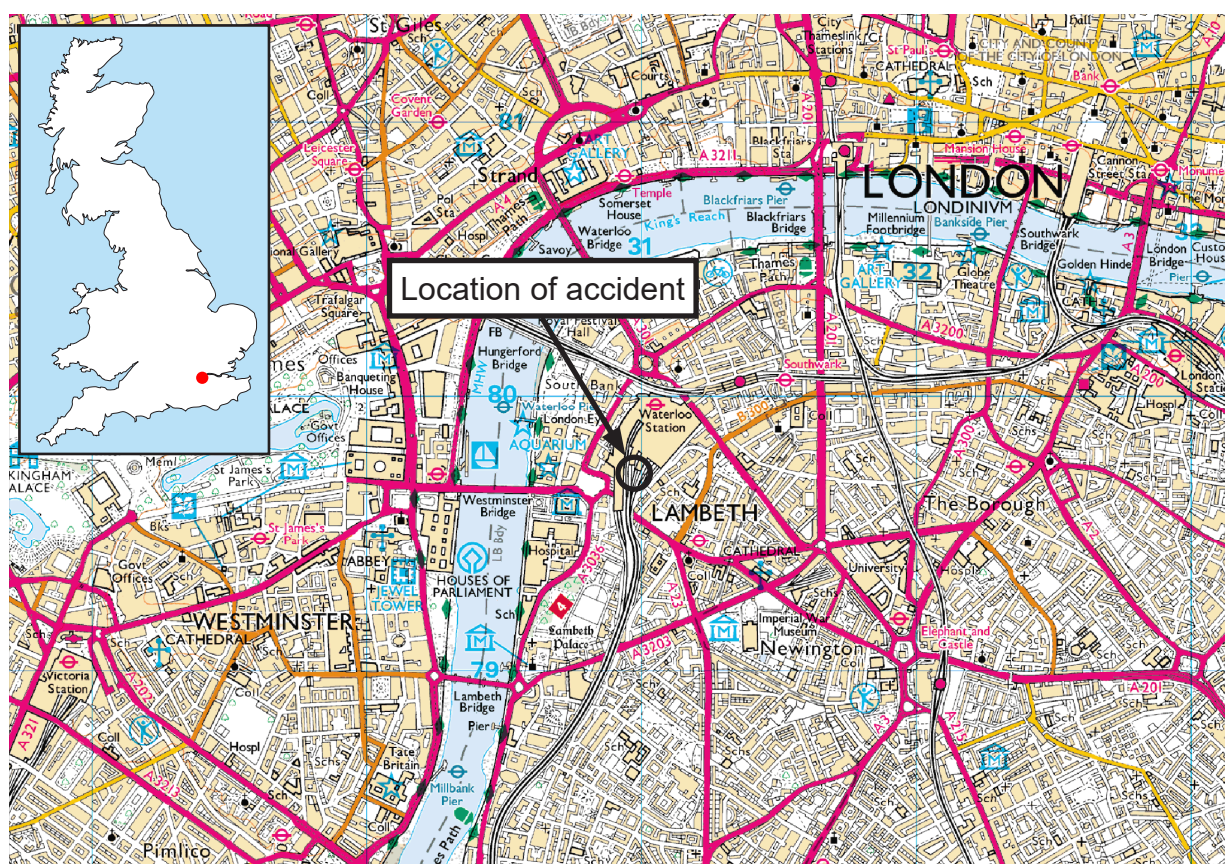

Figure 1: Extract from Ordnance Survey map showing location of accident

- 5 The collision occurred because a set of points was not in the correct position and directed the passenger train away from its intended route. The points were in this position because of an uncontrolled modification to the points control system, which also caused the train driver and signaller to receive indications that the points were correctly set.
- 6 The Wessex capacity improvement project was ongoing at London Waterloo station at the time of the accident (figure 3). Design of these works commenced in mid-2015 and construction was undertaken in a series of stages, with work on site beginning in November 2015.



Figure 2: Passenger and engineering train after the collision

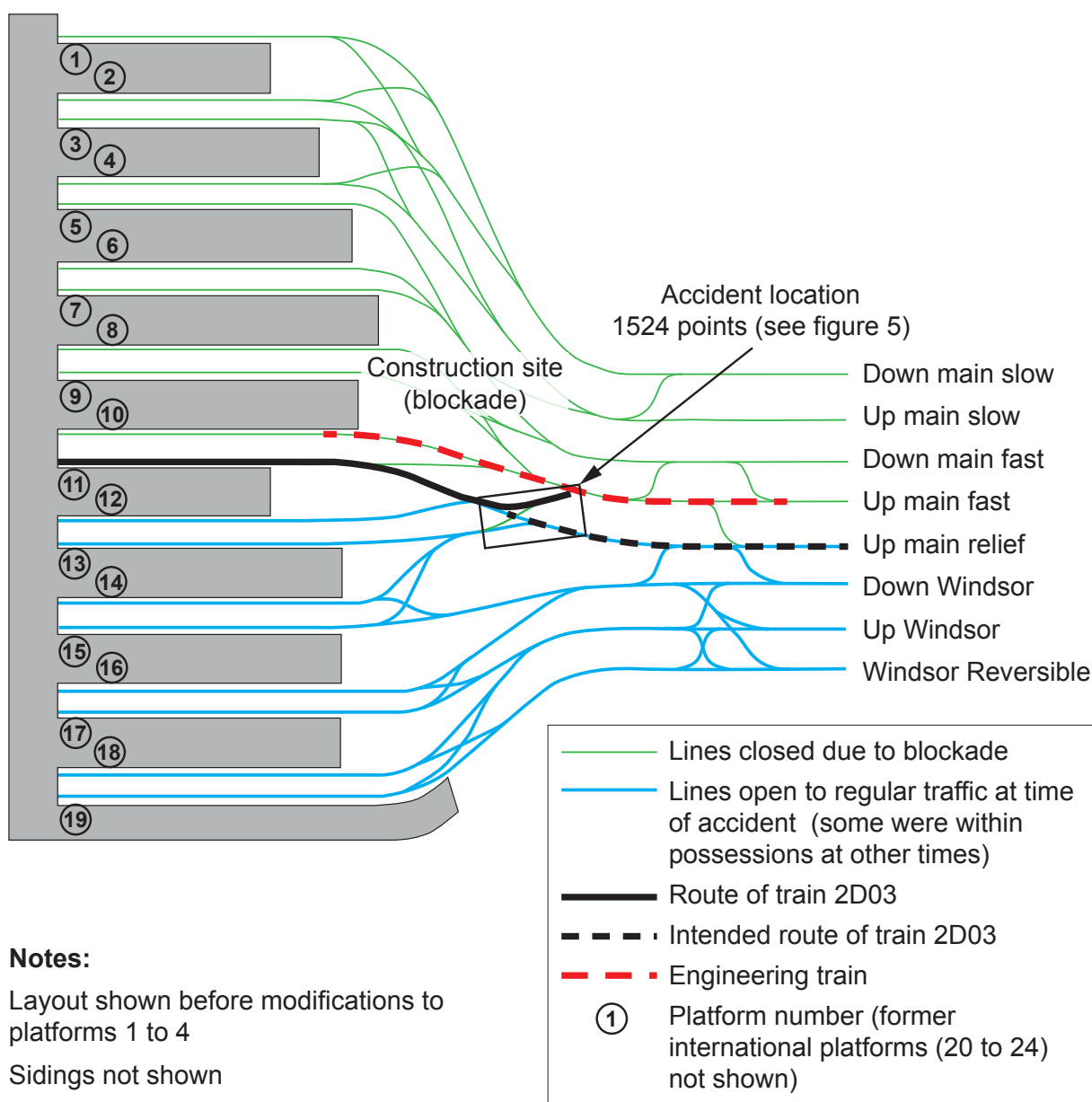

Figure 3: Overview of station and accident (photograph courtesy of Jamie Squibbs)

Context

Location

7 Waterloo station comprises 24 terminal platforms, numbered 1 to 24 from east to west, including platforms 20 to 24 in the former international station. Platforms 1 to 19 are connected to eight running lines designated, from east to west, down and up main slow, down and up main fast, up main relief, down and up Windsor and Windsor reversible (figure 4).



Notes:

Layout shown before modifications to platforms 1 to 4

Sidings not shown

Figure 4: Schematic layout of tracks (platforms 1 to 19) at London Waterloo station

8 At the time of the accident, platforms 1 to 10 were closed to allow construction of capacity improvement works (figure 3). These included extensions to platforms 1 to 4 and associated changes to trackwork and signalling. Construction work was being undertaken in stages and required testing of signalling and points in the area of the accident near the end of platform 11.

Organisations involved

- 9 Network Rail is the owner and maintainer of the infrastructure.
- 10 South West Trains (the trading name of Stagecoach South Western Trains Limited) was the operator of the train and employer of the driver. The franchise for passenger train operations in this area passed to South Western Railway, the trading name of First MTR South Western Trains Limited, on 20 August 2017.
- 11 The Wessex Capacity Alliance (WCA) comprised several organisations including Network Rail, Colas Rail and Mott MacDonald. The WCA was undertaking improvement works at Waterloo and its approaches.
- 12 Colas Rail's roles in the WCA included managing the design, testing and installation of signalling systems. It was also responsible for the installation of new signalling equipment and the modification of existing signalling equipment.
- 13 Mott MacDonald Ltd's (MML) roles in the WCA included design and checking of the signalling arrangements for each of the stages of the upgrading works.
- 14 OSL Rail Ltd (OSL) was contracted to Colas Rail to undertake testing of signalling equipment. OSL's roles included the design and checking of a test desk, part of the equipment required for testing of the new and modified signalling arrangements.
- 15 Each of these organisations freely co-operated with the investigation.

Staff involved

- 16 A functional tester was involved with installation of uncontrolled wiring relevant to the accident. He had worked on the railway since 2002 and had been employed by OSL since February 2013. He had undertaken various signalling testing roles at Waterloo since 2015. He first obtained the Institution of Railway Signal Engineers (IRSE) licences and certificate of competency¹ needed to be a verification tester and functional tester in November 2003 and October 2004 respectively. His certificate of competency to act as a functional and verification tester had been revoked on 7 March 2012 and reinstated on 14 April 2014 after mentoring (paragraph 164).
- 17 The tester in charge (TIC) had overall responsibility for testing the various stages of signalling modifications made during the capacity improvement works at Waterloo. He had been employed by OSL since 2010 and working on the project since 2015. He had been a signalling works tester in charge since 1993. At the time of the accident, his licence to undertake this role had expired but, as permitted by Network Rail procedures, he was continuing to undertake tester in charge duties while working towards its renewal.
- 18 The contractor's responsible engineer (CRE) for signalling design approved the drawings and other documents relating to both the various stages of signalling modifications, designed by MML, and to the test desk, designed by OSL. He was employed by MML as a contractor and had worked in various roles in railway signalling since 1993. He had held several roles in signalling design management and had been the contractor's responsible engineer for signalling elements of projects at Bletchley, Nottingham and Southampton.

¹ The testing roles, licensing system and associated competence certification are described in paragraphs 43 to 52.

- 19 The project engineer (signalling) was responsible, on behalf of Network Rail, for accepting the drawings and other documents relating to both the various stages of signalling modifications and to the test desk. He had been a contractor to Network Rail since October 2013, and had been employed in various railway signalling roles since 1989. He had carried out the role of project engineer on previous projects. None of these had both the size and the complexity of the capacity enhancement project at Waterloo.

Rail equipment involved

- 20 The area was signalled using a route relay interlocking² (paragraphs 54 and 55) commissioned in 1990, and controlled from Wimbledon area signalling centre. The interlocking controlling the signalling and points for the area of the accident was in Waterloo relay room, adjacent to the down main slow line near platform 1.
- 21 The collision occurred at 1524 points. This incorporated three pairs of point ends (denoted A, B and C) which connect platforms 11, 12, 13 and 14 to the up main fast and up main relief lines (figure 5). The route taken depended on whether the points were set to the normal or reverse position.

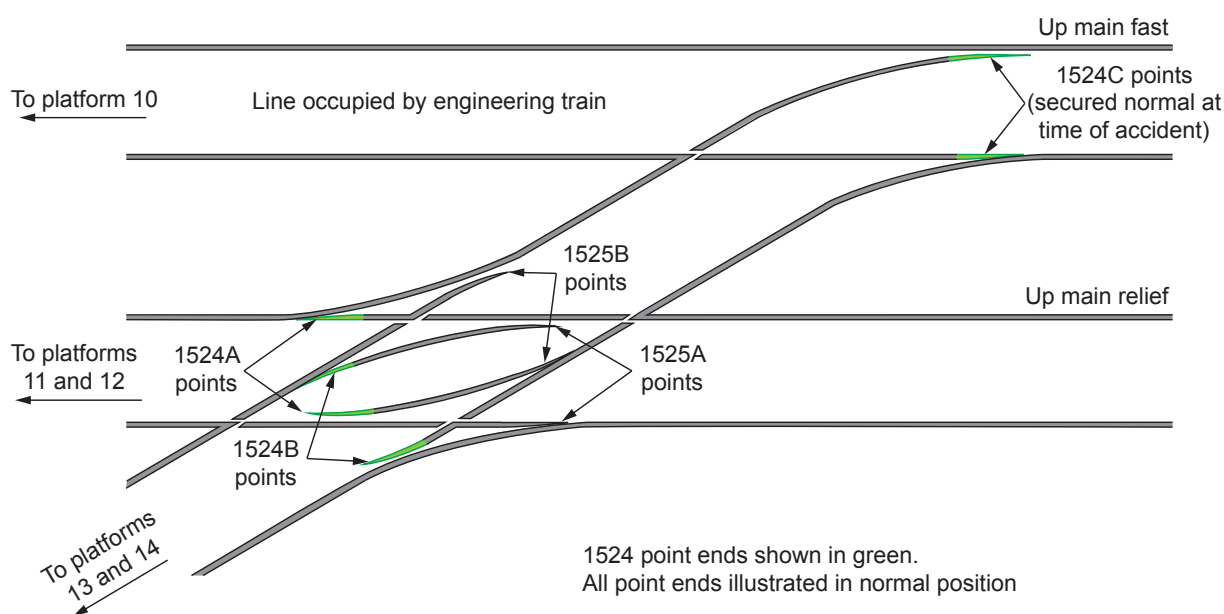

Figure 5: Schematic layout of 1524 points, the accident location

- 22 The three pairs of ends of 1524 points were intended to swing together so that all were in the normal position, or all were in the reverse position. When correctly in the normal or reverse position, the point ends should have been mechanically locked and confirmed to be (ie detected) in this position before a train was permitted to pass over them.

² A signalling interlocking is a system of controls fitted to railway signalling equipment which prevents conflicting or unsafe routes from being set.

- 23 A test desk was installed in Waterloo relay room in August 2016. This comprised electrical equipment which provided the interlocking with the simulated inputs, representing operation of trackside equipment, needed to test the interlocking during possessions³. The test desk's functionality included simulating the operation of 1524 points (paragraph 64).

Trains involved

- 24 The passenger train, reporting number 2D03⁴, was the 05:40 hrs South West Trains service from Waterloo to Guildford. It was formed of a class 456 and two class 455 electric multiple units, a total of 10 coaches.
- 25 The engineering train was positioned on the up main fast line and alongside part of platform 10. It was formed of ten empty side tipping wagons and five empty open wagons with a class 66 locomotive at the end closest to the buffers of platform 10. The train provided a physical barrier between the operational railway and the construction site⁵. South West Trains stated that it also provided a visual barrier to minimise distraction for train drivers operating in the open part of London Waterloo.

External circumstances

- 26 At the time of the accident it was getting light (sunrise was at 05:46 hrs) and the weather was clear and dry. There is no evidence that these external circumstances affected the accident.

³ A possession is a period when line(s) are closed to regular trains and maintenance or construction work is able to be undertaken.

⁴ An alphanumeric code, known as the 'train reporting number', is allocated to every train operating on Network Rail's infrastructure.

⁵ As required by Network Rail publication COP0032, 'Any Line Open (ALO) Working'.

The sequence of events

Events preceding the accident

- 27 Construction of the capacity improvement works required a blockade, closing platforms 1 to 10 and four main lines on the approaches to Waterloo station. The blockade started on 5 August. During the blockade, several possessions were required covering other parts of the station to allow testing which could not be carried out while regular train services were operating. The last of these possessions before the accident included all of Waterloo station and its approaches. The area of this possession was returned to operational use at 04:42 hrs on 15 August, an hour before the accident.
- 28 At 05:16 hrs a signaller at Wimbledon set a route into Waterloo station for a train which passed over 1524A points at 05:17 hrs. This train was routed into platform 11 where it later formed the passenger train involved in the accident. A second train passed over 1524A points at 05:35 hrs as it proceeded to platform 12. Both these inbound trains passed over 1524A points in the trailing⁶ direction and did not cause any adverse indications to the signaller or train drivers.

Events during the accident

- 29 At 05:40 hrs the signaller set a route for train 2D03 to leave platform 11. The panel display at Wimbledon indicated that it was safe for the train to do this (figure 6). The train driver received a green signal with 'UR' displayed on the adjacent theatre indicator (figure 7). This indicated that it was safe for his train to leave the platform and proceed along the up main relief line. The train departed at 05:41 hrs.

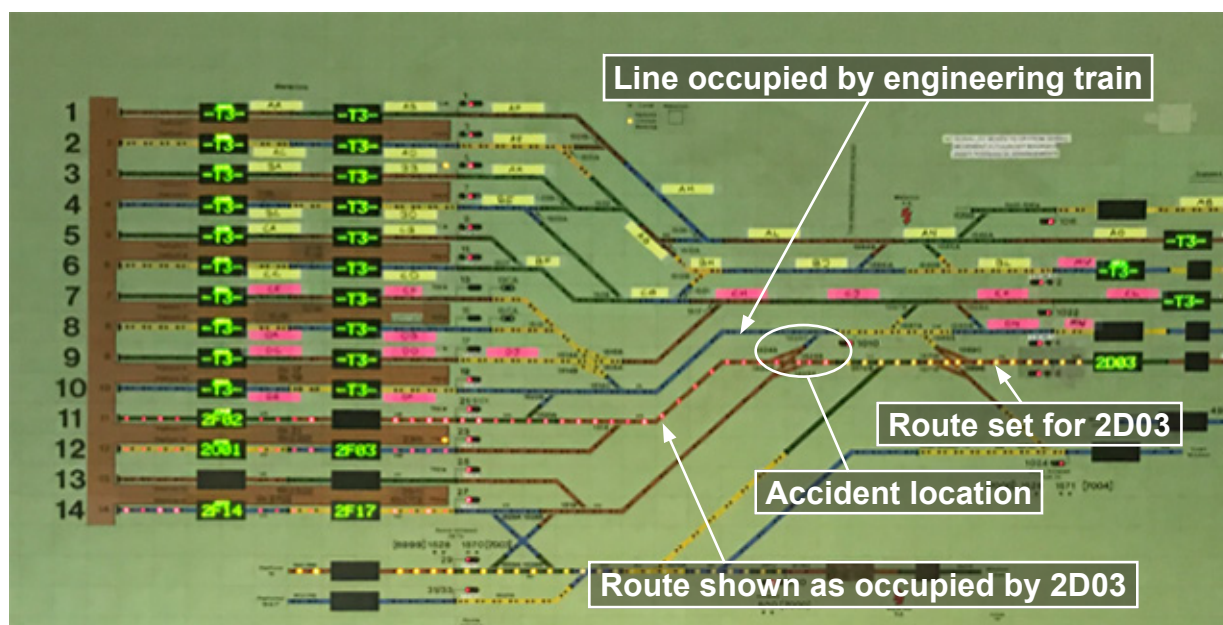

Figure 6: Signaller's panel at Wimbledon showing the route out of platform 11 set for and occupied by train 2D03. (Indicators are not illuminated for the engineering train as inputs were not provided to these indicators during parts of the construction work.)

⁶ Although the design of 1524 points required them to be set in the correct position (normal or reverse), movements in the trailing direction would result in trains pushing any incorrectly positioned point ends towards the required position. In this instance point ends were pushed towards the normal position shown on figure 5.



Figure 7: Forward facing CCTV from train 2D03 showing the green signal and 'UR' (up main relief) route indication displayed at high and low levels as it departed from platform 11 (courtesy South Western Railway)

- 30 Soon after moving away from the platform, the train was travelling at about 15 mph (24 km/h) when the driver noticed that 1524 points were not correctly set and applied the train's brakes (figure 8). The points should have been set to direct the train straight on, but were incorrectly lying in an intermediate state and directed the train to the left and into the side of the engineering train. The collision occurred about three seconds after the brake application which had reduced the train's speed to 13 mph (21 km/h). Drivers are not required, and not expected, to check point positions in these circumstances. The driver of train 2D03 is to be commended for noticing that they were lying incorrectly and for his prompt brake application.
- 31 After the collision, the passenger train slid along the side of the engineering train for around four seconds before coming to a stop with the left-hand wheels of the leading coach above the rail and the right-hand side wheels remaining on the rail (figure 9).



Figure 8: View from the train's forward facing CCTV showing 1524A points lying approximately midway between normal (wide gap at right-hand point end, no gap at left-hand point end) and reverse (gap only at left-hand point end)



Figure 9: Train 2D03 with left (in direction of travel) wheels of the leading bogie above the rail

Events following the accident

- 32 Immediately after the accident, the train driver made a GSM-R⁷ railway emergency call which caused an emergency stop message to be broadcast to all trains in the Waterloo area.
- 33 All but two passengers on train 2D03 were in the rear eight coaches (formed by the two class 455 units) and left the train after the guard opened doors alongside platform 11. The remaining two passengers were in the class 456 unit at the front of the train. This unit was beyond the end of the platform and there was no corridor connection between the units. These passengers returned to the station along the track, escorted by railway staff.
- 34 Network Rail and South Western Railway have stated that they have no record of any passengers or staff requiring medical treatment for physical injuries. Some people involved suffered from emotional shock after the accident.
- 35 The accident caused severe disruption to train services in and out of London Waterloo, while the train was recovered and the points repaired. Platforms 11 and 12 were closed until 12:30 hrs on 16 August.

⁷ Global System for Mobile communications – Railways is a national radio system which provides secure voice and data mobile communications between trains and signallers.

Key facts and analysis

Background information

Signalling design, installation and testing processes

- 36 Railway safety is dependent on ensuring signalling systems are fully effective during routine train operations and not adversely affected when modifications are in progress. Network Rail's standard processes for the design and installation of such equipment are summarised below in simplified form. It should be noted that these processes require all work to be checked and require testing to be carried out by people who were not involved in the design.
- 37 The first part of the design process defines the new track layout required and the conditions which must be met before an action can be implemented, for example, the position of points (normal or reverse) required before signals permit a train to enter a section of track. This information is set out in the scheme plan⁸ and control tables⁹. These are prepared by a signalling designer (or signalling design team) and checked by a different signalling designer (or team).
- 38 Detailed design of the signalling system, including the arrangement of wires and relays (electrically operated switches) in the interlocking, is carried out by a signalling designer and checked by a different signalling designer. Again, these can be teams rather than individuals. The detailed design documents for the capacity improvement works at Waterloo included:
- wiring diagrams;
 - analysis sheets, which detailed the number of wires connected to each terminal; and
 - for the test desk only:
 - an operation schedule which detailed which fuses and isolation links needed to be added or removed to use each test desk function; and
 - a test desk methodology document detailing the method of connecting and disconnecting the test desk.
- 39 Control tables and detailed design documents require approval by the contractor's responsible engineer and acceptance by the project engineer. These individuals are required to review the design concepts but are not expected to undertake a full check of every detail. Their roles are defined by Network Rail¹⁰ as follows:
- *The CRE is the person within a design and/or construction organisation contracted to Network Rail, (or to a party other than Network Rail where agreed with Network Rail) with accountability for the day-to-day management and co-ordination of the technical and engineering activities within a specific engineering discipline for a specific contract.*

⁸ A plan showing the layout of signalling equipment on the track, using red, green and black colours to signify new work, equipment to be removed and existing equipment remaining unaltered respectively.

⁹ A part of the signalling design which details all the conditions which must be met in order for the signallers' requests to be accepted by the interlocking.

¹⁰ Network Rail standard NR/L2/INI/02009 Engineering Management for Projects.

- *The project engineer is a person appointed by Network Rail accountable to the designated project engineer [a senior project engineer who oversees all disciplines] for day-to-day management and co-ordination of technical and engineering aspects of a project for a single engineering discipline.*
- 40 Signalling designs are also checked to ensure compatibility with work by other disciplines, such as track or civil engineering, before being approved for construction. These checks were not relevant to the accident as all the causal factors of this accident were related to the signalling discipline.
 - 41 Once checked and approved, several copies of the control tables, scheme plans and detailed design documents are issued. These include construction copies for the use of installers, testing copies for the testers and maintenance copies for use by Network Rail staff and others during the lifetime of the installed equipment. When, as at Waterloo, works are to be constructed in several stages (paragraph 58), separate sets of construction, testing and maintenance documents are provided for each stage.
 - 42 Equipment, including relays and wiring, is fitted by installers using the construction copies of the detailed design documents.
 - 43 Testing is managed by the tester in charge, whose duties include preparing a test plan based on the scheme plan, control tables and detailed design documents. This test plan is required to be checked, in detail, by a different person with a tester in charge certificate of competency. The role of the tester in charge is defined in the signalling works testing standard¹¹ as the person 'responsible for the production and implementation of the test plan' as well as the 'organisation, control and satisfactory completion of the testing'.
 - 44 The test plan is then accepted by the testing and commissioning engineer, a Network Rail employee with responsibilities for appointing senior project testing staff and reviewing testing documentation.
 - 45 The testing comprises three elements, each of which must be undertaken by a different person or different team:
 - verification, undertaken by verification testers, during which the installed relays and wiring are visually compared to the detailed design documents;
 - functional testing, undertaken by functional testers, during which the electrical operation of installed relays and wiring is checked against the detailed design documents; and
 - principles testing, undertaken by principles testers using their knowledge of signalling principles.
 - 46 The signalling works testing standard includes section 4.6.4.2 titled: 'Testing led changeover (controlled by testing)'. This permits testers to ask installers to fit new wires and correct wiring errors to make the installed equipment consistent with the issued detailed design documents. The process does not permit the tester to undertake any design or installation work themselves and so maintains the necessary separation between these activities. When using this process, a different tester is required to undertake the associated verification, and to record this on the relevant detailed design documents, before functional testing is carried out.

¹¹ Network Rail standard NR/L2/SIG/30014/A110 Signalling Works Testing.

- 47 The competence assessment of staff undertaking design, installation and testing of Network Rail signalling equipment is managed through a combination of Network Rail procedures and a licensing scheme operated by the IRSE. The interface between the Network Rail processes and the licensing system is covered by Network Rail standard NR/L2/SIG/10160 'Signal Engineering: Implementation of IRSE Licensing Scheme - The Route to Competence'.
- 48 The IRSE licensing scheme covers railway signalling and telecommunications designers, installers, testers, maintainers and managers. For each of these roles, the IRSE specifies the skills, underpinning knowledge and experience requirements.
- 49 Individuals seeking to be licensed by the IRSE are required to undertake a two stage competence assessment process, carried out by IRSE approved assessors. The first stage involves an assessment in the workplace by a qualified and experienced workplace assessor. The second stage consists of an interview with a different qualified and experienced competence assessor. Evidence of suitable training and work experience must be provided by the candidate. If both assessors are satisfied, the assessment documentation, work experience and training evidence are submitted to the IRSE for approval. If these are acceptable, the IRSE issues a licence for the relevant category of work.
- 50 Licences are valid for five years and can be extended by a further five years following a check by a competence assessor that licensees are continuing to gain and record appropriate experience. At the end of a ten year period, a full single stage assessment is carried out by a competence assessor before a licence can be re-issued.
- 51 The individual testing licences cover a broad range of activities so certificates of competency are used to demonstrate that an individual has the technical skills and knowledge to carry out specific activities. The requirements for these certificates are defined by Network Rail standards NR/L2/SIG/30014/B410 'Signalling Works Testing Staff Competence Assessment' and NR/L2/SIG/30014/B110 'Signalling Works Testing IRSE Licensing Requirements'.
- 52 Employers' competency managers assess whether an individual has reached the required standard for each category on the certificate of competency by reference to their work experience and by interview. Certificates of competency generally last for two years and are renewed by a further review of experience and a further interview with an employer's competency manager.

Pre-construction infrastructure

- 53 The signalling at Waterloo is controlled from the Wimbledon area signalling centre through the Waterloo interlocking in the Waterloo relay room (paragraph 20).

- 54 The Wimbledon area signalling centre contains an entrance-exit (NX) panel which includes buttons representing the beginning and end of routes¹² through parts of the railway. The signaller (or a tester during testing) requests (calls) a route by pressing the appropriate buttons. The interlocking then checks whether any conflicting routes are already set. If the selected route is available, the interlocking then sets signals and points appropriately. The panel also contains switches, known as 'points keys', for each set of points. These can be moved between three positions. The central position allows the interlocking to move the points when routes are selected. The left and right positions manually select normal or reverse positions and prevent route setting requests calling the points to the opposite position.
- 55 The Waterloo interlocking is a 'free wired route relay interlocking' containing electro-mechanical relays. Wiring links these relays to each other and to equipment including points, signals and devices adjacent to the track. This allows the interlocking to operate equipment and to obtain information including the location of trains and the position of points. The arrangement of relays and wiring is intended to prevent the operation of points and signals if this could result in conflicting train movements. The arrangement is also intended to prevent trains being permitted to pass across points which are not locked in the correct position.
- 56 Equipment controlled by the Waterloo interlocking includes 1524 points. These comprise three pairs of point ends which need to be set and locked in the required normal or reverse position before trains can pass over them. When locked in these positions, detectors attached to the point ends allow electric current to flow in the appropriate (normal or reverse) detection circuits. The interlocking uses these circuits to determine whether the point ends are correctly set to allow the safe passage of trains.
- 57 The detectors on 1524 points are connected by electrical cables to a lineside cabinet (location case W14), and then into the Waterloo relay room (figure 10). Although 1524 points were not physically affected by the upgrade work, the arrangement of the point detection wiring between 1524 points and the relay room was modified when location case W14 was replaced in June 2017 (paragraph 59).

Signalling design work

- 58 On large engineering projects, particularly where the infrastructure needs to remain in use during construction, it is necessary to undertake construction in stages. In signalling design, the as-built drawings for one stage (which can vary from the design prepared for that stage) form the basis for the next stage of design. It follows that a stage of design cannot be finalised until the preceding stage has been installed and commissioned, and the as-built drawings completed.
- 59 The signalling work at Waterloo began in August 2015. In the period between then and August 2017, there were 13 stages. These included stage 11B in June 2017 when location case W14 was replaced and stage 5B¹³ which was in progress during the August 2017 blockade in which the accident occurred.

¹² A route is the path from an entrance point to an exit point on the signalling panel, set by the signaller pushing buttons in sequence. For a route to be tested the points in the route need to be available, ie not already required by a different route.

¹³ The signalling stages were not all numbered sequentially by the time of the August 2017 blockade.



Figure 10: Waterloo relay room with inset including connections from 1524 points and associated fuse holders as detailed in figure 19

- 60 The signalling design for stage 5B was undertaken by MML from late 2016 on the understanding that the work carried out in August 2017 would be done in a 24 day continuous blockade encompassing all areas required for this work, including areas unaffected by new construction but needed for signal testing. No regular train services were expected to operate in this blockade area. In a design review in October 2016, the signalling designers at MML realised that the blockade planned for August 2017 was limited to the area in which new works were being constructed (platforms 1 to 9 and the down and up main slow lines). They believed that the only viable alternative to increasing this planned area was to defer the capacity improvement works until a larger blockade area could be arranged.
- 61 The WCA project managers, MML and Network Rail began talks with other railway stakeholders in order to seek a larger area for the August 2017 blockade. In July 2017, these parties agreed the following plan:
- a 24 day blockade encompassing platforms 1 to 10, the down and up main slow lines and the down and up main fast lines;
 - possessions during the blockade period which extended the area available for signal testing at weekends and during mid-week nights; and
 - the production of a design splitting methodology (paragraph 153) to specify which parts of the signalling modifications could be implemented at each stage of the blockade.

- 62 The capacity improvement works required replacement of signalling location case W14 which contained detection circuits for 1524 points. This work included alterations to the detection circuits for 1524 points so that they were in accordance with modern design practice. MML completed the design of this work in March 2017.
- 63 The signalling design for the August 2017 blockade was completed and approved for construction in July 2017. It was not possible for this stage of the design to be completed until the previous stage of the capacity improvement works had been installed and tested in June 2017.

The test desk

- 64 MML was responsible for designing the changes to the interlocking. In order to test the changes to the interlocking without conflict with other disciplines and within the time available, OSL identified the need for a test desk to simulate the operation of railway infrastructure, including simulating inputs from point detectors. Following discussions between members of the WCA and OSL, it was decided that OSL was best placed to resource the design of the test desk.
- 65 MML issued OSL with copies of the detailed design documents for the interlocking in late spring 2016 so that OSL could design the test desk. OSL testers prepared a list of the functions which they required to be simulated by the test desk. This included functionality to simulate movement of 1524 points.
- 66 Design and checking of the test desk was completed by OSL in June 2016 (paragraphs 105 to 110). The test desk comprised a switch panel (the controls used to simulate operation of railway infrastructure) connected to an isolation rack which was attached to the interlocking by spur wires (figures 11 and 12).

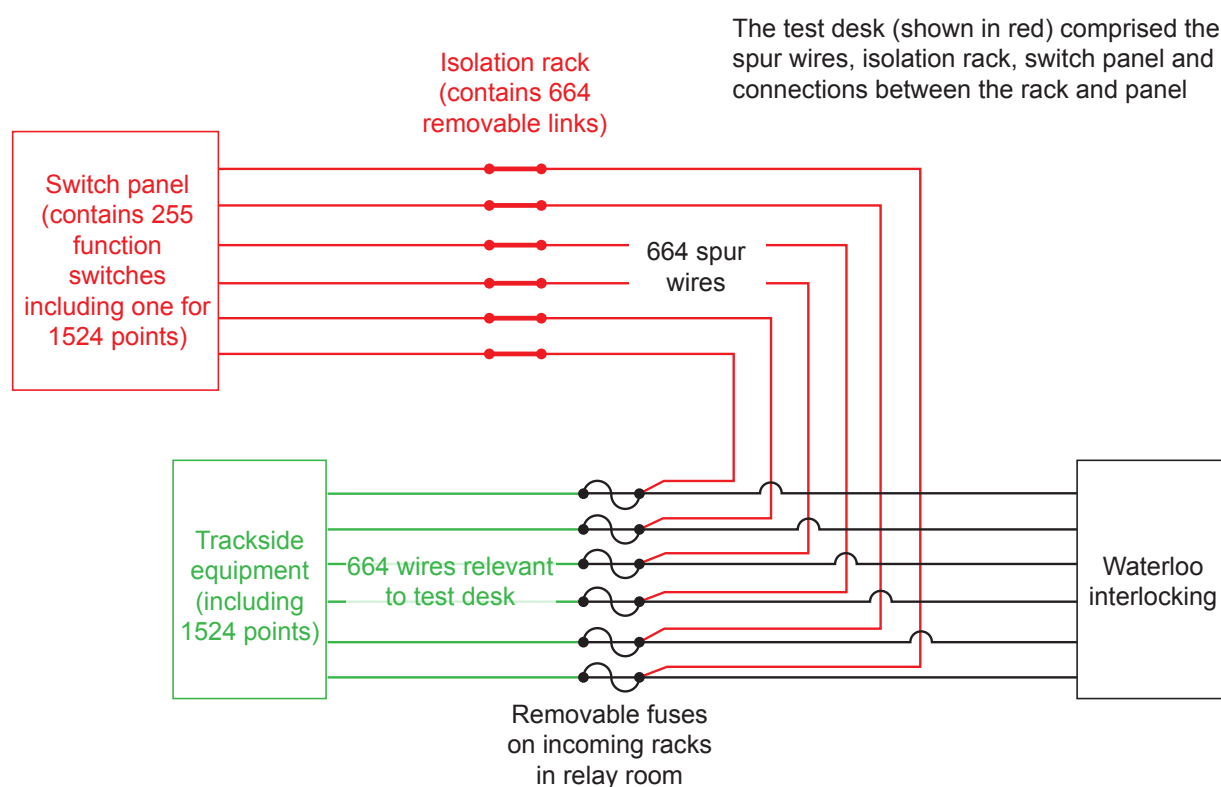

Figure 11: Block diagram of the test desk and connections

- 67 The spur wires were connected to the interlocking side of fuse holders on circuits linking the interlocking to trackside equipment. These wires remained connected to the interlocking fuse terminals at all times. Testers removed fuses and inserted links in the isolation rack to allow the interlocking to respond to the simulated inputs from the test desk switch panel, and not to trackside equipment. Once testing was complete, removing the links from the isolating rack disconnected the switch panel from the interlocking and re-inserting the fuses caused the interlocking to respond to inputs from trackside equipment.

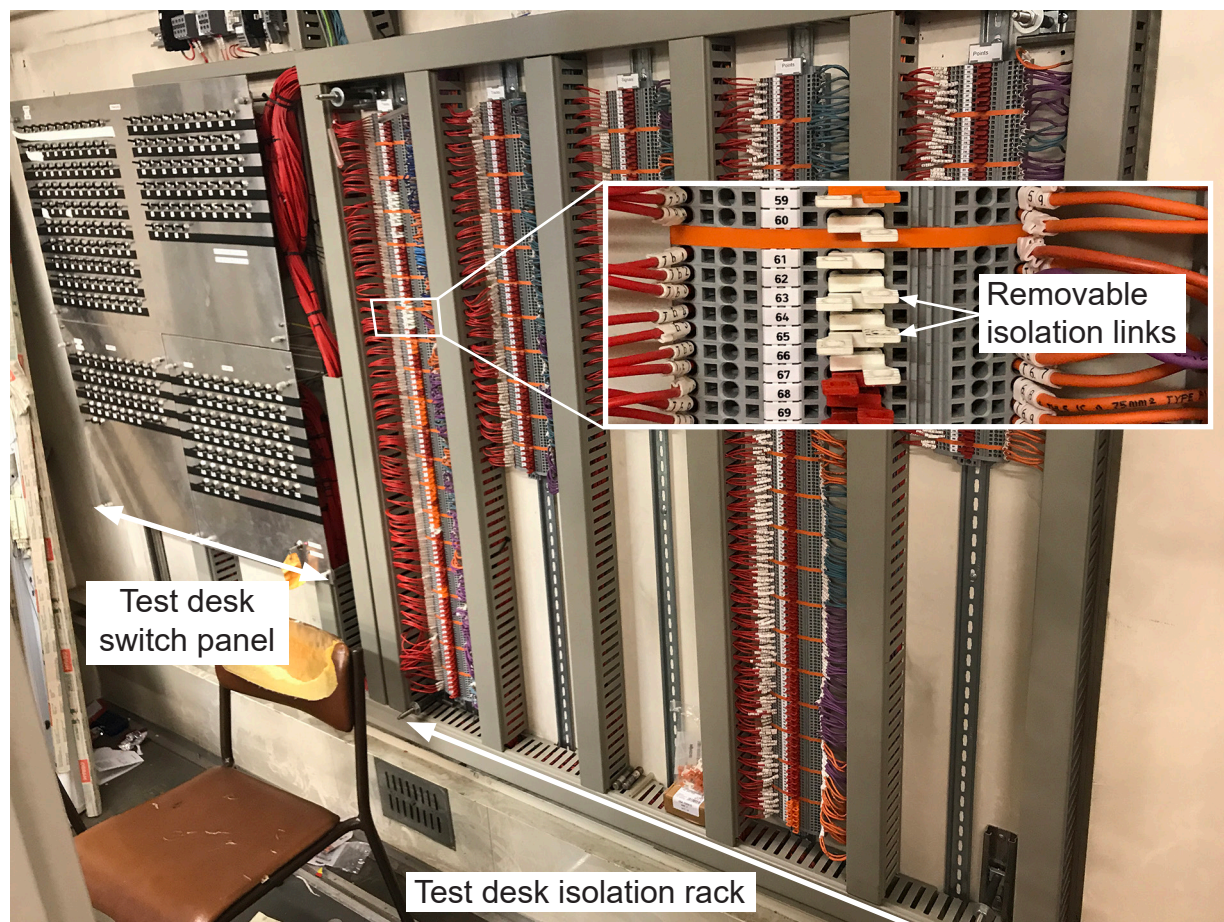

Figure 12: Test desk switch panel and isolation rack in Waterloo relay room. White links are conductive, red and orange links are dummy (isolating) links which are fitted to prevent unintentional fitting of conductive links.

- 68 Removal of appropriate isolating links meant that the switch panel and its connections to the isolation rack were disconnected when the associated parts of the interlocking were in operational use. Disconnection of the test desk when the interlocking was in operational use meant that the switch panel and these connections met Network Rail requirements for testing equipment which could be used under the control of the TIC (paragraph 69) and there was no requirement for them to be shown on the detailed design documents for the interlocking. The spur wires remained connected to the interlocking when this was in operational use and so fell outside these requirements for testing equipment which could be used under the control of the TIC. The spur wires fell within Network Rail's definition of temporary works and so were required to be shown on the interlocking detailed design documents (paragraph 70).

- 69 Testing equipment which should be under the control of the TIC is described in paragraph 4.11.1 of the signalling works testing standard. The relevant extracts of the standard are:

The following simulation products shall be strictly controlled by a management system under the control of the Tester in Charge.

- *Test wiring and equipment,*
- *Dummy loads... [and]*

...Simulation products shall only be connected and energised when required during the testing activity.

- 70 The spur wiring was temporary works as described in module A16 of the signalling design handbook. It formed part of 'Stagework at installations with a very limited life expectancy', one of the examples of temporary works given in paragraph 2 of module A16. Paragraph 5 of this module required that:

whilst the temporary arrangements remain in place...all the relevant diagrams, including analysis, cable core plans and bonding plans, should be produced and issued for production, testing, commissioning and maintenance purposes [with an exception not applicable to the test desk].

The listed documents are part of the detailed design documents and, as the spur wires were connected to electrical components of the interlocking, the detailed design documents for the interlocking are among the 'relevant diagrams'.

Implementation

- 71 Implementation of the capacity improvement works started in November 2015. The test desk was connected to the interlocking in August 2016 and at that time it correctly simulated the operation of 1524 points. Work in June 2017 included replacement of location case W14 and modifying the detection circuits for 1524 points to bring them in line with modern design standards.
- 72 The August blockade commenced on 5 August 2017 and continued until 29 August (after the accident). The blockade area included platforms 1 to 10 and four main lines on the station approach. The C ends of 1524 points were within the blockade, beneath the engineering train. The A and B ends were outside the blockade and were required to remain in the normal position to allow trains to run between the up main relief line and platforms 11 to 14.
- 73 The area available for signal testing was extended beyond the blockade during a weekend possession which started at 00:40 hrs on Saturday 12 August. This possession included the up main relief line, 1524 points and other lines. After the possession started, 1524 points were disconnected from the interlocking. Inputs from these points to the interlocking were then simulated using the test desk allowing testing of routes over these points.

- 74 At around 10:00 hrs on 13 August 2017, a principles tester (paragraph 45) at Wimbledon area signalling centre was testing routes with some inputs, including inputs from 1524 points, being simulated by another person operating the test desk at Waterloo relay room¹⁴. When 1524 points were switched to the reverse position, the C ends of these points were not shown as detected on the Wimbledon signallers' display. This was apparent to the principles tester because indicator lights on the display indicated 'out of correspondence' and that the C ends detection circuit was incomplete.
- 75 The principles tester contacted the functional tester (paragraphs 16 and 45), who was at Waterloo relay room, by mobile telephone and asked him to resolve the problem. After checking the available drawings, the functional tester devised a solution which was implemented and resulted in the signallers' display at Wimbledon showing that 1524 points were correctly detected when the test desk was being used to simulate inputs from these points. This is evidenced by a signalling data logger in Waterloo relay room which had recorded the C ends out of correspondence with the A and B ends until 12:46 hrs on 13 August. It then recorded all point ends detection relays operating in unison. After implementation of his solution, the functional tester asked the principles tester to check that the indications at Wimbledon were correct, and the principles tester confirmed that they were.
- 76 There is conflicting evidence about how much information the functional tester provided to the principles tester about the work done to alter the effect of the test desk operation. The functional tester stated that he described the work to the principles tester. The principles tester stated that he received limited information and did not check the solution adopted by the functional tester. The absence of a check by the principles tester is consistent with the requirements of the signalling works testing standard which requires functional testing to be independent of principles testing.
- 77 Testing of routes over 1524 points then continued throughout the day and into the night shift. The possession, which included the up main relief line, was given up at 04:50 hrs on Monday 14 August. The functional tester's solution was not removed when the interlocking was returned to operational use (paragraph 142).
- 78 Regular train services then ran over 1524 points throughout 14 August. These services (and all regular train services during the blockade) required 1524 points to be in the normal position. The detection circuits provided the interlocking with the 'normal position' indication required for the signaller to set routes over these points. No-one was aware that the detection circuits were not providing reliable information (paragraph 96). It is likely that 1524 points were set and locked in the normal position because they were in this state before the possession started on 12 August and had not been moved during the possession. The point motors were disconnected¹⁵ during this possession while testing was undertaken.

¹⁴ Although the test desk was designed and the test plan approved before it was decided that the engineering train would remain over 1524C points during testing, the test desk design included the simulation inputs needed with the train in that position. The decision to use the test desk with the engineering train over 1524C points should not have affected railway safety.

¹⁵ Disconnection was achieved by removing the fuses from the points motor drive circuits.

- 79 Another possession started at 01:20 hrs on Tuesday 15 August and included the up main relief line, 1524 points and other lines. This was to allow further testing of the modified signalling including testing of some routes which would require 1524 points to be called reverse or normal. There was no requirement for 1524 points to move or be detected in the reverse position during this testing so no measures were taken to simulate operation using the test desk and no measures were taken to disconnect the points detection and point motors from the interlocking.
- 80 The testers believed that, as stated in the signalling test plan (paragraph 156), all ends of 1524 points were secured by fitting scotches and padlocked clips to the rails and by electrically isolating the point motors. The testers did not transfer the detection of 1524 points to the test desk and the interlocking remained connected to the external point detectors. These testers were not aware of the uncontrolled wiring fitted when the functional tester's solution was implemented (paragraph 75).
- 81 During a period of around six minutes at around 01:40 hrs, the points were twice called reverse and then normal. The A and B ends of the points moved during this period because, contrary to the testers' belief, these ends were not secured¹⁶. The testers were not aware of this and did not notice anything unusual about the indications on the signallers' panel at Wimbledon. Their testing did not require them to monitor these indications.
- 82 The possession which had started at 01:20 hrs was given up later that morning at 04:42 hrs, one hour before the accident.

Identification of the immediate cause

83 **The train was signalled to run over a set of points which were not correctly positioned for the passage of the train.**

- 84 Images from the passenger train's forward facing CCTV show a green signal with a 'UR' indication displayed adjacent to this (figure 7). This gave the driver authority to proceed out of platform 11 and along the up main relief line, the line running alongside the engineering train. The correct indications for this authority were shown on the signallers' display at Wimbledon area signalling centre (figure 6).
- 85 Less than a minute after the signal turned green, the train was approaching 1524 points and images from the train's CCTV showed the points in an intermediate position between the reverse position and the intended normal position (figure 8).

¹⁶ 1524 points were able to move despite the engineering train occupying a track circuit that would normally have locked them. This was because input from this track circuit was among those being simulated by the test desk.

Identification of causal factors

- 86 The accident occurred because uncontrolled wiring was added to points detection circuits, such that the position of 1524 points was incorrectly detected (paragraph 87). This wiring was added during testing when the test desk was found to no longer simulate the detection of 1524 points correctly. The factors that led to this unsafe outcome were:
- the test desk did not function as expected because of an incomplete design process (paragraph 102);
 - the actions taken to make the test desk simulate the operation of 1524 points correctly were not in line with the signalling works testing standard, and uncontrolled wiring was not removed before train services restarted across 1524 points (paragraph 130);
 - the actions of the functional tester were inconsistent with the competence expected of testers (paragraph 145); and
 - 1524 points had not been secured in the normal position by disconnecting the points electrically and fitting scotches and padlocked clips, as had been required by the test plan (paragraph 152).

Each of these factors is now considered in turn.

Wiring of the points detection circuits

87 Uncontrolled wiring was added to points detection circuits, such that the position of 1524 points was incorrectly detected. This wiring was added during testing when the test desk was found to no longer simulate the detection of 1524 points correctly, a consequence of an incomplete design process.

- 88 The original and new interlocking arrangements were designed so that the proceed indications seen by the driver (paragraph 29, figure 7) would only be displayed if the A, B and C ends of 1524 points were locked and detected in the normal position. The detection relays for these point ends were in the Waterloo relay room where a data logger recorded them detecting these point ends as locked in the normal position when the accident occurred. The accident occurred because the A ends were in an intermediate position, not the normal position (figure 8).
- 89 The following paragraphs use a simplified description of the detection system to show how wiring added on 12 August 2017, described throughout as ‘uncontrolled wiring’, caused the incorrect detection of the 1524 point ends. The position of each set of point ends was detected using electrical position switches known as detectors. These detectors allowed current to flow through detection circuits when the point ends were locked in the appropriate position. Separate detectors were provided for the left and right rails of each set of point ends and for the normal and reverse positions. The simplified description combines the left and right rail detectors at each set of point ends into a single detector. The diagrams (figures 13 to 18) only show detection for the normal position: the reverse detection circuit (not shown) contains the same elements.

- 90 Only one uncontrolled wire is shown on the simplified diagrams but four wires were actually added on 12 August 2017. This was because an uncontrolled wire was actually added to the outward and return portions of both the normal and reverse detection circuits (see appendix C for full wiring diagram).
- 91 Before the works began, the point detectors for each of the three ends were wired in series, meaning that all three ends had to be in the same position before any current was returned to the normal or reverse detection relays (figure 13). This current was then used to energise the appropriate relays designated 1524A/B and 1524C. Although designated A/B and C, these relays were fed by detection circuits passing through all three point ends. Further circuitry in the interlocking required the detection relays to be energised before signals could display a proceed aspect to permit trains to approach 1524 points.

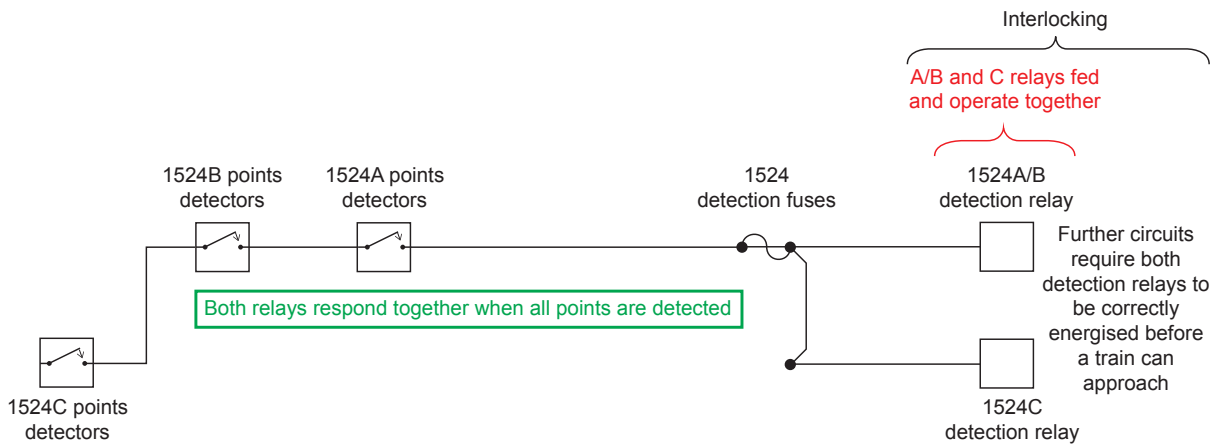
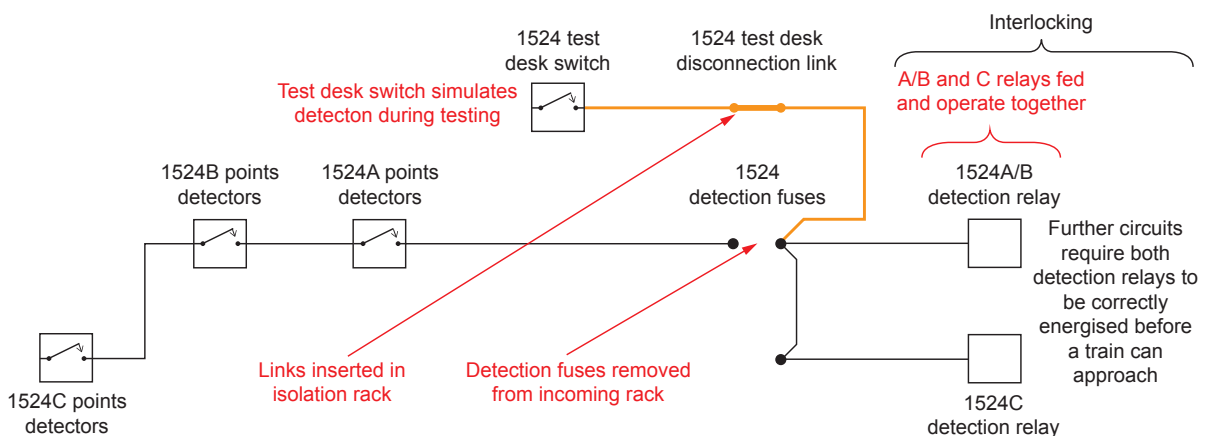

Figure 13: 1524 points detection before work began

- 92 When the test desk was installed in August 2016, spur wires were attached to the detection fuse terminals which fed both 1524A/B and 1524C detection relays. When used to simulate the operation of 1524 points, the test desk correctly energised these relays (figure 14).



Note: when not in test mode (ie when interlocking in operational use) links removed and fuses inserted

Figure 14: 1524 points in test mode, before location case W14 was replaced

- 93 The detection wiring from 1524 points passed through location case W14. When this was replaced in June 2017 (paragraph 71), the wiring was altered so that A and B detection circuits energised only 1524A/B detection relays and the C end detection circuits energised only 1524C detection relays (figure 15). As before, further circuitry required both detection relays to be energised before trains were permitted to approach 1524 points.

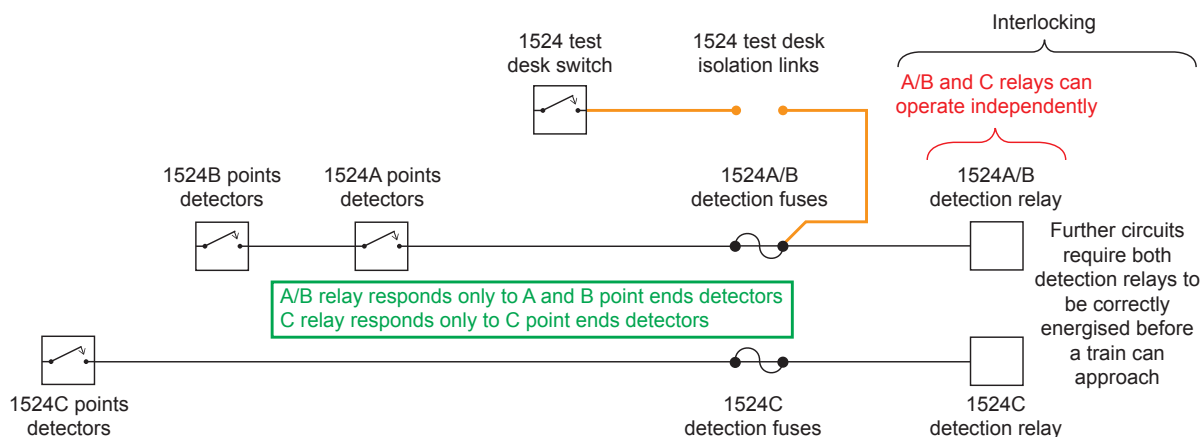

Figure 15: 1524 points detection after location case W14 was replaced (no uncontrolled wiring)

- 94 These modifications to the wiring of 1524 points detection (paragraph 71) did not affect the safety functions provided by the interlocking but did mean that the test desk no longer simulated the detection of 1524 points correctly because 1524C point ends were no longer connected to it (figure 16). This would not be apparent until testers required the test desk to simulate the position of the points.

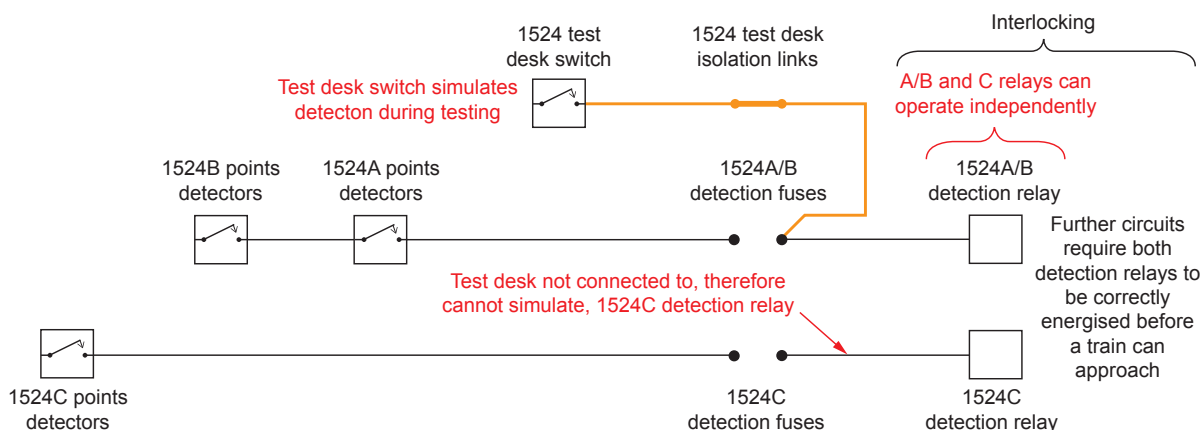

Figure 16: 1524 points in test mode after replacement of location case W14 (no uncontrolled wiring)

- 95 The absence of simulation from the test desk for 1524C point ends became apparent during testing at Wimbledon on the morning of 13 August (paragraph 74). The solution to this problem adopted by the functional tester (paragraph 75), involved installation of uncontrolled wiring linking the terminals of 1524A/B and 1524C detection fuses (figure 17). Simulated input from the test desk now operated 1524A/B and 1524C detection relays.

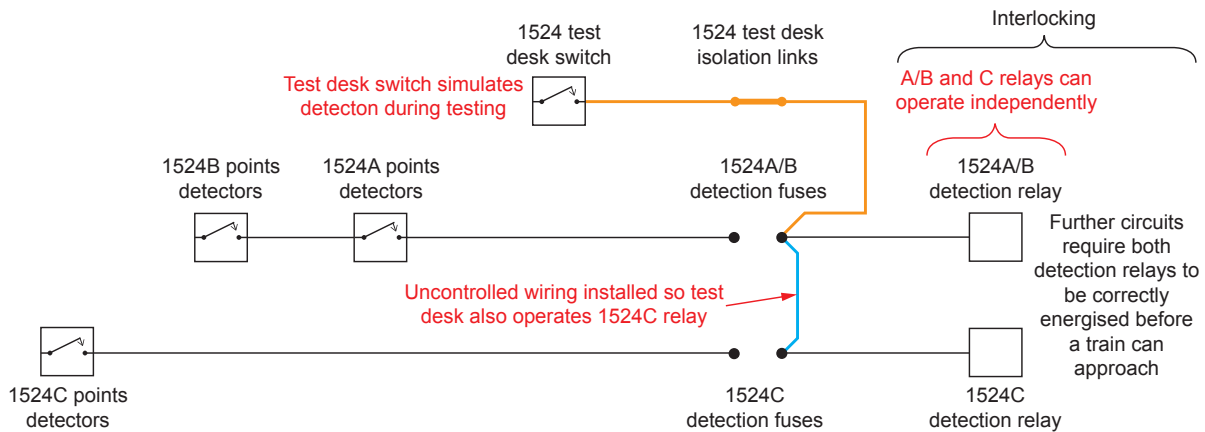

Figure 17: 1524 points in test mode after replacement of location case W14 and addition of uncontrolled wiring

- 96 The uncontrolled wiring had been added during a possession which ended at 04:50 hrs on 14 August. When this possession ended, 1524 points were returned to service with detection configured so that, among other possible false indications, the C ends normal detectors would feed current to the normal detection relay for A/B ends irrespective of the position of A/B ends (figure 18). Similarly, the A/B ends reverse detectors would feed current to the C ends reverse detection relay irrespective of the actual position of the C ends. This was not immediately apparent, as the points had remained in the normal position required for regular train services during the testing on 13 and 14 August (paragraph 78).
- 97 During the night of 14/15 August, signalling testers at Wimbledon were checking signalling routes into Waterloo station. Some of these routes required 1524 points to be called reverse. To allow this, the key for 1524 points on Wimbledon panel was turned to the centre position from the normal position required when train services ran during the blockade period.
- 98 When 1524 points were called reverse, the A and B ends moved to the reverse position because, unlike the situation on 13 and 14 August, the point motors were now connected to the interlocking (paragraph 81). The C ends were secured and remained in the normal position. As a result of the uncontrolled wiring in the relay room (figure 18), once A and B ends reached the reverse position the detection relays for all three ends were energised.

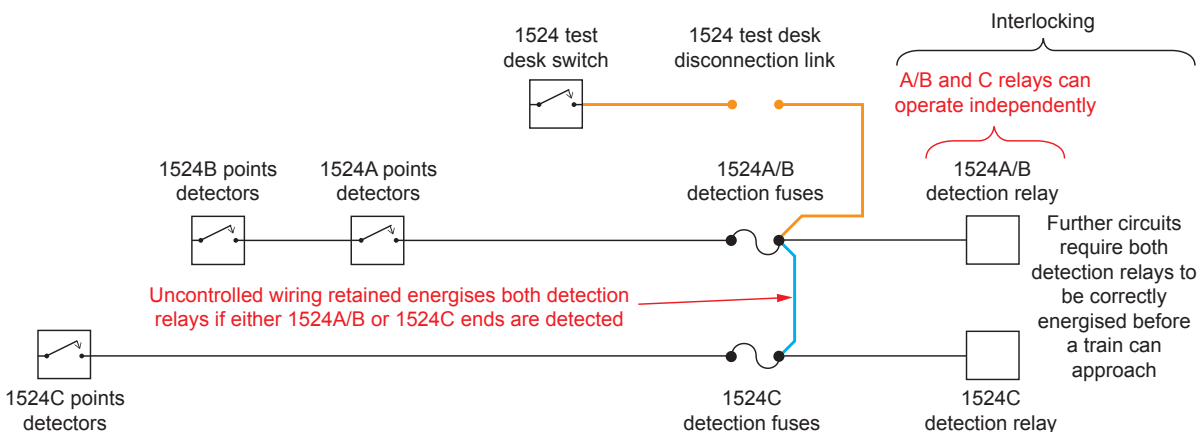

Figure 18: 1524 points detection at time of derailment

- 99 The testers then cancelled the route and returned the points key to the normal position. This caused point ends 1524A and 1524B to begin to move towards this position. Additional circuitry, not included in the simplified description above, prevented the current from the normal position detectors reaching the normal detection relays while the points were called reverse. This circuitry correctly ceased to be effective when the points were called normal and the A and B ends moved away from the reverse position.
- 100 As the C end had remained in the normal position, current from the C end detector now correctly energised the 1524C normal detection relay and, because of the uncontrolled wiring, incorrectly energised the 1524A/B normal detection relay. The incorrect detection of A/B ends in the normal position cut the power to the point motor before these ends reached the normal position. This left the point ends unlocked and in an intermediate position (figure 8).
- 101 When left unlocked, the unrestrained switch blades of the points tended to move to, and remain at, a position midway between normal and reverse. They could be pushed to either of these positions by trains trailing through the points, as happened shortly before the accident (paragraph 28), but would then return to the intermediate position.

Implementation of the test desk design process

102 The test desk did not function as expected because of an incomplete design process.

- 103 Had the test desk design been kept up to date with changes to the interlocking design, it would have functioned correctly when used to simulate 1524 points. If the test desk had functioned correctly, the functional tester would not have been requested to find a solution, which resulted in the uncontrolled wiring.
- 104 The test desk design was incomplete, and so did not provide the required functionality, because:
- the test desk design did not allow for changes to the interlocking design after completion of the test desk design (paragraph 105);
 - temporary spur wires forming part of the test desk were not shown on the interlocking drawings, an omission which probably led to the lack of recognition that the test desk design needed updating (paragraph 116); and
 - no risk assessment was prepared for the temporary spur wiring (paragraph 126).

Each of these issues is now considered in turn.

The test desk design

- 105 The test desk was completed in June 2016 based on copies of the interlocking design documents provided to OSL by MML for that purpose. OSL stated that it was given verbal assurance by the CRE that the interlocking circuits affecting the test desk would not alter from the arrangements shown in these interlocking design documents. However the CRE did not recall this conversation. In fact, interlocking design changes affecting test desk operation were made in March 2017 in connection with the replacement of location case W14 (paragraph 71).

- 106 OSL requested that the test desk design was subject to the same approval and acceptance process as other signalling design. This was because the test desk's spur wires remained attached to the interlocking while it was in operational use. The need to apply this process was also recognised by Network Rail's testing and commissioning engineer in an email sent to the project engineer and CRE in which he described the wiring as 'intrusive' to the interlocking. The test desk design was approved by the CRE in July 2016 and accepted by the project engineer in August 2016.
- 107 The CRE stated that, at the time the test desk was designed, he did not realise that the changes made during subsequent stages of the interlocking design would affect the operation of the test desk.
- 108 The project engineer recognised the possibility that the interlocking design could change as there were several stages due to be designed after OSL submitted the test desk design. In an email dated 4 August 2016 he asked the CRE why there was no process to ensure that the MML (interlocking) and OSL (test desk) designs remained compatible. The project engineer stated that the CRE responded to him with the assurance that the test desk wiring was being managed by the TIC, so no other process was required to keep the test desk design current.
- 109 After receiving this assurance from the CRE and noting that the test desk methodology document specified that the test desk design and its interface with interlocking circuits were the responsibility of OSL, the project engineer accepted the design of the test desk. The test desk methodology did not contain any provision for updating or reviewing the design to maintain its compatibility with the interlocking design and the project engineer did not require the introduction of such a process. The project engineer stated that he was not under time or other pressure when accepting the test desk design.
- 110 Network Rail has a process for managing concurrent design activities by two organisations working in the same area on two projects, as documented in Module A22 of the signalling design handbook 'Management of Overlapping and Parallel Signalling Design'. This process required a designated individual to check that design changes generated by one project were updated in all concurrent projects. The process did not apply at Waterloo because OSL and MML were both working on the same project with design control undertaken by the same CRE. Co-ordination within a project is not covered by a detailed Network Rail process and relies on the expertise of the staff managing and undertaking the work, an approach which allows staff to implement a process which takes account of individual project requirements.
- 111 OSL designers did not have the information needed to manage co-ordination between the test desk design and development of the interlocking design. They were not issued with updated versions of the interlocking design and have stated that they understood there to be no changes to the interlocking which would affect the test desk (paragraph 105).
- 112 An email from the project engineer to the CRE indicates that both were aware of the need to consider possible interaction between the evolving interlocking and the test desk design. However, their actions (paragraphs 107 to 109) did not achieve effective co-ordination.

- 113 Testing managers at OSL stated that they only realised just before the August blockade that the test desk design was out of step with the interlocking design due to wiring changes made to the interlocking during the preceding construction stages. They were not aware of the specific issue at 1524 points.
- 114 OSL testing managers also stated that they believed that, if this resulted in any issues with the operation of the test desk, these would be minor and could be rectified by testers during the testing work. They assumed that any changes would be developed by testers and applied to parts of the test desk separated from the interlocking by the isolation links. Such changes would be made during testing and marked up on the test desk drawings.
- 115 The testing managers did not take steps to inform all testers or other WCA staff of the possible need to modify wiring due to the test desk design being out of step with the interlocking. However, the managers would have expected the testers' actions to be in accordance with Network Rail procedures and be permissible because the changes would not have affected the interlocking when the isolation links were removed while the interlocking was in operational use (paragraph 68).

Test desk spur wires

- 116 The spur wires connecting the interlocking to the test desk isolation rack were not shown in MML's detailed design documents for the interlocking. If they had been shown, it is likely that, when they were designing the revised detection circuits for 1524 points in March 2017, MML staff would have realised that their modifications would affect the test desk wiring and taken action which would have resulted in the OSL design being modified.
- 117 OSL stated it expected that, once the test desk design had been approved by the CRE and accepted by the project engineer, MML would show the spur wires on the interlocking detailed design documents and schedules. This would have been consistent with Network Rail processes (paragraph 70). The CRE's coordination role meant that, when he approved the test desk design, he should have put arrangements in place to ensure that wires shown on this design were, where necessary, included on other detailed design documents.
- 118 The requirement for the CRE to approve the test desk detailed design arose only because parts of it (the spur wires) remained attached to the operationally active interlocking. There would have been no requirement for him to approve these documents if all test desk parts, including the spur wiring, were disconnected from the interlocking in these circumstances.
- 119 The CRE stated that he believed that the test desk, including the spur wires, would be disconnected from the interlocking when this was in operational use. If disconnected in these circumstances, the spur wires would have been under the control of the TIC with no Network Rail requirement for these wires to be shown in the interlocking detailed design documents (paragraph 69). However, the spur wires remained connected to the interlocking when it was in operational use, and so should have been considered as temporary work and shown on the detailed design documents for the interlocking (paragraph 70).
- 120 The CRE stated that his belief was based on project team discussions in which the test desk was described as 'disconnected' when not in use.

- 121 When approving the test desk detailed design documents, the CRE approved 65 sheets including 42 wiring sheets showing a total of 664 connections between the spur wires and the interlocking (figure 11). These connections were shown in the same way as permanent connections shown by MML on its own interlocking detailed design documents. There was nothing to imply that the spur wire connections were short term. The 42 sheets showing the spur wire connections also showed the isolation links. These links were attached to one end of each spur wire and would not have been necessary if the opposite end of the spur wires were detached when the interlocking was in operational use.
- 122 The test desk detailed design documents also included five sheets of operations schedules. These schedules tabulated the interlocking fuses and test desk isolation links which were to be inserted and removed to connect and disconnect the test desk switch panel. These schedules made no reference to disconnecting the spur wires from the interlocking when the interlocking was in operational use.
- 123 MML stated that it was unaware until after the accident that the spur wires remained connected to the interlocking while it was operational. MML and the CRE have also stated they do not consider that the spur wires were temporary wires when connected to the operational interlocking.
- 124 The omission of the spur wires on the MML interlocking drawings should have been raised as an issue during testing of previous stages of the work. Test copies of the design documents show that checks were carried out by testers on interlocking terminals fitted with spur wires. These checks should have identified more wires than shown on the interlocking drawing and the testers should have raised this issue on a test log. The test log should then have been sent to MML's designers in order to resolve the anomaly. No test logs were raised for this issue. It is uncertain whether this would have led designers to recognise the mismatch between the test desk design and the interlocking arrangements after the replacement of location case W14.
- 125 The project engineer understood that the spur wires were to be attached to the interlocking for the duration of the Wessex capacity improvement project, but did not notice that they had not been added to the interlocking detailed design documents when he reviewed these several months after accepting the test desk detailed design. The agreed acceptance timetable for WCA design was faster than normal (10 working days rather than 20) but there is no evidence that this was a factor in the accident because the project engineer stated that his acceptance reviews were compliant with Network Rail standards and the engineering management plan for the project.

Risk assessment

- 126 The signalling design handbook (Module A16) required a fully documented process of risk assessment to be undertaken for temporary works attached to a signalling system when this was in operational use. Paragraph 1 of module A16 requires that a risk assessment should include consideration of:
- *the time for which the work may remain; and*
 - *the likelihood of future alterations to the temporary work.*

- 127 Although the spur wires were temporary works (paragraph 70), no risk assessment was carried out for these. The CRE stated that he did not request one because of his understanding that the spur wires would not be left connected to the interlocking while this was in operational use.
- 128 The project engineer was aware that the spur wires would be attached to the interlocking when this was in operational use. He stated that he was confident that the management of the test desk issues was covered by the collaboration and understanding between the various parties. He believed that the two elements of design having the same CRE would ensure that things would be kept in line. As a consequence he did not apply the requirements of the temporary wiring standard which included a risk assessment.
- 129 Had a risk assessment of the spur wires been carried out, the risk of changes to the interlocking after completion of the test desk design should have been identified and mitigated. This should have resulted in a design coordination process leading to the updating of the test desk design.

Signalling works testing activities, and the return to service

130 The actions taken to make the test desk simulate the operation of 1524 points correctly were not in line with the signalling works testing standard, and uncontrolled wiring was not removed before train services restarted across 1524 points.

- 131 The functional tester was in the Waterloo relay room when his actions resulted in the test desk simulating 1524 points as expected. The expected simulation was achieved by the addition of four blue wires to the 1524 points detection fuse terminals located in Waterloo relay room (figures 17, 18 and 19, appendix C).
- 132 When asked to resolve the problem with the test desk by the principles tester (paragraph 75), the functional tester referred to maintenance copies of design documents available in the relay room and deduced that the problem was likely to be a consequence of wiring changes made during earlier parts of the project. He then asked for testing copies of these documents as testing copies identify changes made during stages of work. The documents he received did not cover the equipment in the relay room.
- 133 Although the maintenance copies of the documents contained the information needed to develop a correct solution, the functional tester stated that he developed a solution by examining the wiring which had already been installed in the relay room. He did not contact the TIC or ask for assistance from on-call signalling designers to resolve the problem. Although the on-call designers were MML staff, so were not familiar with the test desk design, they did know about the changes to the points detection circuits.
- 134 The functional tester stated that, when developing his solution, he did not realise that the detection circuits for the C ends of 1524 points had been separated from the circuits for the A and B ends (paragraph 93). His understanding was that, as a result of the work associated with replacing location case W14, the combined detection circuits were now connected to a different set of terminals. The functional tester therefore intended to reconnect combined incoming circuits to their original terminals where the test desk was connected.

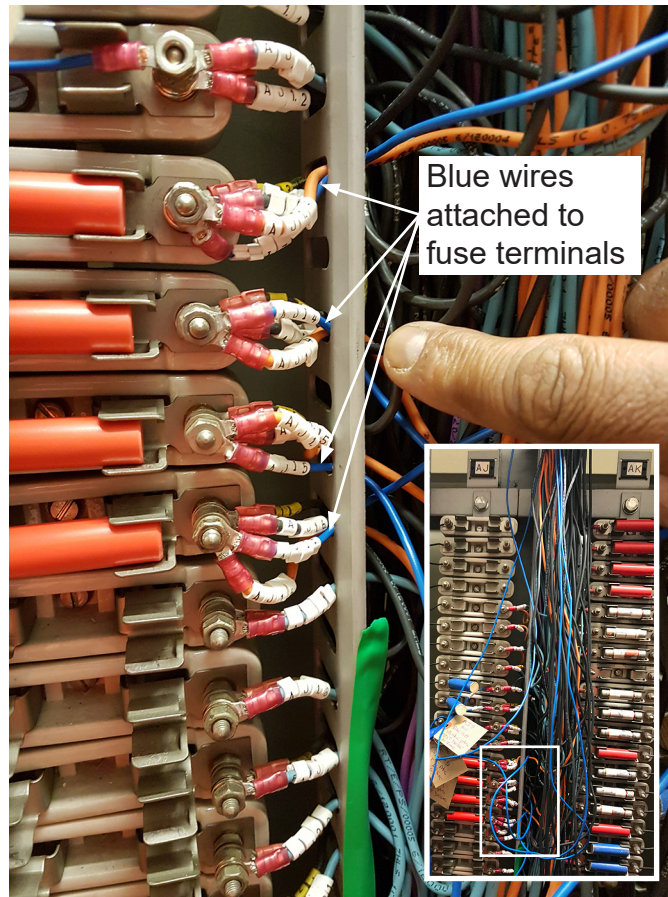

Figure 19: Uncontrolled wiring attached to the fuses for 1524 points detection relays

- 135 The functional tester had based his approach on a similar modification made by another tester on 1514 points. He did not realise that this wiring was applied to points that were inside the blockade area. A test log¹⁷ had been raised for the wiring on 1514 points reminding the TIC to remove these wires before 1514 points were returned to operational use. Handback processes applicable to the end of the blockade (programmed for 29 August) meant that 1514 points should not have been returned to operational use until this test log had been closed by recording the removal of the wires.
- 136 The uncontrolled wiring was fitted when work in the relay room was intended to be carried out using the testing led changeover process (paragraph 46). This means that installers should have fitted wires in accordance with detailed design documents when instructed by a tester. WCA installation managers reported that there were two installers working in the relay room during the day shift when the uncontrolled wiring was installed on 13 August.

¹⁷ A test log is a written record of any change or discrepancy noted during the signalling testing process. The TIC should either close or defer, if safe to do so, every test log before the railway can be returned to operational use.

- 137 The process for fitting wires in the relay room on 13 August, as described by both installers, was that a tester would write two 'luggage labels', each showing the origin and destination of a wire. The installers then worked as a pair to run each wire between the terminals shown on the labels. Once complete, a different tester would check the electrical continuity of the wire, and the position of each end, against the relevant drawing in the detailed design documents. Other testers were available to undertake such checks in the relay room during the day shift on 13 August.
- 138 There is conflicting evidence about the installation of the uncontrolled wiring which, as with other test desk connections to the interlocking, was a different colour to the standard black interlocking wiring. The functional tester stated that he instructed an installer to add blue wiring to the detection circuits for 1524 points and that, once complete, he asked the installer to add labels to the wires to show their purpose. The functional tester stated that no labels had been written out as the installers had not been able to find any labels.
- 139 The two installers also stated that they usually took breaks at the same time and remained together during the shift. The RAIB has examined the site signing-in and signing-out records. These have some omissions, but show that one of the installers was away from the site containing the relay room when the relays began working together at 12:46 hrs (this time was recorded by the relay room data logger, paragraph 75). It is likely therefore that the installers were not present, and were probably on their lunch break, when the uncontrolled wires were fitted. The site signing-in records also confirm that the functional tester was on site when the relays began working together.
- 140 Both installers stated that they had not installed any blue wires during their work in Waterloo relay room. They also stated that they could not have fitted wires without labels as, without these, they would not have known where to run the wires to and from. This evidence, together with the signing-in and out records, indicate that it is likely that the uncontrolled wiring was installed by the functional tester.
- 141 There is no evidence that the installation of uncontrolled wiring was recorded or checked as required by the testing led changeover process (paragraph 46). It would have been impossible to use the design drawings needed for this process as there were no design drawings showing the uncontrolled wires.
- 142 The functional tester stated that he did not record the uncontrolled wires because he expected them to be removed, along with all the distinctive coloured wiring associated with the test desk, before the railway was returned to operational use. He stated that this had been his experience when adding functions to a test desk on a different project where the test desk had been removed before the railway returned to operational use. However, he stated that he did not know when the test desk would be removed from Waterloo relay room and was not sure when 1524 points would return to operation as he did not know whether they were inside or outside the blockade.

- 143 In order to make the test desk operate correctly, and to leave the railway in a safe condition, the functional tester could have used any of the three following options given in the signalling works testing standard:
- a) If a solution was required only during his shift, the functional tester could have used test straps¹⁸ to create the ‘uncontrolled’ wiring. These test straps should have been recorded on the strap register which is a record of wires available for use by testers. The wiring would then have been controlled because all wires on a strap register should be removed, and the strap register annotated accordingly, before the railway is returned to operational use. The functional tester stated that he did not use test straps because he wanted to implement a solution which remained effective after the end of his shift.
 - b) If a solution was required only until the possession was given up at 04:50 hrs on 14 August, the functional tester should have created a test log describing the test desk problem to the TIC. The TIC would have forwarded this to the appropriate signalling designers who would have designed and checked a modification. If a further modification (eg removal of wiring) was needed before the railway could be returned to operational use, this should have been shown on a second modification sheet.
 - c) If a solution was required beyond the end of the possession, the functional tester should again have created a test log for forwarding by the TIC to appropriate signalling designers. These designers would have designed and checked a modification which would have been safe to leave in place on the operational railway.
- 144 Correct implementation of any of these options would have provided the necessary controls to prevent inappropriate wiring remaining when the railway was restored to normal operation.

Competence

145 The actions of the functional tester were inconsistent with the competence expected of testers.

- 146 There is no evidence of undue pressure influencing the functional tester’s decision to proceed with the solution he had identified and no evidence of it affecting his other actions on 13 August. The functional tester stated that he felt under pressure to resolve the issue so that the principles tester could complete his route testing. He also stated that this did not affect his action except possibly in respect of labelling the wires. Both OSL management and testers who worked at Waterloo reported that individual testers were regularly asked for progress reports by the WCA project management. This was unusual as testers normally report to the TIC who would in turn update project management staff. It is possible that this made the testers more aware than usual of time pressures. However the functional tester stated that, although he was busy, he did not feel under unusual pressure on the weekend of 12 and 13 August.
- 147 Although they cannot be completely ruled out, the RAIB has no evidence that fatigue or other personal factors affected the functional tester’s actions when the uncontrolled wiring was added.

¹⁸ A uniquely identifiable wire, terminated on each end, which can be used by testers to connect terminals together. Testers generally carry a registered pack of straps, which should be fully checked and counted when they are signed onto and off the test strap register.

148 A certificate of competency completed by OSL in March 2017 shows that it considered the functional tester to be competent for the functional testing tasks he was charged with undertaking at Waterloo. Despite this, he adopted none of the processes that were available for safely correcting operation of the test desk (paragraph 143) but instead took the following actions that were beyond the limits of his authority as a functional tester:

- carrying out re-design of the wiring (for which the functional tester did not hold the relevant IRSE licence or authority to work); and
- undertaking design and testing on the same element of work (contrary to the signalling works testing handbook which requires that '*staff who have participated by direct preparation [...] of that particular design [...] shall not assume testing responsibilities*').

149 It is also likely that the functional tester acted as an installer, which requires a certificate of competency that the functional tester did not hold. Undertaking installation and testing on the same element of work is contrary to the signalling works testing handbook which requires that '*staff who have participated [...] directly in...] installation, shall not assume testing responsibilities*'.

150 The RAIB also observes that the solution applied to 1514 points was applied at 1524 points without adequate consideration of the differing circumstances which applied at these locations (paragraph 135).

151 Witness evidence showed that the functional tester:

- had a poor understanding of how testing processes interacted with design and installation processes;
- did not fully consider the potential consequences of adding the uncontrolled wiring (paragraphs 134 and 142);
- was keen to find a solution that would last beyond his shift (paragraph 143a); and
- did not fully understand the reason for only using registered test straps (paragraph 143a).

Securing of points

152 Electrical disconnection, scotches and padlocked clips had not been used to secure 1524 points in a safe position as required by the test plan.

153 The CRE prepared a 'Splitting of Design Methodology' document in May 2017 which was signed as accepted or authorised by six senior members of project staff from WCA and Network Rail. This document was intended to help the testers by identifying the activities which could only be undertaken when the blockade was extended by possessions. This document identified a list of points to be secured because they were both:

- in trackwork which was to be operational during all or part of the 24 day blockade; and
- did not require to be moved during this period.

- 154 The list of points included in the Splitting of Design Methodology document included, among others, 1524A, 1524B and 1524C points. Securing of these points would have avoided them moving to an unsafe position, either due to a route setting error or to a wiring problem in the complex circuits being modified in the Waterloo area.
- 155 The requirement to secure points including the three 1524 point ends was included in a risk workshop on 11 July 2017. The associated action was initially allocated to the TIC, but the risk register which was published later showed the owner as 'project team' with the TIC to supply the padlocks. There was then no individual named in the risk register as responsible for implementing the securing of the points.
- 156 The TIC prepared the signalling test plan which detailed the testing process for the blockade. The final version of the test plan, accepted by Network Rail on 3 August 2017, took account of the design splitting methodology document by including a list of points to be secured and by attaching the document as an appendix. The list of point ends to be secured for the 24 day blockade again included, among others, 1524A, 1524B and 1524C.
- 157 Testers in charge are responsible for the implementation of test plans and should check that all testers involved in the work are briefed and fully conversant with their duties. However, the TIC stated that he had assumed, when implementing the test plan for the blockade, that possession management staff would secure the points, so he:
- did not instruct anyone to secure any points; and
 - did not check, or instruct anyone else to check, that any points were secured.
- 158 The possession management staff had only been asked to secure points required by the railway rule book¹⁹ to protect the blockade. These requirements do not include points on the blockade flank, such as 1524 points.
- 159 Separately from the CRE's requirement to secure 1524 points, an email from a project manager requested that points which would be under the engineering train should be secured to protect against inadvertent movement while the track circuits, which would normally prevent them moving, were disconnected. This led to 1524C points being secured, but not 1524A and 1524B point ends as they were not under the train.

Other factors

- 160 The RAIB has considered the extent to which wider project management issues contributed to the accident. In particular, the RAIB assessed the extent to which each of the following issues played a role in the accident:
- previous incidents which occurred during the capacity improvement project at London Waterloo;
 - late changes to possession size arrangements (paragraph 61);
 - the amount of work that was being undertaken in the possession; and
 - the pressure on staff to complete work activities within a tight programme.

¹⁹ GE/RT8000/T3 issue 8, Possession of a running line for engineering work.

161 The RAIB observes that each of the above had the potential to introduce additional risk. However, it has found no evidence that any of these issues were linked to the causes of the accident on 15 August 2017.

Identification of underlying factors

162 OSL, MML and Network Rail competence management processes had not addressed the full requirements of the roles undertaken by the staff responsible for the design, commissioning and testing of the signalling works.

163 Competence of staff comprises knowledge, skills and attitudes. It encompasses both the technical and non-technical skills needed to undertake a job role. Non-technical skills are the social, cognitive and personal skills that can influence the way that individuals undertake technical tasks²⁰. When undertaking complex tasks in a safety critical environment, it is vital that individuals have a good understanding of the equipment they are working with and the principles that underpin the mandated procedures. This understanding is essential for them to properly appreciate the consequences of the actions they take. The actions of the functional tester (paragraphs 131 to 144) and the actions of both the CRE and project engineer (paragraphs 103 to 129) indicate that appropriate non-technical skills were not applied.

OSL management

164 Before joining OSL in 2013, the functional tester's functional and verification testing categories had been withdrawn from his certificate of competency (paragraph 16). This was because of an incident in which he had signed paperwork stating that testing of points was complete based on an assurance by another person that it would be completed at an appropriate time. OSL was not involved in this incident but provided the functional tester with the mentoring which allowed the categories to be reinstated in 2014.

165 OSL created a development action plan, when it employed the functional tester, to address his revoked certification. This plan included a stated need to address his 'soft skills' (non-technical skills). However, the methodology in the development plan referred only to technical skills.

166 The development action plan was accepted (in 2012) by the then Network Rail testing and commissioning project engineering manager, who was a senior testing manager at Network Rail. The current holder of this role has stated that he would have expected 'soft skills' to be addressed by mentorship. However there was no formally recognised method to address this element of the development action plan.

²⁰ The RSSB defines non-technical skills as the 'social, cognitive and personal skills that can enhance the way you or your staff carry out technical skills, tasks and procedures'.

- 167 The mentorship comments added periodically to the development action plan by the functional tester's mentors were positive but only refer to technical skills. There is no evidence that implementation of the plan included actions addressing his non-technical skills. However OSL stated that its managers' knowledge of the functional tester's behaviour before the accident led them to believe that he had been a cautious employee since regaining his functional tester certificate of competency.
- 168 OSL had a competence management process in place for all its staff, which covered specific technical skills and knowledge but did not formally cover the depth of their understanding and the non-technical skills needed to ensure safety. These attributes include recognising when it is inappropriate to carry out a task and when input is required from other people.
- 169 In 2015 OSL introduced behaviour awareness training for new starters and some of its staff. OSL stated that this aimed to give staff a better understanding of why accidents happen, an understanding of behaviours and culture, and the confidence to speak up for safety. It is possible that such training would have led to the functional tester acting differently at Waterloo. However, he had started working for OSL before it began giving the training to new starters and there is no record of whether he received this training.

MML and Network Rail management

- 170 Management processes applied by MML and Network Rail did not result in the CRE and the project engineer applying some of the required processes applicable to the test desk and interlocking. Specifically:
- the test desk design was not updated to maintain compatibility with changes to the interlocking design (paragraph 105);
 - the spur wires were not shown on the interlocking drawings (paragraph 116); and
 - no risk assessment was undertaken for the spur wires (temporary works) which remained attached to the interlocking while this was in operational use (paragraph 126).
- 171 Although the CRE was not directly employed by MML, he was covered by its competence management system. He had a 20 year history of working intermittently with the same MML team, and on this occasion had done so since 2016.
- 172 The project engineer was not directly employed by Network Rail, but was covered by its competence management system. He had worked with the same team since 2014.
- 173 Network Rail requires that people appointed as contractors responsible engineers and project engineers have appropriate skills and previous experience (NR/L2/INI/02009, paragraph 39). For the work at Waterloo, both MML and Network Rail were required to review, and accept as satisfactory, the CRE's skills and qualifications. Network Rail was required to do this for the project engineer. Network Rail requirements for both posts included the need for an authority to work, issued by their employer and showing them as competent for their roles. Network Rail did not require particular IRSE licences or associated certificates of competency for these roles. However, both post holders at the time of the accident held licences relating to signalling design work.

- 174 MML issued the CRE's authority to work based on a description of his experience, a record of technical competence assessments and a list of qualifications. This documentation describes technical skills and experience but includes only a small element of non-technical skills.
- 175 Network Rail issued the project engineer with an authority to work in this role which summarises the assessment justifying his competence. The assessment consists of a competency assessment and interview using criteria given in NR/L2/INI/02009. These criteria refer only to technical skills. Network Rail also referred to a description of his experience which described his technical input to projects (paragraph 19). Neither the authority to work, nor this description, explicitly refer to non-technical skills. Although his previous roles would have included considering the individual technical issues expected to be encountered at Waterloo, these documents do not contain evidence showing that he had the non-technical skills needed to manage these technical issues in a large and complex environment such as the capacity enhancement project. The necessary management skills include ensuring robust application of safety related procedures.

Observations

Maintenance drawings

176 The relay room maintenance drawings did not provide a definitive description of the equipment in the relay room.

- 177 Module A8 of the signalling design handbook required that maintenance copies of the signalling design were available for maintenance and fault finding technicians. Copies of these documents must be available close to the circuits they depict (in the relay room for example). Any superseded sheets should be removed or clearly marked.
- 178 The RAIB found two versions of the maintenance copies relevant to 1524 points in the relay room immediately after the accident. One version showed the wiring arrangements for 1524 points detection before the circuits were modified in June 2017. The other version showed the arrangements after this time.
- 179 MML had provided OSL with updated maintenance copies to be placed in the relay room when it completed testing of the June 2017 modifications. The testers placed these in the relay room when the modifications were complete, for Network Rail maintainers to file, as had been agreed with the maintainers. The superseded copies should have been removed or clearly marked to avoid confusion. It is not known why this did not happen.
- 180 Although not a cause of the Waterloo accident (paragraph 133), use of incorrect wiring diagrams can result in incorrect installation or modification of equipment. The incorrect diagram also increases the likelihood of this not being detected during subsequent testing.

Interlocking detailed design documents

181 The absence of the spur wires on the interlocking detailed design documents would have adversely affected the integrity of the final wire count.

182 A wire count is mandated by the works testing handbook as it is one of the essential safety checks needed before modified signalling systems are returned to operational use. Wire counting involves checking that the number of wires attached to every terminal affected by the modification matches the number of wires shown on the design documents. Any anomalies must be resolved before equipment is returned to operational use. Enabling a reliable wire count is one of the reasons for the signalling design handbook requirement that 'temporary works' are shown on detailed design documents.

183 Wire counting is facilitated by analysis sheets (part of the detailed design documents). These list each terminal and the number of wires attached to it. Each terminal should only be shown once on analysis sheets. The fuse terminals used for the spur wires formed part of the interlocking and the analysis for these terminals was included in the interlocking detailed design documents (and so correctly not shown on the test desk analysis sheets). Omission of the spur wires from the interlocking detailed design documents (paragraph 116) meant that these wires were omitted from the analysis sheets needed for wire counting the fuse terminals.

184 A wire count was required in the interlocking during the final night of the blockade at Waterloo. The MML interlocking drawings included 664 fuse terminals without showing the test desk wiring attached to these terminals. The test desk wiring was not included in the analysis sheets (paragraph 121). The mismatch between the documents and the wires actually attached to the terminals would have complicated the wire counting process by requiring the investigation of a large quantity of discrepancies. This would have increased the risk of errors, potentially resulting in incorrect (and possibly unsafe) wiring being left in an operational installation.

Parallels with the Clapham Junction accident

185 Some of the lessons from the 1988 Clapham Junction accident are fading from the railway industry's collective memory.

186 Events at Waterloo and the RAIB's investigation of the serious irregularity at Cardiff East Junction (paragraph 189) suggest that some in the railway industry are forgetting the lessons learnt from the 1988 Clapham Junction accident in which 35 people died. The major changes to signalling design, installation and testing processes triggered by the Clapham accident remain today, but the RAIB is concerned that the need for rigorous application is being forgotten as people with personal knowledge of this tragedy retire or move away from front line jobs. This deep-seated, tacit knowledge is part of the corporate memory vital to achieve safety. Loss of this type of knowledge as previous generations leave the industry is a risk which must be addressed by organisations committed to achieving high levels of safety.

- 187 The accident on 12 December 1988 involved three trains colliding just south of Clapham Junction, in London. It happened when a train driver received a proceed aspect at a signal which should have been at danger, and collided with the train in front which should have been protected by the signal. The incorrect proceed aspect was shown because inadequate working practices during a re-signalling project had resulted in a loose, uninsulated redundant wire remaining close to, and eventually coming into contact with, other circuitry.
- 188 A public inquiry chaired by Anthony Hidden QC investigated the Clapham Junction accident. The report of the investigation, known as the Hidden²¹ report, made recommendations which reformed the way railway signalling was designed, installed and tested in the UK. The similarities between factors found at Clapham and the accident at Waterloo are summarised in table 1. The ways in which the Hidden recommendations should have prevented the Waterloo accident are shown in table 2.
- 189 Fading collective memory of Clapham Junction was also apparent in the RAIB's investigation into a serious irregularity at Cardiff East Junction on 29 December 2016 ([RAIB Report 15/2017](#)²²). This involved a set of redundant points left unsecured in the railway when it was returned to service after an engineering possession. They were not secured because the team which was responsible for this activity did not identify all of the redundant points that required securing. The similarities between factors found at Clapham Junction and the incident at Cardiff are also included in table 1 and the ways in which the Hidden recommendations should have prevented the Cardiff incident are included in table 2.
- 190 The accident at Waterloo and the Cardiff East Junction incident resulted from people taking actions which were inconsistent with the processes in which they had been assessed as competent. Had these processes been followed, the events would have been prevented. The RAIB found no evidence that the staff and organisations involved at Waterloo and Cardiff lacked a commitment to safety. In this respect, the RAIB's findings at Waterloo and Cardiff have much in common with this extract from the Hidden report chapter 17 'Where things went wrong – The Lessons to be learned':

The vital importance of this concept of absolute safety was acknowledged time and again in the evidence which the Court heard. This was perfectly understandable because it is so self-evident. The problem with such expressions of concern for safety was that the remainder of the evidence demonstrated beyond dispute two things:

(i) there was total sincerity on the part of all who spoke of safety in this way; but nevertheless

(ii) there was failure to carry those beliefs through from thought into deed...

The concern for safety was permitted to co-exist with working practices which... were positively dangerous.

²¹ http://www.railwaysarchive.co.uk/documents/DoT_Hidden001.pdf.

²² RAIB reports are available at www.gov.uk/raib.

Clapham Junction	Waterloo	Cardiff
Working practices were permitted to slip to unacceptable and dangerous standards.	Documented processes for controlling design modifications and testing were not used when uncontrolled wiring was installed (paragraphs 131 to 144).	The project team had developed a work group culture that led to insular thinking about methods of work and operational risk.
Full documentation was not available.	Out of date maintenance drawings in the relay room were not identified as superseded (paragraph 176).	Individual signalling stage scheme plans had not been produced for the sub-stages of the stage 5 works. If such plans had been available, it would have been clear which points required securing. There was no single project document with a complete list of all the points that required securing.
The quality of testing did not meet standards set by BR.	The testing led changeover process was not followed (paragraphs 131 to 144). Test logs were not raised, during previous stages of the project, for test desk wiring omitted from the interlocking design drawings (paragraph 124) Information for a reliable wire count was not available as the spur wires were not recorded on the interlocking detailed design documents (not a cause of the accident, paragraph 181).	The tester in charge signed a form confirming that he had received confirmation that all out of use points were safely secured and padlocked. The points were not listed individually, and the tester in charge signed the form on the basis that the senior construction manager had confirmed that the points had been secured. This was non-compliant with the standards governing the commissioning of signalling equipment because the senior construction manager was involved in carrying out the work.
There was no effective control over the Design Office to ensure that the workforce were supplied with drawings which accurately reflected the work to be done.	The effect of the interlocking design changes on the test desk was not apparent because the spur wires (temporary works) were not recorded on the interlocking detailed design documents (paragraphs 105 to 125).	There was no single project document with a complete list of all the points that required securing. Individual signalling stage scheme plans had not been produced for the sub-stages of the stage 5 works.
Failure to communicate effectively both up and down the lines of management.	OSL testers were aware, shortly before commissioning, that the test desk might not function correctly, but the necessary management actions were not communicated to relevant staff (paragraphs 113 to 115).	The all-team briefing contained a considerable amount of information, much of which was superfluous to many of the attendees. People who attended the briefing said that they had difficulty filtering out the information that was relevant to them as there was so much detail, even where they were familiar with the whole scope of works.
	No one was allocated the task of securing points outside the blockade although this task was listed in the test plan and discussed at a risk workshop (paragraph 152).	The designated project engineer (a senior member of staff) had removed the responsibility for checking the securing of points from the tester in charge, as he believed the tester in charge had too much else to do. However, the designated project engineer did not allocate the responsibility to anyone else.

Table 1: Comparison of shortcomings at Clapham Junction, Cardiff and Waterloo

Hidden report	Applicability to Waterloo	Applicability to Cardiff
<p>Hidden recommendation 3</p> <p>BR shall enforce tighter control on Design Office procedures for the production, issue and amendment of documents to ensure that all working drawings are complete and are an accurate representation of the system to be worked on and of the work to be done to that system.</p> <p><i>[The implementation of this recommendation resulted in the development and publication of the signalling design handbook.]</i></p>	<p>Compliance with the signalling design handbook would have resulted in the test desk spur wires being shown on the interlocking detailed design documents. It is probable that this would have led to recognition that the test desk needed updating (paragraphs 105 to 125).</p>	<p>Compliance with the signalling design handbook would have resulted in a stage scheme plan being produced. This should have shown all of the redundant points which should have been secured.</p>
<p>Hidden recommendation 4</p> <p>BR shall urgently ensure that an independent wire count is carried out as a matter of practice during testing. It shall be the responsibility of the person in overall charge of testing to ensure and to document that an independent wire count has been done. This function may be delegated to works staff who did not do the work.</p> <p><i>[An expectation that workforce includes management is apparent in paragraph 17.11 of the Hidden report: 'the errors go much higher and wider in the organisation than merely to remain at the hands of those working that day'.]</i></p>	<p>The drawings for the modified interlocking at Waterloo did not show the test desk spur wires and so did not show the information needed to implement this recommendation reliably (paragraph 181). No wire count was undertaken (or required) before the possession was handed back before the accident so this is not a cause of the accident.</p>	
<p>Hidden recommendation 9</p> <p>BR shall introduce a national testing instruction with all speed. Such instruction shall be accompanied by a full explanation to the workforce including workshops or seminars as necessary. Implementation must be monitored and audited.</p> <p><i>[The implementation of this recommendation resulted in the signalling works testing standard.]</i></p>	<p>Compliance with the signalling works testing standard would have provided the controls needed to prevent installation of the uncontrolled wiring (paragraph 143).</p> <p>Monitoring and auditing of the workforce should have been sufficient to recognise that attitudes had changed by 2017 to the extent that some signalling staff no longer saw the need for strict compliance with process, or the reasons for doing so. Explanations to the workforce limited to technical issues would not be expected to achieve this (paragraphs 168 and 174).</p>	<p>The tester in charge signed a test certificate (the master test certificate) to confirm that all out of use points were safely secured and padlocked. The tester in charge had received confirmation that the points were secured from the senior construction manager. However, this had not been independently verified as required by the signalling works testing standard.</p> <p><i>This finding at Cardiff East supports the conclusion in the adjacent column concerning monitoring and auditing.</i></p>

Hidden report	Applicability to Waterloo	Applicability to Cardiff
<p>Hidden recommendations 18 and 19</p> <p>BR shall ensure that overtime is monitored so that no individual is working excessive levels of overtime. BR, in conjunction with the Unions, shall introduce the concept of scheduled hours within the Signals and Telecommunications Department in order to make better provision for work which has to be carried out at weekends.</p>		<p>The project team had signed up to a fatigue management agreement but it was not reliably implemented. The investigation found evidence of a widespread disregard of the agreed rules on hours of work and a culture of working long hours.</p>

Table 2: How the Hidden recommendations should have prevented the accident at Waterloo and the Cardiff incident

Summary of conclusions

Immediate cause

191 The train was signalled to run over a set of points which were in the incorrect position (paragraph 83).

Causal factors

192 The causal factors were:

- a) Uncontrolled wiring was added to points detection circuits, such that the position of 1524 points was incorrectly detected (paragraph 87).
- b) The uncontrolled wiring was added during testing when the test desk was found to no longer simulate the detection of 1524 points correctly, a consequence of an incomplete design process (paragraph 102). In particular:
 - the test desk design did not allow for later changes to the interlocking design (paragraph 105, **Recommendations 1 and 3, Learning point 1**);
 - the temporary spur wires for the test desk were not shown on the interlocking drawings, an omission which probably led to a lack of recognition that the test desk design needed updating (paragraph 116, **Recommendations 1 and 3, Learning point 1**); and
 - no risk assessment was prepared for the temporary spur wiring (paragraph 126, **Recommendations 1 and 3, Learning point 1**).
- c) The actions taken to make the test desk simulate the operation of 1524 points correctly were not in line with signalling works testing standard, and uncontrolled wiring was not removed before train services restarted across 1524 points (paragraph 130, **Recommendations 1 and 2, Learning point 1**).
- d) The actions of the functional tester were inconsistent with the competence expected of testers (paragraph 145, **Recommendations 1 and 2, Learning point 1**).
- e) 1524 points had not been secured in the normal position by disconnecting the points electrically and fitting scotches and padlocked clips, as had been required by the test plan (paragraph 152, **Recommendations 1 and 2, Learning points 2 and 3**).

Underlying factor

193 An underlying factor was that OSL, MML and Network Rail competence management processes had not addressed the full requirements of the roles undertaken by the staff responsible for the design, commissioning and testing of the signalling works (paragraph 162, **Recommendations 1, 2 and 3, Learning point 1**).

Observations

194 The RAIB made the following observations:

- a) the relay room maintenance drawings did not provide a definitive description of the equipment in the relay room (paragraph 176, **Recommendations 1 and 2, Learning point 4**); and
- b) the absence of the spur wires on the interlocking detailed design documents would have adversely affected the integrity of the final wire count (paragraph 181, **Recommendations 1 and 3, Learning point 1**).

Parallels with the Clapham Junction accident

195 Parallels with the 1988 Clapham Junction accident show that some of the lessons learnt from this accident are fading from the railway industry's collective memory (paragraph 185).

Actions reported as already taken

- 196 RSSB has produced a number of learning presentations and documents relating to the relevance of corporate memory to railway safety. This includes articles in Rail Safety Review, a publication available to RSSB members. The Learning from Operational Experience Annual Report (produced by RSSB until 2017) also captured information learnt in the year, often tying it back to lessons learnt in the past. Network Rail and RSSB also contributed to 'Learning from History'²³, a document dealing with corporate memory and published by Rail magazine, which referred to the lessons from the Clapham Junction accident.
- 197 OSL has reported that it has reinforced its behaviour awareness training and is delivering it on a yearly basis to all staff. It has also appointed behavioural partners who support the behavioural culture programme, with the aim of being approachable and engaged with their core team.
- 198 OSL has also reported that it has briefed all of its design staff on the importance of defining how works are managed when undertaking a design package with another contractor. The briefing note refers to the requirement to ensure that interfaces and scope are clearly defined before work starts. Staff are encouraged to use the company's work safe policy if they have a safety concern. This gives them the right to speak up and if necessary refuse to work.

²³ <https://www.railmagazine.com/special-reports/network-rail>.

Recommendations and learning points

Recommendations

199 The following recommendations are made²⁴:

- 1 *The intent of this recommendation is to ensure that the competence of signalling staff includes the attitudes and depth of understanding that is needed to properly appreciate the importance of applying all the relevant design, installation and testing processes. It is expected that effective implementation by Network Rail will necessitate input from the Institution of Railway Signal Engineers, signalling contractors and other infrastructure managers.*

Network Rail should take steps to reinforce the attitudes and depth of understanding needed for signal designers, installers and testers to safely apply their technical skills and knowledge. These steps should include:

- the education of existing staff and their managers, and future recruits, to promote a better understanding of industry processes, and an improved understanding of how the lessons learnt from previous accidents have shaped today's good practice;
- the enhancement of processes for the assessment, development and ongoing monitoring of the non-technical skills of signal designers, installers and testers; and
- measures to monitor and encourage compliance with process, and safe behaviours on projects.

²⁴ Those identified in the recommendations have a general and ongoing obligation to comply with health and safety legislation, and need to take these recommendations into account in ensuring the safety of their employees and others.

Additionally, for the purposes of regulation 12(1) of the Railways (Accident Investigation and Reporting) Regulations 2005, these recommendations are addressed to the Office of Rail and Road (ORR) to enable it to carry out its duties under regulation 12(2) to:

- (a) ensure that recommendations are duly considered and where appropriate acted upon; and
- (b) report back to RAIB details of any implementation measures, or the reasons why no implementation measures are being taken.

Copies of both the regulations and the accompanying guidance notes (paragraphs 200 to 203) can be found on RAIB's website www.gov.uk/raib.

- 2 *The intent of this recommendation is for OSL to implement actions already started (paragraphs 197 and 198) in respect of non-technical skills relevant to its staff in advance of any relevant actions triggered by implementation of Recommendation 1.*

OSL Rail Ltd should enhance its existing processes for the assessment, development and ongoing monitoring of those staff who undertake signalling works so as to ensure that they have the depth of understanding, attitudes and non-technical skills that are needed to deliver work safely. Areas of enhancement should include the skills needed for effective communication and safe decision making in complex project environments.

This recommendation may apply to other signalling design, installation and testing organisations.

- 3 *The intent of this recommendation is for Mott MacDonald Ltd to take action in respect of non-technical skills relevant to its staff in advance of any relevant actions triggered by implementation of Recommendation 1. It differs from Recommendation 2 by omitting explicit reference to communication because the RAIB Waterloo investigation did not link MML to communication issues. However, the recommendation covers all aspects of non-technical skills and implementation is expected to include consideration of communication issues.*

Mott MacDonald Ltd should enhance its existing processes for the assessment, development and ongoing monitoring of those staff who undertake signalling works so as to ensure that they have the depth of understanding, attitudes and non-technical skills needed to deliver work safely. Areas of enhancement should include the skills needed for safe decision making in complex project environments.

Learning points

200 The RAIB has identified the following key learning points²⁵:

- 1 Signalling design, installation and testing staff at all levels must understand that modern signalling design, installation and testing processes exist to prevent accidents such as that at Clapham Junction in 1988. The importance of these established processes, and the potential for unsafe events to occur when they are not followed, is demonstrated by events at Waterloo and Cardiff ([RAIB report 15/2017](#)). Substituting alternative informal processes has the potential to degrade the safety integrity of the signalling system.
- 2 The Waterloo project team specified the securing of points to reduce risks associated with working on this particularly complex infrastructure. This was beyond normal requirements and the RAIB regards it as a good example of assessing site specific risks and identifying practical mitigation.
- 3 The intended securing of points at Waterloo was probably omitted because responsibility was not allocated effectively. Staff responsible for planning the use of non-standard precautions are reminded that to both implement and verify these precautions, there is a need for staff to be allocated to these duties and processes put in place for them to follow.
- 4 Signalling projects are reminded of the importance of providing correct and up to date drawings when returning the railway to operational use. These should be provided at locations (eg relay rooms) where staff expect to find them, with any superseded versions being clearly identified as superseded.

²⁵ 'Learning points' are intended to disseminate safety learning that is not covered by a recommendation. They are included in a report when the RAIB wishes to reinforce the importance of compliance with existing safety arrangements (where the RAIB has not identified management issues that justify a recommendation) and the consequences of failing to do so. They also record good practice and actions already taken by industry bodies that may have a wider application.

Appendices

Appendix A - Glossary of abbreviations and acronyms

CRE	Contractor's responsible engineer
IRSE	Institution of Railway Signal Engineers
MML	Mott MacDonald Limited
OSL	OSL Rail Limited
RSSB	A not-for-profit company owned and funded by major stakeholders in the railway industry, and which provides support and facilitation for a wide range of cross-industry activities. The company is registered as 'Rail Safety and Standards Board', but trades as 'RSSB'.
TIC	Tester in charge
WCA	Wessex Capacity Alliance

Appendix B - Investigation details

The RAIB used the following sources of evidence in this investigation:

- CCTV and on-train data recorder from the train involved in the accident;
- information from signalling data logger downloads;
- witness statements;
- project documentation;
- Network Rail standards;
- RSSB documents;
- IRSE licensing requirements;
- procedures and systems in place at contractors;
- the Clapham Junction railway accident report by Sir Anthony Hidden QC; and
- a review of previous RAIB investigations that had relevance to this accident.

Appendix C - 1524 points wiring at the time of derailment

This diagram corresponds with the simplified arrangement shown on figure 18.

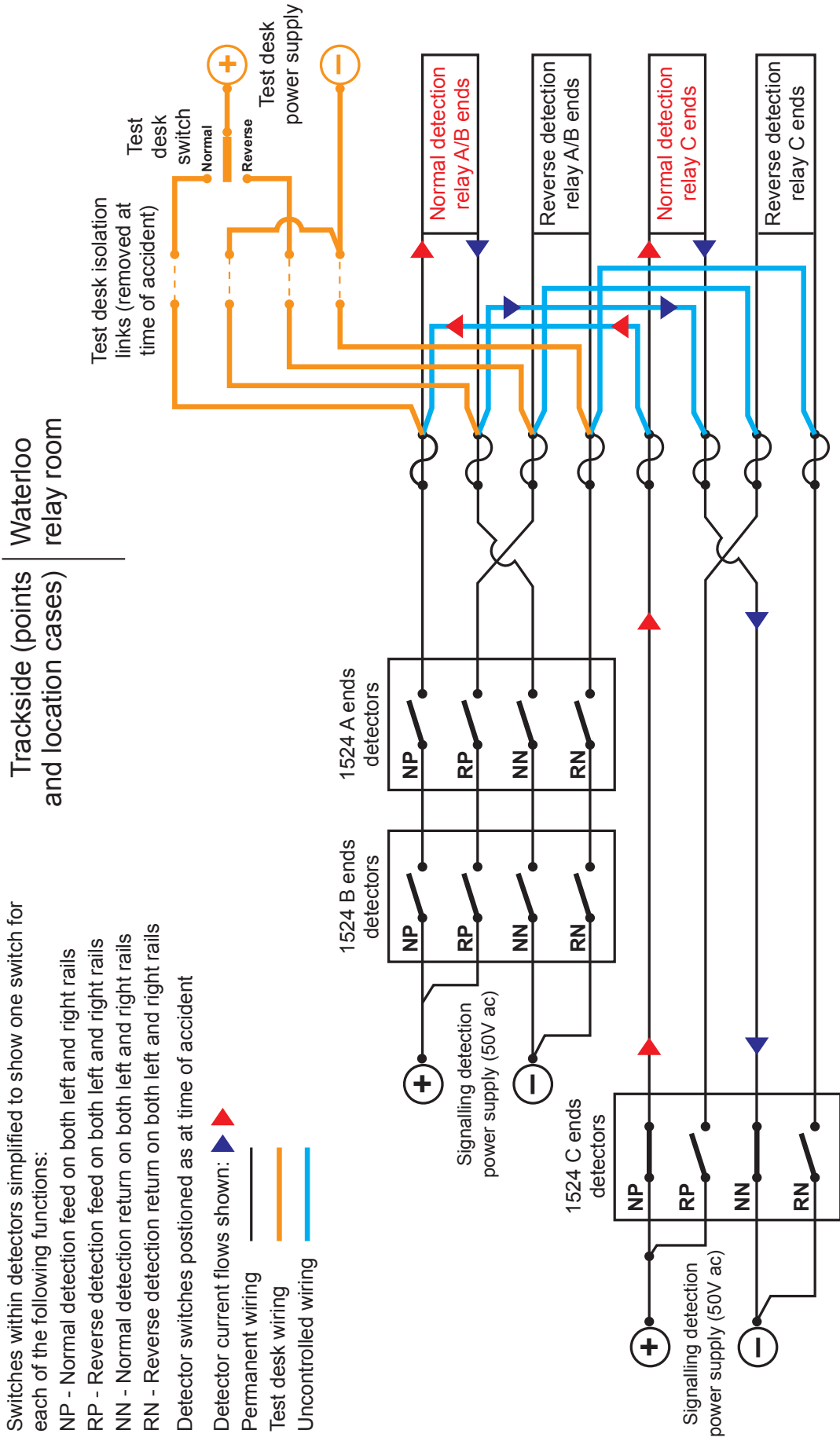

This page is intentionally left blank

This report is published by the Rail Accident Investigation Branch,
Department for Transport.

© Crown copyright 2018

Any enquiries about this publication should be sent to:

RAIB	Email: enquiries@raib.gov.uk
The Wharf	Telephone: 01332 253300
Stores Road	Website: www.gov.uk/raib
Derby UK	
DE21 4BA	