

The Rail Vehicle Accessibility (Non-Interoperable Rail System) (Glasgow Subway) Exemption Order 2023

The Secretary of State makes this Order in exercise of the powers conferred by section 183(1), (2), (4)(a), (5) and (7) and 207(1) and (4) of the Equality Act 2010 of the Equality Act 2010(a).

In accordance with section 183(4) of the Equality Act 2010 the Secretary of State has consulted with the Disabled Persons Transport Advisory Committee(b) and such other persons as the Secretary of State considers appropriate.

Citation and Commencement

1. This Order may be cited as the Rail Vehicle Accessibility (Non-Interoperable Rail System) (Glasgow Subway) Exemption Order 2023 and comes into force on 14th July 2023.

Interpretation

2. In this Order—

“exempt vehicle” means a rail vehicle of the type known as Stadler AG Electric Multiple Units numbered 301-317, with vehicles numbered 301A-317A, 301B-317B, 301C-317C and 301D-317D;

“Glasgow Subway” means the underground railway network operated in Glasgow by the Strathclyde Partnership for Transport;and

“2010 Regulations” means the Rail Vehicle Accessibility (Non-Interoperable Rail Systems) Regulations 2010(c).

Exemption relating to facilities for disabled persons

3. An exempt vehicle is authorised to be used for carriage on the Glasgow Subway, even if it does not conform to, or is used in a manner that does not conform to, the following requirement in Part 1 of Schedule 1 to the 2010 Regulations –

- (a) paragraph 13(3)(priority seats), in relation to the requirement to comply with the specifications either diagram C2, C3 or C4 in Schedule 2 to the 2010 Regulations, provided the vehicle complies with the specifications shown in the diagram 1or 2 set out in the Schedule to this Order.

Signed by authority of the Secretary of State for Transport

13th July 2023

Peter Wilkinson
Managing Director, Passenger Services
Department for Transport

(a) 2010 c. 15; section 183(7) was inserted by the Deregulation Act 2015 (c. 20), Schedule 10, paragraph 29(3).
(b) The Disabled Persons Transport Advisory Committee was established under Section 125 of the Transport Act 1985 (c. 67) and has a statutory duty to provide the Government with advice on the public passenger transport needs of disabled people.
(c) S.I. 2010/432.

SCHEDULE DIAGRAMS

Article 3(a)

(Note - diagrams are not to scale and measurements are given in millimetres)

Diagram 1 (Window Seating Position)

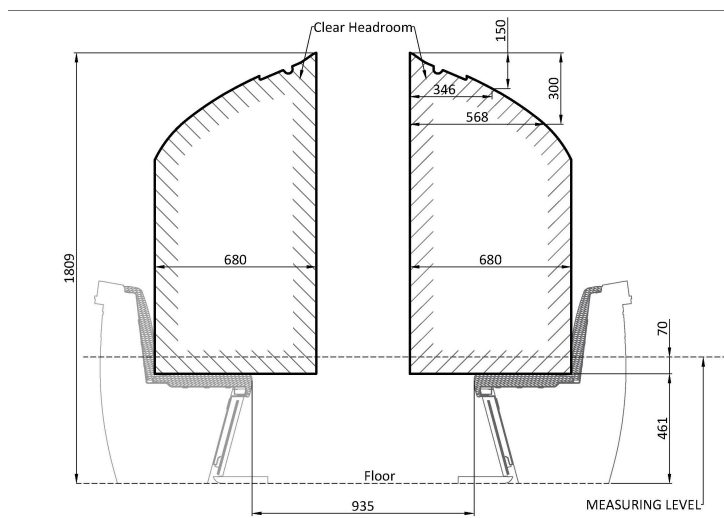

Diagram 2 (Non-Window Seating Position)

