



Date: 21 March 2023

Our Ref: RFI4225

Tel: 0300 1234 500

Email: infogov@homesengland.gov.uk

By Email Only

Information Governance Team
Homes England
Windsor House – 6th Floor
50 Victoria Street
London
SW1H 0TL

Dear [REDACTED]

RE: Request for Information – RFI4225

Thank you for your request for information which was processed in accordance with the Freedom of Information Act 2000 (FOIA).

You requested the following information:

Please can I request your IT Contractor spend for FY 2022 and the agencies in which you have engaged.

Please can you also confirm the current number of IT Contractors you are engaged with.

Please can you also send me your current IT Organisation Chart

Response

We can confirm that we do hold some of the requested information. We will address each of your questions in turn.

Please can I request your IT Contractor spend for FY 2022 and the agencies in which you have engaged.

Please see table below which shows IT Contractor spend for the financial year 2022 to 2023 and the agencies engaged. Please note that the spend is only inclusive up to the date that this request was received (2 February 2023) and not for the full financial year. Please also note that the agency spend listed in the table below is the result of a short-term IT transformation.

	2022/23
AGENCY	£
EVISA SOLUTIONS LTD T/A MALIKSHAW	359,853.16
GATENBY SANDERSON	60,320.00
HARVEY NASH LIMITED	232,344.00
INTERQUEST GROUP UK LIMITED	1,612.80
INVESTIGO LIMITED	163,636.96
METHODS BUSINESS & DIGITAL TECHNOLOGY LTD	147,673.85
PENNA PLC	132,212.00
REED EMPLOYMENT PLC	49,066.00
STCS LTD	357,747.00
	1,504,465.77



Homes
England

Making homes happen

Date: 21 March 2023

Our Ref: RFI4225

Tel: 0300 1234 500

Email: infogov@homesengland.gov.uk

Please can you also confirm the current number of IT Contractors you are engaged with.

We have interpreted "IT Contractors" to mean all contractors working in traditional IT (technical) roles and therefore can confirm that we have 22 contractors.

Please can you also send me your current IT Organisation Chart

We can inform you that we do hold the information that you have requested. Please find enclosed Annex A which contains a copy of Homes England's IT Organisation Chart. However, we rely on Section 40 (2) of the FOIA to withhold some of the information from disclosure.

Section 40 – Personal information

We have redacted information on the grounds that it constitutes third party personal data and therefore engages section 40(2) of the FOIA.

To disclose personal data, such as names, contact details, addresses, email addresses and personal opinions could lead to the identification of third parties and would breach one or more of the data protection principles.

Section 40 is an absolute exemption which means that we do not need to consider the public interest in disclosure. Once it is established that the information is personal data of a third party and release would breach one or more of the data protection principles, then the exemption is engaged.

The full text in the legislation can be found on the following link:

<https://www.legislation.gov.uk/ukpga/2000/36/section/40>

Right to Appeal

If you are not happy with the information that has been provided or the way in which your request has been handled, you may request an internal review. You can request an internal review by writing to Homes England via the details below, quoting the reference number at the top of this letter.

Email: infogov@homesengland.gov.uk

The Information Governance Team
Homes England – 6th Floor
Windsor House
50 Victoria Street
London
SW1H 0TL

Your request for review must be made in writing, explain why you wish to appeal, and be received within 40 working days of the date of this response. Failure to meet this criteria may lead to your request being refused.

Upon receipt, your request for review will be passed to an independent party not involved in your original request. We aim to issue a response within 20 working days.

OFFICIAL



Homes
England

Making homes happen

Date: 21 March 2023

Our Ref: RFI4225

Tel: 0300 1234 500

Email: infogov@homesengland.gov.uk

You may also complain to the Information Commissioner's Office (ICO) however, the Information Commissioner does usually expect the internal review procedure to be exhausted in the first instance.

The Information Commissioner's details can be found via the following link:

<https://ico.org.uk/>

Please note that the contents of your request and this response are also subject to the Freedom of Information Act 2000. Homes England may be required to disclose your request and our response accordingly.

Yours sincerely,

The Information Governance Team
For Homes England

OFFICIAL

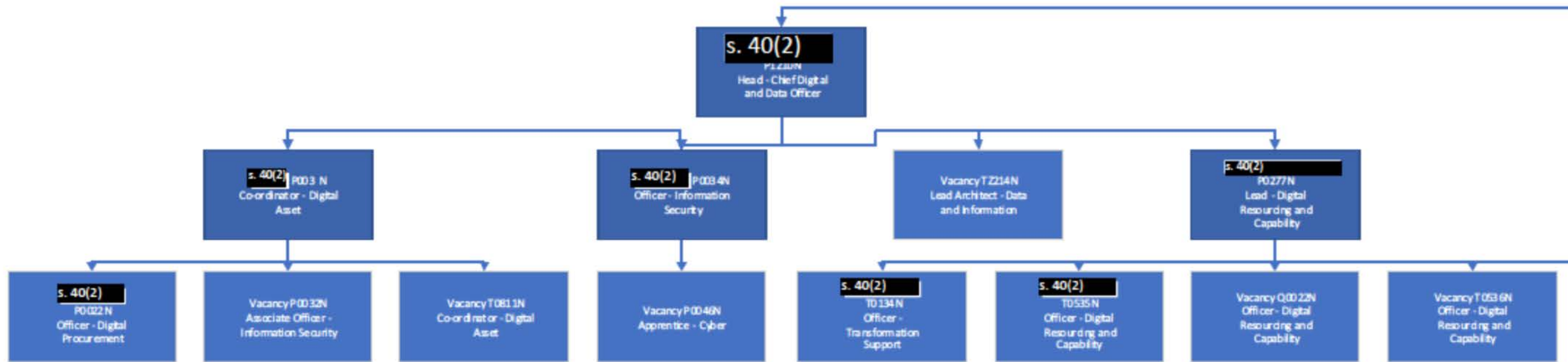

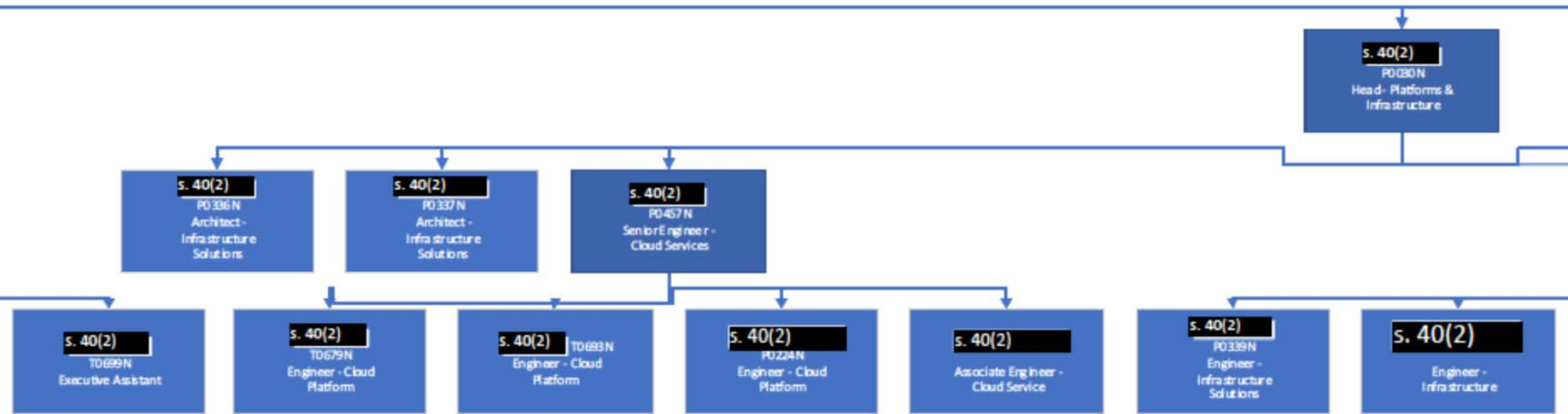

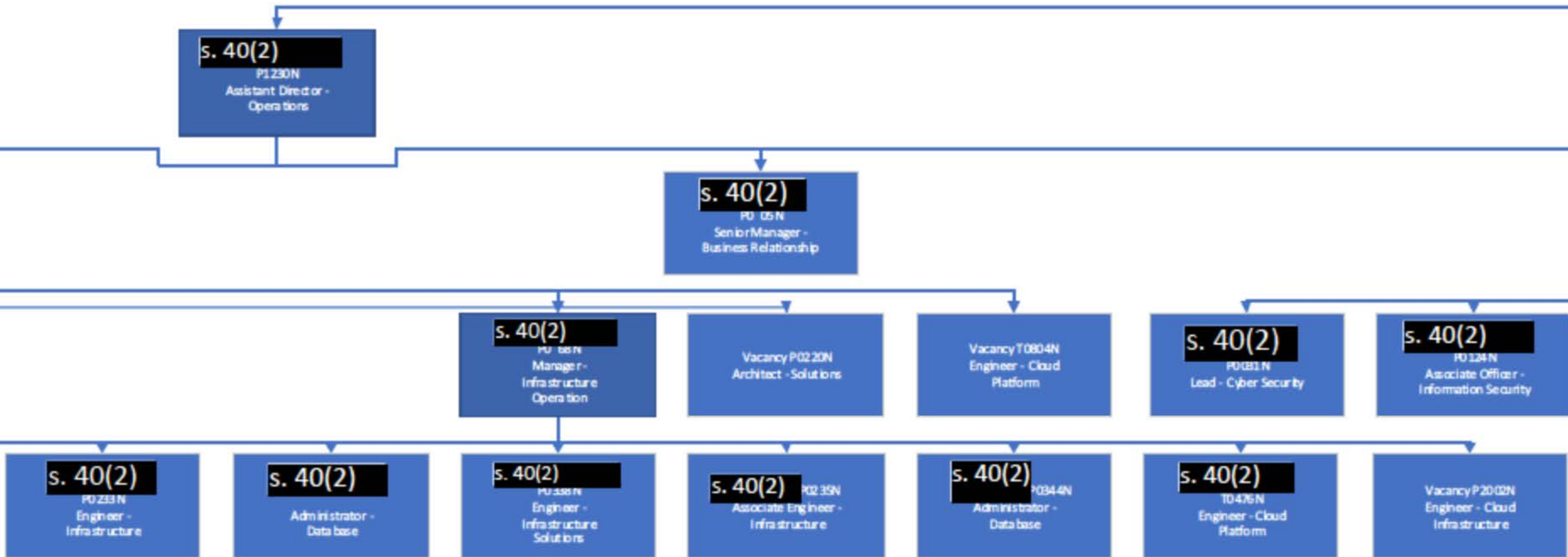

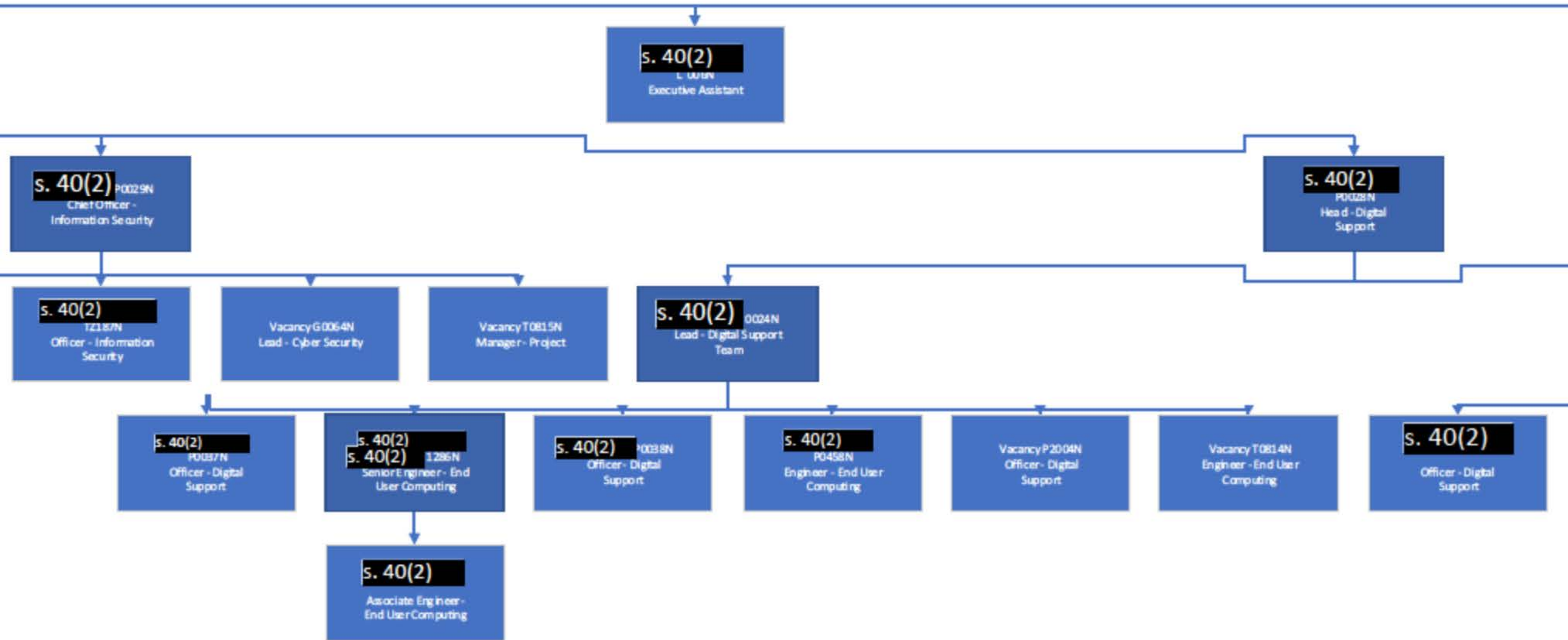

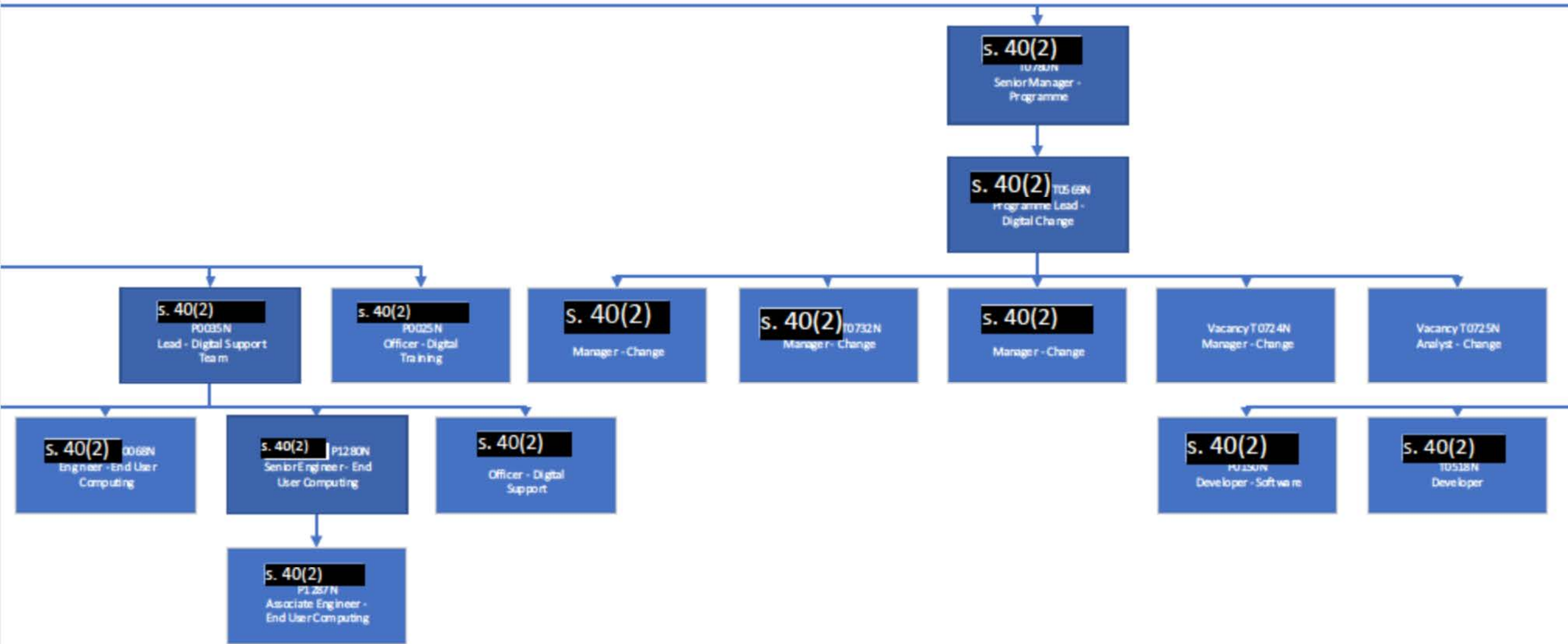

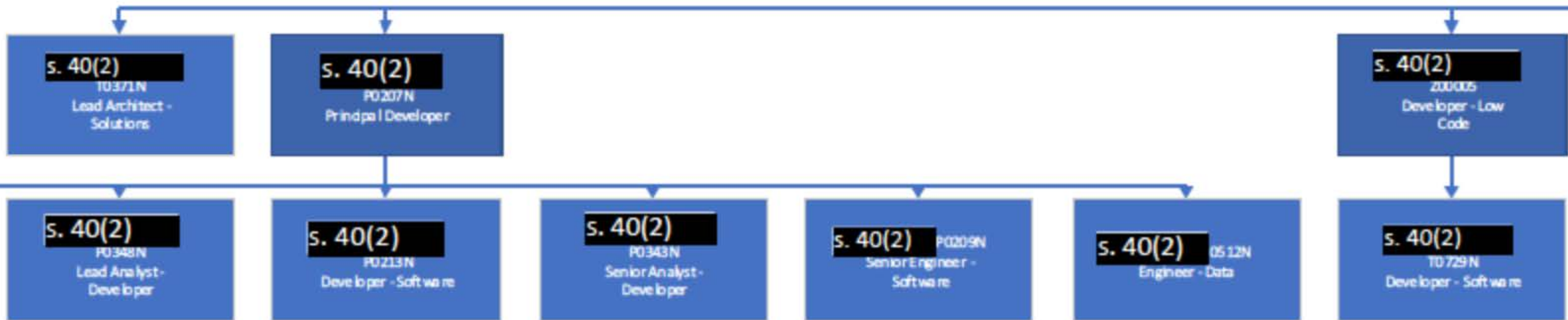

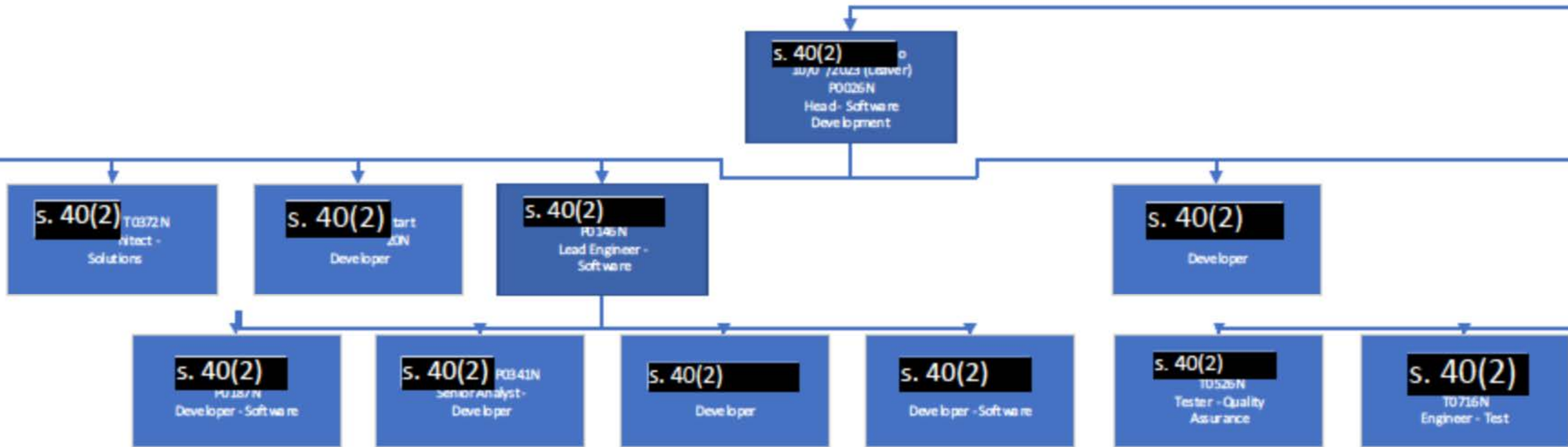

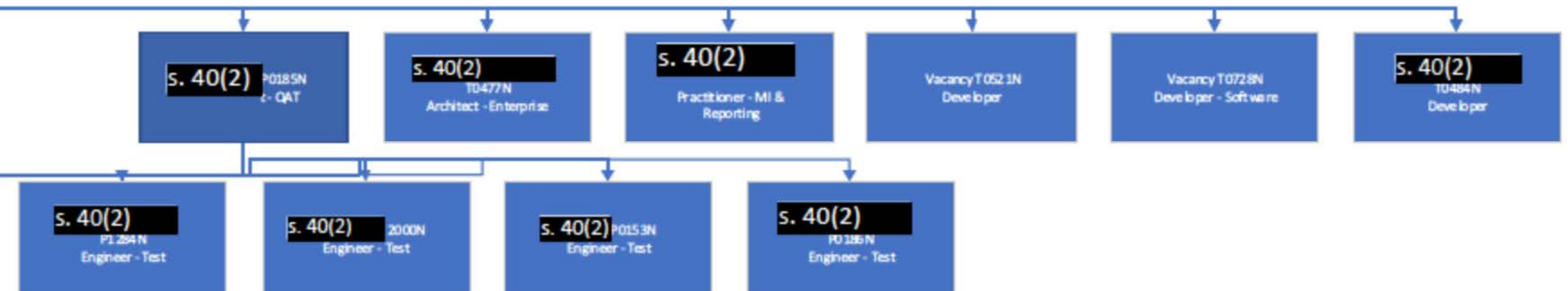

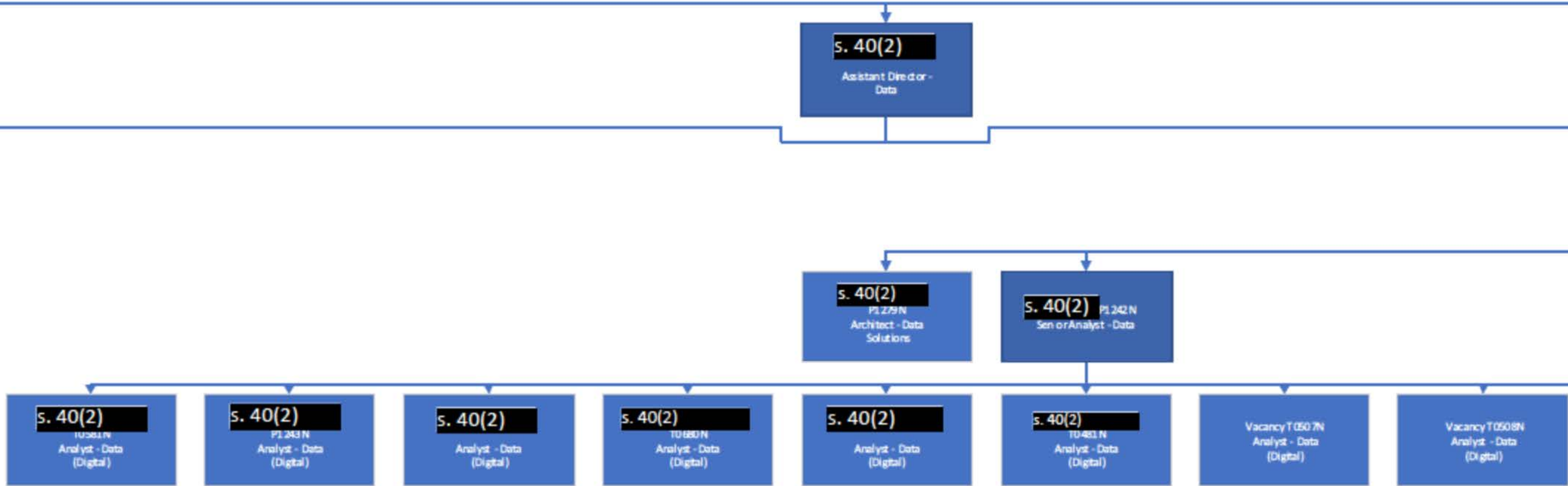

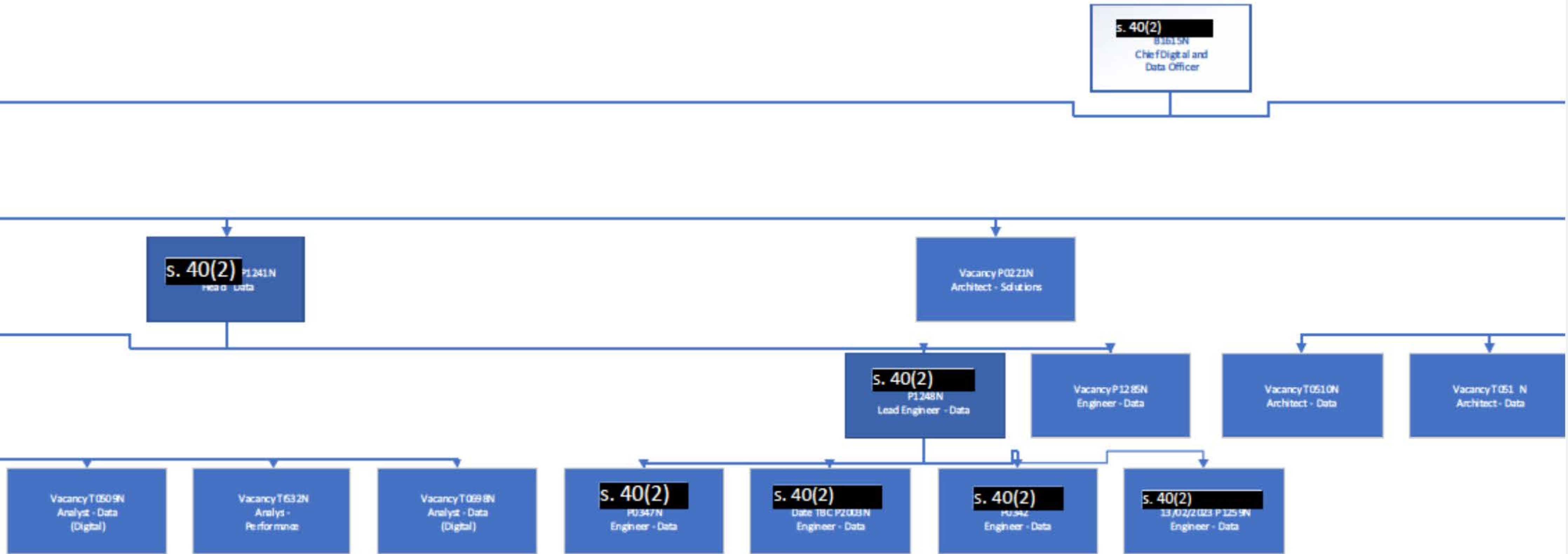

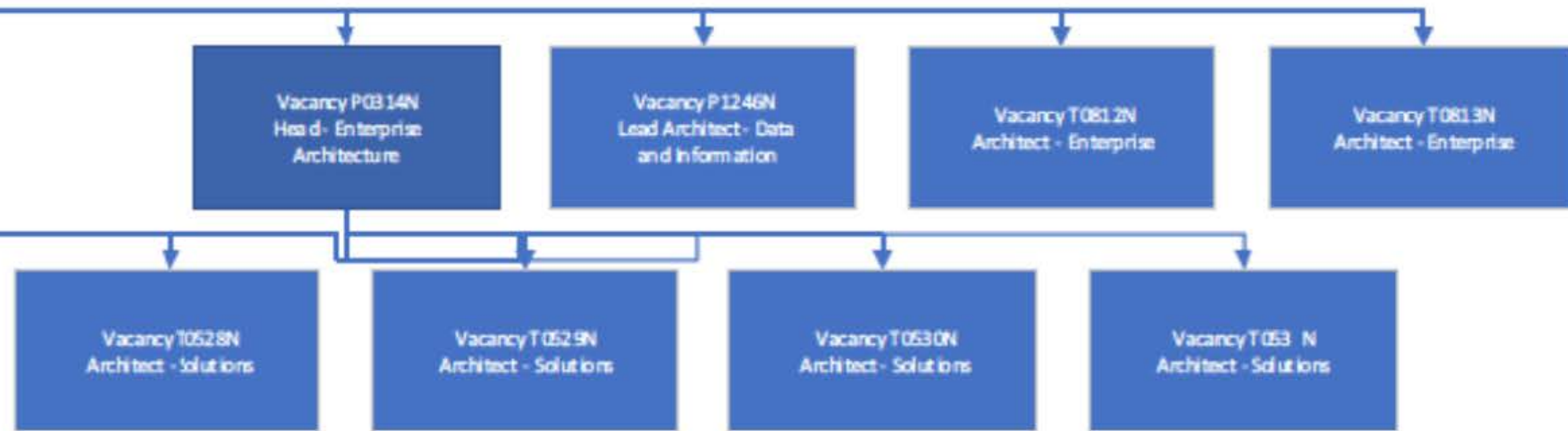

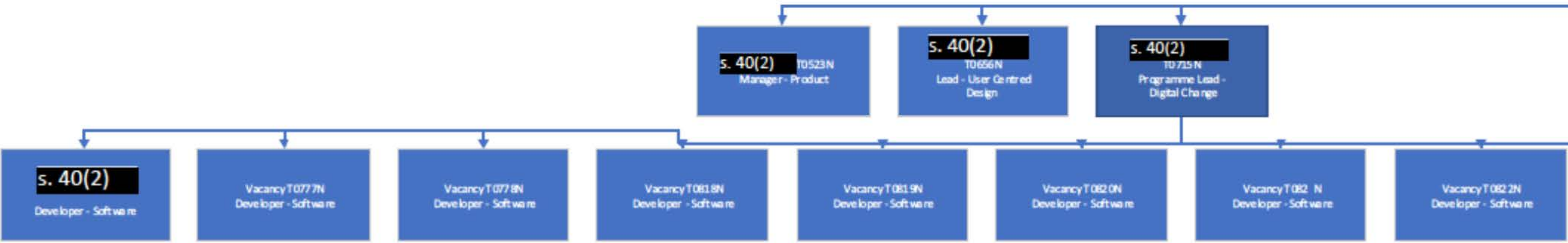

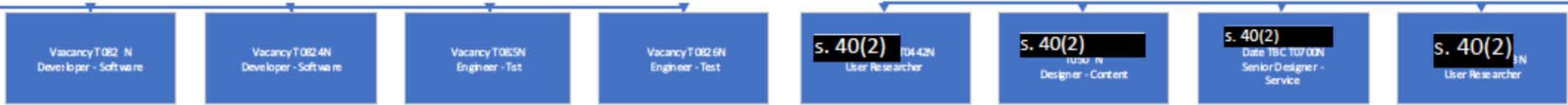

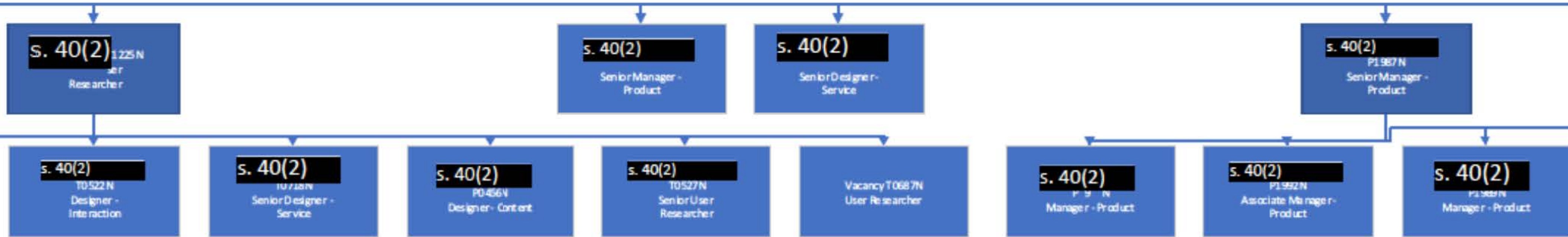

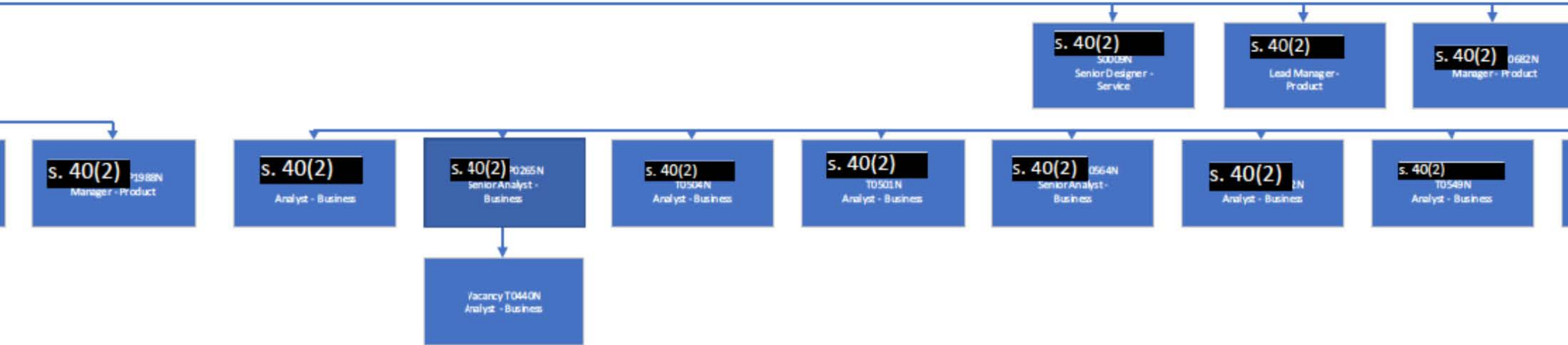

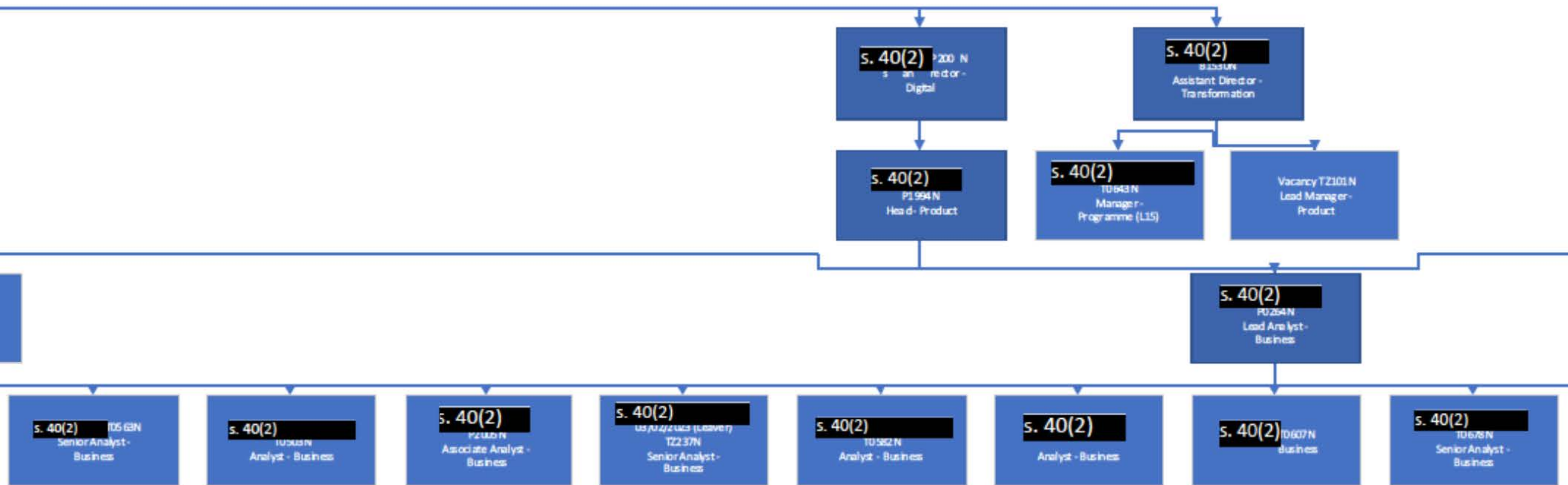

Vacancy P0132N
Senior Analyst -
Business

Vacancy T0500N
Analyst - Business

Vacancy T0562N
Senior Analyst -
Business

Vacancy T0588N
Manager - Change

Vacancy T0606N
Analyst - Business

Vacancy T0638N
Analyst - Business

Vacancy T0688N
Lead Analyst -
Business

Vacancy T0802N
Analyst - Business

