



LIGHTWEIGHT MULTI-ROLE MISSILE (LMM) - ALL VARIANTS LOG CARD

NSN:

Serial Number:	ACA/MACA No:	SLED:	BKI:	ADAC:
-----------------------	---------------------	--------------	-------------	--------------

Issue/Return		Location		
Date	Land/Maritime/Depot	Ship/Vehicle/Depot	MACA/ACA	

Visual Inspection - Notable damage or failed inspection please fill in Section (i)

Date	Dessicant	Pass/Fail	Rank	Name	Signature

(i) Notable Damage⁽¹⁾/Failed Inspection

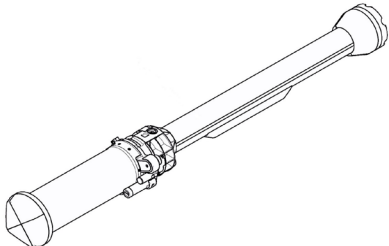
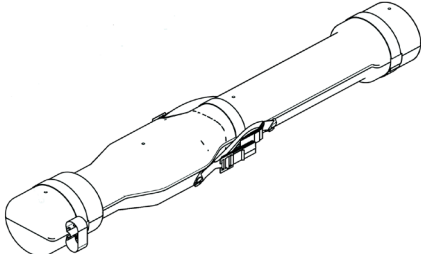
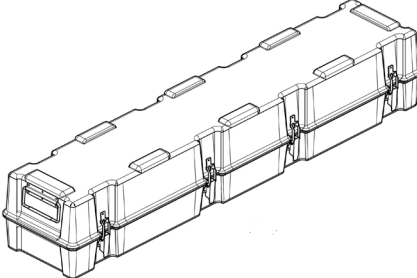
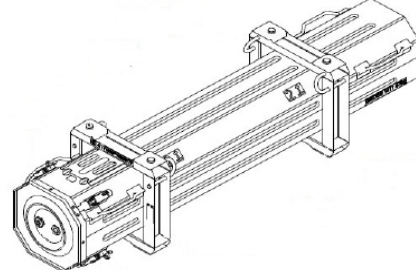
Canister	FHC	ACA	MACA
			

⁽¹⁾ Use images to highlight damage location with an **X** (if on reverse side to the one pictured, please state), add further description and damage nature below image.

ROAD MOVEMENT AND SHIP TRANSFER RECORD

Date	From	To	Total Time (Road)	Ship Transfer (RAS/VERTREP ⁽²⁾)	Rank	Name	Signature

⁽²⁾ LMM Munition restricted to one VERTICAL REPLENISHMENT (VERTREP) evolution as an Underslung Load (USL) iaw SEXSSI 431.

PACKAGING TRANSFER

From	To	Date
MACA/ACA	MACA/ACA	
MACA/ACA	MACA/ACA	

TRUNDLING

Platform/Location (Rack/Pannier)	ACA	Date	KMs	Hours	Hours Total ⁽³⁾	Rank	Name	Signature

When recording transfer of ammunition container, please include ACA/MACA Serial Number.

⁽³⁾ Hours Total is an accumulation of the 'Hours' column.

ON-BOARD / OPERATIONAL STORAGE ENVIRONMENT

Month Ending	Ship / Location	RECORD OF TEMPERATURE EXCEEDANCES (Number of Weeks at) ⁽⁴⁾							Signature
		28.1°C - 30°C	30.1°C - 33°C	33.1°C - 36°C	36.1°C - 39°C	39.1°C - 42°C	42.1°C - 45°C	45.1°C - 48°C	

⁽⁴⁾ SHORAD DT also to be notified in this instance iaw SEXSSI 431 / JSMCR via LMM Shared email addresses as detailed at the base of the form.

AIR CARRIAGE / ON BEAM HOURS

Ship/Location	Container	Date	Air Carriage / On Beam ⁽⁵⁾ Hrs:Mins	Over 90kts ⁽⁶⁾ Y/N	Hours Remaining	Rank	Name	Signature

⁽⁵⁾ 'ON BEAM' hours recording requirement is for LMM in GBAD role only.

⁽⁶⁾ For **LMM OMs** only - if missile is subject to air carriage in excess of 90kts, air carriage time for the duration of this sortie is to be doubled (ie > 90 KIAS, 1 x ACH of actual flight is to be recorded as 2 x ACH iaw DMP 5401-1000 Topic 2B / JSMCR and Wildcat RTS).

FIRING INFO - to be completed by Section Commander/ATO (at Training) or RN Officer of the Quarter (OOQ)

<i>Date Fired</i>	<i>Success/Failed Firing</i>	<i>Platform</i>
MISFIRE/HANG-UP⁽⁷⁾⁽⁸⁾⁽⁹⁾⁽¹⁰⁾		
Has this munition experienced a firing	Misfire/Hang-Up/Unconfirmed	
Which emergency procedure was applied:	Incident Details:	

⁽⁷⁾ To be completed by Section Commander/ATO (Training) or RN Officer of the Quarter (OOQ). If the missile has experienced a firing incident, please include any additional information in the 'Incident Details' box.

⁽⁸⁾ In the GBAD role firing/expenditure is to be recorded iaw A&ER Vol 3, Pam 50, Part 2. Details from 0015 and all Log Cards are to be collated and returned to **DESWpnsShorad-ISS-HVM@mod.gov.uk** (Scans / Photos are acceptable).

⁽⁹⁾ In the Martlet role firing / expenditure is to be recorded iaw BRd 862 and BRd 767 NAO 4694 with returns sent to **DESWpnsLMAS-LMM-Martlet-Shared@mod.gov.uk** (Scans / Photos are acceptable).

⁽¹⁰⁾ If found outside a Defence Establishment, this Log Card is to be returned to Defence Munitions via **DESWpnsDM-Gos-Customer-Services@mod.gov.uk** and above email addresses notified.

