

Construction Traffic Management Plan

DOCUMENT REF: PELHAM SOLAR LIMITED CTMP – REV 2

Project: Pelham 49.99MW Solar Scheme



Introduction.

Following the comments submitted by Hertfordshire County Council Highways and Essex County Council Highways, in reference to application S62A/22/006, the Construction Traffic Management Plan has been amended. The main change to note is the construction route.

The purpose of this document is to propose how construction traffic including site personnel movements will be safely controlled at the Pelham Solar Site by the developer and its sub-contractors, working on behalf of Statera Energy.

Whilst the document covers some of the detail that would be expected within a Transport Statement, the main focus is the management of construction traffic, throughout the construction phase of the solar farm. It should therefore be read as a Construction Traffic Management Plan (CTMP) against which any specific conditions can be applied to ensure the safe management of traffic throughout the construction period.

The site is located to the south of Ginns Road, Berden Farm, Berden, Uttlesford, SG9 0HZ
 Site entrance grid ref: X (Easting) = 546183, Y (Northing) = 229662

The site location is shown by Figure 1.

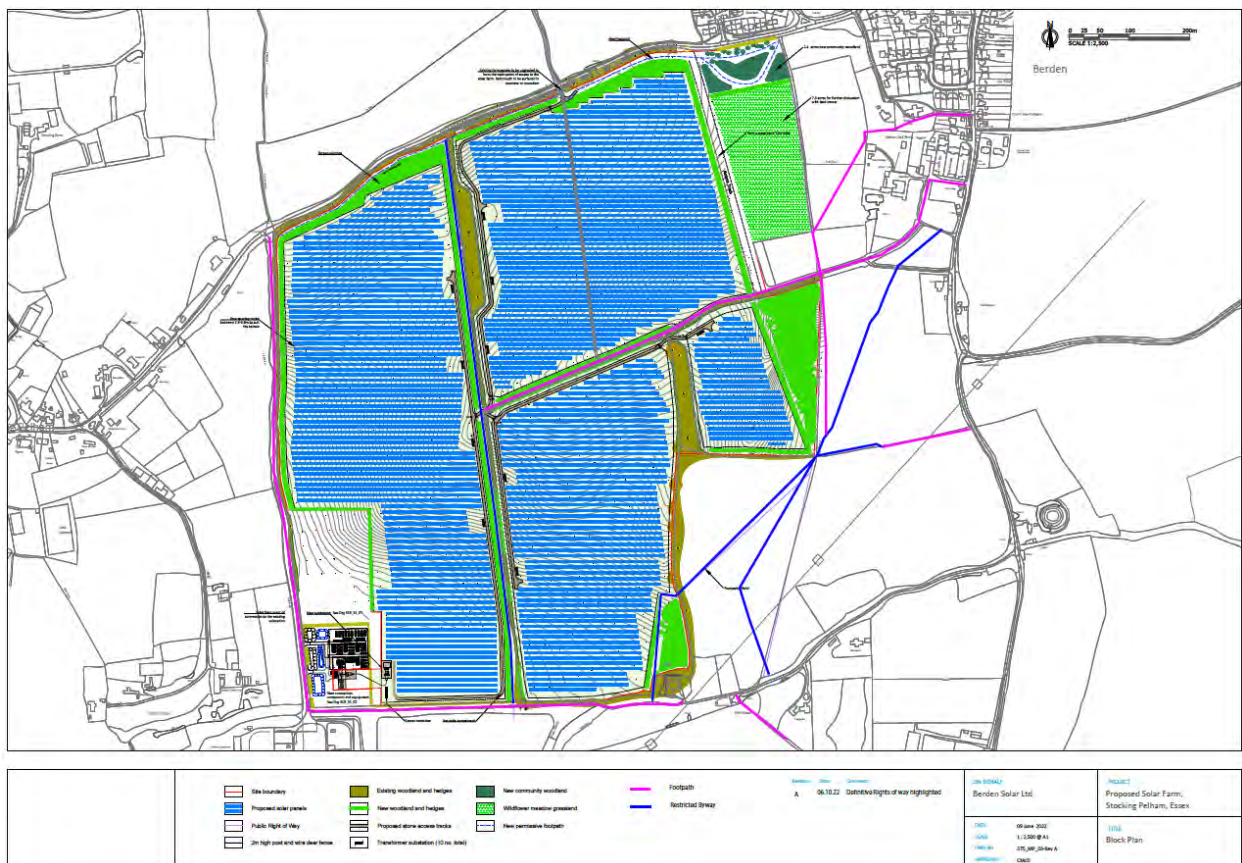

The site is located is Uttlesford therefor the Highway Authority is Essex County Council.

Site Working Times (TBC)

It is proposed that construction will be undertaken during the following times:

Day:	Winter working (Oct – Mar):	Summer working:
Monday	07:00 – 18:00	07:00 – 20:00
Tuesday	07:00 – 18:00	07:00 – 20:00
Wednesday	07:00 – 18:00	07:00 – 20:00
Thursday	07:00 – 18:00	07:00 – 20:00
Friday	07:00 – 18:00	07:00 – 20:00
Saturday	07:00 – 13:00	07:00 – 13:00
Sunday	No works	No works
Bank Holidays	No works	No works
Site Security	17:00 – 07:30 every day	19:00 – 07:30 every day

Construction Overview

The development will be subject to a 6-month construction period, which will comprise a relatively intense 3-month period at the start where all the components are delivered to the site and the following three months will comprise the construction of the solar farm.

An average of up to 50 construction workers are forecast to be on site during peak times during the construction period. A temporary car parking area (including spaces for minibuses) will be provided on the site within a contractor's compound. Parking will therefore be contained within the site and no unnecessary parking will occur on the local highway network

The location of where staff will travel from is unknown at this stage as it will depend on the appointed contractor. However, a number of the non-local workforce will stay at local accommodation and general operatives will be transported to the site by minibuses to minimise the impact on the local highway network. The number of car trips to the site will be minimised to those senior staff such as project managers and the Health and Safety Executive.

The construction period will include the use of HGVs to bring the equipment onto the site and this will be strictly managed to ensure that vehicle movement is controlled and kept to a minimum. It should be noted that unlike wind farms, the construction of a solar farm does not require equipment to be delivered by abnormal loads (i.e. vehicles over 16.5m in length). There could be up to 20 lorries per day arriving and departing during the peak construction period.

The total number of HGVs is estimated to be 350, over the 6-month construction period this averages at 2.2 HGVs per day (over a 6-day week), however this number is likely to be higher during the enabling and ground works phases and lower during the commissioning period.

Deliveries to the site will be managed to avoid highway network weekday peak hours. Construction work and construction traffic movements shall not take place on Sundays, bank holidays or after 13.00 on a Saturday unless such work is associated with an emergency or with the prior written consent of the local authority

Proposed routes to and from the Pelham Construction Site

Construction traffic will come from M11 with the majority of traffic travelling from the south. The construction vehicles will come off the M11 at Junction 8 and be routed to site via the A120. Traffic will take the first exit at the Homebase roundabout on to the B1383 before turning immediately right on to Michaels Road. Construction traffic will then take the third exit onto Hazel End Road, following Hazel End Road on to Carters Hill, through the village of Manuden and continuing north onto Manuden Road. Construction traffic will then turn left on to Berden Road, passing through the village of Berden and on to Ginns Road, before turning left into the site, via the existing agricultural access, which will be upgraded.

The new proposed route is the same route Statera Energy used to build out Pelham Storage.

The preferred route to the Pelham Solar Construction Site is shown in red on the map below:

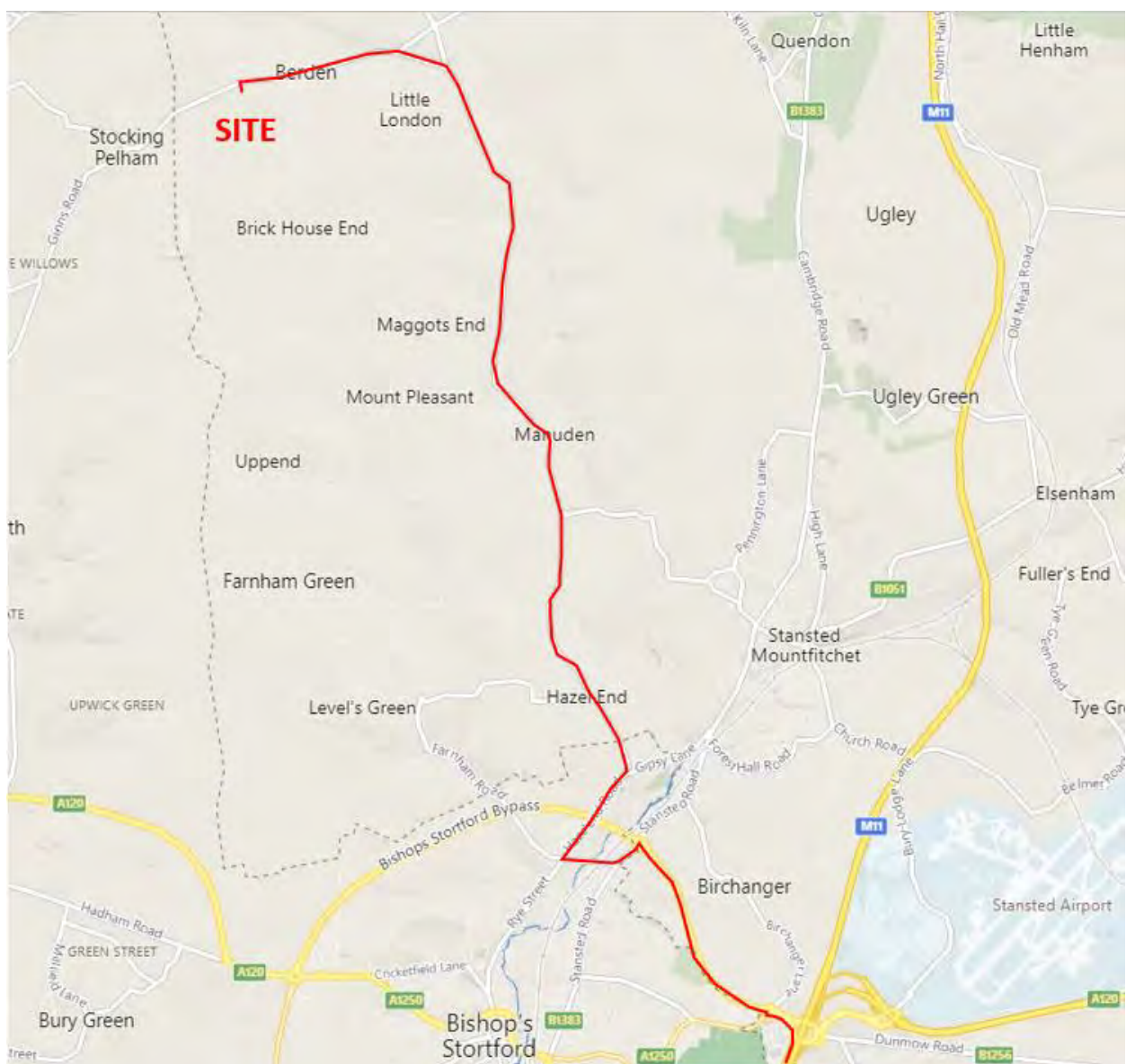

Site Access and Site Plan

Access to the site will be from the existing private agricultural access off Ginns Road. The existing access track has a concrete apron of approximately 8m width and 5m depth adjacent the Ginns Road carriageway before reverting to a consolidated stone track of approximately 3.25m width through the field itself. It is currently gated at a point approximately 7m back from the edge of carriageway. It is proposed that this existing access be upgraded to facilitate vehicle access during construction of the Solar Farm. It will also be retained post completion of the construction operations to allow for future maintenance access to the Solar Farm site, please refer to the Access Technical Note for further detail.

During construction the Site will be accessed via a Site Security Checkpoint located at the entrance to the construction site. Unrestricted access is not allowed without undertaking a Site-Specific Induction, Assessment and Approval. In the absence of this training and approval, visitors to site will always be escorted by a site member in possession of this training and authorisation. A temporary compound area will be established next to the site to allow for the set down of HGVs and materials relating to the construction of the site. It is proposed the Pelham Solar Site will be a Safe 6 site and all personnel working or carrying out deliveries to site will require as a minimum Safety Helmet (Hard Hat), Hi-Vis Tabard, Coveralls, Gloves, Light Eye Protection, Safety Boots. For temporary visitors spare sets of Light Eye Protection and Hard Hats will be provided but it is the expectation that all deliverers/collection persons will have all the equipment with them. It is a requirement that all site personnel and visitors sign in and out of the site on all occasions.

The Site Manager or his designated deputy will be responsible for supervising, controlling and monitoring vehicle movements to and from the site as well as whilst the vehicle is on site. Ensuring that there are suitable arrangements for the safe delivery and collection of the vehicle load. All plant, delivery/collection vehicles and cranes will be supervised by a Banksman when reversing. Height Restriction Barriers (Goal Posts) will be installed where there is a potential for accidental contact with overhead infrastructure. Similarly restricted access areas will be identified and barriered. Site personnel vehicles will be parked in a designated area connected to the Site Welfare Area via a Safe Pedestrian Access/Egress Route.

Access Route Images



Junction 8 on the M11 heading north



The roundabout following junction 8



Exit 2 of the roundabout on the A120 heading west bound



Birchanger roundabout



Exit 2 of the Birchanger roundabout, towards Hertford



A120 heading north west



Homebase roundabout



Exit 1, towards Bishops Stortford



Take right turn towards Farnham and Manuden

Google



Follow route along Michael's Rd

Google



Take exit 3 at roundabout



Take exit onto Hazelend Road





**Hazeland Road continues on to
Carters Hill toward Manuden**

Google



**Pass through Manuden
and onto The Street**

Google



Continue onto Manuden Road



Take left turn onto Berden Road





Onto Ginns Road



The agricultural access, which will be upgraded as part of the development

Highway Maintenance

Prior to construction taking place a Highway Condition Survey will be undertaken, the survey area will be agreed with Uttlesford District Council. The Highway Condition Survey will ensure that any potential damage caused to the highway by the construction vehicles can be accounted for and rectified to the satisfaction of the highway authority.

A temporary construction route signage scheme will be in place along the route to ensure drivers know which route to follow.

Site Entrance

The site entrance will use the existing agricultural access track. It is proposed that this existing access be upgraded to facilitate vehicle access during construction of Pelham Solar. It will also be retained post completion of the construction operations to allow for future maintenance access to Pelham Solar.

Site Access Tracks

The topsoil for other internal tracks will be removed to a depth of 100mm. A terrain membrane will be laid in the excavated access path and filled with 200mm of 75mm CR stone, which will then be compacted down to 100mm to provide a suitable surface for vehicles.

The access path will be approximately 3.5m in width.

The access path will be approximately 3.5m in width. Figure 1 is a photo of a similar access path.

Figure 2. Sample Access Track



Construction Compound

A temporary construction compound will be created, see plan *Temporary Construction Compound (GP_CC_01)*. This area will be used for lorry turning and as set down area during construction.

All shuttle vehicles will be able to enter the site and unload within the compound area. There will be no queuing, parking or unloading on the public highway.

Unloading

The inverters and substation equipment will be unloaded by crane. The crane requires a swivel radius of at least 6m. To facilitate unloading it is recommended maintaining a distance of at least 2m to neighbouring obstacles such as fences and trees, overhead power lines also need to be take into consideration.

Figure 3. Crane Turning Access

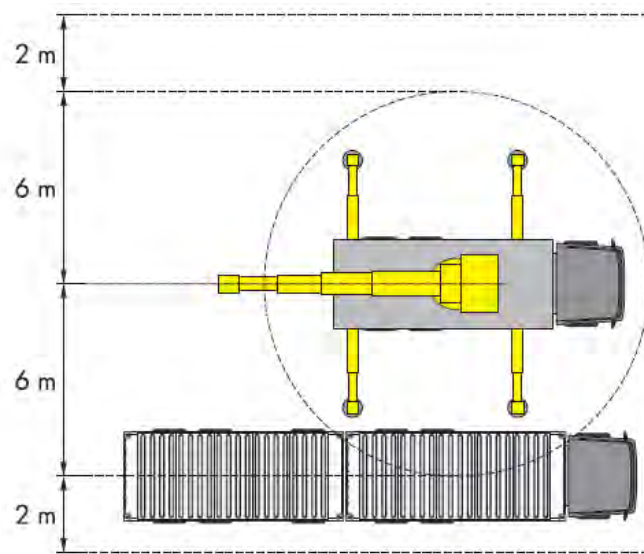

Delivery & Collection Permitted Times

Where possible deliveries and collections will be restricted to the hours of 09:30 – 16:00 weekdays.

Vehicle Wheel Washing Facilities

All vehicles leaving site will be inspected prior to passing through the security barrier to ensure that they are deemed suitable to access the public highway. Wheel cleaning facilities will be provided to ensure that the potential problem will be minimised.

Site Materials Migrating on to the Public Highway.

At the Pelham Site the generation of waste material including concrete washings and other site detritus will be controlled by a Site Waste Management Plan (SWMP). This will be submitted to the LPA before the development starts.

Impact on other Highway Users

It is not envisaged that the Construction Site will have any impact on other users caused by delays accessing the site. Arrangements will be made with other users of the access road to ensure that in times of peak traffic movements that no-one will be overly inconvenienced. These arrangements will be organised locally by the Site Manager.

Arrangements for Pedestrians.

During construction, the contractor will ensure that all Public Right of Way remain open and accessible at all times.

Appropriate signage will be used to warn the public of the existence of construction vehicles and to warn construction vehicles to give priority to Public Right of Way users.

For the majority of the construction works duration the number of outwards movements of construction vehicles in any one day will be between 10 and 30 HGVs. These movements will also most likely be during weekdays outside of peak times and not on Saturday or Sundays.

It should be noted that apart from the construction phase of the development where there would be an increase in traffic movements, once installed, the development will be unmanned and a passive installation with minimal extra traffic movement; probably no more than 5 vehicles a week.

Existing Waiting & Loading Restrictions

Not applicable at this site.

Storage of Materials & Equipment on Highway.

This is not applicable at the Pelham Site all storage will be on the construction site at the site compound area.

Installed Traffic Diversion Measures

Not required at this site.

Spoil & Waste Removal

All spoil generated on the Pelham site will be transported away using a combination of skips and grab-lorry depending on volume and stage of the works.

Other wastes will be disposed of using skips

Scaffolding Erection near or on the Public Highway

Scaffolding will not be erected near any highway or public area on this project.

Operational Phase

Solar Farms require little maintenance. The site will be unmanned and a passive installation with post-construction activity limited to occasional visits to:

- Undertake any checks, maintenance and adjustments to infrastructure as required.
- Very rarely an inverter may need replacing

Access for the operational phase of the Solar Site will be via the upgraded agricultural access track.

Decommissioning

The panels have an operational life of between 35 – 40 years with regular servicing, thus it is not anticipated that many will need to be replaced over the life of the system. Once the panels reach the end of their life, or earlier if a term is imposed through planning conditions, the site will be decommissioned.

All electrical infrastructure will be removed leaving the site compound area to be returned for farming. All traffic to decommission the site will use the National Grid owned road/ and or a private access road.

The application is for a temporary consent meaning once the time has lapsed the land reverts to its original use, in this case agricultural. The land will not be classed as previously developed.

APPENDICIES

APPENDIX 1 – Site Layout

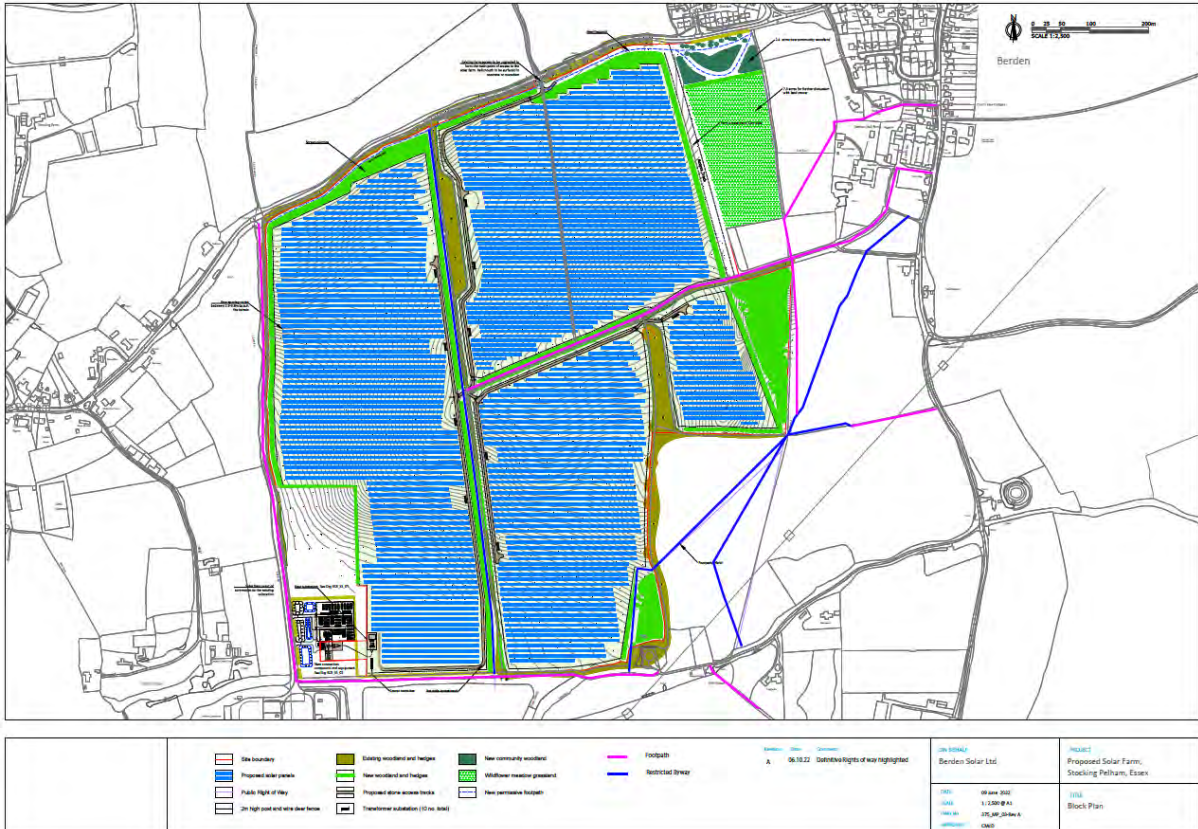

APPENDIX 2 – Access cross section drawing

