

REAR ELEVATION

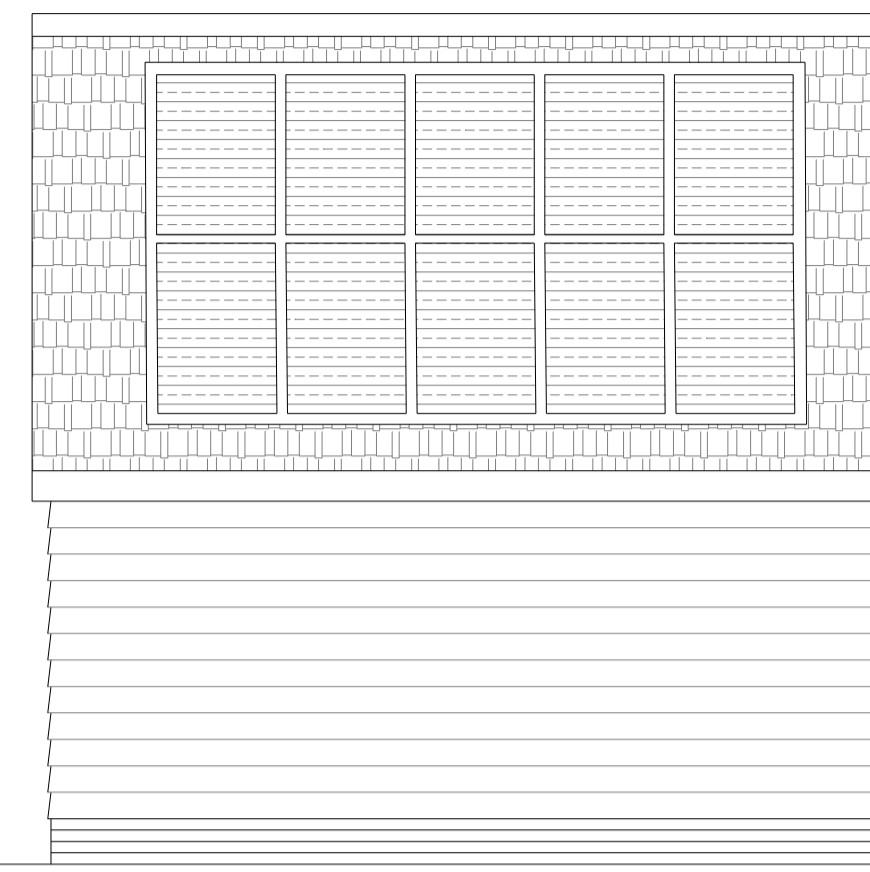

SIDE ELEVATION

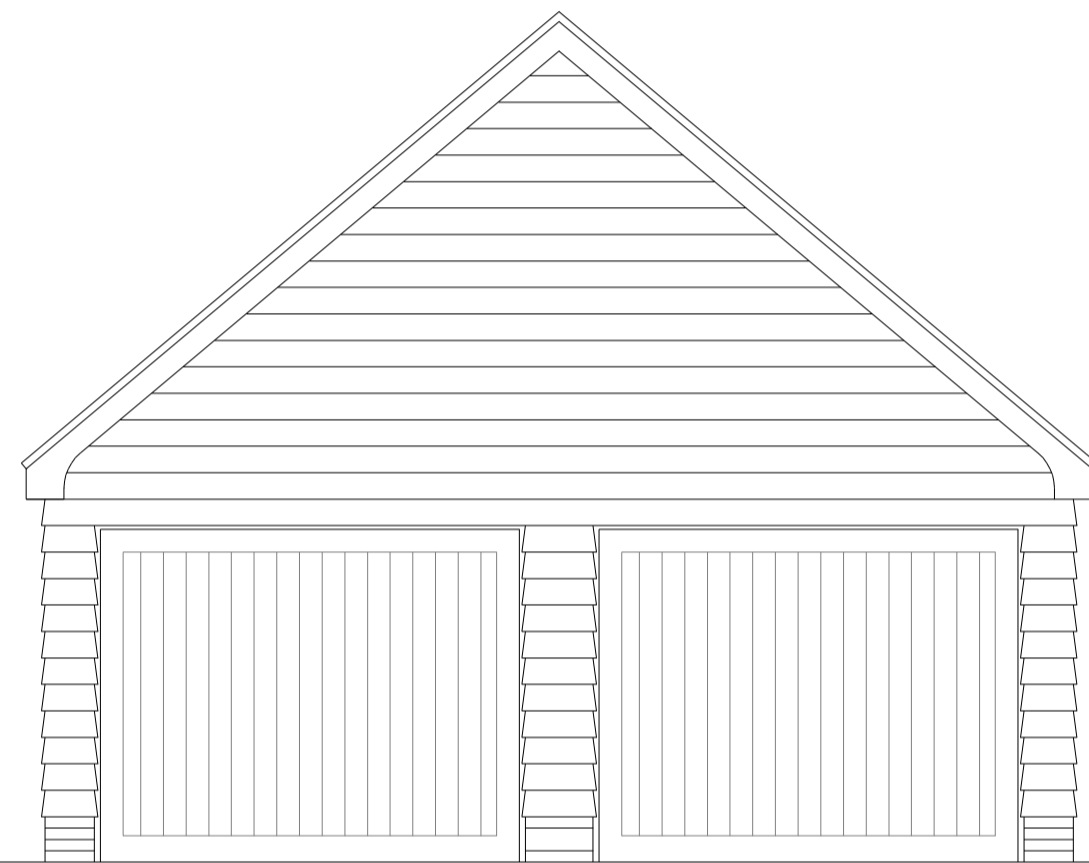

FRONT ELEVATION

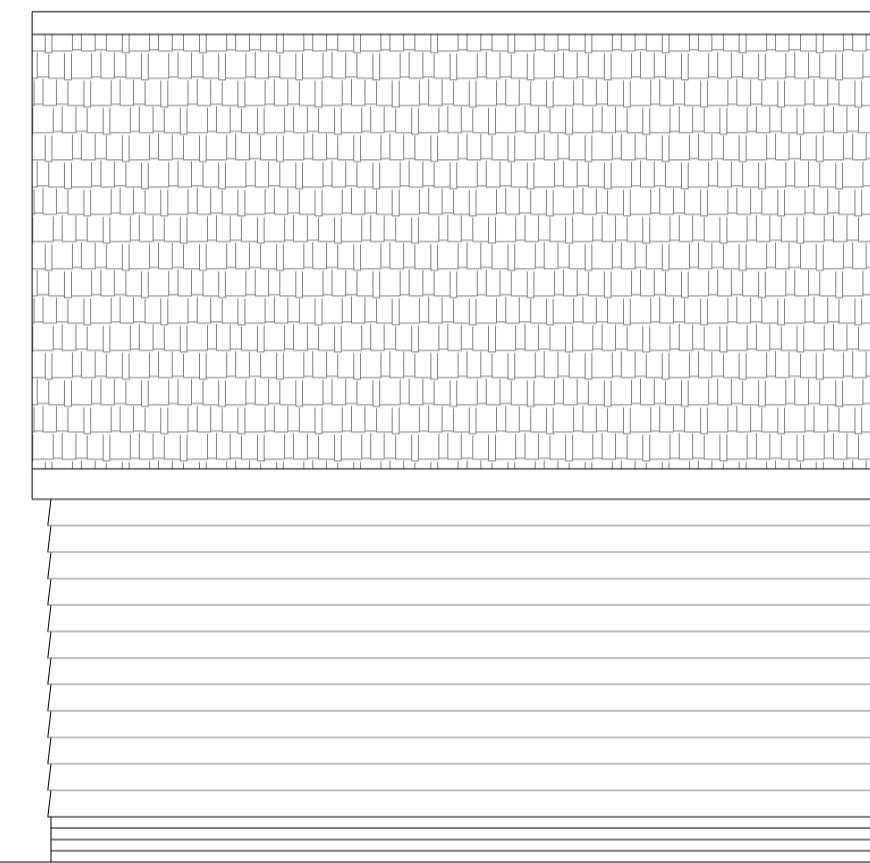

SIDE ELEVATION

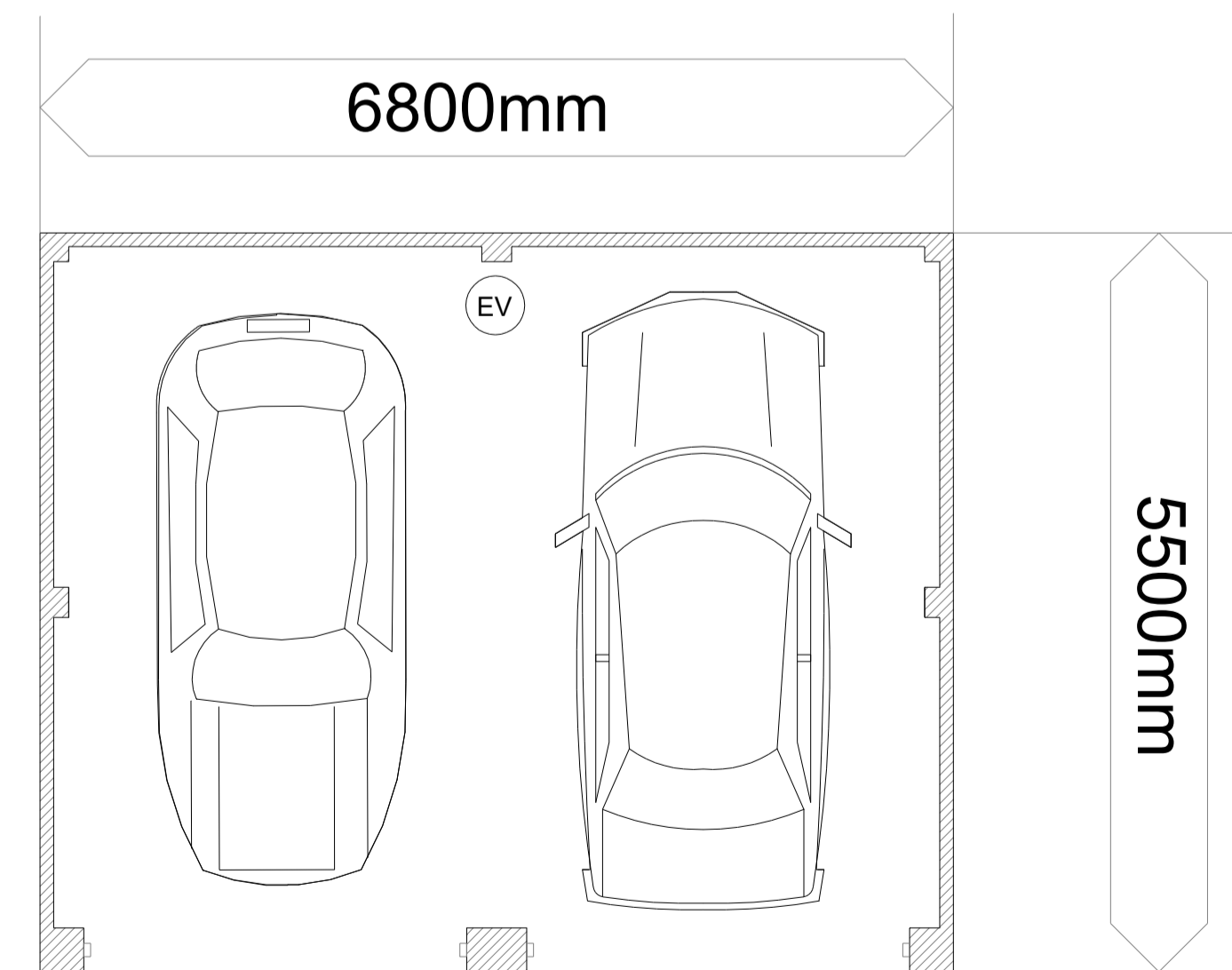

FLOOR PLAN - G1 AND G8
UNITS 10 & 17

FINISHES SCHEDULE

Roof to be finished with Eternit slate tiles complete with Eternit slate dry ridge.

Solar panels to be installed "within" the roof finish to ensure the top of the solar panels are in line with the adjoining slate roof.

External walls to be facing brick plinth in bricks to match main house. From top of plinth to eaves, 175mm feather edge board stained black.

All eaves and soffit to be timber a stained black.

All gutters and down pipes to be black Upvc

All garage doors to be solid timber

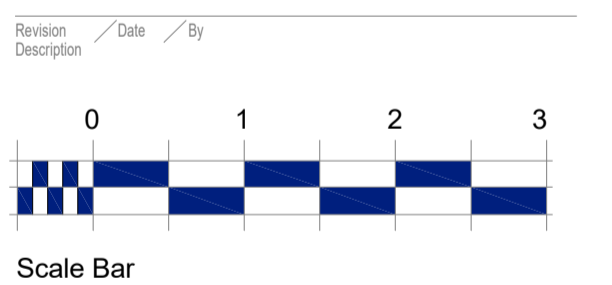

ANTHONY JANE
ARCHITECTURE & INTERIORS
1A Eves Corner, Danbury, ESSEX, CM3 4QF
E: technical@anthonyjane.com

Project	CANFIELD MOAT HIGH CROSS LANE WEST LITTLE CANFIELD CM6 1TD		
Client	Mr ANDY SMITH		
Drawing	GARAGE BLOCKS G1 & G8 PLANS AND ELEVATIONS		
Drawing	Drawing Use	Date	Mar 2022
	Information	Scale	1:50 @ A1
Drawing number	10949/A1/18		Rev ---