

Dated

[•]

(as the **GENERATOR**)

and

LOW CARBON CONTRACTS COMPANY LTD

(as the **CFD COUNTERPARTY**)

PRIVATE NETWORK CFD AGREEMENT
RELATING TO [*name of Project*]

CONTENTS

1.	Definitions and interpretation	1
2.	Agreement	12
3.	Term	12
4.	Metered Output	12
5.	Generation Technology Type	16
6.	Generator Undertakings: General and Route to Market	18
7.	Termination Events: Route to Market	20
8.	Generator Undertakings: Metering	21
9.	Conditions Precedent and Milestone	28
10.	Not Used	32
11.	Installed Capacity Estimate and Required Installed Capacity	32
12.	Changes in Law	32
13.	Payment Calculations: STRIKE Price	33
14.	Balancing System (BSUOS/RCRC) and TLM(D)	33
15.	Curtailement	33
16.	Private Network Metering Dispute	33
17.	Pro Forma Notices	35
18.	Notices	36
19.	Agent for Service of Process	36
20.	Disapplication of Conditions	36
	Annex 1 (Description of the Facility)	38
	Annex 2 (Modification Agreement)	39
	Annex 3 (Facility Generation Type)	40

Annex 4 (Fuelling Criteria)	42
Annex 5 (Project Commitments)	45
Annex 6 (Private Network Metering Operational Framework)	54
Annex 7 (Private Network Technical System Requirements)	83
Annex 8 (Notices)	102

THIS PRIVATE NETWORK CFD AGREEMENT is dated _____ (the “**Agreement Date**”) and made between:

- (1) [●], a company incorporated under [●] whose registered office is [●] and whose company number is [●] (the “**Generator**”); and
- (2) **LOW CARBON CONTRACTS COMPANY LTD**, a company incorporated under the laws of England and Wales whose registered office is Fleetbank House, 2-6 Salisbury Square, London EC4Y 8JX and whose company number is 08818711 (the “**CfD Counterparty**”).

BACKGROUND

- (A) This Private Network CfD Agreement is entered into following the applicable contract allocation or negotiation process established under or by virtue of the EA 2013.
- (B) The Generator has satisfied the Eligibility Criteria.
- (C) The CfD Counterparty is a company wholly owned by the UK Government and is entering into this Private Network CfD Agreement solely for the purpose of implementing the provisions of the EA 2013.
- (D) This Private Network CfD Agreement is a CfD Agreement for the purpose of the Conditions.
- (E) This Private Network CfD Agreement, together with the terms and conditions set out in version 4 of the document entitled “FiT Contract for Difference Standard Terms and Conditions” as at 25 November 2021, constitute an agreement entered into on "standard terms" (as defined in section 11(1) of the EA 2013).

IT IS AGREED as follows:

1. DEFINITIONS AND INTERPRETATION

- 1.1 Except as expressly specified in this Private Network CfD Agreement, words and expressions defined in the Conditions shall have the same meanings when used in this Private Network CfD Agreement. Where a term is defined in both this Private Network CfD Agreement and in the Conditions, the definition in this Private Network CfD Agreement shall apply instead of the definition in the Conditions.
- 1.2 In this Private Network CfD Agreement and its recitals:

“**Agreement Date Provisions**” means Part 1 (*Introduction*), Part 2 (*Term*), Part 3 (*Conditions Precedent and Milestone Requirement*), Condition 8 (*Application*), Condition 9 (*Definitions: Part 5A*), Condition 14 (*Strike Price Adjustments*), Condition 16 (*Application*), Condition 17 (*Definitions: Part 5B*), Condition 20 (*Strike Price Adjustments*), Condition 24 (*Default Interest*), Condition 25 (*Set-off*), Condition 26 (*Deductions and withholdings*), Condition 27 (*Payment accounts*), Condition 28 (*Generator representations and warranties*), Condition 29 (*CfD Counterparty representations and warranties*), Condition 30 (*Generator undertakings: General*), Condition 32 (*Generator undertakings: Information provision and no cumulation of Subsidy, state aid and/or union funding*), Part 12 (*Termination*), Part 14 (*Dispute Resolution*) to Part 17 (*Miscellaneous*)

(inclusive), Schedule 1 (*Conditions Precedent*), Annex 1 (*Calculation of Termination Amount*), Annex 2 (*Change Control Procedure*), Annex 3 (*Form of Direct Agreement*), paragraph 1 of Part A of Annex 7 (*FMS arrangements, Sustainability Criteria, RQM Calculation Methodology and ACT Efficiency*) and Annex 8 (*Pro forma notices*);

“**Apparatus**” means all equipment in which electrical conductors are used or supported or of which they form part;

“**Baseload Difference Amount**” has the meaning given to that term in Condition 9 (as amended pursuant to Clause 4.5);

“**Boundary Point**” means the point at which any Apparatus or Plant which does not form part of the Total System is connected to the Total System;

“**Boundary Point Metering System**” means the Metering System which measures the volume of electricity (expressed in MWh) flowing at the Boundary Point;

“**CfD Counterparty Metering Breach Notice**” has the meaning given to that term in Condition 31.2 (as inserted into the Conditions pursuant to Clause 8);

“**CfD Standard Terms Notice**” means a notice issued pursuant to regulation 9 of the Contracts for Difference (Standard Terms) Regulations 2014 (as amended);

“**Check Meter**” means the Meter that the Generator is required to calibrate, install, commission and maintain pursuant to and in accordance with the MOF and the TSRs in respect of each Main Meter to measure Metered Volume (excluding, where the Facility is a Dual Scheme Facility, the Imported Input Electricity);

“**Clock Change Day**” means the 24 hour period commencing at 00:00 during which a step change in local time occurs in accordance with the beginning and ending of summer time in Great Britain as defined by the Summer Time Act 1972;

“**Code Subsidiary Documents**” has the meaning given to that term in the BSC;

“**Communications Equipment**” means, in respect of any Metering Equipment:

- (A) the terminating equipment (which may include a modem) necessary to convert metering data from such Metering Equipment into a state for transmission to the CfD Counterparty or the CfD Settlement Services Provider; and
- (B) the exchange link which is connected to that terminating equipment, including any Outstation;

“**Conditions**” means the terms and conditions set out in version 4 of the document entitled “FiT Contract for Difference Standard Terms and Conditions” as at 25 November 2021 (as amended, modified, supplemented or replaced by this Private Network CfD Agreement and as may be amended, modified, supplemented or replaced from time to time in accordance with the Conditions);

“**Distribution System**” has the meaning given to that term in section 4(4) of the EA 1989;

“Electrical Schematic Obligation” has the meaning given to that term in Condition 31.12 (as inserted into the Conditions pursuant to Clause 8);

“Expected Generation Output Data” means:

- (A) the Generator’s estimate of the total electrical output of the Facility (expressed in MWh), which is as it will be measured by the Facility Metering Equipment at the Boundary Point, for each year (from 1 April to 31 March inclusive) of the remainder of the Term, and taken:
 - (i) before having made any TLM(D) related loss adjustments (if Part 10 (*Balancing System (BSUoS/RCRC) and TLM(D)*) of the Conditions is expressed to apply to the Contract for Difference in the CfD Agreement); and
 - (ii) before having made any Line Loss Factor adjustments;
- (B) the Generator’s estimate of the expected average value of the Renewable Qualifying Multiplier for each year (from 1 April to 31 March inclusive) of the remainder of the Term (provided that this paragraph (B) shall apply only if the Renewable Qualifying Multiplier is expressed to apply to the Contract for Difference in the CfD Agreement);
- (C) the Generator’s estimate of the expected average value of the CHP Qualifying Multiplier for each year (from 1 April to 31 March inclusive) of the remainder of the Term (provided that this paragraph (C) shall apply only if the CHP Qualifying Multiplier is expressed to apply to the Contract for Difference in the CfD Agreement);
- (D) in relation to the estimates referred to at paragraphs (A) - (C), an explanation of the underlying assumptions and key uncertainties provided in a format to be determined by the CfD Counterparty (acting reasonably); and
- (E) where a submission of the estimates or data referred to in paragraphs (A) - (D) has been made by the Generator to the CfD Counterparty, and where such estimates or data has changed significantly since the last submission, the reasons for those changes.

“Facility” means *[the generating facility comprising all assets (including all Generating Units but excluding all assets forming part of an Electricity Storage Facility) which are used (or intended to be used) to generate or deliver electricity and which:*

- (A) *were taken into account by the Generator in determining the Initial Installed Capacity Estimate;*
- (B) *are (except as otherwise agreed in writing by the CfD Counterparty) situated within the area shaded on the map provided pursuant to paragraph (C)(ii) of Part A of Schedule 1 and which has the geographical coordinates specified in Annex 1 (Description of the Facility); and*
- (C) *are described pursuant to Paragraph (C)(i) of Part A of Schedule 1,*

adjusted, where the context requires, to take due account of any changes to the composition of such assets arising as a result of, or giving rise to:

- (i) any reduction to the Installed Capacity Estimate pursuant to Condition 5 (Adjustment to Installed Capacity Estimate: Relevant Construction Event);*
- (ii) any adjustment to the Installed Capacity Estimate pursuant to Condition 6 (Adjustment to Installed Capacity Estimate: Permitted reduction); and*
- (ii) the agreement or determination of the Final Installed Capacity pursuant to Condition 7 (Final Installed Capacity; Maximum Contract Capacity),*

and otherwise excluding all assets forming part of the Transmission System or a Distribution System]¹ / [the generating facility comprising:

(A) all assets (including all Generating Units but excluding all assets forming part of an Electricity Storage Facility) which are used (or intended to be used) to generate or deliver electricity and which:

- (i) were taken into account by the Generator in determining the Initial Installed Capacity Estimate;*
- (ii) are (except as otherwise agreed in writing by the CfD Counterparty) situated within the area shaded on the map provided pursuant to paragraph (C)(ii) of Part A of Schedule 1 and which has the geographical coordinates specified in Annex 1 (Description of the Facility); and*
- (iii) are described pursuant to Paragraph (C)(i) of Part A of Schedule 1,*

adjusted, where the context requires, to take due account of any changes to the composition of such assets arising as a result of, or giving rise to:

- (a) any reduction to the Installed Capacity Estimate pursuant to Condition 5 (Adjustment to Installed Capacity Estimate: Relevant Construction Event);*
- (b) any adjustment to the Installed Capacity Estimate pursuant to Condition 6 (Adjustment to Installed Capacity Estimate: Permitted reduction); and*
- (c) the agreement or determination of the Final Installed Capacity pursuant to Condition 7 (Final Installed Capacity; Maximum Contract Capacity);*

(B) all assets owned by the Generator and comprised or to be comprised within the Offshore Transmission System of such generating facility except for the purposes of:

¹ Drafting note: Drafting in the preceding set of square brackets is to be used for all Facility Generation Technologies other than Offshore Wind (including in this exclusion Floating Offshore Wind).

- (i) in Condition 1.1, the definitions of **“Competent Authority”**, **“Discriminatory Change in Law”**, **“Eligibility Criteria”**, **“Foreseeable Change in Law”**, **“Generation Tax Liability”**, **“QCiL Capital Costs”**, **“QCiL Capital Savings”**, **“QCiL Construction Event”**, **“QCiL Construction Event Costs”**, **“QCiL Operations Cessation Event”**, **“Qualifying Shutdown Event”**, **“Required Authorisation”** and **“Specific Change in Law”**;
- (ii) Conditions 28.2(A), 30.1(E), 31.16, 36.1, 48.2 and 50.1; and
- (iii) paragraph 9.3 of Annex 3 (Form of Direct Agreement) to the Conditions, and otherwise excluding all other assets forming part of the Transmission System or a Distribution System²;

“Facility Metering Equipment” means the Metering Equipment measuring the flows of electricity associated with the Facility, its Metering System and, in the case of a Dual Scheme Facility, the Metering Equipment (including the Boundary Point Metering System) used to measure the Imported Input Electricity of the Generating Station;

“Facility Voltage Class” means the voltage class of the Facility as notified to the CfD Counterparty in accordance with Paragraph 2.5(B) of Part B (*Further Conditions Precedent*) of Schedule 1 (*Conditions Precedent*) to the Conditions (as inserted into the Conditions pursuant to Clause 9.5);

“Floating Offshore Wind” means Offshore Wind that satisfies the floating offshore wind conditions set out in Regulation 27ZA of the Contracts for Difference (Allocation) Regulations 2014;“

Force Majeure” means any event or circumstance including;

- (A) any Change in Law (which expression , for the purposes of this definition, shall not include any Foreseeable Change in Law, and, in the period to the Start Date, shall include any change after the Agreement Date in the policy or guidance of any Competent Authority); and
- (B) any event or circumstance resulting from any action or omission by or of any CfD Settlement Services Provider),

provided that such event or circumstance:

- (i) is beyond the reasonable control of the FM Affected Party or, if relevant, its Representatives (in the case of the Generator and its Representatives, acting and having acted to a Reasonable and Prudent Standard);

² Drafting note: Drafting in the preceding set of square brackets is to be retained only if the Facility Generation Technology is Offshore Wind (including Floating Offshore Wind).

- (ii) could not reasonably have been avoided or overcome by the FM Affected Party or its Representative (as appropriate); and
- (iii) is not due to the FM Affected Party's fault or negligence (or that of its Representatives),

provided always that:

- (a) neither non-availability of funds nor the lack of funds shall ever constitute Force Majeure; and
- (b) no event or circumstance which has occurred before the FiT CfD Application Date of which, at or before the FiT CfD Application Date, the Generator or any of its Representatives either was aware, or (if it or they had made all due and careful enquiries and acted to a Reasonable and Prudent Standard) could be expected to have been aware, shall constitute a Force Majeure.

“Generator Metering Breach Notice” has the meaning given to that term in Condition 31.5 (as inserted pursuant to Clause 8);

“Grid Connection” means a connection between the Facility and the Total System;

“Grid Connection Agreement” means an offer in relation to a Grid Connection from a Licensed Distributor accepted and duly executed by the Generator or, where the Generator is not the owner of the Private Network associated with the Facility, duly executed by the Private Network Operator;

“Grid Connection Application” means (i) an application by a Generator to a Licensed Distributor for a Grid Connection; or (ii) an application by a Generator to a Private Network Operator to access a Grid Connection by way of a Private Network Use Agreement;

“Half-Hourly Metering Equipment” means the Metering Equipment which provides measurements on a half-hourly basis for the purposes of the CfD Settlement Activities;

“Hybrid Generator” means a Private Network Generator which has access to a Grid Connection and has a Market Supply Agreement with an Onsite Customer;

“Industry Documents” means all agreements, codes, standards and instruments regulating the generation, transmission, distribution, supply or trading of electricity in Great Britain, including the Grid Code, the SOTO Code, the BSC, the Code Subsidiary Documents, the CUSC, the Master Registration Agreement, any Distribution Code, any Distribution Connection and Use of System Agreement, any other connection or use of system agreement with a Transmission Licensee or Licensed Distributor, the MOF and the TSRs, and **“Industry Document”** shall be construed accordingly;

“Instation” means a computer based system which collects or receives metering data on a routine basis from selected Outstations;

“Intermittent Difference Amount” has the meaning given to that term in Condition 17 (as amended pursuant to Clause 4.5);

“Interrogation Unit” means a hand held unit (“**HHU**”) or a portable computer, which can enter Metering Equipment parameters, extract information from the Metering Equipment and store such information for later retrieval;

“Islanded Generator” means a Private Network Generator which has a Market Supply Agreement with an Onsite Customer but which does not have access to a Grid Connection;

“Islanded Generator Grid Connection Termination Event” has the meaning given to that term in Condition 30.3 (as inserted into the Conditions pursuant to Clause 6.3);

“Key Meter Technical Details” means those items set out in paragraph 6.3.2 of the MOF;

“Key Meter Technical Details Form” means the form identified as such in Appendix 1 of the MOF;

“Last Reported Output” has the meaning given in Condition 10.3(A) (as inserted into the Conditions pursuant to Clause 4.3);

“Last Reported Output Period” has the meaning given in Condition 10.3(A) (as inserted into the Conditions pursuant to Clause 4.3);

“Line Loss Factor” means, in relation to each Settlement Unit, the multiplier applicable to the Facility Voltage Class in relation to that Settlement Unit and used to adjust the Metered Volume to account for losses on a Distribution System, dependent on the Facility’s geographical location and as calculated on the basis of a methodology developed by the relevant Licensed Distributor (and approved in accordance with the BSC);

“Loss Adjusted Metered Output” means, in respect of a Settlement Unit, the Metered Volume in respect of that Settlement Unit, adjusted for:

- (A) the Line Loss Factor (or any new or substituted multiplier or factor which is in the nature of, or similar to, a Line Loss Factor) applicable to that Settlement Unit; and
- (B) any transmission loss multiplier (or any new or substituted multiplier which is in the nature of, or similar to, a transmission loss multiplier) applicable to that Settlement Unit which would have been allocated in accordance with the BSC were the Metered Volume to have been submitted to a BSC Company or a BSC Agent;

“Loss of Route to Market Grace Period” has the meaning given to that term in Condition 30.5 (as inserted into the Conditions pursuant to Clause 6.3);

“Loss of Route to Market Notice” has the meaning given to that term in Condition 30.4 (as inserted into the Conditions pursuant to Clause 6.3);

“Loss of Route to Market Termination Event” has the meaning given to that term in Condition 30.7 (as inserted into the Conditions pursuant to Clause 6.3);

“Main Meter” means the primary Meter that the Generator is required to calibrate, install, commission and maintain pursuant to and in accordance with the MOF and the TSRs to

measure Metered Volume (excluding, where the Facility is a Dual Scheme Facility, the Imported Input Electricity);

“Material Change” means a change to the Metering Equipment (including the replacement of any Meter or Measurement Transformer) or Communications Equipment other than a change by way of repair, modification or replacement of any component which is not a substantial part of the Metering System even where an enhanced or equivalent component is used for the repair, modification or replacement rather than an identical component;

“Measurement Quantity ID” means the set of electricity measurements required for Metered Volume (expressed in kWh) that must be supported by the Facility Metering Equipment in accordance with paragraph 2 of the TSRs;

“Measurement Transformer” means either a current transformer (“CT”) or a voltage transformer (“VT”) or a device carrying out both such functions, whose purpose is to enable Metering Equipment to operate at more convenient currents and/or voltages (as applicable) than are present on the circuit being measured;

“Meter” means a device (including any Main Meter or Check Meter) for measuring volumes of electricity;

“Meter Commissioning Test” means the Meter commissioning test described in paragraph 6 of the MOF;

“Meter Multiplier” means a multiplier which converts the stored values from the Outstation into MWh values;

“Meter Register” means a physical Meter reading displayed in kWh or MWh;

“Meter Serial Number” means, in relation to each Main Meter, the serial number for that Main Meter;

“Metered Volume” means, in relation to a Settlement Unit, the volume of electricity generated by the Facility in that Settlement Unit as measured by the Facility Metering Equipment in accordance with the MOF and the TSRs, less:

- (A) if the Facility is not a Dual Scheme Facility, the volume of input electricity, comprising parasitic and site load, used by the Facility in respect of that Settlement Unit; or
- (B) if the Facility is a Dual Scheme Facility, the volume of input electricity comprising parasitic load used by the Facility and the Imported Electricity Allowance in respect of that Settlement Unit (as determined in accordance with Condition 13 (*Baseload Dual Scheme Facilities*) or Condition 19 (*Intermittent Dual Scheme Facilities*) (as applicable)),

in each case, expressed in MWh;

“Metering Access Contact Information” means the Generator's contact information (or the contact information of its appointed representative) as notified to the CfD

Counterparty for the purposes of enabling the CfD Counterparty to exercise the Metering Access Right, and which must:

- (A) allow the Generator (or its appointed representative) to be contacted by the CfD Counterparty (and its appointed representatives) at any time during Working Hours on a Business Day without prior notice; and
- (B) enable the CfD Counterparty (and its appointed representatives) to obtain such access as they require within three hours of them first using the contact information for that purpose;

“Metering Access Right” has the meaning given to that term in Condition 31.16 (as inserted into the Conditions pursuant to Clause 8.1);

“Metering Audit” means an audit, check, examination, inspection, test or any verification conducted by the CfD Counterparty and/or its appointed representative in accordance with Condition 31.16 (as inserted into the Conditions pursuant to Clause 8) for the purposes of enabling and assisting the CfD Counterparty to assess compliance or non-compliance by the Generator with the Metering Compliance Obligations and the Electrical Schematic Obligation;

“Metering Breach Response Notice” has the meaning given to that term in Condition 31.3 (as inserted into the Conditions pursuant to Clause 8.1);

“Metering Breach Response Notice Period” has the meaning given to that term in Condition 31.3 (as inserted into the Conditions pursuant to Clause 8.1);

“Metering Compliance Obligation” has the meaning given to that term in Condition (as inserted into the Conditions pursuant to Clause 8.1);

“Metering Dispute” has the meaning given to that term in Condition 23.5 (as inserted into the Conditions pursuant to Clause 16.5);

“Metering Dispute Deadline” has the meaning given to that term in Clause 16.10(C);

“Metering Equipment” means Meters, Measurement Transformers, metering protection equipment (including alarms), circuitry, associated Communications Equipment, Outstations and wiring;

“Metering Remediation Plan” means a plan developed by the Generator (in accordance with the Reasonable and Prudent Standard), in substantially the form set out in Annex 8 (*Notices*), setting out appropriate milestones and actions to be taken in order to remedy a breach of a Metering Compliance Obligation, which is: (i) consistent with the Generator’s obligations pursuant to the MOF and the TSRs; and (ii) satisfactory to the CfD Counterparty (acting reasonably);

“Metering System” means a complete set of commissioned Metering Equipment installed to measure the volumes of input and output electricity at a particular location for the purposes of the CfD Settlement Activities;

“**MOF**” means the document entitled “Private Network Metering Operational Framework” set out in Annex 6 (*Private Network Metering Operational Framework*);

“**Onsite Customer**” means a customer of which the Generator is the supplier of electricity pursuant to a Market Supply Agreement and which is located on the same Private Network as the Generator;

“**Outstation**” means equipment which receives and stores metering data from a Meter for the purpose of transferring that metering data to the CfD Counterparty for the CfD Settlement Activities, and which may perform some processing before such transfer and may be one or more separate units or may be integral with the Meter;

“**Outstation Number of Channels**” means the total number of channels configured in the Outstation;

“**Outstation System**” means one or more Outstations linked to a single communications line;

“**Password**” means the password applicable to the relevant level of the Outstation, as set out in the TSRs for the Outstation;

“**Plant**” means fixed or movable items used in the generation, supply, distribution and/or transmission of electricity, other than Apparatus;

“**Private Network**” means a network for the distribution of electricity which is not operated by a Licensed Distributor;

“**Private Network DRP**” means the dispute resolution procedure set out in Clause 16.10;

“**Private Network Operator**” means, in relation to a Private Network, the owner of that Private Network;

“**Private Network Use Agreement**” means, where the Generator is not the Private Network Operator, an agreement between the Generator and the Private Network Operator which sets out the terms on which the Generator is able to access a Private Network belonging to the Private Network Operator, and, in particular:

- (A) specifies the capacity in relation to the Private Network that the Generator is able to use;
- (B) specifies the terms on which the Generator can use the Private Network to supply an Onsite Customer; and
- (C) in the case of a Hybrid Generator, specifies the terms on which the Generator can use the Private Network to obtain access to a Grid Connection;

“**Proving Test**” means the test described in paragraph 7 of the MOF;

“**Pulse Multiplier**” means the constant which has to be applied to the metering data from each Outstation in relation to a Settlement Unit to convert the values to MWh;

“**Rated Measuring Current**” means the capacity of the Meter to measure currents;

“**Route to Market**” means a Grid Connection or a Market Supply Agreement with an Onsite Customer;

“**Route to Market Remediation Notice**” has the meaning given to that term in Condition 30.5 (as inserted into the Conditions pursuant to Clause 6.3);

“**Total System**” means the Transmission System and each Distribution System; and

“**TSRs**” means the document entitled “Private Network Technical System Requirements” set out in Annex 7 (*Private Network Technical System Requirements*).

Definition of Private Network Generator

- 1.3 The Generator shall be deemed to be a “**Private Network Generator**” if:
- (A) it is exempt from the requirement to hold a licence for the generation of electricity pursuant to the Electricity (Class Exemptions from the Requirement for a License) Order 2001;
 - (B) the Facility generates electricity solely or partly for supply to a Private Network; and
 - (C) the Facility Metering Equipment is not, and is not required to be, registered in accordance with the BSC (except, where the Facility is a Dual Scheme Facility, in respect of the Boundary Point Metering System used to measure the Imported Input Electricity).

Interpretation

- 1.4 All references to “MSID” in the Conditions shall be deleted and replaced with the words “Meter Serial Number”.
- 1.5 For the purposes of the definition of “Metering System” and in the MOF and the TSRs, “**commission**” shall mean commission for the purposes of the MOF and TSRs and “**commissioned**” and other derivative terms shall be construed accordingly.
- 1.6 For the purposes of *[Clause 4.6 and in]³* the MOF and the TSRs, “**metering data**” shall mean data relating to the measurements which is required to calculate Metered Volume, as derived from the stored values of the Facility Metering Equipment.
- 1.7 Condition 1.10(B) of the Conditions shall be amended so that any reference to an Industry Document shall, where the relevant Industry Document is the TSRs, be deemed to be to the version of the TSRs current as at the date of this Private Network CfD Agreement (and not as amended, supplemented, restated, novated or replaced from time to time), provided that if there has been a Material Change, such a reference shall be to the version of the TSRs current as at the date of that Material Change.

³ Drafting note: Reference to be retained only if Clause 4.6 is retained.

2. AGREEMENT

The Generator

- 2.1 The Generator shall, as from the Agreement Date, comply with this Private Network CfD Agreement (including the Conditions) as the “**Generator**” and agrees that the Conditions are hereby incorporated into this Private Network CfD Agreement as if they were clauses of this Private Network CfD Agreement.

The CfD Counterparty

- 2.2 The CfD Counterparty shall, as from the Agreement Date, comply with this Private Network CfD Agreement (including the Conditions) as the “**CfD Counterparty**” and agrees that the Conditions are hereby incorporated into this Private Network CfD Agreement as if they were clauses of this Private Network CfD Agreement

Specific terms

- 2.3 [*The Parties have agreed to amend the Conditions as set out in Annex 2 (Modification Agreement).*⁴]
- 2.4 The Parties agree that, for the purposes of this Contract for Difference, the Conditions shall be amended, modified, supplemented or replaced in accordance with the terms of this Private Network CfD Agreement.

3. TERM

The “**Specified Expiry Date**” applicable to this Contract for Difference is: [*the 15th anniversary of the earlier of the Start Date and the last day of the Target Commissioning Window*].

4. METERED OUTPUT

Calculation of Metered Output

- 4.1 Condition [10.1(A)]/[18.1]⁵ shall be deleted and replaced as follows:

[“(A) (subject to Conditions 10.2 to 10.4) the Loss Adjusted Metered Output for such Settlement Unit as calculated by the CfD Counterparty using the Metered Volume provided by the Generator or its appointed representative for the purposes of the CfD Settlement Activities; multiplied by”];/

[“18.1. The CfD Counterparty shall calculate the Metered Output in respect of each Settlement Unit using the Metered Volume provided by the Generator or its appointed representative for the purposes of the CfD Settlement Activities. The “**Metered Output**” in respect of each Settlement Unit shall be (subject to

⁴ Drafting note: Clause to be retained only if specific amendments to any given Contract for Difference are agreed to be made pursuant to Part 3 of The Contract for Difference (Standard Terms) Regulations 2014 (as amended).

⁵ Drafting note: Drafting in relation to Condition 10 to be retained where technology is a Baseload Technology. Drafting in relation to Condition 18 to be retained where technology is an intermittent Technology. Delete as applicable.

Conditions 18.2 to 18.6) the Loss Adjusted Metered Output for such Settlement Unit as calculated by the CfD Counterparty.”]

4.2 Condition *[10.2]/[18.2]*⁶ of the Conditions shall be deleted and replaced with the following:

*[“10.2 If the CfD Counterparty has not received the Metered Volume for any Settlement Unit (an “**Estimated Output Settlement Unit**”) within a Billing Period (an “**Estimated Output Billing Period**”) on or prior to the Metered Output Cut-Off Time, the Loss Adjusted Metered Output for the Estimated Output Settlement Unit, as set out in the Billing Statement relating to such Estimated Output Billing Period (an “**Estimated Output Billing Statement**”), shall be calculated by the CfD Counterparty in accordance with Condition 10.3.”]; /*

*[“18.2 If the CfD Counterparty has not received the Metered Volume for any Settlement Unit (an “**Estimated Output Settlement Unit**”) within a Billing Period (an “**Estimated Output Billing Period**”) on or prior to the Metered Output Cut-Off Time, the Loss Adjusted Metered Output for the Estimated Output Settlement Unit, as set out in the Billing Statement relating to such Estimated Output Billing Period (an “**Estimated Output Billing Statement**”), shall be calculated by the CfD Counterparty in accordance with Condition 18.3.”].*

4.3 Condition *[10.3]/[18.3 to 18.5]*⁷ of the Conditions shall be deleted and replaced with the following:

*[“10.3 The estimated Loss Adjusted Metered Output for each Estimated Output Settlement Unit comprised within an Estimated Output Billing Period (the “**Estimated Metered Output**”) shall be calculated by the CfD Counterparty, at its discretion, on any one of the following bases:*

- (A) the Loss Adjusted Metered Output in the most recent Settlement Unit prior to the Estimated Output Settlement Unit for which the CfD Counterparty has received notification of the Metered Volume (such Metered Volume being the “**Last Reported Output**” and such Settlement Unit being the “**Last Reported Output Period**”);*
- (B) (if a Metering Audit has been conducted since the Last Reported Output Period) the Loss Adjusted Metered Output calculated by the CfD Counterparty using the Metered Volumes taken from any Meter readings obtained during the Metering Audit; or*
- (C) the Loss Adjusted Metered Output using Metered Volumes for the relevant Estimated Output Settlement Unit provided by the Generator (or its appointed representative) prior to the Metered Output Cut-Off Time and which the CfD Counterparty considers to be more accurate than the Last Reported Output.”]/*

⁶ Drafting note: Drafting in relation to Condition 10 to be retained where technology is a Baseload Technology. Drafting in relation to Condition 18 to be retained where technology is an intermittent Technology. Delete as applicable.

⁷ Drafting note: Drafting in relation to Condition 10 to be retained where technology is a Baseload Technology. Drafting in relation to Condition 18 to be retained where technology is an intermittent Technology. Delete as applicable.

[“18.3 Subject to Conditions 18.4 and 18.5, the estimated Loss Adjusted Metered Output for each Estimated Output Settlement Unit comprised within an Estimated Output Billing Period (the “**Estimated Metered Output**”) shall be calculated by the CfD Counterparty at its discretion on any one of the following bases:

- (A) the arithmetic mean of the Loss Adjusted Metered Output for the corresponding Settlement Units in each of the seven (7) Billing Periods immediately prior to the Estimated Output Billing Period for which the CfD Counterparty has received notification of the Metered Volumes (such Metered Volumes being the “**Last Reported Output**” and such Billing Period being the “**Last Reported Output Period**”);
- (B) (if a Metering Audit has been conducted since the Last Reported Output Period) the Loss Adjusted Metered Output calculated by the CfD Counterparty using the Metered Volumes taken from any Meter readings obtained during the Metering Audit; or
- (C) the Loss Adjusted Metered Output using Metered Volumes for the relevant Estimated Output Settlement Unit provided by the Generator (or its appointed representative) prior to the Metered Output Cut-Off Time and which the CfD Counterparty considers to be more accurate than the Last Reported Output.

18.4 If an Estimated Output Billing Period is:

- (A) a Long Clock Change Day, then the second (2nd) Settlement Unit in each of the Billing Periods specified in Condition 18.3(A) shall be repeated for the purposes of estimating the Loss Adjusted Metered Output during the additional hour in such Clock Change Day; or
- (B) a Short Clock Change Day, then the second (2nd) Settlement Unit in each of the Billing Periods specified in Condition 18.3(A) shall be ignored for the purposes of estimating the Loss Adjusted Metered Output during such Clock Change Day.

18.5 If any of the Billing Periods specified in Condition 18.3(A) is:

- (A) a Long Clock Change Day, then the second (2nd) Settlement Unit in such Billing Period shall be ignored for the purposes of estimating the Loss Adjusted Metered Output for the Estimated Output Billing Period; or
- (B) a Short Clock Change Day, then the second (2nd) Settlement Unit in such Billing Period shall be repeated for the purposes of estimating the Loss Adjusted Metered Output for the Estimated Output Billing Period.”]

4.4 Condition [10.4]/[18.6]⁸ of the Conditions shall be deleted and replaced with the following:

⁸ Drafting note: Drafting in relation to Condition 10 to be retained where technology is a Baseload Technology. Drafting in relation to Condition 18 to be retained where technology is an intermittent Technology. Delete as applicable.

[“10.4 If the Generator subsequently notifies the CfD Counterparty of the Metered Volume for an Estimated Output Settlement Unit:

- (A) the CfD Counterparty shall recalculate the Metered Output for such Settlement Unit using such Metered Volume; and*
- (B) if the calculation performed by the CfD Counterparty pursuant to Condition 10.4(A) results in a different Metered Output than that calculated by the CfD Counterparty in relation to the Estimated Output Settlement Unit and reflected in the relevant Estimated Output Billing Statement, then:*
 - (i) the recalculated Metered Output shall be used by the CfD Counterparty to recalculate:*
 - (a) the Baseload Difference Amount for the relevant Estimated Output Settlement Unit; and*
 - (b) the Aggregate Difference Amount for the Estimated Output Billing Period;*
 - (ii) any adjustment to the Aggregate Difference Amount for the Estimated Output Billing Period shall be treated as and will constitute a Reconciliation Amount; and*
 - (iii) such Reconciliation Amount shall be included as such in the Billing Statement which is next issued by the CfD Counterparty.”]*

[“18.6 If the Generator subsequently notifies the CfD Counterparty of the Metered Volume for an Estimated Output Settlement Unit:

- (A) the CfD Counterparty shall recalculate the Metered Output for such Settlement Unit using such Metered Volume; and*
- (B) if the calculation performed by the CfD Counterparty pursuant to Condition 18.6(A) results in a different Metered Output than that calculated by the CfD Counterparty in relation to the Estimated Output Settlement Unit and reflected in the relevant Estimated Output Billing Statement, then:*
 - (i) the recalculated Metered Output shall be used by the CfD Counterparty to recalculate:*
 - (a) the Intermittent Difference Amount for each relevant Estimated Output Settlement Unit; and*
 - (b) the Aggregate Difference Amount for the Estimated Output Billing Period;*

- (ii) *any adjustment to the Aggregate Difference Amount for the Estimated Output Billing Period shall be treated as and constitute a Reconciliation Amount; and*
- (iii) *such Reconciliation Amount shall be included as such in the Billing Statement which is next issued by the CfD Counterparty.”]*

4.5 In the definition of [*“Baseload Difference Amount” in Condition 9 (Definitions: Part 5A) of the Conditions*]/[*“Intermittent Difference Amount” in Condition 17 (Definitions: Part 5B)*]⁹ the definition of TLM_t shall be deleted and replaced with the following: *“is the transmission loss multiplier (or any new or substituted multiplier or factor which is the nature of, or similar to, a transmission loss multiplier, in Settlement Unit (t)) which would have been allocated in accordance with the BSC were the Metered Volume to have been submitted to a BSC Company or a BSC Agent;”*.

- (i) *[For the purposes of the CfD Settlement Activities then any metering data provided to the CfD Counterparty by the Generator on a half hourly basis shall be aggregated by the CfD Counterparty if and to the extent necessary to enable the calculation of the Metered Output on a Settlement Unit basis.]*¹⁰

5. GENERATION TECHNOLOGY TYPE

Facility Generation Technology

- 5.1 The Facility Generation Technology applicable to this Contract for Difference is [●]¹¹ [, *provided that for the purposes of paragraph (A) of the definition of Specific Change in Law or paragraphs (B) or (C) of the definition of Other Change in Law, Offshore Wind, Onshore Wind and Remote Island Wind may be deemed to be one Facility Generation Technology*].¹²
- 5.2 The Facility Generation Technology is a [*Baseload*]/[*Intermittent*]¹³ technology.

⁹ Drafting note: Drafting in relation to Condition 9 to be retained where technology is a Baseload Technology. Drafting in relation to Condition 17 to be retained where technology is an intermittent Technology. Delete as applicable.

¹⁰ Drafting note: Provision to be retained only where the Facility Generation Technology is an Intermittent Technology.

¹¹ Drafting note: This shall be the facility generation technology notified to the Delivery Body in the Generator's FiT CfD Application as the type of eligible generating station being one of the facility generation technologies in Table A of the CfD Standard Terms Notice issued on 25 November 2021 by the Secretary of State for Business, Energy and Industrial Strategy. Where the Generator's FiT CfD Application was made for Floating Offshore Wind as opposed to Offshore Wind generally, the words to insert shall be "*Floating Offshore Wind*".

¹² Drafting note: Proviso to be retained only if the Facility Generation Technology is Offshore Wind (including Floating Offshore Wind), Onshore Wind or Remote Island Wind.

¹³ Drafting note: Baseload to be retained for generation technologies identified as being baseload in Table B of the CfD Standard Terms Notice issued on 25 November 2021 by the Secretary of State for Business, Energy and Industrial Strategy. Intermittent to be retained for generation technologies identified as being intermittent in such Table B.

[Baseload Technology]/[Intermittent Technology]¹⁴

- 5.3 The Parts and Annexes to the Conditions referenced in Part [A]/[B]¹⁵ of Annex 3 (*Facility Generation Type*) shall apply to this Contract for Difference.

Renewable Qualifying Multiplier

- 5.4 The Renewable Qualifying Multiplier *[does not apply]/[applies]*¹⁶ to this Contract for Difference.
- 5.5 *[The “Assumed RQM” applicable to this Contract for Difference is [to be specified]*^{17, 18]}

CHP Qualifying Multiplier

The CHP Qualifying Multiplier *[does not apply]/[applies]*¹⁹ to this Contract for Difference.

ACT Efficiency Multiplier

- 5.5A The ACT Efficiency Multiplier *[does not apply]/[applies]* to this Contract for Difference.²⁰
- 5.5B *[The Assumed ACT Efficiency Multiplier applicable to this Contract for Difference is 1.]*²¹

Fuelling Criteria

- 5.6 For the purposes of this Contract for Difference, the **“Fuelling Criteria”** means the criteria specified in Annex 4 (*Fuelling Criteria*) in relation to the Facility Generation Technology. If Annex 4 (*Fuelling Criteria*) does not specify any Fuelling Criteria in relation to the Facility Generation Technology, such definition shall be deemed to be inapplicable to the Contract for Difference.
- 5.7 *[Paragraph 7 (Failure to comply with Fuelling Criteria) of Part E of Annex 7 (FMS arrangements, Sustainability Criteria, RQM Calculation Methodology and ACT Efficiency) to the Conditions shall, for the purposes of this Contract for Difference, be substituted with the following Condition:*

¹⁴ Drafting note: Baseload to be retained for generation technologies identified as being baseload in Table B of the CfD Standard Terms Notice issued on 25 November 2021 by the Secretary of State for Business, Energy and Industrial Strategy. Intermittent to be retained for generation technologies identified as being intermittent in such Table B.

¹⁵ Drafting note: Part A shall apply if the technology is Baseload, Part B if it is Intermittent. Delete as applicable.

¹⁶ Drafting note: This is to apply where it is specified to apply in Table C of the CfD Standard Terms Notice issued on 25 November 2021 by the Secretary of State for Business, Energy and Industrial Strategy.

¹⁷ Drafting note: The value will be that which is specified to apply in Table D of the CfD Standard Terms Notice issued on 25 November 2021 by the Secretary of State for Business, Energy and Industrial Strategy.

¹⁸ Drafting note: Clause to be retained and completed only if the Renewable Qualifying Multiplier applies to the Contract for Difference.

¹⁹ Drafting note: This is to apply where it is specified to apply in Table E of the CfD Standard Terms Notice issued on 25 November 2021 by the Secretary of State for Business, Energy and Industrial Strategy.

²⁰ The ACT Efficiency Multiplier will apply where the generation technology is Advanced Conversion Technology.

²¹ Drafting note: Clause to be retained and completed only if the ACT Efficiency Multiplier applies to the Contract for Difference.

“Subject to paragraph 5 (Deemed RQM: Strike Price below Market Reference Price), if the Generator fails to comply with paragraph (A) of the Fuelling Criteria in any RQM Calculation Month, then the CfD Counterparty may elect to calculate or recalculate the Renewable Qualifying Multiplier for that RQM Calculation Month on the basis that the Renewable Qualifying Multiplier may be deemed to be zero (0).”^{22]}

Sustainability Criteria

5.8 The Sustainability Criteria [*do*]/[*do not*]²³ apply to this Contract for Difference.

[Baseload]/[Intermittent] Dual Scheme Facility

5.9 The Facility is [*a Baseload*]/[*an Intermittent*] Dual Scheme Facility.^{24]}

Eligible Low Capacity Facility

5.10 The Facility [*is*]/[*is not*]²⁵ an Eligible Low Capacity Facility.

6. GENERATOR UNDERTAKINGS: GENERAL AND ROUTE TO MARKET

6.1 Condition 30.1 of the Conditions shall be amended by the addition of the following new Conditions after Condition 30.1(G):

“30.1(H)Route to Market: With effect from the Start Date, the Generator shall ensure that it has a Route to Market, provided that the Generator shall not be deemed to be in breach of this Condition 30.1(H) in circumstances in which:

- (i) it ceases to have a Route to Market but has given the CfD Counterparty a Loss of Route to Market Notice in accordance with Condition 30.4; and*
- (ii) on or prior to the expiry of the Loss of Route to Market Grace Period, it gives the CfD Counterparty a Route to Market Remediation Notice (and an accompanying Directors’ Certificate) in accordance with Conditions 30.5(A)(i), 30.5(B) and 30.6.*

30.1(I) Grid Connection: If the Generator specified in the FiT CfD Application that it is, or will be, an Islanded Generator, it shall not make a Grid Connection Application,

²² Drafting note: Clause to be retained if the Facility Generation Technology is Advanced Conversion Technology Anaerobic Digestion Landfill Gas or Sewage Gas.

²³ Drafting note: This is to apply where it is specified to apply in Table F of the CfD Standard Terms Notice issued on 25 November 2021 by the Secretary of State for Business, Energy and Industrial Strategy.

²⁴ Drafting note: The Facility is a Baseload Dual Scheme Facility if: (i) it forms part of a Generating Station which includes one (1) or more other Generating Units which are not part of the Facility; (ii) the Facility Metering Equipment does not determine the Imported Input Electricity consumed exclusively by the Facility; and (iii) Part A of Annex 3 (Facility Generation Type) applies. The Facility is an Intermittent Dual Scheme Facility if: (i) it forms part of a Generating Station which includes one (1) or more other Generating Units which are not part of the Facility; (ii) the Facility Metering Equipment does not determine the Imported Input Electricity consumed exclusively by the Facility; and (iii) Part B of Annex 3 (Facility Generation Type) applies. Delete this paragraph if the Facility is not a Baseload Dual Scheme Facility or an Intermittent Dual Scheme Facility, as applicable.

²⁵ Drafting note: Clause to be retained only if the Facility is an Eligible Low Capacity Facility. The Facility is an Eligible Low Capacity Facility if (i) it has an Initial Installed Capacity Estimate not greater than (30) MW; and (ii) its Facility Generation Technology is Offshore Wind (including Floating Offshore Wind), Onshore Wind, Tidal Range, Tidal Stream or Wave.

or otherwise obtain access to a Grid Connection (including by way of a Private Network Use Agreement) other than where it has ceased to have a Route to Market.

30.1(J) *Private Network Generator: The Generator shall at all times ensure that it remains a Private Network Generator.*"

6.2 Condition 30.2 of the Conditions shall be amended so that the words "or 30.1(J)" are inserted after "Condition 30.1(F)".

6.3 The following shall be added as new Conditions after Condition 30.2:

“Islanded Generator Grid Connection

30.3 *If the Generator breaches its obligations under Condition 30.1(I), an Islanded Generator Grid Connection Termination Event shall be deemed to have occurred.*

Cessation of Route to Market

30.4 *If the Generator is an Islanded Generator and it ceases to have a Route to Market it shall notify the CfD Counterparty immediately (a “**Loss of Route to Market Notice**”). A Loss of Route to Market Notice shall:*

- (A) *specify the date on which the Generator ceased to have a Route to Market; and*
- (B) *be accompanied by such Supporting Information as is reasonably necessary to evidence that the Generator has ceased to have a Route to Market.*

30.5 *If a Generator has given the CfD Counterparty a Loss of Route to Market Notice, it shall give a notice to the CfD Counterparty (a “**Route to Market Remediation Notice**”) on or prior to the date falling 18 months after the date on which it ceased to have a Route to Market (the “**Loss of Route to Market Grace Period**”). A Route to Market Remediation Notice shall:*

- (A) *specify that the Generator either:*
 - (i) *has entered into a Market Supply Agreement with an Onsite Customer or a Grid Connection Agreement (and, if required in order to supply the relevant Onsite Customer or to access the relevant Grid Connection, has entered into a Private Network Use Agreement); or*
 - (ii) *has not entered into a Market Supply Agreement with an Onsite Customer or a Grid Connection Agreement (or, if required in order to supply the relevant Onsite Customer or to access the relevant Grid Connection, has not entered into a Private Network Use Agreement); and*
- (B) *in the case of a Route to Market Remediation Notice falling within paragraph (A)(i) above, the Generator shall include:*

- (i) *a copy of the Market Supply Agreement with an Onsite Customer or the Grid Connection Agreement (and, where relevant, the Private Network Use Agreement), in each case duly executed by the parties to it and certified as being correct and up-to-date by a director or company secretary of the Generator (or, in the case of a Grid Connection Agreement only, where the counterparty is the Private Network Operator and not the Generator, by a director or company secretary of the Private Network Operator); and*
- (ii) *(if the Generator (or, where applicable, the Private Network Operator) has entered into a Grid Connection Agreement) such Supporting Information as is reasonably necessary to evidence that all sums payable upon entry in the Grid Connection Agreement have been paid.*

30.6 *Any Route to Market Remediation Notice shall be accompanied by a Directors' Certificate in relation to the information contained in, and enclosed with, the Route to Market Remediation Notice.*

30.7 *If the Generator:*

- (A) *does not give a Route to Market Remediation Notice to the CfD Counterparty on or prior to the expiry of the Loss of Route to Market Grace Period;*
- (B) *gives a Route to Market Remediation Notice falling within paragraph (A)(ii) above;*
- (C) *does not include the documentation and Supporting Information required to be provided with a Route to Market Remediation Notice falling within Condition 30.5(A)(i); or*
- (D) *does not provide the Directors' Certificate referred to in Condition 30.6,*

then a Loss of Route to Market Termination Event will be deemed to have occurred.

30.8 *There shall be no extension of the Term as a result of the application of Conditions 30.5 and 30.6."*

7. TERMINATION EVENTS: ROUTE TO MARKET

7.1 Condition 53.1 of the Conditions shall be amended by the addition of the following new Conditions after Condition 53.1(H):

"53.1(I) Route to Market: *A Loss of Route to Market Termination Event.*

53.1(J) Islanded Grid Connection: *An Islanded Generator Grid Connection Termination Event."*

8. GENERATOR UNDERTAKINGS: METERING

8.1 Condition 31 of the Conditions shall be deleted and replaced with the following:

“Undertakings: Facility Metering Equipment

31.1 *With effect from the Start Date, the Generator undertakes to the CfD Counterparty:*

- (A) *to comply at all times with the MOF and the TSRs;*
- (B) *where the Facility is a Dual Scheme Facility, to ensure that at all times the Boundary Point Metering System meets all applicable rules and standards provided for in the BSC;*
- (C) *to ensure that at all times:*
 - (i) *the Facility Metering Equipment accurately records the Metered Volume; and*
 - (ii) *where the Facility is a Dual Scheme Facility, the Boundary Point Metering System accurately records all Imported Input Electricity in relation to the Generating Station;*
- (D) *Without prejudice to Conditions 31.1(H)(ii) and (I), to ensure that at all times the Facility Metering Equipment measures the input and output electricity referred to in Condition 31.1(C) separately from any other input and output electricity;*
- (E) *to investigate any fault or issue with the Facility Metering Equipment of which it is notified by the CfD Counterparty or otherwise required to investigate pursuant to the MOF and the TSRs;*
- (F) *to provide to the CfD Counterparty (or procure that the CfD Counterparty is provided with) the Metered Volume in relation to each Settlement Unit by the Metered Output Cut-Off Time;*
- (G) *if the Facility is a Dual Scheme Facility, to provide to the CfD Counterparty (or procure that the CfD Counterparty is provided with) the Imported Input Electricity in relation to each Settlement Unit by the Metered Output Cut-Off Time;*
- (H) *to ensure at all times that no Electricity Storage Facility shall be used by or otherwise associated with the Facility, unless:*
 - (i) *the electricity produced by or from such Electricity Storage Facility is measured by metering equipment which is not used by or shared or associated with the Facility Metering Equipment; or*
 - (ii) *subject to Condition 31.1(I), the electricity produced by or from such Electricity Storage Facility is measured by metering equipment which is used by or shared or associated with the*

Facility Metering Equipment and the CfD Counterparty has issued a notice certifying that it is satisfied that the arrangement and installation of the Facility Metering Equipment is such that the Generator is able to comply with the Condition 31.1(I); and

- (I) *to ensure at all times that any Electricity Storage Facility, where the electricity produced by or from such Electricity Storage Facility is measured by metering equipment which is used by or shared or associated with the Facility Metering Equipment, shall only store electricity generated by the Generating Unit(s) of the Facility using the Facility Generation Technology and shall not store electricity imported from any other source.*

*(each, a "Metering Compliance Obligation" and together the "**Metering Compliance Obligations**").*

Notification of Metering Compliance Obligation breach by CfD Counterparty

31.2 *The CfD Counterparty may at any time give a notice to the Generator if it considers that the Generator is in breach of a Metering Compliance Obligation (a "**CfD Counterparty Metering Breach Notice**"). A CfD Counterparty Metering Breach Notice shall:*

- (A) *specify which Metering Compliance Obligation the CfD Counterparty considers that the Generator has breached; and*
- (B) *be accompanied by such Supporting Information as the CfD Counterparty considers necessary to evidence the breach of the Metering Compliance Obligation.*

Response to notification of Metering Compliance Obligation breach

31.3 *Subject to Condition 31.7, no later than ten (10) Business Days after receipt of a CfD Counterparty Metering Breach Notice (a "**Metering Breach Response Notice Period**"), the Generator shall investigate whether it is in breach of the relevant Metering Compliance Obligation and give a notice to the CfD Counterparty (a "**Metering Breach Response Notice**"). A Metering Breach Response Notice shall state that either:*

- (A) *the Generator accepts that there has been a breach of the Metering Compliance Obligation (and, in such case, the notice should include confirmation of the date from which the Generator accepts that there has been a breach of the relevant Metering Compliance Obligation); or*
- (B) *the Generator does not accept that there has been a breach of the Metering Compliance Obligation.*

31.4 *If:*

- (A) *the Generator submits a Metering Breach Response Notice in accordance with Condition 31.3(A), the provisions of Condition 31.5 shall apply; or*
- (B) *the Generator fails to submit a Metering Breach Response Notice within the Metering Breach Response Notice Period or submits a Metering Breach Response Notice in accordance with Condition 31.3(B), the Expert Determination Procedure shall apply to determine whether there has been a breach of the Metering Compliance Obligation and if the Expert Determination Procedure applied pursuant to this Condition 31.4(B) determines that:*
 - (i) *there has not been a breach of the Metering Compliance Obligation, then neither Party shall be required to take any further steps in relation to the CfD Counterparty Metering Breach Notice; or*
 - (ii) *there has been a breach of the Metering Compliance Obligation, the provisions of Condition 31.5 shall apply.*

Notification of Metering Compliance Obligation breach by Generator

- 31.5 *The Generator shall notify the CfD Counterparty as soon as reasonably practicable after it becomes aware that it is in breach of a Metering Compliance Obligation specifying the breach that has occurred (a “**Generator Metering Breach Notice**”). If the Generator gives a Generator Metering Breach Notice, Condition 31.7 shall apply.*
- 31.6 *Where the Generator is required under the MOF to re-test an item of Facility Metering Equipment in relation to a Metering Commissioning Test or a Proving Test and the item fails the re-test, such a failure shall constitute a breach of the Metering Compliance Obligations and the Generator must give the CfD Counterparty a Generator Metering Breach Notice in accordance with Condition 31.5.*

Resolution of Metering Compliance Obligation breach

- 31.7 *If this Condition 31.7 applies:*
- (A) *the Generator shall provide a copy of a Metering Remediation Plan to the CfD Counterparty:*
 - (i) *(if the CfD Counterparty has given the Generator a CfD Counterparty Metering Breach Notice) no later than fifteen (15) Business Days after the later of: (a) the expiry of the Metering Breach Response Notice Period; and (b) the date on which an Expert makes a determination in accordance with Condition 31.4(B)(ii) (as applicable); or*

- (ii) *(if the Generator has given the CfD Counterparty a Generator Metering Breach Notice) no later than fifteen (15) Business Days after such notice has been given;*
- (B) *except where the Facility is a Dual Scheme Facility and the breach relates to the Boundary Point Metering System:*
- (i) *as soon as reasonably practicable after the date referred to in paragraph (A) above and in any event not later than sixty (60) Business Days after the CfD Counterparty has approved the Metering Remediation Plan, the Generator shall implement the Metering Remediation Plan and remedy the breach of the Metering Compliance Obligation;*
 - (ii) *the Generator shall give a notice to the CfD Counterparty confirming the fulfilment of its obligations pursuant to Condition 31.7(B)(i) no later than five (5) Business Days after remedying the breach and in any case not later than sixty (60) Business Days after the CfD Counterparty has approved the Metering Remediation Plan (a “**Generator Metering Remediation Notice**”) together with such Supporting Information as is reasonably necessary to evidence that the breach has been remedied and a Directors’ Certificate confirming the accuracy of both the Generator Metering Remediation Notice and the Supporting Information; and*
 - (iii) *the CfD Counterparty shall have the right to request further tests be conducted pursuant to the MOF and TSRs; and*
- (c) *if the Facility is a Dual Scheme Facility and the breach relates to the Boundary Point Metering System:*
- (i) *as soon as reasonably practicable after the date referred to in paragraph (A) above and in any event no later than sixty (60) Business Days after a BSC Company has approved the Metering Remediation Plan, the Generator shall:*
 - (a) *implement the Metering Remediation Plan and remedy the breach of the Metering Compliance Obligation; and*
 - (b) *provide to the CfD Counterparty written confirmation from the relevant BSC Company that the breach of the Metering Compliance Obligation has been remedied to the satisfaction of such relevant BSC Company; and*
 - (ii) *the Generator shall give a notice to the CfD Counterparty confirming the fulfilment of its obligations pursuant to Condition 31.7(C)(i) no later than five (5) Business Days after remedying the breach and in any case not later than sixty (60) Business Days after a BSC Company has approved the Metering Remediation Plan (a “**Generator BPMS Metering Remediation**”*

Notice) together with such Supporting Information as is reasonably necessary to evidence that the breach has been remedied.

- 31.8 The CfD Counterparty may, by notice to the Generator no later than twenty (20) Business Days after receipt of a Generator Metering Remediation Notice or a Generator BPMS Metering Remediation Notice, require the Generator to provide such Supporting Information in relation to that Generator Metering Remediation Notice or Generator BPMS Metering Remediation Notice (a “**Generator Metering Remediation Notice Information Request**”) as the CfD Counterparty reasonably requests.
- 31.9 If the CfD Counterparty gives a Generator Metering Remediation Notice Information Request, the Generator shall, no later than twenty (20) Business Days, or such longer period as is specified by the CfD Counterparty, after receipt of the request, prepare and deliver such further Supporting Information to the CfD Counterparty.
- 31.10 If the Generator receives a CfD Counterparty Metering Breach Notice specifying that the CfD Counterparty considers that the Generator has breached the Metering Compliance Obligation set out in Condition 31.1(F) or 31.1(G), Conditions [10.2 and 10.3]/[18.2 and 18.3]²⁶ (Estimates of Loss Adjusted Metered Output) shall apply instead of Conditions 31.3 to 31.9.

Failure to remedy Metering Compliance Obligation breach

- 31.11 If the Generator has not complied with its obligations under Condition 31.7 or 31.9, then a Technical Compliance Termination Event will be deemed to have occurred.

Undertakings: electrical schematic

- 31.12 If there is a Material Change to the Facility Metering Equipment then the Generator shall:
- (A) notify the CfD Counterparty as soon as reasonably practicable and in any event no later than two (2) Business Days after the Material Change occurs, setting out details of the Material Change that has been effected (an “**Electrical Schematic Obligation Notice**”);
 - (B) provide an updated version of the electrical schematic diagram referred to in paragraph 2.1(D) of Part B of Schedule 1 (Conditions Precedent) as soon as reasonably practicable and in any event no later than ten (10) Business Days after the Material Change occurs,
- (the “**Electrical Schematic Obligation**”).

²⁶ Drafting note: Drafting in relation to Condition 10 to be retained where technology is a Baseload Technology. Drafting in relation to Condition 18 to be retained where technology is an intermittent Technology. Delete as applicable.

31.13 Any:

- (A) *Electrical Schematic Obligation Notice shall be accompanied by a Directors' Certificate in relation to the details of the Material Change so notified; and*
- (B) *copy of the electrical schematic diagram provided pursuant to Condition 31.12(B) shall be accompanied by a Directors' Certificate in relation to the electrical schematic diagram (including its date and the version number).*

Failure to comply with Electrical Schematic Obligation

- 31.14 *If the Generator is in breach of the Electrical Schematic Obligation, the CfD Counterparty may elect to suspend payment of any Net Payable Amounts which would otherwise be payable by the CfD Counterparty to the Generator in any period during which the Generator is in breach of the Electrical Schematic Obligation, provided that, prior to effecting any such suspension, the CfD Counterparty shall notify the Generator of: (i) its intention to suspend payment of any Net Payable Amounts; and (ii) the date from which it proposes to effect such suspension.*
- 31.15 *If the Generator subsequently complies with its Electrical Schematic Obligation, then the CfD Counterparty shall pay any amounts to the Generator which would have been payable but for the operation of Condition 31.14. No Compensatory Interest or Default Interest shall be payable in respect of any amount payable pursuant to this Condition 31.15.*

Undertakings: Access to and testing of meters

- 31.16 *With effect from the Start Date, the Generator shall grant (or, in relation to the Boundary Point Metering System, shall procure that the Registrant grants) the CfD Counterparty (and any and all persons nominated by the CfD Counterparty and considered by the CfD Counterparty to be suitably qualified) access without prior notice by the CfD Counterparty to the Facility, the Facility Metering Equipment and to such plant, property or assets owned, occupied or controlled by the Generator (or the Registrant in relation to the Boundary Point Metering System) and to which the Generator (or the Registrant in relation to the Boundary Point Metering System) can lawfully grant access as may be reasonably necessary for the CfD Counterparty to conduct a Metering Audit (the "**Metering Access Right**"). The Metering Access Right shall only be exercised on Business Days during Working Hours.*
- 31.17 *If the CfD Counterparty or its appointed representative is unable to gain immediate access on attempting to exercise the Metering Access Right, the CfD Counterparty shall use the Metering Access Contact Information to seek to gain such access. If the CfD Counterparty or its appointed representative is not able to gain access within three (3) hours of first using the Metering Access Contact information, then the Generator shall be in breach of its obligation to permit the CfD Counterparty to exercise the Metering Access Right.*

31.18 *The CfD Counterparty shall (and shall procure that any suitably qualified persons nominated by it in accordance with Condition 31.16 to exercise the Metering Access Right shall):*

- (A) *take or refrain from taking all such other action as may be reasonably required by the Generator in order to comply with health and safety rules relating to the Facility; and*
- (B) *obtain each authorisation, licence, accreditation, permit, consent, certificate, resolution, clearance, exemption, order confirmation, permission or other approval of or from a Competent Authority necessary for it to exercise the Metering Access Right.*

Failure to provide Metering Access Right

31.19 *If the Generator is in breach of its obligation to permit the CfD Counterparty (or any person determined by the CfD Counterparty to be suitably-qualified) to exercise the Metering Access Right, the CfD Counterparty may elect to suspend payment of any Net Payable Amounts which would otherwise be payable by the CfD Counterparty to the Generator in any period during which the Generator is in breach of such obligation, provided that, prior to effecting any such suspension, the CfD Counterparty shall notify the Generator of: (i) its intention to suspend payment of any Net Payable Amounts; and (ii) the date from which it proposes to effect such suspension.*

31.20 *If the Generator subsequently complies with its obligation to permit the CfD Counterparty to exercise the Metering Access Right, then the CfD Counterparty shall pay any amounts to the Generator which would have been payable but for the operation of Condition 31.19. No Compensatory Interest or Default Interest shall be payable in respect of any amount payable pursuant to this Condition 31.20.*

31.21 *If the Generator:*

- (A) *fails to comply with its obligations under Conditions 31.16 and 31.17; and*
- (B) *has not permitted the CfD Counterparty to exercise its Metering Access Right within ten (10) Business Days of the date on which the CfD Counterparty or its appointed representative first sought to exercise the Metering Access Right,*

then a Metering Access Termination Event will be deemed to have occurred.

Metering Access Right costs

31.22 *If, pursuant to or as a result of the exercise of the Metering Access Right, it is agreed or determined that there has been a breach of a Metering Compliance Obligation, the Generator shall promptly on demand from time to time, indemnify the CfD Counterparty, and keep the CfD Counterparty fully and effectively indemnified, against any and all out-of-pocket costs properly incurred by the CfD Counterparty in exercising the Metering Access Right.”*

Notices

- 8.2 For the purposes of this Private Network CfD Agreement, the “**CfD Counterparty Metering Breach Notice**” shall mean the “**Metering Breach Notice**” set out in Annex 8 (*Pro forma notices*) of the Conditions.
- 8.3 For the purposes of the Private Network CfD Agreement, the “**Electrical Schematic Obligation Notice**” shall be that set out in Annex 8 (*Notices*) of this Private Network CfD Agreement, and not that set out in Annex 8 (*Pro forma notices*) of the Conditions.

Information Undertakings

- 8.4 Condition 32.1 shall be amended by deleting Condition 32.1(G) and replacing it with the following:

“(G) notification of:

- (i) any Market Supply Agreement with an Onsite Customer being entered into or becoming effective or being novated, assigned or otherwise transferred to a different counterparty;
- (ii) the termination of any Market Supply Agreement with an Onsite Customer; and
- (iii) in relation to an Islanded Generator, a Grid Connection Application being made, or a Grid Connection Agreement or a Private Network Use Agreement being entered into or becoming effective,

in each case not less than five (5) Business Days prior to the same occurring or, in the case of (ii), if the termination of any Market Supply Agreement with an Onsite Customer is not effected by the Generator, as soon as reasonably practicable thereafter; and”.

9. CONDITIONS PRECEDENT AND MILESTONE

Interpretation

- 9.1 The “**Initial Target Commissioning Window**” applicable to this Contract for Difference shall be [●]²⁷, such period commencing on [●]²⁸.
- 9.2 The “**Target Commissioning Date**” applicable to this Contract for Difference shall be [●]²⁹.

²⁷ Drafting note: This is to be equal to the Target Commissioning Window period applicable to the Facility Generation Technology listed in Table G of the CfD Standard Terms Notice issued on 25 November 2021 by the Secretary of State for Business, Energy and Industrial Strategy.

²⁸ Drafting note: This shall be the date notified to the Delivery Body in the Generator’s FiT CfD Application as the start of the Target Commissioning Window.

²⁹ Drafting note: This shall be the date notified to the Delivery Body in the Generator’s FiT CfD Application as its “Target Commissioning Date” and will be a date falling within the Initial Target Commissioning Window.

- 9.3 The “**Longstop Period**” applicable to this Contract for Difference shall be [●]³⁰ or such longer period that results from an extension in accordance with the definition of “**Longstop Date**”.

Operational Conditions Precedent

- 9.4 Paragraphs 2.1(C), (D) and (E) of Part B (*Further Conditions Precedent*) of Schedule 1 (*Conditions Precedent*) to the Conditions shall be deleted and replaced with the following:

“(C) *evidence, in form and content satisfactory to the CfD Counterparty, acting reasonably, that the Generator is complying in full with the Metering Compliance Obligations, which shall include:*

- (i) *a manufacturer’s certificate given by the manufacturer of each Meter and Measurement Transformer confirming that they have been calibrated, meet the accuracy and measurement range requirements set out in the TSRs and conform with relevant product standards appropriate to the class index of the Meters and Measurement Transformers;*
- (ii) *a Directors' Certificate confirming that each of the Meters and the Measurement Transformers has been calibrated, installed, commissioned, proved and tested in accordance with the manufacturer's instructions;*
- (iii) *a Key Meter Technical Details Form; and*
- (iv) *a report from a suitably qualified person, approved by the CfD Counterparty, confirming that the Facility Metering Equipment has satisfied all the applicable tests required to be completed prior to the Start Date pursuant to the MOF and the TSRs;*
- (v) *a report from a suitably qualified person, approved by the CfD Counterparty, confirming that no Electricity Storage Facility is being used by or otherwise associated with the Facility, unless:*
 - (a) *the electricity produced by or from such Electricity Storage Facility is being measured by metering equipment which is not used by or shared or associated with the Facility Metering Equipment; or*
 - (b) *subject to Condition 31.1(I), where the electricity produced by or from such Electricity Storage Facility is being measured by metering equipment which is used by or shared or associated with the Facility Metering Equipment, the CfD Counterparty has issued a notice certifying that it is satisfied that the arrangement*

³⁰ Drafting note: This is to be equal to the Longstop Period applicable to the Facility Generation Technology listed in Table H of the CfD Standard Terms Notice issued on 25 November 2021 by the Secretary of State for Business, Energy and Industrial Strategy.

and installation of the Facility Metering Equipment is such that the Generator is able to comply with the Condition 31.1(I); and

(vi) a report from a suitably qualified person, approved by the CfD Counterparty confirming that where electricity produced by or from an Electricity Storage Facility is being measured by metering equipment which is being used by or shared or associated with the Facility Metering Equipment, such Electricity Storage Facility is only storing electricity generated by the Generating Unit(s) of the Facility using the Facility Generation Technology and does not store electricity imported from any other source.

(D) a date and time stamped copy of the electrical schematic diagram, certified as being correct and up-to-date by a director of the Generator and showing the locations of the Facility Metering Equipment associated with all assets comprised within the Facility (including: details of the type of metering and Communications Equipment installed in compliance with the Metering Compliance Obligation; and the Meter Serial Number for each of the Meters); and

(E) evidence, in form and content satisfactory to the CfD Counterparty, acting reasonably, that all Communications Equipment relating to Facility Metering Equipment is satisfactorily installed, commissioned, configured, operational, maintained, tested and are fully compliant with the applicable TSRs.”

9.5 Paragraph 2.5 of Part B (*Further Conditions Precedent*) of Schedule 1 (*Conditions Precedent*) to the Conditions shall be deleted and replaced with the following additional Operational Condition Precedent applicable to this Contract for Difference:

“2.5 Delivery to the CfD Counterparty of the following:

(A) the Metering Access Contact Information;

(B) confirmation (in form and content satisfactory to the CfD Counterparty, acting reasonably) of the voltage class for the Facility as at the Start Date for the purposes of calculating the applicable Line Loss Factor (together with a Directors’ Certificate certifying that such voltage class is correct);

(C) evidence (in form and content satisfactory to the CfD Counterparty, acting reasonably) that the Generator has a Route to Market, including:

(i) a copy of each Market Supply Agreement with an Onsite Customer to which the Generator is a party, duly executed by the parties to it and certified as being a true and complete copy of the original by a director or company secretary of the Generator;

(ii) (if the Generator is a Hybrid Generator) a copy of a Grid Connection Agreement duly executed by the parties to it and certified as being a true and complete copy of the original by a director or company secretary of the Generator (together with Supporting Information satisfactory to the CfD Counterparty to

evidence that all sums payable upon entry in the Grid Connection Agreement have been paid);

- (iii) (if the Generator is not the Private Network Operator) a copy of the Private Network Use Agreement duly executed by the parties to it and certified as being a true and complete copy of the original by a director or company secretary of the Generator; and
 - (iv) a Directors' Certificate confirming that the Generator has a Route to Market; and
- (D) where the Generator is a Hybrid Generator, written confirmation from the relevant Licensed Distributor that the Distribution Code compliance process for connection to and export to the Distribution System has been satisfied."

Milestone

- 9.6 The "**Initial Milestone Delivery Date**" applicable to this Contract for Difference shall be eighteen (18) months after the Agreement Date.
- 9.7 The "**Total Project Pre-Commissioning Costs**" applicable to this Contract for Difference shall be £[●]³¹ per MW of the Installed Capacity Estimate.
- 9.8 The "**Project Commitments**" applicable to this Contract for Difference shall be the requirements provided for in:
- (A) Part A of Annex 5 (*Project Commitments*); and
 - (B) the section of Part B of Annex 5 (*Project Commitments*) which is expressed to apply to the Facility Generation Technology.
- 9.9 [For the purpose of Condition 4.1, the Project shall exclude the assets comprised or to be comprised within the Offshore Transmission System of the Facility.]³²
- 9.10 [In relation to the Facility's [turbines]/[generation engines]:
- (A) [in addition to the requirements set out in Condition 4.1 of the Conditions, a Milestone Requirement Notice must include the size or anticipated estimated size (expressed in MW) of each of the Facility's [turbines]/[generation engines]; and
 - (B) the Generator shall, acting to a Reasonable and Prudent Standard, notify the CfD Counterparty of the size or anticipated estimated size (expressed in MW) of each of the Facility's [turbines]/[generation engines] if any change to the size of any [turbine]/[generation engine] is proposed to be made. Such notification shall be

³¹ Drafting note: This is to be equal to the Total Project Pre-Commissioning Costs applicable to the Facility Generation Technology listed in Table I of the CfD Standard Terms Notice issued on 25 November 2021 by the Secretary of State for Business, Energy and Industrial Strategy.

³² Drafting note: Clause to be retained only if the Facility Generation Technology is Offshore Wind (including Floating Offshore Wind).

*given promptly and no later than ten (10) Business Days after the Generator effects or decides to effect the relevant change.]*³³

10. NOT USED

11. INSTALLED CAPACITY ESTIMATE AND REQUIRED INSTALLED CAPACITY

11.1 The “**Initial Installed Capacity Estimate**” applicable to this Contract for Difference is: [●]³⁴MW.

11.2 The “**Required Installed Capacity**” applicable to this Contract for Difference is: [the lower of (a)]³⁵ [*eighty-five per cent. (85%) of the Installed Capacity Estimate*]³⁶ / [*ninety- five per cent. (95%) of the Installed Capacity Estimate*]³⁷ [or (b) *the Installed Capacity Estimate less the size (expressed in MW) of one of the Facility's [turbines]/[generation engines]*]³⁸.

12. CHANGES IN LAW

12.1 The “**Assumed Load Factor**” applicable to this Contract for Difference is [●]³⁹.

12.2 The “**Post-Tax Real Discount Rate**” applicable to this Contract for Difference is [●]⁴⁰.

12.3 The definition of “**Specific Change in Law**” shall be amended by the addition of a new paragraph (AA) and by the amendment of paragraph (D) as follows:

“(AA) *generators which are Private Network Generators, and not to generators which are not Private Network Generators;*

(D) *the holding of shares in companies, the membership of partnerships, limited partnerships or limited liability partnerships, the participation in joint ventures (whether or not incorporated) or the holding of any other economic interest in an undertaking whose main business is the development, construction, operation*

³³ Drafting note: Clause, and reference to turbines, to be refined if the Facility Generation Technology is Onshore Wind, Offshore Wind (including Floating Offshore Wind) or Remote Island Wind. Clause, and reference to generation engines, to be retained if the Facility Generation Technology is Tidal Range, Tidal Stream or Wave.

³⁴ Drafting note: This shall be either (a) the capacity notified by the Delivery Body in the Generator's FiT CfD Application as the capacity in megawatts, or (b) if the Allocation Round in which the Generator is participating requires them to submit a sealed bid, then the capacity for which successful allocation has taken place under the Allocation Round.

³⁵ Drafting note: Drafting to be retained only if the Facility is an Eligible Low Capacity Facility.

³⁶ Drafting note: Drafting to be retained only if the Facility Generation Technology is Offshore Wind (but not Floating Offshore Wind).

³⁷ Drafting note: Drafting to be retained only if the Facility Generation Technology is either Floating Offshore Wind or not Offshore Wind.

³⁸ Drafting note: Clause, and reference to turbines, to be refined if the Facility Generation Technology is Onshore Wind, Offshore Wind (including Floating Offshore Wind) or Remote Island Wind. Clause, and reference to generation engines, to be retained if the Facility Generation Technology is Tidal Range, Tidal Stream or Wave.

³⁹ Drafting note: This is to be equal to the “Assumed Load Factor” applicable to the Facility Generation Technology listed in Table J of the CfD Standard Terms Notice issued on 25 November 2021 by the Secretary of State for Business, Energy and Industrial Strategy.

⁴⁰ Drafting note: This is to be equal to the “Post-Tax Real Discount Rate” applicable to the Facility Generation Technology listed in Table K of the CfD Standard Terms Notice issued on 25 November 2021 by the Secretary of State for Business, Energy and Industrial Strategy.

and maintenance of generating facilities referred to in paragraph (A), (AA), (B) or (C) and not other generating facilities;”

13. PAYMENT CALCULATIONS: STRIKE PRICE

- 13.1 The “**Base Year**” applicable to this Contract for Difference is 2012.
- 13.2 The “**Initial Strike Price**” applicable to this Contract for Difference is £[●] per MWh⁴¹.

14. BALANCING SYSTEM (BSUOS/RCRC) AND TLM(D)

Part 10 (*Balancing System (BSUoS/RCRC) and TLM(D)*) of the Conditions does not apply to this Contract for Difference.

15. CURTAILMENT

- 15.1 Part 11 (*Curtailment*) of the Conditions applies to this Contract for Difference if and for so long as the Generator is a Hybrid Generator.
- 15.2 Part 11 (*Curtailment*) of the Conditions does not apply to this Contract for Difference if and for so long as the Generator is an Islanded Generator.

16. PRIVATE NETWORK METERING DISPUTE

- 16.1 Clauses 16.5 to 16.10 shall apply in relation to Metering Disputes other than to the extent that any Metering Dispute relates to the Boundary Point Metering System.
- 16.2 To the extent that a Metering Dispute relates to the Boundary Point Metering System, it shall be resolved in accordance with the Conditions without the amendments set out in this Clause 16.
- 16.3 Where a Metering Dispute relates to both the Boundary Point Metering System and the rest of the Facility Metering Equipment, Clauses 16.5 to 16.10 shall apply to all parts of that Metering Dispute other than that part which relates to the Boundary Point Metering System.
- 16.4 If there is a conflict between the determination of the disputes process in relation to the Boundary Point Metering System and the determination of the disputes process in relation to the rest of the Facility Metering Equipment, then to the extent of the conflict, the determination in relation to the dispute about the Boundary Point Metering System shall prevail.
- 16.5 Subject to Clauses 16.1 to 16.4, Condition 23.5 of the Conditions shall be deleted and replaced with the following:
- “23.5 If a dispute or part of a dispute pursuant to Condition 23.3 relates to the calculation of the Loss Adjusted Metered Output in respect of a Settlement Unit (a “**Metering Dispute**”):*

⁴¹ Drafting note: The Initial Strike Price will be provided by the Delivery Body following the Allocation Round.

- (A) *such Metering Dispute shall be resolved in accordance with the Private Network DRP;*
- (B) *the Parties shall continue to comply with their obligations under the Contract for Difference notwithstanding such Metering Dispute;*
- (C) *the final determination of the Metering Dispute in accordance with Condition 23.5(A) shall be binding on the Parties; and*
- (D) *neither Party shall dispute or attempt to dispute a final determination made in accordance with Condition 23.5(A).*

If the Facility is a Dual Scheme Facility, the reference in this Condition 23.5 to any dispute relating to “Loss Adjusted Metered Output” shall include any dispute relating to the calculation of the Imported Input Electricity used by the Generating Station in any Settlement Unit but shall exclude any dispute relating to any other component used in the calculation or recalculation of Imported Electricity Allowance.”

- 16.6 Subject to Clause 16.1, Condition 23.6 of the Conditions shall be deleted and replaced with the following:

“23.6 Any Metering Dispute must be brought by the Party before the Metering Dispute Deadline set out in the Private Network DRP.”

- 16.7 Subject to Clause 16.1, Condition 23.7 of the Conditions shall be deleted and replaced with the following:

“23.7 The Generator shall inform the CfD Counterparty as soon as reasonably practicable after the Generator becomes aware of any fact, matter or circumstance which will or is reasonably likely to give rise to a Metering Dispute, where the resolution of such Metering Dispute will or may impact the calculation of the Loss Adjusted Metered Output for the purposes of the Contract for Difference.”

- 16.8 Subject to Clause 16.1, Condition 63 (*Metering Disputes*) of the Conditions shall be deleted and replaced with the following:

“62.1 Metering Disputes shall be resolved solely in accordance with the Private Network DRP pursuant to Conditions 23.5 to 23.7.

62.2 Notwithstanding any Metering Dispute, the Parties shall continue to comply with all of their respective obligations under the Contract for Difference.”

- 16.9 Subject to Clause 16.1, each instance of the words “the provisions of the BSC” in Conditions 72.4(C) and 72.10(C) of the Conditions shall be deleted and replaced with the words “the Private Network DRP”.

Private Network DRP

- 16.10 Subject to Clause 16.1, Metering Disputes shall be resolved in accordance with the Dispute Resolution Procedure, save that:

- (A) Conditions 57.3(D) and 57.3(G) (*Outline of Dispute Resolution Procedure*), 60 (*Arbitration Procedure*) and 61 (*Consolidation of Connected Disputes*) of the Conditions shall not apply to Metering Disputes;
- (B) the following Conditions shall be amended for the purposes of Metering Disputes:
- (i) Condition 57.4(B) shall be deleted and replaced as follows:

“(B) (subject to Condition 57.6) either party may refer the Dispute for determination by an Expert in accordance with the Expert Determination Procedure.”;
 - (ii) the words “*or the Arbitration Procedure*” and “*and 60.2*” shall be omitted from Condition 57.7;
 - (iii) the words “*or an Arbitration Procedure*” shall be omitted from Condition 57.8(C);
 - (iv) Condition 58.1(B) shall be deleted and replaced as follows:

“(B) are unable to resolve the Dispute within the Resolution Period, either party may refer the Dispute for determination by an Expert in accordance with the Expert Determination Procedure;”;
 - (v) Condition 58.2(A) shall be deleted and replaced as follows:

“(A) either party may refer the Dispute for determination by an Expert in accordance with the Expert Determination Procedure;”;
 - (vi) the words “*nor the Arbitration Procedure*” shall be omitted from Condition 58.3; and
 - (vii) the words “*if either: (i) the Parties have agreed in writing that a Dispute is amenable to determination by an Expert pursuant to Condition 58.1(B) or 58.2(A); or (ii) the Contract for Difference expressly provides for the relevant Dispute to be determined by an Expert*” shall be omitted from Condition 59.1; and
- (C) for a Party to this Contract for Difference to bring a Metering Dispute, the following criteria must be met:
- (i) a Dispute Notice must have been given by the Metering Dispute Deadline in relation to all Settlement Units to which the Metering Dispute relates;
 - (ii) the “**Metering Dispute Deadline**” shall be the date which is twenty (20) months after the Billing Period in which the disputed Settlement Unit occurred or, if earlier, the date of the last Metering Audit.

17. PRO FORMA NOTICES

Where this Private Network CfD Agreement permits, or requires, either Party to give a notice to the other Party and the form of such notice is not set out in Annex 8 (*Pro forma*

notices), such notice shall be in substantially the form set out in the relevant annex to this Private Network CfD Agreement. The foregoing: (i) shall be without prejudice to the requirement for the relevant notice to include such content as may be prescribed by the relevant Clause; and (ii) shall apply only if the form of the notice in respect of the relevant Clause is contained in an annex to this Private Network CfD Agreement.

18. NOTICES

18.1 The address and email address of each Party for any notice to be given under this Contract for Difference, and the department or officer (if any) for whose attention the notice is to be made, is:

(A) in the case of the Generator:

Address:	
Email address:	
For the attention of:	

(B) in the case of the CfD Counterparty:

Address:	
Email address:	
For the attention of:	

19. AGENT FOR SERVICE OF PROCESS

*[Condition 87 (Agent for service of process) shall not apply to this Contract for Difference and there shall be no Service Agent.]/[Condition 93 (Agent for service of process) shall apply to this Contract for Difference and the Service Agent shall be [●] of [●].]*⁴²

20. DISAPPLICATION OF CONDITIONS

20.1 In addition to those Conditions specified above, the following Conditions shall not apply to this Contract for Difference:

(A) other than to the extent it applies to the Imported Input Electricity, Condition 22.5(A) (*Calculation of Reconciliation Amounts*); and

⁴² Drafting note: Delete as applicable. This shall be the agent notified to the Delivery Body in the Generator's FiT CfD Application as its agent for service of process, where the Applicant is not based in England/Wales.

- (B) other than to the extent it applies to the Imported Input Electricity, Condition 22.6(A) (*Calculation of Compensatory Interest Amount*).

Annex 1
(Description of the Facility)

The Facility is the [NAME OF PROJECT], falling within the area delineated by the following grid references:

Corner Point ID	Latitude	Longitude
Northerly corner	[•]	[•]
Easterly corner	[•]	[•]
Southerly corner	[•]	[•]
Westerly corner	[•]	[•]

[Drafting note: Description of the Facility to be populated using information provided in the [FiT CfD Application] and to include the unique geographical coordinates of the Facility.]

**Annex 2
(Modification Agreement)**

Annex 3
(Facility Generation Type)

Part A
(Baseload Technologies)

1. The following definition shall apply to this Contract for Difference:

“**Settlement Unit**” means each half hour period in a day divided into half hour-long periods starting at 00:00 on such day.
2. The following Parts and Annexes of the Conditions shall apply to this Contract for Difference:
 - (A) Part 5A (*Payment calculations: Baseload Technologies*); and
 - (B) Annex 4 (*BMRP*).

Part B
(Intermittent Technologies)

1. The following definition shall apply to this Contract for Difference:

“**Settlement Unit**” means each hour period in a day divided into hour-long periods starting at 00:00 on such day.

2. The following Parts and Annexes of the Conditions shall apply to this Contract for Difference:

(A) Part 5B (*Payment calculations: Intermittent Technologies*); and

(B) Annex 5 (*IMRP*).

Annex 4 (Fuelling Criteria)

1. DEFINITIONS AND INTERPRETATION

Definitions

1.1 For the purposes of this Annex 4 (*Fuelling Criteria*):

“Advanced Fuels” means a gaseous or liquid fuel which is produced directly or indirectly from the Gasification or the Pyrolysis of: (i) Waste; or (ii) Biomass, provided that, in the case only of a gaseous fuel, such fuel must have a gross calorific value (when measured at 25 degrees Celsius and 0.1 megapascals at the inlet to the Combustion Chamber) which is at least 2 megajoules per cubic metre;

“Biomass” means material, other than Fossil Fuel or peat, which is, or is derived directly or indirectly from, plant matter, animal matter, fungi, algae or bacteria (and includes any such material contained in Waste);

“Excluded Biomass” means: (i) sewage; and (ii) material in a landfill;

“Fossil Fuel” means coal, substances produced directly or indirectly from coal, lignite, natural gas, crude liquid petroleum or petrol products;

“Gasification” means the substoichiometric oxidation or steam reformation of a substance to produce a gaseous mixture containing two or more of the following: (i) oxides of carbon; (ii) methane; and (iii) hydrogen;

“Permitted Ancillary Activities” means the cleansing of other fuels from the Facility’s combustion system prior to heating the combustion system or Synthesis Chamber to its normal temperature, the heating of the Facility’s combustion system to its normal operating temperature or the maintenance of that temperature, the ignition of fuels of low or variable calorific value, emission control, standby generation or the testing of standby generation capacity, corrosion control or fouling reduction;

“Pyrolysis” means the thermal degradation of a substance in the absence of any oxidising agent, which does not form part of the substance itself, to produce char and gas and/or liquid; and

“Waste” means any substance or object which the holder discards or intends or is required to discard; substances that have been intentionally modified or contaminated to meet that definition are not covered by this definition.

Interpretation

1.2 Where, in this Annex 4 (*Fuelling Criteria*) the **“Permitted Ancillary Activity Exception”** is expressed to apply, the relevant Fuelling Criterion (or Fuelling Criteria) which apply to the Facility Generation Technology shall not be breached solely by virtue of Fossil Fuels being used for Permitted Ancillary Activities if the Energy Content of all Fossil Fuels used by the Facility for such Permitted Ancillary Activities does not exceed ten per cent. (10%)

of the Energy Content of all fuels used by the Facility whether to generate electricity or for Permitted Ancillary Activities.

- 1.3 Any assessment as to whether the Fuelling Criteria are met by the Facility shall be determined by reference to the entirety of an RQM Calculation Month.

2. ADVANCED CONVERSION TECHNOLOGY

- (A) Subject to paragraph (B), the Facility generates electricity using solely Advanced Fuels.
- (B) The Permitted Ancillary Activity Exception applies.
- (C) No Fossil Fuel is used at the Facility for the express purpose of it being used as a fuel (other than to undertake Permitted Ancillary Activities), unless it forms part of Waste from which the fuel is produced.

3. ANAEROBIC DIGESTION

- (A) Subject to paragraph (B), the Facility generates electricity solely from gas formed during the anaerobic digestion of Biomass (other than Excluded Biomass).
- (B) The Permitted Ancillary Activity Exception applies.
- (C) No Fossil Fuel is used at the Facility for the express purpose of it being used as a fuel (other than to undertake Permitted Ancillary Activities), unless it forms part of Waste from which the fuel is produced.

4. NOT USED

5. DEDICATED BIOMASS WITH CHP

- (A) Subject to paragraph (B), the Facility generates electricity solely from fuel the Energy Content of which is at least 90 per cent. (90%) solid Biomass.
- (B) The Permitted Ancillary Activity Exception applies.
- (C) No Fossil Fuel is used at the Facility for the express purpose of it being used as a fuel (other than to undertake Permitted Ancillary Activities).

6. ENERGY FROM WASTE WITH CHP

- (A) The Facility:
 - (i) (subject to paragraph (B)) generates electricity solely from Waste, Biomass or a combination thereof; and
 - (ii) only uses Biomass, Waste or a combination thereof in respect of which the Energy Content constituting Fossil Fuel (excluding any Fossil Fuel used to undertake Permitted Ancillary Activities) as a percentage of all fuels used by the Facility, is more than ten per cent. (10%).

- (B) The Permitted Ancillary Activity Exception applies.
- (C) No Fossil Fuel is used at the Facility for the express purpose of it being used as a fuel (other than to undertake Permitted Ancillary Activities), unless it forms part of Waste from which the fuel is produced.

7. LANDFILL GAS

- (A) Subject to paragraph (B), the Facility generates electricity solely from gas formed by the digestion of material in a landfill.
- (B) The Permitted Ancillary Activity Exception applies.
- (C) No Fossil Fuel is used at the Facility for the express purpose of it being used as a fuel (other than to undertake Permitted Ancillary Activities), unless it forms part of Waste from which the gas is produced.

8. SEWAGE GAS

- (A) Subject to paragraph (B), the Facility generates electricity solely from gas formed by the anaerobic digestion of sewage (including sewage which has been treated or processed).
- (B) The Permitted Ancillary Activity Exception applies.
- (C) No Fossil Fuel is used at the Facility for the express purpose of it being used as a fuel (other than to undertake Permitted Ancillary Activities), unless it forms part of Waste from which the gas is produced.

Annex 5
(Project Commitments)

Part A: General Project Commitments

Delivery to the CfD Counterparty of the following:

- (A) a copy of a resolution of the Generator's board of directors (or an equivalent management committee or body) to:
 - (i) undertake the Project;
 - (ii) approve the total financial commitments required to commission the Project (the "**Total Project Spend**");
 - (iii) approve a timetable for undertaking the Project which demonstrates that the Facility can reasonably be expected to be commissioned no later than the Longstop Date;

- (B) a Directors' Certificate certifying that:
 - (i) the Generator has, or will have, sufficient financial resources to meet the Total Project Spend;
 - (ii) any contract entered into and provided as Supporting Information pursuant to the Milestone Requirements Notice, in the reasonable opinion of the Generator by reference to the facts and circumstances then existing, is:
 - (a) legal, valid and binding; and
 - (b) entered into with one or more counterparties who are each able to perform their obligations under such contract;
 - (iii) the Generator has a leasehold or freehold interest in the site where the Facility is based (the "**Facility Site**") or a contract to obtain the same;
 - (iv) the Facility Site is not subject to any covenants, restrictions, agreements, planning obligations, estate contracts, options, rights of way or other encumbrances which materially inhibit the use of the Facility Site for the purposes of the Project;
 - (v) there are available to the Facility Site such rights, easements and services as are necessary to undertake the Project and operate the Facility;
 - (vi) the Generator has identified all necessary consents and planning permissions to undertake the Project (the "**Necessary Consents**"); and
 - (vii) there is a credible strategy in place to obtain the Necessary Consents and the Necessary Consents are not subject to any condition for which there does not exist a plan to satisfy that condition, such that the

Generator is not aware of any necessary consents and planning permissions which cannot be obtained or complied with,

((iii) to (vii), together the “**Facility Requirements**”);

- (C) Supporting Information evidencing (i) that the Generator has, or will have, sufficient financial resources to meet the Total Project Spend and (ii) the Facility Requirements.

Part B: Technology Specific Project Commitments

1. ADVANCED CONVERSION TECHNOLOGY

Delivery to the CfD Counterparty of Supporting Information evidencing any one of the following:

- (A) Entry by the Generator into an engineering, procurement and construction contract for the Facility, providing for the supply and installation of the Material Equipment.
- (B) Entry by the Generator into an agreement for the supply of the Material Equipment.
- (C) Entry by the Generator into: (i) a framework agreement for the supply of the Material Equipment; and (ii) a binding purchase order for the Material Equipment.

For the purpose of this section of Part B, the following definition shall apply to this Contract for Difference:

“**Material Equipment**” means such equipment, which, acting in accordance with a Reasonable and Prudent Standard, the Generator could reasonably be expected to have ordered and/or concluded a supply agreement in respect of in accordance with the Target Commissioning Date, and in any event, such equipment shall include the gasifier or the pyrolyser.

2. NOT USED

3. ANAEROBIC DIGESTION

Delivery to the CfD Counterparty of Supporting Information evidencing any one of the following:

- (A) Entry by the Generator into an engineering, procurement and construction contract for the Facility providing for the supply and installation of the Material Equipment.
- (B) Entry by the Generator into an agreement for the supply of the Material Equipment.
- (C) Entry by the Generator into: (i) a framework agreement for the supply of the Material Equipment; and (ii) a binding purchase order for the Material Equipment.

For the purpose of this section of Part B, the following definition shall apply to this Contract for Difference:

“Material Equipment” means such equipment, which, acting in accordance with a Reasonable and Prudent Standard, the Generator could reasonably be expected to have ordered and/or concluded a supply agreement in respect of in accordance with the Target Commissioning Date, and in any event, such equipment shall include the anaerobic digester.

4. NOT USED

5. NOT USED

6. DEDICATED BIOMASS WITH CHP

Delivery to the CfD Counterparty of Supporting Information evidencing paragraph (A), paragraph (B) and any one of paragraphs (C), (D) and (E).

- (A) (i) Entry by the Generator into a framework contract for the supply of heat; or (ii) if the Generator proposes to use heat on-site, completion of a detailed feasibility study for the Project, including an energy consumption profile.
- (B) Entry by the Generator into a framework contract for the supply of sufficient sustainable biomass feedstock for the Facility to operate at the Installed Capacity Estimate.
- (C) Entry by the Generator into an engineering, procurement and construction contract for the Facility, providing for the supply and installation of the Material Equipment.
- (D) Entry by the Generator into an agreement for the supply of the Material Equipment.
- (E) Entry by the Generator into: (i) a framework agreement for the supply of the Material Equipment; and (ii) a binding purchase order for the Material Equipment.

For the purpose of this section of Part B, the following definition shall apply to this Contract for Difference:

“Material Equipment” means such equipment, which, acting in accordance with a Reasonable and Prudent Standard, the Generator could reasonably be expected to have ordered and/or concluded a supply agreement in respect of in accordance with the Target Commissioning Date, and in any event, such equipment shall include the furnace and boiler island.

7. ENERGY FROM WASTE WITH CHP

Delivery to the CfD Counterparty of Supporting Information evidencing paragraph (A), paragraph (B) and any one of paragraphs (C), (D) and (E).

- (A) (i) Entry by the Generator into a framework contract for the supply of heat; or (ii) if the Generator proposes to use heat on-site, completion of a detailed feasibility study of the Project, including an energy consumption profile.
- (B) (i) Entry by the Generator into a contract for the disposal of waste generated by the Facility in the course of its energy generating activities; or (ii) entry by the Generator into contracts for the provision of Solid Recovered Fuel (“**SRF**”) or Municipal Solid Waste (“**MSW**”) to the Facility.
- (C) Entry by the Generator into an engineering, procurement and construction contract for the Facility, providing for the supply and installation of the Material Equipment.
- (D) Entry by the Generator into an agreement for the supply of the Material Equipment.
- (E) Entry by the Generator into: (i) a framework agreement for the supply of the Material Equipment; and (ii) a binding purchase order for the Material Equipment.

For the purpose of this section of Part B, the following definition shall apply to this Contract for Difference:

“**Material Equipment**” means such equipment, which, acting in accordance with a Reasonable and Prudent Standard, the Generator could reasonably be expected to have ordered and/or concluded a supply agreement in respect of in accordance with the Target Commissioning Date, and in any event, such equipment shall include the furnace and boiler island.

8. **GEOTHERMAL**

Delivery to the CfD Counterparty of Supporting Information evidencing entry by the Generator into a contract to drill the Facility’s first well.

9. **NOT USED**

10. **HYDROELECTRICITY**

Delivery to the CfD Counterparty of Supporting Information evidencing any one of the following:

- (A) Entry by the Generator into an engineering, procurement and construction contract for the Facility, providing for the civil works to be undertaken in respect of the Material Equipment.
- (B) Entry by the Generator into a civil works contract to be undertaken in respect of the Material Equipment.
- (C) Entry by the Generator into: (i) a framework agreement for the civil works to be undertaken in respect of the Material Equipment; and (ii) a binding purchase order for the Material Equipment.

For the purpose of this section of Part B, the following definition shall apply to this Contract for Difference:

“Material Equipment” means such equipment, which, acting in accordance with a Reasonable and Prudent Standard, the Generator could reasonably be expected to have ordered and/or concluded a supply agreement in respect of in accordance with the Target Commissioning Date, and in any event, such equipment shall include the major scheme components.

11. LANDFILL GAS

Delivery to the CfD Counterparty of Supporting Information evidencing any one of the following:

- (A) Entry by the Generator into an engineering, procurement and construction contract for the Facility, providing for the supply and installation of the Material Equipment.
- (B) Entry by the Generator into an agreement for the supply of the Material Equipment.
- (C) Entry by the Generator into: (i) a framework agreement for the supply of the Material Equipment; and (ii) a binding purchase order for the Material Equipment.

For the purpose of this section of Part B, the following definition shall apply to this Contract for Difference:

“Material Equipment” means such equipment, which, acting in accordance with a Reasonable and Prudent Standard, the Generator could reasonably be expected to have ordered and/or concluded a supply agreement in respect of in accordance with the Target Commissioning Date, and in any event, such equipment shall include the electricity generating engines.

12. OFFSHORE WIND (INCLUDING FLOATING OFFSHORE WIND)

Delivery to the CfD Counterparty of Supporting Information evidencing any one of the following:

- (A) Entry by the Generator into an engineering, procurement and construction contract for the Facility, providing for the supply and installation of the Material Equipment.
- (B) Entry by the Generator into an agreement for the supply of the Material Equipment.
- (C) Entry by the Generator into: (i) a framework agreement for the supply of the Material Equipment; and (ii) a binding purchase order for the Material Equipment.

For the purpose of this section of Part B, the following definition shall apply to this Contract for Difference:

“Material Equipment” means such equipment, which, acting in accordance with a Reasonable and Prudent Standard, the Generator could reasonably be expected to have ordered and/or concluded a supply agreement in respect of in accordance with the Target Commissioning Date, and in any event, such equipment shall include wind turbines.

13. ONSHORE WIND

Delivery to the CfD Counterparty of Supporting Information evidencing any one of the following:

- (A) Entry by the Generator into an engineering, procurement and construction contract for the Facility, providing for the supply and installation of the Material Equipment.
- (B) Entry by the Generator into an agreement for the supply of the Material Equipment.
- (C) Entry by the Generator into: (i) a framework agreement for the supply of the Material Equipment; and (ii) a binding purchase order for the Material Equipment.

For the purpose of this section of Part B, the following definition shall apply to this Contract for Difference:

“Material Equipment” means such equipment, which, acting in accordance with a Reasonable and Prudent Standard, the Generator could reasonably be expected to have ordered and/or concluded a supply agreement in respect of in accordance with the Target Commissioning Date, and in any event, such equipment shall include wind turbines.

13A REMOTE ISLAND WIND

Delivery to the CfD Counterparty of Supporting Information evidencing any one of the following:

- (D) Entry by the Generator into an engineering, procurement and construction contract for the Facility, providing for the supply and installation of the Material Equipment.
- (E) Entry by the Generator into an agreement for the supply of the Material Equipment.
- (F) Entry by the Generator into: (i) a framework agreement for the supply of the Material Equipment; and (ii) a binding purchase order for the Material Equipment.

For the purpose of this section of Part B, the following definition shall apply to this Contract for Difference:

"Material Equipment" means such equipment, which, acting in accordance with a Reasonable and Prudent Standard, the Generator could reasonably be expected to have ordered and/or concluded a supply agreement in respect of in accordance with the Target Commissioning Date, and in any event, such equipment shall include wind turbines.

14. SEWAGE GAS

Delivery to the CfD Counterparty of Supporting Information evidencing any of the following:

- (A) Entry by the Generator into an engineering, procurement and construction contract for the Facility, providing for the supply and installation of the Material Equipment.
- (B) Entry by the Generator into an agreement for the supply of the Material Equipment.
- (C) Entry by the Generator into: (i) a framework agreement for the supply of the Material Equipment; and (ii) a binding purchase order for the Material Equipment.

For the purpose of this section of Part B, the following definition shall apply to this Contract for Difference:

“Material Equipment” means such equipment, which, acting in accordance with a Reasonable and Prudent Standard, the Generator could reasonably be expected to have ordered and/or concluded a supply agreement in respect of in accordance with the Target Commissioning Date, and in any event, such equipment shall include the electricity generating engines.

15. SOLAR PHOTOVOLTAIC

Delivery to the CfD Counterparty of Supporting Information evidencing any of the following:

- (A) Entry by the Generator into an engineering, procurement and construction contract for the Facility, providing for the supply and installation of the Material Equipment.
- (B) Entry by the Generator into an agreement for the supply of the Material Equipment.
- (C) Entry by the Generator into: (i) a framework agreement for the supply of the Material Equipment; and (ii) a binding purchase order for the Material Equipment.

For the purpose of this section of Part B, the following definition shall apply to this Contract for Difference:

“Material Equipment” means such equipment, which, acting in accordance with a Reasonable and Prudent Standard, the Generator could reasonably be expected to have ordered and/or concluded a supply agreement in respect of in accordance with the Target Commissioning Date, and in any event, such equipment shall include the photovoltaic panels.

16. TIDAL RANGE

Delivery to the CfD Counterparty of Supporting Information evidencing any of the following:

- (A) Entry by the Generator into an engineering, procurement and construction contract for the Facility, providing for the civil works to be undertaken in respect of the Material Equipment.
- (B) Entry by the Generator into a civil works contract to be undertaken in respect of the Material Equipment.
- (C) Entry by the Generator into: (i) a framework agreement for the civil works to be undertaken in respect of the Material Equipment; and (ii) a binding purchase order for the Material Equipment.

For the purpose of this section of Part B, the following definition shall apply to this Contract for Difference:

“Material Equipment” means such equipment, which, acting in accordance with a Reasonable and Prudent Standard, the Generator could reasonably be expected to have ordered and/or concluded a supply agreement in respect of in accordance with the Target Commissioning Date, and in any event, such equipment shall include the major scheme components.

17. TIDAL STREAM

Delivery to the CfD Counterparty of Supporting Information evidencing any of the following:

- (A) Entry by the Generator into an engineering, procurement and construction contract for the Facility, providing for the supply and installation of the Material Equipment.
- (B) Entry by the Generator into an agreement for the supply of the Material Equipment.
- (C) Entry by the Generator into: (i) a framework agreement for the supply of the Material Equipment; and (ii) a binding purchase order for the Material Equipment.

For the purpose of this section of Part B, the following definition shall apply to this Contract for Difference:

“Material Equipment” means such equipment, which, acting in accordance with a Reasonable and Prudent Standard, the Generator could reasonably be expected to have ordered and/or concluded a supply agreement in respect of in accordance with the Target Commissioning Date, and in any event, such equipment shall include the turbines.

18. WAVE

Delivery to the CfD Counterparty of Supporting Information evidencing any of the following:

- (A) Entry by the Generator into an engineering, procurement and construction contract for the Facility, providing for the supply and installation of the Material Equipment.

- (B) Entry by the Generator into an agreement for the supply of the Material Equipment.
- (C) Entry by the Generator into: (i) a framework agreement for the supply of the Material Equipment; and (ii) a binding purchase order for the Material Equipment.

For the purpose of this section of Part B, the following definition shall apply to this Contract for Difference:

“Material Equipment” means such equipment, which, acting in accordance with a Reasonable and Prudent Standard, the Generator could reasonably be expected to have ordered and/or concluded a supply agreement in respect of in accordance with the Target Commissioning Date, and in any event, such equipment shall include the wave energy converter or generation engines.

Annex 6
(Private Network Metering Operational Framework)

CONTENTS

1.	Introduction	56
2	Interpretation	56
3	Responsibility of Generator for Metering Equipment	56
4	Installation	57
5	Calibration	58
6	Commissioning	61
7	Proving	63
8	Sealing	67
9	Replacement	67
10	Third Party Meter Operator	67
11	Metering Data	68
12	Metering Checks	68
13	Validation of Metering Data	70
14	Information and records	70
	Appendix 1 Metering Records and Forms	72

1. INTRODUCTION

Metered Volume shall be measured and recorded through Metering Equipment calibrated, installed, commissioned, proved, operated, maintained, tested and otherwise provided for as set out in this MOF.

2. INTERPRETATION

In this MOF:

- (A) in relation to any Metering System, references to requirements under the TSRs shall be construed as requirements in relation to all of the Metering Equipment comprised or required to be comprised in that Metering System;
- (B) references to a Metering System include a Metering System which is to comprise Metering Equipment which a third party is or will be required to calibrate, install, commission, prove, operate, maintain or test;
- (C) references to Metering Equipment in the context of a Metering System or the Generator are to all of the Metering Equipment which is or is to be comprised in such Metering System (except that references to Metering Equipment shall not include references to Metering Equipment which comprises a Boundary Point Metering System, and references to a Metering System shall not include a Boundary Point Metering System);
- (D) where the Facility is a Dual Scheme Facility, references to Metered Volume shall not include Imported Input Electricity; and
- (E) “**BD**” shall mean “**Business Days**”.

3. RESPONSIBILITY OF GENERATOR FOR METERING EQUIPMENT

3.1 The Generator must ensure that:

- (A) all Facility Metering Equipment meets or exceeds the specifications set out in the TSRs;
- (B) the Facility Metering Equipment, including each Main Meter, Check Meter and Measurement Transformer, is calibrated, installed, commissioned, proved, operated, maintained and tested in such a way as to enable the CfD Counterparty to measure Metered Volume accurately and calculate the payments due under the Contract for Difference accordingly;
- (C) the Facility Metering Equipment is kept in good working order to the extent necessary to allow the correct registration, recording and submission of the metering data;
- (D) all Facility Metering Equipment is calibrated, installed, commissioned, proved and sealed in accordance with paragraphs 4 to 8 of this MOF and paragraphs 3 and 4 of the TSRs prior to the Start Date;
- (E) for each Main Meter there is a corresponding Check Meter;

- (F) neither the Main Meter nor the Check Meter is calibrated, commissioned or proved without the other Meter being so calibrated, commissioned or proved; and
 - (G) each Meter is appropriately labelled, where applicable, as to whether it relates to input electricity, output electricity or both.
- 3.2 The Metering Equipment to be installed:
- (A) must be Half-Hourly Metering Equipment; and
 - (B) must comply with Schedule 7 of the EA 1989.
- 3.3 The Generator may with the prior consent of the CfD Counterparty transfer to any person, or enter into an arrangement whereby any person is to perform any or all of its obligations under this MOF, provided that:
- (A) the CfD Counterparty (acting reasonably) must be satisfied that such a person is suitably qualified; and
 - (B) the Generator shall not be relieved of any of its obligations under this MOF, the TSRs or Contract for Difference and shall be liable for the acts and omissions of any person to whom it sub-contracts or delegates or with whom it enters into an arrangement to perform any or all of its obligations under this MOF or otherwise.

4. INSTALLATION

- 4.1 The Generator must ensure that a Main Meter and a Check Meter (and any associated Measurement Transformers, and any necessary fuses, test facilities and Communications Equipment) are installed before the initial Metering Commissioning Test in relation to the Facility Metering Equipment is carried out.
- 4.2 The Generator must ensure that the Main Meter and Check Meter are capable of accurately measuring Metered Volume, and for this purpose the point of measurement of the Main Meter and Check Meter must:
- (A) be located as close to the relevant Generating Unit as practicable;
 - (B) be located at the point indicated on the electrical schematic diagram notified to the CfD Counterparty in accordance with the terms of the Contract for Difference; and
 - (C) be capable of accurately recording:
 - (i) all input electricity used by the Facility; and
 - (ii) all output electricity generated by the Facility.
- 4.3 The Generator must ensure that parasitic load and site load are taken into account in measuring Metered Volume and that the Measurement Transformers for each Main Meter and Check Meter are appropriately located at a point after any such parasitic load or site load have been netted off from the output electricity generated by the Generator.

- 4.4 Testing facilities must be provided as close as practicable to the Meters, which enables such Meters to be routinely tested and/or changed safely with the circuit energised. A separate test facility is required for each set of current transformers used in the Metering System.

5. CALIBRATION

5.1 Meter calibration

- (A) Each Meter must be calibrated by the manufacturer prior to installation.
- (B) Each calibration must demonstrate that each Meter meets the relevant product standards for the class index of the Meter as specified in the TSRs.

5.2 Measurement Transformer calibration

- (A) All Measurement Transformers must be calibrated by the manufacturer so as to comply with the accuracy requirements set out in the TSRs prior to installation.
- (B) Each calibration must demonstrate that each Measurement Transformer meets the accuracy and measurement range requirements for the class index of the Measurement Transformer as set out in the TSRs.
- (C) For multi-ratio current transformers and voltage transformers, the transformer shall be calibrated for all possible ratios.

5.3 Calibration certificates

- (A) A certificate from the manufacturer must be obtained for each Meter and Measurement Transformer for every calibration conducted (a “**Calibration Certificate**”) and retained by the Generator for the Term. A Calibration Certificate must:
 - (i) be in the form of a manufacturer’s certificate that:
 - (a) states that the Meter or Measurement Transformer conforms to the relevant product standards in accordance with the TSRs; and
 - (b) shows actual errors determined through calibration for the relevant Meter or Measurement Transformer across its operating range and which demonstrates conformance with the relevant product standards under the TSRs; and
 - (ii) identify the serial number and type of Meter calibrated, the name of the testing body, the location of the calibrations, the date on which the calibrations were concluded and (where appropriate) the measurement uncertainties.
- (B) Calibration Certificates must be produced using verifiable standards in accordance with Good Industry Practice.

5.4 Subsequent Calibrations

- (A) If the Generator undertakes a subsequent calibration of a Main Meter or a Check Meter (each such calibration being a “**Subsequent Metering Calibration Test**”), the Generator must give the CfD Counterparty a minimum of ten (10) Business Days’ notice prior to undertaking that Subsequent Metering Calibration Test.
- (B) For each Subsequent Metering Calibration Test, a relevant Subsequent Metering Calibration Test Record in the form set out at Appendix 1 must be completed.

5.5 Meter Subsequent Calibration Timetable

	When	Action	From	To	Information Required	Method
1	10BD before Subsequent Metering Calibration Test is required	Notify the CfD Counterparty of an impending test and proposed date and time Generator submits the Key Meter Technical Details form	Generator	CfD Counterparty	Notification that a Metering Calibration Test is required and Key Meter Technical Details Form	Email
2	No later than 5BD after receipt of Subsequent Metering Calibration Test notification (set out in 1 above)	CfD Counterparty notifies the Generator whether or not it will attend	CfD Counterparty	Generator	General notification	Email
		Where the CfD Counterparty is attending: Both parties to agree date and time of test	Both parties	Both parties	Availability of each party	
		Where the CfD Counterparty is not attending: Generator to advise date and time of the test	Generator	CfD Counterparty	CfD Counterparty acknowledges test date and time	
3	On the agreed date of the Subsequent Metering Calibration Test date (in	Perform test and provide test results to the CfD Counterparty	Generator	CfD Counterparty	Test results, including Meter reads Certificate for calibration	If the CfD Counterparty did attend: Hard-copy of, and email with, test results

	When	Action	From	To	Information Required	Method
	accordance with 2 above)				equipment prepared in accordance with paragraph 5.8	If the CfD Counterparty did not attend: Email with test results
4	No later than 2BD after the Subsequent Metering Calibration Test date (set out in 3 above)	CfD Counterparty to approve test results and confirm whether test has been passed or failed	CfD Counterparty	Generator	Copy of the test results (electronic and hard-copy, as applicable) Certificate for calibration equipment prepared in accordance with paragraph 5.8	If the CfD Counterparty did attend: Notification in person and via email If the CfD Counterparty did not attend: Notification via email
5	Where the calibration equipment is deemed by the CfD Counterparty to be inaccurate and the CfD Counterparty notifies the Generator within 10 BD of a Subsequent Metering Calibration Test, the Generator must re-test pursuant to paragraph 5.6 of this MOF		N/A		N/A	

5.6 Re-Tests

Where, in relation to a Subsequent Metering Calibration Test, the calibration equipment is deemed to be inaccurate by the CfD Counterparty and the CfD Counterparty gives notice to the Generator within ten (10) Business Days of that Subsequent Metering Calibration Test, the Generator must undertake a re-test no later than five (5) Business Days after that notice in accordance with the timetable set out at paragraph 5.5 of this MOF (each such re-test being a “**Subsequent Metering Calibration Re-Test**”).

5.7 Replacement

Where a Main Meter or Check Meter has failed either a Subsequent Metering Calibration Test or a Subsequent Metering Calibration Re-Test, the Generator must promptly replace that Main Meter or Check Meter in accordance with paragraph 9 of this MOF.

5.8 Calibration Equipment

All certificates for calibration equipment used for a Subsequent Metering Calibration Test or a Subsequent Metering Calibration Re-Test must:

- (A) be prepared in accordance with the then in force UKAS Directive M3003;

- (B) be produced using standards verified by the National Physical Laboratory (NPL), or a calibration laboratory that has been accredited by the United Kingdom Accreditation Service (UKAS), or a similarly accredited international body;
- (C) include an overall accuracy and uncertainty of measurement statement for the relevant calibration equipment, where uncertainty is determined in accordance with the current UKAS Directive M3003 or any other method as agreed with the CfD Counterparty in writing beforehand; and
- (D) include the technical specification from the manufacturer of the relevant calibration equipment, which will be the error tolerances of the calibration equipment over a range of currents, voltages and power factors (or phase angles) as determined by the manufacturer.

6. COMMISSIONING

6.1 General

- (A) Prior to the Start Date, the Generator must perform an initial Metering Commissioning Test in relation to the Facility Metering Equipment. The Generator must give the CfD Counterparty a minimum of ten (10) Business Days' notice before undertaking the initial Metering Commissioning Test.
- (B) Any Metering Commissioning Test (other than the initial Meter Commissioning Test) must be undertaken in accordance with the timetables set out in paragraph 6.4 below.

6.2 Metering Commissioning Tests

- (A) Metering Commissioning Tests must be performed on site.
- (B) For each Metering Commissioning Test, a Metering Equipment Commissioning Record in the form set out at Appendix 1 must be completed.
- (C) The results of such tests shall be used to confirm and record, so far as appropriate, that:
 - (i) the current transformers are of the ratio specified in the Key Meter Technical Details, have the correct polarity and are correctly located to record the required power flow;
 - (ii) the voltage transformers are of the ratio specified in the Key Meter Technical Details, have the correct polarity and are correctly located to record the required power flow;
 - (iii) the relationships between voltages and currents are of the correct phase sequence and that phase rotation is standard at the Meter terminals;
 - (iv) the burdens on the Measurement Transformers are within the normal operating range of the Measurement Transformers;

- (v) the Meters are set to the same current transformer and voltage transformer ratios as the installed Measurement Transformers;
- (vi) the output of the Metering System correctly records the electricity in the primary system; and
- (vii) the Metering Equipment detects phase failure and operates the necessary alarms.

6.3 Reasons for carrying out a Metering Commissioning Test

- (A) In addition to the initial Metering Commissioning Test, a Metering Commissioning Test must be carried out:
- (i) in relation to the Metering System when there is a change to the Key Meter Technical Details; and
 - (ii) in relation to any item of Facility Metering Equipment when such item is repaired or replaced.
- (B) The “**Key Meter Technical Details**” are the Meter Serial Numbers, the Outstation Number of Channels, the Measurement Quantity ID, the Meter Multiplier, the Pulse Multiplier, the CT and/or VT serial numbers and the CT and/or VT ratios (as described in the TSRs).

6.4 Meter Commissioning Timetable

	When	Action	From	To	Information Required	Method
1	10BD before Metering Commissioning Test is required	Notify the CfD Counterparty of an impending test and proposed date and time Generator submits the Key Meter Technical Details form	Generator	CfD Counterparty	Notification that a Metering Commissioning Test is required and Key Meter Technical Details Form	Email
2	No later than 5BD after receipt of Metering Commissioning Test notification (set out in 1 above)	CfD Counterparty notifies the Generator whether or not it will attend	CfD Counterparty	Generator	General notification	Email
		Where the CfD Counterparty is attending: Both parties to agree date and time of test	Both parties	Both parties	Availability of each party	

	When	Action	From	To	Information Required	Method
		<p>Where the CfD Counterparty is not attending:</p> <p>Generator to advise date and time of the test</p>	Generator	CfD Counterparty	CfD Counterparty acknowledges test date and time	
3	On the agreed date of the Metering Commissioning Test date (in accordance with 2 above)	Perform test and provide test results to the CfD Counterparty	Generator	CfD Counterparty	Test results, including Meter reads	<p>If the CfD Counterparty did attend:</p> <p>Hard-copy of, and email with, test results</p> <p>If the CfD Counterparty did not attend:</p> <p>Email with test results</p>
4	No later than 2BD after the Metering Commissioning Test date (set out in 3 above)	CfD Counterparty to approve test results and confirm whether test has been passed or failed	CfD Counterparty	Generator	Copy of the test results (electronic and hard-copy, as applicable)	<p>If the CfD Counterparty did attend:</p> <p>Notification in person and via email</p> <p>If the CfD Counterparty did not attend:</p> <p>Notification via email</p>
5	No later than 5BD after a failed Metering Commissioning Test	Generator must re-test pursuant to paragraph 6.5 of this MOF	Generator must re-test pursuant to paragraph 6.5 of this MOF		N/A	

6.5 Re-Tests

Where any item of the Facility Metering Equipment has failed a Metering Commissioning Test, the Generator must undertake a re-test no later than five (5) Business Days after the failed Metering Commissioning Test in accordance with the timetable set out at paragraph 6.4 of this MOF.

7. PROVING

- (A) Prior to the Start Date, the Generator must perform an initial Proving Test in relation to the Metering System.
- (B) The Generator must give the CfD Counterparty a minimum of ten (10) Business Days' notice before undertaking the initial Proving Test.

- (C) Any Proving Test (other than an initial Proving Test) must be carried out in accordance with the timetables set out in paragraph 7.4 below.

7.2 Reasons for a Proving Test

The Generator must carry out a Proving Test on both the Main Meter and the Check Meter following a change to any of the Key Meter Technical Details (set out in paragraph 6.3(B) above).

7.3 Methods of Proving

- (A) Except with the prior written agreement of the CfD Counterparty, for the purposes of undertaking a Proving Test, the Generator shall:
 - (i) install or reconfigure the Metering System, commission the Metering System and record the reading for the Metered Volume in relation to a Settlement Unit while on site from the Meter Register;
 - (ii) use a hand-held unit (“**HHU**”) to interrogate all Meters in the Metering System and obtain the readings for the same Settlement Unit electronically; and
 - (iii) notify the CfD Counterparty of the Meter reads obtained.
- (B) For the Metering System to be deemed proven the Meter readings taken using a HHU must be the same as the physical Meter reading of the Meter Register (subject to any differences considered by the CfD Counterparty to be reasonable in the circumstances).
- (C) If the CfD Counterparty is not present for the Proving Test, the Generator must demonstrate that the physical Meter readings and those obtained using the Meter manufacturer’s software are not from the same source.

7.4 Proving Test Timetable

	When	Action	From	To	Information Required	Method
1	10BD before Proving Test is required	Notify the CfD Counterparty of an impending test and proposed date and time Generator submits the Key Meter Technical Details form	Generator	CfD Counterparty	Notification that a Proving Test is required and Key Meter Technical Details Form	Email
2	No later than 5BD after receipt of Proving Test notification (set out in 1 above)	CfD Counterparty notifies the Generator whether or not it will attend	CfD Counterparty	Generator	General notification	Email
		Where the CfD Counterparty is attending: Both parties to agree date and time of test	Both parties	Both parties	Availability of each party	
		Where the CfD Counterparty is not attending: Generator to advise date and time of the test	Generator	CfD Counterparty	CfD Counterparty acknowledges test date and time	
3	On the agreed date of the Proving Test date (in accordance with 2 above)	Perform test and provide test results to the CfD Counterparty	Generator	CfD Counterparty	Proving Test results, including Meter reads	If the CfD Counterparty did attend: Hard-copy of, and email with, test results
						If the CfD Counterparty did not attend: Email with test results
4	No later than 2BD after the Proving Test date (set out in 3 above)	CfD Counterparty to approve test results and confirm whether test has been passed or failed	CfD Counterparty	Generator	Copy of the test results (electronic and hard-copy, as applicable)	If the CfD Counterparty did attend: Notification in person and via email

						If the CfD Counterparty did not attend: Notification via email
5	No later than 5BD after a failed Proving Test	Generator must re-test pursuant to paragraph 7.5 of this MOF		N/A		

It is not necessary for all the processes required to complete a Proving Test to be carried out on the same day, other than where the CfD Counterparty attends the Proving Test, provided that the deadlines set out in the timetable above are met.

7.5 Re-Tests

Where the Metering System has failed the Proving Test, the Generator must undertake a re-test no later than five (5) Business Days after the failed Proving Test in accordance with the timetable set out at paragraph 7.4 of this MOF.

8. SEALING

- (A) Meters must be sealed, and the seals maintained at all times, in accordance with Good Industry Practice.
- (B) The Generator must update the Re-Sealing Form, set out in Appendix 1, promptly each time the Meter is re-sealed. The Re-Sealing Form must be maintained for the Term.
- (C) The Generator shall notify the CfD Counterparty immediately if the seal on any Facility Metering Equipment is broken or damaged or the security of the Facility Metering Equipment is otherwise compromised.

9. REPLACEMENT

In the event that the Generator installs or replaces the Facility Metering Equipment, it must ensure that it does so in compliance with the TSRs applicable to the Facility and the Generator's Private Network CfD Agreement.

10. THIRD PARTY METER OPERATOR

The Generator may appoint a third party meter operator to operate the Facility Metering Equipment provided any such third party meter operator is suitably qualified (in the opinion of the CfD Counterparty, acting reasonably). If the Generator does appoint such a third party meter operator, it shall promptly notify the CfD Counterparty of the identity of that third party meter operator and of any change to the identity of the person operating the Facility Metering Equipment from time to time.

11. METERING DATA

Metering data used for the purposes of calculating Metered Volume must be provided to the CfD Counterparty by the Generator in the file format stipulated by the CfD Counterparty, and as modified from time to time.

12. METERING CHECKS

- (A) The CfD Counterparty may undertake or require the Generator to undertake the tests and checks described in paragraphs 12.2 to 12.7 below in relation to a Metering System. The CfD Counterparty may require other tests or checks to be undertaken as it considers reasonably necessary from time to time.
- (B) Tests may be carried out either on-site at the Facility or off-site, as the CfD Counterparty or its appointed representative considers appropriate.

12.2 Metering System Checks

The following checks may be performed to verify the overall accuracy requirements of the Metering System:

- (A) that the test certificates provided relate to the Measurement Transformers;
- (B) that the test certificate calibration details in relation to the Metering Equipment meet the relevant requirements set out in the TSRs; and
- (C) that the Metering Equipment installed meets the specifications set out in the TSRs and, where required, that the Main Meters and Check Meters are correctly identified.

12.3 Measurement Transformer specification

- (A) The Measurement Transformer specification may be checked to ensure it complies with the standards set out in the TSRs and is consistent with the information provided by the Generator.
- (B) The following may be checked as part of the Measurement Transformer specification:
 - (i) ratio, class, rated burden and polarity from the labels physically attached to the Measurement Transformers and/or the identification plates attached to switchgear or other enclosures containing Measurement Transformers (although this may not always be practical for safety reasons); and
 - (ii) test records/certificates (including the Calibration Certificates) detailing specific measured errors associated with the Measurement Transformers on site.

12.4 Key Meter Technical Details

The Key Meter Technical Details (set out in paragraph 6.3(B) above) may be checked to ensure that they match the records of the CfD Counterparty using information provided by the Generator, including any Measurement Transformer error offsets and commissioning details.

12.5 Accuracy

- (A) The following checks may be performed to verify the overall accuracy requirements of the Metering System:
- (i) that the Measurement Transformers relate to Calibration Certificates provided;
 - (ii) that the Calibration Certificates in respect of the Meters and the Measurement Transformers meet the requirements set out in the TSRs; and
 - (iii) that the Facility Metering Equipment meets the requirements set out in the TSRs and the Main Meters and Check Meters are correctly identified.
- (B) The overall accuracy shall be determined by the CfD Counterparty and must be within the accuracy limits set out in the TSRs.

12.6 Correct Energy Measurement Test

The Metering Equipment may be checked to confirm that the Metered Volume is consistent with the electricity flowing in the circuit using the following methods:

- (A) comparing the Metered Volume derived from independently measured primary values to the Meter's instantaneous reading for the same period;
- (B) comparing the reading of Metered Volume derived from independently measured secondary values where the primary/secondary ratios can be established to the Meter reading for the same period;
- (C) using an alternative measurement device for comparison with the Meter;
- (D) using appropriate commissioning records; or
- (E) comparing the read from the Meter with the metering data provided for the purposes of the CfD Settlement Activities.

12.7 Quality of installation

All points may be checked, including (but not limited to):

- (A) labelling of equipment; and
- (B) whether installation has been undertaken in accordance with Good Industry Practice.

13. VALIDATION OF METERING DATA

The CfD Counterparty may undertake or require the Generator to undertake the following checks to validate the metering data. The CfD Counterparty may require other checks to be undertaken as it considers reasonably necessary from time to time.

13.1 Interrogation

The Outstation may be interrogated, or data automatically received from the Outstation may be reviewed, to check:

- (A) that the Outstation ID is the same as expected;
- (B) that the Outstation Number of Channels is the same as expected;
- (C) that the time of the Outstation does not differ by more than fifteen (15) minutes from UTC; or
- (D) that the individual alarms described in the TSRs are not flagged.

13.2 Main Meter / Check Meter comparison

- (A) Metering data recorded by the Main Meter and Check Meter must be compared on a half-hourly basis. Allowance shall be made for low load discrepancies.
- (B) Any discrepancy between the two values in excess of 1.5 times the accuracy requirements prescribed for the individual Meters at full load in accordance with the TSRs must be investigated further by the Generator.

14. INFORMATION AND RECORDS

14.1 Key Meter Technical Details

- (A) The Generator must ensure that a complete, up-to-date and accurate record of the Key Meter Technical Details is maintained at all times.
- (B) If any of the Key Meter Technical Details are changed, the Generator must notify the CfD Counterparty of the changes no later than 10 (ten) Business Days after the change has taken place using the Key Meter Details Form set out in Appendix 1.

14.2 Commissioning records

The Generator shall maintain records to show the instruments used for Metering Commissioning Tests by the Generator and shall retain such records for the Term.

14.3 Other records

- (A) The Generator must prepare and maintain, for the life of each relevant item of Facility Metering Equipment, including each Meter and Measurement Transformer, complete, up-to-date and accurate records as required by the CfD Counterparty from time to time.

- (B) Such records must include details of the following (including relevant dates and time periods, where applicable):
- (i) Facility name;
 - (ii) Facility address;
 - (iii) Generator Unique Reference Number;
 - (iv) Meter Serial Number;
 - (v) name of commissioning body (even if the Generator is the commissioning body);
 - (vi) date of commissioning;
 - (vii) name of persons responsible for organising and undertaking commissioning;
 - (viii) reason for commissioning;
 - (ix) Key Meter Technical Details (including any certificate identity);
 - (x) current transformers details (including any certificate identity);
 - (xi) voltage transformers details (including any certificate identity);
 - (xii) circuit name (where more than one);
 - (xiii) calibration results (including individual test errors for each Meter); and
 - (xiv) results of inspections, tests and observations.

Appendix 1
Metering Records and Forms

Part 1 – Metering Equipment Commissioning Record (Measurement Transformers)

1. DETAILS

Current Transformer	L1	L2	L3
Location of CTs			
Serial Number			
Burden			
Accuracy Class			
Make			
Type			
Available Ratios (in Amps)			
Ratio Selected (in Amps)			
CT pole face P2 facing Generating Unit?	Yes/No*	Yes/No*	Yes/No*

Voltage Transformer	L1	L2	L3
Location of VT			
Serial Number			
Burden			
Accuracy Class			
Make			
Type			
Available Ratios (in Volts)			
Ratio Selected (in Volts)			

L1 CT associated with L1 voltage? **Yes/No***

L2 CT associated with L2 voltage? **Yes/No***

L3 CT associated with L3 voltage? **Yes/No***

Standard Phase sequence at Testing Facility (L1, L2, L3)? **Yes/No***

CT shorting links left open? **Yes/No***

CTs and VTs Calibration Records attached?

Yes/No*

*Delete as appropriate

2. Ratio Verification

Test performed:

Primary Injection/Prevailing load tests*

Test Results:

Pass/Fail*

2.1 Primary Injection Tests

Instruments Used:

Include description and serial Nos:

Calibration expiry dates:

Description of test performed:

Test results:

Correct polarity verified?

Yes/No*

Current Transformer	L1	L2	L3
Primary Current Injected			
Secondary Current measured Hi Ratio			
Secondary Current measured Mid Ratio			
Secondary Current measured Low Ratio			
Ratio Calculation High Ratio			
Ratio Calculation Middle Ratio			
Ratio Calculation Low Ratio			

Voltage Transformers	L1 – L2	L2 – L3
Primary Volts Injected		
Secondary Volts measured High Ratio		
Secondary Volts measured Low Ratio		
Ratio Calculation High Ratio		

Ratio Calculation Low Ratio		
-----------------------------	--	--

2.2 Prevailing Load Tests

Instruments Used:

Include description and serial Nos:

Calibration expiry dates:

Current Transformer	L1	L2	L3
Primary Measurement			
Secondary measurement			
Ratio Calculation			

3. CT Polarity Verification

Description of Tests performed

For example, verification with known standard CT (buck & boost tests) or DC flick test.

Instruments Used:

Include description and serial Nos:

Calibration expiry dates:

All tests performed and are correct? **Yes/No***

Tests performed by:

Date of Tests:

*Delete as appropriate

Part 2 – Metering Equipment Commissioning Record Part 2 (Meters)

1. Details

Meters			
Serial Number			
Manufacturer			
Type			
Meter CT ratio			
Meter VT ratio			
Register Readings			
Date & Time			
KW demand			

Correct phase sequence at Meter terminals? **Yes/No***

Current and Voltages have correct relationship? **Yes/No***

CT Burdens

CT secondary cable runVA

MetersVA

Other ...*description*VA

Total CT BurdenVA

Overall Burden on CTs is within limits? **Yes/No***

VT Burdens

VT secondary cable runVA

MetersVA

Other ...*description*VA

Total VT BurdenVA

Overall Burden on VTs is within limits? **Yes/No***

Confirm that the Meter is set to the actual ratios of the CTs and VTs **Yes/No***

CTs and VTs located where indicated on electrical schematic diagram? **Yes/No***

If No state location and reason:
.....

Phase fail alarms operating correctly? **Yes/No***

AI register advances when electricity flows toward the Generating Unit? **Yes/No***

CT shorting links left open? **Yes/No***

Meter potential fuse ratings..... Amps

Local fuse rating Amps

Commissioning form Part 1 verified and correct **Yes/No***

All connections tight? **Yes/No***

Tests performed by:

Date of Tests:.....

*Delete as appropriate

Subsequent Metering Calibration Test Record – Class 1 Meters

CfD ID:.....

Meter Type:.....

Serial Number:.....

Meter CT ratio:.....

Meter VT ratio:.....

Class:.....

Circuit Configuration:.....

Test instrument:.....

Serial Number:.....

Type:.....

Accuracy Class:.....

Date last tested:.....

Export / Import¹ Direction

P/Q	% Rated Voltage	% Rated Current	Phase Angle Applied	Phase	Instrument Error ²	Plant Error ³	Meter Error ⁴	Measurement Uncertainty ⁵
P	100	1.0 I _n ⁶	0°	L1/L2/L3				
				L1				
				L2 ⁷				
				L3				
		1.0 I _n ⁶	60°	L1				
				L2 ⁷				
				L3				
		0.05 I _n ⁶	0°	L1/L2/L3				
		Q		1.0 I _n ⁶	90°	L1/L2/L3		

Import/Export¹ Direction

P/Q	% Rated Voltage	% Rated Current	Phase Angle Applied	Phase	Instrument Error ²	Plant Error ³	Meter Error ⁴	Measurement Uncertainty ⁵
P	100	1.0 I _n ⁶	0°	L1/L2/L3				

Temperature:

Date of Test:/...../.....

Location of Test:

Test Sheet Reference No.:

Tested by:
(print name)

Signed:

Explanatory notes:

¹ The Meter will be tested in the direction it predominantly operates in, i.e. for a Generator this will be in the export direction. If the same measuring element is used to measure both import and export then one additional test point is required in the reverse direction. Delete as appropriate.

² The displayed error on the test instrument used to test the Meter; this will include the effect of any applied meter compensations for transformer errors/losses, if applicable.

³ The plant error applied to the Meter at that % rated current and power factor based on the transformer errors/losses calculation.

⁴ The actual error of the Meter once the effect of the Plant Error is removed from the raw instrument error.

⁵ Measurement uncertainty calculated to a confidence level of 95 %, $k=2$.

⁶ Test point used is the nominal value of current the Meter is rated for, i.e. if the nominal current of the meter is 5A the test would be done at 5A.

⁷ L2 test point is only applicable if the meter has three measuring elements, i.e. in a 3 Phase 4 wire Meter.

Subsequent Metering Calibration Test Record – Class 2 and Class 3 Meters

CfD ID:.....

Meter Type:.....

Test instrument:.....

Serial Number:.....

Serial Number:.....

Meter CT ratio:.....

Type:.....

Meter VT ratio:.....

Accuracy Class:.....

Class:.....

Date last tested:.....

Circuit Configuration:.....

Export/Import¹ Direction

P/Q	% Rated Voltage	% Rated Current	Phase Angle Applied	Phase	Instrument Error ²	Plant Error ³	Meter Error ⁴	Measurement Uncertainty ⁵		
P	100	1.0 I _{max} or 1.2 I _n / 1.5 I _n or 2.0 I _n ⁶	0°	L1/L2/L3						
			60°	L1/L2/L3						
			-36.9°	L1/L2/L3						
		0.1 I _n	60°	L1/L2/L3						
			-36.9°	L1/L2/L3						
		0.05 I _n	0°	L1/L2/L3						
				L1						
				L2						
		0.02 I _n	60°	L1/L2/L3						
				-36.9°	L1/L2/L3					
		0.01 I _n	0°	L1/L2/L3						
		Q		1.0 I _{max} or 1.2 I _n / 1.5 I _n or 2.0 I _n ⁶	90°	L1/L2/L3				
						L1/L2/L3				
				0.1 I _n	30°	L1/L2/L3				
-30°	L1/L2/L3									
0.05 I _n	90°			L1/L2/L3						
				L1						
				L2						
				L3						

Import/Export¹ Direction

P/Q	% Rated Voltage	% Rated Current	Phase Angle Applied	Phase	Instrument Error ²	Plant Error ³	Meter Error ⁴	Measurement Uncertainty ⁵
P	100	1.0 I _{max} or 1.2 I _n / 1.5 I _n or 2.0 I _n ⁶	0°	L1/L2/L3				

Temperature:

Date of Test:/...../.....

Location of Test:

Test Sheet Reference No.:

**Tested
(print name)**

by:

Signed:

Explanatory Notes:

¹ The Meter will be tested in the direction it predominantly operates in, i.e. for a Generator this will be in the export direction. If the same measuring element is used to measure both import and export then one additional test point is required in the reverse direction. Delete as appropriate.

² The displayed error on the test instrument used to test the Meter; this will include the effect of any applied meter compensations for transformer errors/losses, if applicable.

³ The plant error applied to the Meter at that % rated current and power factor based on the transformer errors/losses calculation.

⁴ The actual error of the Meter once the effect of the plant error is removed from the raw instrument error.

⁵ Measurement uncertainty calculated to a confidence level of 95 %, k=2.

⁶ Test point used is dependent on the current rating of the Meter and will be the highest value of current the Meter is rated for, i.e. if the nominal current of the meter is 5A the test would be done at 6A (1.2 x 5A). 1.5 I_n or 2.0 I_n is only used if the Meter is designed for it and is determined by the overload capacity of the circuit, if unspecified test at 1.0 I_{max}. Delete as appropriate.

⁷ L2 test point is only applicable if the meter has three measuring elements, i.e. in a 3 Phase 4 wire Meter.

Key Meter Technical Details Form

To: [●] (the "CfD Counterparty")
[Address]

From: [●] (the "Generator")
[Unique reference number: [●]]

Dated: [●]

KEY METER TECHNICAL DETAILS

2. The following Key Meter Technical Detail was changed on **[date]**:

.....

3. The Key Meter Technical Details are now as follows:

Outstation ID.....

Meter Serial Number.....

Outstation Number of Channels.....

Measurement Quantity ID.....

Meter Multiplier.....

Pulse Multiplier.....

CT Serial Number.....

VT Serial Number.....

CT Ratios.....

VT Ratios.....

Print Name

Signed.....

Date.....

Re-Sealing Form

Generator:

Geographical Coordinates of the Facility:

Name of Project:

Circuit Name	Metering Equipment Sealed (e.g., Meter, Outstation, Meter Panel Door, Meter Cabinet Rear Door, Potential Fuses, Test Terminal Block, etc)	Date Seals Applied	Sealing Pliers Number	Signature of Person Applying Seals

Annex 7
(Private Network Technical System Requirements)

CONTENTS

1. Interpretation
2. Metered Volume
3. Metering Equipment Criteria
4. Calibration

ACRONYMS

BS EN: British Standard European Norm

CT: Current Transformer

HHU: Hand-held Interrogation Unit

ID: Identifier

IEC: International Electrotechnical Commission

IU: Interrogation Unit

kW: Kilowatt

kWh: Kilowatt hours

MVA: Megavolt ampere

MWh: Megawatt hours

UTC: Co-ordinated Universal Time

VT: Voltage Transformer

1. INTERPRETATION

1.1 In these TSRs:

- (A) in relation to any Metering System, the requirements set out in this document shall be construed as requirements in relation to all of the Metering Equipment comprised or required to be comprised in that Metering System;
- (B) references to a Metering System include a Metering System which is to comprise Metering Equipment which a third party is or will be required to calibrate, install, commission, prove, operate, maintain or test;
- (C) references to Metering Equipment in the context of a Metering System or the Generator are to all of the Metering Equipment which is or is to be comprised in such Metering System (except that references to Metering Equipment shall not include references to Metering Equipment which comprises a Boundary Point Metering System, and references to a Metering System shall not include a Boundary Point Metering System); and
- (D) where the Facility is a Dual Scheme Facility, other than in paragraph 2.1.1 of these TSRs, references to Metered Volume shall not include Imported Input Electricity.

2. METERED VOLUME

2.1 Required measurements

- (A) The following electricity measurements are required in relation to each Settlement Unit for the purposes of calculating Metered Volume:
 - (i) all output electricity generated by the Facility;
 - (ii) if the Facility is not a Dual Scheme Facility, all input electricity comprising parasitic and site load used by the Facility; and
 - (iii) if the Facility is a Dual Scheme Facility, all input electricity comprising the parasitic load used by the Facility and the Imported Input Electricity,in each case, all such values to be converted to kWh and expressed to three (3) decimal places.
- (B) The Meters must be capable of recording the relevant measurements described in (A)(i), (A)(ii) and (A)(iii) above (other than Imported Input Electricity, which shall be measured by Metering Equipment comprising a Boundary Point Metering System and which is outside the scope of these TSRs) for each Settlement Unit.

2.2 Accuracy requirements

The overall accuracy of the electricity measurements in respect of each Meter must be within the following limits of error at all times:

Metering Type 1 (Metering of circuits rated greater than 100MVA)

Condition	Limits of error at stated system power factor	
Current expressed as a percentage of Rated Measuring Current	Power Factor	Limits of Error
120% to 10% inclusive	1	± 0.5%
Below 10% to 5%	1	± 0.7%
Below 5% to 1%	1	± 1.5%
120% to 10% inclusive	0.5 lag and 0.8 lead	± 1.0%

Metering Type 2 (Metering of circuits not exceeding 100MVA)

Condition	Limits of error at stated system power factor	
Current expressed as a percentage of Rated Measuring Current	Power Factor	Limits of Error
120% to 10% inclusive	1	± 1.0%
Below 10% to 5%	1	± 1.5%
Below 5% to 1%	1	± 2.5%
120% to 10% inclusive	0.5 lag and 0.8 lead	± 2.0%

Metering Type 3 (Metering of circuits not exceeding 10MVA)

Condition	Limits of error at stated system power factor	
Current expressed as a percentage of Rated Measuring Current	Power Factor	Limits of Error
120% to 10% inclusive	1	± 1.5%
Below 10% to 5%	1	± 2.0%
120% to 10% inclusive	0.5 lag and 0.8 lead	± 2.5%

3. METERING EQUIPMENT CRITERIA

3.1 General

- (A) Although these TSRs identify separate items of equipment, nothing in them prevents such items being combined to perform the same function, provided the requirements of these TSRs, the MOF and the Contract for Difference are met.
- (B) The voltage supply to any Meter, display and Outstation must be connected such that it is normally energised to facilitate reading of the Meter Register(s) and local and remote interrogation of the Outstation.
- (C) Facility Metering Equipment (other than outdoor Measurement Transformers) must be accommodated in a clean and dry environment.

3.2 Measurement Transformers

- (A) The terms "current transformer" and "voltage transformer" used in paragraphs 3.3 and 3.4 below do not preclude the use of other measuring techniques with a performance equal to that specified for such Measurement Transformers.
- (B) For each circuit, current transformers ("**CT**") and voltage transformers ("**VT**") must meet the requirements set out in paragraphs 3.3 and 3.4 below.
- (C) Where a combined unit measurement transformer (i.e., VT and CT) is used, the Tests for Accuracy described in clause 8 of IEC Standard 44-3 in relation to mutual influence effects must also be met.
- (D) All Measurement Transformers must be of a wound construction.

3.3 Current transformers

- (A) All CTs for Type 1, 2 and 3 Meters must meet the following criteria:

Type of Meter	Relevant Standard	Minimum Class Accuracy	No. of sets	Usage
1	IEC 6189-2	0.2s	2	1 set of CTs dedicated to the Main Meter only and 1 set supplying the Check Meters. Check Meter CTs can be used for other purposes provided that such Check Meter CTs comply with the accuracy requirements in paragraph 2.2 of these TSRs.
2	IEC 6189-2	0.2s	1	CTs must be dedicated to the CfD Settlement Activities, supplying both Main Meters and Check Meters. An additional set of CTs may be fitted for the Check Meter which may also be used for other purposes provided that

Type of Meter	Relevant Standard	Minimum Class Accuracy	No. of sets	Usage
				such Check Meters comply with the accuracy requirements in paragraph 2.2 of these TSRs.
3	IEC 185	0.5	1	1 set of CTs for Main Meters and Check Meters' CfD Settlement Activities purposes, but may also have other uses if the overall accuracy requirements in paragraph 2.2 of these TSRs are met.

3.4 Voltage transformers

- (A) The primary winding of VTs must be connected to the circuits being measured.
- (B) The secondary windings of VTs for Type 1, 2 and 3 Meters must meet the following criteria:

Type of Meter	Relevant Standard	Minimum Class Accuracy	No. of sets	Usage
1	IEC 61869-3	0.2	2 VTs (or 1 VT with two (2) or more secondary windings)	1 VT secondary winding dedicated to the Main Meter for CfD Settlement Activities purposes only. Check Meter VTs can be used for other purposes provided that such Check VT Meters comply with the accuracy requirements in paragraph 2.2 of these TSRs.
2	IEC 61869-3	0.5	1	VT supplying Main Meters and Check Meters for the CfD Settlement Activities only. VT secondary winding must be dedicated to the CfD Settlement Activities, supplying both Main Meters and Check Meters. An additional VT or secondary winding may be used for the Check Meter which may also be used for other purposes provided that such Check Meter complies with the accuracy requirements in paragraph 2.2 of these TSRs.
3	IEC 61869-3	1	1	CfD Settlement Activities purposes, but may also have other uses if overall accuracy requirements in paragraph 2.2 of these TSRs are met

3.5 Fusing and testing facilities

- (A) Separate fusing must be provided locally for:
- (i) the Main Meter;
 - (ii) the Check Meter; and
 - (iii) any other Facility Metering Equipment burden.
- (B) Local fusing must discriminate with the source fusing.
- (C) A typical arrangement is illustrated in Appendix 1 of these TSRs.
- (D) Where CTs are used on low voltage installations, the voltage supply to the Facility Metering Equipment identified in paragraph (A) above must be fused as close as

practicable to the point of that supply with a set of isolating links, suitably identified, provided locally to that Metering Equipment. If that point of supply is close to the Facility Metering Equipment identified in paragraph (A), then the isolating links may be omitted.

3.6 Meters

- (A) All Meters must be static.
- (B) Each Main Meter and Check Meter may be used for a period not exceeding ten (10) years from the later of the date of manufacture and the date of any calibration test carried out in accordance with paragraph 4.1 below.
- (C) All Meters must include Outstation functionality.
- (D) Meters must be configured so that the number of measuring elements is equal to or one less than the number of primary system conductors. These include the neutral conductor, and/or the earth conductor where system configurations enable the flow of zero sequence energy.
- (E) All Meters supplied via Measurement Transformers must be set to the actual primary and secondary ratings of the Measurement Transformers and the ratios must be displayed and downloaded during the interrogation process.
- (F) All Meters must include a non-volatile Meter Register of cumulative electricity for each measurement required under paragraph 2.1(A) of these TSRs, other than the Imported Input Electricity where the Facility is a Dual Scheme Facility. The Meter Register(s) must not roll-over more than once within a six (6) month period.
- (G) All Meters must comply with the following accuracy standards:

Type of Meter	Minimum Class Accuracy	Relevant Standard
1	0.2s	BS EN 62053-22
2	0.5s	BS EN 62053-22
3	1	BS EN 62053-21

3.7 Displays and facilities for Generator or supplier information

The Main Meter and the Check Meter must display the following primary information (not necessarily simultaneously):

- (A) the electricity measurements described in paragraph 2.1(A) of these TSRs;
- (B) current time (in accordance with paragraph 3.10(A) of these TSRs) and date; and
- (C) the CT and/or VT ratios to which the Meter has been programmed (where appropriate).

3.8 Outstation

- (A) The Facility Metering Equipment must include an Outstation System in respect of each Meter to transfer and receive metering data to and from the Instation.
- (B) The Outstation must be configured so as to ensure that the metering data is capable of being used by the CfD Counterparty to calculate Metered Output.
- (C) A unique Outstation ID must be provided for the purpose of transferring stored metering data from the Outstation to the Instation.
- (D) Metering data must be collected by the Instation by way of interrogation of the Outstation at least once during each Billing Period.
- (E) Where a separate modem associated with the Outstation System is used, either (i) the modem must be provided with a separately fused supply from a secure supply or a measurement VT; or (ii) a line or battery powered modem must be used.

3.9 Metering data storage

- (A) For the purposes of this paragraph 3.9, "**Settlement Unit**" shall mean each half hour period in a day divided into half hour-long periods starting at 00:00 on such day.
- (B) Metering data storage facilities must be provided for the metering data. Metering data storage facilities must meet the following requirements:
 - (i) it must be possible to identify the Settlement Unit for each reading of Metered Volume;
 - (ii) the storage capacity must be:
 - (a) 48 Settlement Units, starting at 00:00 on each day and running consecutively;
 - (b) for a minimum of twenty (20) Billing Periods;
 - (iii) the stored values of metering data must be integer multiples of kWh;
 - (iv) the resolution of the electricity transferred into the demand registers must be within $\pm 0.1\%$ (at full load) of the amount of input and output electricity measured by the associated Meter;
 - (v) the value of any electricity measured in a Settlement Unit but not stored in that Settlement Unit must be carried forward to the next Settlement Unit;
 - (vi) in the event of an Outstation supply failure, the Outstation must: (i) protect all metering data stored up to the time of the failure; and (ii) maintain the time accuracy in accordance with paragraph 3.10 below;

- (vii) where, in relation to a Settlement Unit: (i) partial values for Metered Volume are recorded; (ii) zero values for Metered Volume associated with an Outstation supply failure are recorded; or (iii) an Outstation supply failure and/or restoration occurs, the metering data must be marked so that the Instation can identify the relevant Settlement Units and Metered Volumes;
- (viii) the clock, calendar and all metering data must be supported for a period of twenty (20) days without an external supply connected to cater for continuous supply failures;
- (ix) any "read" operation must not delete or otherwise alter any stored metering data; and
- (x) upon demand by the Instation, the Outstation must provide all of the metering data stored from the start of any specified Billing Period.

3.10 Time keeping

- (A) The Outstation time must be set to Co-ordinated Universal Time Clock (UTC). The Outstation time shall not switch to or from British Summer Time (BST).
- (B) Time synchronisation of the Outstation may be performed: (i) remotely by the Generator as part of the normal interrogation process; or (ii) locally by an Interrogation Unit ("IU").
- (C) When time synchronisation occurs, the relevant Settlement Unit must be marked with an alarm indication as described in paragraph 3.11 below.
- (D) The overall limits of error for timekeeping, allowing for a failure to communicate with the Outstation for up to twenty (20) days, shall be as follows:
 - (i) each Settlement Unit must end within ± 20 seconds of UTC; and
 - (ii) the duration of each Settlement Unit must be within ± 1.8 seconds of thirty (30) minutes according to UTC, except where time synchronisation has occurred in a Settlement Unit.

3.11 Monitoring facilities

- (A) Monitoring facilities must be provided to record each occurrence of the following:
 - (i) phase failure of any one or a combination of phases;
 - (ii) (where a supply is fitted) Facility Metering Equipment resets caused other than by a supply failure;
 - (iii) (where a battery is fitted) battery monitoring;
 - (iv) interrogation port access which changes time and/or date;

- (v) where different from (d), Settlement Unit(s) which have been truncated or extended by a time synchronisation;
 - (vi) interrogation port access which changes data other than time and/or date;
 - (vii) reverse running (where applicable); and
 - (viii) any other detected error in Facility Metering Equipment functionality.
- (B) When an event described in paragraph (A) above occurs, it must be reported as a separate alarm indication tagged to the relevant Settlement Unit locally by way of an IU or by way of automatic online communication.
- (C) Any alarm indications must not be cancelled or deleted by the interrogation process and are to be retained with the metering data until overwritten. The alarm must reset automatically when the relevant occurrence has been cleared.

3.12 Communications

- (A) Outstations must provide both local and remote interrogation facilities, from separate ports.
- (B) To prevent unauthorised access to the metering data in the Facility Metering Equipment, a security scheme must be incorporated for both local and remote access.
- (C) A security scheme must include the following separate security levels:
- (i) Level 1: Password for read only of the following metering data, which must be transferable on demand as part of the interrogation process:
 - (a) Outstation ID;
 - (b) input electricity and output electricity for Main Meters and Check Meters;
 - (c) cumulative Metered Volumes as described in paragraph 2.1 of these TSRs for Main Meters and Check Meters;
 - (d) maximum demand (“**MD**”) for kW per programmable charging period i.e., monthly, statistical review period;
 - (e) multi-rate cumulative electricity as specified by the Generator;
 - (f) the Measurement Transformer ratios;
 - (g) the Measurement Transformer error correction factor where this is a constant factor applied to the entire dynamic range of the Meter;
 - (h) alarm indications; and

- (i) Outstation time and date;
- (ii) Level 2: Password for:
 - (a) corrections to the time and/or date; and
 - (b) resetting of the MD;
- (iii) Level 3: Password for programming of:
 - (a) the displays and facilities as described in paragraph 3.7 of these TSRs;
 - (b) the Measurement Transformer ratios;
 - (c) the Measurement Transformer error correction where this is a constant factor applied to the entire dynamic range of the Meter; and
 - (d) the Passwords for levels 1, 2 and 3.

In addition, it must be possible to read additional information within the Facility Metering Equipment to enable the programmed information to be confirmed.

- (iv) Level 4: Password or removal of Facility Metering Equipment cover(s) necessitating the breaking of a seal for:
 - (a) calibration of the Facility Metering Equipment;
 - (b) setting the Measurement Transformer ratios;
 - (c) programming the Measurement Transformer error correction factor where this is other than a single factor; and
 - (d) programming the level 3 Password and the level 4 Password, if appropriate.
- (D) Other than in relation to the level 4 Password, each Password must also allow the functions associated with the previous levels to be carried out, i.e:
 - (i) the level 3 Password must allow the level 2 functions to be carried out; and
 - (ii) the level 2 Password must allow the level 1 functions to be carried out.
- (E) The Generator must ensure that the communications protocol used in relation to the Facility Metering Equipment requires that access to the metering data within the Facility Metering Equipment is determined by the level of the Password.
- (F) A counter logging the number of unauthorised attempts (i.e., Password comparison failures) to access Facility Metering Equipment via the local and

remote ports must be incorporated as part of the log-on process. This counter must reset to zero at every hour change (i.e., 01:00, 02:00, etc.). If the counter reaches seven (7), access must be prohibited at all levels until the counter resets at the next hour change.

3.13 Appropriate seals

The Generator must ensure that the Facility Metering Equipment is appropriately sealed so as to provide assurance that:

- (A) all standards applicable to the Generator under Electricity Safety, Quality and Continuity Regulations 2002 are being complied with; and
- (B) anti-tamper protection is established and maintained in accordance with the Reasonable and Prudent Standard.

3.14 Local interrogation

An interrogation port must be provided for each Outstation.

3.15 Remote interrogation

- (A) Remote interrogation facilities must be provided. Such facilities must be capable of checking for errors in the communications between the Outstation System and the Instation.
- (B) It must not be possible to disconnect the remote communications connection to or from the Outstation without the breaking of an appropriate seal (as described in paragraph 3.13 of these TSRs).

3.16 Interrogation Unit

- (A) An IU, such as a Hand-held Unit (“**HHU**”) may be used for programming, commissioning, maintenance, fault finding and the retrieval of stored metering data. The metering data retrieved by the IU should be compatible with the Instation.
- (B) The IU must have a built-in security system, such as a password, so that the IU becomes inoperative and non-interrogable if it is lost, stolen or otherwise compromised. Any such password may be applied when the device is turned on or when the IU software application is opened.

3.17 Additional features

Additional features may be incorporated within or associated with the Facility Metering Equipment provided these must not prevent, hamper or otherwise interfere with the CfD Settlement Activities.

4. CALIBRATION

4.1 Meter calibration

- (A) Calibration must be carried out to the relevant product standard with tests at the load points specified in Table 1 of these TSRs, in accordance with the accuracy requirements set out in Table 2 and Table 3 of these TSRs.
- (B) The relevant product standards are BS EN 62053-22 (Active static Meters of Classes 0.2S and 0.5S), 62053-11 (Active electromechanical Meters of Classes 0.5, 1 and 2), 62053-21 (Active static Meters of Classes 1 and 2), or 62053-23 (Reactive static Meters of Classes 2 and 3)).
- (C) Calibration Certificates must include a measurement uncertainty evaluation which shall be determined to a confidence level of 95 per cent. or greater in accordance with the UKAS Directive M3003. Measurement uncertainties for Meters must be within the limits set out in Table 4 of these TSRs.
- (D) No compensation shall be applied to any Meter pursuant to these TSRs or the MOF.
- (E) Calibration will be conducted using the Meter's metrological test output. However, for at least one load point, it shall also be confirmed that the physical display and the pulse output, where used for purposes of the CfD Settlement Activities, are registering to the necessary standards of accuracy (i.e., all outputs fitted give the same measurement result).

4.2 Measurement Transformer calibration

- (A) Calibration of Measurement Transformers must demonstrate compliance with the IEC 61869-2 and/or (as appropriate) IEC 61869-3 accuracy and measurement range requirements, as appropriate for the Measurement Transformer's class index.
- (B) Calibration Certificates must include a measurement uncertainty evaluation which shall be determined to a confidence level of 95 per cent. or greater in accordance with the UKAS Directive M3003. In the case of Measurement Transformers for Type 1 and 2 metering the accuracy test result errors including measurement uncertainty shall not exceed 1.5 times the permitted errors in the relevant specifications involved.

4.3 Test points

- (A) Meter Calibrations should be performed at the test points (values of currents) outlined in Table 1 below. The measured errors at these test points should not exceed the percentage error limits stated in Table 2 below.
- (B) Where a test point is outside the range of the value of current outlined in Table 1 below, the percentage error limit shall be that applicable to the value of current that is closest to the test point value.

- (C) It should be noted that “I_b” refers to the basic current of a whole-current Meter, “I_n” refers to the rated current of a transformer-operated Meter and “I_{max}” to the maximum current rating of a Meter.

Table 1: Testing Points for Type 1, 2 and 3 Meters

Test Point	Type of Meter		
	Unity	0.5 Inductive	0.8 Capacitive*
Value of current (I)	Power Factor (Cos φ)		
0.01 I _n	X		
0.02 I _n		X	X
0.05 I _n	X (3), Y		
0.1 I _n		X	X
1.0 I _n	X (2), Y (5)	X (4)	X
1.0 I _{max} or 1.2 I _n or 1.5 I _n or 2.0 I _n **	X (1)	X	X

Notes:

These tests shall be carried out for input electricity and output electricity directions for a given metering point. If the same measuring element is used for both input electricity and output electricity,

one additional test point only (at “1.0 I_n”, Unity Power Factor, balanced) is required in the reverse direction.

X = all elements combined.

Y = each element on its own.

X,Y = tests should be carried out both on all elements combined, and each element on its own.

* = tests at 0.5 capacitive Power Factor is acceptable.

** = determined by overload capacity of circuit. If unspecified, test at “1.0 I_{max}”.

Numbers in brackets identify, for reference only, those tests specified in Statutory Instruments 1998 No. 1566 Schedule 1, Table 2 and Schedule 3, Table 2.

All 1.0 I_n test points are only applicable to Type 3 Meters.

0.05 I_n UPF Y (single phase) are only applicable to Type 1 and 2 Meters.

4.4 Accuracy Tables for Meters

Table 2: Summary of Class accuracy requirements for Type 1, 2 and 3 Meters (Polyphase meters with Balanced Loads [Types 1, 2 and 3] and Single-phase load but balanced polyphase voltages applied to voltage circuits [Type 3 only])

Value of current (I)	Power factor (Cos ϕ)	Percentage error limits for Types of Meters		
		1 0.2s	2 0.5s	3 1
For transformer-operated Meters				
$0.01 I_n \leq I \leq 0.05 I_{max}$	1	± 0.4	± 1.0	N/A
$0.02 I_n \leq I \leq 0.05 I_{max}$	1	N/A	N/A	± 1.5
$0.05 I_n \leq I \leq I_{max}$	1	± 0.2	± 0.5	± 1.0
$0.02 I_n \leq I \leq 0.1 I_n$	0.5 inductive 0.8 capacitive	± 0.5 ± 0.5	± 1.0 ± 1.0	N/A N/A
$0.05 I_n \leq I \leq 0.1 I_n$	0.5 inductive 0.8 capacitive	N/A N/A	N/A N/A	± 1.5 ± 1.5
$0.1 I_n \leq I \leq I_{max}$	0.5 inductive 0.8 capacitive	± 0.3 ± 0.3	± 0.6 ± 0.6	± 1.0 ± 1.0

Table 3: Summary of Class accuracy requirements for Type 1, 2 and 3 Meters (Polyphase meters carrying a Single-phase load but balanced polyphase voltages applied to voltage circuits [Types 1 and 2 only])

Value of current (I)	Power factor (Cos ϕ)	Percentage error limits for Types of Meters	
		1 0.2s	2 0.5s
For transformer-operated Meters			
$0.05 I_n \leq I \leq I_{max}$	1	± 0.3	± 0.6
$0.1 I_n \leq I \leq I_{max}$	0.5 inductive	± 0.4	± 1.0

4.5 Measurement uncertainty

Table 4: Measurement uncertainty test for Type 1, 2 and 3 Meters

Maximum overall uncertainty of calibration equipment	Type of Meter under test		
	1	2	3
Measurements at unity power factor	$\pm 0.06\%^a$	$\pm 0.1\%^b$	$\pm 0.4\%$
Measurements at other than unity power factor	$\pm 0.12\%$	$\pm 0.2\%$	$\pm 0.6\%$

^a = means $\pm 0.1\%$ for measurements at load points below $0.05 I_n$.

^b = means $\pm 0.1\%b$ where b is $\pm 0.2\%$ for measurement at load points below $0.05 I_n$

The overall uncertainty level shall be calculated to a 95 per cent. confidence level in accordance with UKAS M3003.

Appendix 1 Fusing

The following diagram shows a typical arrangement for the fusing requirements. The diagram is non-exhaustive and is provided for reference only.

Figure 1: Fusing arrangements for cable runs of more than 30 metres distance between source fusing and local means of isolation^{43 44}.

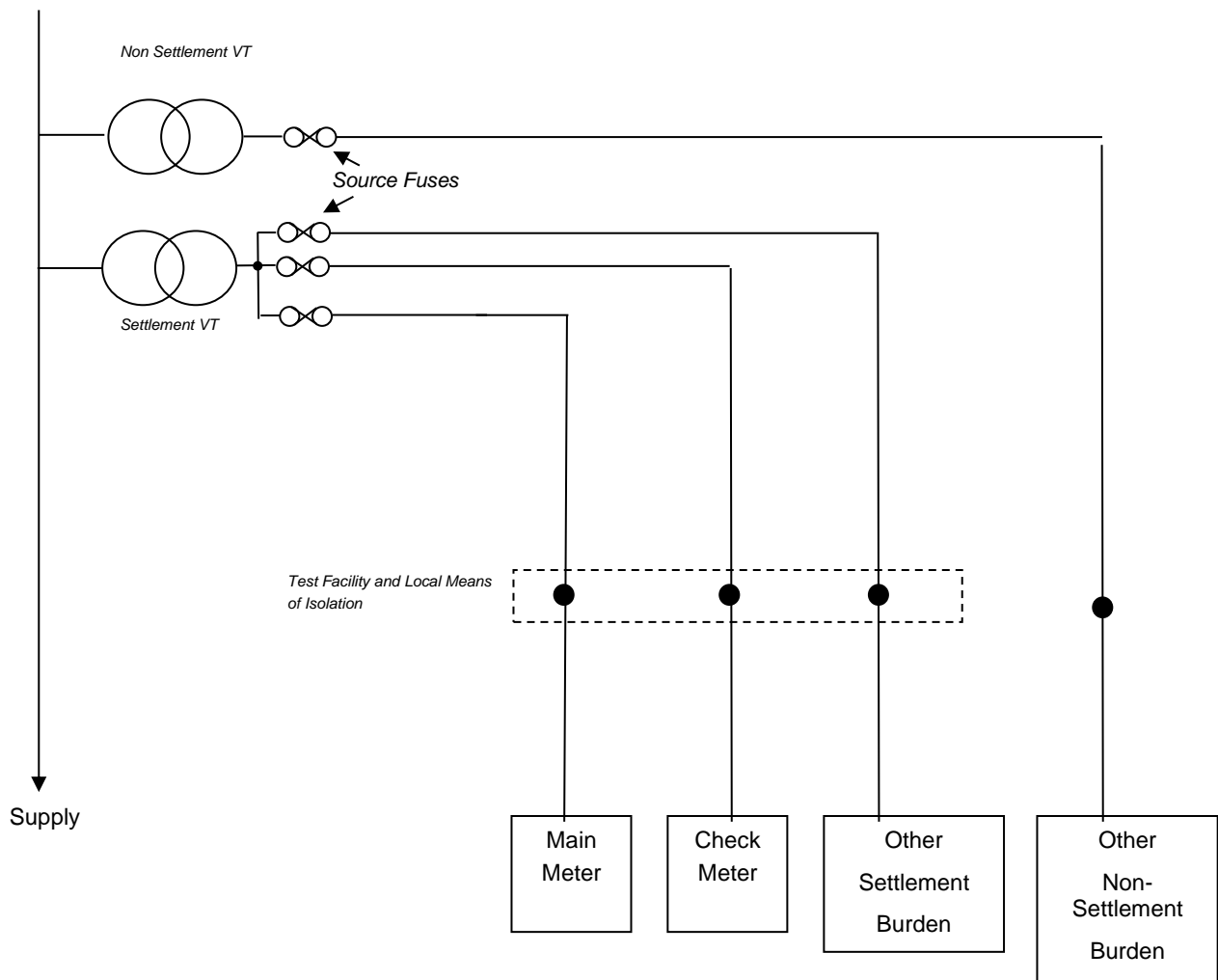

URN 15D/095

⁴³ Local isolation may be provided by the use of solid links or fuses and may be placed on either side of the test terminal block. Where fuses are to be used, the additional burden shall be accounted for.

⁴⁴ Check Meters and other burden may be supplied via an additional secondary winding of the VT.

**Annex 8
(Notices)**

(Loss of Route to Market Notice)

To: [●] (the “CfD Counterparty”)
[Address]

From: [●] (the “Generator”)
[Unique reference number: [●]]

Dated: [●]

CONTRACT FOR DIFFERENCE – LOSS OF ROUTE TO MARKET NOTICE

Dear Sirs,

1. We refer to the agreement dated [●] between you as the CfD Counterparty and us as the Generator (the “**Agreement**”). Terms and expressions defined in or incorporated into the Agreement have the same meaning when used in this notice.
2. We further refer you to Condition 30.4 of the Conditions (as inserted pursuant to Clause 6.3 of the Agreement).
3. This is a Loss of Route to Market Notice.
4. We hereby give you notice that as of [date] we no longer have a Route to Market.
5. We enclose the following Supporting Information as evidence: [●]
6. We enclose a Directors’ Certificate in relation to the information contained in, and enclosed with, this notice.

Yours faithfully,

.....

For and on behalf of
the **Generator**

(Route to Market Remediation Notice)

To: **[●]** (the “CfD Counterparty”)
[Address]

From: **[●]** (the “Generator”)
[Unique reference number: [●]]

Dated: **[●]**

CONTRACT FOR DIFFERENCE – ROUTE TO MARKET REMEDIATION NOTICE

Dear Sirs,

1. We refer to the agreement dated **[●]** between you as the CfD Counterparty and us as the Generator (the “**Agreement**”). Terms and expressions defined in or incorporated into the Agreement have the same meaning when used in this notice.
2. We further refer you to Condition 30.5 of the Conditions (as inserted pursuant to Clause 6.3 of the Agreement).
3. This is a Route to Market Remediation Notice.
4. We hereby give you notice that we have entered into a *[Grid Connection Agreement dated **[date]** with **[name of Licensed Distributor]** and confirm that all sums payable upon entry in the Grid Connection Agreement have been paid] [Market Supply Agreement with an Onsite Customer dated **[date]** and that Onsite Customer is **[name of Onsite Customer]**].*
5. We enclose the following Supporting Information:
 - [(A) a duly executed copy of the Grid Agreement;] [and]*
 - (B) [where the Facility does not have direct access to the Grid Connection, a duly executed copy of the Private Network Use Agreement]*
 - [(A) a duly executed copy of the Market Supply Agreement with the Onsite Customer].*
6. We enclose a Directors’ Certificate in relation to the information contained in, and enclosed with, this notice.

Yours faithfully,

.....

For and on behalf of
 the **Generator**

(Generator Metering Breach Notice)

To: [●] (the “CfD Counterparty”)
[Unique reference number: [●]]

From: [●] (the “Generator”)
[Address]

Dated: [●]

CONTRACT FOR DIFFERENCE – GENERATOR METERING BREACH NOTICE

Dear Sirs,

1. We refer to the agreement dated [●] between you as the CfD Counterparty and us as the Generator (the “**Agreement**”). Terms and expressions defined in or incorporated into the Agreement have the same meaning when used in this notice.
2. We further refer you to Condition 31.5 of the Conditions (as inserted pursuant to Clause 8.1 of the Agreement).
3. This is a Generator Metering Breach Notice.
4. We have identified [a] breach[es] of the following Metering Compliance Obligation[s]: [●].
5. The breach relates to [insert description of breach identified].
6. We enclose a Metering Remediation Plan.

Yours faithfully,

.....

For and on behalf of
the **Generator**

(Metering Remediation Plan)

To: [●] (the “CfD Counterparty”)
[Address]

From: [●] (the “Generator”)
[Unique reference number: [●]]

Dated: [●]

CONTRACT FOR DIFFERENCE – METERING REMEDIATION PLAN

Dear Sirs,

1. We refer to the agreement dated [●] between you as the CfD Counterparty and us as the Generator (the “**Agreement**”). Terms and expressions defined in or incorporated into the Agreement have the same meaning when used in this notice.
2. We further refer you to Condition [31.5 and] 31.7 of the Conditions [and to the Metering Response Notice dated [●]] [and to the Generator Metering Breach Notice which accompanies this Metering Remediation Plan].⁴⁵
3. This is a Metering Remediation Plan.
4. The breach to which this Metering Remediation Plan relates is [insert description of breach identified].
5. The proposed Metering Remediation Plan to remedy the breach is set out below.

Description of breach	[●]
Action to be taken to remedy breach	[●]
Target date for completion of remediation	[●]
Milestones	[●]
Responsibility for completing actions	[●]

Yours faithfully,

.....

For and on behalf of
the **Generator**

⁴⁵ Drafting note: To be included unless the Generator has self-reported the breach.

(Electrical Schematic Obligation Notice)

To: **[●]** (the “CfD Counterparty”)
[Address]

From: **[●]** (the “Generator”)
[Unique reference number: [●]]

Dated: **[●]**

CONTRACT FOR DIFFERENCE – ELECTRICAL SCHEMATIC OBLIGATION NOTICE

Dear Sirs,

1. We refer to the agreement dated **[●]** between you as the Generator and us as the CfD Counterparty (the “**Agreement**”). Terms and expressions defined in or incorporated into the Agreement have the same meaning when used in this notice.
2. We further refer you to Condition 31.12(A) of the Conditions (as inserted pursuant to Clause 8.1 of the Agreement).
3. This is an Electrical Schematic Obligation Notice.
4. We have identified a Material Change to the Facility Metering Equipment: **[insert reasons for and details of the Material Change].**
5. This Material Change occurred on **[insert date Material Change occurred].**
6. The old Meter Serial Number is **[insert old Meter Serial Number]** and the new Meter Serial Number is **[insert new Meter Serial Number].**
7. **[We enclose an updated version of the electrical schematic diagram referred to in paragraph 2.1(D) of Part B of Schedule 1 of the Conditions].**

Yours faithfully,

.....

For and on behalf of
the **Generator**

(Metering Access Contact Information)

To: [●] (the “CfD Counterparty”)
[Address]

From: [●] (the “Generator”)
[Unique reference number: [●]]

Dated: [●]

CONTRACT FOR DIFFERENCE – METERING ACCESS CONTACT INFORMATION

Dear Sirs,

1. We refer to the agreement dated [●] between you as the CfD Counterparty and us as the Generator (the “**Agreement**”). Terms and expressions defined in or incorporated into the Agreement have the same meaning when used in this notice.
2. We further refer you to paragraph 2.5 of Part B (*Further Conditions Precedent*) of Schedule 1 (*Conditions Precedent*) to the Conditions (as inserted pursuant to Clause 9.5 of the Agreement).
3. This is the Metering Access Contact Information.
4. The Metering Access Contact Information is as follows:

<i>Name</i>	[●]
<i>Position</i>	[●]
<i>Relationship to the Generator</i>	[●]
<i>Primary contact numbers</i>	<i>Landline number: [●]</i>
	<i>Mobile number: [●]</i>
<i>Secondary contact number</i>	[●]
<i>Email address</i>	[●]

Yours faithfully,

.....

For and on behalf of
the **Generator**

EXECUTION PAGE

The GENERATOR

SIGNED BY)
)
)

.....

.....

Print Name
for and on behalf of
[*name of the Generator*]

(Signature of named signatory)

The CfD COUNTERPARTY

SIGNED BY)
)
)

.....

.....

Print Name
for and on behalf of
**Low Carbon Contracts
Company Ltd**

(Signature of named signatory)