



**CONDITIONS OF RELEASE**

- 1 This information is released by the UK Government for Defence purposes only.
- 2 This information must be afforded the same degree of protection as that afforded to information of an equivalent security marking originated by the recipient Government or as required by the recipient Government's security regulations.
- 3 This information may be disclosed only within the Defence Department of the recipient Government, except as otherwise authorized by the Ministry of Defence (Army).
- 4 This information may be subject to privately owned rights.

**TRUCK UTILITY MEDIUM  
(HEAVY DUTY),  
6X6 PPV VECTOR**

**MAINTENANCE SCHEDULE  
(JOINT SERVICE)**

~~THIS DOCUMENT IS THE PROPERTY OF HER BRITANNIC MAJESTY'S GOVERNMENT, and is issued for the information of such persons only as need to know its contents in the course of their official duties. Any person finding this document should hand it to a British forces unit or to a police station for its safe return to the MINISTRY OF DEFENCE (Dsy (Pol)), MAIN BUILDING, WHITEHALL, LONDON SW1A 2HB with particulars of how and where found. THE UNAUTHORIZED RETENTION OR DESTRUCTION OF THIS DOCUMENT MAY BE AN OFFENCE UNDER THE OFFICIAL SECRETS ACTS OF 1911-1989. (When released to persons outside Government service, this document is issued on a personal basis and the recipient to whom it may be entrusted in confidence, within the provision of the Official Secrets Acts 1911-1989, is personally responsible for its safe custody and for seeing that its contents are disclosed only to authorised persons).~~

**BY COMMAND OF THE DEFENCE COUNCIL**

Ministry of Defence  
Issued by

**DEFENCE LOGISTICS ORGANISATION**

UK-RESTRICTED

UK-RESTRICTED

AMENDMENT RECORD

Amdt No.	Incorporated By (Signature)	Date
1	BAE Systems Land Systems Pinzgauer Limited	Apr 07
2	BAE Systems Land Systems Pinzgauer Limited	Aug 07
3	BAE Systems Land Systems Pinzgauer Limited	Nov 07
4	BAE Systems Land Systems Pinzgauer Limited	Dec 07
5	BAE Systems Land Systems Pinzgauer Limited	Sep 08
6	BAE Systems Land Systems Pinzgauer Limited	Sep 09
7	Incorporated	Dec 12
8		
9		
10		
11		
12		
13		
14		
15		
16		
17		
18		
19		
20		
21		
22		
23		
24		
25		
26		
27		
28		
29		
30		
31		

Amdt No.	Incorporated By (Signature)	Date
32		
33		
34		
35		
36		
37		
38		
39		
40		
41		
42		
43		
44		
45		
46		
47		
48		
49		
50		
51		
52		
53		
54		
55		
56		
57		
58		
59		
60		
61		
62		

UK RESTRICTED

UK RESTRICTED

**CONTENTS**

**PRELIMINARY MATERIAL**

	Page
Title page.....	(i)/(ii)
Amendment record.....	(iii)/(iv)
Contents (this list).....	(v)
PREFACE.....	(vi)
Introduction.....	(vi)
Equipment identity.....	(vi)
Related and associated publications.....	(vii)
Related publications.....	(vii)
Associated publications.....	(viii)
Comment on AESP.....	Final leaf

**MAINTENANCE INSTRUCTIONS**

Chapter

1	Maintenance schedule	
1-1	Truck Utility Medium (Heavy Duty) 6x6 PPV VECTOR all variants	

## PREFACE

Sponsor : DEC GM  
Publications Authority: DE & S

## INTRODUCTION

1 Service users should forward any comments on this publication through the channels prescribed in AESP 0100-P-011-013. An AESP Form 10 is provided after the preliminary pages of this publication; it should be photocopied and used for forwarding comments on this AESP.

2 AESPs are issued under Defence Council authority and where AESPs specify action to be taken, the AESP will of itself be sufficient authority for such action and also for the demanding of the necessary stores, subject to the provisions of Para 3 below.

3 The subject matter of this publication may be affected by Defence Council Instructions (DCIs), by Standing Operating Procedures (SOPs) or by local regulations. When any such Instruction, Order or regulation contradicts any portion of this publication it is to be taken as the overriding authority.

4 The subject matter of this publication details information specific to Truck Utility Medium (Heavy Duty) 6x6 PPV VECTOR Pinzgauer all variants.

5 For periods of servicing and lubricants to be used reference must be made to the Maintenance Schedule.

## EQUIPMENT IDENTITY

6 The details are listed in Table 1

TABLE 1 EQUIPMENT IDENTITY

Serial (1)	Asset Code (2)	Designation (3)	UCE/ UCA
1	NB1774 3100	Truck Utility Medium (Heavy Duty) 6X6 PPV (VECTOR-1)	A
2	NB1045 3100	Truck Utility Medium (Heavy Duty) 6X6 PPV (VECTOR-2)	B
3	NB1045 3100	Ambulance Protected TUM (HD) 1 Stretcher 6x6 2.5 LTR DSL (VECTOR-1)	C
4	NB1045 3101	Ambulance Protected TUM (HD) 1 Stretcher 6x6 2.5 LTR DSL (VECTOR-2)	D
5	NB1785 3100	Truck Utility Medium (Heavy Duty) 6X6 PPV (VECTOR-2) WATCHKEEPER	

6.1 The Original Equipment Manufacturer (OEM) is as follows:

BAE Systems  
Combat Vehicles UK  
Hadley Castle Works  
PO Box 106  
Telford  
Shropshire  
TF1 6QW

[www.baesystems.com](http://www.baesystems.com)

6.2 Contract Nos:

SUVC1/0077

**RELATED AND ASSOCIATED PUBLICATIONS**

**Related publications**

7 The Octad for the subject equipment consists of the publications shown opposite. All are prefixed with the first eight digits of this publication. The availability of the publications can be checked by reference to the relevant Group Index (see AESP 0100-A-001-013).

Category/Sub-category			Information Level			
			1 User/ Operator	2 Unit Maintenance	3 Field Maintenance	4 Base Maintenance
1	0	Purpose and Planning	101	101	101	101
	1	Equipment Support Policy Directives	111	111	111	111
2	0	Operating Information	201	201	201	201
	1	Aide Memoire	211	211	211	211
	2	Training Aids	*	*	*	*
3		Technical Description	*	302	302	302
4	1	Installation Instructions	411	411	411	411
	2	Preparation for Special Environments	*	*	*	*
5	1	Failure Diagnosis	*	512	512	512
	2	Maintenance Instructions	201	522	522	522
	3	Inspection Standards	*	532	532	532
	4	Calibration Procedures	*	*	*	*
6		Maintenance Schedules	601	601	601	601
7	1	Illustrated Parts Catalogue	711	711	711	711
	2	Commercial Parts List	*	*	*	*
	3	Complete Equipment Schedule, Production	*	*	*	*
	4	Complete Equipment Schedule, Service Edition (Simple Equipment)	741	741	741	741
	5	Complete Equipment Schedule, Service Edition (Complex Equipment)	*	*	*	*
8	1	Modification Instructions	811	811	811	811
	2	General Instructions, Special Technical Instructions and Servicing Instructions	821	821	821	821
	3	Service Engineered Modification Instructions (RAF only)	*	*	*	*

\* Category/Sub-category not published

**NOTES**

- (1) Reference to AESP 0100-A-001-013 must be made to ensure the availability of the listed publications.
- (2) Category 8 preliminary pages to be issued with the first Modification or General Instruction.

**Associated publications**

8	<u>Reference</u>	<u>Title</u>
	JSP 800 (E)	Defence Movements and Transportation Regulations Volume 5 Road Transport
	AESP 2300-A-050-013	'B' Vehicle Maintenance, Inspection, Test and Certification
	AESP 2300-A-401-013	Short Term Storage, All Vehicles
	AP1269	Manual of Medical Management and Administration
	AESP 2540-A-100-201	Pintle, Towing Rotatable, (All Capacities)



**COMMENT(S) ON AESP\***

To: DCCS  
BFPO 794

From: .....  
.....  
.....  
.....

<b>Sender's Reference</b>	<b>BIN Number</b>	<b>Date</b>
<b>AESP* Title:</b>		
<b>Chapter(s)/Instruction</b>	<b>Page(s)/Paragraph(s)</b>	
If you require more space, please use the reverse of this form or a separate piece of paper. <b>Comment(s):</b>		

Signed: ..... Telephone No.: .....  
Name (Capitals): ..... Rank/Grade: ..... Date: .....  
✂ .....

**FOR AESP\* SPONSOR USE ONLY**

To: ..... From: DCCS  
..... BFPO 794  
.....  
.....

Thank you for commenting on AESP\*: .....  
Your reference: ..... Dated: .....

<b>Action is being taken to:</b>	<b>Tick</b>	<b>Tick</b>
Issue a revised/amended AESP*		Under investigation
Incorporate comment(s) in future amendments		No action required
<b>Remarks</b>		

Signed: ..... Telephone No.: .....  
Name (Capitals): ..... Rank/Grade: ..... Date: .....  
\* AESP or EMER

**UK-RESTRICTED**

**UK-RESTRICTED**

**CHAPTER 1**

**MAINTENANCE SCHEDULE**

**CONTENTS**

Para

- 1 Introduction
- 7 Definitions
- 8 Warnings, cautions and maintenance notes
- 9 Maintenance intervals and areas of responsibility

## INTRODUCTION

1 This Maintenance Schedule is the authority for carrying out all scheduled maintenance tasks on the subject equipment and takes precedence over any other conflicting publication.

2 The Unit Commander (Army) or Mechanical Transport (MT) Officer (RAF) is responsible for ensuring that the operations detailed in this Maintenance Schedule are properly carried out by appropriately qualified and trained personnel or, where annotated, a Qualified Tradesman (QT) (Army only). These personnel are defined as:

2.1 A REME Vehicle Mechanic (VM).

2.2 Any person who has been formally trained as a Driver/Operator Mechanic on the subject equipment type - (Army only).

2.3 Any person who has been taught how to carry out that task during a formal training course.

2.4 A civilian equivalent of the above.

3 The Unit Commander (Army) or MT Officer (RAF) may order any operation to be carried out more frequently than is specified if the conditions under which the equipment operates render it necessary. For Army equipment the Senior Maintenance Advisor should be consulted.

4 Scheduled Maintenance is to be recorded in the appropriate equipment document in accordance with JSP 800 (E) Vol 5.

5 Serial numbers left blank in the tables may be taken up by amendment action at a later date.

6 The following maintenance schedules are provided:

6.1 Chapter 1-1 Truck Utility Medium (Heavy Duty) 6X6 PPV VECTOR all variants

## DEFINITIONS

7 As far as this document is concerned, the following definitions apply:

7.1 Examine. Carry out a survey of the condition of an item without dismantling, **unless** specifically instructed to do so in the relevant task requirement. The condition of an item may be impaired by the following:

7.1.1 Insecurity of attachment.

7.1.2 Cracks or fractures.

7.1.3 Corrosion, contamination or deterioration.

7.1.4 Distortion.

7.1.5 Loose or missing fasteners.

7.1.6 Chafing, fraying, scoring or wear.

7.1.7 Faulty or broken locking devices.

7.1.8 Loose clips or packing, obstruction of, or leakage from pipelines.

7.1.9 Discoloration due to overheating or leakage of fluids.

7.1.10 Damage due to external sources.

7.2 Check. Make a comparison of measurement of time, pressure, temperature, resistance, dimension or other quantity, with a known figure.

7.3 Operate. As far as possible, ascertain that a component or system functions correctly without the use of test equipment or reference to measurement.

7.4 Replenish. Refill a container to a predetermined level, pressure or quantity. This includes any necessary cleaning of orifices, examination of caps, covers, gaskets and washers, renewal of locking devices and clearing of vents.

7.5 Replace. Remove an item and then fit a new or reconditioned item.

### WARNINGS, CAUTIONS AND MAINTENANCE NOTES

8 Before any maintenance task is carried out, the WARNINGS, CAUTIONS and Maintenance Notes preceding the appropriate table must be read and understood.

### MAINTENANCE INTERVALS AND AREAS OF RESPONSIBILITY

9 Table 4 - Action on Receipt. The maintenance detailed in Table 4 covers the action taken when the equipment arrives in a unit. These operations will normally be of a once only nature, eg the recording of lifting equipment with the appropriate test authority, actions that are necessary to be undertaken before the equipment is put into service or actions that are only required during the running in period. The maintenance detailed in Table 4 maintenance must be carried out by appropriately trained personnel, as described in Para 2.

10 Table 5 - Out of Phase Maintenance. The maintenance detailed in Table 5 covers tasks that do not fall into line with the time/usage interval requirements of Table 6 or 7. The maintenance detailed in Table 5 maintenance must be carried out by appropriately trained personnel, as described in Para 2.

11 Table 6 - Driver/Operator Maintenance. The maintenance detailed in Table 6, Maintenance Intervals A, B, C and D must be carried out by appropriately trained personnel, as described in Para 2.

- 11.1 A Daily before use (only on days used).
- 11.2 B Daily after use (after the equipment has been operated).
- 11.3 C Weekly, whether the equipment is used or not.
- 11.4 D Not applicable.

12 Table 7 - Time/Usage Maintenance. The maintenance detailed in Table 7, Maintenance Interval 1st, A, B, C and D must be carried out by appropriately trained personnel, as detailed in Para 2, at the following intervals:

- 12.1 1st (RAF Initial) - After the first 1,000 km.
- 12.2 A (RAF Lubrication) - Every 8,000 km or 6 months, whichever occurs first.
- 12.3 B (RAF Minor) - Every 16,000 km or 12 months, whichever occurs first.
- 12.4 C (RAF Major) - Not taken up, see out of phase maintenance.
- 12.5 D - Contains the Area Maintenance indicator which may be used, at the discretion of the MT Officer, to carry out Area Maintenance at the appropriate time/usage intervals (RAF only).

## NOTES (RAF ONLY)

(1) Vehicles that do less than 8000 km annually and are on Area Maintenance are to have a Lubrication Maintenance at 6 monthly intervals in accordance with AESP 2300-A-050-013.

(2) The number in Maintenance Interval D indicates which Area is to be carried out.

(3) The area maintenance detailed is to be carried out in conjunction with its associated prime mover/specialist equipment scheduled maintenance if applicable.

13 Table 8 - Out of Use Maintenance. For Army equipment, this maintenance is to be carried out as follows:

13.1 When the equipment is taken out of use for periods exceeding one month on the advice of the local Maintenance Advisor.

13.2 Any equipment taken out of use for periods exceeding four months is to be put into preservation in accordance with AESP 2300-A-401-Octad Short Term Storage All Vehicles.

13.3 The equipment is to be cleaned, dried and stored under cover where possible.

13.4 Any overdue maintenance is to be carried out when the equipment is brought back into use.

13.5 The maintenance detailed in Table 8 is to be carried out by appropriately trained personnel, as described in Para 2.

14 For RAF equipment, out of use vehicles or vehicles in second echelon are to be maintained in accordance with AESP 2300-A-050-013. Any specific operation appertaining to this equipment will be listed in Table 8 of this AESP.

**CHAPTER 1-1**

**MAINTENANCE SCHEDULE - TRUCK UTILITY MEDIUM (HEAVY DUTY)  
6X6 PPV VECTOR-1 AND VECTOR-2 (INCL AMBULANCE)**

**CONTENTS**

Para

- 1 Introduction
- 6 Definitions
- 7 Warnings, cautions and maintenance notes
- 8 Maintenance intervals and areas of responsibility

Table

1	Equipment applicability.....	2
2	Fuels, lubricants and associated products.....	3
3	Equipment data .....	4
4	Action on receipt.....	5
5	Out of phase maintenance .....	5
6	Driver/operator maintenance.....	6
7	Time/usage maintenance .....	10
8	Out of use maintenance .....	19

Fig

1	Lubrication diagram.....	21/22
---	--------------------------	-------

**INTRODUCTION**

1 This Maintenance Schedule is the authority for carrying out all scheduled maintenance tasks on the subject equipment (Truck Utility Medium (Heavy Duty) 6X6 PPV VECTOR-1 and VECTOR-2 (Incl AMBULANCE) and takes precedence over any other conflicting publication.

**DEFINITIONS**

2 Refer to Chapter 1.

**WARNINGS, CAUTIONS AND MAINTENANCE NOTES**

3 Before any maintenance task is carried out, the WARNINGS, CAUTIONS and Maintenance Notes preceding the appropriate table must be read and understood.

**MAINTENANCE INTERVALS AND AREAS OF RESPONSIBILITY**

4 Refer to Chapter 1.

TABLE 1 EQUIPMENT APPLICABILITY

Serial (1)	Equipment Asset Code (2)	Designation (3)	Contract Numbers (4)
1	NB 1774 3100	Truck Utility Medium (Heavy Duty) 6X6 PPV VECTOR-1	SUVC1/0077
2	NB 1774 3100	Truck Utility Medium (Heavy Duty) 6X6 PPV VECTOR-2	SUVC1/0077
3	NB 1045 3100	Ambulance Protected TUM (HD) 1 Stretcher 6x6 2.5 LTR DSL VECTOR-1	SUVC1/0077
4	NB 1045 3101	Ambulance Protected TUM (HD) 1 Stretcher 6x6 2.5 LTR DSL VECTOR-2	SUVC1/0077
5	NB 1785 3100	Truck Utility Medium (Heavy Duty) 6X6 PPV (VECTOR-2) WATCHKEEPER	SUVC1/0077



**TABLE 2 FUELS, LUBRICANTS AND ASSOCIATED PRODUCTS**

NOTES

- (1) The products listed below are to be used on this equipment. Alternative products must not be used without the approval of an appropriately qualified REME Advisor (Army) or MT Officer (RAF).
- (2) Oil changes at the -15 °C point shall only be made on the advice of the MT Officer.
- (3) The capacities listed are to be used as a guide only. A physical check is to be carried out to ensure that all fluid levels are correct. This check should be carried out with the vehicle unladen and standing on level ground whenever possible.

Serial (1)	Assembly (2)	Product		Capacity	
		Above -15 °C (3)	Below -15 °C (4)	Litres (5)	Pints (6)
1	Engine.	OMD 90	OMD 55	7.0	12.3
2	Engine coolant.	AL 39/water mixture		19.6	34.5
3	Gearbox oil circuit (automatic gearbox without draining torque converter).	OX 75	OX 75	6.0	10.5
4	Gearbox oil circuit (automatic gearbox with drained torque converter).	OX 75	OX 75	8.0	14.0
5	Axle drive - per drive.	OEP 220	OEP 220	2.0	3.5
6	Transfer transmission.	OEP 220	OEP 220	1.8	3.2
7	Steering gearbox.	OEP 220	OEP 220	0.7	1.2
8	Servo steering system.	OX 75	OX 75	2.75	4.8
9	Wheel drives:				
	9.1 Front.	OX 165	OX 165	0.4	0.7
	9.2 Rear.	OX 165	OX 165	0.35	0.6
10	Brake fluid reservoir.	OX 8	OX 8	0.6	1.1
11	Windscreen washer reservoir.	AL 11/washer fluid/ water mix		8.0	14.0
12	Fuel tank.	Dieso	Dieso	130	229
13	General greasing.	XG 279	XG 279	As required	As required
14	Hydraulic system.	OM 15	OM 15	15.0	26.4
15	Environmental control system (refrigerant).	R134a	R134a	0.8 kg	N/A
16	Environmental control system (oil).	PAG	PAG	0.3	0.5
17	Undersealing.	PX-28	PX-28	As required	As required

TABLE 3 EQUIPMENT DATA

Serial (1)	Item (2)	Detail (3)	
	<b>ADJUSTMENTS</b>		
1	Front wheel alignment.	Toe-in 3 to 5 mm	
2	Front hub swivel pin/bush wear limit.	0.35 mm	(0.014 in.)
	<b>TYRES</b>		
3	Size.	BF Goodrich 285/75 R 16 M/T	
4	Pressure.	In accordance with vehicle markings or: Front 4.5 bar, Rear 4.0 bar	
	<b>TORQUE SETTINGS</b>		
5	Wheel nuts.	260 Nm	(192 lbf ft)
6	Axle drive housing tie rods.	80 Nm	(59 lbf ft)
7	Axle clamping screws.	250 Nm	(185 lbf ft)
8	Axle centring screws.	250 Nm	(185 lbf ft)
9	Body bracket mounting bolts.	250 Nm	(185 lbf ft)
10	Retaining screw on brake floating calliper.	35 Nm	(26 lbf ft)
11	Engine oil drain plug.	50 Nm	(37 lbf ft)
12	Automatic gearbox drain-plug.	15 Nm	(11 lbf ft)
13	Seat-belt anchorage points.	35 Nm	(26 lbf ft)
14	Seat securing bolts	49 Nm	(36 lbf ft)

**TABLE 4 ACTION ON RECEIPT**

Serial (1)	Action (2)
1	Carry out an inspection in accordance with current regulation. Carry out the maintenance tasks from the Driver/Operator TABLE 6 column A.
2	On receipt of a vehicle from a source where the maintenance condition of the vehicle is unknown, carry out the maintenance tasks from the Driver/Operator Table 6 Column A, followed by the maintenance tasks from the Time/Usage Maintenance Table 7 Columns B, C, and Out of Phase Maintenance Table 5.
3	Check the torque loading of all wheel nuts.

**TABLE 5 OUT OF PHASE MAINTENANCE**

NOTES

- (1) Maintenance tasks bearing the trade task indicator Vehicle Mechanic (VM), must only be completed by an appropriately qualified person, as defined in Chap 1 Para 2. These tasks are not appropriate for completion by a Driver/Operator.
- (2) For EGR boost solenoid change procedure see AESP2320-D-503-522 Chapter 11.
- (3) The maintenance of the ambulance specialist medical equipment (maintenance tasks bearing the trade task indicator (ST) (Specialist Task)) is the responsibility of the Unit medical staff, and is to be carried out in accordance with AP1269 Lft 2-05 Station Services.

Serial (1)	Action (2)	Interval (3)
1	Replace coolant	36 months
2	Replace EGR boost solenoid filter (see note 1)	36 months
3	Replace toothed belt and toothed belt tensioner for camshaft - Record details in AB 562	Every 64,000 km or 48 months whichever occurs first.
4	Replace toothed injector pump belt and tensioning element - Record details in AB 562	Every 64,000 km or 48 months whichever occurs first.
5	Replace ribbed V (FEAD) belt and tensioning element	Every (64,000 km or 48 months whichever occurs first.
6	Replace brake fluid	24 months
7	Replace transfer gearbox oil	24 months
8	Replace axle drives oil	24 months
9	Replace Environmental Control System (ECS) drier	24 months
10	Replace Self Defence Weapon Mount bearings	24 months
11	Replace Self Defence Weapon Mount depression stop and cradle lock plunger pins	24 months
12	<b>Ambulance Variants Only:</b> Replace Oxygen / Air / Entonox Pipelines.(ST) (See note 3)	48 months
13	<b>Ambulance Variants Only:</b> Replace Terminal Outlet Assembly, Terminal Back Plate Seals, Terminal Main Seat Housing Seals, Nist Connection 'O' rings.(ST) (See note 3)	48 months

**TABLE 6 DRIVER/OPERATOR MAINTENANCE**

Driver/operator maintenance outlined in Table 6, is to be carried out by the tradesman and at the intervals shown at Chapter 1, Para 11. The following WARNINGS, CAUTIONS and Notes must be read and understood before commencing these maintenance tasks.

**WARNINGS**

- (4) **DANGER OF SCALDING. DO NOT REMOVE COOLANT FILLER CAP WHEN THE ENGINE IS HOT.**
- (5) **ACID SPLASH. EXERCISE CAUTION WHEN HANDLING BATTERIES.**
- (6) **TOXICITY. AL39 IS BOTH TOXIC AND HAZARDOUS. MINIMUM PRECAUTION AFTER CONTACT IS TO WASH THE AFFECTED AREA WITH SOAP AND WATER.**
- (7) **INFLAMMABLE LIQUID. AL11 IS HIGHLY INFLAMMABLE. THE PREPARATION OF THE FLUID FOR WINDSCREEN WASHERS IS TO BE CARRIED OUT IN THE OPEN AND AWAY FROM NAKED FLAME. MINIMUM PRECAUTION AFTER CONTACT IS TO WASH THE AFFECTED AREA WITH SOAP AND WATER.**
- (8) **PERSONAL INJURY. TO MAINTAIN THREAT INTEGRITY ENSURE THAT THE ENGINE COVER TOP PLATE IS ALWAYS RE-FITTED IN ACCORDANCE WITH THE PROCEDURE STATED IN AESP 2320-D-503-201 CHAPTER 4, USING ALL 14 OFF BOLTS.**

**CAUTIONS**

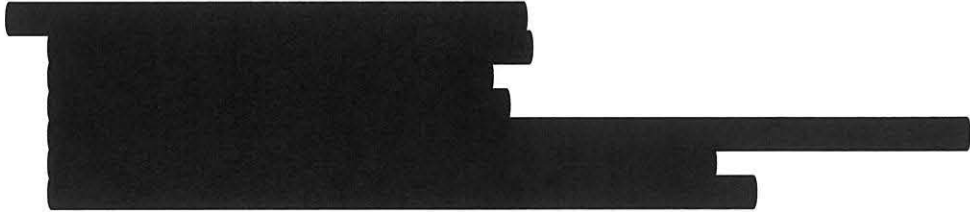
- (1) **MASTER SWITCH.** The battery master switch key can be removed when in the switched off position.
- (2) **EQUIPMENT DAMAGE.** After starting the engine, let it idle for ten seconds to allow oil to circulate through the turbo-charger bearings.
- (3) **EQUIPMENT DAMAGE.** Before switching off the engine, let it idle for two minutes to prevent damage to the turbo-charger bearings.
- (4) **EQUIPMENT DAMAGE.** Check oil level when engine is hot.
- (5) **WHEEL NUT TORQUE.** After changing a wheel retighten wheel nuts to 260 Nm after driving 30 miles (50 km).
- (6) **OIL INCOMPATIBILITY.** OX 75 and OX 165 oils used in servo steering and wheel drives are not compatible with other oils. Should they need to be changed the oil must be drained and flushed before refilling with a new type of oil.
- (7) 
- (8) **DAMAGE TO HYDRAULIC SYSTEM.** Do not use a high pressure hose on the hydraulic system

NOTES

(1) In-service coolant specific gravity meters may give a false reading when testing antifreeze other than that specified in Table 2, Serial 2. If there is any doubt as to the strength of the antifreeze mixture, then the system should be drained, flushed and refilled with AL 39 / Water mixture. (See also Table 5, Serial 1).

(2) Automatic gearbox oil level should be checked in accordance with the procedure detailed in AESP 2320-D-503-201 Chapter 4.

(3) The maintenance of the ambulance specialist medical equipment (maintenance tasks bearing the trade task indicator (ST) (Specialist Task)) is the responsibility of the Unit medical staff, and is to be carried out in accordance with AP1269 Lft 2-05 Station Services.

**TABLE 6 DRIVER/OPERATOR MAINTENANCE (continued)**

Serial (1)	Task (2)	Fig/ Item No. (3)	Product (4)	Maintenance interval			
				A (5)	B (6)	C (7)	D (8)
1	Examine vehicle for obvious signs of damage.			X	X		
2	Ensure that vehicle has sufficient engine and gearbox oil for the journey or task.	1/1,8		X			
3	Examine vehicle for fuel, oil or coolant leaks.			X	X		
4	Engine cover top plate. Examine for security of attachment. (See Warning 5)			X			
5	Cab interior and exterior: Examine for damage and security of attachment of panels, fasteners, interior trim and Barracuda.			X			
6	Seat-belts: Examine for serviceability and security of attachment.			X			
7	Doors and hatches: Examine and operate mechanism.			X			
8	Rear view mirrors: Examine for damage and security of attachment.			X	X		
9	Windscreen washer reservoir: Check level and replenish as necessary. (See Warning 4).		AL 11	X			
10	Lamps, horn, windscreen wipers and washers, directional indicators and hazard flashers, heaters and demisters, instruments and gauges: Examine and ensure correct operation.			X			
11	Warning lamps and buzzers: As far as practical ensure correct operation.			X			
12	Windscreen and windows: Examine for damage and cleanliness. (See Caution 7).			X			
13	Wiper arms and blades: Examine for serviceability.			X			

(continued)

TABLE 6 DRIVER/OPERATOR MAINTENANCE (continued)

Serial (1)	Task (2)	Fig/ Item No. (3)	Product (4)	Maintenance interval			
				A (5)	B (6)	C (7)	D (8)
14	Riot protection equipment: Examine for serviceability.			X			
15	Reflectors: Examine for damage, cleanliness and security of attachment.			X			
16	Registration plates, warning signs, instruction plates and other markings: Examine for damage, cleanliness and security of attachment.			X			
17	Fire extinguishers: Ensure vehicle is fitted with serviceable fire extinguishers.			X			
18	Battery: Examine terminals for security of attachment. (See Warning 2).			X			
19	Radiator matrix: Examine and clean as necessary.			X			
20	Brake reservoir: Check fluid level and replenish as necessary.	1/13	OX 8	X			
21	NTU						
22	Fuel filter: Drain.			X			
23	Tyre pressures: Check and adjust as necessary.			X			
24	Tyres: Examine for cuts, damage and uneven wear.			X			
25	NTU						
26	Road wheels (including spare wheel): Visually examine for damage and examine wheel bolt indicators for alignment and security of attachment. Replace missing indicators and check tightness of corresponding wheel bolts to the recommended torque loading. Retighten misaligned bolts to the recommended torque loading and re-attach the wheel bolt indicators as per Mod Ins No. 3.			X			
27	Loose equipment: Ensure items are stowed correctly.			X			
28	CES equipment: Examine for serviceability and correct stowage.			X			
29	Body and specialist fitments: Examine for serviceability and security of attachment.			X			
30	Electrical accessories: Examine and ensure correct operation.			X			

(continued)

**TABLE 6 DRIVER/OPERATOR MAINTENANCE (continued)**

Serial (1)	Task (2)	Fig/ Item No. (3)	Product (4)	Maintenance interval			
				A (5)	B (6)	C (7)	D (8)
31	Steering: Ensure correct operation.			X			
32	Brakes: Ensure correct operation.			X			
33	Towing pintle: Examine.			X			
34	Coolant: Check SG reading. (See Maintenance Note 1)		AL 39/Water mixture	X			
35	Hydraulic system: Check fluid level and replenish as necessary.	1/16	OM 15	X			
36	Hydraulic module louvers: Examine and clean as necessary. (See Caution 8).			X			
37	Cooler matrix and alternators (hydraulic module): Examine and clean as necessary. (See Caution 8).			X			
38	Hydraulic system filter: check blocked indicator			X			
39	Environmental Control System: Ensure louvers and vents are clear from obstructions and all visible components are secure and damage free.			X			
40	Armour system: Examine for serviceability			X			
41	Static functional test: Carry out to confirm the serviceability of all functions and particularly door locks, window regulators/catches, seat adjusters, seat belts and obligatory lights.			X			
	<b>AMBULANCE VARIANT</b>						
42	Body exterior: Check security of external stretcher stowage.			X			
43	Body interior: Specialist medical equipment. Check serviceability of all stowages / stowage straps and security of attachment of stowed items. (ST) (See Maintenance Note 3).			X			
44	Stretcher mechanism – Check operation, including locking devices.			X			
45	Interior lights – Check for correct operation.			X			
46	Exterior lights/red cross signs/siren – Check for correct operation/serviceability as applicable			X			
47	Oxygen/Entonox lines – Check for signs of damage, abrasion, leakage at joints, signs of deterioration and soiling. (ST) (See Maintenance Note 3).			X			

(continued)

TABLE 6 DRIVER/OPERATOR MAINTENANCE (continued)

Serial (1)	Task (2)	Fig/ Item No. (3)	Product (4)	Maintenance interval			
				A (5)	B (6)	C (7)	D (8)
	<b>GENERAL</b>						
48	Mobile functional test: Carry out to confirm the serviceability of all functions of starting, driving through the gears and stopping the vehicle.			X			
49	ADP 658/FMT658A/FMT1001/FMT1001A (Duty Movement Authorisation/Driver Tasking Sheet) as appropriate: Sign.			X			
50	Turn off vehicle battery isolator switches.				X		

TABLE 7 TIME/USAGE MAINTENANCE

Time/usage maintenance outlined in Table 7 is to be carried out by the tradesman and at the intervals shown at Chapter 1, Para 12. The following WARNINGS, CAUTIONS and Notes must be read and understood before commencing these maintenance tasks.

**WARNINGS**

- (1) **DANGER OF SCALDING. DO NOT REMOVE COOLANT FILLER CAP WHEN THE ENGINE IS HOT.**
- (2) **ACID SPLASH. EXERCISE CAUTION WHEN CHECKING BATTERY LEVELS.**
- (3) **TOXICITY. AL39 IS BOTH TOXIC AND HAZARDOUS. MINIMUM PRECAUTION AFTER CONTACT IS TO WASH THE AFFECTED AREA WITH SOAP AND WATER.**
- (4) **INFLAMMABLE LIQUID. AL11 IS HIGHLY INFLAMMABLE. THE PREPARATION OF THE FLUID FOR WINDSCREEN WASHERS IS TO BE CARRIED OUT IN THE OPEN AND AWAY FROM NAKED FLAME. MINIMUM PRECAUTION AFTER CONTACT IS TO WASH THE AFFECTED AREA WITH SOAP AND WATER.**
- (5) **PERSONAL INJURY. TO MAINTAIN THREAT INTEGRITY ENSURE THAT THE ENGINE COVER TOP PLATE IS ALWAYS RE-FITTED IN ACCORDANCE WITH THE PROCEDURE STATED IN AESP 2320-D-503-201 CHAPTER 4, USING ALL 14 OFF BOLTS.**

**CAUTIONS**

- (1) **MASTER SWITCH.** The battery master switch key can be removed when in the switched off position.
- (2) **EQUIPMENT DAMAGE.** After starting the engine, let it idle for ten seconds to allow oil to circulate through the turbo-charger bearings.
- (3) **EQUIPMENT DAMAGE.** Before switching off the engine, let it idle for two minutes to prevent damage to the turbo-charger bearings.
- (4) **EQUIPMENT DAMAGE.** Check oil level when engine is hot.
- (5) **WHEEL NUT TORQUE.** After changing a wheel retighten wheel nuts to 260 Nm after driving 30 miles (50 km).



(6) **OIL INCOMPATIBILITY.** OX 75 and OX 165 oils used in servo steering and wheel drives are not compatible with other oils. Should they need to be changed the oil must be drained and flushed before refilling with a new type of oil.

(7)

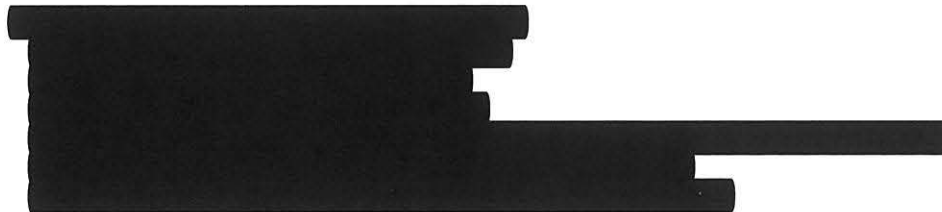

(8) **DAMAGE TO HYDRAULIC SYSTEM.** Do not use a high pressure hose on the hydraulic system.

#### NOTES

- (1) When pressure testing the coolant system, ensure that the heater valve is open.
- (2) With the ignition switched off, the transmission automatically selects all wheel drive so that the handbrake operates on all six wheels.
- (3) Minimum legal brake lining thickness is 2 mm. When changing brake pads, replacement of the ABS sensors and sensor bushes is also recommended.
- (4) Automatic gearbox oil level should be checked in accordance with the procedure detailed in AESP 2320-D-503-201 Chapter 4-4.
- (5) Steering gear and transmission components have combined filler/level plugs and are correctly filled when the oil is up to the oil filler opening.
- (6) In-service coolant specific gravity meters may give a false reading when testing antifreeze other than that specified in Table 2, Serial 2. If there is any doubt as to the strength of the antifreeze mixture, then the system should be drained, flushed and refilled with AL 39 / water mixture. (See also Table 5, Serial 1).
- (7) The majority of Time/Usage Maintenance tasks require the removal of the driver seat, passenger seat to permit the engine cover to be removed. Installation of the driver and passenger seats and engine cover (with the exception of the top plate) may only be performed by a qualified VM or equivalent.
- (8) As with all maintenance activities, the interval for Hydraulic System and ECS maintenance should, in particular, be performed more frequently if the conditions under which the equipment operates render it necessary e.g. when operating in a high sand/dust environment.
- (9) During air filter maintenance always check the pre-cleaner mounted on the roof of the vehicle. The pre-cleaner is self-exhausting, ensure the side vent outlet is clear from obstruction and there are no gaps between the pre-cleaner and downpipe. Also ensure that the outlet is orientated towards the rear of the vehicle and is not obstructed by the Barracuda camouflage system.
- (10) The maintenance of the ambulance specialist medical equipment (maintenance tasks bearing the trade task indicator (ST) (Specialist Task)) is the responsibility of the Unit medical staff, and is to be carried out in accordance with AP1269 Lfit 2-05 Station Services.

TABLE 7 TIME/USAGE MAINTENANCE (continued)

Serial (1)	Task (2)	Fig/ Item No. (3)	Product (4)	Maintenance interval				
				1st (5)	A (6)	B (7)	C (8)	D (9)
	<b>ENGINE</b>							
1	Engine: Examine for damage and particularly for oil and coolant leaks.	1/1		X	X	X		
2	Engine oil: Drain and replace.	1/1	OMD 90	X		X		
3	Engine oil filter: Replace.	1/3		X		X		
4	Air filter: Clean cartridge. (See Maintenance Note 9).				X			
5	Air filter: Replace cartridge. (See Maintenance Note 9).					X		
6	Fuel filter: Drain water from fuel filter.	1/4			X	X		
7	Fuel filter: Drain water from fuel/water separator.				X	X		
8	Fuel filter: Replace fuel filter	1/4				X		
9	Fuel tank, pipes and fittings: Examine, particularly for security of attachment and chafing.			X	X	X		
10	Fault memory codes: Interrogate fault code memories of all systems with diagnostic software.(VM)			X		X		
11	Ribbed V (FEAD) belt: Check condition, replace if required. (See Table 5).					X		
12	Toothed camshaft belt: Check condition, replace if required. (See Table 5).					X		
13	Toothed fuel injection pump belt: Injection pump drive belt Check condition, replace if required. (See Table 5)					X		
14	Coolant header tank: Examine, check coolant level and replenish as required.	1/2	AL39/ Water mix	X	X	X		
15	Cooling and lubrication systems: Check hoses and fittings for security of attachment and chafing.			X	X	X		
16	Coolant: Measure specific gravity. (See Maintenance Note 6).					X		
17	Exhaust and turbo-charger system: Examine for damage and leaks, check mountings for security of attachment.			X	X	X		
18	Electro magnetic fan clutch: Examine.					X		
19	Engine mountings: Examine for condition and security of attachment.			X	X	X		

(continued)

**TABLE 7 TIME/USAGE MAINTENANCE (continued)**

Serial (1)	Task (2)	Fig/ Item No. (3)	Product (4)	Maintenance interval				
				1st (5)	A (6)	B (7)	C (8)	D (9)
<b>STEERING AND SUSPENSION</b>								
20	Power steering reservoir: Check fluid levels and replenish as necessary.		OX 75	X	X	X		
21	Servo, steering pump and steering gear: Check oil level, replenish as necessary. (See Maintenance Note 5) (See Caution 6).	1/5	See Maint. Note 5	X	X	X		
22	Servo steering (joints at power piston): Lubricate.	1/6	XG 279		X	X		
23	Steering operating cylinders: Examine for leaks and security of attachment.			X	X	X		
24	Steering control linkages: Examine for damage, wear and security of attachment.			X	X	X		
25	Front wheel alignment: Check and adjust as necessary (VM).					X		
26	Steering wheel and column: Examine.					X		
27	Tyres: Examine for cuts, damage and uneven wear, replace as necessary.			X	X	X		
28	Tyre pressures (including spare wheel): Check and adjust as necessary.			X	X	X		
29	Wheel bolts: Check tightness of all wheel bolts to the recommended torque loading. Refit wheel bolt indicators as per Mod Ins No. 3.			X	X	X		
30	Shock absorbers: Examine for leaks and security of attachment.				X	X		
31	Steering gearbox: Check oil level, replenish as required.	1/7	OEP 220	X		X		
32	Leaf springs: Examine for security of attachment and condition of leaves and bushes.			X	X	X		
<b>TRANSMISSION</b>								
33	Gearbox, torque converter, transfer gearbox, wheel drives and axle drives: Check for leaks and security of attachment.			X	X	X		
34	Automatic gearbox: Drain and replenish automatic gearbox oil.	1/8	OX 75			X		
35	Automatic gearbox: Check oil level and replenish as necessary. (See Maintenance Notes 4 and 5).	1/8	OX 75	X		X		

(continued)

TABLE 7 TIME/USAGE MAINTENANCE (continued)

Serial (1)	Task (2)	Fig/ Item No. (3)	Product (4)	Maintenance interval				
				1st (5)	A (6)	B (7)	C (8)	D (9)
36	Transfer gearbox: Check oil level and replenish as necessary. (See Maintenance Note 5)	1/9	OEP 220	X		X		
37	Wheel drives: Check oil levels and replenish as necessary. (See Maintenance Note 5) and (See Caution note 6).	1/10	OX 165	X		X		
38	Axle drives: Check oil level and replenish as necessary. (See Maintenance Note 5).	1/11	OEP 220	X		X		
39	Propshaft: Examine.			X	X	X		
40	Propshaft: Lubricate.	1/12	XG 279	X		X		
41	Axle drive housing: Tighten tie rod to prescribed torque.			X		X		
42	Axle clamping screws: Tighten to prescribed torque loading.			X		X		
43	Axle centring screws: Tighten to prescribed torque loading.			X		X		
44	Front hub swivel pins and bushes: Examine particularly for excessive wear. (VM).			X		X		
45	Differential locks: Ensure correct operation. (VM).			X		X		
	<b>BRAKES</b>							
46	Connections and hoses: Examine for tightness and damage, secure or replace as necessary.			X	X	X		
46A	Brake fluid reservoir: Check fluid level, replenish if required. (See Table 5).	1/13	OX 8	X	X	X		
47	Brake callipers, discs and ABS sensors (where fitted): Examine for damage and security of attachment.			X	X	X		
48	Brake linings: Examine and replace if required. (See Maintenance Note 3).				X	X		
49	Handbrake: Check and adjust as necessary. (See Maintenance Note 2).				X	X		
50	Hand brake: Lubricate.		OMD 90		X	X		
51	Brake pedal and linkage: Lubricate.		OMD 90		X	X		
52	Brake system: Carry out brake test or decelerometer test. (In accordance with AESP 2300-A-050-013 (VM).					X		

(continued)

**TABLE 7 TIME/USAGE MAINTENANCE (continued)**

Serial (1)	Task (2)	Fig/ Item No. (3)	Product (4)	Maintenance interval				
				1st (5)	A (6)	B (7)	C (8)	D (9)
	<b>HYDRAULIC SYSTEM</b> (see Maintenance Note 8)							
53	Hydraulic system: Examine for damage and particularly for oil leaks. Check security of attachment.			X	X	X		
54	Hydraulic module louvers: Examine and clean as necessary. (See Caution 8).			X	X	X		
55	Cooler matrix and alternators (hydraulic module): Examine and clean as necessary. (See Caution 8).			X	X	X		
56	Hydraulic system filter: check blocked indicator, replace filter if required			X	X			
57	Hydraulic oil: Drain and replace.	1/16	OM 15			X		
58	Hydraulic oil filter: Replace.					X		
59	Boost filter: Replace.					X		
60	System breather: Replace							
61	Alternator/ECS compressor belts: Check condition, replace if required.			X	X			
62	Alternator/ECS compressor belts: Replace					X		
	<b>ELECTRICAL EQUIPMENT</b>							
63	Lamps, horn, windscreen wipers and washers, direction indicators and hazard flashers: Examine and ensure correct operation.			X	X	X		
64	Switches and warning devices: Examine and as far as reasonably practical ensure correct operation.			X	X	X		
65	Electrical wiring, junction boxes and conduits: Examine for signs of chafing, burning or other damage and for security of attachment.				X	X		
66	Fuses, fuse holders, circuit breakers and relays: Examine.				X	X		
67	Battery isolate switches: Examine and operate.				X	X		
68	Cold start device: Examine and operate.				X	X		
69	Heaters and demisters: Examine and operate.				X	X		
70	Electrical accessories: Examine and operate.				X	X		

(continued)

TABLE 7 TIME/USAGE MAINTENANCE (continued)

Serial (1)	Task (2)	Fig/ Item No. (3)	Product (4)	Maintenance interval				
				1st (5)	A (6)	B (7)	C (8)	D (9)
71	Instruments, gauges and transmitters: Examine and ensure correct operation.				X	X		
72	Wiper arms and blades: Examine for serviceability.			X	X	X		
73	Windscreen washer fluid reservoir: Check level and replenish as necessary.		AL 11	X	X	X		
74	Batteries: Examine terminals for security of attachment and apply protective lubricant.				X	X		
75	Battery stowage area: Examine, restore surface finish as necessary.				X	X		
76	Starter motor: Examine.				X	X		
77	Alternator: Examine.					X		
78	Headlight alignment: Check and adjust as necessary. (VM).					X		
79	Earth bonds: Examine/spot check.				X	X		
80	Ferrites: Examine				X	X		
	<b>ENVIRONMENTAL CONTROL SYSTEM (ECS)</b> (see Maintenance Note 8)							
81	System: Check security of attachment, inspect fittings, hoses, wiring, connections etc			X	X	X		
82	Louvers and vents: Examine and clear from obstructions. Remove sand/debris from around the system			X	X	X		
83	System: Examine for damage and particularly for leaks (Check for leaks with a U-V detector).			X	X	X		
84	Fans: Check fans are free to rotate.			X	X	X		
85	Sight glass: Check condition of sight glass (on drier)			X	X	X		
86	Compressor: Check for excessive noise from compressor			X	X	X		
87	Compressor: Check mounting bracket fixings			X	X	X		
88	Condenser: Clean coils (leaves and dirt)			X	X	X		
89	Condenser: Inspect coils for damage			X	X	X		
90	Evaporator: Clean coils			X	X	X		
91	Evaporator: Inspect coils for damage			X	X	X		

(continued)

**TABLE 7 TIME/USAGE MAINTENANCE (continued)**

Serial (1)	Task (2)	Fig/ Item No. (3)	Product (4)	Maintenance interval				
				1st (5)	A (6)	B (7)	C (8)	D (9)
92	Evaporator: Inspect drain hoses for blockages			X	X	X		
93	Drier: Inspect drier for refrigerant charge level			X	X	X		
<b>BODY AND CHASSIS</b>								
94	Cab and bodywork: Examine particularly for damage and corrosion.				X	X		
95	Windscreen and windows: Examine for damage and cleanliness. (See Caution 7).			X	X	X		
96	Mudguards: Examine.			X	X	X		
97	Cab doors and locks: Examine, ensure correct operation.			X	X	X		
98	Rear doors, locks and safety catches. Examine.			X	X	X		
99	Hatch, locks and safety catches. Examine.			X	X	X		
100	Rear step and side step assembly: Examine,			X	X	X		
101	Registration, marker and legal plates: Examine.			X	X	X		
102	Towing pins/hitches: Examine and lubricate.					X		
103	Vehicle body mounting brackets: Tighten to prescribed torque.					X		
104	Underseal: Examine and restore finish as necessary.		PX-28		X	X		
105	Seat adjuster: Examine, ensure correct operation and lubricate.		OMD 90			X		
106	Seat-belts: Examine, particularly for security of attachment.			X	X	X		
107	Seat-mounting (front seats): Examine, particularly for security of attachment (VM). (See Maintenance Note 7)					X		
108	Seat-mounting (rear compartment seats): Examine, particularly for security of attachment.					X		
109	Engine Cover: Examine, particularly for security and serviceability of engine cover blanket (See Warning 5)				X	X		
110	Armour system: Examine for serviceability.				X	X		

(continued)

TABLE 7 TIME/USAGE MAINTENANCE (continued)

Serial (1)	Task (2)	Fig/ Item No. (3)	Product (4)	Maintenance interval				
				1st (5)	A (6)	B (7)	C (8)	D (9)
111	Barracuda: Examine for damage and security of attachment of panels.				X	X		
112	Oilcan lubrication: General lubrication of all locks, hinges, catches, linkages and pins.		OMD 90	X	X	X		
113	Vehicle jack: Operate throughout its range on the vehicle for which it was issued. Hydraulic jacks are to be left at maximum height for five minutes then checked for creep.					X		
114	Specialist fitments: Examine for serviceability and security of attachment.				X	X		
<b>SELF DEFENCE WEAPON MOUNTS</b>								
115	Inspect for security of attachment			X	X	X		
116	Inspect for damage or corrosion. Rectify as necessary.			X	X	X		
117	Liberally oil all exposed metal surfaces and pins		OMD 90	X	X	X		
118	Check friction washers for thickness. Replace if less than 1.0 mm					X		
<b>AMBULANCE VARIANT</b>								
119	Body exterior: Check serviceability of external stretcher stowage.			X	X	X		
120	Body interior: Specialist medical equipment. Check serviceability of all stowages / stowage straps and security of attachment of stowed items. (ST) (See Maintenance Note 10).			X	X	X		
121	Stretcher mechanism – Check operation, including locking devices.			X	X	X		
122	Interior lights – Check for correct operation.			X	X	X		
123	Exterior lights/red cross signs/siren – Check for correct operation/serviceability as applicable			X	X	X		
124	Oxygen/Entonox lines – Check for signs of damage, abrasion, leakage at joints, signs of deterioration and soiling (ST) (See Maintenance Note 10).			X	X	X		
125	Body interior wall/side liner – Check condition and sealing of liners.				X	X		

(continued)



**TABLE 7 TIME/USAGE MAINTENANCE (continued)**

Serial (1)	Task (2)	Fig/ Item No. (3)	Product (4)	Maintenance interval				
				1st (5)	A (6)	B (7)	C (8)	D (9)
	<b>GENERAL</b>							
126	AF G1084A Worksheet or JAMES, Tradesman and countersigning NCO: Sign.			X	X	X		
127	Road-test (VM or NCO MT Technician): Carry out.			X	X	X		
128	Complete Form MT932W (VM)				X	X		
129	Complete Form MT932W (QT)				X	X		
130	Record action in FMT1004 or JAMES, Tradesman and countersigning NCO: Sign.			X	X	X		

**TABLE 8 OUT OF USE MAINTENANCE**

The out of use maintenance outlined in Table 8 is to be carried out in accordance with the instructions shown at Chap 1, Para 13. WARNINGS, CAUTIONS and Notes preceding Tables 6 and 7 must be read and understood before commencing these maintenance tasks.

**NOTE**

The Environmental Control System (ECS) should be turned on and used in cooling mode for 10-15 minutes every month. This ensures that oil is circulated around the system to lubricate the 'O' ring joints. It will be necessary to ensure that the ambient temperature inside the vehicle is at least 20°C which may require running the vehicle's heater for a period before activating the cool cycle.

Serial (1)	Operation (2)	Fig/ Item No. (3)	Product (4)
	<b>Prior to vehicle entering storage:</b>		
1	Carry out Table 6, Columns A, B and C maintenance, check coolant specific gravity and patch paint.		
2	Carry out next Table 7 maintenance due if it falls during out of use period.		
3	Rectify all faults affecting road/task worthiness.		
4	Fill fuel tanks.		
5	Isolate batteries using battery isolator switches and disconnect batteries.		
	<b>Ambulance Variant Only</b>		
6	Leave the cooling/heating and cooling/freezing box covers slightly open to prevent odour build up.		
7	AF G 1084A Worksheet and record action in FMT 1004 or JAMES, Tradesman and countersign NCO: Sign		

(continued)

**TABLE 8 OUT OF USE MAINTENANCE (continued)**

Serial (1)	Operation (2)	Fig/ Item No. (3)	Product (4)
	<b>Monthly while in storage (Periods less than 4 months):</b>		
8	Reconnect batteries and turn on battery isolator switches.		
9	Carry out walk-round inspection and start vehicle. Bring systems up to operating temperatures and pressures, then check for leaks.		
10	Operate equipment and all systems (see Note 1).		
11	Operate Environmental Control System (ECS) for 15 minutes in cooling mode.		
12	Carry out a road test over 8 Km (5 miles) if possible.		
13	Isolate batteries using battery isolator switches and disconnect batteries.		
14	Update FMT1004 or JAMES		
	<b>Action required to bring vehicle back into service:</b>		
15	Reconnect batteries and turn on battery isolator switches.		
16	Carry out Table 6, Columns A, B and C maintenance, check coolant specific gravity and patch paint		
17	Carry out Table 7 maintenance due.		
18	Carry out road test and examine for leaks.		
19	Carry out MT932 MEI if due, (VM).		
20	AF G 1084A Worksheet and record action in FMT1004 or JAMES. Tradesman and countersigning NCO: Sign		

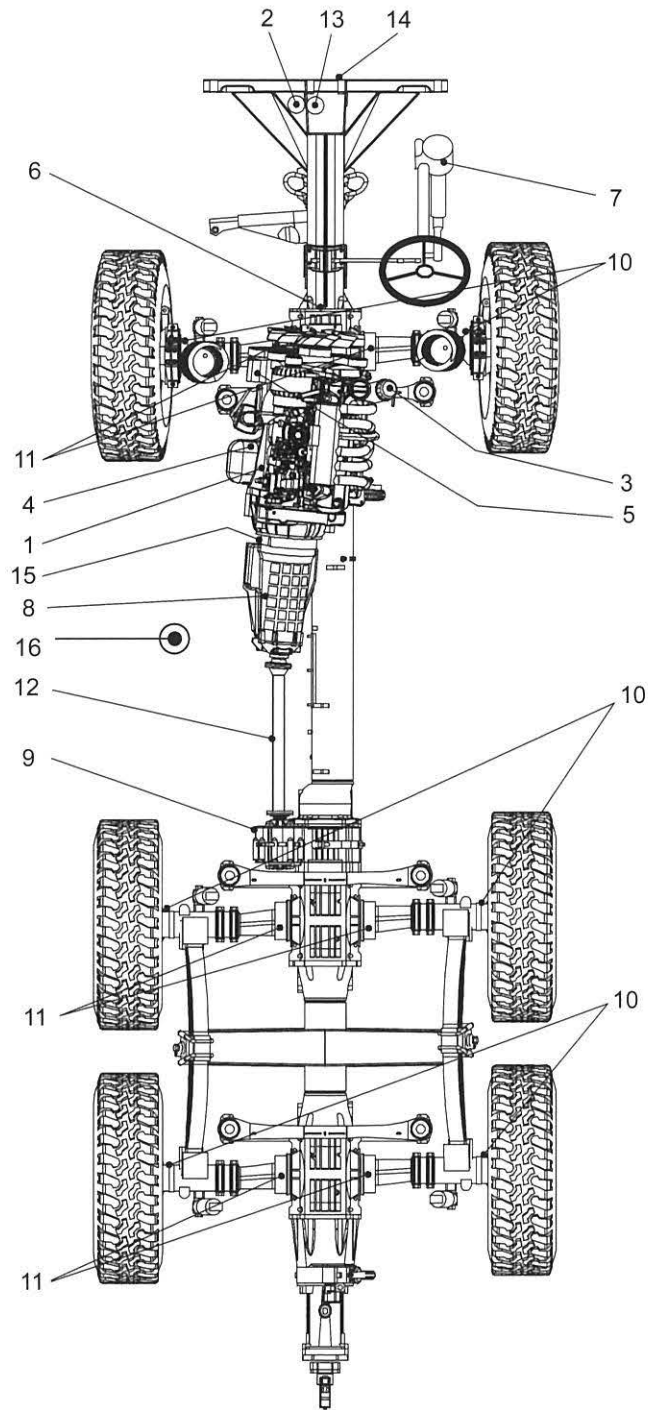

- |   |                       |    |                            |
|---|-----------------------|----|----------------------------|
| 1 | Engine                | 9  | Transfer gearbox           |
| 2 | Coolant header tank   | 10 | Wheel drives               |
| 3 | Oil filter            | 11 | Axle drives                |
| 4 | Fuel filter           | 12 | Propshaft                  |
| 5 | Servo steering pump   | 13 | Brake reservoir            |
| 6 | Servo steering joints | 14 | Winch (where fitted)       |
| 7 | Steering gearbox      | 15 | Power steering reservoir   |
| 8 | Gearbox               | 16 | Hydraulic system reservoir |

Fig 1 Lubrication diagram

UK-RESTRICTED

UK-RESTRICTED