

Environmental Permitting Regulations (England and Wales) 2010

enhancing... improving... cleaning... restoring...
changing... tackling... protecting... reducing...
creating a better place... influencing...
inspiring... advising... managing... adapting...

Regulatory Guidance Series, No EPR 2

Understanding the meaning of regulated facility

Appendix 3 – Interpretation of Intensive Farming Installations

Record of changes

| Version | Date | Change |
|---------|---------------|--|
| 1 | April 2006 | |
| 1.1 | June 2006 | Removal of scenario |
| 1.2 | October 2006 | Amendment of criteria for determining DAAs and applying the aggregation rule. |
| 2 | February 2012 | Updated to EPR |
| 3.0 | March 2013 | Updated for the Industrial Emissions Directive (IED) - changes introduced by EPR amendment SI 2013 No. 390 |
| 3.1 | May 2015 | Reviewed and re-issued – no changes required |
| | | |
| | | |

Published by:

Environment Agency
Horizon House, Deanery Road
Bristol BS1 5AH
Tel: 03708 506506
Email: enquiries@environment-agency.gov.uk
www.environment-agency.gov.uk

© Environment Agency 2015

All rights reserved. This document may be reproduced with prior permission of the Environment Agency.

A QUICK GUIDE

These appendices provide high level regulatory guidance on what activities are installations because they are listed in Schedule 1 of the Regulations. They should be read in conjunction with the main text of RGN 2

Generally installations are industrial, waste and intensive farming activities which must meet requirements of the Integrated Pollution Prevention and Control Directive.

A permit is required before any of these activities can be brought into operation, unless it is an existing operation being brought under the Regulations with transitional arrangements. Permit conditions will depend on the type of regulated facility and the risks posed to the environment.

If in doubt, operators should get our advice on detail, particularly before making an application for complex activities requiring a bespoke permit.

Contents

| | | |
|-----------|---|-----------|
| 1. | Definitions | 5 |
| 1.1 | Legislation and Guidance | 5 |
| 1.2 | Installation | 5 |
| 1.3 | Listed Activity | 6 |
| 1.4 | Aggregation of Capacities | 7 |
| 1.5 | Stationary Technical Unit (STU) | 10 |
| 1.6 | Directly Associated Activity (DAA) | 10 |
| 1.7 | The difference between 'Installation' and 'Site' | 12 |
| 1.8 | Operator | 12 |
| 1.9 | Capacity | 13 |
| 1.10 | Sensitive receptors | 14 |
| 2. | Scenarios to assist in defining an Intensive Farming Installation | 15 |
| 2.1 | A poultry farm consisting of four below-threshold groups of animal houses located around fields | 15 |
| 2.2 | A poultry farm consisting of two houses, each of which is above the threshold, where one is owned by the farmer and one by his wife | 15 |
| 2.3 | A duck farm consisting of four animal houses on the same site sharing some services | 16 |
| 2.4 | A mixed livestock farm consisting of 40,000+ poultry places and 1500 finishing pigs. | 17 |
| 2.5 | A pig farm consisting of three groups of animal houses on two sites sharing some services | 18 |
| 2.6 | A pig farm where pigs are sent outdoors for finishing | 19 |

| | | |
|-----------|---|-----------|
| 2.7 | A pig farm consisting of two separate animal houses, one containing finishers and the other containing weaners | 19 |
| 2.8 | Where the applicant is a holding company and the activity is to be carried out by a subsidiary company | 20 |
| 2.9 | Where the activity within an installation is to be carried out by contractors on behalf of an applicant company | 20 |
| 3. | Visual scenarios | 21 |

1. Definitions

1.1 Legislation and Guidance

The following legislation and guidance are referred to in this appendix.

- IED: The Industrial Emissions Directive (2010/75/EU), which comes into force between January 2013 and January 2016. The IED incorporates and supersedes the requirements of the IPPC Directive 2008/1/EC concerning integrated pollution prevention and control. The IPPC Directive will be repealed in January 2014.
- Core Guidance: Environmental Permitting Guidance, Core Guidance for the Environmental Permitting (England and Wales Regulations 2012)
- The Regulations: Environmental Permitting (England and Wales) Regulations 2010 SI 2010 No.675 (as amended¹)

1.2 Installation

Detailed guidance on the meaning of Regulated Facility and installation is provided in sections 2 and 3 of RGN 2 and Appendices 1 and 2. To summarise, an installation is :

1. a stationary technical unit (STU) where one or more Schedule 1 activities are carried out; and
2. any other location on the same site where a directly associated activity (DAA) is carried which:
 - (i) has a technical connection with the activities carried out in the STU;**and**
 - (ii) could have an effect on pollution.

It is an offence to operate an installation except under and to the extent authorised by an environmental permit.

Further guidance for intensive farming installations on the interpretation of Schedule 1 Activity, STU, same site and DAA is provided in the sections below.

¹ Environmental Permitting (England and Wales) (Amendment) Regulations 2010 SI 2010 No.676, the Environmental Permitting (England and Wales) (Amendment) (No. 2) Regulations SI 2010 No 2172; the Waste (England and Wales) Regulations 2011 SI No 988, the Environmental Permitting (England and Wales) (Amendment) Regulations SI 2012 No 630, the Environmental Permitting (England and Wales) (Amendment) Regulations SI 2013 No 390.X

1.3 Schedule 1 Activity

A farm which carries out one of the following activities, listed in Section 6.9 of Part 2 of Schedule 1 of the Regulations, will be an installation.

Rearing of poultry or pigs intensively in an installation with more than:

- (i) 40,000 places for poultry;
- (ii) 2,000 places for production pigs (over 30 kg); or
- (iii) 750 places for sows.

In this context:

“Poultry” means ‘fowl, turkeys, guinea fowl, ducks, geese, quails, pigeons, pheasants and partridges reared or kept in captivity for breeding, the production of meat or eggs for consumption or re-stocking supplies of game’. This is a broader definition than the one used in the IPPC Directive, which did not include pheasants and partridges for re-stocking supplies of game. Most game bird farms involve a combination of an exceptionally short season (typically some seven weeks in late spring/early summer), stocking densities that are significantly lower than any covered by animal welfare recommendations, and limited access to housing which is in nearly all cases only temporary in nature, making it unlikely that any significant environmental pollution would result. Consequently we will only regulate those game bird farms which are similar in nature (in terms of length rearing season, stocking density, and nature of housing) to the poultry farms we already regulate as Part A installations.

“Production pigs” are pigs, male or female, that weigh more than 30 kilogrammes. It includes gilts (female pigs) which are intended for breeding stock but **have not** been serviced.

“Sows” are female pigs that have had their first litter. It includes gilts (female pigs) that **have** been serviced but not yet had a litter.

Free-range poultry are included but pigs reared outdoors are excluded.

Other activities set out in Schedule 1 Part 2 that may take place alongside intensive farming activities include larger effluent treatment plants, incinerators and food processing plants.

Several different activities may be regulated under the same permit as long as they are carried out on the same site by the same operator.

Further guidance about activities can be found in RGN 2, Appendix 1.

1.4 Aggregation of Capacities

The IED provides that where one Operator carries out several activities falling under the same subheading in the same installation or on the same site, the capacities of those activities will be added together for the purpose of determining whether the listed activity threshold is met. This has been transposed into national legislation by paragraph 4(2) of Part 1 of Schedule 1 of the Regulations (the “aggregation rule”), which states:

“Where a person carries out several activities falling within the same description in Part A (1) or A (2) in different parts of the same stationary technical unit or in different stationary units on the same site, the capacities of each part or unit, as the case may be, must be added together and the total capacity must be attributed to each part or unit for determining whether the activity carried out in each part or unit falls within a description in Part A (1) or A (2).”

Paragraph 4(3) of Part 1 of Schedule 1 of the Regulations adds that for the purpose of the aggregation rule:

“no account must be taken of capacity when determining whether activities fall within the same description.”

It will not be necessary or appropriate to use the aggregation rule where it is clear that the activity carried out in a unit is above the threshold specified in Section 6.9 of Part 2 of Schedule 1 of the Regulations. Consequently, the aggregation rule will only be applied where one or more units are below the listed activity threshold and all the key requirements are met, namely:

- same activity;
- same site;
- same Operator.

For example, if two intensive poultry rearing units, each with a capacity of 30,000 places were operated on the same site, by the same Operator, the aggregate capacity would be 60,000 places and the relevant threshold of 40,000 places would be exceeded. The operator would require an environmental permit to continue to operate.

The expression “same site” which is found in the aggregation rule is not defined in either the IED or the Regulations. The issue of what constitutes same site for the purposes of the aggregation rule will be a question of fact in each case. When determining what constitutes the same site in a particular case, the Environment Agency will take into account all the circumstances, including the proximity of the various units and the degree of integration of operations. When assessing the degree of integration we shall consider factors such as the presence/absence of:

- permanent/historical farm boundaries;
- biosecurity restrictions;
- independent/integrated services;
- independent/integrated management systems.

If you are uncertain whether your activities should be aggregated, please contact your local Area office for advice.

An example to illustrate the application of the aggregation rule

Company X runs an egg laying business with units situated at three locations: Farm A, Farm B and Farm C. Farm B is located across a lane, 50m from Farm A and Farm C is directly adjacent to Farm B, with a distance of only 100m between the farm units. There is one unit at each Farm location: the unit at Farm A has 45,000 places, the unit at Farm B has 50,000 places and the unit at Farm C has 32,000 places. All three Farms are served by a chemical store situated at Farm B.

The activities at Farms A and B are over-threshold and will require an environmental permit. The activity at Farm C is under-threshold and will only be regarded as a Schedule 1 activity and require an environmental permit if it is brought into regulation by the aggregation rule.

In this scenario the aggregation rule will apply and the places at Farm C will be aggregated with those at Farm B: they have the same operator, carry out the same activity and will be regarded as being on the same site. As the cumulative number of places at the two units will be 82,000 Farm C will be subject to regulation.

It is then necessary to determine the extent of the installation(s) and the number of environmental permits required. The units at Farms A, B and C are each STUs in their own right. However, the units share a DAA, the chemical store, and as a result of their close proximity and integrated operation they will be regarded as being on the same site. In these circumstances, the STUs will be treated as one STU, there will be one installation (consisting of the STU and the DAA), and one permit will be required.

Even if the house at Farm B were to have only 10,000 places, the application of the aggregation rule would bring both Farm B and C within regulation, because the cumulative number of places would be 42,000 and both Farms would be regarded as carrying out a Schedule 1 activity. The decision in relation to the extent of the installation would be reached in the way described above.

If Farms A, B and C were to have only 15,000 places each, they would still be brought within regulation by the application of the aggregation rule. This is because they have the same operator, carry out the same activity and would be regarded as being on the same site by virtue of their integrated operation and close proximity. Again, the decision relating to the extent of the installation would be reached in the way described above.

If only Farms A and B were served by the chemical store, Farm C would be brought into regulation as a result of the operation of the aggregation rule, but the decision relating to the extent of the installation could be different. The absence of a shared DAA would mean that the unit at Farm C could be regarded as a separate installation. However, given that the Farms are regarded as being on the same site and have the same operator, the **two** installations (Farms A + B + DAAs and Farm C + DAAs) would be capable of regulation under **one** permit.

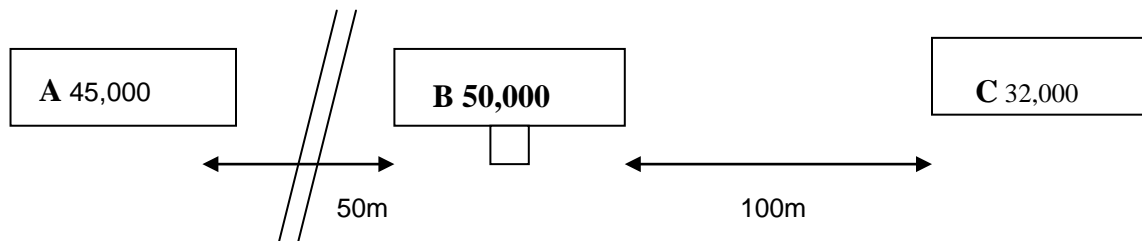

1.5 Stationary Technical Unit (STU)

A STU is the functionally self-contained plant or machinery that can carry out one or more Schedule 1 activities on its own. It must be stationary, and therefore vehicles and vessels in motion are excluded.

A unit (animal house) is an example of an intensive farming STU. In addition, movable free-range units that remain stationary during production periods are regarded as STUs.

If there are two or more STUs on the same site (see below) they will be treated as a single STU if they are technically connected and:

1. they carry out successive steps in an integrated industrial activity;
2. one of the listed activities is a DAA of the other; **or**
3. the STUs are served by the same DAA.

For example, where an operator has three 60,000-place poultry units which are all served by a shared feed mill, and the units and the feed mill are on the same site, the three units will be treated as one STU.

Further guidance on the definition of STU can be found in RGN2, Appendix 2.

1.6 Directly Associated Activity (DAA)

A DAA is an activity that takes place on the same site as the STU that meets **all** the following criteria:

1. it is directly associated with the STU, namely:
 - (i) it must be on the same site as the STU;
 - (ii) it must serve the STU; and
 - (iii) where it serves other units the STU must be the principal user (the **"principal user test"**);
2. it has a technical connection with the STU; and
3. it is capable of having an effect on pollution and emissions, either from the DAA itself or the STU.

An activity will be regarded as a DAA of an intensive farming activity if it involves the operation of a facility that serves one or more units and is on the same site. The expression "same site" in the context of DAAs is not defined in either the IPPC Directive or the Regulations. The issue of what constitutes same site will be a question of fact in each case. When determining what constitutes the same site in a particular case, the Environment Agency will take into account all the circumstances, including the proximity of the various units and the degree of integration of operations.. When assessing the degree of integration we shall consider factors such as the presence/absence of:

- permanent/historical farm boundaries;
- biosecurity restrictions;
- independent/integrated services;
- independent/integrated management systems.

To have an effect on pollution and emissions, an activity must have the potential to release dust, odour, noise, gases, liquids or solids to air, land or water in quantities that would have a significant impact. Therefore, although an egg packing plant would meet the other criteria, it would not usually be regarded as a DAA because such plants normally have little effect on pollution or emissions.

Links such as pipes and conveyor belts between a listed activity and a DAA will generally meet the 'technical connection' criterion, for example, a pipe to a slurry lagoon/tank that serves the STU. Operations conducted over short distances within the installation by wheeled transport, provided that the transport is essentially dedicated to those duties and effectively performs the function of pipework and conveyors, are also likely to be regarded as technically connected.

In practice, the DAAs commonly found at an intensive farming installation will include carcass incinerators, feed storage, feed mixing, and litter/slurry storage and handling facilities that are connected to houses either by fixed conveying systems or by wheeled transport. For example, the transport of slurry to a dedicated lagoon, or the delivery of feed to houses on site (either by a vehicle such as a tractor and trailer or by fixed pipework) may be DAAs. In practice, only a carcass incinerator would be listed as a DAA in the permit.

The following activities will **not** be regarded as DAAs:

- landspreading;
- the transport of manure from the installation to fields using a tractor and trailer;
- the transport from the installation through permanent or temporary pipework of slurry or dirty water used for irrigation;
- the provision of office and toilet facilities.

Where an activity serves both the STU and another unconnected unit, the STU must be the principal user of that activity for it to be a DAA. An example would be a slurry lagoon used by two independently operated farms, where farm A has 5000 pigs and farm B has only 200. If farm A were the principal user of the slurry lagoon, then it would be a DAA, but if farm B were the principal user it would not. Even if, on the basis of this test, the lagoon was not a DAA of farm A, any pipework between farm A and the lagoon would be included in the installation. In such a case the boundary of the installation would be the point where the pipe entered the lagoon.

Further guidance on what constitutes a DAA can be found in RGN2, Appendix 2..

1.7 The difference between 'Installation' and 'Site'

The site is the physical location where the listed and unlisted activities take place. In the intensive farming sector, the installation and the site are likely in most cases to be very similar in scope and area. The installation will include the livestock houses, effluent pipelines and other DAAs. The site will be the area covered by the installation, together with areas of land immediately adjacent to the installation where there is a reasonable chance of pollution by its activities. For example, narrow strips of land around each unit where ammonia-laden or feather dust-laden rain run-off might be deposited, and areas outside the main buildings that livestock might walk over or where deliveries of food or fuel might be made. The farm office and staff toilet blocks will not be included within the installation but may be within the site.

1.8 Operator

The Operator is the legal person (for example an individual, or a company) that has control over the operation of the installation. Effective regulation requires both an initial identification of the Operator and continued scrutiny to ensure that the Operator remains in control. A permit must not be granted if the Environment Agency considers that the applicant will not be the person with control over the operation of the installation.

Further guidance on the meaning of Operator can be found in our Regulatory Guidance Series, RGN 1 - Understanding the meaning of operator.

1.9 Capacity

The term “capacity” refers to the potential production of an installation rather than its actual historical production.

The capacity of an intensive farming installation is defined in terms of its potential ‘places.’ Agricultural installations, such as those that have laying hens, may make provision for a number of animals to be kept in separate small groups, in which case the number of places is a matter of simple arithmetic. Alternatively the installation may take the form of open plan units which could accommodate a variable number of animals. In such cases the number of places would, in the first instance, be determined by reference to the Defra Welfare Code requirements for stocking density for the livestock in question.

However, the potential Operator may have other limits on capacity that keep him below the threshold, such as the physical capacity of feeding stations for loose-housed sows or the need to meet assurance scheme requirements or comply with other health and welfare standards. In such a case, the potential Operator would need to demonstrate to the Environment Agency that these factors would prevent the facility from being operated at the Welfare Code stocking density. Undertakings alone will not be satisfactory; there will have to be sufficient evidence of restriction.

For example, an installation might theoretically have the capacity to keep livestock above the threshold but, in order to meet the requirements of an assurance scheme, the farmer may have to stock at a density below that in the Welfare Code and would never in practice exceed the threshold. In these circumstances the farmer would have to provide sufficient evidence of restriction, for instance, documents evidencing the actual stocking density e.g. flock records, Prima scheme records, supermarket codes of practice and assurance scheme requirements. In addition, the farmer should remove drinkers and feeding lines etc. so that places could not easily be re-commissioned.

Capacity relates to the number of animals that can be housed at the outset of the livestock activity, and is not affected by any attrition that might result in fewer animals surviving to the end of the rearing/production. In addition, the number of animals cannot be averaged over a year, and it is not material that numbers may dip below the threshold or the site may not be fully stocked for part of the year. It should be noted that exceeding the threshold limit at any time, even temporarily, without an environmental permit is an offence under the Regulations.

Where an Operator has an environmental permit, exceeding the permitted capacity is also an offence under the Regulations.

Where there is any uncertainty about capacity, potential Operators should contact the Environment Agency as soon as possible.

Further guidance on the meaning of capacity can be found in RGN2, Appendix 1.

1.10 Sensitive receptors

Distances to sensitive receptors are to be measured from the closest practicable point from where an emission may come, in other words, the source. A circle should be drawn on a map to illustrate distances of 400m and 2km from the site of the installation. In relation to the impacts from ammonia, odour and noise, where the installation comprises several separate units this may result in several circles being drawn. Sensitive receptors include residential housing, schools, workplaces, and ecological habitats such as Sites of Special Scientific Interest (SSSIs).

2. Intensive Farming Installation Scenarios

Below are a series of possible scenarios that represent different farm arrangements, together with comments as to whether an environmental permit is required and the reasoning behind each decision.

2.1 A poultry farm consisting of four below-threshold groups of animal houses located around fields

A poultry farm has grown over the years from one animal house to four groups of animal houses, located around fields. Each group houses 20,000 birds.

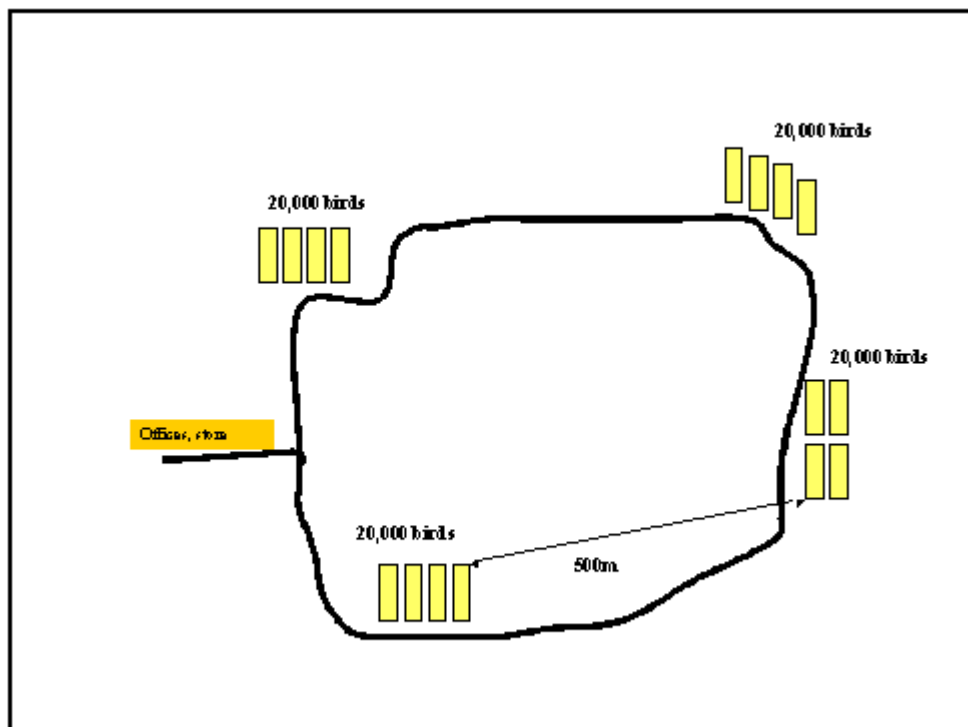

Comment: Although each group of animal houses is below the threshold, the groups share the same Operator and have common management systems and shared services. As a result they are considered to be on the same site. Therefore, their capacities will be aggregated together, with ONE permit being required.

2.2 A poultry farm consisting of two houses, each of which is above the threshold, where one is owned by the farmer and one by his wife

There are two houses within 500m of each other whose combined numbers are 150,000 broilers. The farmer owns one house of 80,000 birds and his wife owns a second house of 70,000 birds. The farmer operates both houses. Rainwater is separated from dirty water and drains to a common pond. Dirty water from each house drains into a shared effluent tank, and is removed on a regular basis.

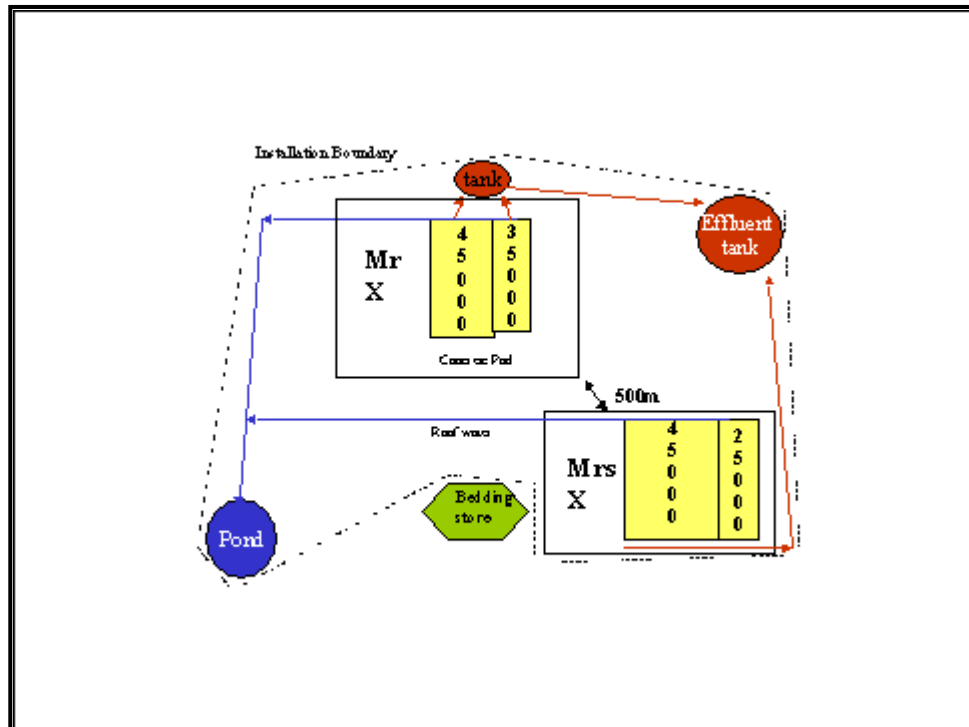

Comment: The activities share the same Operator, are regarded as being on the same site and will be regulated together under ONE permit. The facilities for the DAAs are the shared effluent tank and the surface water system draining to the pond.

However, if it were accepted that Mrs X's activities were under the control of a different Operator, **two** permits would be required, even though the presence of shared DAAs would mean that the units were treated as one STU and there would be one installation. The names of both Operators would be on the individual permits and they would share responsibility for the installation as a whole.

2.3 A duck farm consisting of four animal houses on the same site sharing some services

An Operator has four animal houses, each housing 15,000 ducks, constructed adjacent to each other. The animal houses stand on a concrete pad with a surface water drainage system that discharges, via swales, to a nearby pond. There is a below ground slurry collection tank whose contents are subsequently pumped through a moveable system permanently connected to the effluent system by pipework onto the 10 ha field surrounding the building. Roof water discharges into the swales, which are on grassland adjacent to the concrete pad.

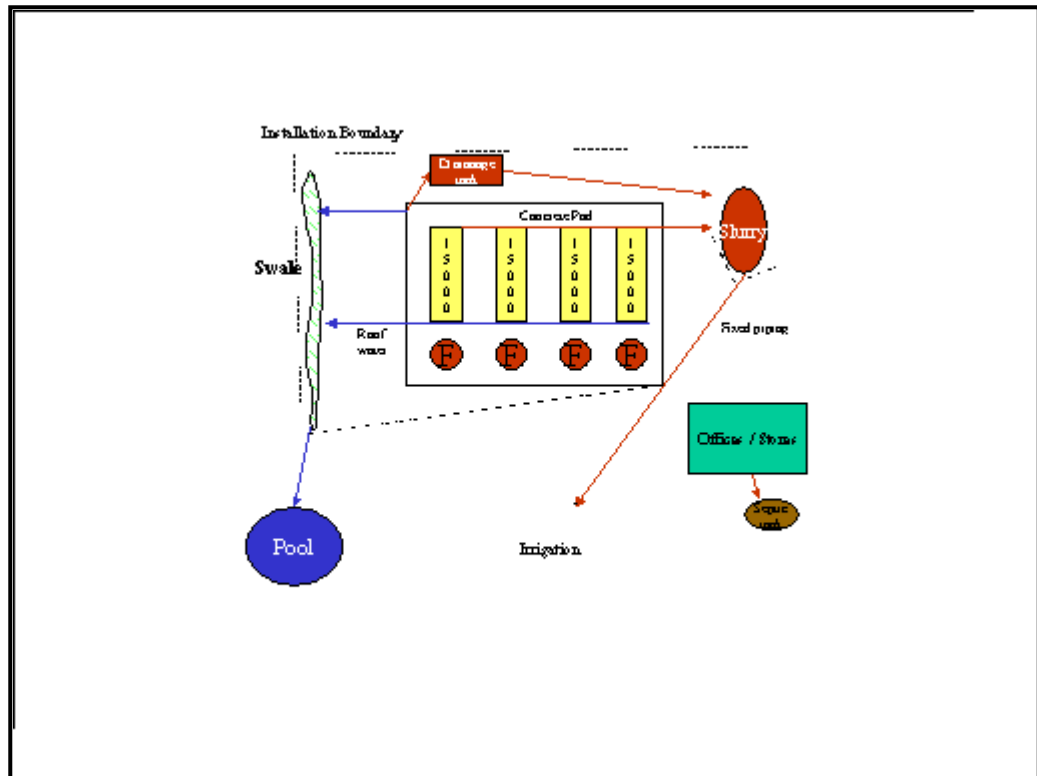

Comment: The installation is the 4 animal houses (aggregated together) with the surrounding hard standing. The DAAs are the below ground tank, the effluent collection system and the surface water treatment system consisting of a swale. The pipework outside the boundary of the installation that connects to the fields is not included as part of the installation. The pond would only be included as a DAA if it were used as a secondary treatment.

2.4 A mixed livestock farm consisting of 40,000+ poultry places and 1500 finishing pigs

Comment: The Operator would only need ONE permit for the poultry operation, as it is the only listed activity; the number of pig places does not meet the relevant threshold. Where an Operator keeps both finishers and sows over the threshold, these activities may be regulated under the same permit even though they are different listed activities. This is because where there are two or more stationary technical units on the same site, those units will be regarded as a single stationary technical unit if:

- (a) they carry out successive steps in one integrated industrial activity;
- (b) one of the listed activities is a directly associated activity of the other; or
- (c) both units are served by the same directly associated activity.

2.5 A pig farm consisting of three groups of animal houses on two sites sharing some services

Sited on various parts of a 2000 ha farm, under the same Operator, are three groups of animal houses associated with pig rearing. One group houses 850 sows and their offspring up to around 30 kg in weight; the second houses 5000 finisher pigs over 30 kg, and the third is where feed milling and raw materials/chemical storage are carried out. The mill supplies feed to all pig houses and is below the threshold required to qualify as a food processing listed activity.

Most of the sow houses are adjacent to each other, but there is a house with places for 80 gilts located across a road. There are facilities for the relevant straw and/or feed storage and/or mixing at each group of animal houses.

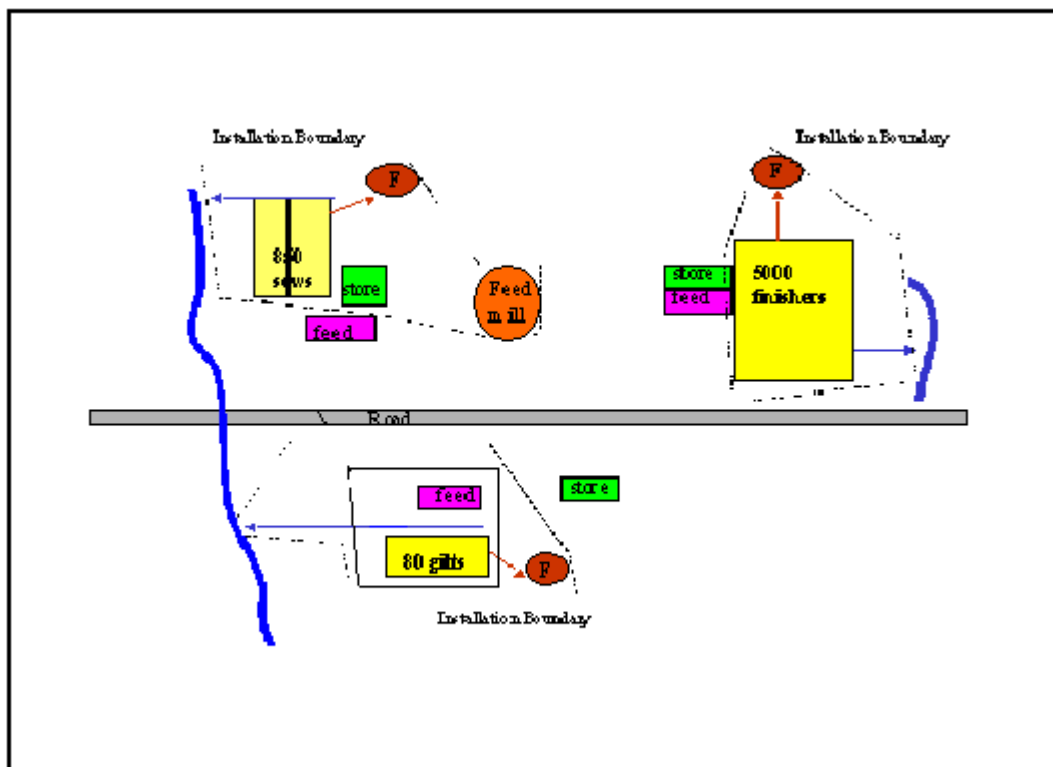

Manure and/or slurry from all houses is stored at the point of production. Surface water from roofs and clean yard drainage is discharged to the river via a soakaway, at each group of houses. Contaminated yard drainage at each group of houses is directed to individual holding tanks and then spread to land.

Comment: There are two listed activities - one for the sows and one for the finisher pigs. The feed mill is a common DAA which serves both activities and brings them within the same installation under one permit. The other DAAs (which are not shared) are the effluent collection and storage system, and surface water treatment system.

The 80 place animal house for gilts, despite being physically separate from the 5,000 place finisher house, will be aggregated with it because gilts are counted towards finishers, they are integral parts of the same operation with the same Operator and a common DAA: the feed mill. Therefore, as a result of this degree of integration, the two sow houses will be regarded as being on the same site under one permit.

2.6 A pig farm where pigs are sent outdoors for finishing

A pig farm has 2500 pig places for finishers of over 30 kg in four animal houses. They have the same Operator. The pigs are then sent outdoors to fields for finishing at 70kg, so that the houses can be used for the next cycle of weaners. There can be as many as 3000 pigs outdoors.

Comment: As there is one Operator carrying out the same activity in different houses on the same site, the capacities of the houses would be aggregated together, bringing them over the threshold. One permit is required for the 2500 finishers, between 30kg and 70kg, which are over the threshold.

2.7 A pig farm consisting of two separate animal houses, one containing finishers and the other containing weaners

Pig house A1 consists of 3000 finishers and is located across a road from pig house A2, which has places for 1000 weaners. The same Operator manages both houses. House A1 receives weaners from House A2 for finishing.

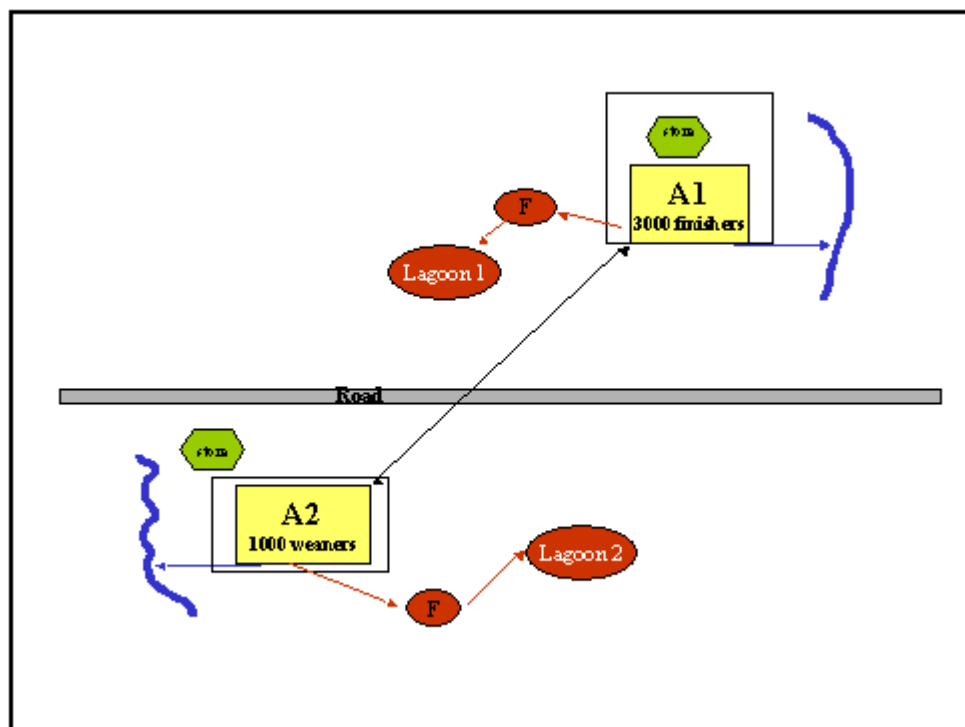

Comment: House A1 is a listed activity, being over 2000 finishers, over 30kg and will require a permit. As House A2 serves House A1, by providing weaners for finishing, it is a DAA and, as such, **will** be regulated under the same permit.

2.8 Where the applicant is a holding company and the operations are carried out by a subsidiary company

Comment: An applicant company (the “holding company”) may seek to argue that it can demonstrate control over operations because it owns the majority of the shares in another company (the “subsidiary company”) which in fact operates the installation. The holding company may assert that this arrangement means that in effect it has control over the operations carried out at the installation. The Environment Agency considers that such arrangements might undermine the express intention of the Regulations that an Operator should be in actual control of operations at an installation. In addition, the Environment Agency would have no way of knowing whether any such shareholdings remained in place. In this scenario, therefore, the subsidiary company rather than the holding company would normally be accepted as the Operator of the installation.

2.9 Where activities within an installation will be carried out by contractors on behalf of an applicant company

Comment: An applicant company may seek to argue that it is the Operator of an installation because, although it has entered into a contract with a third party, it retains control over all the operations. Whilst each case should be considered on its merits, the Environment Agency considers that in many situations such arrangements could undermine the express intention of the Regulations that the permit holder should be in actual control of the operations at an installation. Therefore, in most cases where a company has contracted out the operation of an installation to a third party, the third party will be the Operator. An exception might be where the third party provides the majority of the staff and the equipment for the installation, but the company retains the senior staff providing primary management and operational responsibility.

3. Visual scenarios

Key:

STU - a listed activity i.e. places for over 40,000 birds, 750 sows or 2000 30kg finisher pigs
Non STU - a non-listed activity below the thresholds above e.g. places for 15,000 birds, 500 sows
DAA - directly associated activity

