

ARMY EQUIPMENT
SUPPORT PUBLICATION
Associated publications

- 13 The following publications are associated with this AESP octad.

<u>Reference</u>	<u>Title</u>
JSP 336	Defence Supply Chain Manual

ABBREVIATIONS

- 14 The following abbreviations are used in this AESP octad.

<u>Abbreviation</u>	<u>Nomenclature</u>
a/f	across floats
BSP	British Standard Pipe Thread
BSP F	British Standard Pipe, Fastening Thread
Cd	Cadmium
contd	continued
csk	countersunk
Cu	Copper
c/w	complete with
dia	diameter
galv	galvanised
h	height (high)
hd	head
hex	hexagon (al)
id	inside diameter
in.	inch
lg	length (long)
LH	Left Hand
max	maximum
mm	millimetre
No.	Number
o/a	over-all
od	outside diameter
RH	Right Hand
thd	thread (ed)
thk	thickness
w	width
Zn	Zinc

WARNINGS AND CAUTIONS

HAZARDOUS SUBSTANCES

15 Before using any hazardous substances or material, the user must be conversant with the safety precautions and first aid instructions:

- 15.1 on the label of the container it was supplied in;
- 15.2 on the material Safety Data Sheet;
- 15.3 in local Safety Orders and Regulations.

WARNINGS

FUEL POLICY. THE COOKSET SHOULD ONLY BE USED WITH LIQUEFIED PETROLEUM GAS (LPG) AS A FUEL. GASOLINE HAS BEEN BANNED. ALSO THE USE OF FILTER GENERATORS (FG) NSN 7360-99-132-3584 HAS BEEN PROHIBITED.

CAUTIONS

There are no CAUTIONS applicable to this equipment at this level.

ARMY EQUIPMENT
SUPPORT PUBLICATION

CHAPTER 1

GENERAL INFORMATION

CONTENTS

	Page
Frontispiece	1/2

This Chapter is Not Taken Up

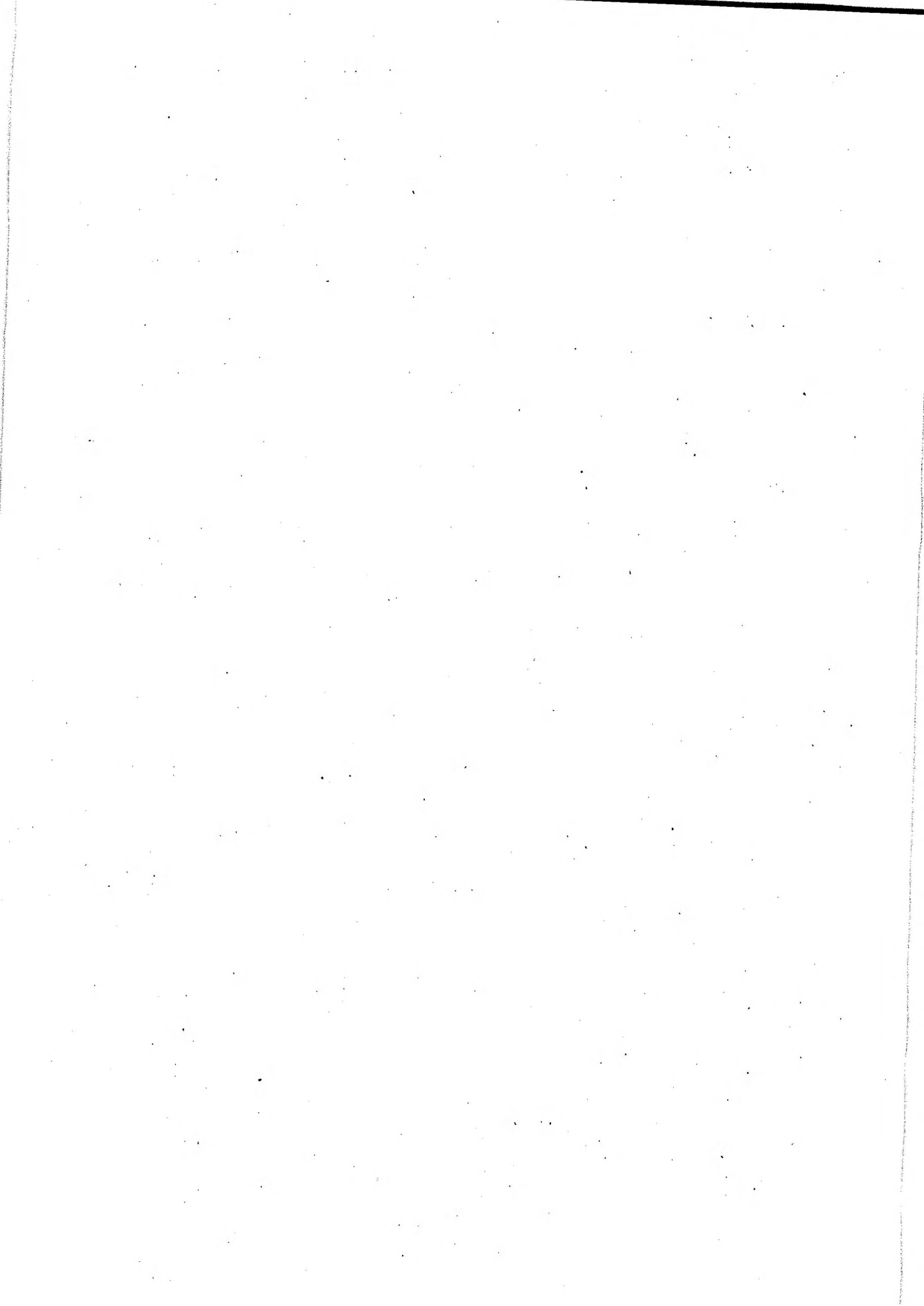

CHAPTER 2-0

COMPLETE EQUIPMENT SCHEDULES (SERVICE)
SIMPLE EQUIPMENT

COOKING OUTFIT FIELD NO. 5
J217360-99-132-2518

CONTENTS

Chapter

2-1 Cooking outfit field No. 5

Page Intentionally Left Blank - No Illustration

CES

Fig. No Item No	DMC NSCM	Army NSN Part Number	Item Description and Annotations	No Off D of Q	Quantity of Issue
NI 0	J2	7360-99-132-2518	COOKING OUTFIT FIELD No. 5 COMPLETE TO CES	1 EA	
NI 1		NIV	. MAIN ITEMS (REFER TO CHAP 2-1)	1 EA	
NI 2		NIV	. TOOLS AND ACCESSORIES (REFER TO CHAP 2-2)	1 EA	
NI 3		NIV	. SPARES (REFER TO CHAP 2-3)		
NI 4		NIV	. LITERATURE (REFER TO CHAP 2-4)		

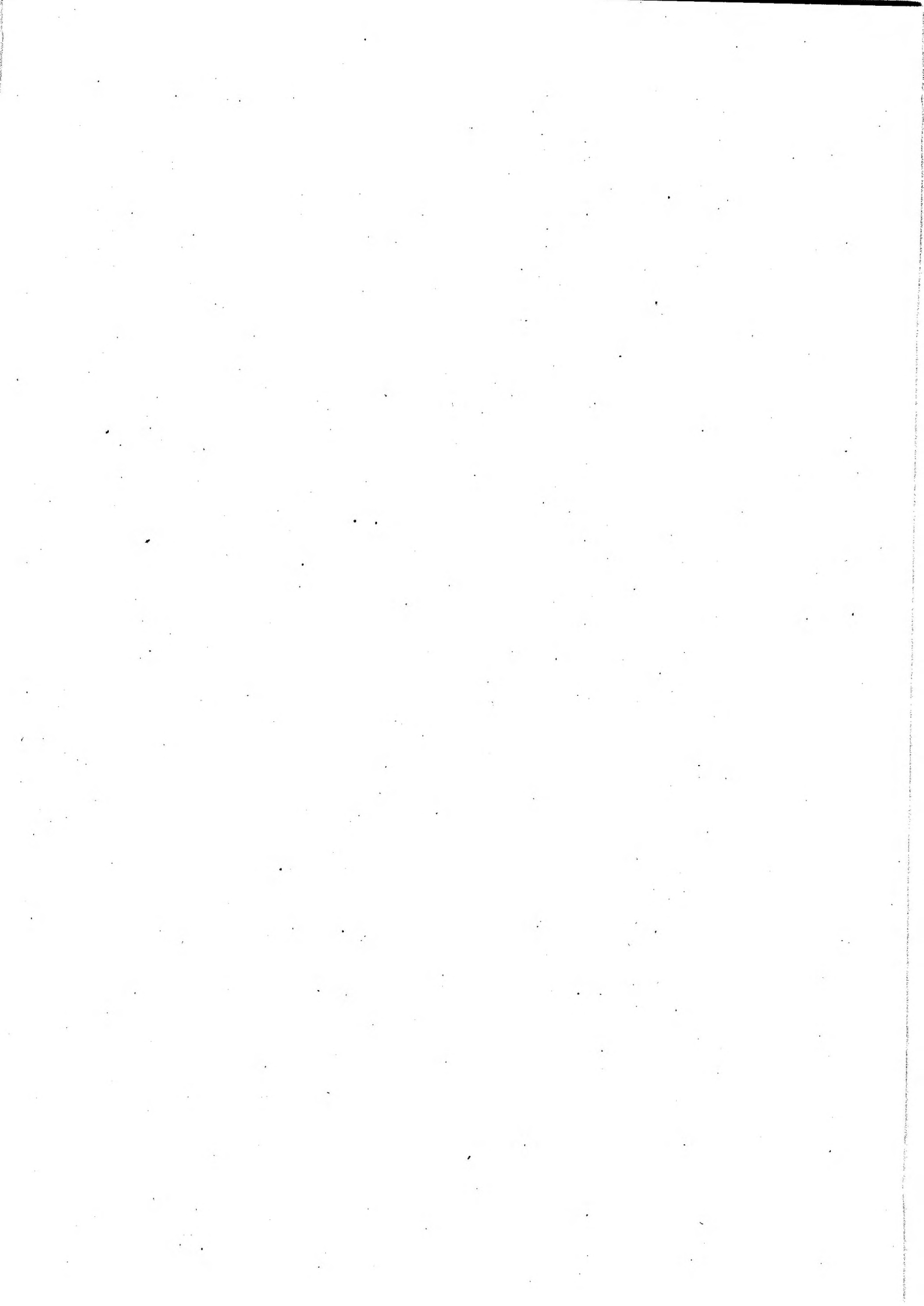

CHAPTER 2-1

COMPLETE EQUIPMENT SCHEDULES (SERVICE)
SIMPLE EQUIPMENT

MAIN ITEMS

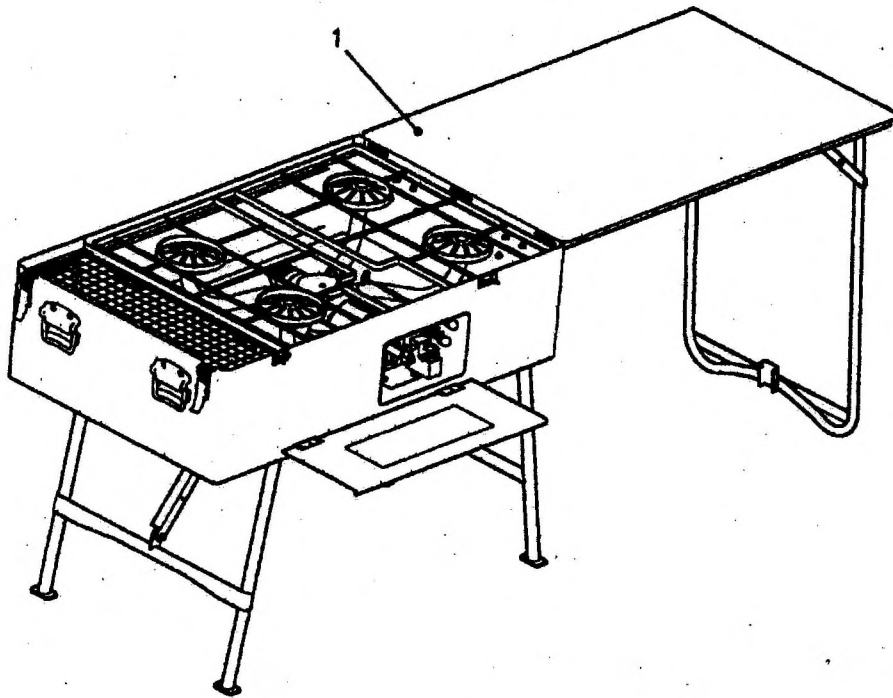

Fig 1 Cooking outfit field No. 5

CES

Fig. No Item No	DMC NSCM	Army NSN Part Number	Item Description and Annotations	No Off D of Q	Quantity of Issue
1			MAIN ITEMS	REF	
NI 0	J2	7360-99-132-2518	COOKING OUTFIT FIELD No. 5, COMPLETE TO CES	1 EA	
1	J2	7360-99-132-4561	COOKER NO. 5 FIELD, COOKING OUTFIT COMPLETE, BURNER UNIT WITH FOLDING TOP (FOLDS TO FORM CARRYING CASE)	1 EA	

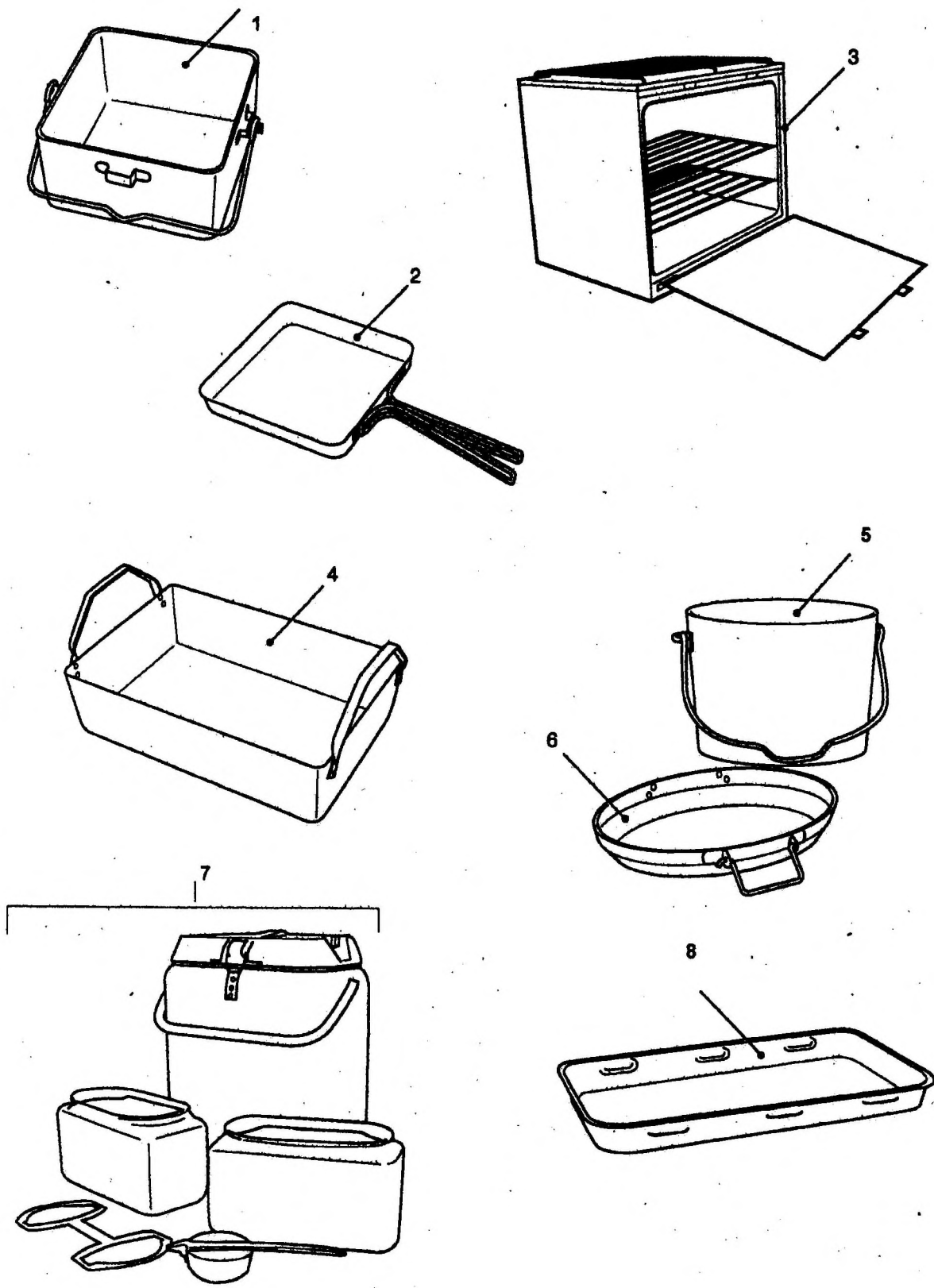

Fig 2 Containers and cooking pots

CES

Fig. No Item No	Army DMC NSCM	NSN Part Number	Item Description and Annotations	No Off D of Q	Quantity of Issue
2			CONTAINERS AND COOKING POTS		
0					
1	J2	7330-99-125-1804	POT, COOKING, 8 1/2 PINT (BODY)	2 EA	
2	J2	7330-99-122-2771	COVER, POT, COOKING, STEEL	2 EA	
3	J2	7360-99-139-1505	OVEN, FIELD COOKING OUTFIT, WITH DROP DOWN DOORS, 2 SHELVES, 5 POSITION WITH GRID ON TOP OF OVEN	1 EA	
4	J2	7330-99-129-1531	POT, COOKING, CORROSION RESISTANT STEEL, RECTANGULAR	1 EA	
5	J2	7330-99-127-6974	POT, COOKING ALUMINIUM ALLOY, OVAL, 3 GAL, W/O COVER, WITH TINNED STEEL HANDLE	4 EA	
6	J2	7330-99-127-6975	COVER, POT, COOKING, ALUMINIUM ALLOY, OVAL, 3 GAL	4 EA	
7	J2	7330-99-300-7605	FOOD CONTAINER, INSULATED, 18 LITRE, C/W INSERTS, LADLE AND INSERT REMOVER	3 EA	
8	J2	7330-99-788-9891	PAN, BAKING AND ROASTING	2 EA	

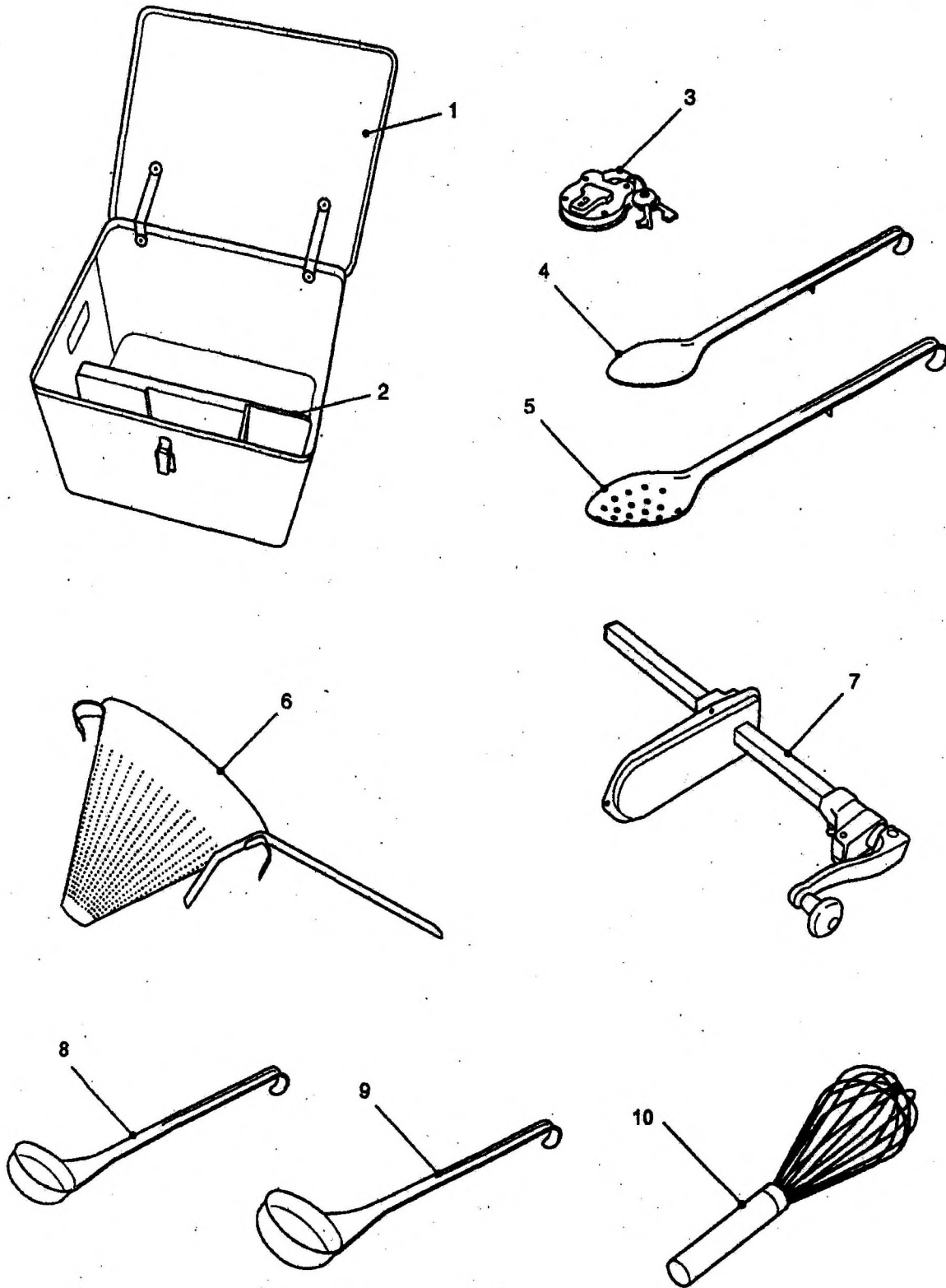

Fig 3 Kitchen utensils

ARMY EQUIPMENT
SUPPORT PUBLICATION

7360-G-100-741

CES

Fig. No Item No	DMC NSCM	Army NSN Part Number	Item Description and Annotations	No Off D of Q	Quantity of Issue
3			KITCHEN UTENSILS	REF	
1	J2	7360-99-132-3572	. BOX, METAL, KITCHEN FIELD COOKING OUTFIT	1 EA	
2	J2	7360-99-138-5896	. . . INSERT, KITCHEN BOX FIELD COOKING OUTFIT, PLYWOOD, 475 MM X 495 MM X207 MM WITH PROVISION FOR STOWAGE OF KITCHEN UTENSILS	1 EA	
3	G1	5340-99-910-8185	. PADLOCK, 1 1/2 IN.	1 EA	
4	DAS	7340-99-459-9701	. SPOON, SERVICE PLAIN	4 EA	
5	DAS	7340-99-481-9622	. SPOON, SERVICE PERFORATED	1 EA	
6	DAS	7330-99-761-1618	. STRAINER, POT	1 EA	
7	DAS	7330-99-741-3433	. OPENER, CAN TABLE MOUNTED	1 EA	
8	DAS	7330-99-549-9101	. LADLE, KITCHEN, 1/4 PINT	1 EA	
9	DAS	7330-99-134-7866	. LADLE, KITCHEN, 1/2 PINT	2 EA	
10	DAS	7330-99-403-6031	. WHISK, EGG	1 EA	

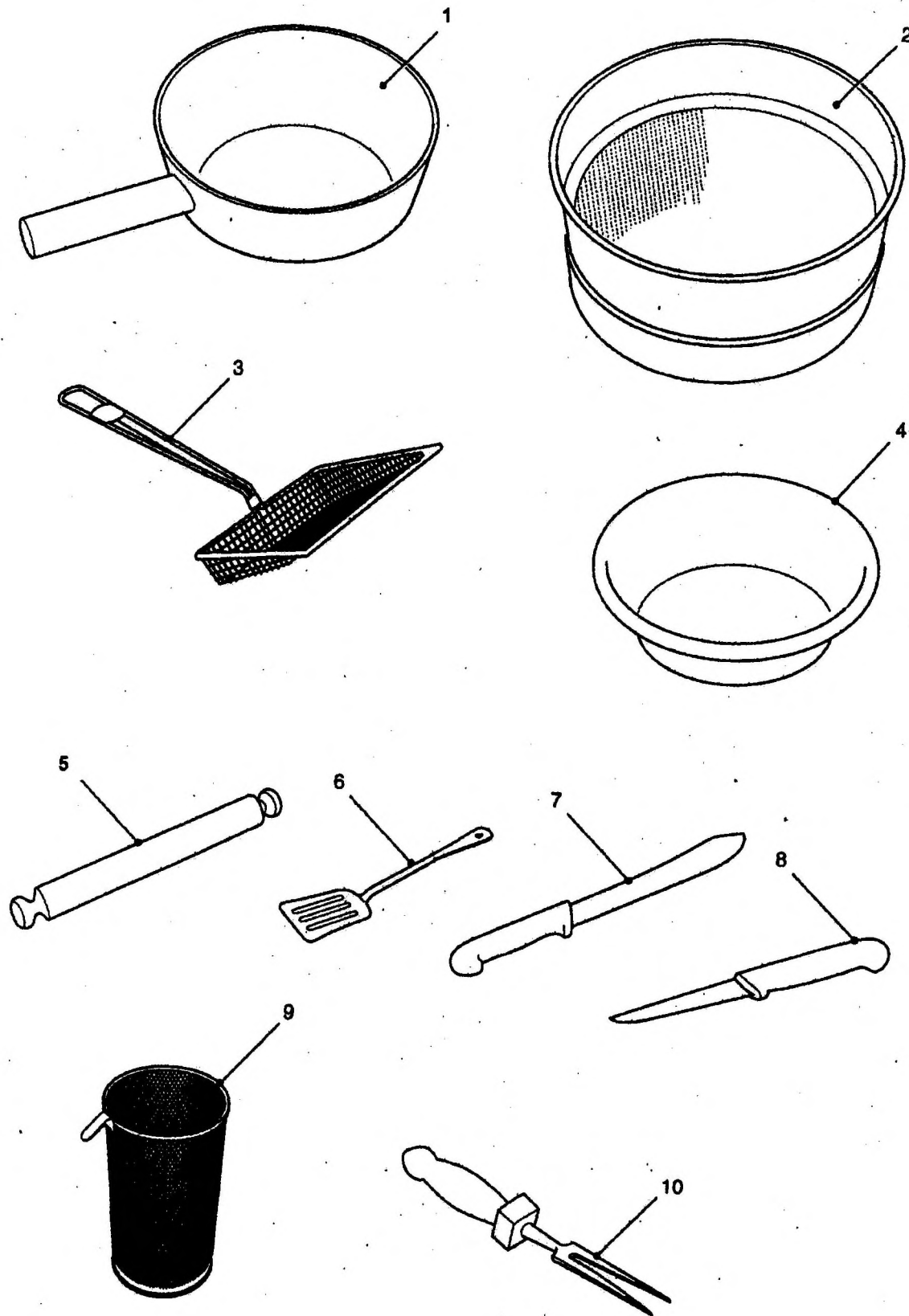

Fig 4 Kitchens utensils

CES

Fig. No Item No	Army		Item Description and Annotations	No Off D of Q	Quantity of Issue
	DMC NSCM	NSN Part Number			
4			KITCHEN UTENSILS - Contd	REF	
0					
1	DAS10	7330-99-129-2161	BOWL, HAND	1 EA	
2	DAS	7330-99-991-1198	SIEVE, FLOUR,	1 EA	
3	DAS	7330-99-724-3340	SKIMMER, FRYING	1 EA	
4	DAS	7240-99-724-3360	BASIN, WASH	1 EA	
5	DAS	7330-99-706-3760	PIN, ROLLING	1 EA	
6	DAS	7330-99-225-8920	SLICE, FOOD	2 EA	
7	DAS	7340-99-596-9775	KNIFE, BUTCHER, RED	1 EA	
8	DAS	7340-99-356-9101	KNIFE, VEG, 4 IN. GREEN	3 EA	
9	J2	7380-99-132-3573	INFUSER, TEA, CRESCENT BODY AND FRAME; CRESCENT WOVEN WIRE, 6 IN. LONG, 3 IN. DIA (APPROX), WITH HANDLE	1 EA	
10	DAS	7340-99-802-2910	FORK, COOK	1 EA	

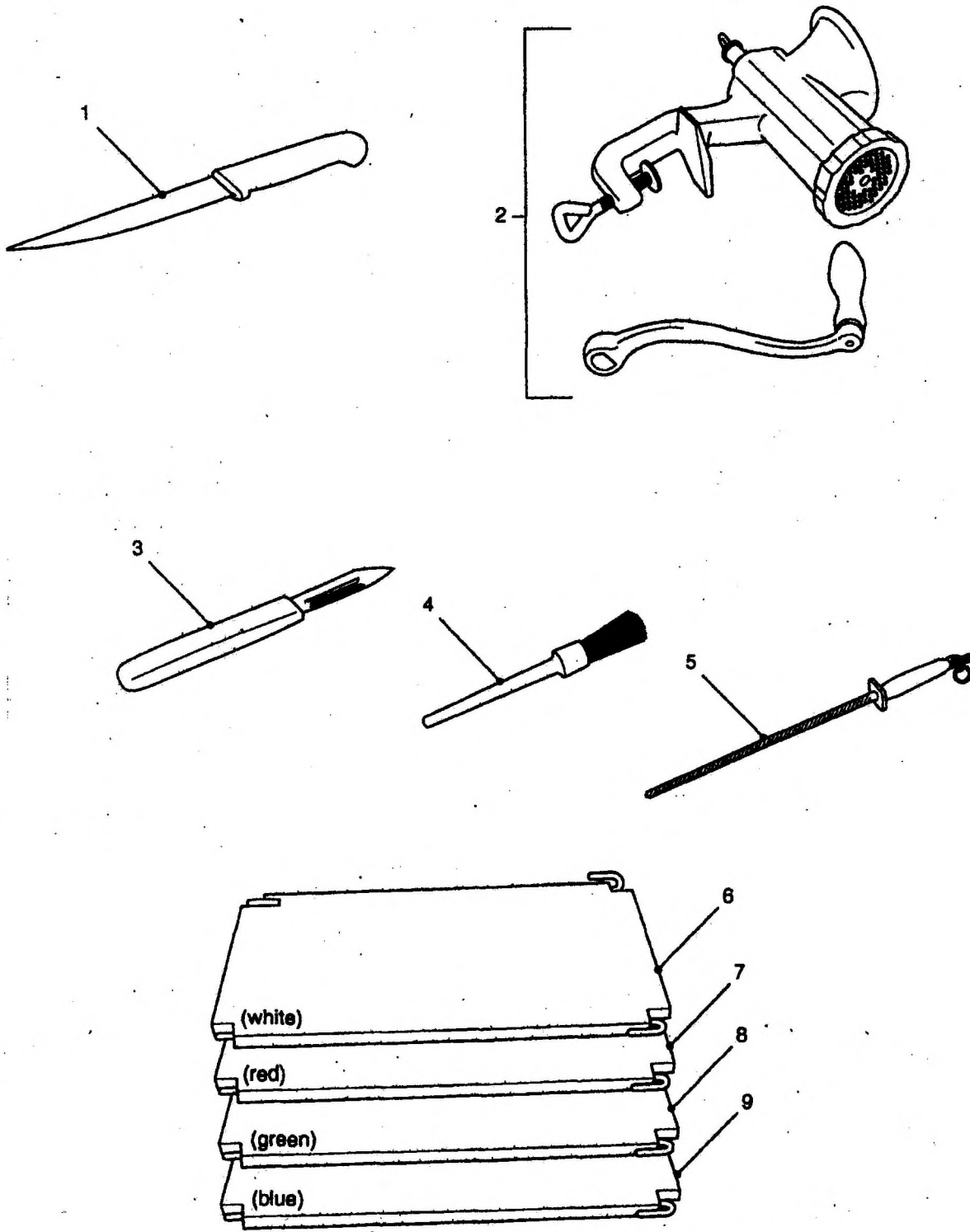

Fig 5 Kitchens utensils

ARMY EQUIPMENT
SUPPORT PUBLICATION

7360-G-100-741

CES

Fig. No Item No	DMC NSCM	Army NSN Part Number	Item Description and Annotations	No Off D of Q	Quantity of Issue
4			KITCHEN UTENSILS - Contd.		
0				1	
1	DAS	7340-99-724-3264	KNIFE, 8 1/2 IN. GREEN	EA	
2	DAS	7330-99-428-7304	MACHINE MINCING, HAND	1	
3	DAS	7330-99-577-1910	PEELER, POTATO, HAND	EA	2
4	DAS	7330-99-279-8672	BRUSH, PASTRY	EA	1
5	DAS	7330-99-913-0632	STEEL, BUTCHERS	EA	1
6	DAS	7330-99-510-0733	BOARD, CHOPPING, WHITE	EA	1
7	DAS	7330-99-238-1765	BOARD, CHOPPING, RED	EA	1
8	DAS	7330-99-253-8486	BOARD, CHOPPING, GREEN	EA	1
9	DAS	7330-99-915-4825	BOARD, CHOPPING, BLUE	EA	1
10	DAS 10	7320-99-754-3029	FOOD TEMPERATURE PROBE, DIGITAL	EA	1
11	DAS10	7320-99-000-5890	WIPES, FOOD TEMPERATURE PROBE	TU	1

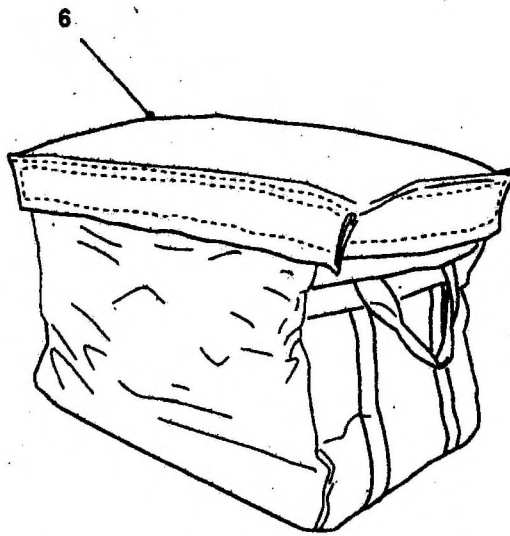
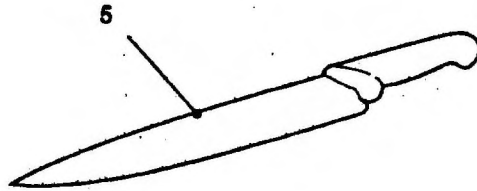
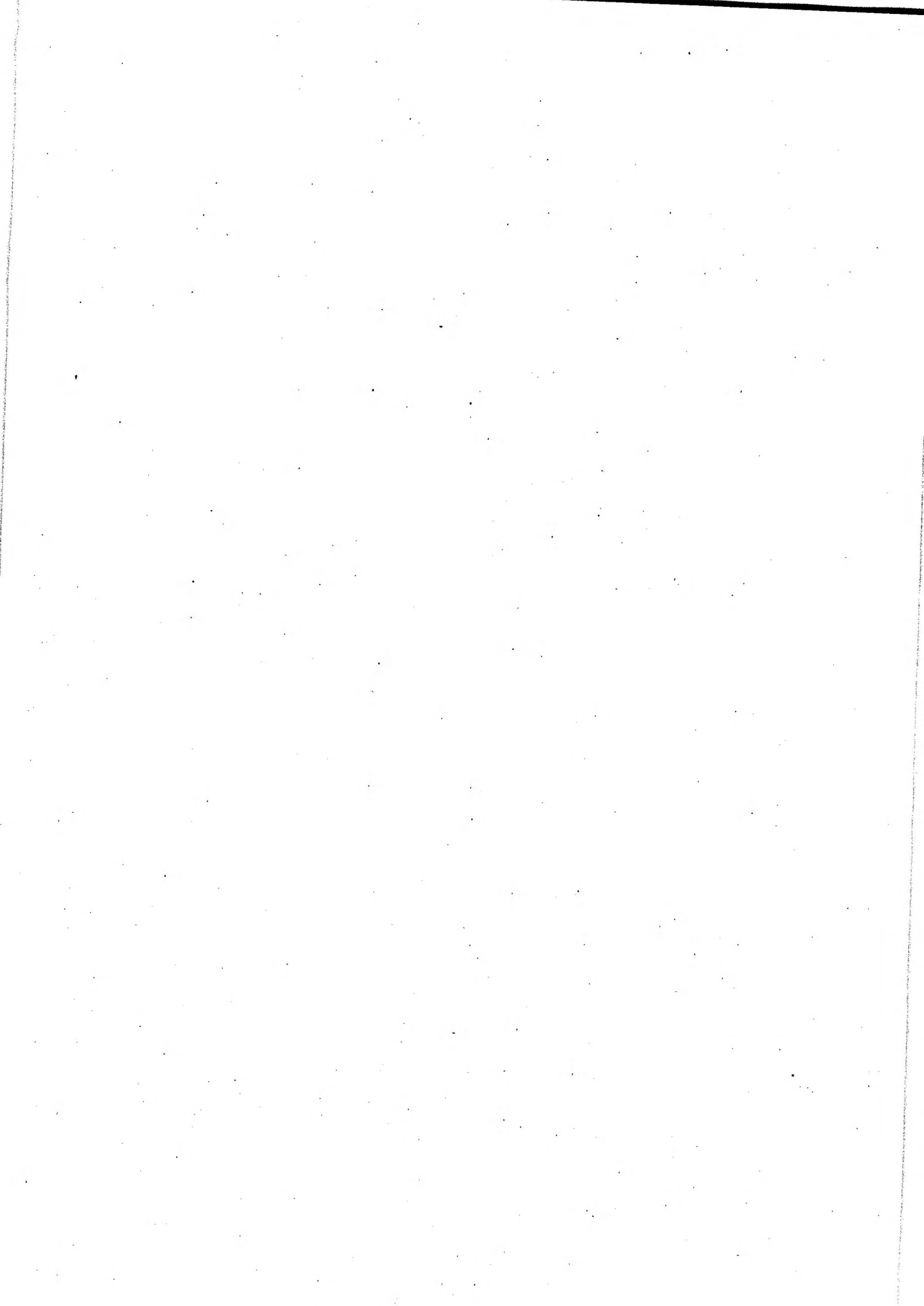

Fig 6 Kitchens utensils

ARMY EQUIPMENT
SUPPORT PUBLICATION

CES

Fig. No Item No	Army		Item Description and Annotations	No Off D of Q	Quantity of Issue
	DMC NSCM	NSN Part Number			
6 0			KITCHEN UTENSILS - Contd.		
NI 1	DAS	7330-99-132-9900	SPOON, PLASTIC, 247 MM LONG	1 EA	
NI 2	DAS	7340-99-212-7467	KNIFE, FILLETING, BLUE	1 EA	
M 3	DAS	7340-99-883-3296	KNIFE, BONING, RED	1 EA	
NI 4	DAS	7340-99-212-7468	KNIFE, HAM, 12 IN. WHITE	1 EA	
5	DAS	7340-99-505-2242	KNIFE, COOKS, 10 IN. WHITE	1 EA	
6	J2	7310-99-602-1547	BAG, THERMAL, 80 LITRE	1 EA	



CHAPTER 2-1-1

COMPLETE EQUIPMENT SCHEDULES (SERVICE)
SIMPLE EQUIPMENT

TOOLS AND ACCESSORIES

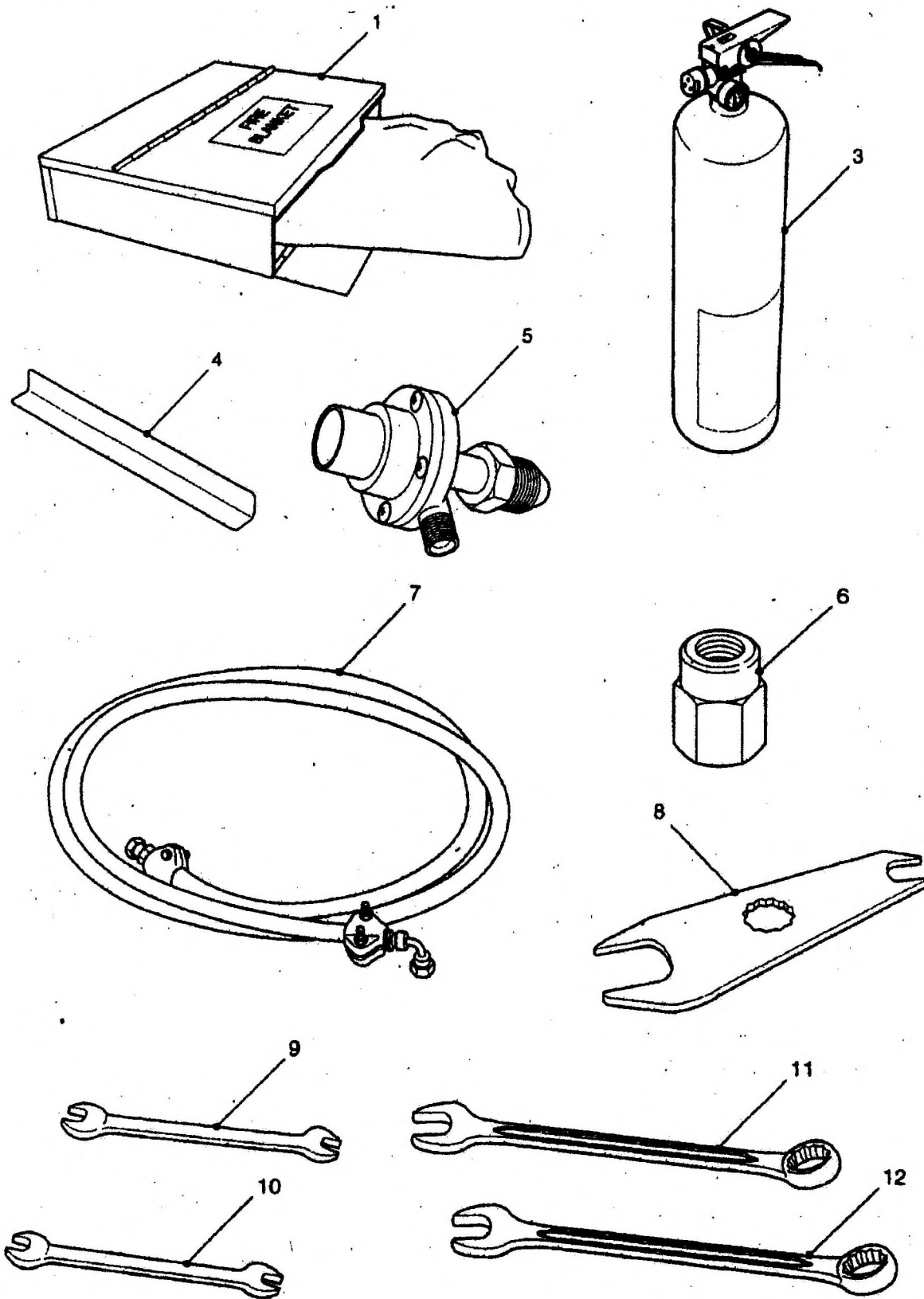
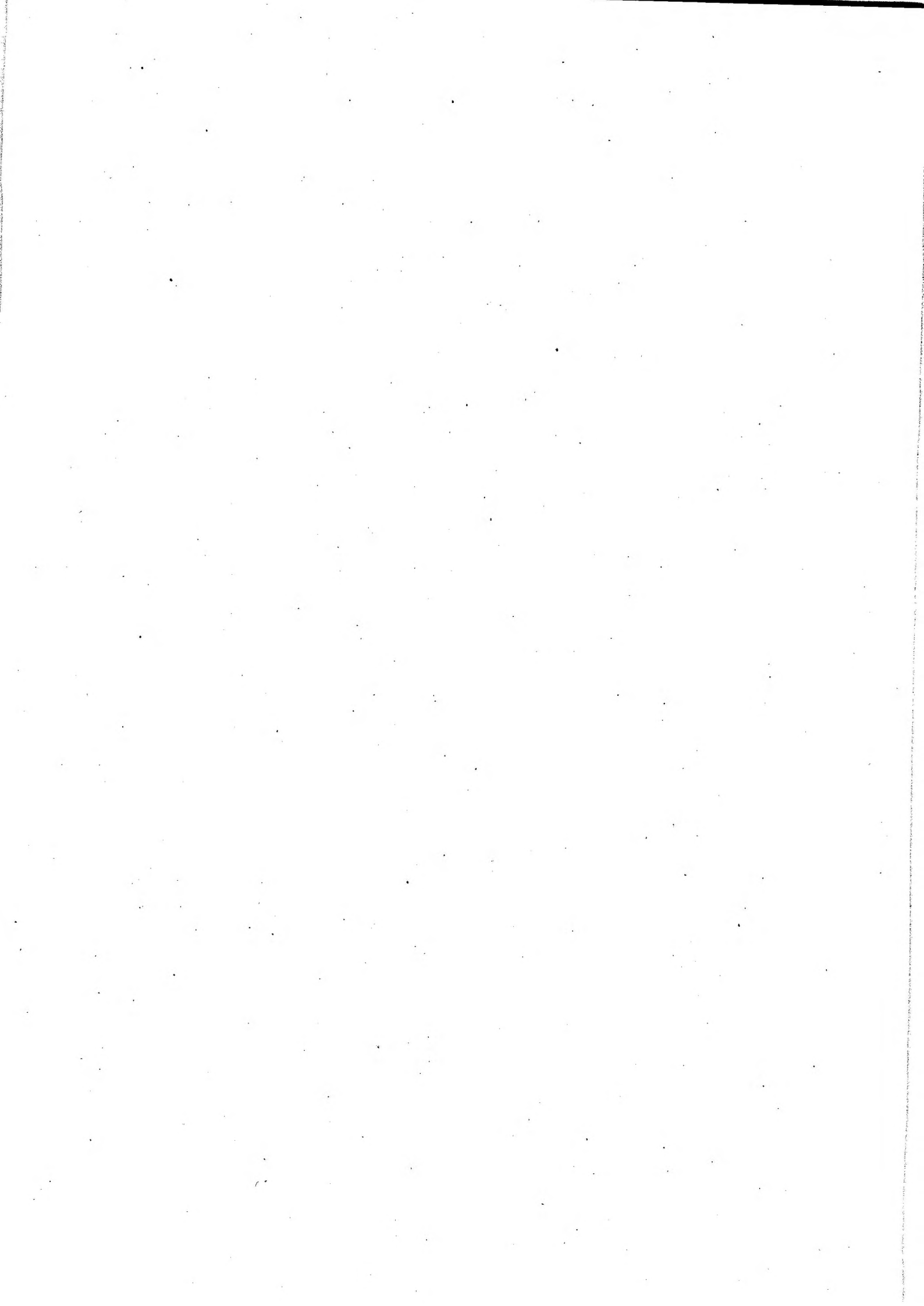

Fig 7 Cooking outfit field No. 5

CES

Fig. No Item No	DMC NSCM	Army NSN Part Number	Item Description and Annotations	No Off D of Q	Quantity of Issue
1					
0			TOOLS AND ACCESSORIES	REF	
1	DAS	4210-99-225-7200	.BLANKET, FIRE, CWV CONTAINER	1 EA	
2			. NOT USED		
3	6MT1	4210-99-998-3537	. EXTINGUISHER, FIRE, POWDER	1 EA	
4	J2	7310-99-406-2286	.CLEANER, BURNER SLOTS, FIELD COOKER, L SHAPE	3 EA	
5	J2	4820-99-785-3583	.REGULATOR ASSY, FLUID PRESSURE, INLET	1 EA	
6	J2	4730-99-508-2538	. ADAPTOR, COMPRESSED GAS CYLINDER (FOR USE IN GERMANY)	1 EA	
7	J2	4720-99-470-7029	.HOSE, FUEL, ARMOURED, 6 M	1 EA	
8	J2	7360-99-132-3583	.SPANNER, COMBINATION, ST, DOUBLE ENDED, 15.65 MM MIN - 15.70 MM MAX A/F SMALL END, 30.65 MM MIN - 30.80 MM MAX A/F LARGE END	1 EA	
9	F1	5120-99-910-6228	.SPANNER, O/J FIXED, DOUBLE ENDED, 1/4 IN. BS (3/16 IN. W), 5/16 IN. BS (1/4 IN. W), 5 IN. TO 5 3/4 IN. LONG	1 EA	
10	F1	5120-99-910-6289	. SPANNER, O/J FIXED DBLE ENDED 10 MM X 11 MM	2 EA	
11	F1	5120-99-138-6844	. SPANNER, COMBINATION 18 MM	1 EA	
12	F1	5120-99-139-3638	. SPANNER, COMBINATION 19 MM	1 EA	



CHAPTER 2-1-2

COMPLETE EQUIPMENT SCHEDULES (SERVICE)
SIMPLE EQUIPMENT

SPARES

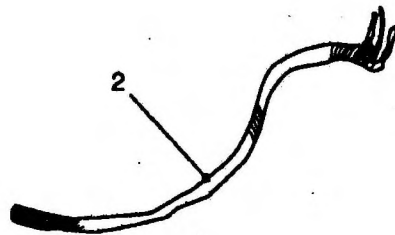
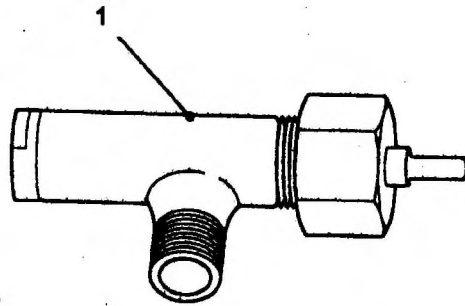
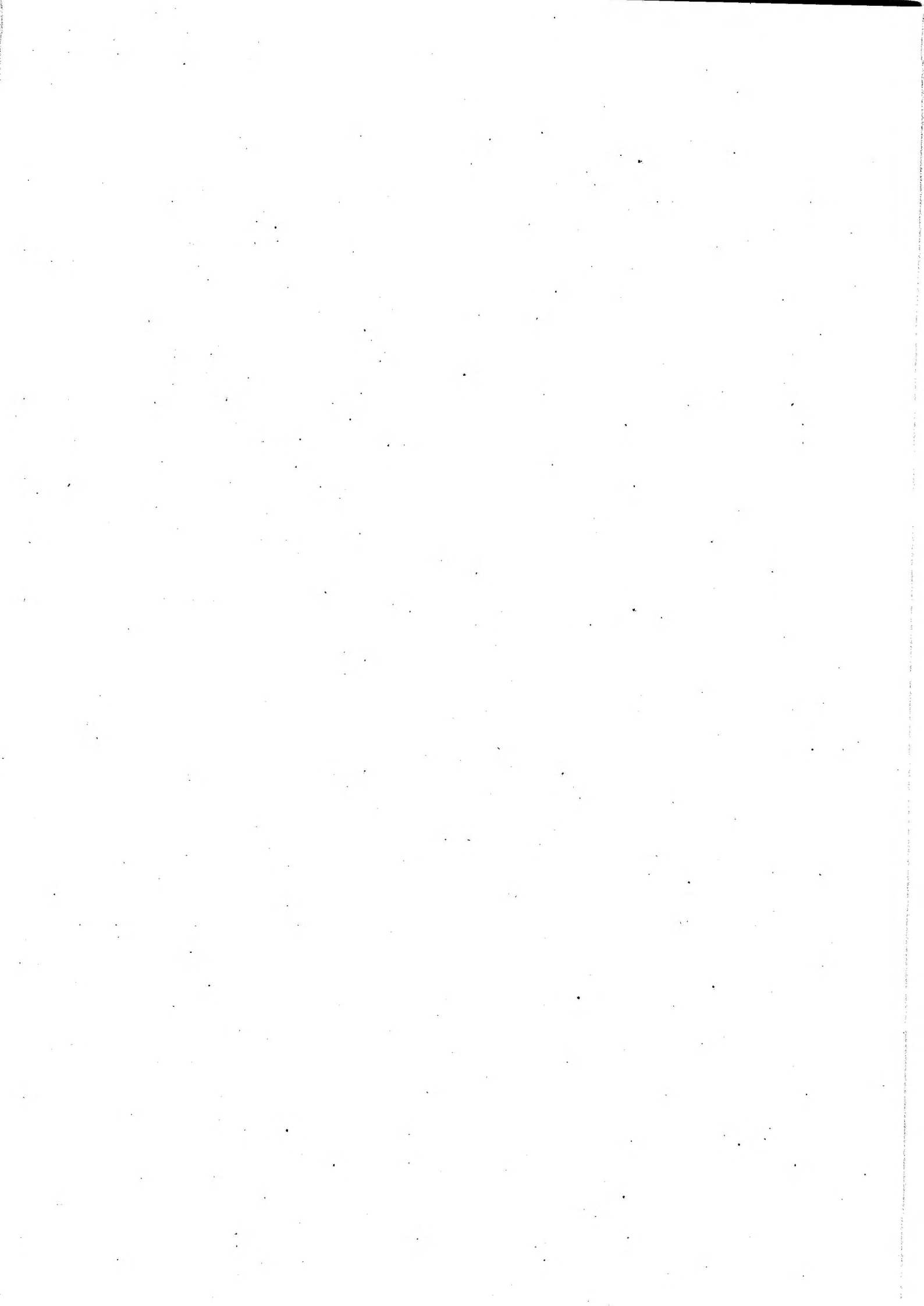

Fig 8 Spares

CES

Fig. No Item No	DMC NSCM	Army NSN Part Number	Item Description and Annotations	No Off D of Q	Quantity of Issue
1 0			SPARES	REF	
1	J2	7360-99-132-3578	. VALVE ASSY, CONTROL, FIELD COOKING OUTFIT, COMPLETE READY FOR CONNECTING TO TRANSFER BLOCK	1 EA	
2	J2	5330-99-380-6505	. PACK MATERIAL, RD CROSS SECTION SHAPE, TWISTED STRAND TYPE, CUT LONG (6 IN.) (PACKET OF 6)	2 PK	



CHAPTER 2-2

COMPLETE EQUIPMENT SCHEDULES (SERVICE)
SIMPLE EQUIPMENT

LITERATURE

Page Intentionally Left Blank - No Illustration

ARMY EQUIPMENT
SUPPORT PUBLICATION

7360-G-100-741

CES

Fig. No Item No	DMC NSCM	Army NSN Part Number	Item Description and Annotations	No Off D of Q	Quantity of Issue
0			LITERATURE	REF	
1	AESP	7360-G-100-101	PURPOSE AND PLANNING INFORMATION	1 EA	
NI 2	AESP	7360-G-100-201	OPERATING INSTRUCTIONS	1 EA	
NI 3	AESP	7360-G-100-601	MAINTENANCE SCHEDULES	1 EA	
NI 4	AESP	7360-G-100-711	ILLUSTRATED PARTS CATALOGUES	1 EA	
NI 5	AESP	7360-G-100-741	COMPLETE EQUIPMENT SCHEDULE (SERVICE) SIMPLE EQUIPMENT	1 EA	
NI 6	AESP	7360-G-100-811	MODIFICATION INSTRUCTIONS AND INDEX	1 EA	
NI 7	AESP	7360-G-100-821	GENERAL INSTRUCTIONS AND INDEX	1 EA	

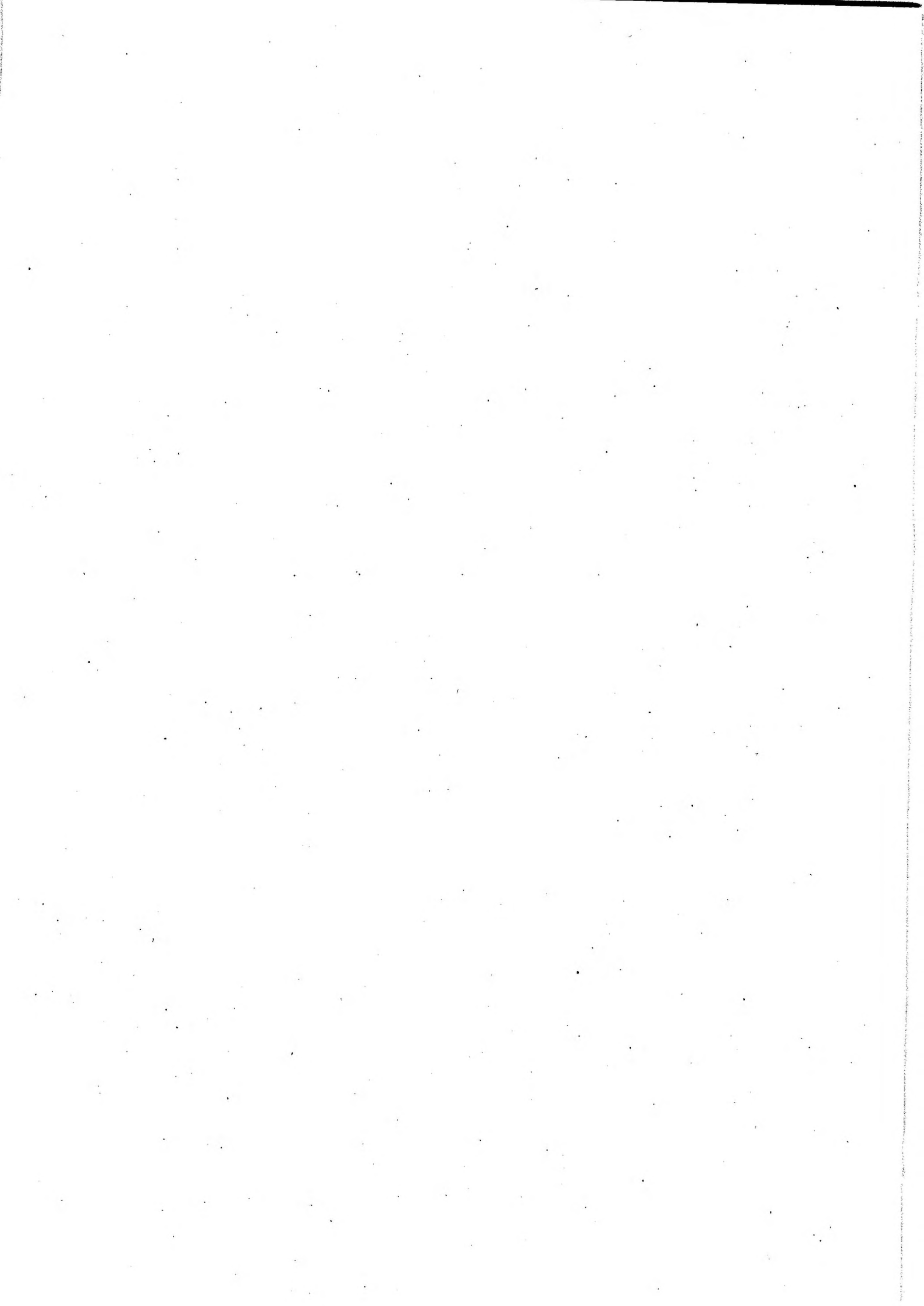

CHAPTER 3

INDEXES

CONTENTS

Para

1 Introduction

Chapter

- 3-1 Index of NATO Stock Numbers to Chapter, Figure and Item Numbers
- 3-2 Index of Manufacturers' Part/Drawing Numbers to Chapter, Figure and Item Numbers
- 3-3 Not issued
- 3-4 Not issued

INTRODUCTION

- 1 This chapter identifies the number of indexes provided in support to the CES List.

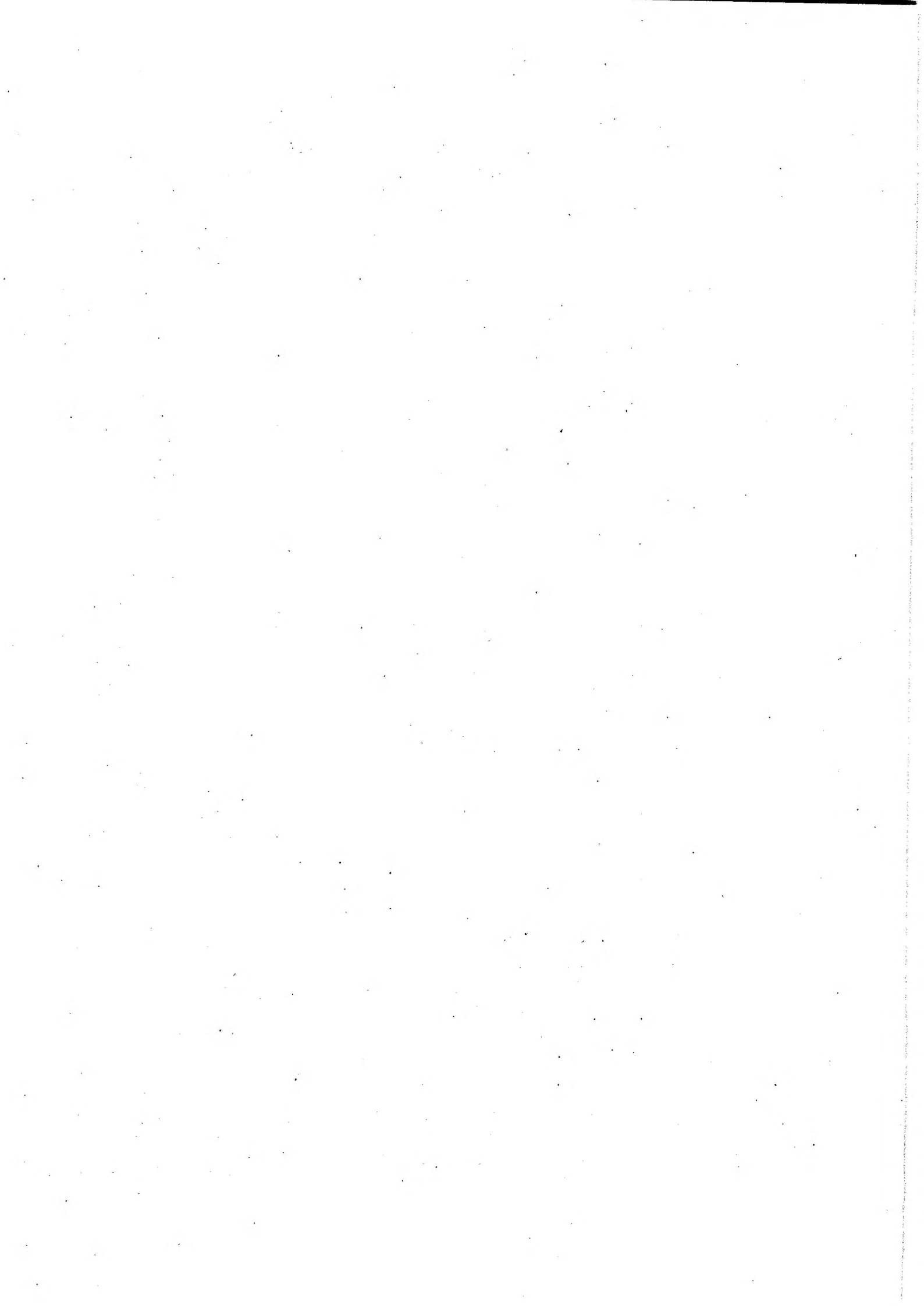

CHAPTER 3-1

INDEX OF NATO STOCK NUMBERS
TO
CHAPTER, FIGURE AND ITEM NUMBERS

CONTENTS

	Page
Index pages	3

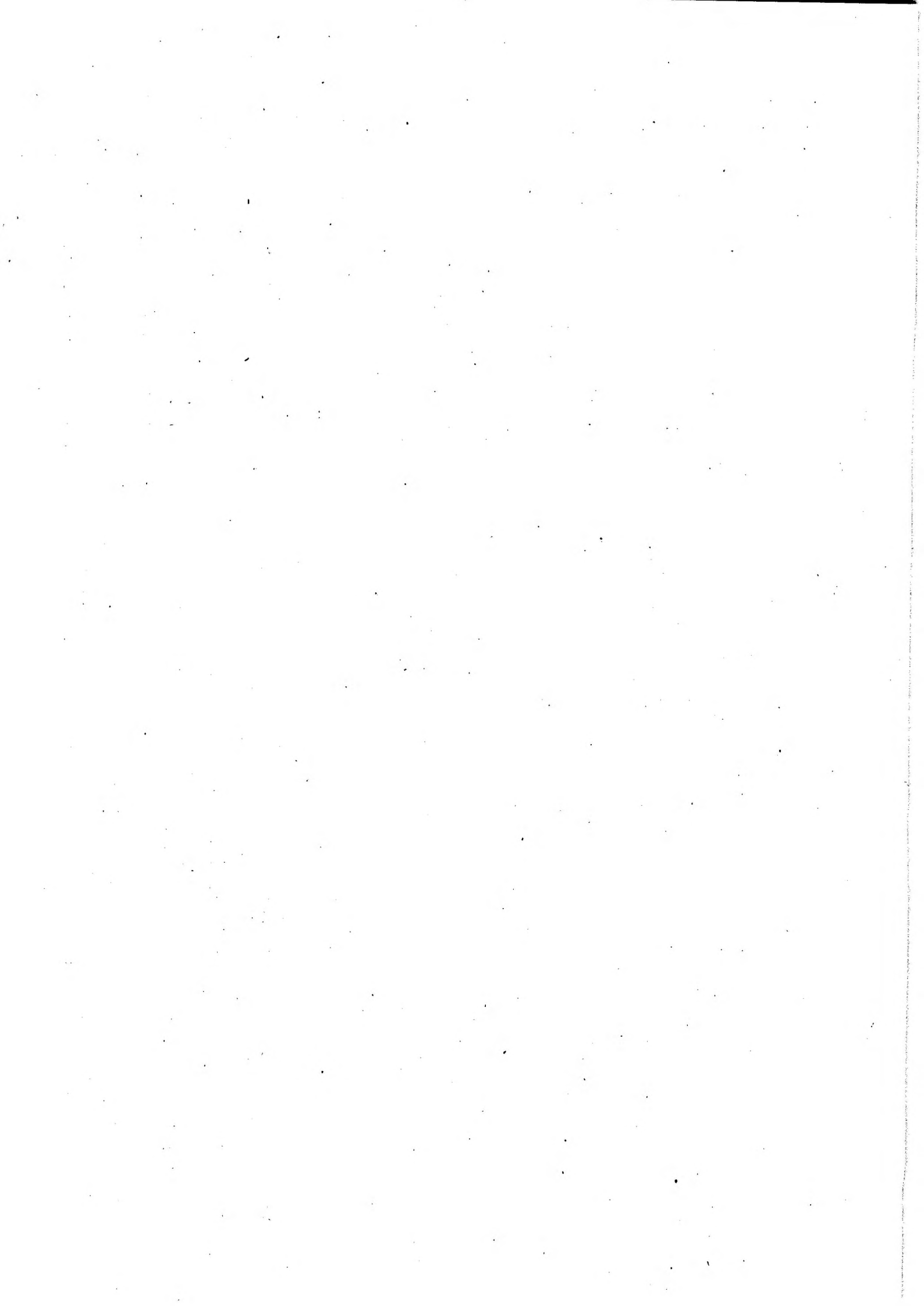

INDEX OF NATO STOCK NUMBERS
TO
CHAPTER, FIGURE AND ITEM NUMBERS

NATO Stock Number	Chapter 2-sub-chap	Fig & Item
7320-99-000-5890	1-1	5-NI 11
7330-99-122-2771	1-1	2-2
7330-99-125-1804	1-1	2-1
7330-99-127-6974	1-1	2-5
7330-99-127-6975	1-1	2-6
7330-99-129-1531	1-1	2-4
7330-99-129-2161	1-1	4-1
7360-99-132-2518	0	1-NI 1
7360-99-132-3572	1-1	3-1
7360-99-132-3573	1-1	4-9
7360-99-132-3578	1-3	1-1
7360-99-132-3583	1-2	1-8
7360-99-132-4561	1-1	1-1
7330-99-132-9900	1-1	6-NI 1
7330-99-134-7866	1-1	3-9
7360-99-138-5896	1-1	3-2
5120-99-138-6844	1-2	1-11
7360-99-139-1505	1-1	2-3
5120-99-139-3638	1-2	1-12
7340-99-212-7467	1-1	6-NI 2
7340-99-212-7468	1-1	6-NI 4
4210-99-225-7200	1-2	1
7330-99-225-8920	1-1	4-6
7330-99-238-1765	1-1	5-7
7330-99-253-8486	1-1	5-8
7330-99-279-8672	1-1	5-4
7330-99-300-7605	1-1	2-7
7340-99-356-9101	1-1	4-8
5330-99-380-6505	1-3	1-2
7330-99-403-6031	1-1	3-10
7310-99-406-2286	1-2	1-4
7330-99-428-7304	1-1	5-2
7340-99-459-9701	1-1	3-4
4720-99-470-7029	1-2	1-7
7340-99-481-9622	1-1	3-5
7340-99-505-2242	1-1	6-5
4730-99-508-2538	1-2	1-6
7330-99-510-0733	1-1	5-6
7330-99-549-9101	1-1	3-8
7330-99-577-1910	1-1	5-3
7340-99-596-9775	1-1	4-7
7310-99-602-1547	1-1	6-6
7330-99-708-3760	1-1	4-5
7340-99-724-3264	1-1	5-1
7330-99-724-3340	1-1	4-3
7240-99-724-3360	1-1	4-4
7330-99-741-3433	1-1	3-7
7330-99-761-1618	1-1	3-6
4820-99-785-3583	1-2	1-5

NATO Stock Number	Chapter 2-sub-chap	Fig & Item
7330-99-788-9891	1-1	2-8
7340-99-802-2910	1-1	4-10
7320-99-846-6252	1-1	5-NI 10
7340-99-883-3296	1-1	6-NI 3
5120-99-910-6228	1-2	1-9
5120-99-910-6289	1-2	1-10
5340-99-910-8185	1-1	3-3
7330-99-913-0632	1-1	5-5
7330-99-915-4825	1-1	5-9
7330-99-991-1198	1-1	4-2
4210-99-998-3537	1-2	1-3

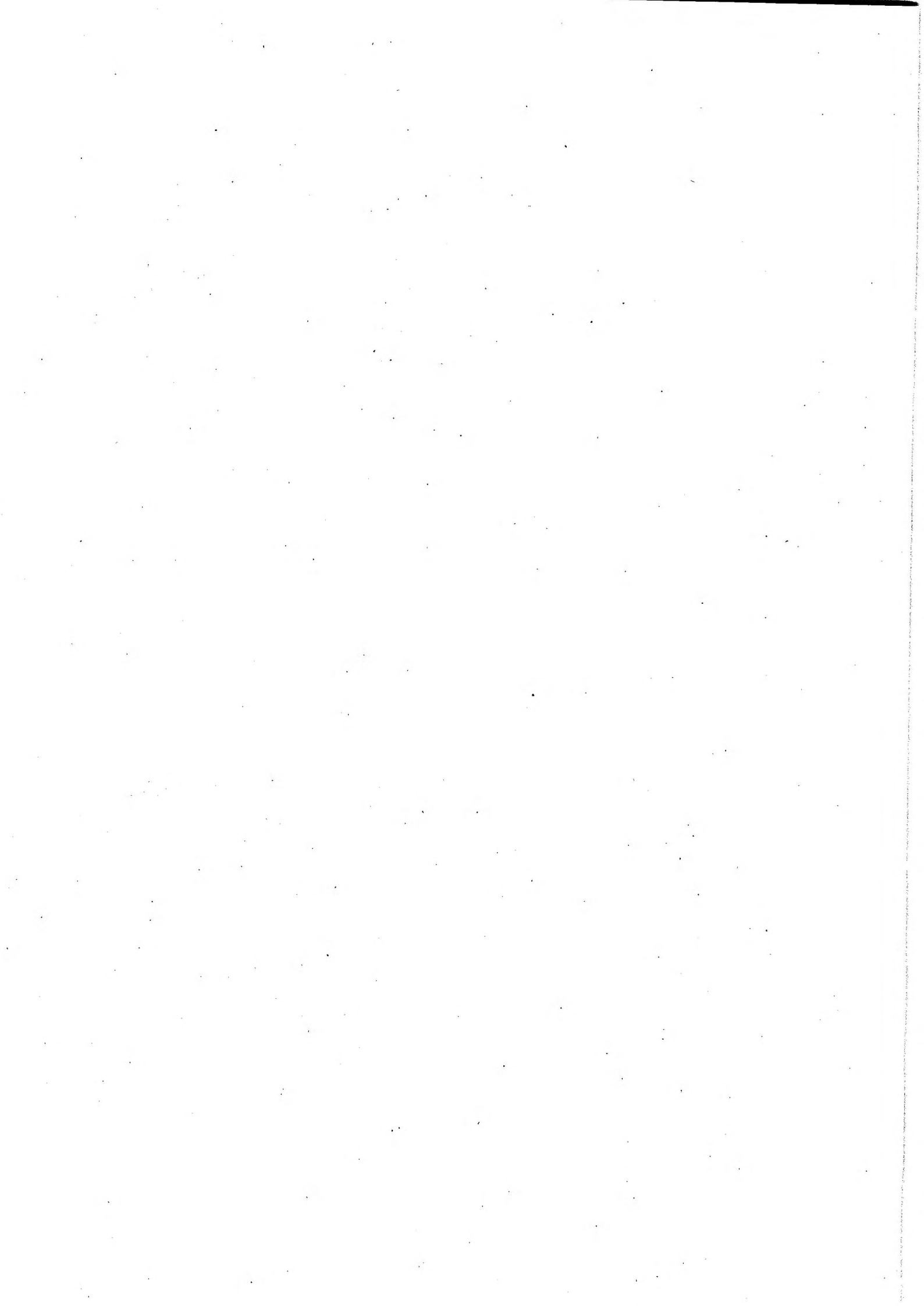

CHAPTER 3-2

INDEX OF MANUFACTURERS' PART/DRAWING NUMBERS
TO
CHAPTER, FIGURE AND ITEM NUMBERS

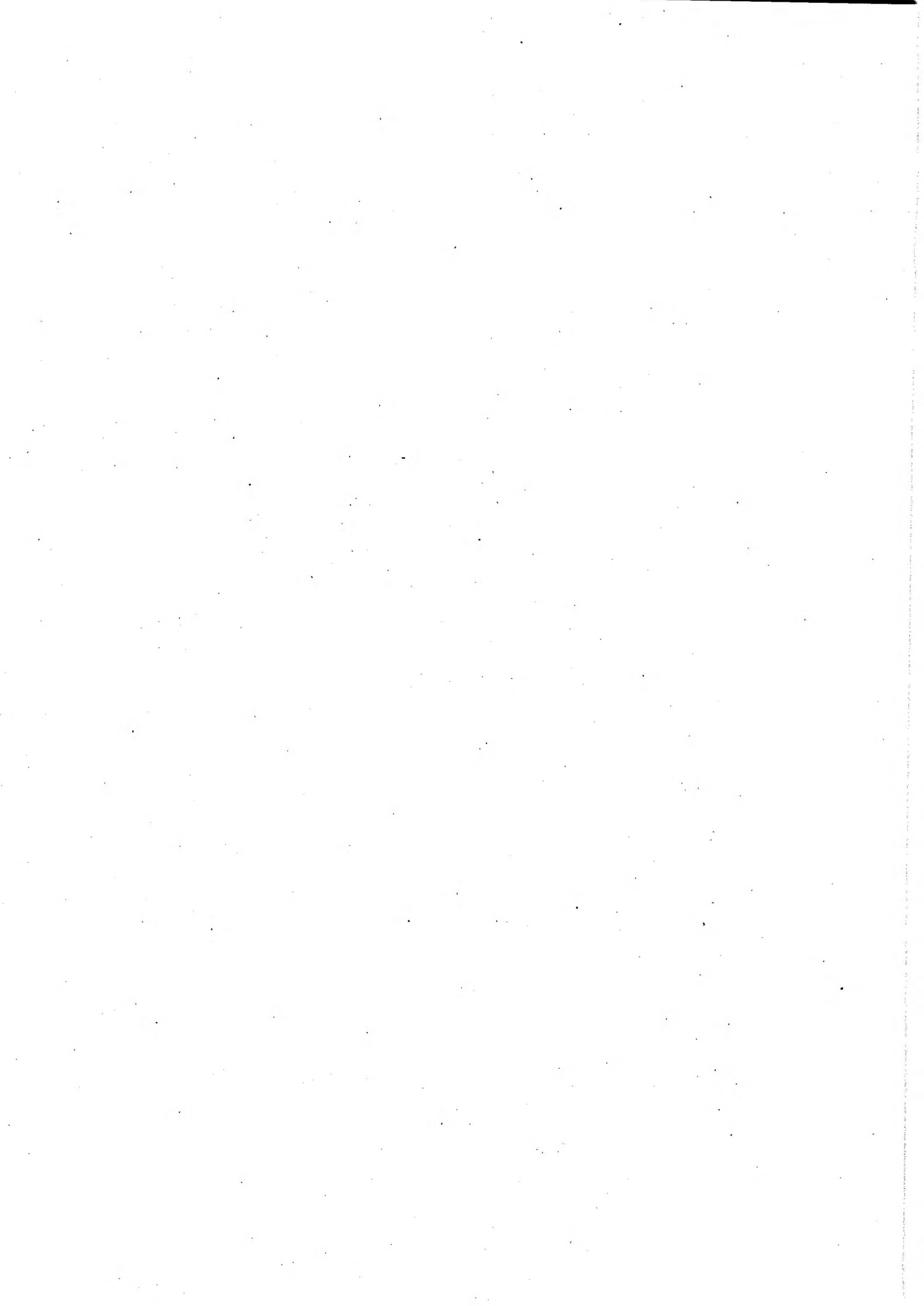

ARMY EQUIPMENT
SUPPORT PUBLICATIONINDEX OF MANUFACTURERS' PART/DRAWING NUMBERS
TO CHAPTER, FIGURE AND ITEM NUMBERS

Manufacturers' Parts or Drawing Numbers	Chapter 2- Sub-chap	Fig & Item
7360-G-100-101	2	NI 1
7360-G-100-201	2	NI 2
7360-G-100-601	2	NI 3
7360-G-100-711	2	NI 4
7360-G-100-741	2	NI 5
7360-G-100-811	2	NI 6
7360-G-100-821	2	NI 7

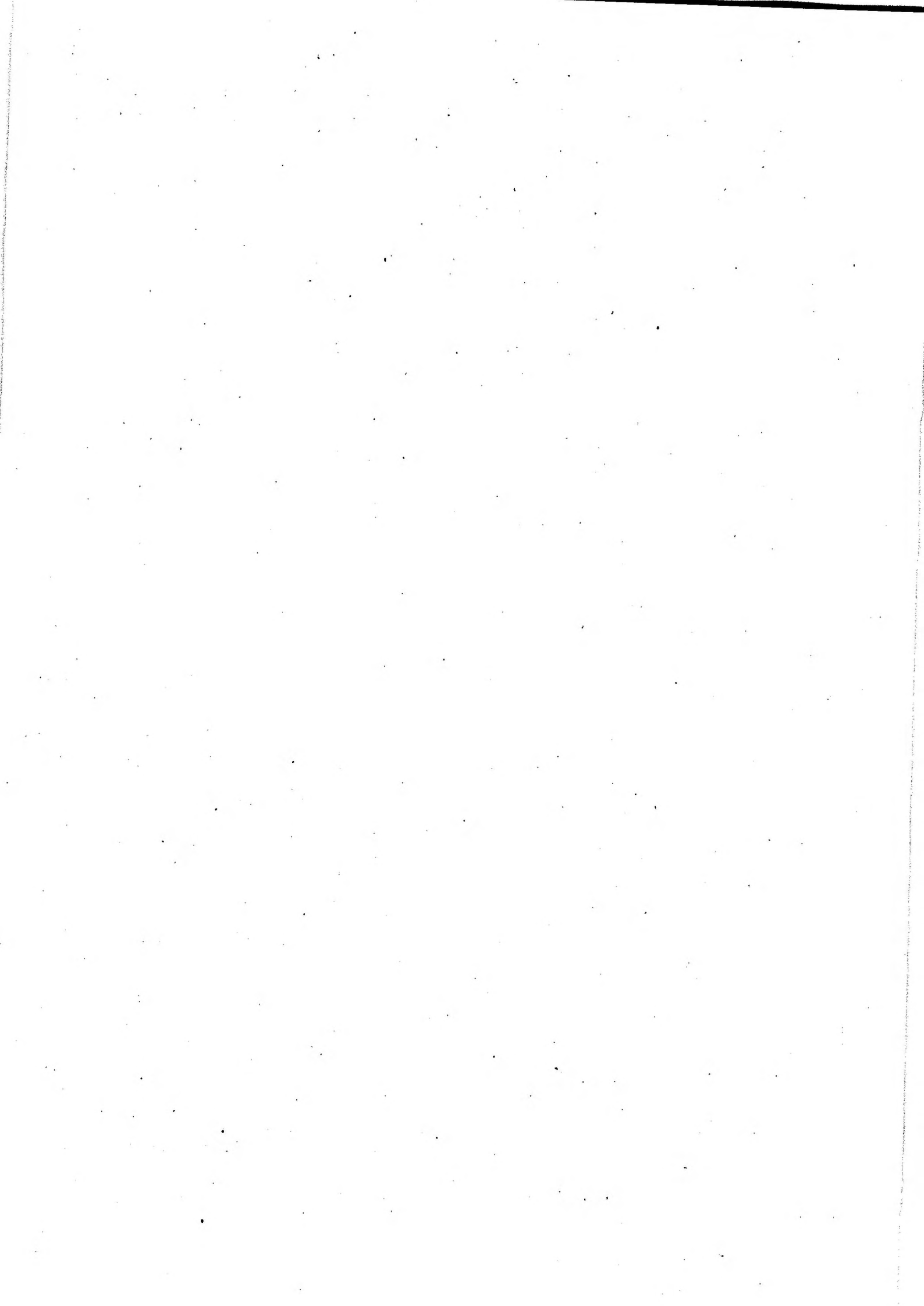

COMMENT(S) ON AESP*

To: ECI PT
MoD, Abbey Wood
Bristol
B34 8JH

From:

Senders Reference	BIN Number	Date
AESP* Title:		
Chapter(s)/Instruction	Page(s)/Paragraph(s)	
If you require more space please use the reverse of this form or a separate piece of paper.		
Comment(s):		

Signed: Telephone No:

Name (Capitals): Rank/Grade: Date:

X

FOR AESP* SPONSOR USE ONLY

To:

From:

Thank you for commenting on AESP 7360-G-100-741

Your reference: Date:

Action is being taken to:	Tick	Tick
Issue a revised/amended AESP*	<input type="checkbox"/>	Under investigation
Incorporate comment(s) in future amendments	<input type="checkbox"/>	No action required
Remarks		

Signed: Telephone No:

Name (Capitals): Rank/Grade: Date:

* AESP or EMER

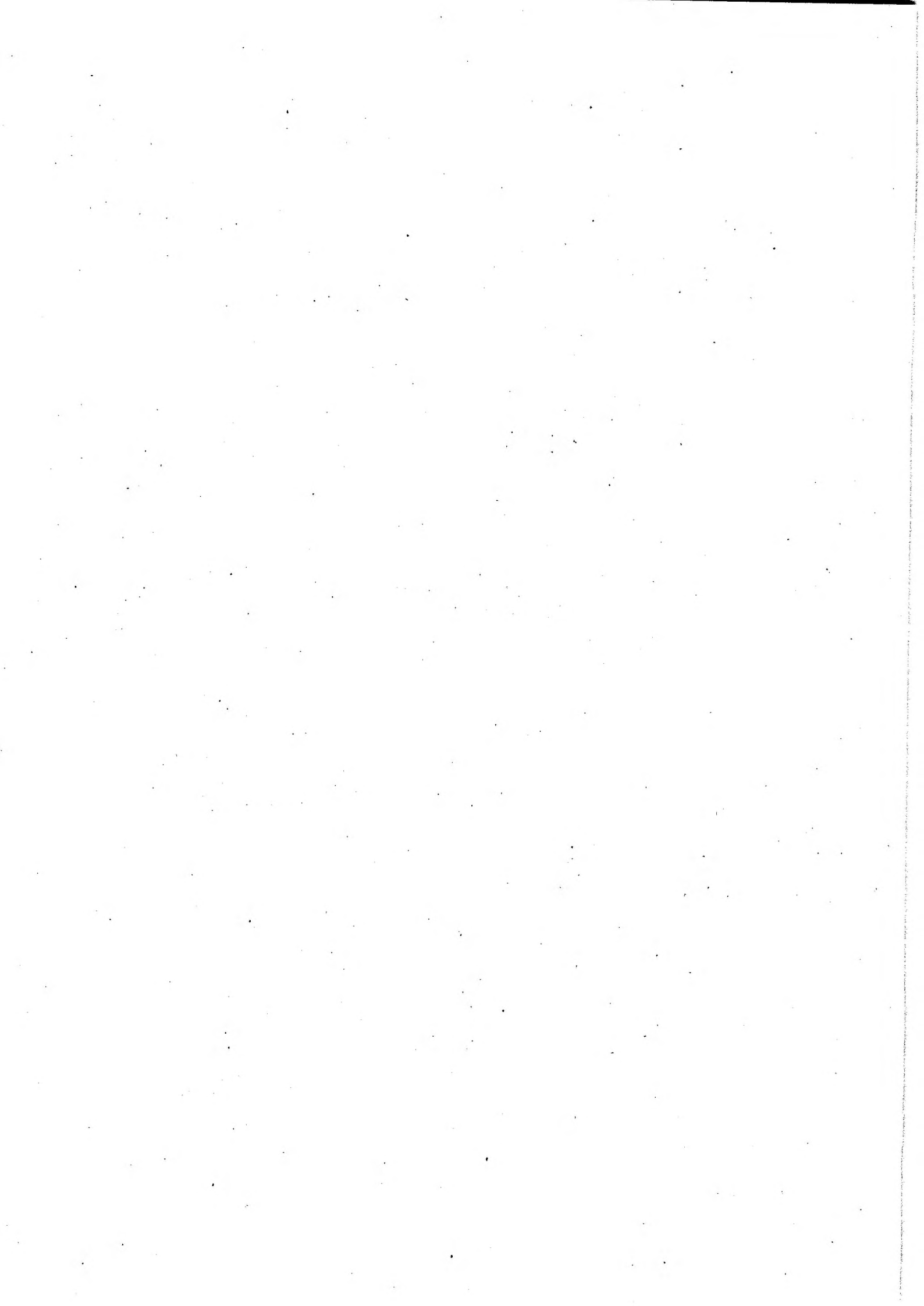



COOKING OUTFIT FIELD No. 5

MODIFICATION INSTRUCTIONS AND INDEX

Sponsored for use in the

**UNITED KINGDOM MINISTRY OF DEFENCE
AND ARMED FORCES**

by

**ECI PT
DE&S Abbey Wood
Bristol
BS34 8JH**

CONDITIONS OF RELEASE

~~This information is released by the UK government for Defence purposes only.~~

~~This information must be afforded the same degree of protection as that afforded to information of an equivalent classification originated by the recipient Government or as required by the recipient Government's National Security regulations.~~

~~This information may be disclosed only within the Defence Department of the recipient Government, except as otherwise authorized by the Ministry of Defence (Army).~~

This information may be subject to privately owned rights.

~~THIS DOCUMENT IS THE PROPERTY OF HER BRITANNIC MAJESTY'S GOVERNMENT, and is issued for the information of such persons only as need to know its contents in the course of their official duties. Any person finding this document should hand it in to a British forces unit or to a police station for its safe return to the Ministry of Defence, (DDef Sy), Main Building, Whitehall London, SW1A 2HB, with particulars of how and where found. THE UNAUTHORIZED RETENTION OR DESTRUCTION OF THIS DOCUMENT IS AN OFFENCE UNDER THE OFFICIAL SECRETS ACTS OF 1911-1989. (When released to persons outside Government service, this document is issued on a personal basis. The recipient to whom it is entrusted in confidence, within the provisions of the Official Secrets Acts 1911-1989, is personally responsible for its safe custody and for seeing that its contents are disclosed only to authorized persons.)~~

© CROWN COPYRIGHT RESERVED

AMENDMENT RECORD

Amdt No	Incorporated By (Signature)	Date
1		
2		
3		
4		
5		
6		
7		
8		
9		
10		
11		
12		
13		
14		
15		
16		
17		
18		
19		
20		
21		
22		
23		
24		
25		
26		
27		
28		
29		
30		
31		

Amdt No	Incorporated By (Signature)	Date
32		
33		
34		
35		
36		
37		
38		
39		
40		
41		
42		
43		
44		
45		
46		
47		
48		
49		
50		
51		
52		
53		
54		
55		
56		
57		
58		
59		
60		
61		
62		

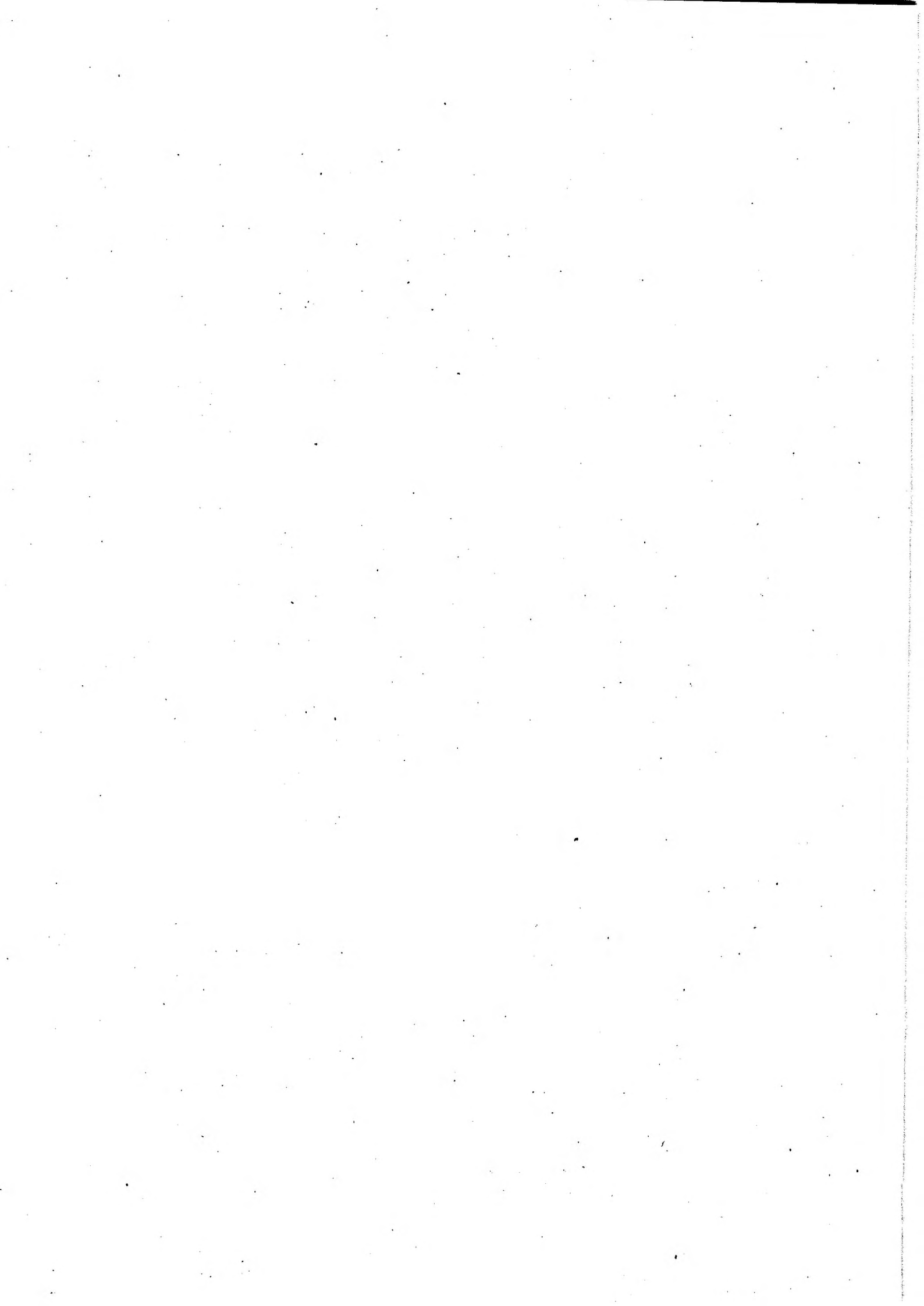

CONTENTS

	Page
PRELIMINARY MATERIAL	
Front cover (title page)	(i)
Conditions of release	(ii)
Amendment record sheet	(iii)/(iv)
Contents (this list)	(v)
PREFACE	(vi)
Introduction	(vi)
Related and associated publications	(vii)
Related publications	(vii)
Associated publications	(viii)
Abbreviations	(ix)
Warnings	(x)
Cautions	(x)
Comment on AESP	—Final leaf

PREFACE

SPONSOR: ECI PT

INTRODUCTION

- 1 The Publications Agency is responsible for the allocation of instruction numbers.
- 2 All instructions (when issued) are to be recorded in manuscript by the recipient on the Numerical Instruction Index provided. Amendments to individual instructions are to be recorded on the Instruction amendment record. All extant instructions and amendments can be found listed in the main AESP index.

NOTE

The Publications Agency is responsible for the preparation and maintenance of the Instruction Index and will advise the Distribution Authority on the issue of completed and subsequent blank index pages necessary.

- 3 Service users should forward any comments on this publication through the channels prescribed in AESP 01 00-P-01 1-013. An AESP Form 10 is provided after the preliminary pages of this publication; it should be photocopied and used for forwarding comments on this AESP.

MODIFICATION INSTRUCTION INDEX

Priority (Pty) is shown as: Immediate: I Routine: A

Inst No. (1)	Pty (2)	Page No. (3)	Amdt No (4)	Subject (5)	Approval No/ Remarks (6)
1	I	1-5/6		Fire extinguisher stowage	71312 (124)
2	I	4		Regulator fluid pressure J2/4820-99-1 32-357 1	28Y3 (21)
3	R	4		Oven assembly 7360-99-139-1505	72012 (163)
4	R	Refer to Mod Instr Sheet		Removal of all parts associated with the burning of petrol as a fuel	Mod Issued Jan 03

RELATED AND ASSOCIATED PUBLICATIONS

Related publications

4 The octad for the subject equipment consists of all the categories shown in Table 1. All references are prefixed with the first eight digits of this publication. The availability of the publications can be checked by reference to the relevant Group Index in AESP 0100-A-001-013.

TABLE 1 RELATED PUBLICATIONS

Category/Sub-Category		Information Level				
		1 User/Operator	2 Unit Maintenance	3 Field Maintenance	4 Base Maintenance	
1	0	Purpose and Planning Information	101	101	101	.
	1	Equipment Support Policy Directives
2	0	Operating Information	201	201	201	.
	1	Aide Memoire
	2	Training Aids
3		Technical Description	201	201	201	.
4	1	Installation Instructions
	2	Preparation for Special Environments
5	1	Failure Diagnosis	201	201	201	.
	2	Repair Instructions	201	201	201	.
	3	Inspection Standards	201	201	201	.
	4	Calibration Procedures
6		Maintenance Schedules	601	601	601	.
7	1	Illustrated Parts Catalogues	711	711	711	.
	2	Commercial Parts Lists	.	*721	.	.
	3	Complete Equipment Schedule, Production
	4	Complete Equipment Schedule, Service Edition (Simple Equipment)	741	.	.	.
	5	Complete Equipment Schedule, Service Edition (Complex Equipment)
8	1	Modification Instructions	811	811	811	.
	2	General Instructions, Special Technical Instructions and Servicing Instructions	821	821	821	.
	3	Service Engineered Modification Instructions (RAF only)

* Category/Sub-category not published.

Associated publications

- 5 The following associated publications should be read in conjunction with this publication:

Reference	Title
JSP 319	Joint Service Safety Regulations for the Storage and Handling of Liquefied Petroleum Gas (LPG)

EQUIPMENT IDENTITY

- 6 This publication covers the following:

6.1	Contract number:	N/A
6.2	Equipment title:	Cooking Outfit Field No. 5
6.3	NATO Stock Number:	J2/7360-99-1 32-2518
6.4	Asset code:	N/A

WARNINGS

- 7 The following WARNINGS are applicable to this equipment.

(1) **FUEL POLICY. THE COOKING OUTFIT SHOULD ONLY BE USED WITH LIQUEFIED PETROLEUM GAS (LPG) AS A FUEL. GASOLINE HAS BEEN BANNED. ALSO THE USE OF FILTER GENERATORS (FG) NSN 7360-99-132-3584 HAS BEEN PROHIBITED.**

(2) **PERSONNEL INJURY. THE FIRE EXTINGUISHER MUST NOT BE STOWED IN THE COOKER.**

(3) **PERSONNEL INJURY. HANDLES ARE FITTED TO THE OVEN. THESE HANDLES MUST BE USED WHEN MOVING OR LIFTING A WARM OVEN.**

(4) **PERSONNEL INJURY. LPG IS HIGHLY FLAMMABLE. NO SMOKING OR NAKED FLAMES ARE PERMITTED IN THE VICINITY OF THE COOKING OUTFIT WHEN CONNECTING OR DISCONNECTING GAS CYLINDERS.**

CAUTIONS

- 8 There are no CAUTIONS applicable to this equipment.

COOKING OUTFIT NO 5

MODIFICATION INSTRUCTION NO 1

Sponsor:
DGEME(A)

Publications Authority:
Vehicles and Weapons Branch REME
Project No: 71312(124)
File ref: CS/400

AMENDMENT RECORD

Amdt	Incorporated by	Date

Amdt	Incorporated by	Date

SUBJECT: FIRE EXTINGUISHER STOWAGE

INTRODUCTION

1 This instruction details the welding of a bar across the defunct fire extinguisher stowage in the cooker, to prevent unauthorised stowage.

1.1 Limitations on use of equipment. NIL

APPLICABILITY

2 Field Cooking Outfit No 5 — 7360-99-132-2518

2.1 Fitted to subject equipment held by user units.

2.2 Unmodified stock, held in RAOC and technical stores.

REASON FOR MODIFICATION

3 Code 1 — to improve safety

PRIORITY

4 Immediate

ESTIMATED TIME REQUIRED

5 Embodiment: 1.0 man-hours

MODIFICATION IMPLEMENTATION PLAN

6 This modification is to be implemented by units authorised to carry out levels 2, 3 and 4 maintenance.

6.1 Associated modification instructions. Nil

6.2 Modification plate strike action: NA

7 Action required by:

7.1 Units and establishments holding equipment

7.1.1 Examine equipment documents to see if modification is applicable.

7.1.2 Examine equipment or modification record plate to see if modification is embodied and where necessary demand the stores required.

7.2 On receipt of stores, request REME to modify equipment.

7.3 Record the modification AESP number and Army Modification Code in equipment documents.

7.4 Units authorised to carry out levels 2, 3 and 4 maintenance

7.4.1 When requested by users or during overhaul, obtain the items listed in para 8 and carry out this modification.

7.4.2 Record completion details of modification against appropriate entry in equipment documents. -

8. Complete AF G1084A when reporting completion of the modification to Data Centre using the following FORWARD codes:

EQUIPMENT CODE: Refer to Mgmt J 022
MODIFICATION CODE: NN0000

8.1 All recipients of this instruction.

8.1.1 Add particulars to AESP 7360-G-100-811 Mod Instr Index.

Stores, tools and equipment

9 The following stores or suitable equivalent are to be obtained locally

Item No	COSA Section	NSN/ Part No	Designation	Qty per eqpt
1	G2	9515-99-964-7275	Steel strip 12 x 3 mm thk	A/R
2			Paint IRR green	A/R

Sequence of operations

NOTE

The item numbers used are the Item numbers as listed at para 8.

10 Carry out the modification as follows:

10.1 Measure and cut steel strip (1) to length to fit across stowage as shown in Fig 1.

10.2 File radius on edges of bar to leave smooth.

10.3 Mark out position of bar on cook set as per Fig 2. Weld bar in position flush with side of cooker body in accordance with EMER Wksp 0360.

10.4 Clean, prepare and paint in accordance with EMER G 500.

Testing after embodiment

11 Nil

EFFECT ON WEIGHT

12 Negligible

PUBLICATION AMENDMENTS

13 Nil

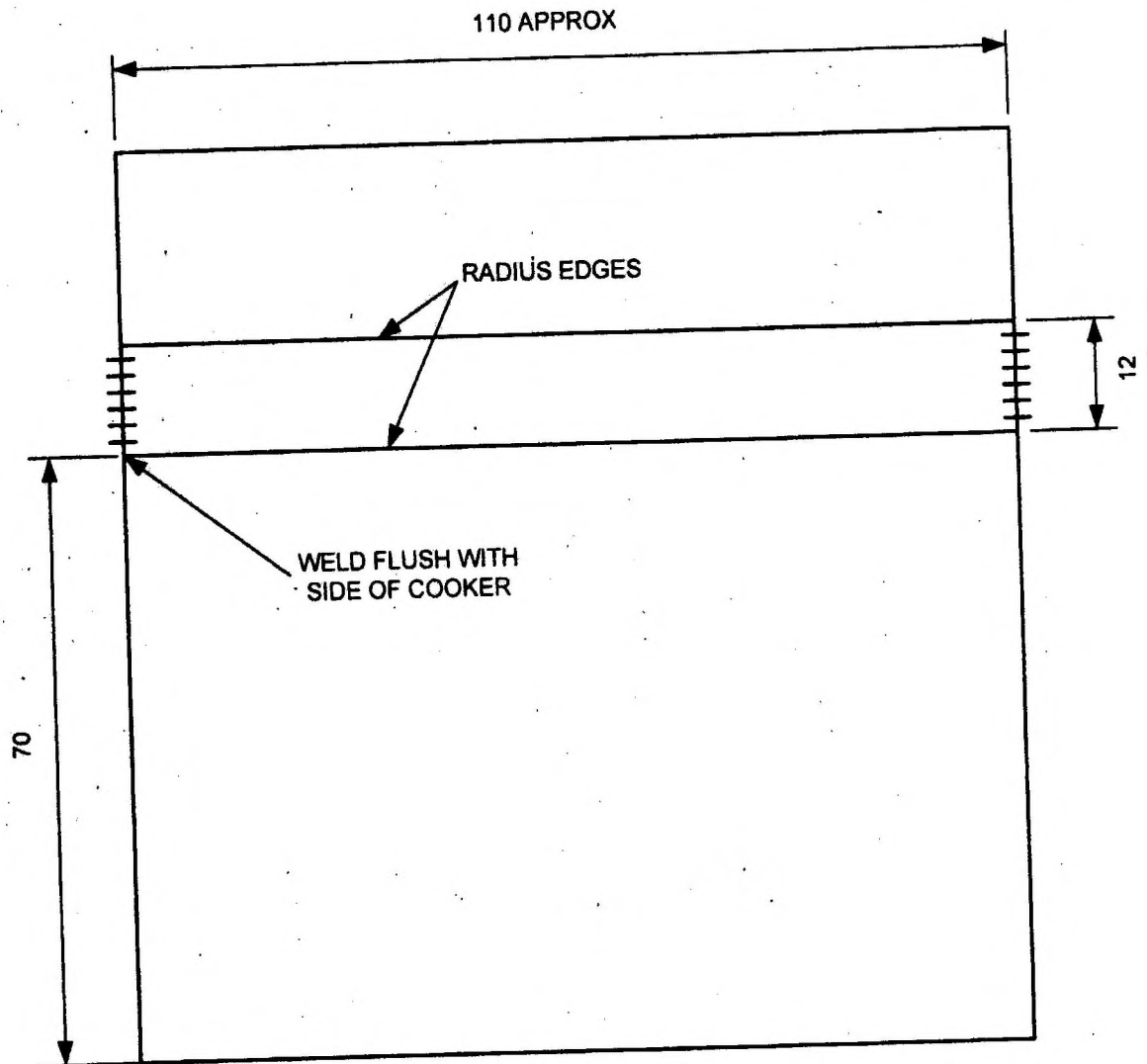

WELD IN ACCORDANCE WITH EMER WKSP 0-360

Fig 1 Detail of bar position

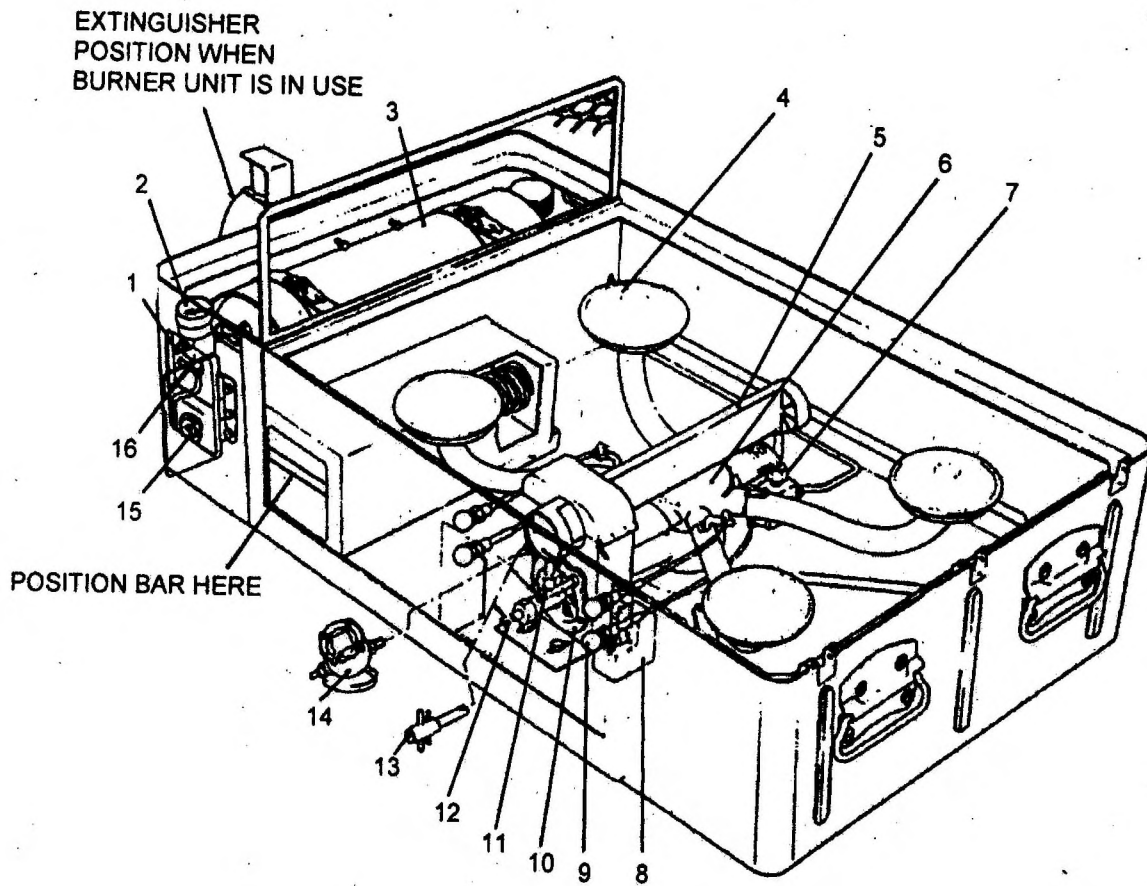

Fig 1 Position of bar

COOKING OUTFIT, NO 5

MODIFICATION INSTRUCTION NO 2

Sponsor:
DGEME(A)

Publications Authority:
Vehicles and Weapons Branch REME
Project No: 71312(124)
File ref: CS/400

AMENDMENT RECORD

Amdt	Incorporated by	Date

Amdt	Incorporated by	Date

SUBJECT: REGULATOR FLUID PRESSURE - J2 4820-99-132-3571

INTRODUCTION

1 To ensure that the cookset regulator is set correctly, and cannot be reset to an incorrect pressure in use, the regulator is to be sealed.

1.1 Limitations on use of equipment: Nil

APPLICABILITY

2 Regulator, Fluid Pressure NSN J2 4820-99-132-3571

2.1 Fitted to subject equipment held by user units.

2.2 Unmodified stock held in RAOC and technical stores.

REASON FOR MODIFICATION

3 Code 1 — Safety

PRIORITY

4 ARMY: Immediate

ESTIMATED TIME REQUIRED

5 Embodiment: 0.75 man-hours

MODIFICATION IMPLEMENTATION PLAN

6 This modification is to be implemented by ARMY Units authorised to carry out levels 3 and 4 repairs and by vehicle depots before issue of equipment.

6.1 Associated modification instructions. Nil

6.2 Modification plate strike action: NA

7 Action required by:

7.1 Units and establishments holding equipment

- 7.1.1 Examine equipment documents to see if modification is applicable.
- 7.1.2 Examine equipment to see if modification is embodied.
- 7.1.3 ARMY — Request REME to modify equipments.
- 7.1.4 ARMY — Record the modification, AESP Number and modification code in equipment document.

7.2 Units authorised to carry out levels 3 and 4 repairs.

7.2.1 ARMY — When requested by users or during overhaul of equipments on charge without REME 1st Line Support obtain the items listed in Para 8 and carry out this modification.

7.2.2 Record completion details of modification against appropriate entry in equipment documents.

7.2.3 Complete AF G1084A when reporting completion of the modification to Data Centre using the following FORWARD code:

EQUIPMENT CODE: Refer to Mgmt J 022
MODIFICATION CODE: NN0000

7.3 All recipients of this instruction.

7.3.1 Add particulars to AESP 7360-G-100-811 Mod Instr Index.

Stores, tools and equipment

8 The following stores or suitable equivalent are to be obtained locally

Item No	COSA Section	NSN/ Part No	Designation	Qty per eqpt
1	G2	5340-99-120-7737	Seal, lead	1

Sequence of operations

NOTE

The item numbers quoted refer to the items as listed at Para 8.

9 Carry out the modification as follows:

- 9.1 Set regulator valve running pressure to .0.7 kg/cm².
- 9.2 Drill 2 mm hole through both regulator body and setting screw, in accordance with Fig.1.
- 9.3 Insert lead seal through and round regulator valve, and crimp seal with sealing pliers.
 - 9.3.1 Re-check running pressure.

Testing after embodiment

10 Nil

EFFECT ON WEIGHT

11 Nil

PUBLICATION AMENDMENTS

12 AESP 7360-G-100-201

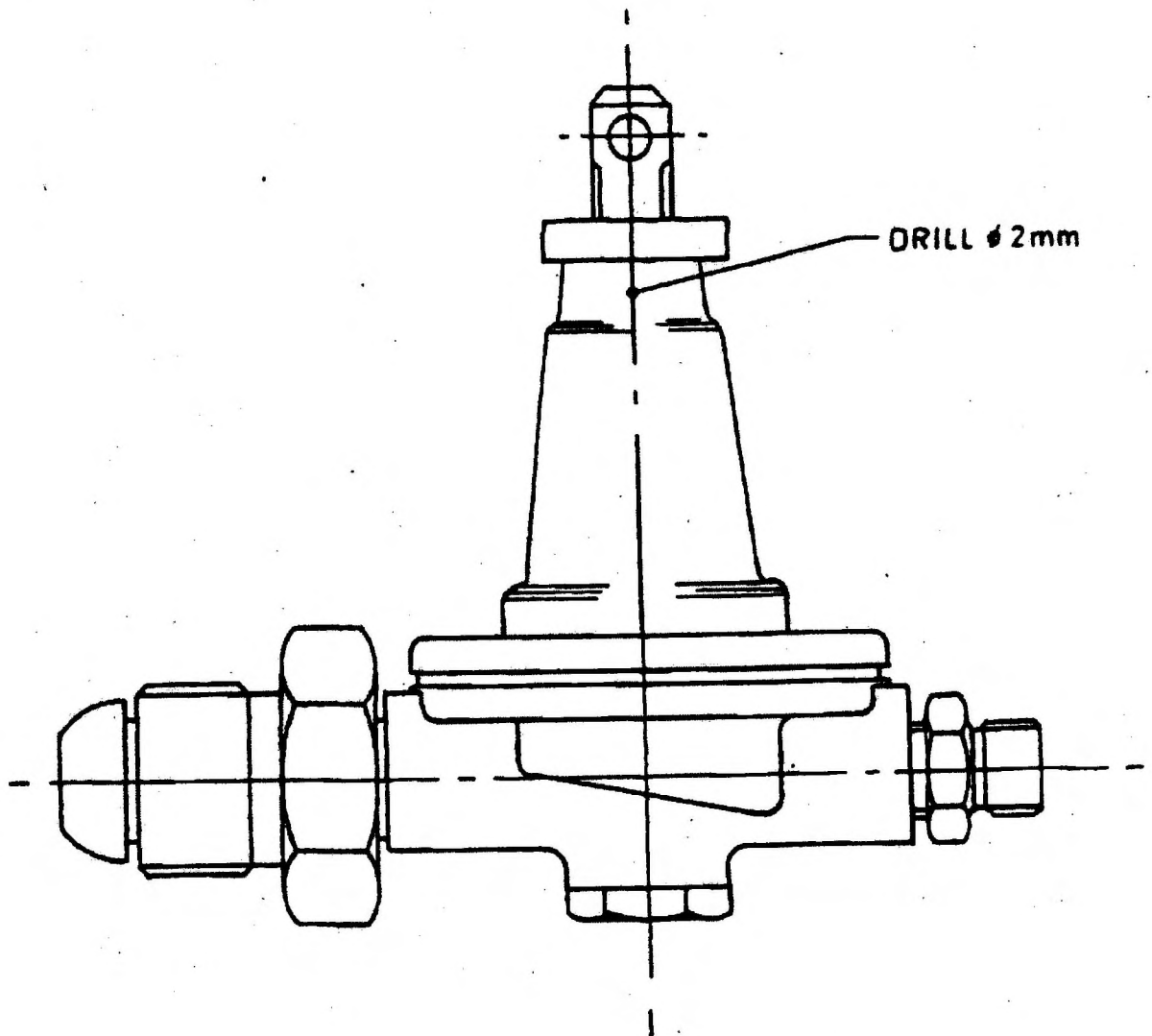
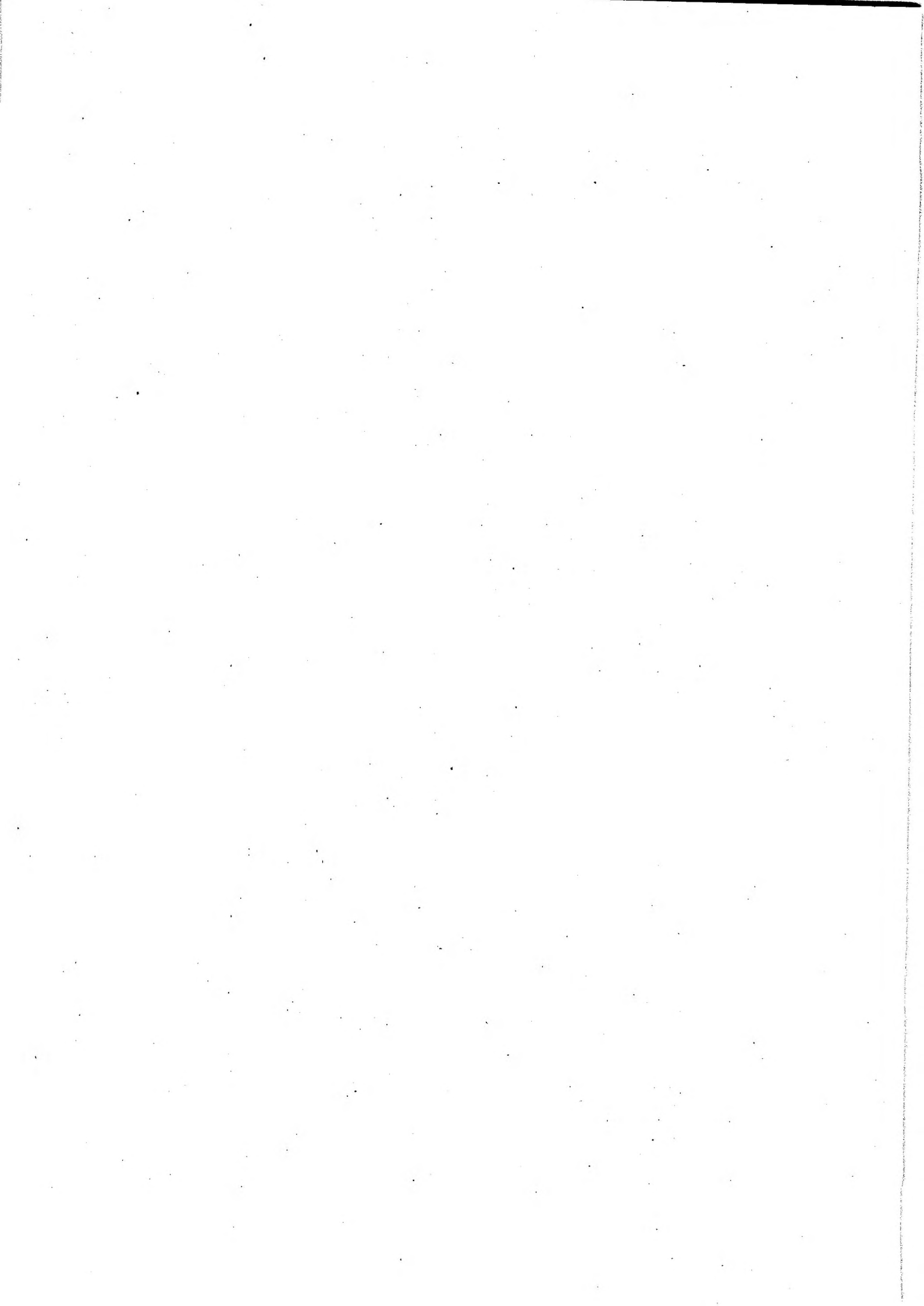

Fig 1 Drilling detail



COOKING OUTFIT, NO 5

MODIFICATION INSTRUCTION NO 3

Sponsor:
DGES(A)

Publications Authority:
ATSA Chertsey
Project No: 72012(163)
File ref. KCOI

AMENDMENT RECORD

Amdt	Incorporated by	Date

Amdt	Incorporated by	Date

SUBJECT: OVEN ASSEMBLY – 7360-99-139-1505

INTRODUCTION

- 1 This instruction details the fitting of carrying handles to the subject ovens:
 - 1.1 Limitations on use of equipment Nil.

APPLICABILITY

- 2 Oven assembly – 7360-99-139-1505
 - 2.1 Fitted to subject equipment held by user units.
 - 2.2 Unmodified stock held at all levels.

REASON FOR MODIFICATION

- 3 Code 6 – other reasons

PRIORITY

- 4 The following priorities are applicable:
 - 4.1 ARMY: Routine.
 - 4.2 RAF: Class 3

ESTIMATED TIME REQUIRED

- 5 Embodiment: 1 man-hour

MODIFICATION IMPLEMENTATION PLAN

- 6 This modification is to be implemented by:
 - 6.1 ARMY Units authorised to carry out levels 3 and 4 repairs
 - 6.2 RAF Units not later than the next maintenance
 - 6.3 Vehicle depots before issue of equipment.

7 Action required by:

7.1 Units and establishments holding equipment

7.1.1 Examine equipment documents to see if the modification is applicable.

7.1.2 Examine equipment or modification record plate to see if the modification is embodied and where necessary Units with 1st line REME support demand the stores required.

7.1.3 ARMY - On receipt of stores, request REME to modify the equipment.

7.1.4 ARMY - Record the modification subject and AESP Number in equipment document

7.1.5 RAF - Record modification details on AF G1084A and Form 4870.

7.2 Army Units authorised to carry out levels 2, 3 and 4 maintenance and RAF Units:

7.2.1 ARMY - When requested by users or during overhaul of equipments on charge without REME 1st line support, obtain the items listed in Para 8 and carry out this modification..

7.2.2 Record completion details of modification against appropriate entry in vehicle documents.

7.2.3 Complete AF G1084A when reporting completion of the modification to FORWARD (RAF).

7.3 All recipients of this instruction.

7.3.1 Add particulars to AESP 7360-G-100-811 Mod Instr Index.

Stores, tools and equipment

8 The following items are to be demanded quoting this instruction as authority

Item No	COSA Section	NSN/ Part No	Designation	Qty per eqpt
1	G1	5340-99-432-7198	Handle	2
2	G1	5340-99-941-7281	Rivet	12

Sequence of operations**NOTE**

The 'item numbers' of Para 8 are to be used as reference throughout this instruction.

9 Carry out this modification as follows:

9.1 Referring to Fig I, mark out handles and drill holes 4.8 mm.

9.2 Mark out centre line on each end of oven and centre pop position of upper hole.

9.3 Drill upper holes in oven, and rivet handle in position.

9.4 Using handle as a template drill lower of the centre holes and rivet.

9.5 Drill remaining four holes in oven using handle as template and complete the riveting.

ARMY EQUIPMENT
SUPPORT PUBLICATION

Testing after embodiment

10 Nil.

EFFECT ON WEIGHT

11 Negligible.

PUBLICATION AMENDMENTS

NOTE

Necessary amendments will be issued separately.

12 Nil.

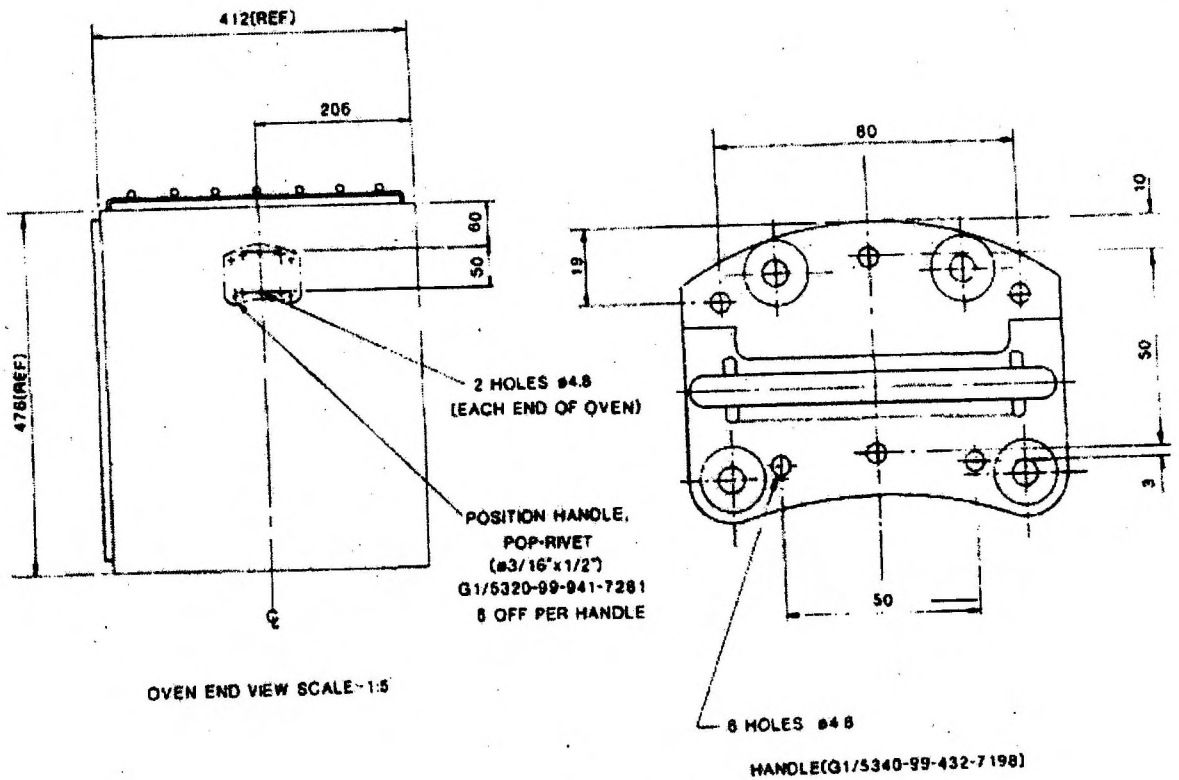
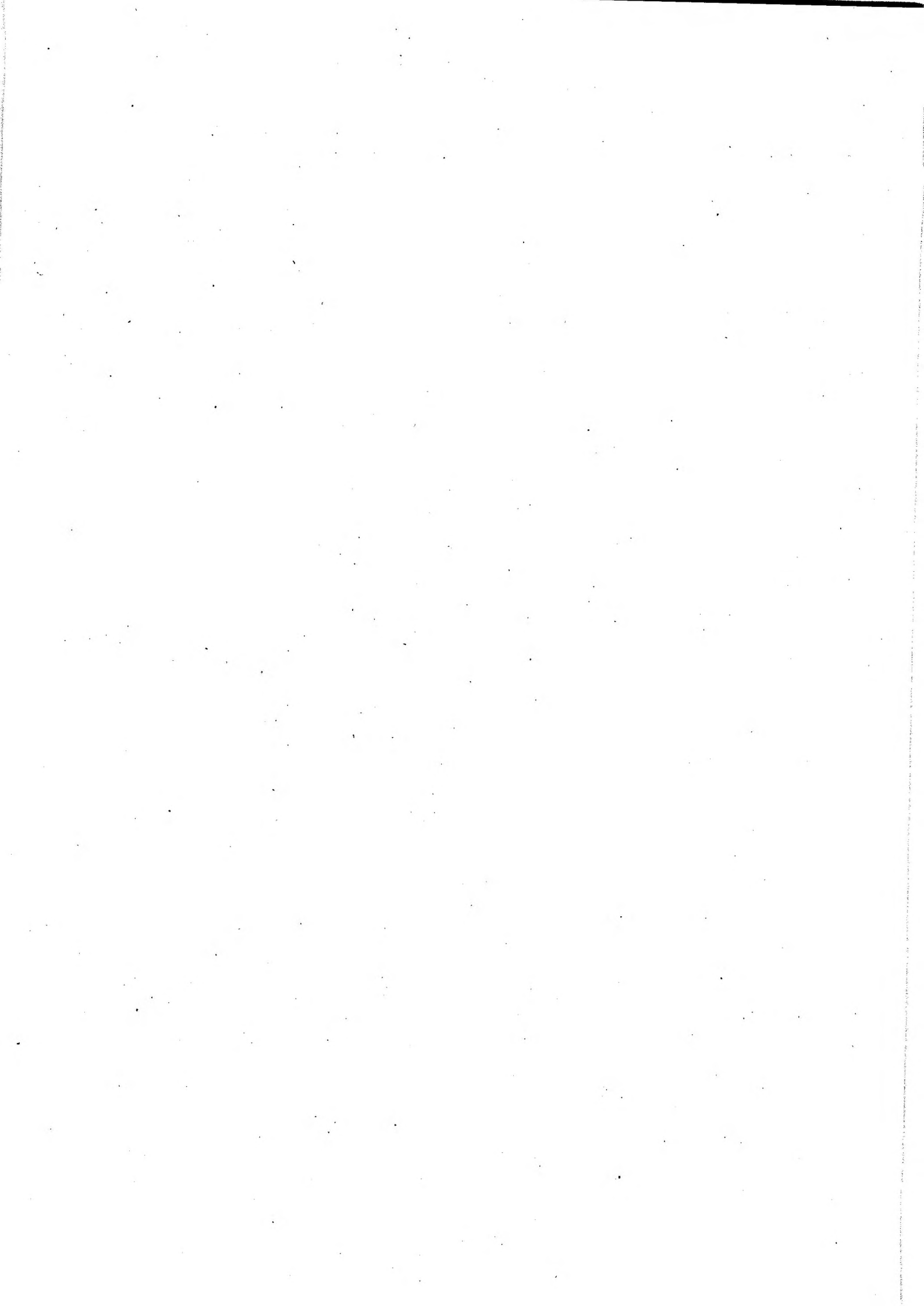

Fig 1 Handle



COOKING OUTFIT, NO 5

MODIFICATION INSTRUCTION NO 4

Sponsor:
DGES(A)

Publications Authority:
ECI PT
Abbey Wood

AMENDMENT RECORD

Amdt	Incorporated by	Date

Amdt	Incorporated by	Date

SUBJECT: COOKER, FIELD COOKING NO 5 - 7360-99-132-4561

INTRODUCTION

1 This instruction details the modification of the No.5 cookset by removing petrol-burning components.

1.1 Limitations on use of equipment: Will only burn LPG as a fuel after modification.

APPLICABILITY

2 Cooker, Field Cooking Outfit No5.

2.1 Held by user units.

2.2 Unmodified stock, held at all levels of storage

REASON FOR MODIFICATION

3 Code 1 - to improve safety.

PRIORITY

4 Priorities are as follows:

4.1 ARMY: Routine.

4.2 RAF: Class 3.

ESTIMATED TIME REQUIRED

5 Estimated times are as follows:

5.1 Dismantling: 4 man-hours.

5.2 Embodiment: ½ man-hour

5.3 Testing: ½ man hour

MODIFICATION IMPLEMENTATION PLAN

- 6 This instruction is to be implemented by:
- 6.1 ARMY - Units authorized to carry out levels 2, 3 or 4 maintenance.
 - 6.2 RAF - Units not later than the next planned maintenance.
- 7 Action required by:
- 7.1 Units and establishments holding equipment:
 - 7.2 Examine equipment documents to see if modification is applicable.
 - 7.3 Examine equipment or modification records to see if modification is embodied and where necessary Units with 1st Line REME Support demand the stores required.
 - 7.4 ARMY - On receipt of stores, request REME to modify equipment.
 - 7.5 ARMY - Record the AESP and instruction number in equipment documents.
 - 7.6 RAF - Record modification details on AF G1084A and Form 4870.
- 8 Army units authorized to carry out levels 2, 3 and 4 maintenance and RAF units:
- 8.1 ARMY - When requested by units or during overhaul of equipment on charge without REME 1st Line Support, obtain the items listed in Para 8 and carry out this modification.
 - 8.2 ARMY — record completion details of modification against appropriate entry in documents
 - 8.3 Complete AF G1084A when reporting completion of the modification to FORWARD (RAF).
- 9 All recipients of this instruction.
- 9.1 Add particulars to AESP 7360-G-100-811 MoD Inst. Index.

STORES, TOOLS AND EQUIPMENT

- 10 The following item is to be demanded quoting this instruction as the authority:

Item No	COSA Section	NSN/ Part No	Designation	Qty per eqpt
1	J2	7360-99-593-2127	Plate Instruction Cooking Outfit Field No5	1

- 11 The following stores or suitable equivalent to be obtained locally:
- 11.1 None
- 12 The following tools and stores are to be manufactured:
- 12.1 None
- 13 The following stores are to be removed and returned through normal channels/reduced to scrap:
- 13.1 Scrap all items removed.
- 14 The following Items/stores are to be modified:
- 14.1 J2 7360-99-593-2127

15 The following Special tools and test equipment are required:

15.1 None

SEQUENCE OF OPERATIONS

NOTE

The item numbers of para 10 are used as reference throughout this instruction.

16 Carry out this instruction as follows using AESP 7360-G-100-711 for Figure and Item reference:

16.1 Remove cooker from fuel supply.

16.2 Remove Filter Generator and Hood. Refer to Fig 2, Items 17 and 64 (retaining control valve complete).

16.3 Remove Fuel Transfer block plus pipe work for Main Feed. Refer to Fig 2 item 30 consisting of items 31, 32, 33, 34, 35, 36 and 37. Also remove Plug Blanking used on fuel transfer block, item 65 consisting of items 48, 49 and 50 (located at rear of burner). Remove Pre-Heater valve assembly complete. Refer to Figure 2 item 46 consisting of 38, 39, 40, 41, 42, 43, 44 and 45. Also remove tray assembly item 47.

16.4 Remove Fuel Tank, Cradle, Tank Block, Connector plus all associated pipework, brackets, gauges and valves. Refer to Fig 3-Remove all items shown in this Figure.

16.5 Affix new lighting instructions plate (para 8.1 item 1) in same position on cooker front drop flap having firstly removed old label if possible to do so.

16.6 Refit control valve in LPG position.

TESTING AFTER EMBODIMENT

17 Carry out leak test procedure and then light up normally.

EFFECT ON WEIGHT

18 Reduction.

PUBLICATION AMENDMENTS

19 Necessary amendments will be issued separately.

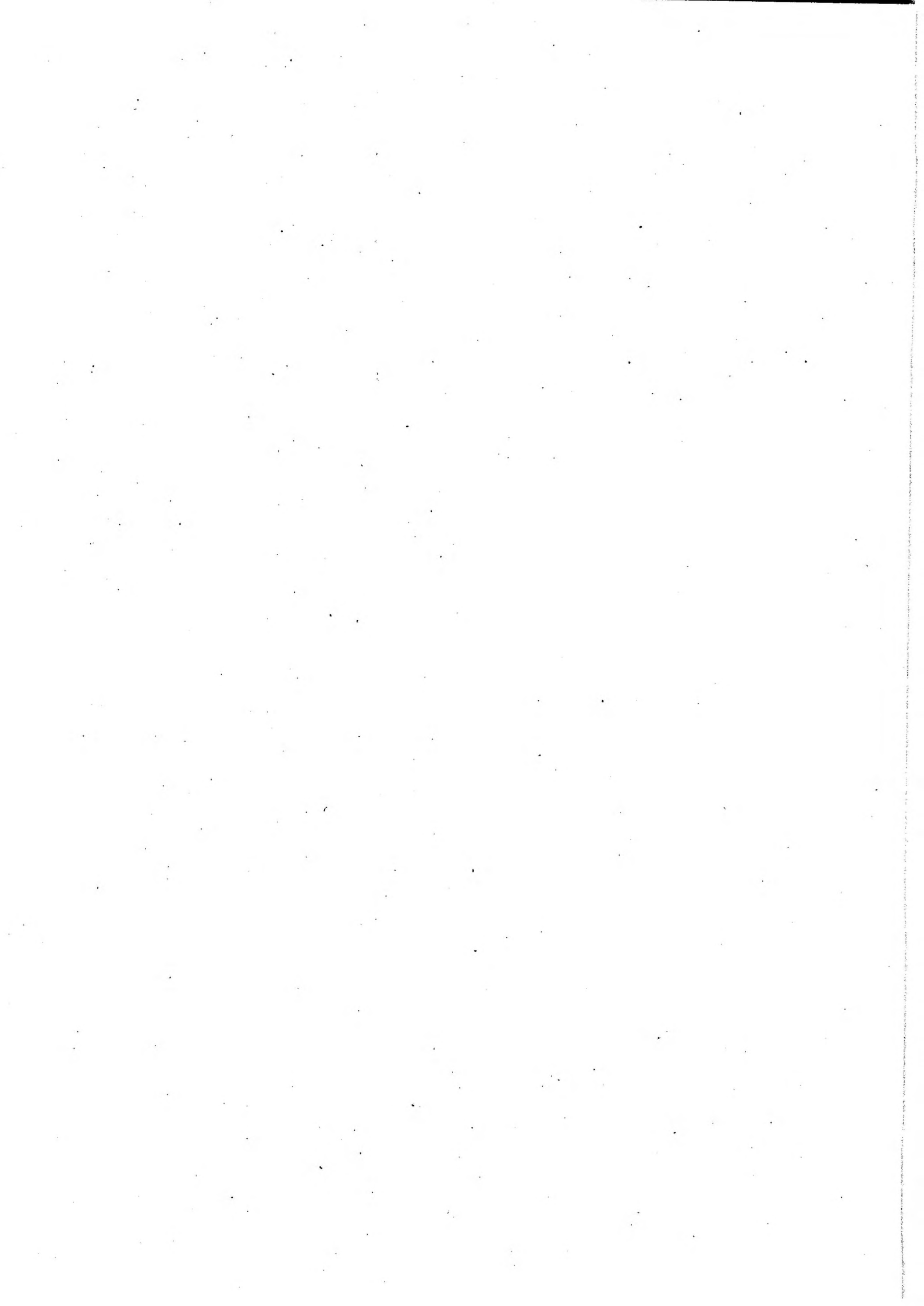

COMMENT(S) ON AESP*

To: ECI PT
MoD, Abbey Wood
Bristol
B34 8JH

From:
.....
.....

Senders Reference	BIN Number	Date
AESP* Title:		
Chapter(s)/Instruction	Page(s)/Paragraph(s)	
If you require more space please use the reverse of this form or a separate piece of paper. Comment(s):		

Signed: Telephone No:

Name (Capitals): Rank/Grade: Date:

X

FOR AESP* SPONSOR USE ONLY

To: From:
.....
.....

Thank you for commenting on AESP*

Your reference: Date:

Action is being taken to:	Tick	Tick
Issue a revised/amended AESP*		Under investigation
Incorporate comment(s) in future amendments		No action required
Remarks		

Signed: Telephone No:

Name (Capitals): Rank/Grade: Date:

* AESP or EMER

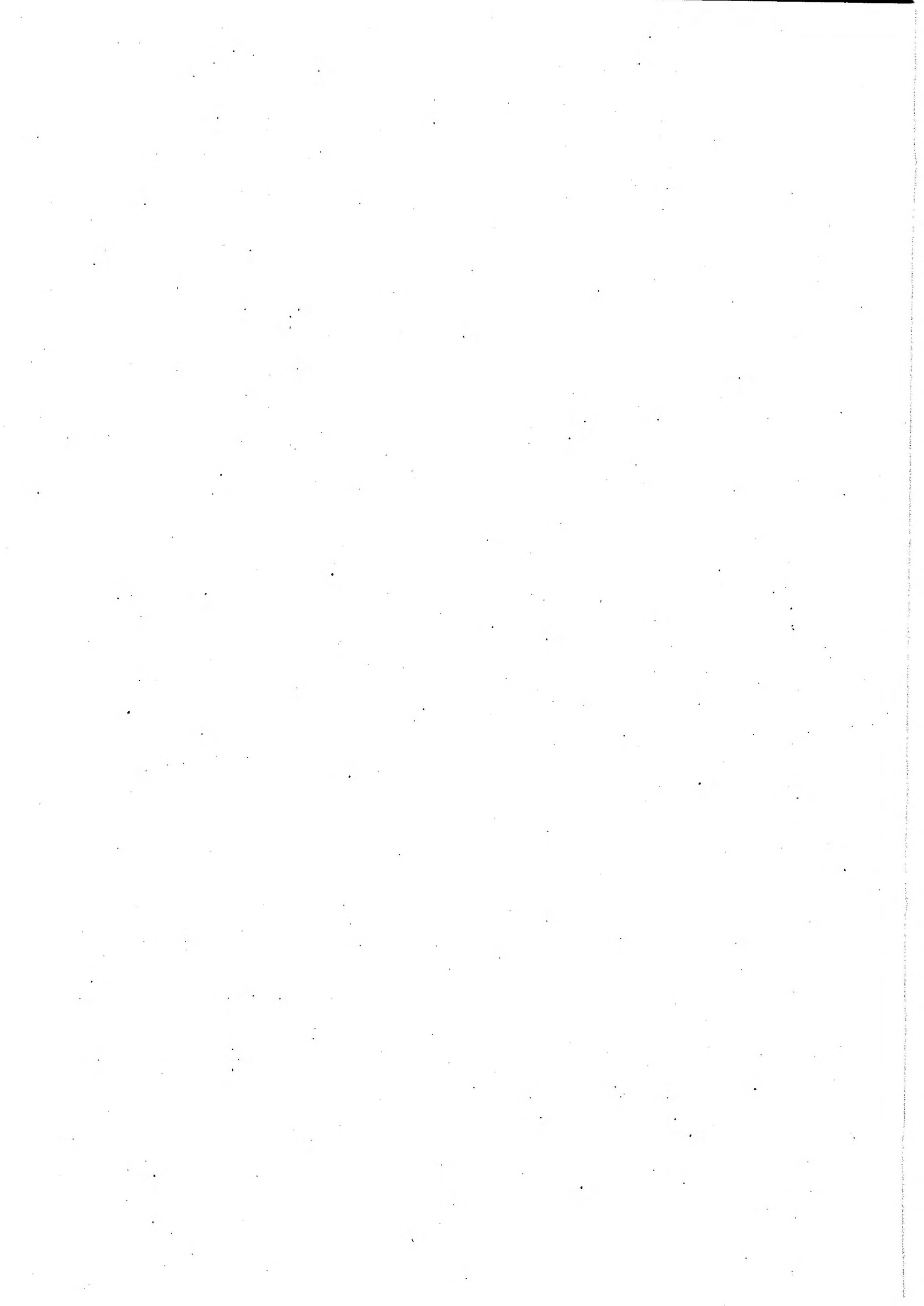



COOKING OUTFIT FIELD No. 5

GENERAL INSTRUCTIONS AND INDEX

Sponsored for use in the
UNITED KINGDOM MINISTRY OF DEFENCE
AND ARMED FORCES
by

ECI PT
DE&S Abbey Wood
Bristol
BS34 8JH

CONDITIONS OF RELEASE

~~This information is released by the UK government for Defence purposes only.~~

~~This information must be afforded the same degree of protection as that afforded to information of an equivalent classification originated by the recipient Government or as required by the recipient Government's National Security regulations.~~

~~This information may be disclosed only within the Defence Department of the recipient Government, except as otherwise authorized by the Ministry of Defence (Army).~~

~~This information may be subject to privately owned rights.~~

~~THIS DOCUMENT IS THE PROPERTY OF HER BRITANNIC MAJESTY'S GOVERNMENT, and is issued for the information of such persons only as need to know its contents in the course of their official duties. Any person finding this document should hand it in to a British forces unit or to a police station for its safe return to the Ministry of Defence, (DDef Sy), Main Building, Whitehall London, SW1A 2HB, with particulars of how and where found. THE UNAUTHORIZED RETENTION OR DESTRUCTION OF THIS DOCUMENT IS AN OFFENCE UNDER THE OFFICIAL SECRETS ACTS OF 1911-1989. (When released to persons outside Government service, this document is issued on a personal basis. The recipient to whom it is entrusted in confidence, within the provisions of the Official Secrets Acts 1911-1989, is personally responsible for its safe custody and for seeing that its contents are disclosed only to authorised persons.)~~

© CROWN COPYRIGHT RESERVED

AMENDMENT RECORD

Amdt No	Incorporated By (Signature)	Date
1		
2		
3		
4		
5		
6		
7		
8		
9		
10		
11		
12		
13		
14		
15		
16		
17		
18		
19		
20		
21		
22		
23		
24		
25		
26		
27		
28		
29		
30		
31		

Amdt No	Incorporated By (Signature)	Date
32		
33		
34		
35		
36		
37		
38		
39		
40		
41		
42		
43		
44		
45		
46		
47		
48		
49		
50		
51		
52		
53		
54		
55		
56		
57		
58		
59		
60		
61		
62		



CONTENTS

	Page
PRELIMINARY MATERIAL	
Front cover (title page)	(i)
Conditions of release	(ii)
Amendment record sheet	(iii)/(iv)
Contents (this list)	(v)
PREFACE	(vi)
Introduction	(vi)
Related and associated publications	(vii)
Related publications	(vii)
Associated publications	(viii)
Abbreviations	(ix)
Warnings	(x)
Cautions	(x)
Comment on AESP	—Final leaf

PREFACE

SPONSOR: ECI PT

INTRODUCTION

- 1 The Publications Agency is responsible for the allocation of instruction numbers.
- 2 All instructions (when issued) are to be recorded in manuscript by the recipient on the Numerical Instruction Index provided. Amendments to individual instructions are to be recorded on the Instruction amendment record. All extant instructions and amendments can be found listed in the main AESP index.

NOTE

The Publications Agency is responsible for the preparation and maintenance of the Instruction Index and will advise the Distribution Authority on the issue of completed and subsequent blank index pages necessary.

- 3 Service users should forward any comments on this publication through the channels prescribed in AESP 01 00-P-01 1-013. An AESP Form 10 is provided after the preliminary pages of this publication; it should be photocopied and used for forwarding comments on this AESP.

GENERAL INSTRUCTION INDEX

Priority (Pty) is shown as: Immediate: I Routine: A

Inst No. (1)	SI/STI No (2)	Subject (3)	Approval No/ Remarks (4)
1		Air shutter control	71212 (341)
2		Fuel supply hose NSN J2/4720-99-977-7482	72012 (116)
3		Insecure oven liners	72012 (166)
4		Replacement control valve packing	72112 (237)

COOKING OUTFIT NO 5

GENERAL INSTRUCTION NO 1

Sponsor:
DGEME(A)

Publications Authority:
Vehicles and Weapons Branch REME
Project No: 71212(341)
File ref: CS/400

AMENDMENT RECORD

Amdt	Incorporated by	Date

Amdt	Incorporated by	Date

SUBJECT: AIR SHUTTER CONTROL

INTRODUCTION

- 1 This instruction details the procedure for welding the air shutter control gear to the drive shaft.
 - 1.1 Limitations on use of equipment. NIL

APPLICABILITY

- 2 Field Cooking Outfit No 5 — 7360-99-132-2518
 - 2.1 Fitted to subject equipment held by user units.
 - 2.2 Unmodified stock, held in RAOC and technical stores.

ITEMS AFFECTED

- 3 Air shutter control — AESP 7360-G-100-201, Chap 1, Pages 3, Fig 1, item 11.

REASON FOR INSTRUCTION

- 4 Code 2 — to improve operational performance

ESTIMATED TIME REQUIRED

- 5 Embodiment: 1.0 man-hours

IMPLEMENTATION

- 6 This instruction is to be implemented by units authorised to carry out levels 2, 3 and 4 maintenance.
- 7 Associated modification instructions. Nil

DETAIL

- 8 Instances of the air shutter control failing to work have been caused by the drive gear becoming detached from its drive shaft. If this occurs the following action should be taken:

- 8.1 Remove the control valve assembly to gain access to gear and shaft. See Fig 1.

- 8.2 Braze gear to shaft as detailed in Fig 2.
- 8.3 Reassemble and functional test cooker.

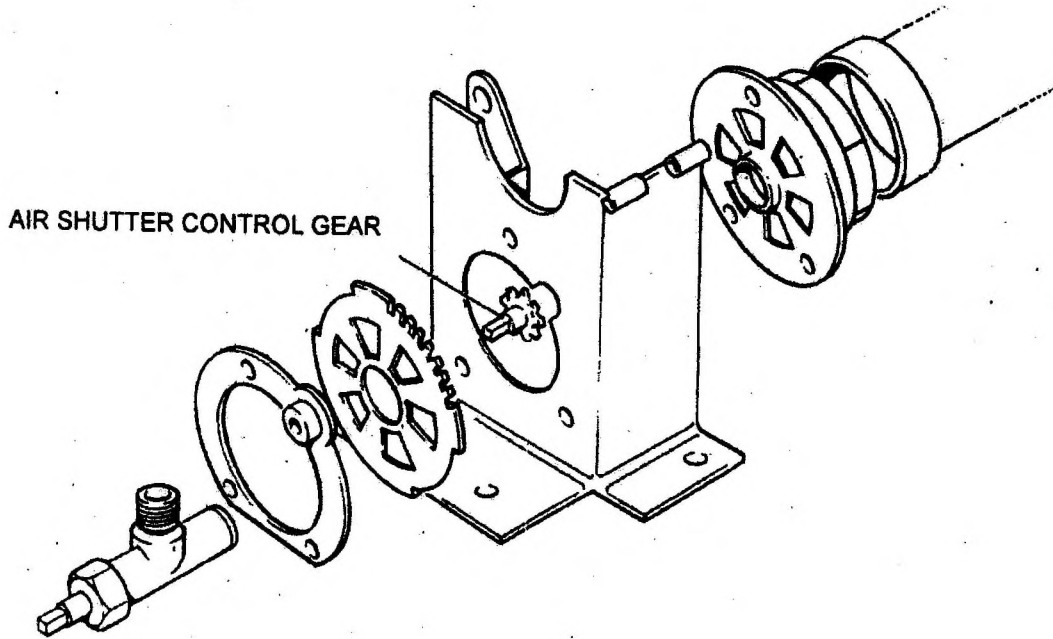

Fig 1 Air shutter control

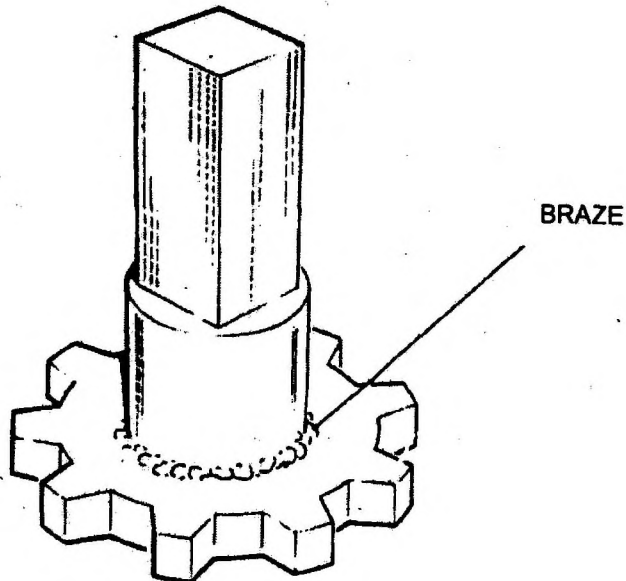

Fig 1 Air shutter control gear

COOKING OUTFIT NO 5

GENERAL INSTRUCTION NO 2

Sponsor:
DGEME(A)

Publications Authority:
Vehicles and Weapons Branch REME
Project No: 72012(116)
File ref: KCOM

AMENDMENT RECORD

Amdt	Incorporated by	Date

Amdt	Incorporated by	Date

SUBJECT: FUEL SUPPLY HOSE – NSN 4720-99-977-7482

INTRODUCTION

1 Upon becoming unserviceable, the 4 metre length fuel supply hose is to be replaced with a new hose of 6 metre length.

1.1 Limitations on use of equipment. Nil.

APPLICABILITY

2 Cooking Outfit No 5, NSN 7360-99-132-2518.

2.1 Held by user units.

2.2 Unmodified stock, held at all levels of technical storage.

PRIORITY

3 ARMY: Routine - upon the present hose becoming unserviceable.

4 RAF: As per instructions issued by Cat Pol 2 (RAE).

IMPLEMENTATION

5 ARMY: This instruction is to be implemented by units authorized to carry out levels 2, 3 and maintenance.

6 RAF: Units, when the present hose becomes unserviceable.

7 Vehicle Depots before issue of the equipment.

DOCUMENTATION

8 All recipients of this instruction. Add particulars to AESP 7360-G-100-821 Gen Instr Index.

Stores, tools and equipment

9 The following item is to be demanded quoting this instruction as authority for demand, and stated data provided:

9.1 Registration/serial number of equipment held by user units.

9.2 Registration/serial number of equipment or scaling schedule/serial number of equipment for unmodified stock held at all levels of technical storage.

Item No	DMC	NSN/ Part No	Designation	Qty per eqpt
1	J2	J2 4720-99-470-7029	Hose Fuel Armoured 6 metre	1

Stores to be removed and reduced to scrap.

Item No	DMC	NSN/ Part No	Designation	Qty per eqpt
1	J2	J2 4720-99-977-7482	Hose Fuel Armoured 4 metre	1

Sequence of operations

NOTE

The item numbers of Para 8 are used as reference throughout this instruction.

10 Carry out the modification as follows:

10.1 No changes are necessary to fit the new hose, as it is a direct replacement for the original item.

Testing after embodiment

11 Check operation of the cookset, paying particular attention to signs of leaks.

EFFECT ON WEIGHT

12 Nil.

PUBLICATION AMENDMENTS

NOTE

Necessary amendments will be issued separately.

13 CES 40081 will require amendment.

COOKING OUTFIT, NO 5

GENERAL INSTRUCTION NO 3

Sponsor:
DGEME(A)

Publications Authority:
Vehicles and Weapons Branch REME
Project No: 72012(166)
File ref: KCO1

AMENDMENT RECORD

Amdt	Incorporated by	Date

Amdt	Incorporated by	Date

SUBJECT: INSECURE OVEN LINERS

INTRODUCTION

1 Cases have arisen where the oven liners have become detached from the oven outer case. This instruction lays down the procedure to re-secure the liner.

1.1 Limitations on use of equipment. Nil.

APPLICABILITY

2 Oven Assembly NSN 7360-99-139-1505

2.1 Held by user units.

2.2 Unmodified stock, held at all levels of technical storage.

PRIORITY

3 ARMY: Routine - upon detachment of the oven liner.

4 RAF: Routine - upon detachment of the oven liner.

ESTIMATED TIME REQUIRED

5 ARMY: This instruction is to be implemented by units authorized to carry out levels 2, 3 and 4 maintenance.

6 RAF: As per current servicing policy.

DOCUMENTATION

7 All recipients of this instruction: Add particulars to AESP 7360-G-100-821 Gen Instr Index.

Stores, tools and equipment

8 The following stores or suitable equivalents are to be obtained locally:

Item No	DMC	NSN/ Part No	Designation	Qty per eqpt
1	G1	5306-99-135-8632	Bolt M8 x 40 x 1.25 mm corrosion resistant steel	4
2	G1	5310-99-136-2753	Washer flat corrosion resistant steel	8
3	G1	5310-99-136-4877	Nut M8 x 1.25 x 6.5 4, corrosion resistant steel	4

NOTE

- (1) Under NO circumstances should cadmium plated items be utilised instead of items 1, 2 and 3.
- (2) Zinc plate is acceptable only where the listed items are unavailable.

Sequence of operations**NOTE**

The 'item numbers' of Para 8 are used as reference throughout this instruction.

9 Carry out this modification as follows:

- 9.1 Remove and discard the four retaining screws from the spacers.
- 9.2 File off the rivet area of the spacers, keeping the ends square.
- 9.3 Drill an 8 mm clearance hole through each spacer.
- 9.4 Reassemble the liner to the shell with the fixings (items 1, 2 and 3). Ensure that the bolt length is reduced to ensure minimum protrusion through the nut, and that the nut is fitted to the inside of the oven.

Testing after embodiment

10 Nil.

EFFECT ON WEIGHT

11 Negligible.

PUBLICATION AMENDMENTS**NOTE**

Necessary amendments will be issued separately.

12 Nil

COOKING OUTFIT, NO 5

GENERAL INSTRUCTION NO 4

Sponsor:
DGES(A)

Publications Authority:
Vehicles and Weapons Branch REME
Project No: 72112(237)
File ref: KCO1

AMENDMENT RECORD

Amdt	Incorporated by	Date

Amdt	Incorporated by	Date

SUBJECT: REPLACEMENT CONTROL VALVE PACKING

INTRODUCTION

1 The remote burner control valve packing, NSN J2 5330-99-125-1775 is obsolete. When the item is defective it is to be replaced with a Packing Preformed NSN J2 5330-99-251-9180.

APPLICABILITY

- 2 Cooking Outfit No. 5:
- 2.1 Held by user units.
 - 2.2 Unmodified stock, held at all levels of technical storage.

PRIORITY

3 ARMY: Routine - upon the packing becoming unserviceable.

IMPLEMENTATION PLAN

- 4 This instruction is to be implemented by:
- 4.1 ARMY - This instruction is to be implemented by units authorized to carry out levels 1, 2, 3 and 4 maintenance.

DOCUMENTATION

5 All recipients of this instruction. Add particulars to AESP 7360-G-100-821 Gen Instr Index.

Stores, tools and equipment

6 The following item is to be demanded quoting this instruction as authority.

Item No	DMC	NSN/ Part No	Designation	Qty per eqpt
1	J2	5330-99251-9180	Packing Preformed (Remote Burner Control Valve).	1

7 The following item is to be discarded.

Item No	DMC	NSN/ Part No	Designation	Qty per eqpt
1	J2	5330-99251-9180	Packing, asbestos, rd, (twisted strand type).	1

Sequence of operations

8 Carry out this General Instruction as follows:

NOTE

The item number of Para 6 is used as reference throughout this instruction.

8.1 When overhauling the remote burner control valve, remove the Packing, asbestos rd. (twisted strand type) (item 2). Discard the packing in accordance with current legislation on asbestos disposal.

8.2 Upon assembly of the control valve, fit the Packing Preformed (item 1), in the position of Fig 1 item 4.

Testing after embodiment

9 Ensure that the control valve is free to operate, without fuel leaks.

EFFECT ON WEIGHT

10 Nil.

PUBLICATION AMENDMENTS

11 AESP 7360-G-100-711 requires amendment.

NOTE

Necessary amendment will be issued separately.

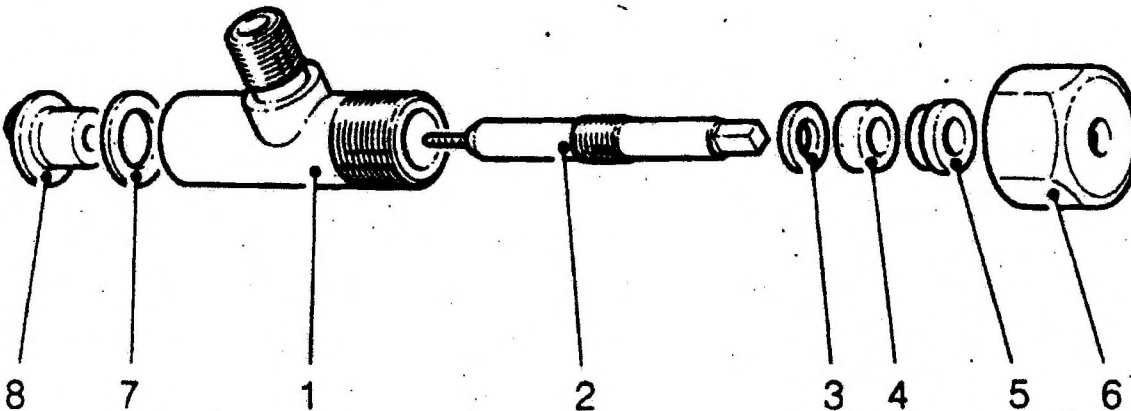

Fig 1 Exploded view of control valve

COMMENT(S) ON AESP*

To: ECI PT
MoD, Abbey Wood
Bristol
B34 8JH

From:
.....
.....

Senders Reference	BIN Number	Date
AESP* Title:		
Chapter(s)/Instruction	Page(s)/Paragraph(s)	
If you require more space please use the reverse of this form or a separate piece of paper. Comment(s): 		

Signed: Telephone No:
 Name (Capitals): Rank/Grade: Date:
 X

FOR AESP* SPONSOR USE ONLY

To: From:

Thank you for commenting on AESP*
 Your reference: Date:

Action is being taken to:	Tick	Tick
Issue a revised/amended AESP*	<input type="checkbox"/>	Under investigation
Incorporate comment(s) in future amendments	<input type="checkbox"/>	No action required
Remarks		

Signed: Telephone No:
 Name (Capitals): Rank/Grade: Date:

* AESP or EMER

