



Ministry
of Defence

Defence Equipment and Support
Secretariat
#2043 Maple 0a
Ministry of Defence
Abbey Wood
Bristol BS34 8JH



Email: DES SEC-PolSec LE-JSC-WPNS@mod.uk

[REDACTED]

[REDACTED]

Our Reference:
FOI2020/09247
Date:
14 September 2020

Dear Sir

Thank you for your email of 15 August 2020, requesting the following information:

***"I would like to make a freedom of information request for the AESP
2320-D-128-421"***

Your request has been handled in accordance with the Freedom of Information (FOI) Act 2000.

A search has been carried out of Ministry of Defence (MOD) records and it is confirmed that information is held within the scope of your request. A copy is enclosed of Army Equipment Support Publication (AESP) 2320-D-128-421: TRUCK UTILITY LIGHT (TUL) HS, TRUCK UTILITY MEDIUM (TUM) HS AND (TUM) BATTLEFIELD AMBULANCE HS, ALL VARIANTS.

It has proved necessary to withhold some information under qualified exemptions Section 26(1)(a) and (b) (Defence) and Section 38(1)(a) and (b) (Health and Safety) of the FOI Act. Section 26 applies to information that if disclosed would or would likely prejudice the defence of the British Islands or any colony; and/or the capability, effectiveness or security of the Armed Forces of the Crown or any forces cooperating with them. Section 38 applies to information that if disclosed would or would likely endanger the physical or mental health, or safety of any individual.

As both exemptions are qualified, it was necessary to undertake a Public Interest Test to determine whether the balance for withholding the information outweighs that for disclosure. General arguments in favour of release were that: full disclosure would demonstrate the MOD's commitment to openness and transparency; make the UK Government more accountable to the electorate; and the FOI Act contains a presumption for release. However, full disclosure would also help determine the location of vital classified communications equipment installed on the vehicles covered by this AESP, which if stolen or sabotaged would likely endanger the lives of Armed Forces personnel and disrupt or limit military operations and capabilities. On balance, it was determined that the information should be withheld. The level of prejudice against release of this exempted information has been set at the higher level of "would" rather than "would be likely to".

If you have any queries regarding the content of this letter, please contact this office in the first instance. If you wish to complain about the handling of your request, or the content of this response, you can request an independent internal review by contacting the Information Rights Compliance team, Ground Floor, MOD Main Building, Whitehall, SW1A 2HB (e-mail CIO-FOI-IR@mod.gov.uk). Please note that any request for an internal review should be made within 40 working days of the date of this response.

Defence Equipment & Support

If you remain dissatisfied following an internal review, you may raise your complaint directly to the Information Commissioner under the provisions of Section 50 of the Freedom of Information Act. Please note that the Information Commissioner will not normally investigate your case until the MOD internal review process has been completed. The Information Commissioner can be contacted at: Information Commissioner's Office, Wycliffe House, Water Lane, Wilmslow, Cheshire, SK9 5AF. Further details of the role and powers of the Information Commissioner can be found on the Commissioner's website at <https://ico.org.uk/>.

Yours sincerely

DE&S Secretariat



Ministry of Defence

Army Equipment Support Publication

TRUCK UTILITY LIGHT (TUL) HS, TRUCK UTILITY MEDIUM (TUM) HS AND (TUM) BATTLEFIELD AMBULANCE HS, ALL VARIANTS

This publication contains information covering the
requirement of Category 421 at levels 1 - 4.

2320-D-128-421

3rd Edition May 2017

Superseding 2nd Edition March 2011

**Sponsored for use in the
United Kingdom Ministry of Defence
and Armed Forces by: DES LE VST**

~~This information is released by the UK Government for Defence purposes only. This information must be afforded the same degree of protection as that afforded to information of an equivalent classification originated by the recipient Government or as required by the recipient Government's National Security regulations. This information may be disclosed only within the Defence Department of the recipient Government, except as otherwise authorized by the Ministry of Defence (Army). This information may be subject to privately owned rights.~~

Publication Authority: DES LE VST

Conventional vehicle solutions
Mail Point#3157
Cedar 1
Mod, Abbey Wood
Bristol, BS34 8JH

Service users should send their comments through the channel prescribed for the purpose by the publication sponsor.

© CROWN COPYRIGHT RESERVED

~~THIS DOCUMENT IS THE PROPERTY OF HER BRITANNIC MAJESTY'S GOVERNMENT, and is issued for the information of such persons only as need to know its contents in the course of their official duties. Any person finding this document should hand it in to a British forces unit or to a police station for its safe return to the Ministry of Defence, (DDef-Sy), Main Building, Whitehall London, SW1A 2HB, with particulars of how and where found. THE UNAUTHORIZED RETENTION OR DESTRUCTION OF THIS DOCUMENT IS AN OFFENCE UNDER THE OFFICIAL SECRETS ACTS OF 1911-1989. (When released to persons outside Government service, this document is issued on a personal basis. The recipient to whom it is entrusted in confidence, within the provisions of the Official Secrets Acts 1911-1989, is personally responsible for its safe custody and for seeing that its contents are disclosed only to authorised persons).~~

AMENDMENT RECORD

Amdt No.	Incorporated By (Signature)	Date
1	Incorporated	May 18
2	Incorporated	Apr 19
3	Incorporated	Nov 19
4		
5		
6		
7		
8		
9		
10		
11		
12		
13		
14		
15		
16		
17		
18		
19		
20		
21		
22		
23		
24		
25		
26		
27		
28		
29		
30		
31		

Amdt No.	Incorporated By (Signature)	Date
32		
33		
34		
35		
36		
37		
38		
39		
40		
41		
42		
43		
44		
45		
46		
47		
48		
49		
50		
51		
52		
53		
54		
55		
56		
57		
58		
59		
60		
61		
62		

CONTENTS

PRELIMINARY MATERIAL	Page
Front cover (title page)	(i)
AMENDMENT RECORD	(iii)/(iv)
CONTENTS (this list)	(v)
PREFACE	(v)
Introduction	(v)
Publication authority	(vi)
PREPARATION FOR SPECIAL ENVIRONMENT INSTRUCTION INDEX	(vii)/(viii)

PREFACE

Sponsor: OSP-OSVP
Project Number: -
File Ref: -
Publication Authority: DES LE OSP-OSVP-CVS

INTRODUCTION

- 1 The Publication Sponsor is responsible for the allocation of instruction numbers.
- 2 All Preparation for Special Environment instructions as issued are to be recorded in manuscript by the recipient on the Numerical Instruction Index provided. Amendments to individual instructions are to be recorded on the instruction amendment record. All extant instructions and amendments can be found listed in the main AESP index.

NOTE

- The Publication Sponsor is responsible for the preparation and maintenance of the Special Environment Instruction Index and will advise the Distribution Authority on the issue of completed and subsequent blank index pages necessary.
- 3 The Publication Sponsor is responsible for the preparation and maintenance of the Instruction Index and will advise the Distribution Authority on the issue of completed and subsequent blank index pages necessary.
 - 4 Army Equipment Support Publications (AESP) are issued under Defence Information Notices (DIN) authority and where AESPs specify action to be taken, the AESP will of itself be sufficient authority for such action and also for the demanding of the necessary stores.
 - 5 This edition is a new common AESP for the Truck Utility Light (TUL) HS, Truck Utility Medium (TUM) HS and TUM Battlefield Ambulance HS, All Variants. It is produced under the prime AESP Octad number 2320-D-128-Octad.
 - 6 All subsequent Preparation for Special Environment Instructions will be contained in this Octad and will be applicable to the TUL HS, TUM HS and TUM Battlefield Ambulance, All variants unless specified within the instruction.
 - 7 Users should forward any comments on this publication in accordance with Army Equipment Support Publication (AESP) 0100-P-011-013. All comments are only to be submitted using the electronic and interactive Form 10 which can be accessed and downloaded from the Joint Asset Management and Engineering Solutions (JAMES) Portal (via Hot Topic – Forms) or from DR TDOL (F10).
 - 8 All electronic Form 10s are to be completed and forwarded to the Form 10 cell using the instructions accompanying the form in its template location. Security procedures are to be observed in accordance with Joint Services Publication (JSP) 440.

9 The Form 10 procedure is only to be used for the purpose of commenting on the content of an individual AESP and must not be used:

9.1 In place of the Equipment Failure Reporting (EFR) procedure outlined in The Land Equipment Unit Maintenance Standards (LEUMS).

9.2 For subjects which are the concern of the Technical Staff Suggestions outlined in Army General and Administrative Instructions (AGAI):

Publication authority

10 The publication authority for this AESP is as follows:

Operational Support Vehicles Programme (OSVP)
Mail Point #1309
Spruce 3c
DE&S, Abbey Wood
Bristol, BS34 8JH
DESLEOSP-OSVP-CVS-Sp@mod.uk

PREPARATION FOR SPECIAL ENVIRONMENT INSTRUCTION INDEX

11 The index is to be kept up to date by the User entering Preparation for Special Environment Instructions as and when they are published.

Instr No. (1)	Subject (2)
1	Waterproofing Instructions GS variants
2	Waterproofing Instructions FFR variants
3	Waterproofing Instructions BFA variants
4	Improved Air Filtration System for Desert Environment, TUL and TUM
5	CANCELLED
6	
7	
8	
9	
10	
11	
12	

**TRUCK UTILITY LIGHT (TUL) HS GS (WATERPROOFED VARIANTS ONLY) TRUCK UTILITY
MEDIUM (TUM) HS GS (WATERPROOFED VARIANTS ONLY)**

CODE NB 4219 3100 CODE NB 5008 3100 CODE NB5009 3100

PREPARATION FOR SPECIAL ENVIRONMENT INSTRUCTION NO. 1

WATERPROOFING INSTRUCTIONS GS VARIANTS

(Completely Revised)

Sponsor: OSVP PT
Project number:
File ref: SUV/8/25/1B
Publication agency: OSVP PT, DE&S Abbey Wood

AMENDMENT RECORD

Amdt No.	Incorporated By (Signature)	Date
1	Incorporated	May 18
2		
3		

Amdt No.	Incorporated By (Signature)	Date
4		
5		
6		

SUBJECT: Waterproofing instructions Stage 'B' for GS variants

CONTENTS

Para

- 1 Introduction (WARNINGS) (CAUTIONS)
- 3 Waterproofing stage 'B'
- 4 De-waterproofing stage 'C'
- 5 De-waterproofing stage 'D'
- 7 Stores required
- 11 Stores, tools and equipment (WARNING)
- 12 General Instructions
- 18 Materials, Uses and Application (WARNING)
- 27 Waterproofing Arrangements
- 28 Checking the Waterproofing Kit
- 29 Waterproofing of Cargo
- 31 Preparatory servicing (CAUTIONS)
- 32 Deleted
- 35 Waterproofed equipment markings
- 36 Component Location
- WATERPROOFING STAGE 'B' (CAUTION)
- 37 Sequence of operations
- 38 Task 1 Vehicle batteries (WARNINGS)
- 39 Task 2 Engine air cleaner (CAUTION)
- 40 Task 3 Alternator (CAUTION)
- 41 Task 4 Clutch fluid reservoir

(continued)

CONTENTS (continued)

Para

- 42 Task 5 Brake fluid reservoir (WARNING) (CAUTION)
- 43 Task 6 Heater plugs
- 44 Task 7 Windscreen washer reservoir (WARNING) (CAUTION)
- 45 Task 8 Fuel tank breather
- 46 Task 9 Webasto heater
- 47 Task 10 Heater
- 48 Task 11 Steering column switches
- 49 Task 12 Deleted
- 50 Task 13 Inter-vehicle start socket
- 51 Task 14 Front wiper motor box
- 52 Task 15 Front seat belts
- 53 Task 16 Rear seat belts
- 54 Task 17 Rear wiper motor box – hard top vehicle only
- 55 Task 18 Flywheel housing
- 56 Task 19 Number plate lamp
- 57 Task 20 NATO 12 pin towing socket
- 58 Task 21 Centre console (CAUTIONS)
- 59 Task 22 Batteries (2) (WARNINGS)
- 60 Task 23 Bowman HF radio and Personal User Data Terminal (PUdT)
- 61 Task 24 Direct Current charging unit (DCCU)
- 62 Task 25 Radio selector box (RSB)
- 63 Task 26 Radio batteries and stillage trays
- 64 Task 27 Escape hatch – soft top vehicle (WARNING)
- 65 Task 28 Escape hatch – hard top vehicle (WARNING)
- 66 Task 29 Preservation
- 67 Task 30 Tailgate – soft top vehicle
- 68 Task 31 Rear door hard top vehicle
- 69 Task 32 Towrope
- 70 Task 33 Fire extinguisher and items of equipment
- 71 Task 34 Stage 'B' kit and removed items
- 72 Task 35 Waterproofed equipment marking stage 'B'
- 73 Task 36 Waterproofing the AESP
- 74 Task 37 Driving instructions for prepared fording (CAUTIONS)
DE-WATERPROOFING STAGE 'C' (CAUTIONS)
- 75 Task 38 Engine oil level check (WARNINGS) (CAUTION)
- 76 Task 39 Centre console
- 77 Task 40 Alternator reconnection
- 78 Task 41 Vehicle batteries (2) (WARNINGS)
- 79 Task 42 Bowman radio installation
- 80 Task 43 Fuel tank breather
- 81 Task 44 Brake fluid reservoir
- 82 Task 45 Clutch fluid reservoir
- 83 Task 46 Heater motor
- 84 Task 47 Flywheel housing
- 85 Task 48 Front seat belts (WARNING)
- 86 Task 49 Front seats
- 87 Task 50 Rear door – hard top vehicle
- 88 Task 51 Tailgate – soft top vehicle
- 89 Task 52 Rear seat belts (WARNING)
- 90 Task 53 Steering column box
- 91 Task 54 Front wiper box
- 92 Task 55 Rear wiper box - hard top vehicle
- 93 Task 56 Heater plugs
- 94 Task 57 Towrope
- 95 Task 58 Escape hatch – hard top vehicle
- 96 Task 59 Escape hatch – soft top vehicle
- 97 Task 60 Fire extinguisher

(continued)

CONTENTS (continued)

Para

98	Task 61 Number plate lamp
99	Task 62 Waterproofed equipment marking stage 'C'
100	Task 63 Temporary halt procedure WET SHOD RE-EMBARKATION (WARNING)
101	Summary DE-WATERPROOFING STAGE 'D' (CAUTIONS)
102	Task 64 Oil contamination check (WARNINGS) (CAUTION)
103	Task 65 Clutch and brakes
104	Task 66 Wash down (WARNING) (CAUTION)
105	Task 67 Alternator breather (WARNING)
106	Task 68 Webasto heater
107	Task 69 Heater control cables
108	Task 70 Front seats (WARNING)
109	Task 71 Door locks and hinges
110	Task 72 Hubs and brakes (WARNINGS)
111	Task 73 Clutch
112	Task 74 Stowage compartments (WARNING)
113	Task 75 Vehicle battery compartment(WARNINGS)
114	Task 76 Floor coverings (WARNING)
115	Task 77 NATO 12 pin towing socket
116	Task 78 Deleted
117	Task 79 Component breather system drain
118	Task 80 Rear view mirrors – door mounted
119	Task 81 Front and rear lights
120	Task 82 Gear lever housing
121	Task 83 Transfer gearbox selector housing
122	Task 84 Propeller shafts
123	Task 85 Lubrication and maintenance
124	Task 86 Engine controls
125	Task 87 Rear tow pintle
126	Task 88 Front seat belts (WARNING)
127	Task 89 Future waterproofing requirements

Table

Page

1	Man Hour Content	6
2	Waterproofing task check list Truck Utility Light (HS) GS and Truck Utility Medium (HS) GS	57

Fig

Page

1	Deleted	12
2	Waterproofed equipment markings	13
3	Component layout	14
4	Air cleaner	16
5	Alternator disconnection	17
6	Alternator breather hose	18
7	Clutch fluid reservoir	19
8	Brake fluid level sensor	20
9	Brake fluid reservoir	20
10	Heater plugs	21
11	Fuel tank breather	22
12	Webasto heater	23
13	Webasto caps	24

(continued)

CONTENTS (continued)

Fig		Page
14	Webasto switch	24
15	Heater multi-plugs	25
16	Motor drain	25
17	Steering column switches.....	26
18	Deleted	26
19	Inter-vehicle start socket	27
20	Front wiper box.....	27
21	Rear wiper box	28
22	Flywheel housing.....	29
23	Number plate lamp	29
24	Towing socket terminals.....	30
25	Console cover	31
26	Centre console	32
27	Console drain	33
28	Map lamp.....	33
29	Batteries	34
30	Mounting tray.....	35
31	DCCU	36
32	RSB Connections	37
33	Radio batteries and Stillage trays	38
34	Soft top hood	39
35	Escape hatch soft top	40
36	Tailgate.....	41
37	Rear door stay.....	42
38	Rear door	42

INTRODUCTION

WARNINGS

- (1) **FORDING AREA. BEFORE FORDING OPERATIONS COMMENCE A FULL CHECK AND RECONNAISSANCE MUST BE CARRIED OUT TO ENSURE THE AREA IS SAFE AND FREE OF OBSTACLES AND DEEP POT HOLES. FORDING IN UNSAFE CONDITIONS COULD RESULT IN INJURY OR DEATH.**
- (2) **PERSONNEL SAFETY. AFTER FORDING, ALL SEAT BELTS MUST BE RE-FITTED AT DE-WATERPROOFING STAGE 'C' TO MEET ROAD TRAFFIC REGULATIONS.**

CAUTIONS

- (1) **EQUIPMENT DAMAGE. Only waterproofed variants with the Equipment Asset Code (EAC) listed on page 1 are to be implemented with this instruction. The vehicle must not be subjected to Prepared Fording until the stage 'B' kit is fitted as instructed in this AESP.**
- (2) **VEHICLE RECORD BOOK. This instruction AESP 2320-D-128-421 must be retained with the vehicle record book.**

1 This instruction details the method of waterproofing to enable the vehicle to be capable of Prepared Fording through an effective depth of 1.5 metres including ramp angle, wheel sink and wave height. The waterproofing when applied will enable the vehicle to ford with the minimum of preparation for six minutes. To enable the vehicle to achieve this objective, a Special Environment Waterproofing kit is fitted.

2 Where variations from standard occur on the vehicle or equipment due to modifications or contract changes, advice and direction of the unit Motor Transport Officer (MTO) should be sought regarding additional or amended tasks.

Waterproofing stage 'B'

3 The modification kit NSN 7XDW 2540-99-573-6345 is fitted prior to Prepared Fording. The maximum time allowed to complete this stage is two hours. This will permit the vehicle to disembark or embark wet-shod dependent upon operational requirements. On completion of this stage pre-ford running time should be restricted to 15 minutes. Post ford mileage must conform to stages 'C' and 'D'.

De-waterproofing stage 'C'

4 The tasks in this stage can be completed in a few minutes and must be conducted within 15 minutes of leaving the water. The seat belts must be re-fitted at de-waterproofing stage 'C' to meet road traffic regulations.

De-waterproofing stage 'D'

5 Tasks in this stage are dependent on operational conditions. Certain tasks may need to be carried out within 25 miles (40 Km) or 12 hrs from the point of disembarkation. The remaining tasks should be carried out as soon as conditions permit but within 250 miles (400 Km) or 3 days of landing.

NOTE

- (1) Vehicle mechanic assistance will be required for Tasks 2, 3, 9, 15, 48, 66, 67, 68, 69, 70, 71, 72, 75, 79, 82, 83, 85, 86, 87 and 88.

Associated publications

- 6 Refer to Army Equipment Support Publication (AESP):
- 6.1 2320-D-128-201 Operating Information
 - 6.2 2320-D-128-522 Maintenance Instructions
 - 6.3 2320-D-128-523 Repair Instructions
 - 6.4 2320-D-128-601 Maintenance Schedules
 - 6.5 2300-A-600-013 Waterproofing Regulations Vehicles and Equipment

STORES REQUIRED

7 Items for waterproofing kits are MOD controlled stores. Operationally they are issued without demand. Should issue be authorized for training purposes:

7.1 In the UK they are to be demanded from the Defence Storage and Distribution Agency (DSDA), Bicester, through district headquarters.

7.2 Overseas, they are to be demanded through formation or district headquarters.

8 When a complete stage 'B' kit is required, the full Army designation of the vehicle or equipment, including code number and contract number is to be stated on the demand. Authority for issue must be quoted.

9 Normally, individual items are not issued separately but may be demanded to make good kit deficiencies. Such demands are to quote full part numbers and designations as shown in this waterproofing instruction Para 11.1. A brief explanation of circumstances necessitating the demand is to be attached.

10 Inflammable items which have a shelf storage life are listed at Para 11.2 of the kit list. These items are to be demanded separately by units prior to undertaking the fitting of waterproofing kits.

TABLE 1 MAN HOUR CONTENT

Serial (1)	Detail (2)	Approximate time in man- hours		Maximum No. of men who can be usefully employed (5)	Maximum time required in hours (6)
		Crew Dvr (3)	Veh Mech (4)		
1	Perusal of this AESP and checking of the Waterproofing kit against the kit list.	2	-	2	1
2	Servicing of equipment.	5	1	2	5
3	Waterproofing Stage 'B'.	1.25	0.3	2	1.25
4	De-waterproofing Stage 'C'.	0.4	0.2	3	0.2
5	Wet shod re-embarkation.	0.5	0.3	3	0.5
6	De-waterproofing Stage 'D'.	5	7	2	12

Stores, tools and equipment

WARNING

HEALTH AND SAFETY. MATERIALS USED IN WATERPROOFING ARE REQUIRED TO MEET OBLIGATIONS INTRODUCED UNDER THE CONTROL OF SUBSTANCES HAZARDOUS TO HEALTH REGULATIONS 2004 (COSHH). SAFETY INFORMATION RELATING TO MATERIALS USED IS CONTAINED IN JSP (F) 395-CATALOGUE OF HAZARDOUS STORES.

11 The following stores are to be demanded:

11.1 The following modification items are to be demanded quoting this instruction as authority for demand.

Item No (1)	DMC (2)	NSN/Part No (3)	Designation (3)	Qty per veh (4)
	7XDW	2540-99-573-6345	Special environment waterproofing kit (WPG9734B) Truck Utility Light (HS) GS and Truck Utility Medium (HS) GS (STC 4442) consisting :-	1
1	AESP	2320-D-128-421	Waterproofing instruction No. 1 (VDX 100850)	(1)
2	7XDW	5340-99-573-6317	Cover, centre console (IPK 100020)	(1)
3	7XDW	5340-99-928-8246	Strap-console cover (IPM100080)	(1)
4	7XDW	2530-99-573-6323	Cover, brake fluid reservoir (IPK 100090)	(2)*
5	7XDW	2520-99-573-6326	Cover, clutch fluid reservoir (IPK 100120)	(3)*
6	7XDW	2530-99-573-6442	Cover, steering column box (QRS 100010)	(4)*
7	7XDW	5340-99-573-6328	Cap, Webasto intake (IPK 100140)	(2)*
8	7XDW	5340-99-573-6327	Cap, Webasto exhaust (IPK 100130)	(2)*
9	6MT1	4730-99-533-2966	Clamp, Webasto (CN100508L)	(1)
10	7XDW	6240-99-573-6467	Cover, map lamp (XDL 100030)	(1)
11	7XDW	5410-99-573-6531	Stay, tailgate (BHF 710010)	(2)
12	7DXW	5410-99-573-6530	Stay, rear door (BHF 710029)	(1)
13	7XDW	5340-99-573-6445	Cap, protective (RRC 5110)	(6)*
14	7XDW	5325-99-573-6334	Blanking plug, brake harness (IPS100010)	(1)
15			Deleted	
16	7XRU	5365-99-732-7008	Plug, flywheel housing (ERC 7295)	(1)
17	7XDW	5340-99-655-4665	Plug silicone bonding (IPS 100040)	(4)*
18	7XDW	6220-99-845-0035	Cover, number plate lamp (XFK100310)	(2)*
19	7XDW	4020-99-661-3612	Cord Elastic	(1)
20	7XDW	2540-99-937-6287	Seat cover, squab (HBA 106790)	(2)
21	7XDW	2540-99-572-5723	Seat cover, cushion (HCA 106410)	(2)
22	7XDW	2540-99-573-6335	Bag, stage 'B' kit (IPT 100010)	(1)
23	7XDW	2540-99-573-6336	Bag, zipped stowage (IPT 100050)	(4)
24	H10	7930-99-244-6936	Container, spray (IRE 100000)	(1)
25	6WPG	2540-99-816-2670	Bag, PVC 36 in. x 24 in. (WPG 8220)	(2)
26	6WPG	5970-99-664-8764	Tape, adhesive PVC Scotch 88 (IYN 100000)	(1 roll)
27	H4	8105-99-135-6190	Bag, plastic 450 mm x 255 mm (IPT 1000800)	(2)
28	F1	8020-99-943-0417	Brush, artist's flat fitch No.2 (IRX 100000)	(1)

(continued)

Item No (1)	DMC (2)	NSN/Part No (3)	Designation (4)	Qty per veh (5)
29	F1	8020-99-125-5009	Brush 1 in. wide (IRX 100010)	(1)
30	H21	4020-99-942-5038	Rope, fibrous (IRY 100000)	(10 m)
31	Y2	5340-99-933-3089	Cable tie	(10)*

11.2 Stores or suitable equipment to be obtained locally:

Item No (1)	DMC (2)	NSN/Part No (3)	Designation (4)	Qty per veh (5)
32			Deleted	
33	6WPG	5970-99-225-1703	Compound, silicone 100 g tube	1
34	6WPG	8030-99-062-9759	PX-24 water displacing fluid	1 litre
35	POL	9150-99-224-8885	Grease XG-286, 3 kg tin	150 g
36	POL	9150-99-943-2033	Grease PX-7, 100 g tube	1
37	H1	6850-99-356-7379	Lec Klene solvent cleaner 300 ml	1
38	POL	6850-99-224-5036	AL-11 windscreen washer fluid	A/R
39	7XDW	2540-99-627-6986	Seat belt fixing kit (STC 4445)	1 kt
40		8030-01-475-2444	Loctite 243 Thread Lock	A/R

11.3 Special tools to be obtained locally:

Item No (1)	DMC (2)	NSN/Part No (3)	Designation (4)	Qty per veh (5)
41	F1	5120-99-812-0439	Torque wrench, 1/2 in. square drive	1

NOTES

- (1) The item numbers of Para 11 are used as reference throughout this instruction.
- (2) (). Denotes item quantities are supplied as part of the overall Special environment waterproofing kit.
- (3) * Denotes a spare is provided to cater for defective or damaged goods.
- (4) Item number of Para 11.3 is required for Vehicle Mechanic (VM) assistance tasks.

GENERAL INSTRUCTIONS

12 The instructions in this publication describe the action to be taken before and after fording, to protect the equipment against damage resulting from immersion in sea water.

13 Waterproofing is carried out in stages and each stage is to be completed in the sequence given in this instruction. The tasks within each stage are shown in the most suitable sequence, but this may be varied according to circumstances. Where complete task coverage requires more than one page, the task should be read in its entirety before commencing a page by page progression.

14 **CLEANLINESS IS THE FIRST ESSENTIAL OF SUCCESSFUL SEALING.** When applying compounds, ensure that the hands are clean and free from grease and that all surfaces to which sealing compounds are to be applied are scrupulously clean. Mud, oil, grease or water will spoil adhesion.

15 **REMEMBER THAT ALL WATERPROOFING MUST BE 100 % SUCCESSFUL.** One carelessly treated component may cause failure at a critical moment, so take great care with every detail. Whenever waterproofing is being carried out during wet weather, suitable shelter should be arranged over the vehicle.

16 The vehicle load must be made secure to prevent any movement whilst the vehicle is ascending or descending the ramp on the Assault Ship or Landing Craft.

17 If difficulties are encountered, the Unit MTO should be consulted.

MATERIALS, USES AND APPLICATION

WARNING

HEALTH AND SAFETY. MATERIALS USED IN WATERPROOFING ARE REQUIRED TO MEET OBLIGATIONS INTRODUCED UNDER THE CONTROL OF SUBSTANCES HAZARDOUS TO HEALTH REGULATIONS 2004 (COSHH). SAFETY INFORMATION RELATING TO MATERIALS USED IS CONTAINED IN JSP (F) 395-CATALOGUE OF HAZARDOUS STORES.

18 Lec Klene solvent cleaner: Used for cleaning and degreasing surfaces before applying any of the various waterproofing materials. Lec Klene is a flammable liquid therefore suitable safety precautions should be taken.

19 Prestik P5408: A plastic sealing compound which, when moulded to joints and apertures prevents water entry. It is also used in some cases to cover electrical components and connections to prevent failure of the electrical system.

19.1 Prestik P5408 is supplied as a strip 24 in. (600 mm) x 1-1/2 in. (40 mm) wide, in a protective wrapping.

19.2 The application of Prestik P5408 is shown in Fig 1. It must not be removed from its wrapping until actually required for application. When handling, the hands must be clean and free from grease. Remove the backing strip as shown in Fig 1. Where a considerable length is called for in a particular task, it is better to apply a series of short lengths, overlapping the strips as shown in Fig 1, and moulding the top layer to the under layer. This allows ease of handling and avoids excessive stretch. It is important that strips of the correct length are used as detailed in this instruction.

NOTE

Always keep Prestik P5408 clean and dry. The biggest hindrances to successful waterproofing are oil, dirt, and water therefore all surfaces to be waterproofed must be perfectly clean and dry. The fingers may, however, be slightly moist to prevent the Prestik P5408 sticking to them.

20 Cover, elastic, waterproofing: Manufactured from rubber and used to enclose various components. Before use, examine carefully and repair tears, splits or pin holes with adhesive tape. A spare cover of each type required to waterproof the equipment is provided in the kit.

21 Grease sea water resisting XG-286: Is used for the protection against salt water corrosion on components. The surface should be thoroughly covered with an even, unbroken film of grease. A lumpy coating is wasteful and provides no better protection.

22 Silicone compound XG-250: Supplied in 100 g tubes and 400 g aerosol containers for junction boxes, fuse holders and other electrical components which must remain operative at all times. The components should be covered with a generous, unbroken, even film of silicone compound.

23 Grease PX-7: Supplied in 100 g tubes it is used for the preservation of battery terminals and other electrical terminals.

24 Fluid, water displacing, PX-24: Supplied in 1 litre containers. It is used for corrosion prevention and to wash salt water from components as detailed in this instruction.

25 Bag, envelope Polyvinyl Chloride (PVC):

25.1 These bags are manufactured in varying sizes from a waterproof material, which are used to enclose parts of the vehicle as detailed in this instruction and other items as may be desired.

25.2 Before use, the bag must be inspected for pin holes, tears or split seams, which can be repaired with suitable lengths of adhesive tape or Prestik P5408.

26 Scotch super 88 electrical insulation tape: A waterproof adhesive tape, suitable for repairing and sealing PVC bags, breathers, apertures, joints and components. The width of the tape can be increased by overlapping to the required width.

WATERPROOFING ARRANGEMENTS

27 The operations are to be carried out by Unit personnel unless otherwise stated. **THE WORK IS TO BE PLANNED AND CONTROLLED BY AN OFFICER WHO MUST ARRANGE FOR STAFF, TRAINED IN WATERPROOFING, TO INSPECT ALL TASKS PROGRESSIVELY AND TO ENSURE THAT THEY ARE COMPLETED SUCCESSFULLY.** A check list to assist operators will be found at the end of this instruction, it should be photocopied and used to check completion of each task. This list must be initialled by the operator as each task is passed as satisfactory.

CHECKING THE WATERPROOFING KIT

28 Before commencing waterproofing the vehicle, the kit must be checked against the kit list provided.

WATERPROOFING OF CARGO

29 Should it be desired to waterproof items of stores and equipment carried as cargo for which a waterproofing kit or specified suitable container is not available, use may be made of the range of BAGS, WATERPROOFING detailed below and available from Royal Logistics Corps (RLC) sources:

30 The following two PVC bags are reusable types fitted with zip closures, and primarily for use with the Trailer, Lightweight GS Cargo:

30.1 2540-99-815-9470, Bag cargo (WPG 9031). 1.8 m (72 in.) x 0.9 m (36 in.) x 0.45 m (18 in.).

30.2 2540-99-815-9471, Bag cargo (WPG 9032). 0.9 m (36 in.) x 0.9 m (36 in.) x 0.45 m (18 in.).

PREPARATORY SERVICING

CAUTIONS

(1) **EQUIPMENT DAMAGE.** A thorough examination of build standard waterproofing must be carried out by fully trained/competent personnel. It is essential that any faults found are rectified prior to the commencement of stage 'B' waterproofing.

(2) **VEHICLE PREPARATION.** Waterproofing demands maximum efficiency of vehicle performance. Ensure that your vehicle is 100 % fit for the task.

31 Examine build standard waterproofing with reference to Maintenance Schedule AESP 2320-D-128-601, Table 5, Maintenance Interval 3 months or 3000 miles (5000 km). Rectify any faults found.

31.1 Carry out 6000 miles (10000 km) servicing in accordance with AESP 2320-D-128-601, Table 7 to ensure full serviceability for fording. Do not change the engine oil or oil filter unless the vehicle is within 1000 miles (1666 km) of its next scheduled service.

31.2 Fill the vehicle fuel tank to capacity.

Deleted

NOTE

Deleted.

32 Deleted.

33 Deleted.

34 Deleted.

NOTE

Deleted.

| Fig 1 Deleted |

Waterproofed equipment markings

35 Ensure equipment markings are displayed correctly.

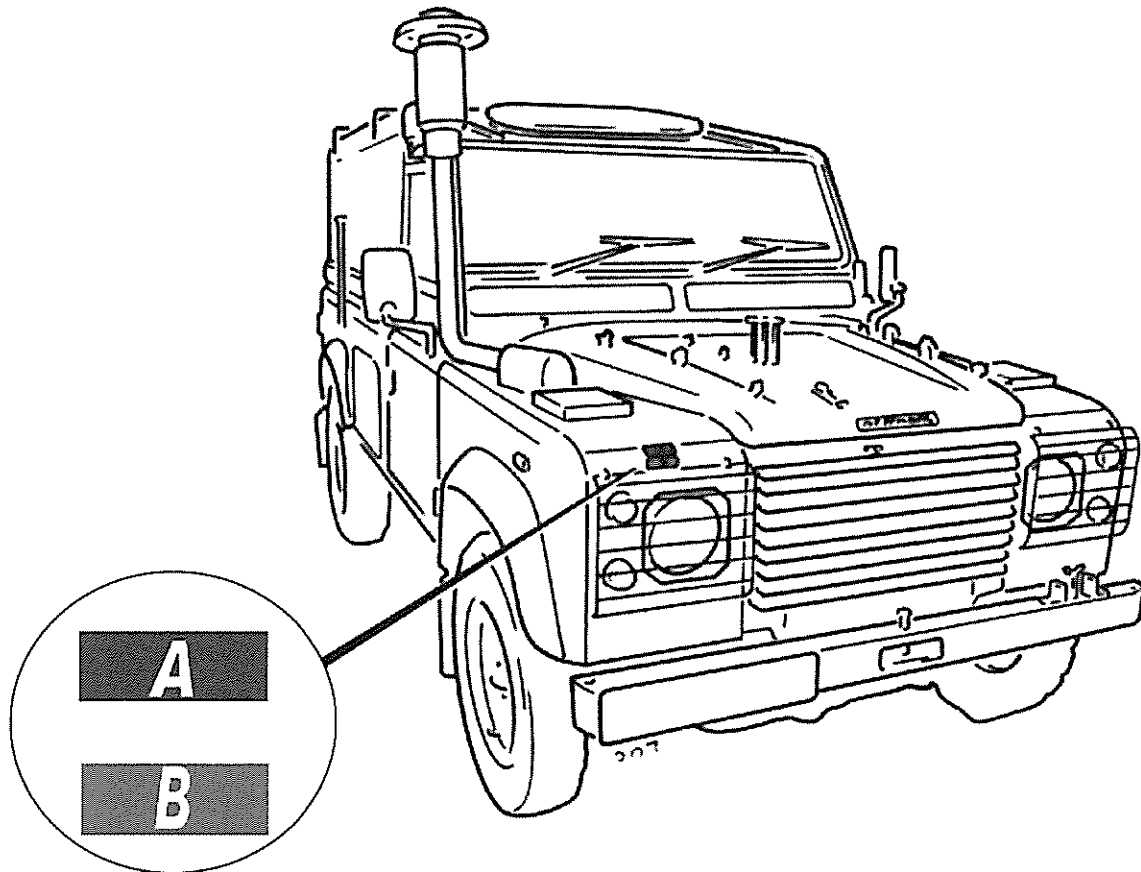



Colour meaning		Action
 Blue with white 'A' in centre	<u>SEMI-PERMANENT</u> Stage 'A' completed (build standard modifications)	Production build standard
 Red with white 'B' in centre	<u>SEMI-PERMANENT</u> Stage 'A' checked Stage 'B' completed Equipment passed for disembarkation	Assembly area, onboard Landing Ship or embarkation area
NOTE The stage 'B' marking must be covered with black adhesive tape when stage 'C' or 'D' has been completed. The marking must be uncovered when stage 'B' is completed for further fording operations.		

Fig 2 Waterproofed equipment markings

Component Location

36 Refer to Fig 3 for the location of engine and ancillary components at the front of the vehicle.

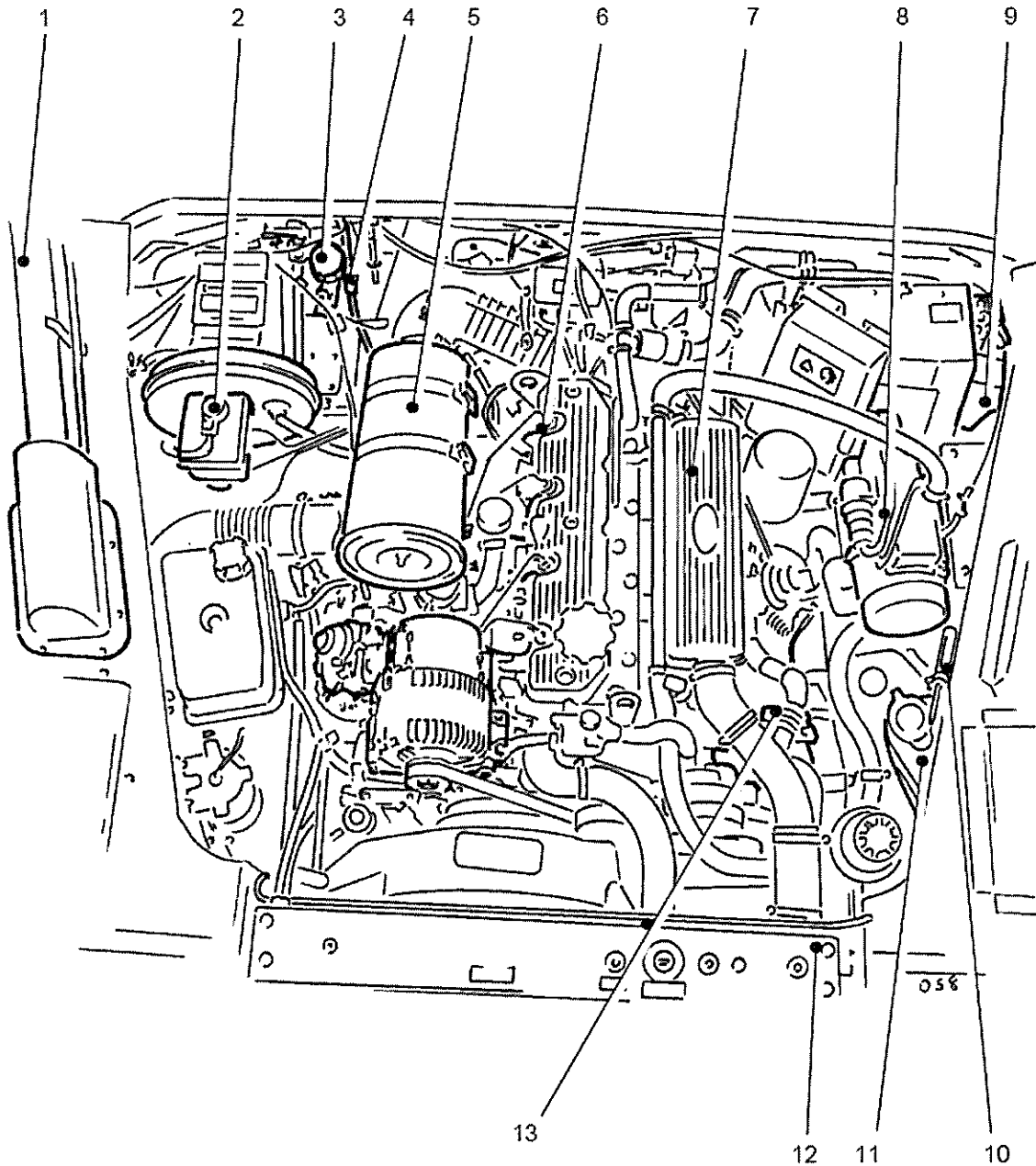

- | | |
|--------------------------------|--------------------------------|
| 1 High level engine air intake | 8 Webasto heater |
| 2 Brake fluid reservoir | 9 Vehicle heater |
| 3 Clutch fluid reservoir | 10 Alternator disconnect tool |
| 4 Fuel tank breather | 11 Windscreen washer reservoir |
| 5 Air cleaner | 12 Intercooler |
| 6 Heater plugs | 13 Alternator |
| 7 Inlet manifold | |

Fig 3 Component layout

WATERPROOFING STAGE 'B'

CAUTION

EQUIPMENT DAMAGE. Before commencing waterproofing stage 'B', ensure that a thorough examination of build standard waterproofing has been completed, in accordance with Para 31 of this instruction.

SEQUENCE OF OPERATIONS

37 Carry out this Preparation for Special Environment as follows:

NOTE

Refer to Fig 3, Component layout, for the location of individual engine/ancillary components.

TASK 1 VEHICLE BATTERIES

WARNINGS

- (1) **NO SMOKING OR NAKED FLAMES. LEAD ACID BATTERIES PRODUCE POTENTIALLY EXPLOSIVE GASES.**
- (2) **BATTERIES CONTAIN CORROSIVE ACID ELECTROLYTE. WEAR PROTECTIVE GLOVES AND GOGGLES WHEN HANDLING BATTERIES.**

38 Remove the passenger seat cushion and the battery compartment cover. Disconnect the negative earth cable from the battery. Temporarily refit the battery compartment cover to prevent accidental short circuiting during stage 'B' waterproofing.

TASK 2 ENGINE AIR CLEANER**CAUTION**

EQUIPMENT DAMAGE. It is essential that all air cleaner hose connections and the cleaner end cover are secured correctly to provide a watertight seal on the air cleaner casing.

NOTE

This task is to be carried out with the assistance of a vehicle mechanic.

39 Check that the air cleaner end cover is correctly secured against the rubber seal on the cleaner body.

39.1 Check that all hoses connected to the air cleaner, intake manifold and intercooler are secure and in good condition.

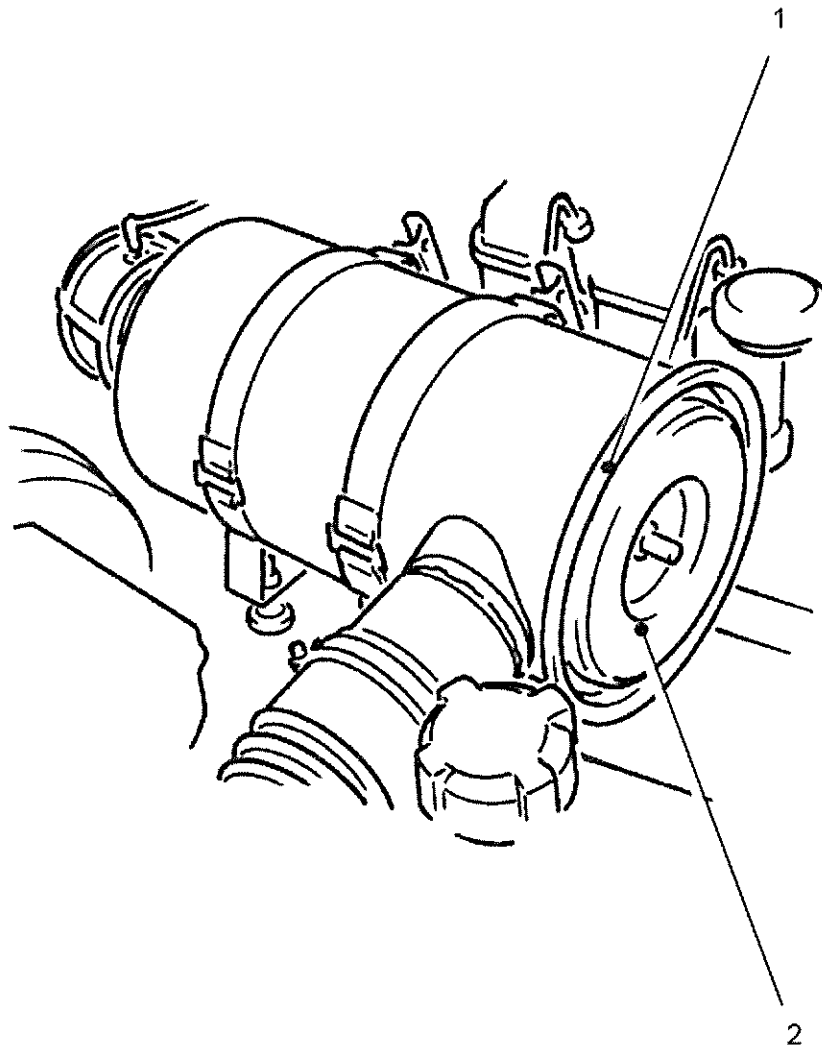

1 Rubber seal 2 End cover

Fig 4 Air cleaner

TASK 3 ALTERNATOR

CAUTION

EQUIPMENT DAMAGE. It is essential the procedure described in this task is followed exactly, to isolate the charging system and avoid short circuiting.

NOTES

- (1) This task to be carried out with the assistance of a vehicle mechanic.
- (2) The two alternator multi-plugs are located on a bracket attached to the alternator.

40 Locate the multi-plug disconnect tool attached to the left hand front wing, above the windscreen washer reservoir. Remove the tool from its clip.

40.1 Using the tool as shown in Fig 5, depress the multi-plug latch, applying light pressure only and disconnect the following:

40.1.1 Red colour coded multi-plug.

40.1.2 Blue colour coded multi-plug.

40.2 Replace the disconnect tool to its original location.

40.3 Connect the free section of the red multi-plug to the fixed section of the blue multi-plug.

40.4 Connect the free section of the blue multi-plug to the fixed section of the red multi-plug.

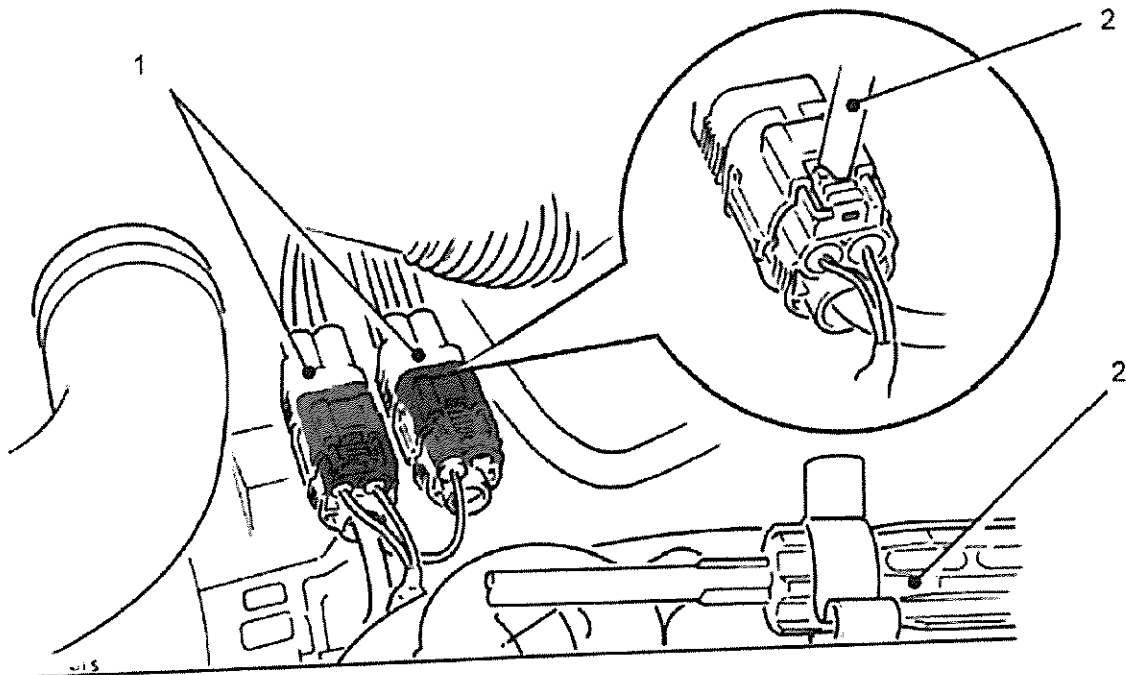

1 Multi-plugs 2 Disconnect tool

Fig 5 Alternator disconnection

40.5 Slacken the wing screw clamp and disconnect the breather hose from the rear of the alternator. Remove the clamp from the hose and place in a plastic bag (item 27).

NOTE

The breather hose is located on the underside of the alternator end cover. Access is difficult and care must be taken not to damage any of the intercooler pipes.

40.6 Position the breather hose clear of moving parts and exhaust manifold.

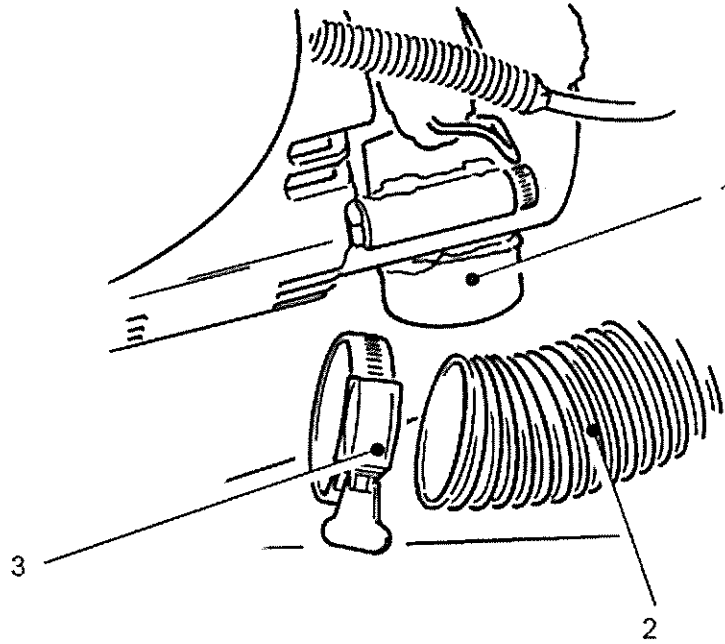

- | | |
|-----------------|---------|
| 1 End cover | 3 Clamp |
| 2 Breather hose | |

Fig 6 Alternator breather hose

TASK 4 CLUTCH FLUID RESERVOIR

41 Ensure the reservoir filler cap is tight. Stretch a rubber cover (item 5) over cap so that edge of cover seals on reservoir body.

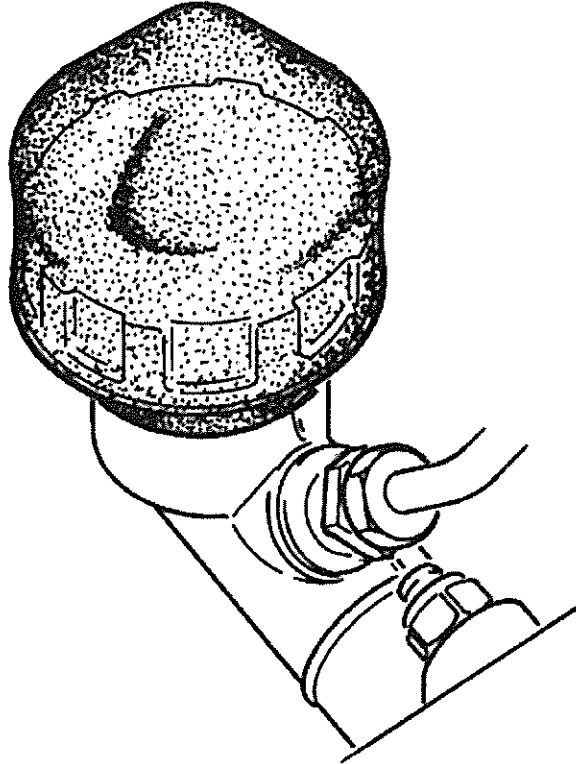

Fig 7 Clutch fluid reservoir

TASK 5 BRAKE FLUID RESERVOIR

WARNING

BRAKE FLUID. HYDRAULIC FLUID IS A TOXIC SUBSTANCE WHICH MUST NOT BE CONSUMED OR ALLOWED TO COME INTO SKIN/EYE CONTACT. IN THE EVENT OF SLIGHT SKIN/EYE CONTACT, THOROUGHLY RINSE THE AFFECTED AREA WITH WATER. IF THERE IS EXCESSIVE SKIN/EYE CONTACT OR INGESTION/INHALATION SEEK MEDICAL ATTENTION IMMEDIATELY.

CAUTION

BRAKE FLUID. Brake fluid will damage paintwork, if any brake fluid comes into contact with the paintwork, immediately wash down with a large quantity of freshwater and wipe clean with a soft cloth.

42 Depress the latch as shown in Fig 8 and disconnect the brake fluid level sensor multi-plug. Connect a blanking plug (item 14) to the harness multi-plug.

NOTE

With the blanking plug (item 14) fitted, the red brake circuit check warning light on the centre console will illuminate at all times with the ignition key in the 'ON' position.

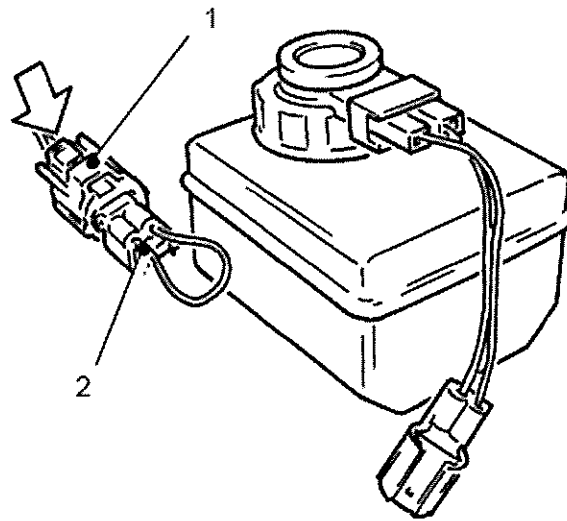

1 Harness multi-plug 2 Blanking plug (item 14)

Fig 8 Brake fluid level sensor

42.1 Slacken the reservoir filler cap sufficiently to gain access. **DO NOT** remove the filler cap.

42.2 Stretch a rubber cover (item 4) over the cap and sensor harness. Position the open end of the cover between the edge of the cap and the reservoir to form a sealing surface, as shown in Fig 9. Tighten the cap, clamping the cover to the reservoir body.

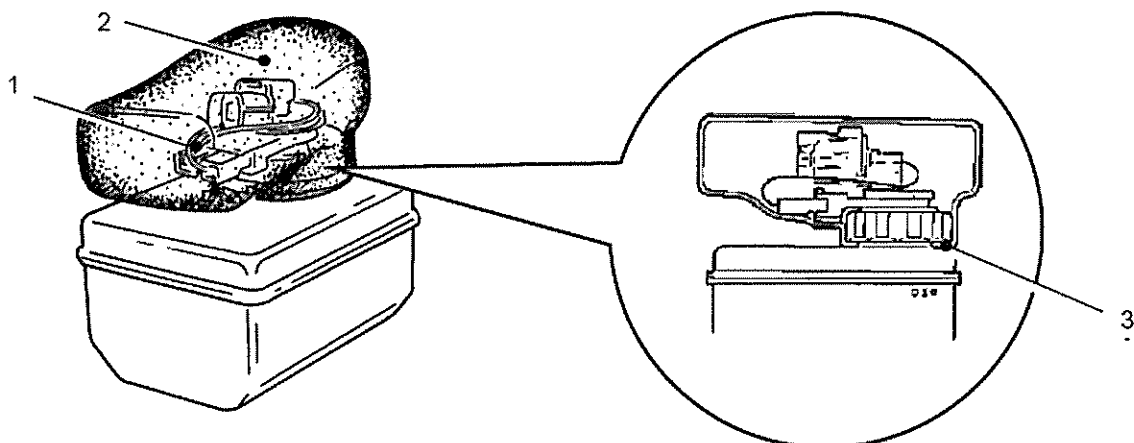

1 Sensor harness 3 Cover sealing surface
2 Rubber cover

Fig 9 Brake fluid reservoir

TASK 6 HEATER PLUGS

NOTES

- (1) Do not remove any engine parts when carrying out this task.
 - (2) For clarity the air cleaner and breather cyclone are not shown in Fig 10.
- 43 Fill spray container (item 24) with PX-24 water displacement fluid (item 34).
- 43.1 Spray an even coat of PX-24 from container over each of the four heater plug terminal connections for protection against the effects of sea water.

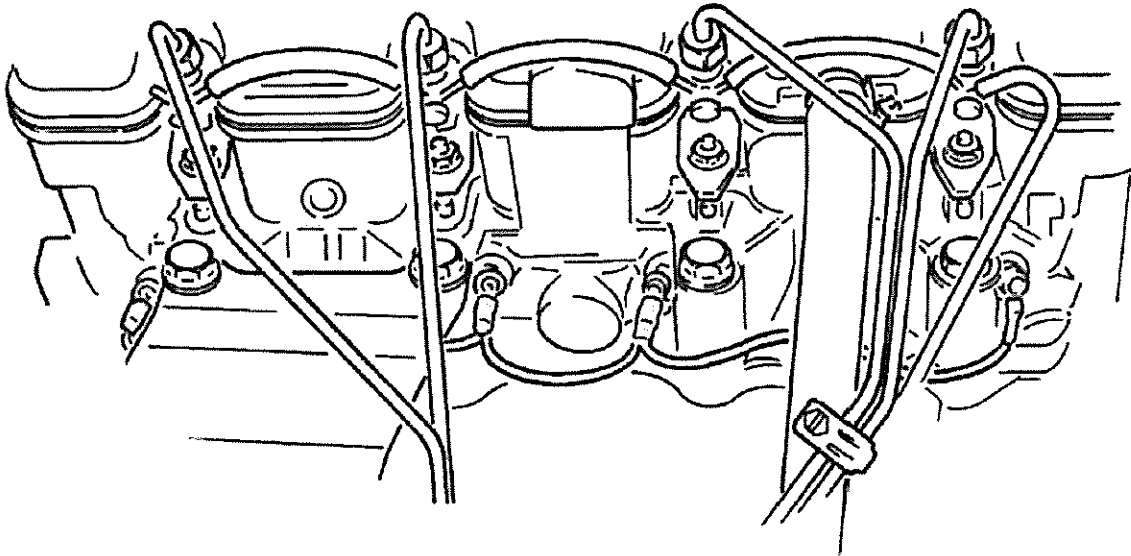

PX-24

Fig 10 Heater plugs

TASK 7 WINDSCREEN WASHER RESERVOIR

WARNING

HEALTH HAZARD. FLUID AL 11 IS HIGHLY INFLAMMABLE. THE PREPARATION OF THE FLUID FOR WINDSCREEN WASHERS IS TO BE CARRIED OUT IN THE OPEN AND AWAY FROM NAKED FLAME. MINIMUM PRECAUTION AFTER USE IS TO WASH ANY AFFECTED SKIN AREAS WITH SOAP AND WATER.

CAUTION

EQUIPMENT DAMAGE. It is essential that the windscreen washer reservoir is filled as detailed in this task to avoid contamination by sea water and subsequent damage to the screen wash equipment.

- 44 Fill the windscreen washer reservoir to the bottom of the filler neck with a mixture of AL11 (item 38) and water. Refit the reservoir filler cap.

TASK 8 FUEL TANK BREATHER**NOTE**

Fuel tank breather connector is located in the engine compartment adjacent to the clutch fluid reservoir.

45 Depress the connector latches as shown in Fig 11 and disconnect the fuel tank breather pipe from the blue colour coded vent pipe.

45.1 Connect the fuel tank breather pipe to the red colour coded pipe of the component breather system.

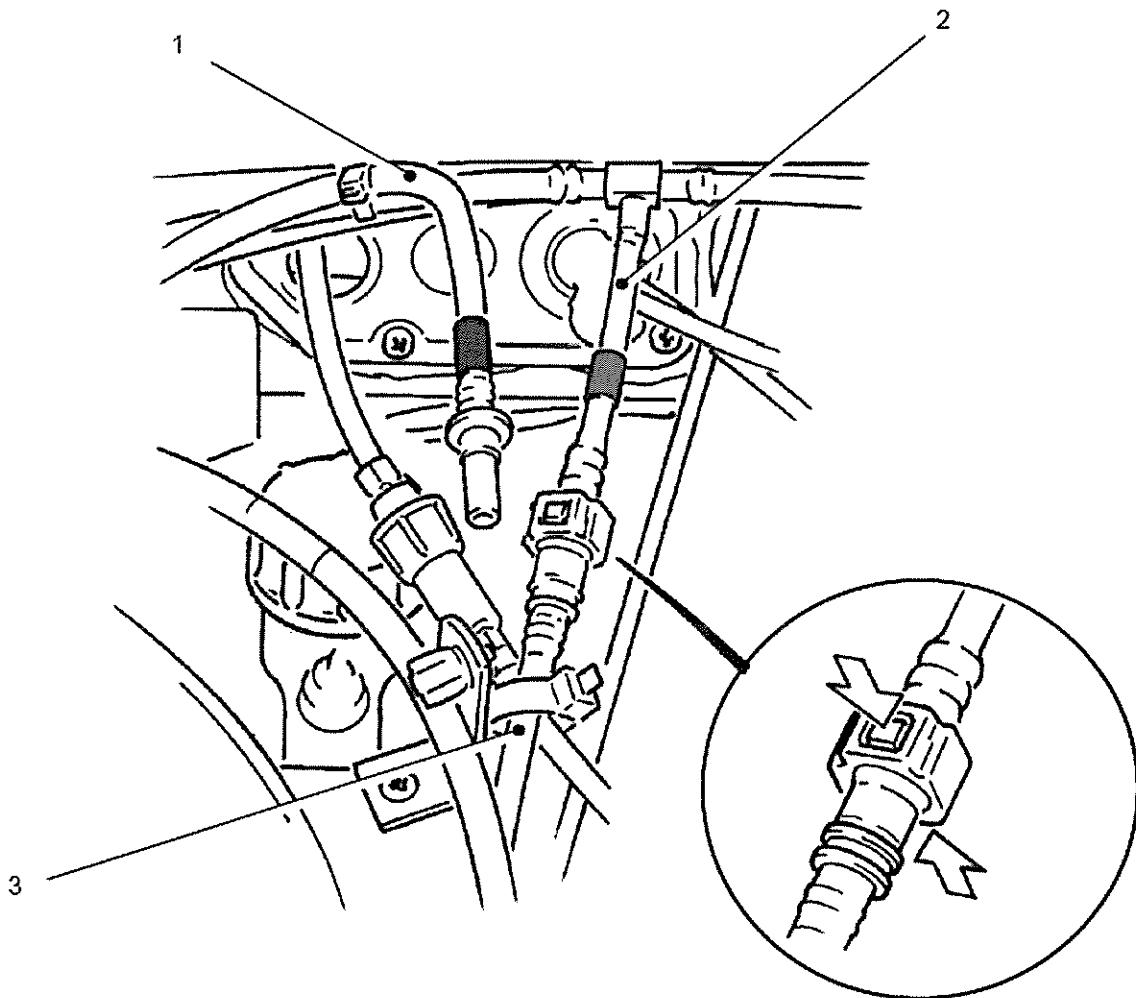

1 Blue colour coded, vent pipe

2 Red colour coded, component breather system

3 Fuel tank breather pipe

Fig 11 Fuel tank breather

TASK 9 WEBASTO HEATER

NOTE

This task to be carried out with the assistance of a vehicle mechanic.

46 Slacken the wing screw clamp securing the intake pipe to the heater and remove the intake pipe. Remove the clamp from the pipe, it will be required later in this task.

46.1 Slacken the clamps and disconnect the exhaust pipe from the heater. Remove the exhaust pipe connection sleeve complete with clamps. Do not remove any other exhaust system parts.

46.2 Place air intake pipe and exhaust connection sleeve in a plastic bag (item 27).

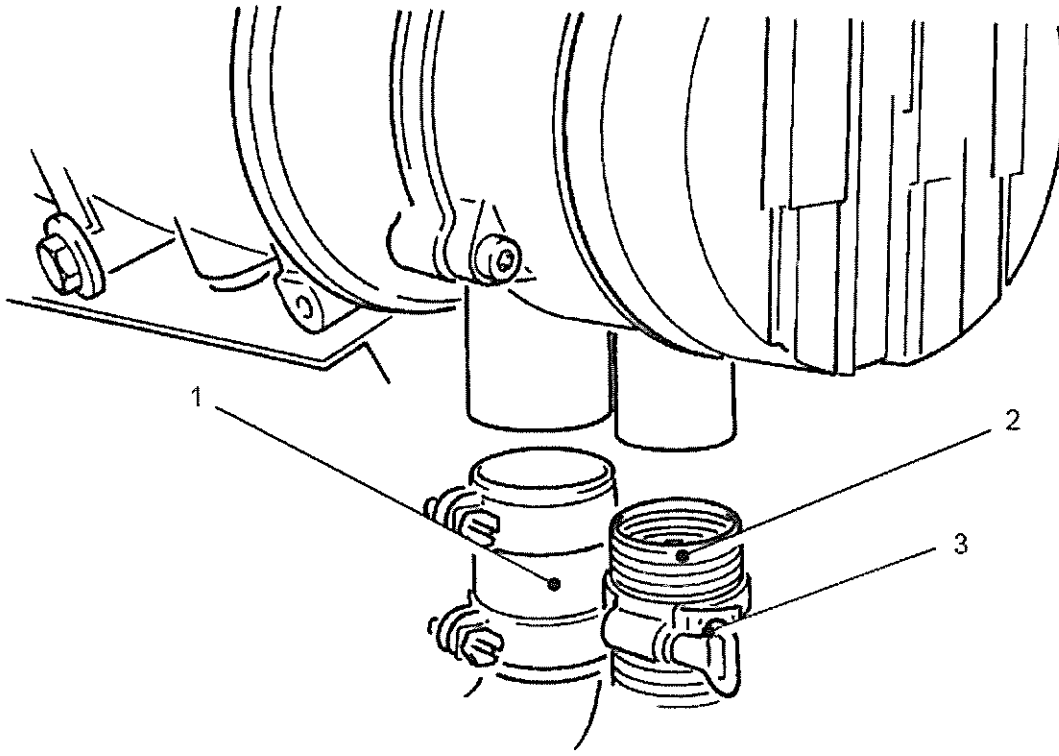

- 1 Exhaust connection sleeve
- 2 Intake pipe
- 3 Wing clamp

Fig 12 Webasto heater

46.3 Fit a cap (item 7) over the heater air intake port. Secure cap with the original intake pipe clamp.

46.4 Fit a cap (item 8) over the heater exhaust port. Secure cap with clamp (item 9).

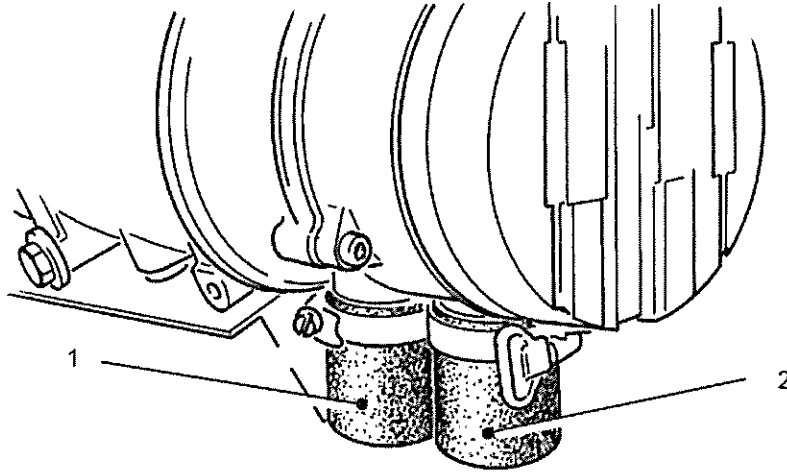

1 Exhaust cap 2 Intake cap

Fig 13 Webasto caps

46.5 Locate the Webasto control switch on the centre console in the driver's cab. Ensure the switch is in the 'OFF' position. Prise the control knob from the switch and place in a plastic bag (item 27). This is done to prevent accidental operation of the heater during fording operations.

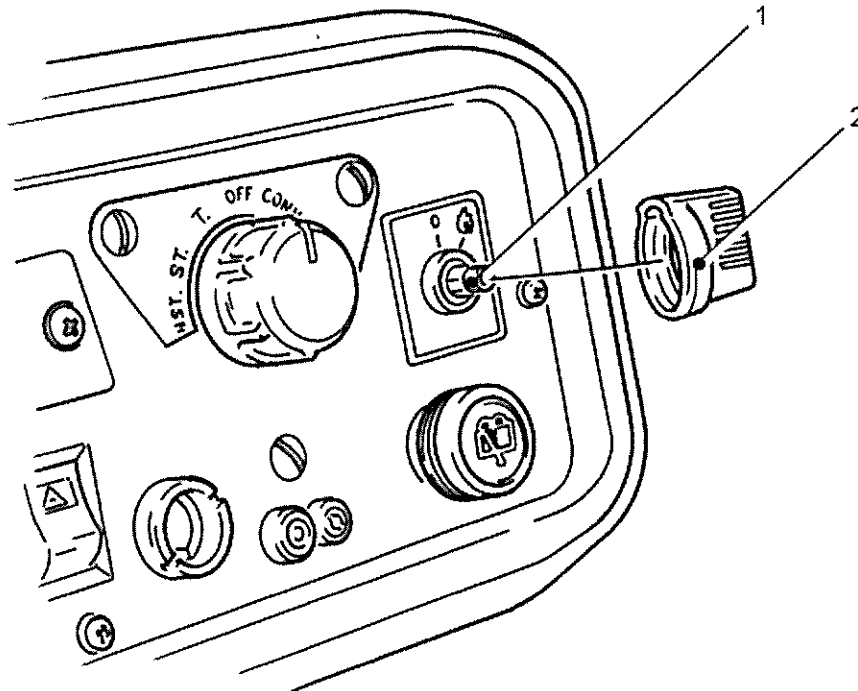

1 Switch 2 Control knob

Fig 14 Webasto switch

TASK 10 HEATER

NOTE

The two heater multi-plugs are attached to the heater unit at the rear of the engine compartment.

47 Depress the latch as shown in Fig 15 and disconnect the grey and orange multi-plugs.

47.1 Connect the grey multi-plug to the orange multi-plug blank.

47.2 Connect the orange multi-plug to the grey multi-plug.

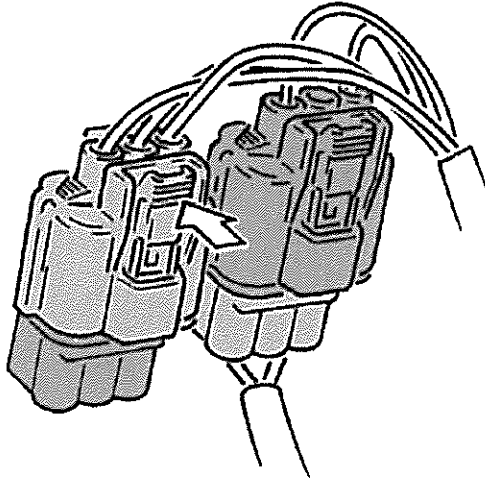
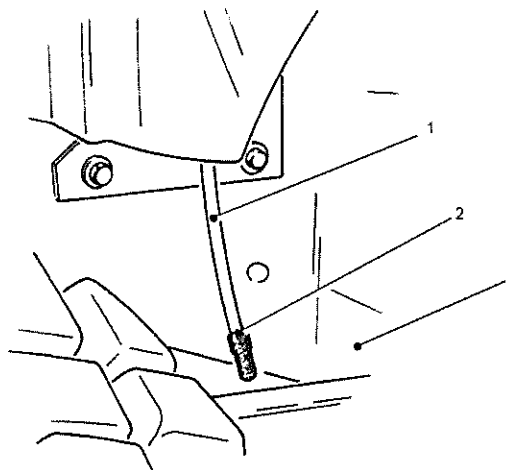

Fig 15 Heater multi-plugs

NOTE

The motor drain tube is situated at the rear of the left hand front wheel arch adjacent to the chassis side member. Access is gained beneath the left hand front wing.

47.3 Fit a cap (item 13) over the end of the heater motor drain tube.



- | | |
|--------------|-----------------------|
| 1 Drain tube | 3 Chassis side member |
| 2 Cap | |

Fig 16 Motor drain

TASK 11 STEERING COLUMN SWITCHES

48 Release the indicator and wiper switch rubber covers from the steering column switch box. DO NOT REMOVE the rubber covers from the switch stalks. Fit the large end of the covers inside the apertures on the box.

48.1 Stretch a rubber cover (item 6) over indicator switch, position edge of cover over the boss on the steering column box.

48.2 Stretch a rubber cover (item 6) over wiper switch, position edge of cover over the boss on the steering column box.

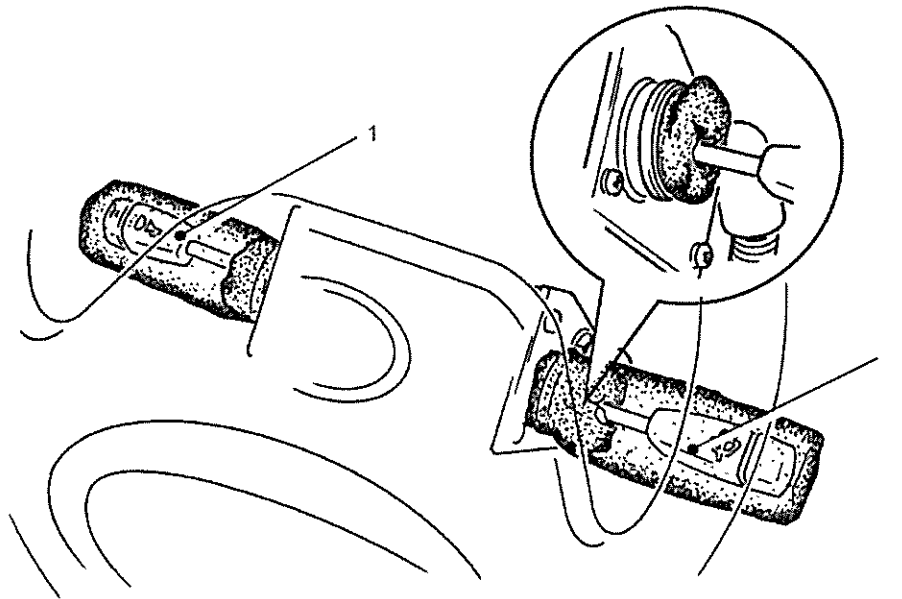

1 Rubber cover

Fig 17 Steering column switches

TASK 12 DELETED

49 Deleted.

Fig 18 Deleted

TASK 13 INTER-VEHICLE START SOCKET

50 The Inter-vehicle start socket is located in the passenger side footwell. Remove socket cap. Apply an even coat of silicone compound (item 33) over socket threads and socket rubber seal using an artist's brush (item 28). Refit and tighten cap.

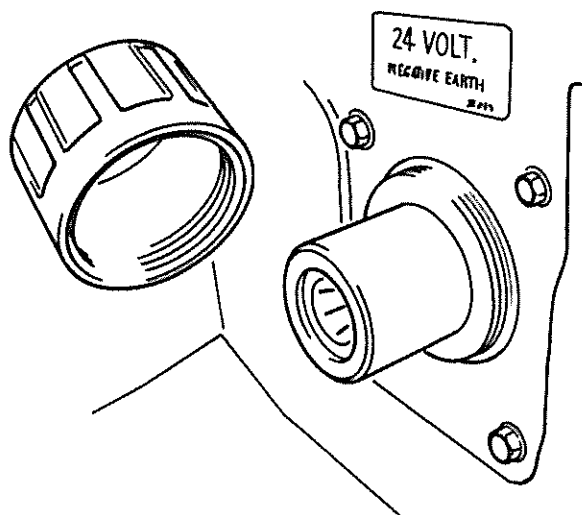

Silicone compound

Fig 19 Inter-vehicle start socket

TASK 14 FRONT WIPER MOTOR BOX

51 Press a tapered silicone plug (item 17) into the wiper box drain hole on the underside of the box. Ensure the plug is a firm fit with no possibility of it being dislodged.

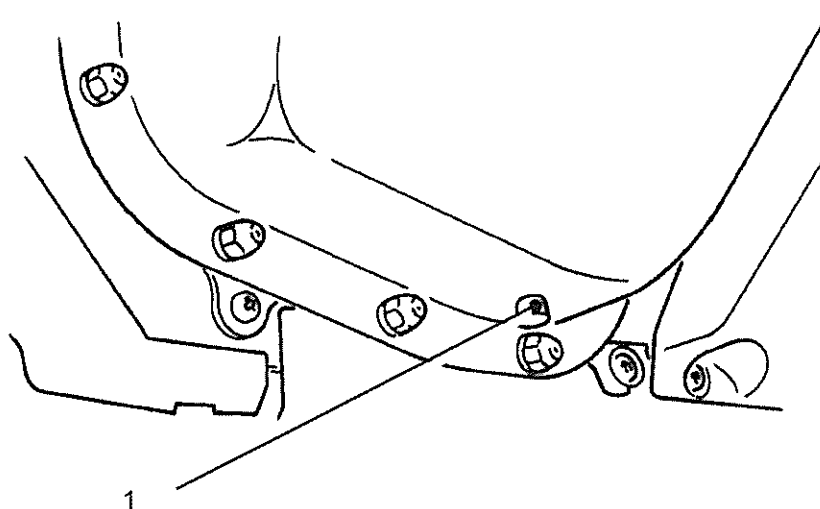

1 Tapered silicone plug

Fig 20 Front wiper box

TASK 15 FRONT SEAT BELTS**NOTE**

This task to be carried out with the assistance of a vehicle mechanic.

52 Remove inertia reel seat belt units and anchorage engagement/release assembly stalks from vehicle. Discard the cardboard washers from the belt and stalk securing bolts; these are only used for production assembly purposes by the vehicle manufacturer. Refit all securing bolts, nuts, spacers and remaining washers to vehicle.

52.1 Place all seat belt equipment in a zipped stowage bag (item 23).

TASK 16 REAR SEAT BELTS

53 Uncouple and remove the rear static seat belts/unbolt rear Auto Retractor (AR) seat belts and anchorage/release stalks from the vehicle. Refit bolts.

53.1 Place the rear seat belts in a zipped stowage bag (item 23).

TASK 17 REAR WIPER MOTOR BOX – HARD TOP VEHICLE ONLY**NOTE**

The rear wiper box is located on the inside of the rear door.

54 Press a tapered silicone plug (item 17) into the wiper box drain hole on the underside of the box. Ensure the plug is a firm fit with no possibility of it being dislodged.

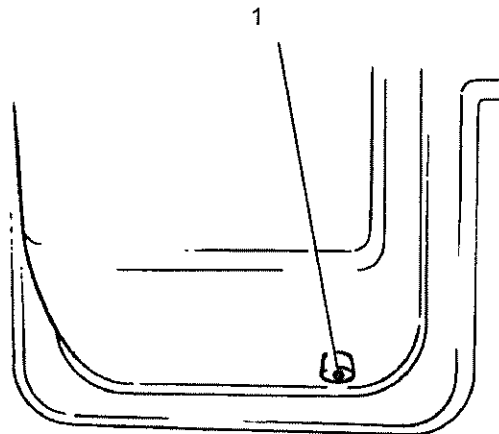

- | | | | |
|---|---------------|---|--------------|
| 1 | Spacer block | 3 | Rubber cover |
| 2 | Adapter plate | | |

Fig 21 Rear wiper box

TASK 18 FLYWHEEL HOUSING

55 Fit and tighten drain plug (item 16) to flywheel housing.

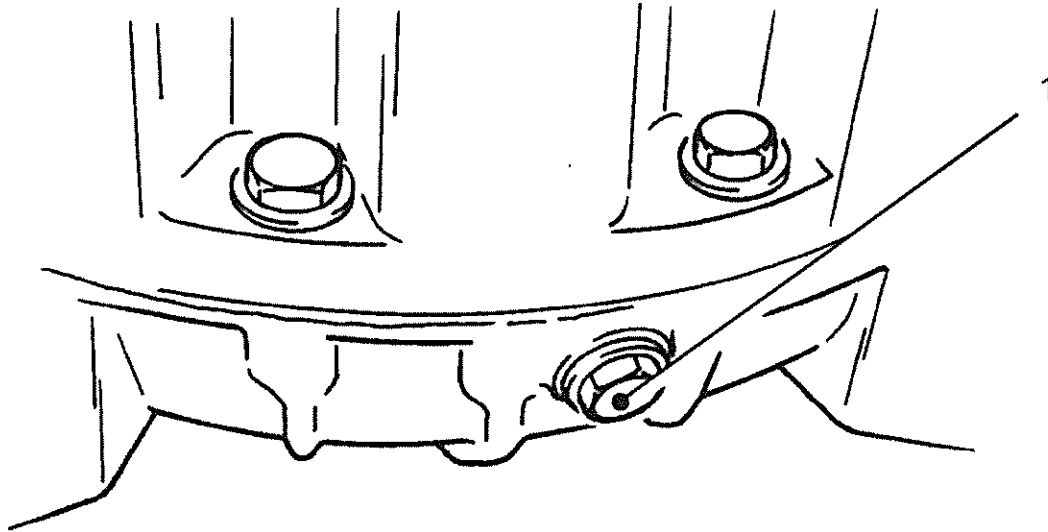

1 Drain plug

Fig 22 Flywheel housing

TASK 19 NUMBER PLATE LAMP

56 Stretch a cover (item 18) over the number plate lamp and lamp adaptor plate. Position edge of cover around the lamp spacer block.

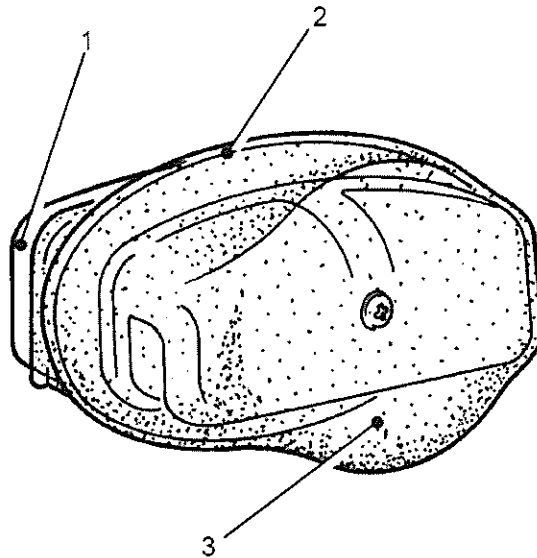

1 Spacer block 3 Rubber cover
2 Adapter plate

Fig 23 Number plate lamp

TASK 20 NATO 12 PIN TOWING SOCKET

57 When not in use, lift the spring loaded cover and apply a liberal coat of silicone compound (item 33) to the socket terminals using an artist's brush (item 28). Close cover.

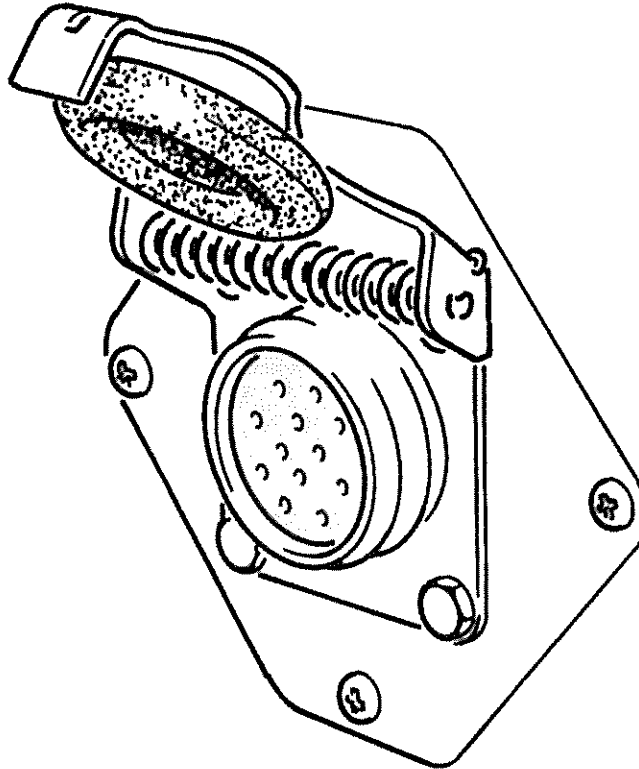

Silicone compound

Fig 24 Towing socket terminals

TASK 21 CENTRE CONSOLE

CAUTIONS

- (1) **EQUIPMENT DAMAGE.** It is essential that all covers are correctly located to provide a watertight seal on the centre console.
- (2) **EQUIPMENT DAMAGE.** It is essential that the waterproofing cover is fitted before the drain plug. This is to avoid air being trapped in the console during fitting that would prevent correct location of the cover.

58 Remove the ignition key from the key ring and fit the key to the ignition switch. Ensure that all switches in the centre console are in the 'OFF' position. Place all the remaining keys and key ring in a zipped stowage bag (item 23).

58.1 Stretch a rubber cover (item 5) over the ignition switch boss on the console cover (item 2). Press the cover through the switch aperture as shown in Fig 25. Ensure the rubber cover remains fully located on the switch boss. Secure the rubber cover to the switch boss with a cable tie (item 31).

58.2 Apply a thin even coat of silicone compound (item 33) to the edge of the console cover using an artist's brush (item 28). Ensure the silicone compound does not contaminate the ignition switch rubber cover and is applied only to the areas shown in Fig 25.

NOTE

Silicone compound is applied to aid the fitting of the console cover.

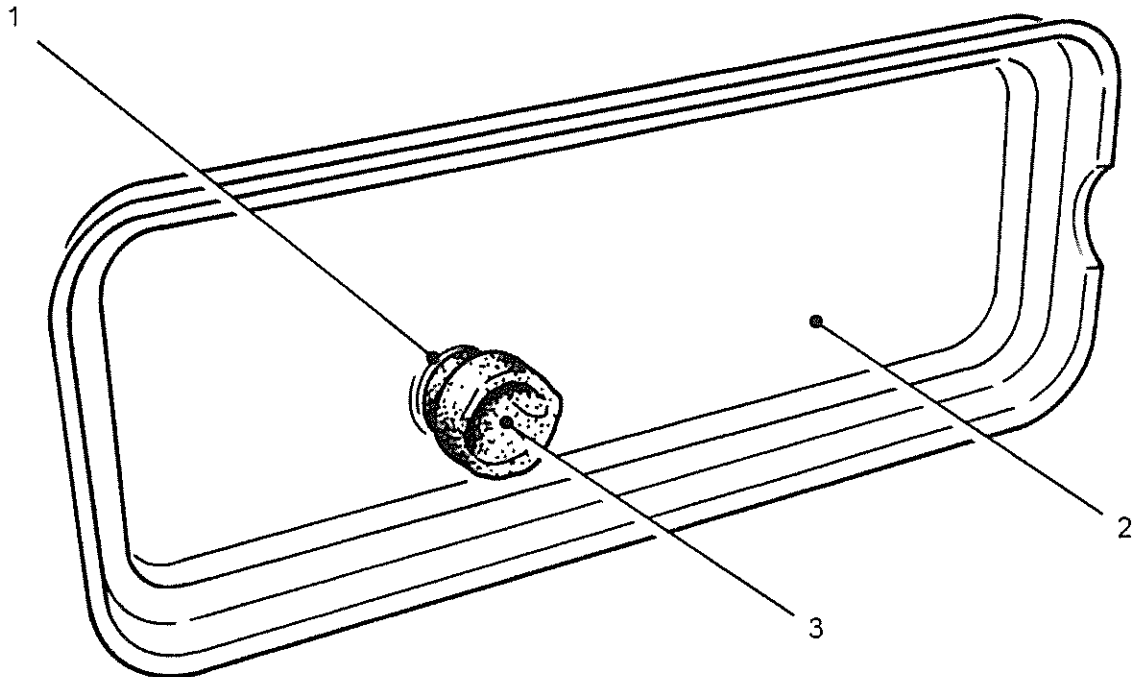

- 1 Cable tie
- 2 Console cover
- 3 Rubber cover

Silicone compound

Fig 25 Console cover

58.3 Position cover centrally over the rubber seal around the edge of the centre console with the switch aperture located over the ignition switch. Carefully press the cover over the seal until it is fully located onto the box. Ensure all edges of the cover are fully located.

58.4 Loop the strap-console cover (item 3) over the left hand edge of the centre console, twist the strap to form a second loop. Pass the second loop over the front of the cover and secure to the right hand edge of the console. Ensure that the retaining strap is located over each of the four corners of the centre console.

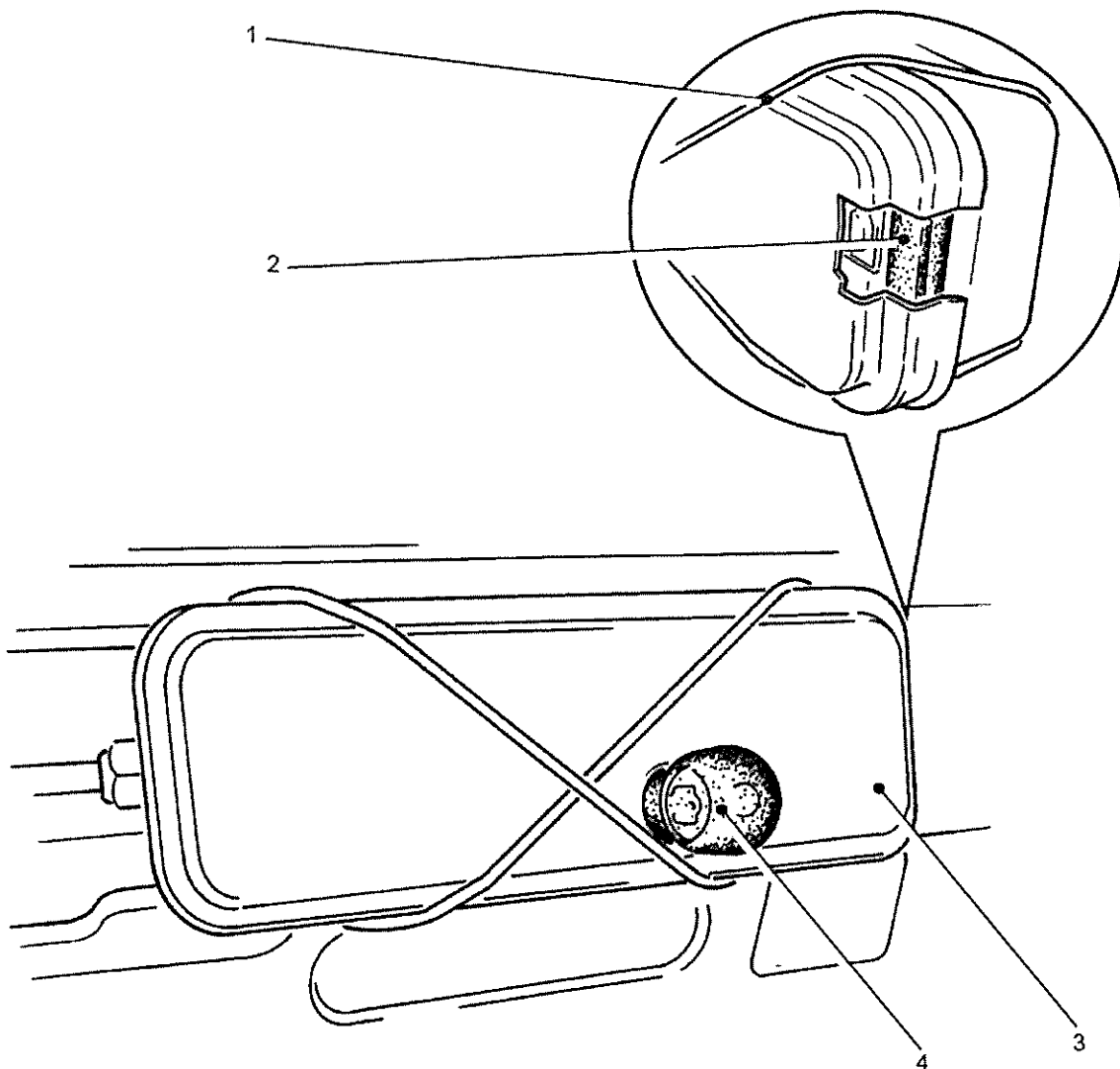

- | | |
|---------------|-----------------|
| 1 Strap | 3 Console cover |
| 2 Rubber seal | 4 Rubber cover |

Fig 26 Centre console

58.5 Locate the drain hole on the left hand side of the console below the fuse cover. Press a tapered silicone plug (item 17) into the drain hole. Ensure the plug is a tight fit with no possibility of it being dislodged.

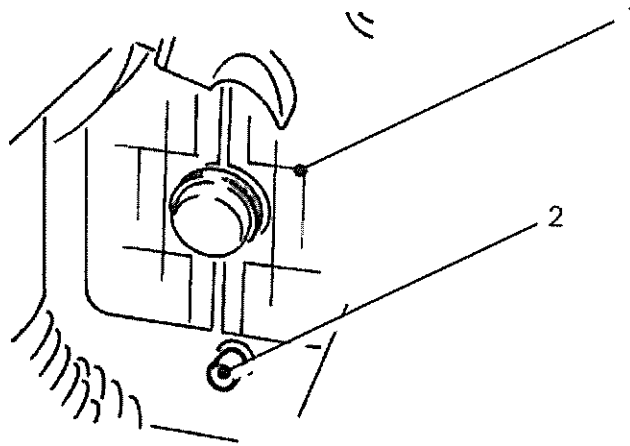

1 Fuse cover 2 Tapered silicone plug

Fig 27 Console drain

58.6 Ensure the map lamp bulb holder is screwed tight to the lamp stalk. Locate the rubber lamp cover attached to the dashboard and fit over the bulb holder. If the rubber cover is missing or damaged, fit rubber cover (item 10) over the bulb holder.

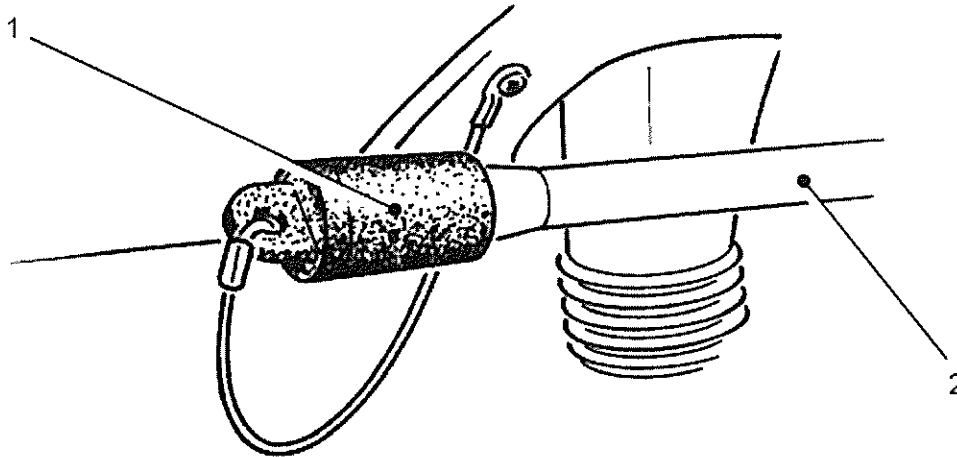

1 Rubber cover 2 Lamp stalk

Fig 28 Map lamp

58.7 With the covers fitted to the centre console the procedure for starting the engine is as follows:

- 58.7.1 Grip the ignition key through the rubber cover and turn to the first position.
- 58.7.2 Wait approximately ten seconds for the engine heater plugs to operate.
- 58.7.3 Start engine.

TASK 22 BATTERIES (2)**WARNINGS**

- (1) **NO SMOKING OR NAKED FLAMES. LEAD ACID BATTERIES PRODUCE POTENTIALLY EXPLOSIVE GASES.**
- (2) **BATTERIES CONTAIN CORROSIVE ACID ELECTROLYTE. WEAR PROTECTIVE GLOVES AND GOGGLES WHEN HANDLING BATTERIES.**

NOTE

Deleted.

59 Reconnect the negative earth cable disconnected at Task 1 to the battery. Apply a liberal coat of PX-7 grease (item 36) to all battery terminals, ensuring they are completely covered. Refit the covers over the battery terminals. Refit the battery compartment cover and front seat cushion to the vehicle.

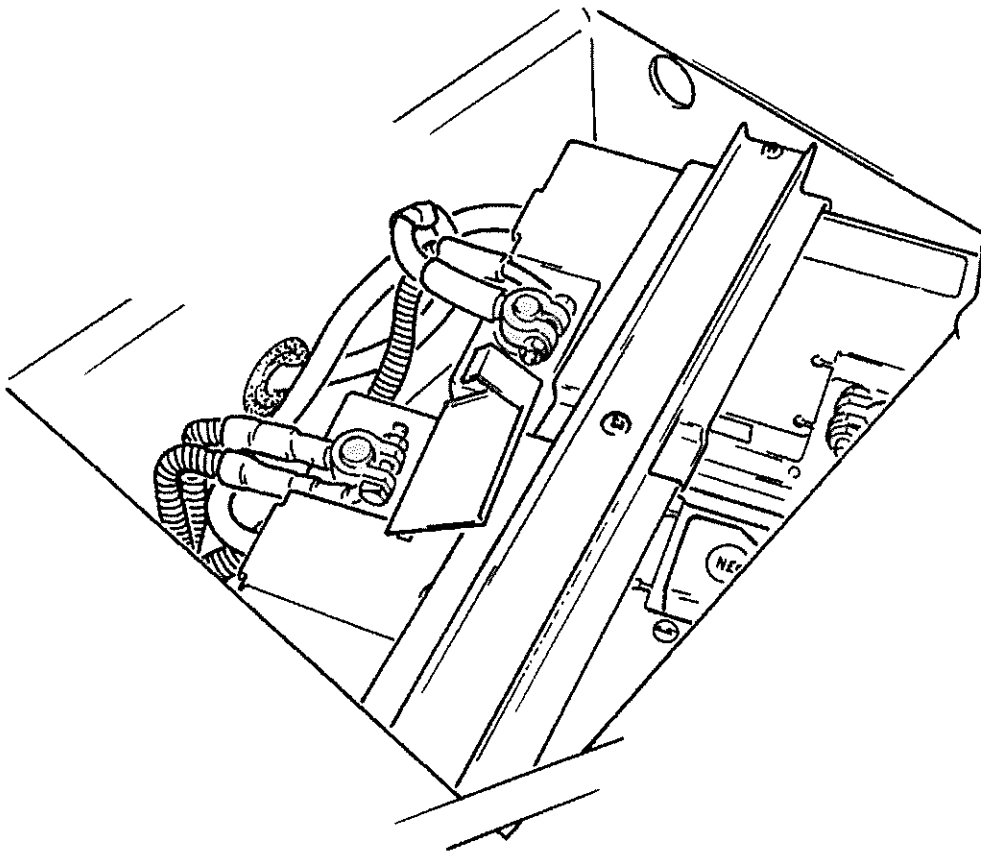

Grease PX-7

Fig 29 Batteries

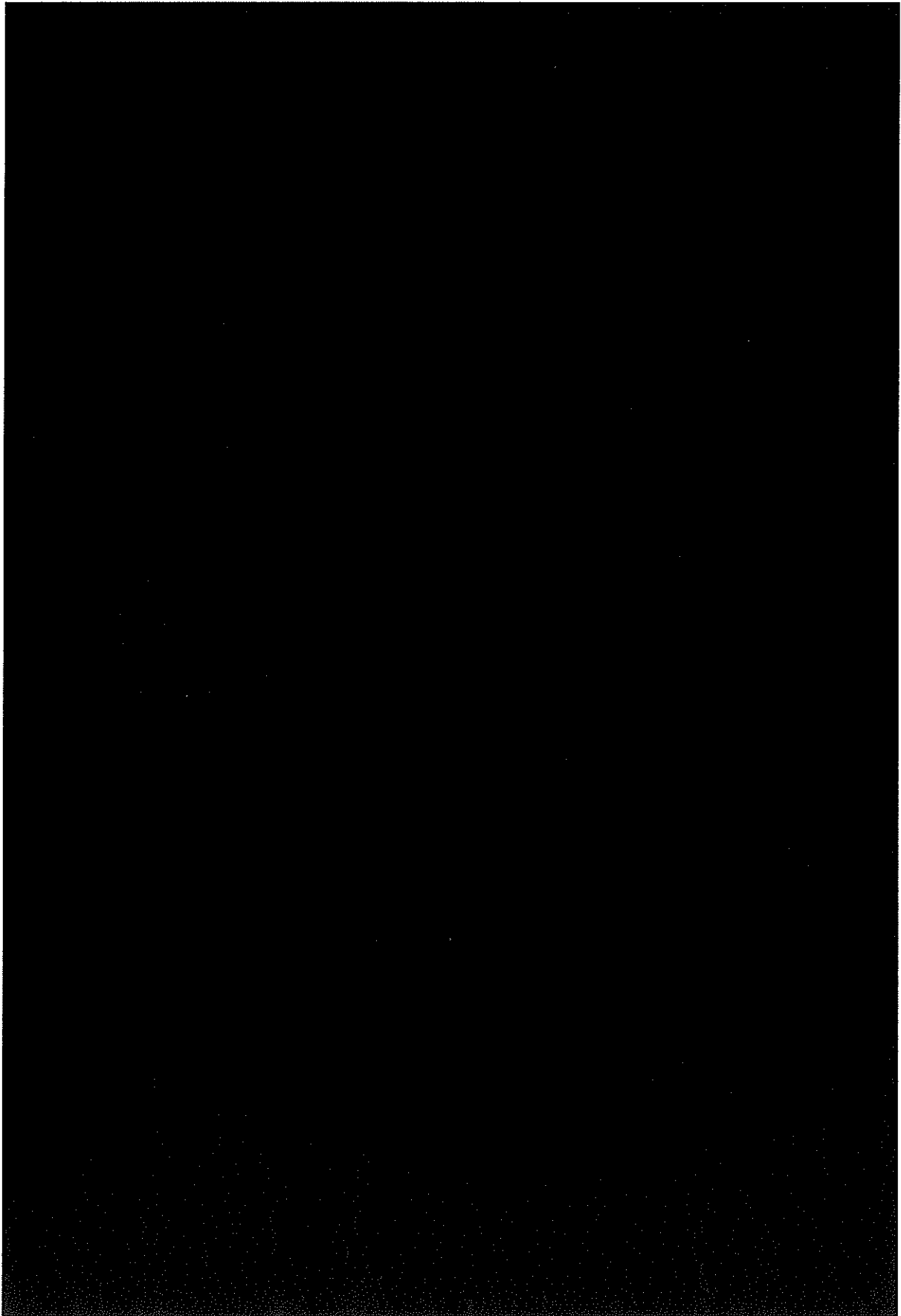

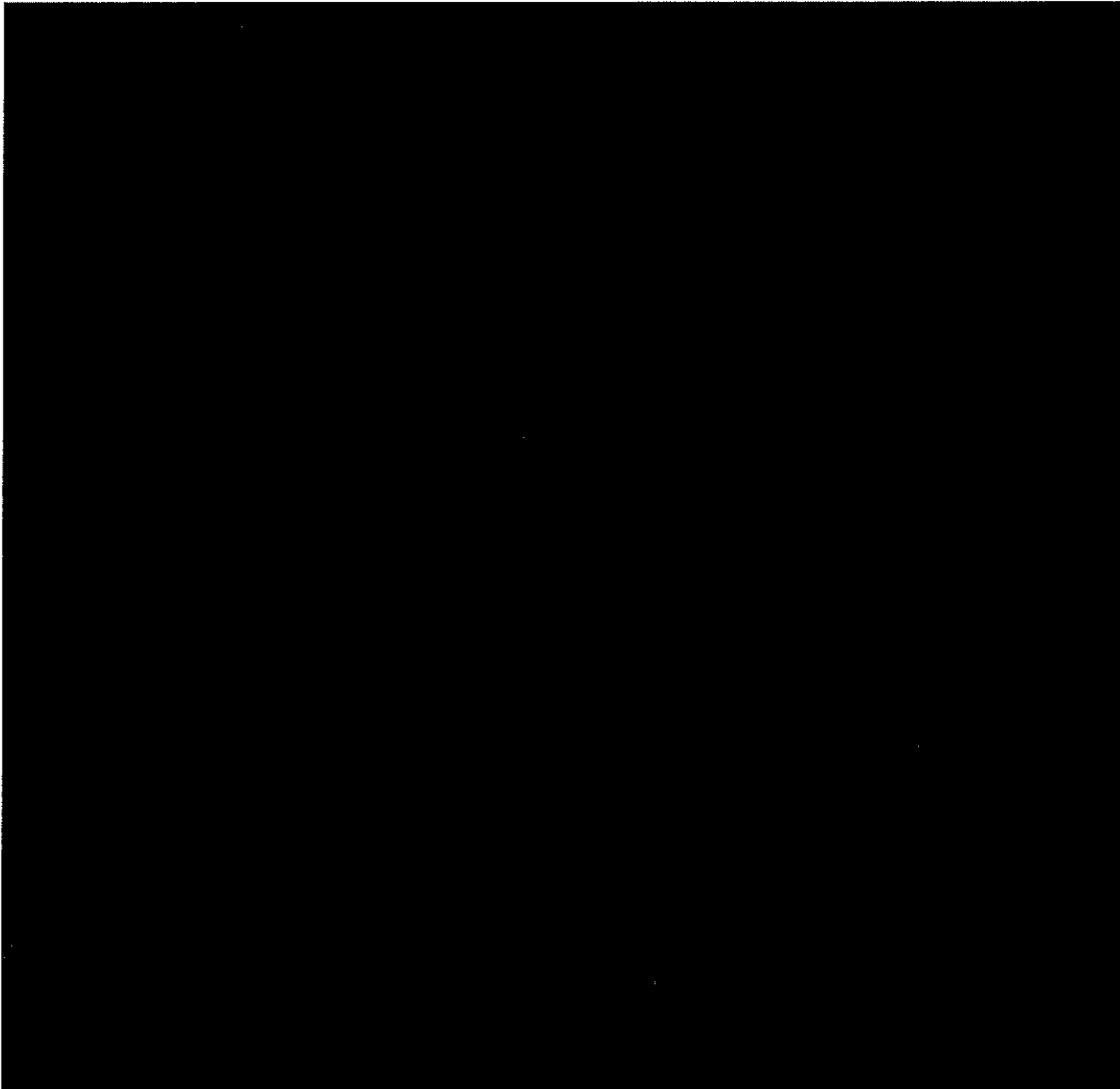

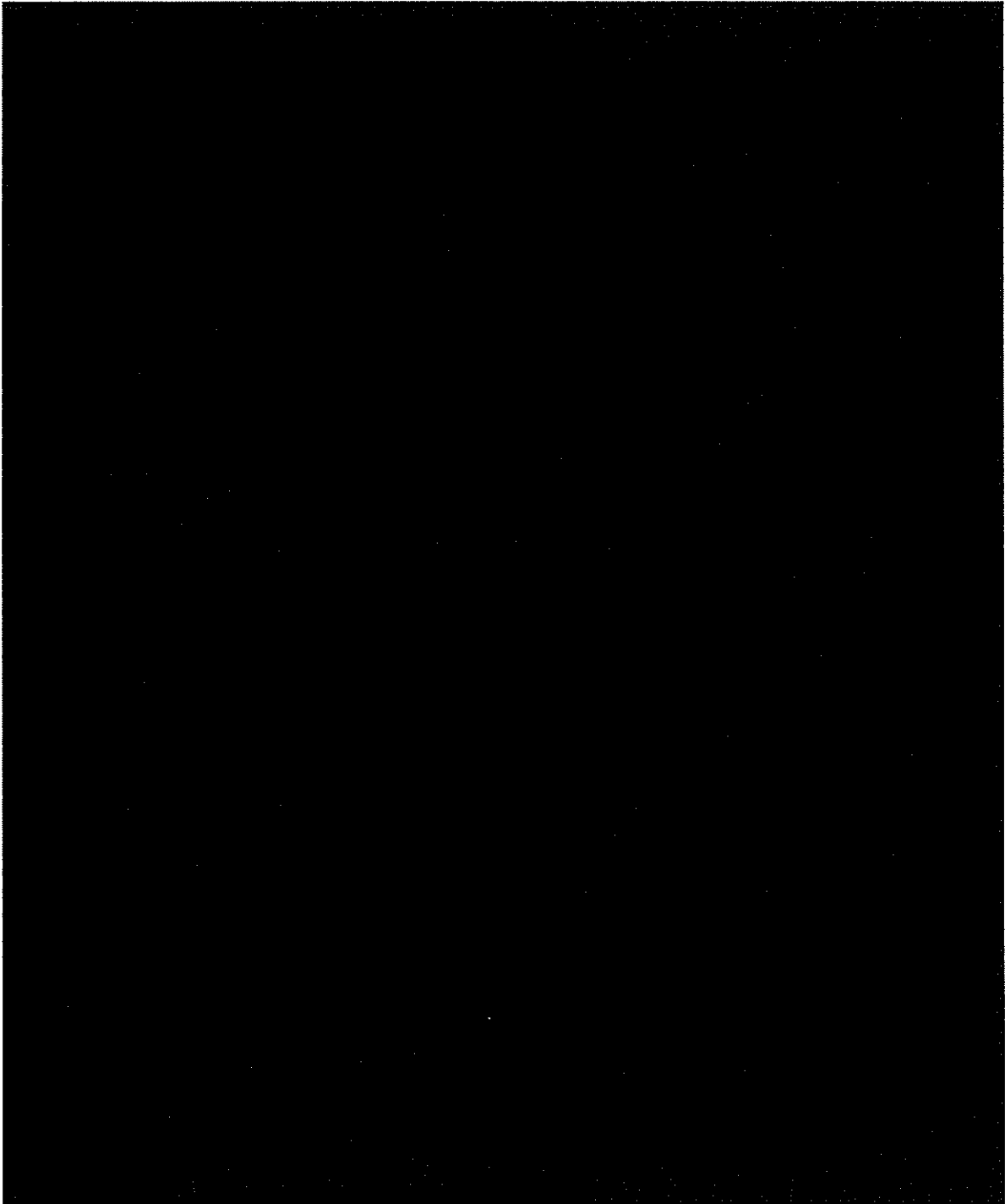

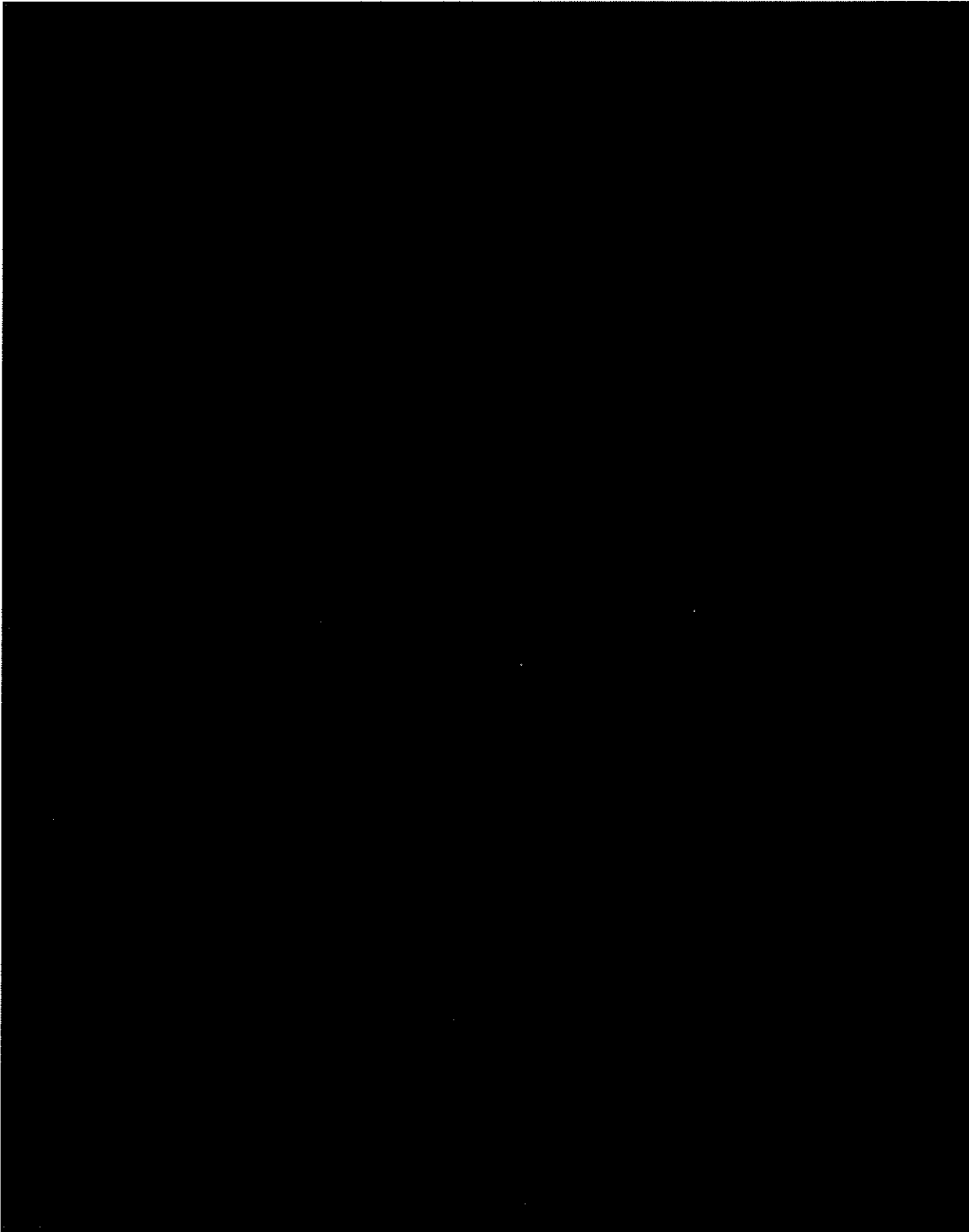

TASK 27 ESCAPE HATCH – SOFT TOP VEHICLE

WARNING

PERSONNEL SAFETY. THE ESCAPE HATCH PROVIDES A MEANS OF ESCAPE FROM THE VEHICLE IN AN EMERGENCY. THE ESCAPE HATCH SECTION OF THE HOOD MUST BE OPEN AND SECURED FOR ALL FORDING OPERATIONS.

64 From inside the vehicle, release the two hooked ends of the winterised lining support straps from the cam lock buckles on top of the windscreen surround. Refit the hooked ends to the support straps. Coil the straps and secure to the roll over cage behind the front seats for safe stowage.

64.1 Release the Velcro strips securing the driver's cab lining only and remove the lining from the vehicle. Fold and stow the lining in the rear side of the vehicle between the rear compartment lining and the hood.

64.2 Unzip the hood, DO NOT OPEN FULLY, stop just short of the right hand hood joint as shown in Fig 34.

64.3 Referring to Fig 34, roll up the hood from the left hand corner.

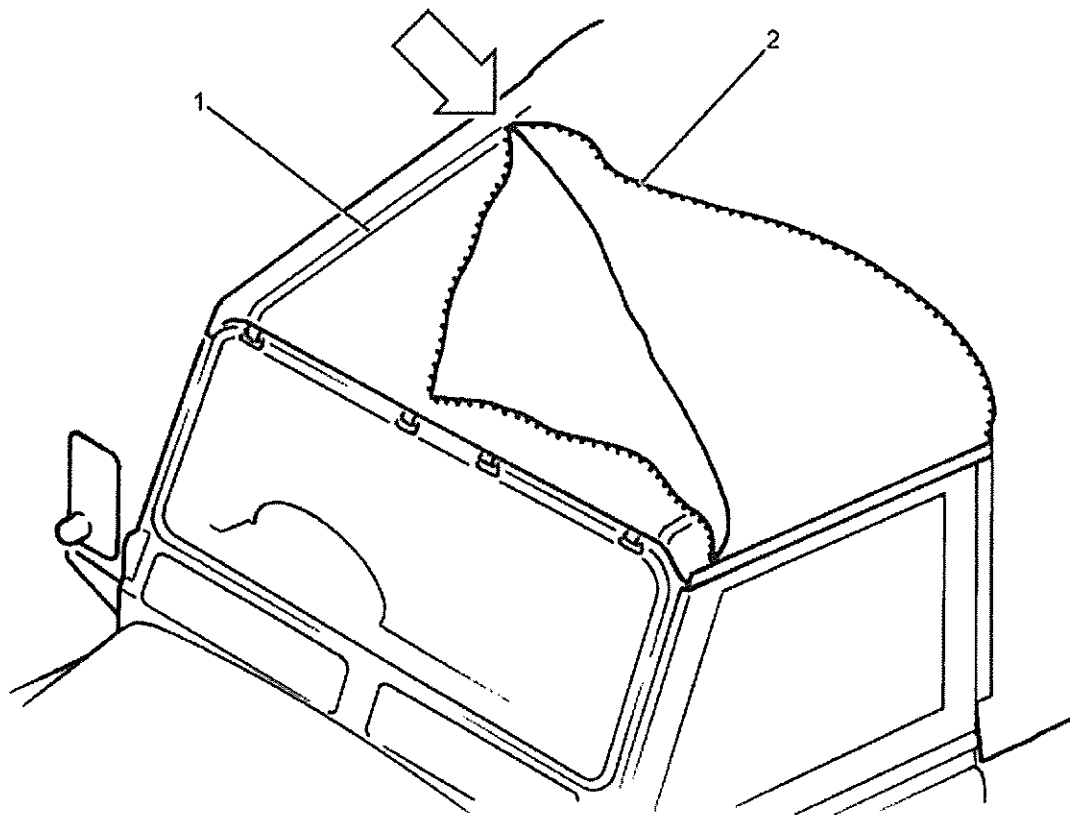

1 Hood joint 2 Zip

Fig 34 Soft top hood

- 64.4 Hook one end of the elastic cord (item 19) onto the driver's side sun visor mount. Loop the strap around the hood.
- 64.5 Hook the other end onto the breather tube on the air intake pipe (on the driver's side windscreen pillar).
- 64.6 Ensure that any items stowed on the roof do not obstruct free movement through the hatch.

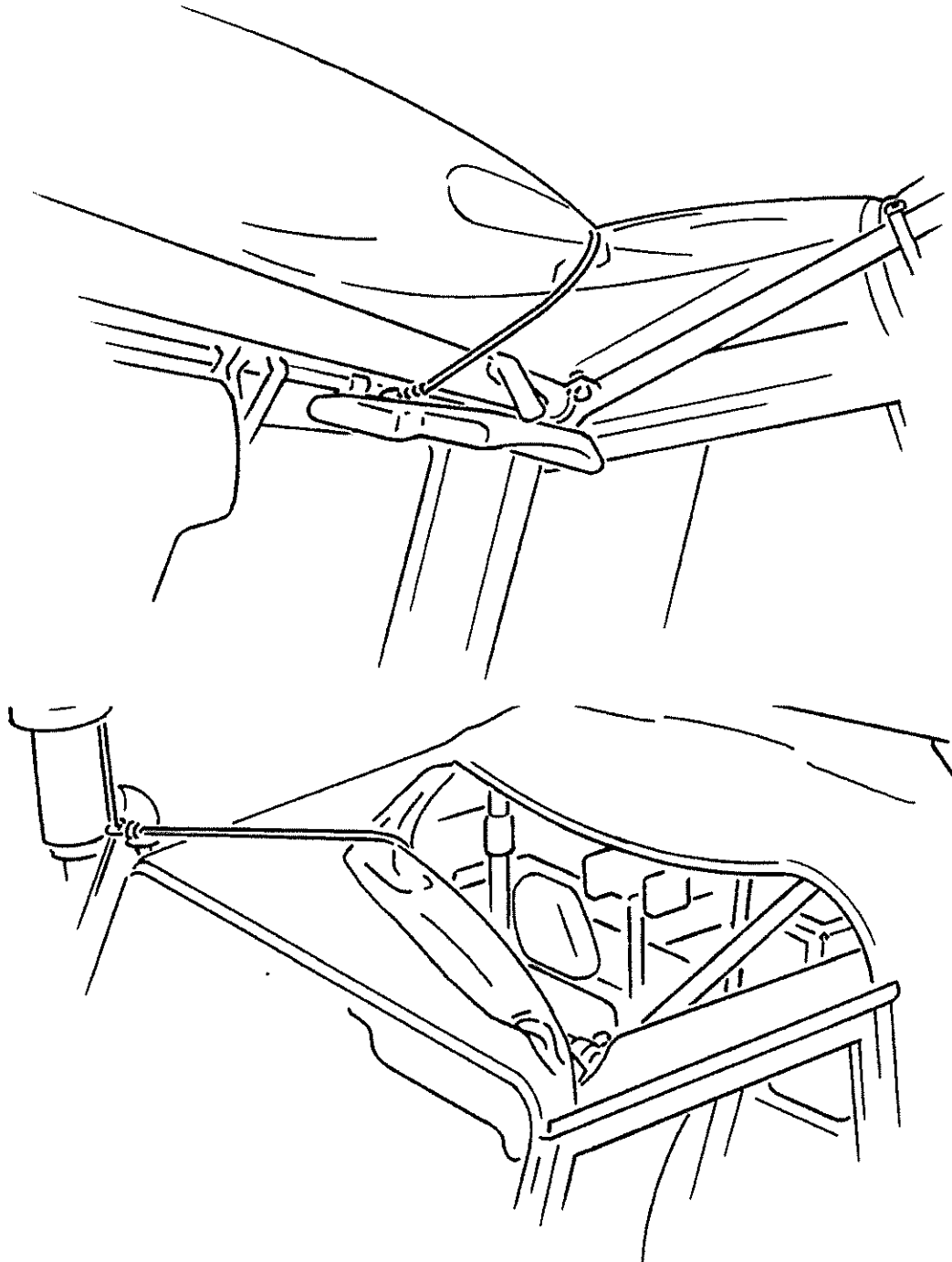

Fig 35 Escape hatch soft top

TASK 28 ESCAPE HATCH – HARD TOP VEHICLE

WARNING

PERSONNEL SAFETY. THE ESCAPE HATCH PROVIDES A MEANS OF ESCAPE FROM THE VEHICLE IN AN EMERGENCY. THE ESCAPE HATCH COVER MUST BE REMOVED FOR ALL FORDING OPERATIONS.

65 Release the cab roof escape hatch securing straps. Remove the cab escape hatch. Using the straps; clamp the hatch to the roof of the vehicle for safe storage.

65.1 Ensure that any items stowed on the roof do not obstruct free movement through the escape hatch.

TASK 29 PRESERVATION

66 Apply an even coat of grease XG-286 (item 35) using brush (item 29) for preservation against salt water immersion to the following:

66.1 Door hinges, door catches and key lock barrels.

66.2 Dashboard ventilator hinges.

66.3 Jerrycan stowage door hinges.

66.4 Wheel nuts.

TASK 30 TAILGATE – SOFT TOP VEHICLE

NOTE

The tailgate is propped open to allow quick flooding of the rear body to limit the amount of vehicle flotation.

67 Prop the tailgate open using two tailgate stays (item 11). Secure stays with pins supplied and original tailgate retaining pins.

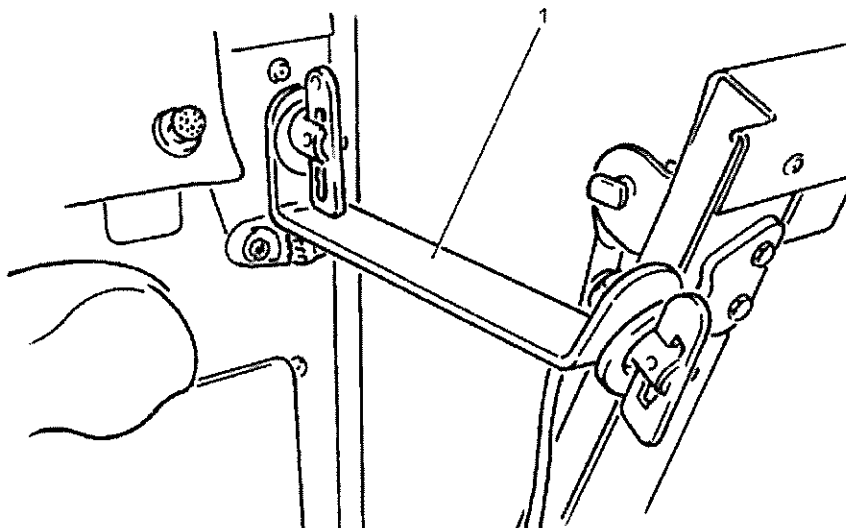

1 Tailgate stay

Fig 36 Tailgate

TASK 31 REAR DOOR HARD TOP VEHICLE

NOTE

The door stay is fitted to allow quick flooding of the rear body to limit the amount of vehicle flotation.

68 Locate the door stay (item 12) into the door striker on the rear body.

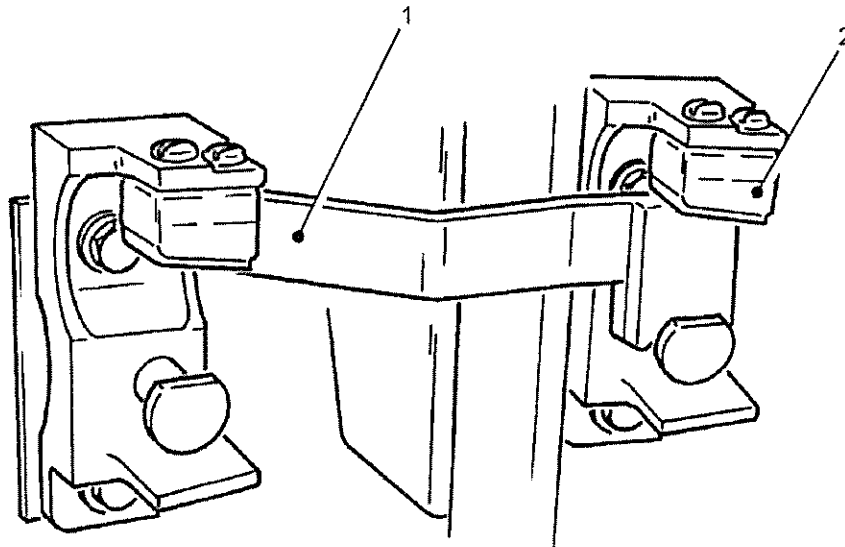

1 Door stay 2 Door striker

Fig 37 Rear door stay

68.1 Align the rear door lock with the door stay and securely close the door onto the stay. Ensure that the latch is fully engaged.

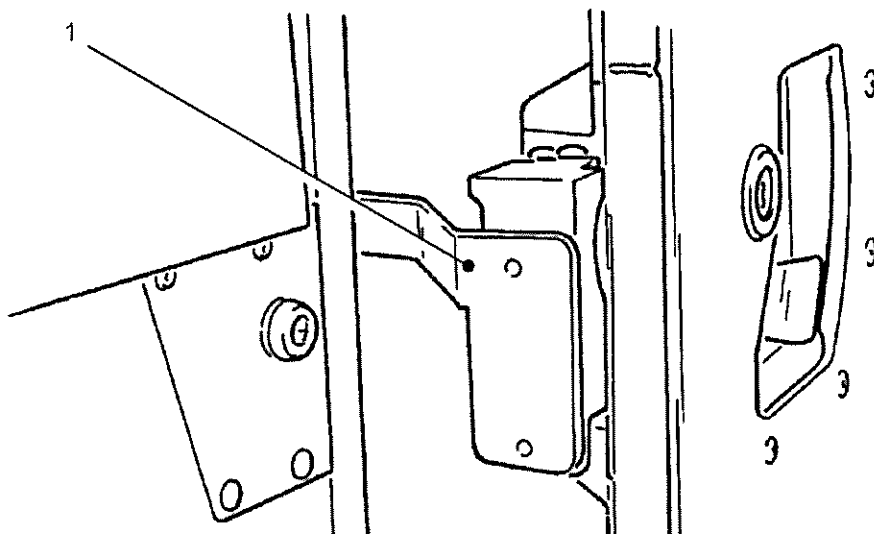

1 Door stay

Fig 38 Rear door

TASK 32 TOWROPE

69 Connect a suitable towrope to the front tow pin. Position the free end of the towrope up over the windscreen and through the escape hatch.

69.1 Tie one end of the rope, fibrous (item 30) to the free end of towrope. Create a suitable large knot at the other end so that it may be used as a throwing line.

TASK 33 FIRE EXTINGUISHER AND ITEMS OF EQUIPMENT

70 Remove fire extinguisher. Place extinguisher, tool roll, jack and other loose items likely to suffer damage caused by sea water immersion in one of the zipped stowage bags (item 23). Close the zip, stow and secure the bag in a safe place on board vehicle.

TASK 34 STAGE 'B' KIT AND REMOVED ITEMS

71 Refill the spray container (item 24) with PX-24 (item 34), ensure the top is tightly secured and place in the stage 'B' kit bag (item 22). It is required for de-waterproofing stages 'C' and 'D'.

71.1 Place all remaining items of the stage 'B' kit in the stage 'B' kit bag (item 22). Place the kit bag and all items removed at stage 'B' waterproofing in a zipped stowage bag (item 23).

TASK 35 WATERPROOFED EQUIPMENT MARKING STAGE 'B'

72 Remove the adhesive tape covering the RED stage 'B' marker on the front of vehicle (see Fig 2).

TASK 36 WATERPROOFING THE AESP

73 Read and memorize Task 37: "Driving instructions for Prepared Forging".

73.1 Place this AESP in the zipped stowage bag (item 23) containing the remainder of the stage 'B' kit. They will be required for de-waterproofing stages 'C' and 'D' and wet-shod re-embarkation should it be necessary.

73.2 Close the zip on the bag. Secure bag in a safe place on board vehicle.

TASK 37 DRIVING INSTRUCTIONS FOR PREPARED FORDING

CAUTIONS

(1) **EQUIPMENT DAMAGE.** If the vehicle stalls with the engine underwater no attempt must be made to restart the engine before Drowned Vehicle Procedure (DVP) is completed.

(2) **EQUIPMENT DAMAGE.** It is essential to keep the vehicle moving through the water as 'loss of momentum' could cause failure. Do not change gear whilst in the water.

74 Engage first gear, low ratio with differential lock.

74.1 Approach ramp squarely and drive vehicle as slowly as possible down ramp. Upon entering water, depress accelerator and drive to the beach.

74.2 In the event of a vehicle failure, the driver must engage neutral gear before any recovery is attempted. Instructions for the recovery of drowned vehicles are contained in AESP 2300-A-600-013 (Waterproofing Regulations Vehicles and Equipment);

74.3 If the failure is due to loss of traction. The driver should keep the engine running during beach recovery, providing the engine air intake is clear of the water.

74.4 If the failure is due to a vehicle stall. No attempt must be made to restart the engine before Drowned Vehicle Procedure (DVP) is completed after beach recovery.

DE-WATERPROOFING STAGE 'C'**CAUTIONS**

- (1) **TIME LIMITATION.** The following Tasks must be conducted within 15 minutes of leaving the water.
- (2) **DEFECT REPORTING.** All defects including occurrences of water ingress found during stage 'C' de-waterproofing, must be reported to a senior member of Unit ES staff as soon as operationally possible, for appropriate Equipment Failure Report (EFR) action.

TASK 38 ENGINE OIL LEVEL CHECK**WARNINGS**

- (1) **PERSONNEL SAFETY. EXTREME CARE MUST BE TAKEN WHEN DRAINING ENGINE OIL. HOT ENGINE OIL CAN CAUSE SEVERE PERSONAL INJURY.**
- (2) **HEALTH HAZARD. PROLONGED AND REPEATED CONTACT WITH USED ENGINE OILS MAY CAUSE SERIOUS SKIN DISORDERS, INCLUDING DERMATITIS AND CANCER.**

CAUTION

OIL LEVEL. Engine must be switched off for ten minutes before any oil level check. The oil level must never be above the 'FULL' mark as engine damage may be caused.

75 Switch 'OFF' the engine and check engine oil level, if contaminated (emulsified), drain and refill with the correct grade oil.

TASK 39 CENTRE CONSOLE

76 Remove the cover retaining strap and the cover from the centre console.

76.1 Remove the tapered silicone plug from the console drain and check for contamination.

76.2 Stow the cover, strap, tapered plug and the ignition switch rubber cover in the stage 'B' kit bag (item 22).

TASK 40 ALTERNATOR RECONNECTION

77 Switch 'OFF' and stop the engine.

77.1 Remove the passenger seat cushion and the battery compartment cover. Disconnect the negative earth cable from the battery.

77.2 Locate the multi-plug disconnect tool attached to the left hand front wing above the windscreen washer reservoir.

77.3 Using the tool depress the multi-plug latch, applying light pressure only, disconnect the two multi-plugs.

77.4 Replace the disconnect tool to its original location.

77.5 Connect the blue multi-plugs together.

77.6 Connect the red multi-plugs together.

77.7 Reconnect battery negative cable. Do not refit battery cover, it will be refitted during the next task.

77.8 Start engine and check that the alternator is functioning correctly.

TASK 41 VEHICLE BATTERIES (2)

WARNINGS

(1) NO SMOKING OR NAKED FLAMES. LEAD ACID BATTERIES PRODUCE POTENTIALLY EXPLOSIVE GASES.

(2) BATTERIES CONTAIN CORROSIVE ACID ELECTROLYTE. WEAR PROTECTIVE GLOVES AND GOGGLES IF ORIGINAL LEAD ACID BATTERIES ARE FITTED. REMOVE AND DISCARD THE RUBBER TUBE FROM THE BATTERY VENTS.

78 If original lead acid batteries are fitted, remove and discard the rubber tube from the battery vents.

78.1 Refit battery compartment cover and seat cushion.

TASK 42 BOWMAN RADIO INSTALLATION

79 Remove any excess water from the radio units and dry off all moisture from the cable connectors. Refit and reconnect the PUDT to the PUDT mounting tray. Refit the HF radio if required. Refit any disconnected cables. Ensure that all cable connections are clean and dry before re-connection.

TASK 43 FUEL TANK BREATHER

80 Depress connector latches and disconnect fuel tank breather pipe from the red colour coded pipe.

80.1 Connect fuel tank breather pipe to the blue colour coded vent pipe.

TASK 44 BRAKE FLUID RESERVOIR

81 Slacken reservoir filler cap. Remove rubber cover, tighten cap.

81.1 Depress latch and remove blanking plug from fluid level sensor multi-plug. Connect multi-plug to the fluid sensor. Stow rubber cover and blanking plug in the stage 'B' kit bag (item 22).

TASK 45 CLUTCH FLUID RESERVOIR

82 Remove rubber cover from clutch fluid reservoir. Stow cover in the stage 'B' kit bag (item 22).

TASK 46 HEATER MOTOR

83 Remove bung from motor drain tube, stow bung in the stage 'B' kit bag (item 22).

83.1 De-latch the multi-plugs and connect the grey multi-plugs together.

83.2 Connect the orange multi-plugs together.

TASK 47 FLYWHEEL HOUSING

84 Remove flywheel housing drain plug and check for contamination. Stow plug in the stage 'B' kit bag (item 22).

TASK 48 FRONT SEAT BELTS**WARNING**

PERSONNEL SAFETY. THE SEAT BELTS MUST BE REFITTED AT STAGE 'C' DEWATERPROOFING TO MEET ROAD TRAFFIC REGULATIONS.

NOTE

This task to be carried out with the assistance of a vehicle mechanic.

85 Refit seat belts using new patch lock bolts. Tighten inertia reel securing nuts to the correct torque setting (15 Nm) using the torque wrench (item 41). If new bolts not available use existing with Loctite (item 40).

85.1 Tighten the shouldered bolts securing the seat belts to the roll over cage to the correct torque setting (28-35 Nm) using the torque wrench (item 41).

85.2 Tighten the engagement/release stalk securing bolts to the correct torque setting (28-35 Nm) using the torque wrench (item 41).

TASK 49 FRONT SEATS**NOTE**

The covers are supplied to provide a waterproof barrier between the occupants and the seats.

86 Remove the head restraints by carefully lifting from their mounting sockets.

86.1 Fit and secure a cover (item 20) over each of the front seat backrests. Refit the head restraints to the front seats.

86.2 Fit and secure a cover (item 21) over each of the front seat cushions.

TASK 50 REAR DOOR – HARD TOP VEHICLE

87 Remove the rear door stay and stow in the zipped stowage bag (item 23).

TASK 51 TAILGATE – SOFT TOP VEHICLE

88 Remove the tailgate stays and stow in the zipped stowage bag (item 23).

TASK 52 REAR SEAT BELTS**WARNING**

PERSONNEL SAFETY. THE SEAT BELTS MUST BE REFITTED AT STAGE 'C' DEWATERPROOFING TO MEET ROAD TRAFFIC REGULATIONS.

89 Refit the rear static seat belts or, if fitted, AR seat belts using existing bolts and Loctite (item 40) to the correct torque setting (28-35 Nm) using the torque wrench (item 41).

TASK 53 STEERING COLUMN BOX

90 Remove the rubber covers from steering column box. Care must be taken when removing the covers to avoid accidental damage, the covers must be gently rolled off the steering column box. Stow the rubber covers in the stage 'B' kit bag (item 22).

90.1 Withdraw the original switch rubber covers from inside the box apertures. Carefully refit the covers to the steering column box.

TASK 54 FRONT WIPER BOX

91 Remove the tapered plug from the wiper box and check for contamination. Stow the plug in the stage 'B' kit bag (item 22).

TASK 55 REAR WIPER BOX - HARD TOP VEHICLE

92 Remove the tapered plug from the wiper box and check for contamination. Stow the plug in the stage 'B' kit bag (item 22).

TASK 56 HEATER PLUGS

93 Spray PX-24 (item 34) from container (item 24) over each glow plug terminal connection to flush away any sand and salt. Stow container in the zipped stowage bag (item 23).

TASK 57 TOWROPE

94 Remove towrope from vehicle. Remove the rope, fibrous (item 30) throwing line from the towrope. Stow the throwing line in the stage 'B' kit bag (item 22). Stow the towrope in a safe place on board the vehicle.

TASK 58 ESCAPE HATCH – HARD TOP VEHICLE

95 Refit the escape hatch.

TASK 59 ESCAPE HATCH – SOFT TOP VEHICLE

96 Remove bungee strap from the hood by releasing from air intake breather tube and sun visor mount:

96.1 Stow the bungee strap in the stage 'B' kit bag (item 22).

96.2 Unroll the hood and close the zip.

96.3 Refit the lining to the driver's cab and secure with strips and straps.

TASK 60 FIRE EXTINGUISHER

97 Refit the fire extinguisher to the vehicle.

TASK 61 NUMBER PLATE LAMP

98 Remove the rubber cover from the number plate lamp and stow in the stage 'B' kit bag (item 22).

TASK 62 WATERPROOFED EQUIPMENT MARKING STAGE 'C'

99 Cover the RED stage 'B' marker (see Fig 2) with black adhesive tape (item 26).

TASK 63 TEMPORARY HALT PROCEDURE

100 If a temporary halt procedure is necessary, the following precautions should be actioned:

100.1 Disconnect negative cable from battery.

100.2 Chock road wheels.

100.3 Leave the handbrake in the 'OFF' position.

WET SHOD RE-EMBARKATION**CAUTION**

EQUIPMENT DAMAGE. Following completion of wet shod re-embarkation, de-waterproofing stages 'C' and 'D' must be carried out in accordance with this AESP.

SUMMARY

101 This instruction details action to be taken when the vehicle will wet shod re-embark on the landing craft after disembarking operations have been completed.

101.1 Check all oils for water contamination as detailed in de-waterproofing stage 'D'.

101.2 Carry out a thorough check of all tasks completed in waterproofing stage 'B' and rectify any damage.

101.3 Top up vehicle fuel tank. Refit filler cap.

101.4 Remove the front seat covers (items 20 and 21) and stow in the stowage bag (item 23).

101.5 Carry out tasks 1, 2, 3, 4, 5, 6, 7, 8, 10, 11, 14, 15, 16, 17, 18, 19, 21, 22, 23, 24, 25, 26, 27, 28, 30, 31, 32, 33, 34, 35, 36 and 37.

DE-WATERPROOFING STAGE 'D'

CAUTIONS

- (1) **MILEAGE LIMITATION AFTER DISEMBARKATION.** Tasks 64, 65, 66 and 67 must be carried out after 25 miles (40 km) or 12 hours (whichever comes first), from point of disembarkation if operationally possible. The remaining tasks should be carried out as soon as conditions permit but within 250 miles (400 km) or 3 days (whichever occurs first), of landing.
- (2) **WASH DOWN.** The alternator must be washed down with fresh water after Prepared Fording within three to four hours.
- (3) **DEFECT REPORTING.** All defects including occurrences of water ingress found during stage 'D' de-waterproofing, must be reported to a senior member of Unit ES staff as soon as operationally possible, for appropriate Equipment Failure Report (EFR) action.

TASK 64 OIL CONTAMINATION CHECK

WARNINGS

- (1) **PERSONNEL SAFETY. EXTREME CARE MUST BE TAKEN WHEN DRAINING ENGINE OIL. HOT ENGINE OIL CAN CAUSE SEVERE PERSONAL INJURY.**
- (2) **HEALTH HAZARD. PROLONGED AND REPEATED CONTACT WITH USED ENGINE OILS MAY CAUSE SERIOUS SKIN DISORDERS, INCLUDING DERMATITIS AND CANCER.**

CAUTION

OIL LEVEL. Engine must be switched off for ten minutes before any oil level check. The oil level must never be above the 'FULL' mark as engine damage may be caused.

102 Check engine, gearbox and axle oil levels. If water is present (emulsified), in any assembly:

- 102.1 Drain oil.
- 102.2 For engine contamination, remove and discard the oil filter. Fit a new engine oil filter.
- 102.3 Refill all assemblies with the correct grade lubricant.

TASK 65 CLUTCH AND BRAKES

103 To prevent seizure of clutch and brakes when parked, every opportunity should be taken to:

- 103.1 Prop out clutch pedal with a suitable prop.
- 103.2 Chock road wheels and leave the handbrake in the 'OFF' position.

TASK 66 WASH DOWN

WARNING

PERSONNEL SAFETY. THE SEAT BELTS AND FRONT SEAT HEAD RESTRAINTS MUST BE REFITTED FOLLOWING THE WASH DOWN, TO MEET ROAD TRAFFIC REGULATIONS.

CAUTION

EQUIPMENT DAMAGE. Water entering the engine air intake system will cause major failure when the engine is restarted. Do not direct the wash down hose at the high level air intake or allow water to enter the intake system. Avoid prolonged hosing of electrical equipment.

NOTE

This task to be carried out with the assistance of a vehicle mechanic.

104 It is important that the correct wash down procedures is observed.

104.1 The following guidelines must be adhered to when washing down the vehicle to avoid damage to the wax protective coating:

104.1.1 Cold water pressure washing is preferred. In any event, water temperature should not exceed 60 degrees C.

104.1.2 Pressure of water should not exceed 1200 PSI.

104.1.3 Ensure a distance of approximately 30 cm between the nozzle lance and the surface being washed.

104.1.4 No detergent is to be used.

104.2 Remove the passenger seat cushion and the battery compartment cover. Disconnect the negative cable from the battery.

104.3 Carry out stage 'B' waterproofing tasks 2, 4, 5, 11, 14, 15, 16, 17, and 21.

104.4 Remove the fire extinguisher, front seat head restraints, front seat covers (items 20 and 21) and any loose items of equipment from the vehicle, that would be likely to suffer damage during wash down.

104.5 Wash down the entire vehicle thoroughly with freshwater. Remove all traces of sand and salt deposits. Ensure the following areas are included:

104.5.1 Alternator, engine and all under bonnet areas.

104.5.2 Cab and rear cargo body.

104.5.3 Jerry can stowage compartments.

104.5.4 Top of fuel tank and tank filler neck compartment.

104.6 Carry out stage 'C' de-waterproofing tasks 36, 41, 42, 45, 46, 49, 50, 51 and 52.

104.7 Reconnect the negative cable to the battery. Refit battery compartment cover and passenger seat cushion.

104.8 Refit the front seat head restraints, fire extinguisher and loose items of equipment.

TASK 67 ALTERNATOR BREATHER**WARNING**

HEAT INJURY HAZARD. EXHAUST COMPONENTS WILL BECOME VERY HOT WHEN THE ENGINE IS RUNNING. IN ORDER TO PREVENT THE POSSIBILITY OF SEVERE PERSONAL INJURY, ADEQUATE TIME MUST BE ALLOWED FOR THE ENGINE SYSTEM TO COOL BEFORE ANY WORK IS UNDERTAKEN IN THE VICINITY OF THE EXHAUST MANIFOLD.

NOTES

(1) This task to be carried out with the assistance of a vehicle mechanic.

(2) The breather is located on the underside of the alternator end cover. Access is difficult and care must be taken not to damage any of the intercooler pipes.

105 Refit the alternator breather hose and secure with the original wing screw clamp.

TASK 68 WEBASTO HEATER

NOTE

This task to be carried out with the assistance of a vehicle mechanic.

106 Flush the exhaust system through with freshwater. Take care that no other vehicle systems are contaminated with water.

106.1 Remove the caps from the intake and exhaust pipes. Stow the caps and the exhaust cap clamp in the stage 'B' kit bag (item 22).

106.2 Install the connection sleeve and refit the exhaust to the heater. Ensure clearance between the Webasto exhaust and the engine turbocharger.

106.3 Refit the intake pipe to the heater and secure with its original clamp. Ensure the pipe is fitted through its support clip and the open end is facing downward.

106.4 Spray an even coat of PX-24 (item 34) from container (item 24) over the heater to wash off any sand or salt deposits.

106.5 Remove the cap from the Webasto control box drain valve. Depress the valve core and check for water ingress. If water is present, test the control box in accordance with AESP 2320 D 128-522 Chap 13-5.

106.6 Refit the heater switch knob.

106.7 Operate heater for fifteen minutes for drying out purposes and to check that it is functioning correctly.

TASK 69 HEATER CONTROL CABLES

NOTE

This task to be carried out with the assistance of a vehicle mechanic.

107 Referring to AESP 2320-D-128-522 Chap 18, service the three heater control cables.

107.1 Ensure correct operation of all control cables

TASK 70 FRONT SEATS

WARNING

HEALTH HAZARD. BEFORE THE COMMENCEMENT OF ANY PAINTING, REFER TO AESP 0200-A-221-013, 'PAINTING OF SERVICE EQUIPMENT' AND THE RELEVANT COSHH REGULATIONS FOR THE MATERIAL.

NOTES

(1) This task to be carried out with the assistance of a vehicle mechanic.

(2) Do not allow any fluids or oils to contaminate the seat upholstery.

108 Remove front seats and runners. Remove the seat covers (items 20 and 21). Lift off the backrest adjustment lever cover.

108.1 Wash off the seat runners and the backrest adjustment mechanisms with PX-24 (item 34) using spray container (item 24). Remove all traces of sand and salt deposits.

- 108.2 Restore any damaged paint finish to the seats.
- 108.3 Lightly lubricate all seat moving parts with OMD 90 oil.
- 108.4 Refit the backrest adjustment lever covers.
- 108.5 Refit front seats and runners.
- 108.6 Refit the seat covers if required. If the seats have dried sufficiently and the covers are not required, place the covers in the zipped stowage bag (item 23).

TASK 71 DOOR LOCKS AND HINGES

NOTE

This task to be carried out with the assistance of a vehicle mechanic.

109 Remove all door locks. Wash out the lock mechanisms and the key lock barrels with PX-24 (item 34) using the spray container (item 24). Ensure all traces of sand and salt deposits are removed.

- 109.1 Lubricate all moving parts with OMD 90 oil ensuring smooth operation of key lock barrels.
- 109.2 Refit all door locks.
- 109.3 Wash off all hinges including jerrycan stowage and dashboard ventilators with PX-24 (item 34) using the spray container (item 24). Ensure all traces of sand and salt deposits are removed.
- 109.4 Lubricate all hinges with OMD 90 oil.

TASK 72 HUBS AND BRAKES

WARNINGS

(1) HEALTH HAZARD. BEFORE THE COMMENCEMENT OF ANY PAINTING, REFER TO AESP 0200-A-221-013, 'PAINTING OF SERVICE EQUIPMENT' AND THE RELEVANT COSHH REGULATIONS FOR THE MATERIAL.

(2) SAFETY. DO NOT ALLOW ANY PAINT TO CONTAMINATE THE BRAKE LININGS OR THE FRICTION SURFACES OF THE BRAKE DRUM.

NOTE

This task to be carried out with the assistance of a vehicle mechanic.

110 Strip and service all wheel hubs ensuring that the hub oil seals are renewed (refer to AESP 2320-D-128-522 Chap 5 and 6). Wash off stub axles with PX-24 (item 34) using the spray container (item 24) to remove all traces of sand and salt deposits.

- 110.1 Ensure serviceability of brake pads and callipers before reassembly (refer to AESP 2320-D-128-522 Chap 10).
- 110.2 Strip and service the transmission handbrake (refer to AESP 2320-D-128-522 Chap 10). Wash off the oil seal area of the transfer box drive flange with PX-24 (item 34) using the spray container (item 24). Ensure all traces of sand and salt deposits are removed.
- 110.3 Prior to reassembly, paint the following items with red oxide H1 8010-99-910-6645 for protection. Do not contaminate brake linings or friction surface areas of the brake drum with paint.

- 110.3.1 Brake shoes.

110.3.2 Brake back plate.

110.3.3 Brake drum.

110.4 Lubricate the handbrake ratchet pawl linkage with OMD 90 oil.

TASK 73 CLUTCH

111 Lightly lubricate the clutch pedal linkage with OMD 90 oil.

TASK 74 STOWAGE COMPARTMENTS

WARNING

HEALTH HAZARD. BEFORE THE COMMENCEMENT OF ANY PAINTING, REFER TO AESP 0200-A-221-013, 'PAINTING OF SERVICE EQUIPMENT' AND THE RELEVANT COSHH REGULATIONS FOR THE MATERIAL.

112 Remove all traces of sand and salt deposits from the jerrycan stowage compartment.

112.1 Remove all traces of sand and salt deposits from the stowage compartment located under the front seat on the TUM variant.

112.2 Restore any damaged paint finish to the jerrycan and under seat stowage compartments.

TASK 75 VEHICLE BATTERY COMPARTMENT

WARNINGS

(1) NO SMOKING OR NAKED FLAMES. LEAD ACID BATTERIES PRODUCE POTENTIALLY EXPLOSIVE GASES.

(2) BATTERIES CONTAIN CORROSIVE ACID ELECTROLYTE. WEAR PROTECTIVE GLOVES AND GOGGLES WHEN HANDLING BATTERIES.

(3) HEALTH HAZARD. BEFORE THE COMMENCEMENT OF ANY PAINTING, REFER TO AESP 0200-A-221-013, 'PAINTING OF SERVICE EQUIPMENT' AND THE RELEVANT COSHH REGULATIONS FOR THE MATERIAL.

NOTE

This task to be carried out with the assistance of a vehicle mechanic.

113 Remove passenger seat cushion and the battery compartment cover. Disconnect and remove the batteries. Undo the fixings and remove the battery trays.

113.1 Remove all traces of sand and salt deposits from the battery compartment and the battery trays. Allow the compartment to completely dry out.

113.2 Restore any damaged paint finish to the battery compartment and the battery trays.

113.3 Refit the battery trays.

113.4 Clean the battery casings. Refit and reconnect the batteries. Apply a coat of PX-7 grease (item 36) to the terminals.

113.5 Refit battery compartment cover and the seat cushion.

113.6 From under the vehicle apply a coat of 'Dinol' wax to the battery tray fixings to preserve the underbody wax protection (refer to AESP 2320-D-128-522 Chapter 16).

TASK 76 FLOOR COVERINGS**WARNING**

HEALTH HAZARD. BEFORE THE COMMENCEMENT OF ANY PAINTING, REFER TO AESP 0200-A-221-013, 'PAINTING OF SERVICE EQUIPMENT' AND THE RELEVANT COSHH REGULATIONS FOR THE MATERIAL.

114 Remove the floor mats from the driver's cab and the rear cargo body. From inside the rear body, remove the heater pipe protection cover attached to the rear bulkhead.

114.1 Remove all traces of sand and salt deposits from the cab and rear cargo body areas. Allow the floors to completely dry out.

114.2 Restore any damaged paint finish to the driver's and rear cargo body.

114.3 Wash off the floor mats with freshwater and allow to dry out.

114.4 Refit the heater pipe protection cover to the rear bulkhead.

114.5 Refit the floor mats.

TASK 77 NATO 12 PIN TOWING SOCKET

115 Remove all traces of silicone compound from the towing socket.

TASK 78 DELETED

116 Deleted.

TASK 79 COMPONENT BREATHER SYSTEM DRAIN**NOTES**

(1) This task to be carried out with the assistance of a vehicle mechanic

(2) The drain tube is located under at the rear of the right hand front wheel arch, above the chassis outrigger. Access is gained from beneath the right hand front wing.

117 Release the hose clamp, remove the plug and drain off any contamination. Refit the plug and tighten the clamp.

117.1 If contamination is more than could be expected from condensation, the cause must be investigated and rectified.

TASK 80 REAR VIEW MIRRORS – DOOR MOUNTED

118 Prise the plastic caps from the mirror head adjustment. Wash off the adjustment screws and washer with PX-24 (item 34) using the spray container (item 24). Refit the plastic caps.

TASK 81 FRONT AND REAR LIGHTS

119 Examine front and rear lights for contamination. If contamination is present in any light:

119.1 Remove and drain light.

119.2 Wash out light in freshwater and dry off thoroughly.

119.3 Refit light (refer to AESP 2320-D-128-201 Chap 4-1).

TASK 82 GEAR LEVER HOUSING

NOTES

- (1) This task to be carried out with the assistance of a vehicle mechanic.
- (2) It will be necessary to demand the replacement parts required for this task.

120 Remove gear lever housing and check for contamination. Remove any traces of contamination from the lever housing and the remote housing.

120.1 Refit lever housing (refer to AESP 2320-D-128-523) using the following replacement parts:

- 120.1.1 Gear lever grommet.
- 120.1.2 Grommet cable tie.
- 120.1.3 Housing gasket.

TASK 83 TRANSFER GEARBOX SELECTOR HOUSING

NOTES

- (1) This task to be carried out with the assistance of a vehicle mechanic.
- (2) It will be necessary to demand the replacement parts required for this task.

121 Remove transfer gearbox lever grommet and check housing for contamination. Remove any traces of contamination from the housing.

121.1 Renew the transfer lever grommet (refer to AESP 2320-D-128-523) and assemble using the following replacement parts:

- 121.1.1 Grommet cable tie.
- 121.1.2 Grommet support plate.
- 121.1.3 Gasket.

TASK 84 PROPELLER SHAFTS

122 Grease gun lubricate all propeller shaft joints to expel any sea water (refer to AESP 2320-D-128-01, Table 7).

TASK 85 LUBRICATION AND MAINTENANCE

NOTE

This task to be carried out with the assistance of a vehicle mechanic.

123 Complete the 6000 miles (10000 km) maintenance schedule (refer to AESP 2320-D-128-601, Table 7).

TASK 86 ENGINE CONTROLS

NOTE

This task to be carried out with the assistance of a vehicle mechanic.

124 Lubricate the engine controls with OMD 90 oil and ensure correct operation.

TASK 87 REAR TOW PINTLE

NOTE

This task to be carried out with the assistance of a vehicle mechanic.

125 Service and ensure correct operation of the tow pintle (refer to AESP 2320-D-128-601, Table 7).

TASK 88 FRONT SEAT BELTS

WARNING

PROCEDURE. TO MAINTAIN THE INTEGRITY OF SEAT BELT TORQUE SETTING, THE SECURING BOLTS MUST BE REPLACED AT STAGE 'D' DE-WATERPROOFING.

NOTE

This task to be carried out with the assistance of a vehicle mechanic.

126 Remove and discard the two bolts securing the seat belts to the roll over cage. Refit the seat belts using the two shouldered patchlock bolts supplied in the seat belt fixing kit (item 39). Tighten the bolts to the correct torque setting (28-35 NM) using the torque wrench (item 41).

126.1 Remove and discard the two bolts securing the seat belt anchorage/release stalks to the body. Refit the stalks using the two bolts and two lock washers supplied in the seat belt fixing kit (item 39). Tighten the bolts to the correct torque setting (28-35 Nm) using the torque wrench (item 41).

126.2 Remove and discard the nuts and washers securing the two inertia reel units to the floor. Refit the inertia reel units using the nuts and washers supplied in the seat belt fixing kit (item 39). Tighten the nuts to the correct torque setting (15 NM) using the torque wrench (item 41).

TASK 89 FUTURE WATERPROOFING REQUIREMENTS

127 This Land Rover waterproofing kit is designed to be re-usable and is classed as **SEMI-PERMANENT** for this reason. Examine the content and condition of the stage 'B' waterproofing kit removed from the vehicle. Re-demand replacement items, detailed in Parts List at Sub Para 11.1, as necessary for future waterproofing use.

TABLE 2 WATERPROOFING TASK CHECK LIST TRUCK UTILITY LIGHT (HS) GS AND TRUCK UTILITY MEDIUM (HS) GS

VEHICLE NO.

Page No. (1)	Para No. (2)	Item (3)	Initialed Completed (4)
15	-	WATERPROOFING STAGE 'B'	
15	37	Sequence of operations	
15	38	Task 1 Vehicle batteries	
16	39	Task 2 Engine air cleaner	
17	40	Task 3 Alternator	
19	41	Task 4 Clutch fluid reservoir	
20	42	Task 5 Brake fluid reservoir	
21	43	Task 6 Heater plugs	
21	44	Task 7 Windscreen washer reservoir	
22	45	Task 8 Fuel tank breather	
23	46	Task 9 Webasto heater	
25	47	Task 10 Heater	
26	48	Task 11 Steering column switches	
26	49	Deleted	
27	50	Task 13 Inter-vehicle start socket	
27	51	Task 14 Front wiper motor box	
28	52	Task 15 Front seat belts	
28	53	Task 16 Rear seat belts	
28	54	Task 17 Rear wiper motor box – hard top vehicle only	
29	55	Task 18 Flywheel housing	
29	56	Task 19 Number plate lamp	
30	57	Task 20 NATO 12 pin towing socket	
31	58	Task 21 Centre console	
34	59	Task 22 Batteries (2)	
35	60	Task 23 Bowman HF Radio & Personal User Data Terminal (PUDT)	
36	61	Task 24 Direct Current Charging Unit (DCCU)	
37	62	Task 25 Radio Selector Box (RSB)	
38	63	Task 26 Radio batteries and Stillage trays	
39	64	Task 27 Escape hatch – soft top vehicle	
41	65	Task 28 Escape hatch – hard top vehicle	
41	66	Task 29 Preservation	
41	67	Task 30 Tailgate – soft top vehicle	
42	68	Task 31 Rear door – hard top vehicle	
43	69	Task 32 Towrope	
43	70	Task 33 Fire extinguisher and items of equipment	

(continued)

TABLE 2 WATERPROOFING TASK CHECK LIST TRUCK UTILITY LIGHT (HS) GS AND TRUCK UTILITY MEDIUM (HS) GS (continued)

VEHICLE NO.

Page No. (1)	Para No. (2)	Item (3)	Initialed Completed (4)
15		WATERPROOFING STAGE 'B' (continued)	
43	71	Task 34 Stage 'B' kit and removed items	
43	72	Task 35 Waterproofed equipment marking stage 'B'	
43	73	Task 36 Waterproofing the AESP	
43	74	Task 37 Driving instructions for 'Prepared Fording'	
44	-	DE-WATERPROOFING STAGE 'C'	
44	75	Task 38 Engine oil level check	
44	76	Task 39 Centre console	
44	77	Task 40 Alternator reconnection	
45	78	Task 41 Vehicle batteries (2)	
45	79	Task 42 BOWMAN radio installation	
45	80	Task 43 Fuel tank breather	
45	81	Task 44 Brake fluid reservoir	
45	82	Task 45 Clutch fluid reservoir	
45	83	Task 46 Heater motor	
45	84	Task 47 Flywheel housing	
46	85	Task 48 Front seat belts	
46	86	Task 49 Front seats	
46	87	Task 50 Rear door – hard top vehicle	
46	88	Task 51 Tailgate – soft top vehicle	
46	89	Task 52 Rear seat belts	
46	90	Task 53 Steering column box	
47	91	Task 54 Front wiper box	
47	92	Task 55 Rear wiper box – hard top vehicle	
47	93	Task 56 Heater plugs	
47	94	Task 57 Towrope	
47	95	Task 58 Escape hatch – hard top vehicle	
47	96	Task 59 Escape hatch – soft top vehicle	
47	97	Task 60 Fire extinguisher	
47	98	Task 61 Number plate lamp	
47	99	Task 62 Waterproofed equipment marking stage 'C'	
47	100	Task 63 Temporary halt procedure	

(continued)

TABLE 2 WATERPROOFING TASK CHECK LIST TRUCK UTILITY LIGHT (HS) GS AND TRUCK UTILITY MEDIUM (HS) GS (continued)

VEHICLE NO.

Page No. (1)	Para No. (2)	Item (3)	Initialed Completed (4)
48	-	WET SHOD RE-EMBARKATION	
48	101	Summary	
49		DE-WATERPROOFING STAGE 'D'	
49	102	Task 64 Oil contamination check	
49	103	Task 65 Clutch and brakes	
50	104	Task 66 Wash down	
51	105	Task 67 Alternator breather	
51	106	Task 68 Webasto heater	
51	107	Task 69 Heater control cables	
51	108	Task 70 Front seats	
52	109	Task 71 Door locks and hinges	
52	110	Task 72 Hubs and brakes	
53	111	Task 73 Clutch	
53	112	Task 74 Stowage compartments	
53	113	Task 75 Vehicle battery compartment	
54	114	Task 76 Floor coverings	
54	115	Task 77 NATO 12 pin towing socket	
54	116	Deleted	
54	117	Task 79 Component breather system drain	
54	118	Task 80 Rear view mirrors – door mounted	
54	119	Task 81 Front and rear lights	
55	120	Task 82 Gear lever housing	
55	121	Task 83 Transfer gearbox selector housing	
55	122	Task 84 Propeller shafts	
55	123	Task 85 Lubrication and maintenance	
55	124	Task 86 Engine controls	
56	125	Task 87 Rear tow pintle	
56	126	Task 88 Front seat belts	
56	127	Task 89 Future waterproofing requirements	

PAGE LEFT INTENTIONALLY BLANK

TRUCK UTILITY LIGHT (TUL) HS FFR HT (WATERPROOFED VARIANTS ONLY)

TRUCK UTILITY MEDIUM (TUM) HS FFR HT (WATERPROOFED VARIANTS ONLY)

CODE NB 4226 3100 CODE NB 5021 3100

PREPARATION FOR SPECIAL ENVIRONMENT INSTRUCTION NO. 2

WATERPROOFING INSTRUCTIONS FFR VARIANTS

Sponsor: OSVP IPT
Project number:
File ref: SUV/8/25/1B
Publication agency: OSVP PT, DE&S Abbey Wood

AMENDMENT RECORD

Amdt No.	Incorporated By (Signature)	Date
1	Incorporated	May 18
2		
3		

Amdt No.	Incorporated By (Signature)	Date
4		
5		
6		

SUBJECT: Waterproofing instructions Stage 'B'

CONTENTS

Para

- 1 Introduction (CAUTIONS)
- 3 Waterproofing stage 'B'
- 4 De-waterproofing stage 'C'
- 5 De-waterproofing stage 'D'
- 6 Associated publications
- 7 Stores required
- 11 Stores, tools and equipment (WARNING)
- 12 General instructions
- 18 Materials, uses and application (WARNING)
- 27 Waterproofing arrangements
- 28 Checking the waterproofing kit
- 29 Waterproofing of cargo
- 31 Preparatory servicing (CAUTIONS)
- 32 Prestik P5408 application
- 35 Waterproofed equipment markings
- 36 Component Location
- WATERPROOFING STAGE 'B'(CAUTION)
- 37 Sequence of operations
- 38 Task 1 Vehicle batteries (WARNINGS)
- 39 Task 2 Radio batteries (4) (WARNINGS)

(continued)

CONTENTS (continued)

Para

- 40 Task 3 Engine air cleaner (CAUTION)
- 41 Task 4 Alternator (upper mounted) (CAUTION)
- 42 Task 5 Alternator (lower mounted) (CAUTION)
- 43 Task 6 Clutch fluid reservoir
- 44 Task 7 Brake fluid reservoir (WARNING) (CAUTION)
- 45 Task 8 Heater plugs
- 46 Task 9 Windscreen washer reservoir (WARNING) (CAUTION)
- 47 Task 10 Fuel tank breather
- 48 Task 11 Webasto heater
- 49 Task 12 Heater
- 50 Task 13 Steering column switches
- 51 Task 14 Deleted
- 52 Task 15 Inter-vehicle start socket
- 53 Task 16 Front wiper motor
- 54 Task 17 Front seat belts
- 55 Task 18 Rear seat belts
- 56 Task 19 Rear wiper motor
- 57 Task 20 Flywheel housing
- 58 Task 21 Number plate lamps
- 59 Task 22 NATO 12 pin towing socket
- 60 Task 23 Centre console (CAUTIONS)
- 61 Task 24 Batteries (2) (WARNINGS)
- 62 Task 25 TUL FFR Bowman radio bag
- 63 Task 26 TUM FFR Bowman radio bag
- 64 Task 27 Radio batteries (4) (WARNINGS)
- 65 Task 28 Escape hatch (WARNING)
- 66 Task 29 Preservation
- 67 Task 30 Rear door
- 68 Task 31 Towrope
- 69 Task 32 Fire extinguisher and items of equipment
- 70 Task 33 Stage 'B' kit and removed items
- 71 Task 34 Waterproofed equipment marking stage 'B'
- 72 Task 35 Waterproofing the AESP
- 73 Task 36 Driving instructions for prepared fording (CAUTIONS)
DE-WATERPROOFING STAGE 'C' (CAUTIONS)
- 74 Task 37 Engine oil level check (WARNINGS) (CAUTION)
- 75 Task 38 Centre console
- 76 Task 39 Rear door
- 77 Task 40 Alternator (upper mounted) reconnection (CAUTION)
- 78 Task 41 Alternator (lower mounted) reconnection
- 79 Task 42 Vehicle batteries (2) (WARNINGS)
- 80 Task 43 Fuel tank breather
- 81 Task 44 Brake fluid reservoir
- 82 Task 45 Clutch fluid reservoir
- 83 Task 46 Heater motor
- 84 Task 47 Flywheel housing
- 85 Task 48 Front seat belts (WARNING)
- 86 Task 49 Front seats
- 87 Task 50 Rear seat belts (WARNING)
- 88 Task 51 Steering column box
- 89 Task 52 Front wiper
- 90 Task 53 Rear wiper
- 91 Task 54 Heater plugs
- 92 Task 55 Towrope
- 93 Task 56 Escape hatch

(continued)

CONTENTS (continued)

Para

94	Task 57 Fire extinguisher
95	Task 58 Number plate lamp
96	Task 59 Radio battery breathers
97	Task 60 Bowman radio bag and equipment
98	Task 61 Waterproofed equipment marking stage 'C'
99	Task 62 Temporary halt procedure
	WET SHOD RE-EMBARKATION (CAUTION)
100	SUMMARY
	DE-WATERPROOFING STAGE 'D' (CAUTIONS)
101	Task 63 Oil contamination check (WARNINGS) (CAUTION)
102	Task 64 Clutch and brakes
103	Task 65 Wash down (WARNING), (CAUTION)
104	Task 66 Lower mounted alternator breather (WARNING)
105	Task 67 Webasto heater
106	Task 68 Heater control cables
107	Task 69 Front seats (WARNING)
108	Task 70 Door locks and hinges
109	Task 71 Hubs and brakes (WARNINGS)
110	Task 72 Clutch
111	Task 73 Stowage compartments (WARNING)
112	Task 74 Vehicle battery compartment (WARNINGS)
113	Task 75 Radio battery compartment (WARNINGS)
114	Task 76 Floor coverings (WARNING)
115	Task 77 NATO 12 pin towing socket
116	Task 78 Deleted
117	Task 79 Component breather system drain
118	Task 80 Rear view mirrors-door mounted
119	Task 81 Front and rear lights
120	Task 82 Gear lever housing
121	Task 83 Transfer gearbox selector housing
123	Task 84 Propeller shafts
124	Task 85 Lubrication and maintenance
125	Task 86 Engine controls
126	Task 87 Rear tow pintle
127	Task 88 Front seat belts (WARNING)
127	Task 89 Future waterproofing requirements

Table

Page

1	Man hour content	6
2	Waterproofing task check list	63

Fig

Page

1	Deleted	11
2	Waterproofed equipment markings	13
3	Component layout	14
4	Air cleaner	16
5	Upper alternator disconnection	17
6	Terminal box	18
7	Charging ECU connections. Forging conditions	19
8	Lower alternator disconnection	20

(continued)

CONTENTS (continued)

Fig		Page
9	Alternator breather	21
10	Clutch fluid reservoir.....	21
11	Fluid level sensor	22
12	Brake fluid reservoir	23
13	Heater plugs	24
14	Fuel tank breather	25
15	Webasto heater	26
16	Webasto caps.....	27
17	Webasto switch	27
18	Heater multi-plugs	28
19	Motor drain	28
20	Steering column switches.....	29
21	Deleted	29
22	Inter-vehicle start socket	30
23	Front wiper box.....	30
24	Rear wiper box	31
25	Flywheel housing.....	32
26	Number plate lamp	32
27	Towing socket terminals.....	33
28	Console cover	34
29	Centre console	35
30	Console drain	36
31	Map lamp.....	36
32	Batteries	37
33	PUDT removal.....	38
34	RSB removal	38
35	BPF cable disconnect.....	39
36	AAC earth cable disconnect.....	39
37	PUDT and external keyboard.....	40
38	GPS Radio receiver.....	40
39	User Control Device	41
40	Antenna cables.....	41
41	Loudspeaker.....	42
42	Radio batteries	43
43	Battery breathers.....	44
44	Rear body	45
45	Rear door	45
46	Charging ECU connections. Normal conditions.....	48

INTRODUCTION

CAUTIONS

(1) **EQUIPMENT DAMAGE.** Only waterproofed variants with the Equipment Asset Code (EAC) listed on page 1 are to be implemented with this instruction. The vehicle must not be subjected to Prepared Fording until the stage 'B' kit is fitted as instructed in this AESP.

(2) **VEHICLE RECORD BOOK.** This instruction AESP 2320-D-128-421 must be retained with the vehicle record book.

1 This instruction details the method of waterproofing to enable the vehicle to be capable of Prepared Fording through an effective depth of 1.5 metres including ramp angle, wheel sink and wave height. The waterproofing when applied will enable the vehicle to ford with the minimum of preparation for six minutes. To enable the vehicle to achieve this objective, a Special Environment Waterproofing kit is fitted.

2 Where variations from standard occur on the vehicle or equipment due to modifications or contract changes, advice and direction of the unit Motor Transport Officer (MTO) should be sought regarding additional or amended tasks.

Waterproofing stage 'B'

3 The modification kit NSN 7XDW 2540 99 573 6346 is fitted prior to Prepared Fording. The maximum time allowed to complete this stage is two hours. This will permit the vehicle to disembark or embark wetshod dependent upon operational requirements. On completion of this stage pre-ford running time should be restricted to 15 minutes. Post ford mileage must conform to stages 'C' and 'D'.

De-waterproofing stage 'C'

4 The tasks in this stage can be completed in a few minutes and must be conducted within 15 minutes of leaving the water.

De-waterproofing stage 'D'

5 Tasks in this stage are dependent on operational conditions. Certain tasks may need to be carried out within 25 miles (40 Km) or 12 hrs from the point of disembarkation. The remaining tasks should be carried out as soon as conditions permit but within 250 miles (400 Km) or 3 days of landing.

NOTES

(1) Vehicle mechanic assistance will be required for Tasks 3, 4, 5, 11, 17, 48, 65, 66, 67, 68, 69, 70, 71, 74, 79, 82, 83, 85, 86, 87 and 88.

(2) Radio operator assistance will be required for Tasks 2, 25, 26, 27, 60 and 75.

Associated publications

6 Refer to Army Equipment Support Publication (AESP):

6.1 2320-D-128-201 Operating Information

6.2 2320-D-128-522 Maintenance Instructions

6.3 2320-D-128-523 Repair Instructions

6.4 2320-D-128-601 Maintenance Schedules

6.5 2300-A-600-013 Waterproofing Regulations - Vehicles and Equipment

STORES REQUIRED

7 Items for waterproofing kits are MOD controlled stores. Operationally they are issued without demand. Should issue be authorized for training purposes:

7.1 In the UK they are to be demanded from the Defence Storage and Distribution Agency (DSDA), Bicester, through district headquarters.

7.2 Overseas, they are to be demanded through formation or district headquarters.

8 When a complete stage 'B' kit is required, the full Army designation of the vehicle or equipment, including code number and contract number is to be stated on the demand. Authority for issue must be quoted.

9 Normally, individual items are not issued separately but may be demanded to make good kit deficiencies. Such demands are to quote full part numbers and designations as shown in this waterproofing instruction para 11.1. A brief explanation of circumstances necessitating the demand is to be attached.

10 Inflammable items which have a shelf storage life are listed at para 11.2 of the kit list. These items are to be demanded separately by units prior to undertaking the fitting of waterproofing kits.

TABLE 1 MAN HOUR CONTENT

Serial (1)	Detail (2)	Approximate time in man-hours			Maximum No. of men who can be usefully employed (6)	Maximum time required in hours (7)
		Crew Drv (3)	Veh Mech (4)	Radio Op (5)		
1	Perusal of this AESP and checking of the Waterproofing kit against the kit list.	2	-	-	2	1
2	Servicing of equipment.	5	1	-	2	5
3	Waterproofing Stage 'B'.	1.5	0.3	0.5	3	1.5
4	De-waterproofing Stage 'C'.	0.5	0.5	0.25	3	0.25
5	Wet shod re-embarkation.	0.5	0.3	0.5	3	0.5
6	De-waterproofing Stage 'D'.	5	7	1	3	13

STORES, TOOLS AND EQUIPMENT

WARNING

HEALTH AND SAFETY. MATERIALS USED IN WATERPROOFING ARE REQUIRED TO MEET OBLIGATIONS INTRODUCED UNDER THE CONTROL OF SUBSTANCES HAZARDOUS TO HEALTH REGULATIONS 2004 (COSHH). SAFETY INFORMATION RELATING TO MATERIALS USED IS CONTAINED IN JSP (F) 395 - CATALOGUE OF HAZARDOUS STORES.

11 Stores to be demanded.

11.1 The following modification items are to be demanded quoting this instruction as authority for demand:

Item No. (1)	DMC (2)	NSN/Part No. (3)	Designation (4)	Qty per Veh (5)
	7XDW	2540-99-573-6346	Special environment waterproofing kit (WPG9735B) Truck Utility Light (HS) FFR HT and Truck Utility Medium (HS) FFR HT (STC 4443) consisting :-	
1	AESP	2320-D-128-421	Waterproofing instruction No. 2 (VDX 100860)	(1)
2	7XDW	5340-99-573-6317	Cover, centre console (IPK 100020)	(1)
3	7XDW	5340-99-928-8246	Strap-console cover (IPM100080)	(1)
4	7XDW	2530-99-573-6323	Cover, brake fluid reservoir (IPK 100090)	(2)*
5	7XDW	2520-99-573-6326	Cover, clutch fluid reservoir (IPK 100120)	(3)*
6	7XDW	2530-99-573-6442	Cover, steering column box (QRS 100010)	(4)*
7	7XDW	5340-99-573-6328	Cap, Webasto intake (IPK 100140)	(2)*
8	7XDW	5340-99-573-6327	Cap, Webasto exhaust (IPK 100130)	(2)*
9	6MT1	4730-99-533-2966	Clamp, Webasto (CN100508L)	(1)
10	7XDW	6240-99-573-6467	Cover, map lamp (XDL 100030)	(1)
11	7XDW	5410-99-573-6530	Stay, rear door (BHF 710020)	(1)
12	7XDW	5340-99-573-6445	Cap, protective (RRC 5110)	(6)
13	7XDW	5325-99-573-6334	Blanking plug, brake harness (IPS100010)	(1)
14			Deleted	
15	7XRU	5365-99-732-7008	Plug, flywheel housing (ERC 7295)	(1)
16	7XDW	5340-99-655-4665	Plug silicone bonding (IPS 100040)	(4)*
17	7XDW	6220-99-845-0035	Cover, number plate lamp (XFK100310)	(2)*
18			Deleted	
19	7XDW	2540-99-937-6287	Seat cover, squab (HBA 106790)	(2)
20	7XDW	2540-99-572-5723	Seat cover, cushion (HCA 106410)	(2)
21	7XDW	2540-99-573-6335	Bag, stage 'B' kit (IPT 100010)	(1)
22	7XDW	2540-99-573-6336	Bag, zipped stowage (IPT 100050)	(4)
23	7XDW	6150-99-573-6510	Harness, grounding (YMS 100140)	(1)
24	H10	7930-99-244-6936	Container, spray (IRE 100000)	(1)
25	6WPG	5970-99-664-8764	Tape, adhesive PVC Scotch 88 (IYN 100000)	(1 roll)
26	H4	8105-99-135-6190	Bag, plastic 450 mm x 255 mm (IPT 100080)	(2)

(continued)

Item No. (1)	DMC (2)	NSN/Part No. (3)	Designation (4)	Qty per Veh (5)
27	F1	8020-99-943-0417	Brush, artist's flat fitch No. 2 (IRX 100000)	(1)
28	F1	8020-99-125-5009	Brush 1 in. wide (IRX 100010)	(1)
29	H21	4020-99-942-5038	Rope, fibrous (IRY 100000)	(10m)
30	Y2	5340-99-933-3089	Cable tie	(20)*

11.2 Stores or suitable equivalent to be obtained locally:

Item No. (1)	DMC (2)	NSN/Part No. (3)	Designation (4)	Qty per Veh (5)
31			Deleted	
32	6WPG	5970-99-225-1703	Compound, silicone 100 g tube	1
33	6WPG	8030-99-062-9759	PX-24 water displacing fluid	1 litre
34	POL	9150-99-224-8885	Grease XG-286, 3 kg tin	150 g
35	POL	9150-99-943-2033	Grease PX-7, 100 g tube	1
36	H1	6850-99-356-7379	Lec Klene solvent cleaner 300 ml	1
37	POL	6850-99-224-5036	AL-11 windscreen washer fluid	A/R
38	POL	6810-99-224-5628	Bag, PVC 36 in. x 24 in. (WPG 8220)	2
39	7XDW	2540-99-627-6986	Seat belt fixing kit (STC 4445)	1 pkt
40	6WPG	1015-99-980-8778	Repair kit for BOWMAN bag	1

11.3 Special tools to be obtained locally:

Item No. (1)	DMC (2)	NSN/Part No. (3)	Designation (4)	Qty per Veh (5)
42	F1	5120-99-812-0439	Torque wrench, 1/2 in. square drive	1

NOTES

- (1) The item numbers of Para 11 are used as reference throughout this instruction.
- (2) (). Denotes item quantities are supplied as part of the overall Special environment waterproofing kit.
- (3) * Denotes a spare is provided to cater for defective or damaged goods.
- (4) ** Denotes item not used.
- (5) Item number of Para 11.3 is required for Vehicle Mechanic (VM) assistance tasks.

GENERAL INSTRUCTIONS

12 The instructions in this publication describe the action to be taken before and after fording, to protect the equipment against damage resulting from immersion in sea water.

13 Waterproofing is carried out in stages and each stage is to be completed in the sequence given in this instruction. The tasks within each stage are shown in the most suitable sequence, but this may be varied according to circumstances. Where complete task coverage requires more than one page, the task should be read in its entirety before commencing a page by page progression.

14 **CLEANLINESS IS THE FIRST ESSENTIAL OF SUCCESSFUL SEALING.** When applying compounds, ensure that the hands are clean and free from grease and that all surfaces to which sealing compounds are to be applied are scrupulously clean. Mud, oil, grease or water will spoil adhesion.

15 **REMEMBER THAT ALL WATERPROOFING MUST BE 100 % SUCCESSFUL.** One carelessly treated component may cause failure at a critical moment, so take great care with every detail. Whenever waterproofing is being carried out during wet weather, suitable shelter should be arranged over the vehicle.

16 The vehicle load must be made secure to prevent any movement whilst the vehicle is ascending or descending the ramp on the ship or Craft.

17 If difficulties are encountered, the Unit MTO should be consulted.

MATERIALS, USES AND APPLICATION

WARNING

HEALTH AND SAFETY. MATERIALS USED IN WATERPROOFING ARE REQUIRED TO MEET OBLIGATIONS INTRODUCED UNDER THE CONTROL OF SUBSTANCES HAZARDOUS TO HEALTH REGULATIONS 2004 (COSHH). SAFETY INFORMATION RELATING TO MATERIALS USED IS CONTAINED IN JSP (F) 395 - CATALOGUE OF HAZARDOUS STORES.

18 Lec Klene solvent cleaner: Used for cleaning and degreasing surfaces before applying any of the various waterproofing materials. Lec Klene is a flammable liquid therefore suitable safety precautions should be taken.

19 Prestik P5408: A plastic sealing compound which, when moulded to joints and apertures prevents water entry. It is also used in some cases to cover electrical components and connections to prevent failure of the electrical system.

19.1 Prestik P5408 is supplied as a strip 24 in. x 1 1/2 in. wide, in a protective wrapping.

19.2 The application of Prestik P5408 is shown in Fig 1. It must not be removed from its wrapping until actually required for application. When handling, the hands must be clean and free from grease. Remove the backing strip as shown in Fig 1. Where a considerable length is called for in a particular task, it is better to apply a series of short lengths, overlapping the strips as shown in Fig 1, and moulding the top layer to the under layer. This allows ease of handling and avoids excessive stretch. It is important that strips of the correct length are used as detailed in this instruction.

NOTE

Always keep Prestik P5408 clean and dry. The biggest hindrances to successful waterproofing are oil, dirt, and water, therefore, all surfaces to be waterproofed must be perfectly clean and dry. The fingers may, however, be slightly moist to prevent the Prestik P5408 sticking to them.

20 Cover, elastic, waterproofing: Manufactured from rubber and used to enclose various components. Before use, examine carefully and repair tears, splits or pin holes with adhesive tape. A spare cover of each type required to waterproof the equipment is provided in the kit.

21 Grease: Is used for the protection against salt water corrosion on certain parts. The surface should be thoroughly covered with an even, unbroken film of grease. A lumpy coating is wasteful and provides no better protection.

22 Silicone compound: Supplied in 100 g tubes and 12 oz aerosol containers for junction boxes, fuse holders and other electrical components which must remain operative at all times. The components should be covered with a generous, unbroken, even film of silicone compound.

23 Sealant, industrial, 3M EC-750-C: Supplied in tubes, industrial sealant EC-750-C is a joint sealant which dries to form a tough flexible seal, designed primarily to accommodate movement in ducting, other sheet metal fabrication and electrical cladding.

24 Fluid, water displacing, PX-24: Supplied in 1 litre containers. It is used for corrosion prevention and to wash salt water from components as detailed in this AESP.

25 Bag, envelope PVC:

25.1 These bags are manufactured in varying sizes from a waterproof material, which are used to enclose parts of the vehicle as detailed in this instruction and other items as may be desired.

25.2 Before use, the bag must be inspected for pin holes, tears or split seams, which can be repaired with suitable lengths of adhesive tape or Prestik P5408.

26 Scotch super 88 electrical insulation tape: A waterproof adhesive tape, suitable for repairing and sealing PVC bags, breathers, apertures, joints and components. The width of the tape can be increased by overlapping to the required width.

WATERPROOFING ARRANGEMENTS

27 The operations are to be carried out by Unit personnel unless otherwise stated. **THE WORK IS TO BE PLANNED AND CONTROLLED BY AN OFFICER WHO MUST ARRANGE FOR STAFF, TRAINED IN WATERPROOFING, TO INSPECT ALL TASKS PROGRESSIVELY AND TO ENSURE THAT THEY ARE COMPLETED SUCCESSFULLY.** A check list to assist operators will be found at the end of this instruction; it should be photocopied and used to check completion of each task. This list must be initialled by the operator as each task is passed as satisfactory.

CHECKING THE WATERPROOFING KIT

28 Before commencing waterproofing the vehicle, the kit must be checked against the kit list provided.

WATERPROOFING OF CARGO

29 Should it be desired to waterproof items of stores and equipment carried as cargo for which a waterproofing kit or specified suitable container is not available, use may be made of the range of BAGS, WATERPROOFING detailed below and available from Royal Logistics Corps (RLC) sources:

30 The following two PVC bags are reusable types fitted with zip closures, and primarily for use with the Trailer, Lightweight GS Cargo:

30.1 2540-99-815-9470, Bag PVC cargo (WPG 9031). 1.8 m (72 in.) x 0.9 m (36 in.) x 0.45 m (18 in).

30.2 2540-99-815-9471, Bag PVC cargo (WPG 9032). 0.9 m (36 in.) x 0.9 m (36 in.) x 0.45 m (18 in.).

Preparatory servicing

CAUTIONS

(1) **EQUIPMENT DAMAGE.** A thorough examination of build standard waterproofing must be carried out by fully trained/competent personnel. It is essential that any faults found are rectified prior to the commencement of stage 'B' waterproofing.

(2) **VEHICLE PREPARATION.** Waterproofing demands maximum efficiency of vehicle performance. Ensure that your vehicle is 100 % fit for the task.

31 Examine build standard waterproofing with reference to maintenance schedule AESP 2320-D-128- 601, Table 5, Maintenance Interval 3 months or 3000 miles (5000 km). Rectify any faults found.

31.1 Carry out 6000 miles (10000 km) servicing in accordance with AESP 2320-D-128-601, Table 7, to ensure full serviceability for fording. Do not change the engine oil or oil filter unless the vehicle is within 1000 miles (1666 km) of its next scheduled service.

31.2 Fill the vehicle fuel tank to capacity.

Prestik P5408 application

NOTE

Sealing Compound may be used as a general purpose, mouldable sealer to repair holes in damaged components or areas of potential water ingress.

32 Deleted

33 Deleted.



34 Deleted.

INTENTIONALLY LEFT BLANK

Waterproofed equipment markings

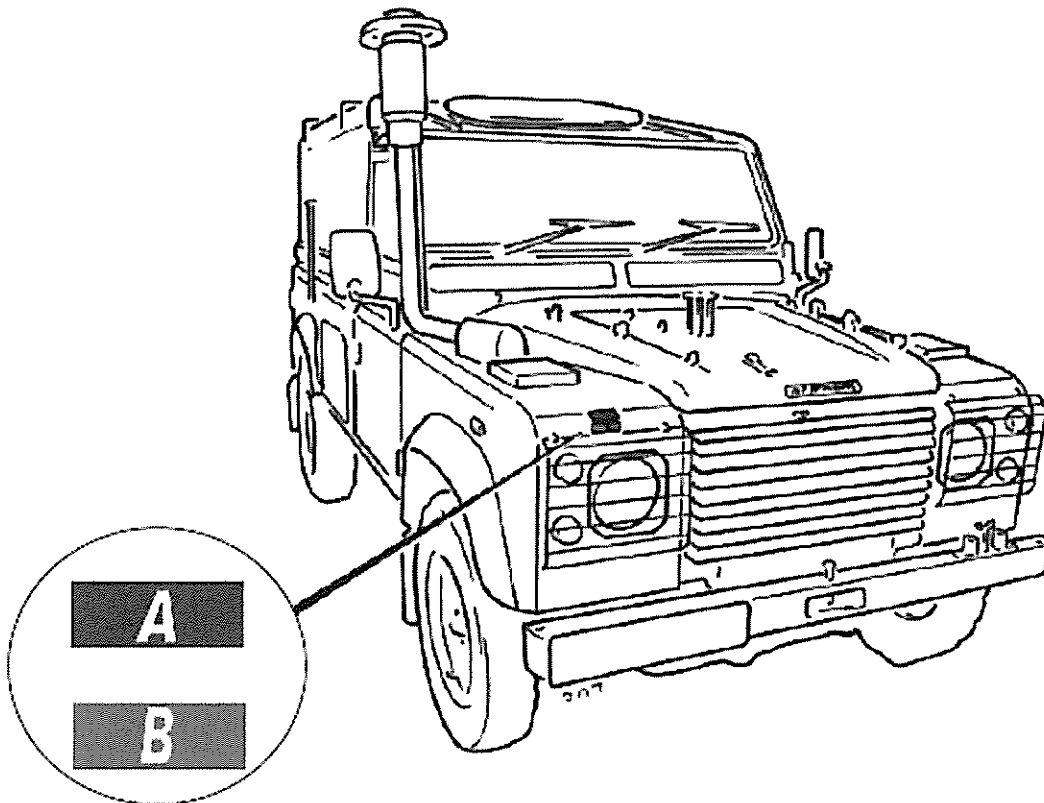
35 Ensure equipment markings are displayed correctly.



Colour meaning		Action
 Blue with white 'A' in centre	SEMI-PERMANENT Stage 'A' completed (build standard modifications)	Production build standard
 Red with white 'B' in centre	SEMI-PERMANENT Stage 'A' checked Equipment passed for disembarkation	Assembly area, on-board Landing Ship or embarkation area

NOTE

The stage 'B' marking must be covered with black adhesive tape when stage 'C' or 'D' has been completed. The marking must be uncovered when stage 'B' is completed for further fording operations.

Fig 2 Waterproofed equipment markings

Component Location

36 Refer to Fig 3 for the location of engine and ancillary components at the front of the vehicle.

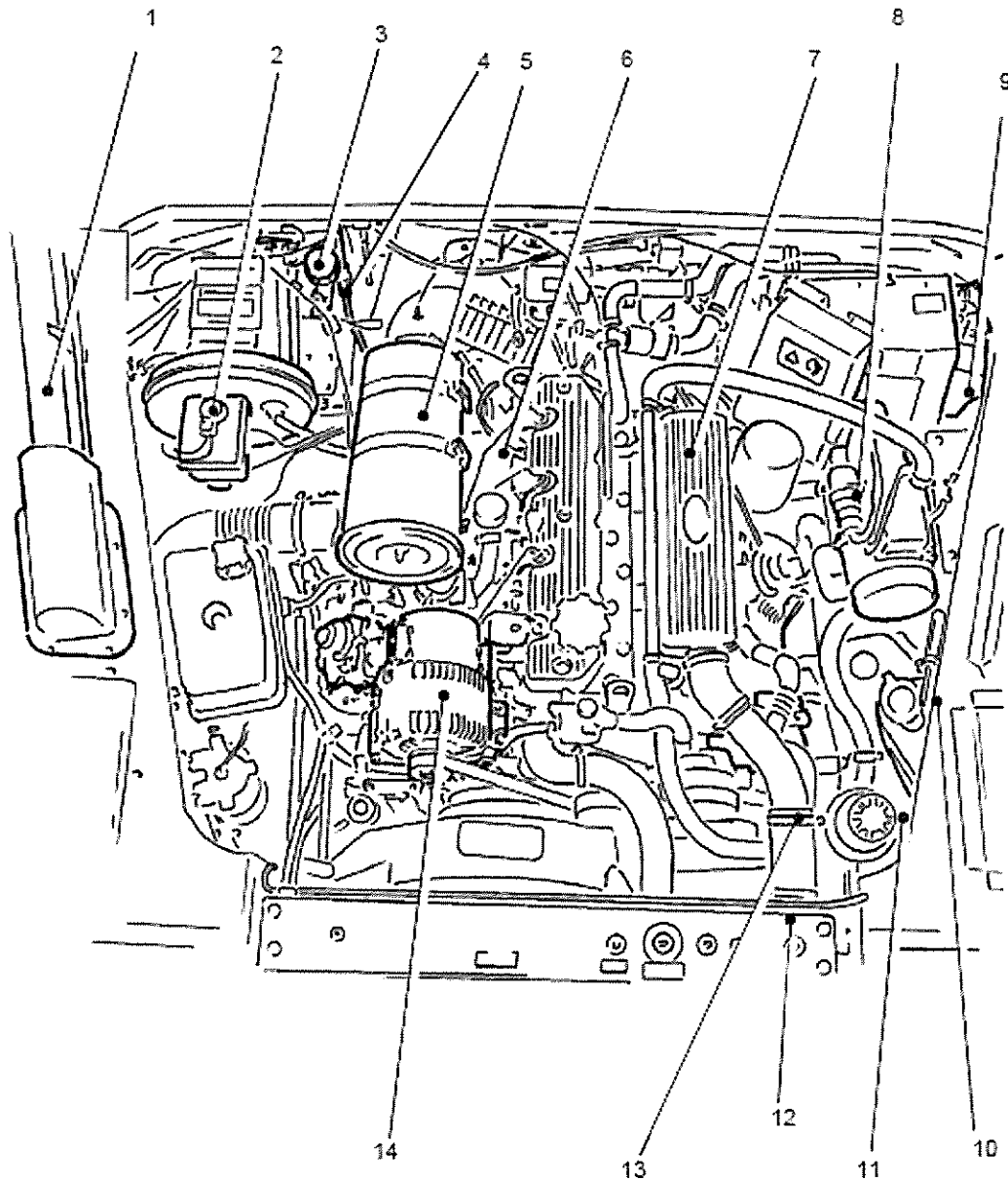

- | | |
|--------------------------------|--------------------------------|
| 1 High level engine air intake | 8 Webasto heater |
| 2 Brake fluid reservoir | 9 Vehicle heater |
| 3 Clutch fluid reservoir | 10 Alternator disconnect tool |
| 4 Fuel tank breather | 11 Windscreen washer reservoir |
| 5 Air cleaner | 12 Intercooler |
| 6 Heater plugs | 13 Alternator (lower mounted) |
| 7 Inlet manifold | 14 Alternator (upper mounted) |

Fig 3 Component layout

WATERPROOFING STAGE 'B'

CAUTION

EQUIPMENT DAMAGE. Before commencing waterproofing stage 'B', ensure that a thorough examination of build standard waterproofing has been completed in accordance with Para 31 of this instruction.

SEQUENCE OF OPERATIONS

37 Carry out this Preparation for Special Environment as follows:

NOTE

Refer to Fig 3, Component layout, for the location of individual engine/ancillary components.

TASK 1 VEHICLE BATTERIES

WARNINGS

(1) **NO SMOKING OR NAKED FLAMES. LEAD ACID BATTERIES PRODUCE POTENTIALLY EXPLOSIVE GASES.**

(2) **BATTERIES CONTAIN CORROSIVE ACID ELECTROLYTE. WEAR PROTECTIVE GLOVES AND GOGGLES WHEN HANDLING BATTERIES.**

38 Remove the passenger seat cushion and the battery compartment cover. Disconnect the negative earth cable from the battery. Temporarily refit the battery compartment cover to prevent accidental short circuiting during stage 'B' waterproofing.

TASK 2 RADIO BATTERIES (4)

WARNINGS

(1) **NO SMOKING OR NAKED FLAMES. LEAD ACID BATTERIES PRODUCE POTENTIALLY EXPLOSIVE GASES.**

(2) **BATTERIES CONTAIN CORROSIVE ACID ELECTROLYTE. WEAR PROTECTIVE GLOVES AND GOGGLES WHEN HANDLING BATTERIES.**

NOTE

This task to be carried out with the assistance of a radio operator.

39 Remove the radio battery compartment cover and slide out the battery trays.

39.1 Disconnect the negative earth cable from the radio battery. Position the cables away from the battery terminals. Slide in the battery trays.

39.2 Temporarily refit the battery compartment cover to prevent accidental short circuiting during stage 'B' waterproofing.

TASK 3 ENGINE AIR CLEANER**CAUTION**

EQUIPMENT DAMAGE. It is essential that all air cleaner hose connections and the cleaner end cover are secured correctly to provide a watertight seal on the air cleaner casing.

NOTE

This task to be carried out with the assistance of a vehicle mechanic.

40 Check that the air cleaner end cover is correctly secured against the rubber seal on the cleaner body.

40.1 Check that all hoses connected to the air cleaner, intake manifold and intercooler are secure and in good condition.

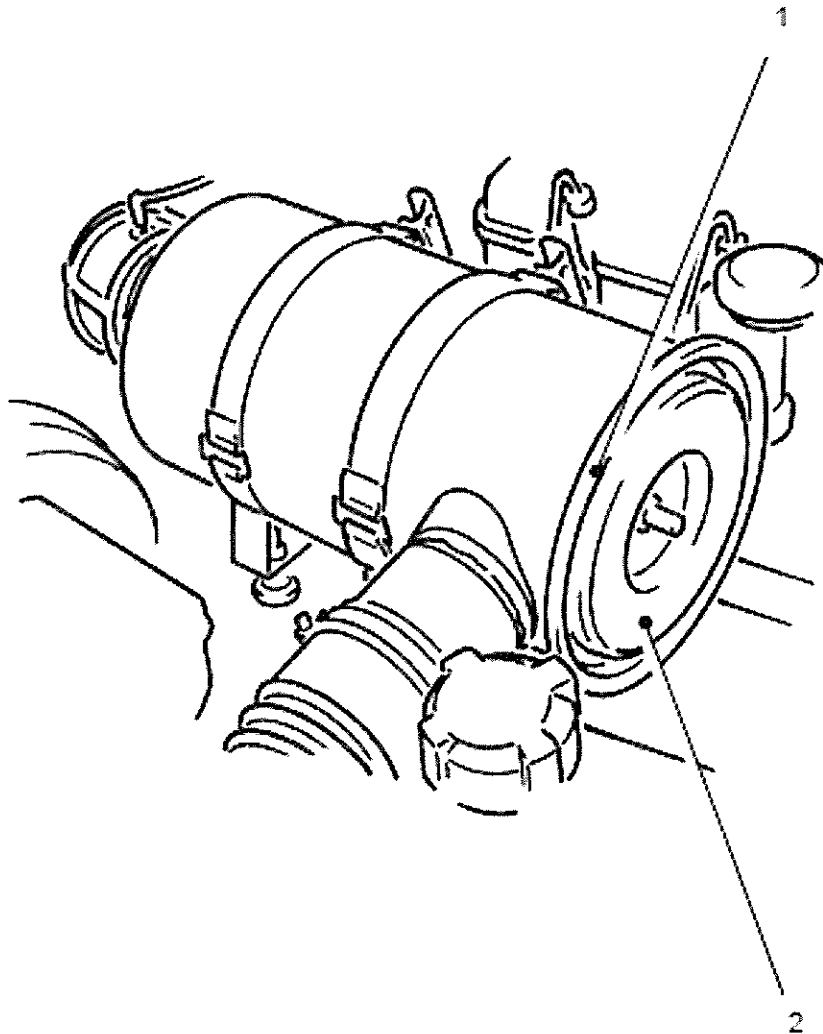

1 Rubber seal 2 End cover

Fig 4 Air cleaner

TASK 4 ALTERNATOR (UPPER MOUNTED)

CAUTION

EQUIPMENT DAMAGE. It is essential the procedure described in this task is followed exactly to isolate the charging system and avoid short circuiting.

NOTES

- (1) This task to be carried out with the assistance of a vehicle mechanic.
- (2) It is necessary to isolate the alternator charging system at both the alternator and the Fitted For Radio (FFR) terminal box.

- 41 Locate the two alternator multi-plugs attached to the alternator.
 - 41.1 Depress the multi-plug latch as shown in Fig 5 and disconnect the following:
 - 41.1.1 Red colour coded multi-plug.
 - 41.1.2 Blue colour coded multi-plug.
 - 41.2 Locate the red and blue coloured label attached to the alternator. Connect the red multi-plug to the multi-plug adjacent to the blue area of the label.
 - 41.3 Connect the blue multi-plug to the multi-plug blank adjacent to the red area of the label.

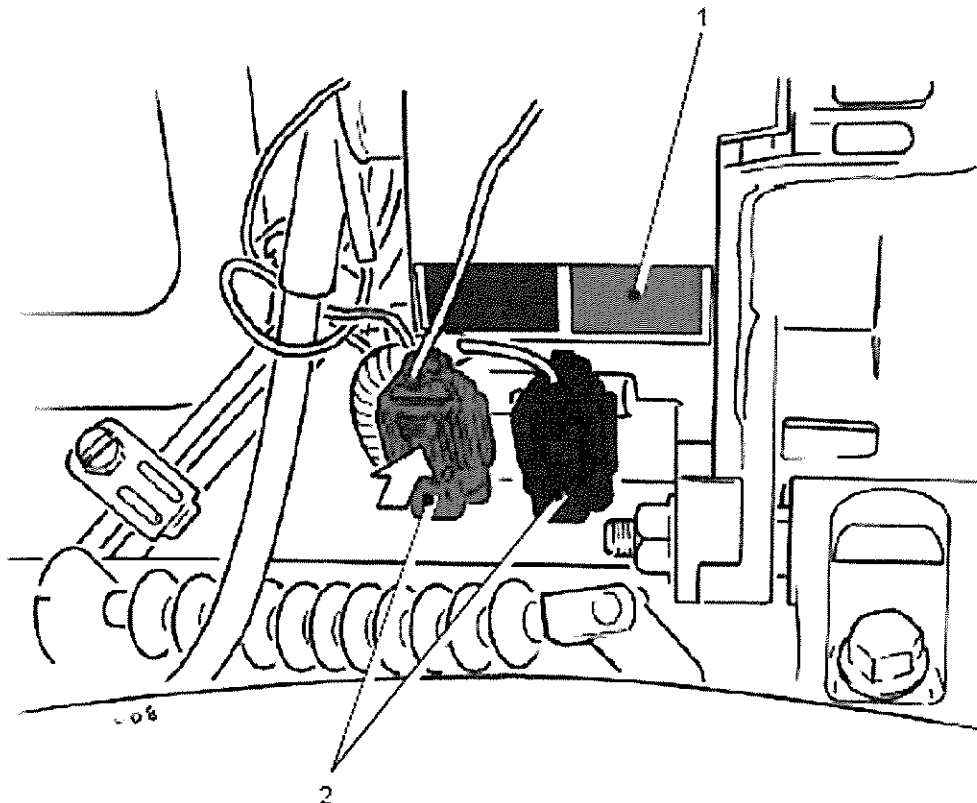

1 Label 2 Multi-plugs

Fig 5 Upper alternator disconnection

- 41.4 Locate the FFR terminal box attached to the rear bulkhead behind the front passenger seat.
- 41.5 Disconnect the radio battery cable from the terminal box.
- 41.6 Locate the blanking cap attached to the cable. Fit and tighten the blanking cap to the cable connector.
- 41.7 Secure the cable, as high as possible, to the upright of the weapon stowage bracket with 2 turns of adhesive tape (item 25).
- 41.8 Connect the grounding harness (item 23) to the FFR terminal box as shown in Fig 6.
- 41.9 . Ensure the connector is fully tightened to the terminal box.

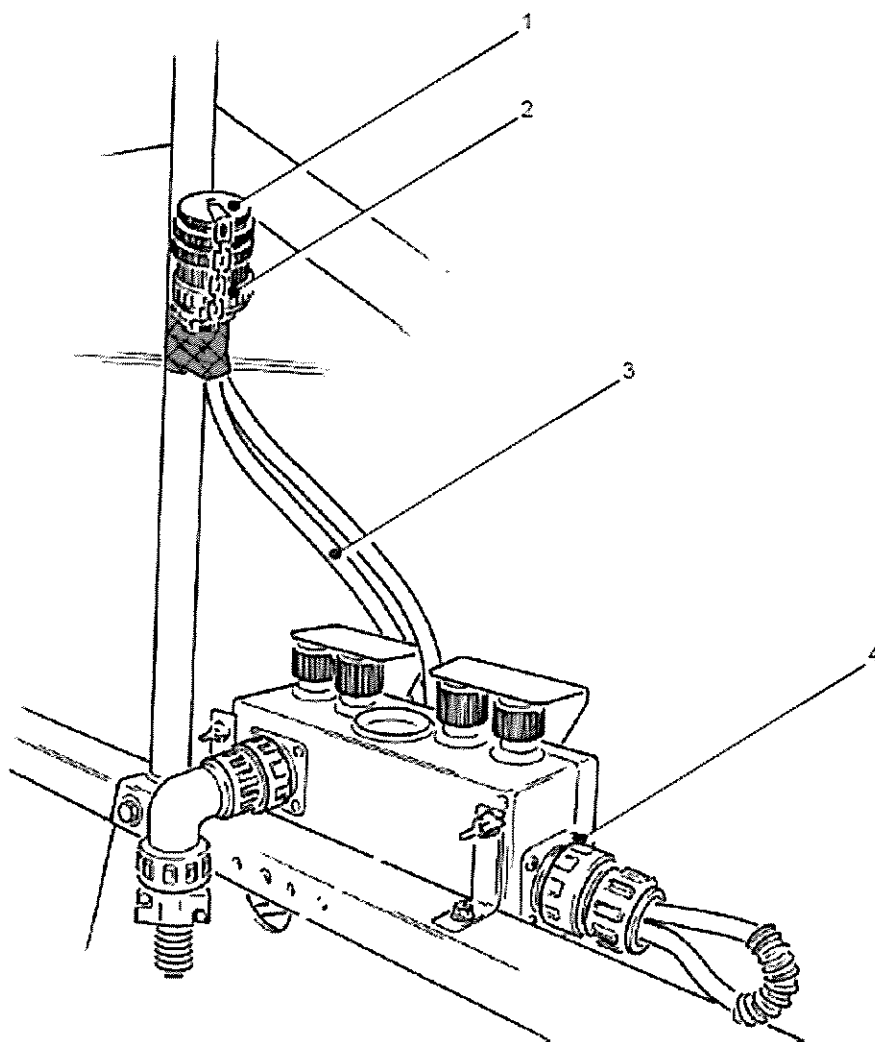

- | | | | |
|---|-----------------|---|-------------------|
| 1 | Blanking cap | 3 | Battery cable |
| 2 | Cable connector | 4 | Grounding harness |
| | | | Tape adhesive |

Fig 6 Terminal box

- 41.10 Locate the FFR charging Electronic Control Unit (ECU) attached to the rear bulkhead behind the left hand seat.
- 41.11 Detach the vehicle multi-plug.
- 41.12 Detach the dummy multi-plug.
- 41.13 Connect the dummy multi-plug to its respective halves of the vehicle multi-plug.

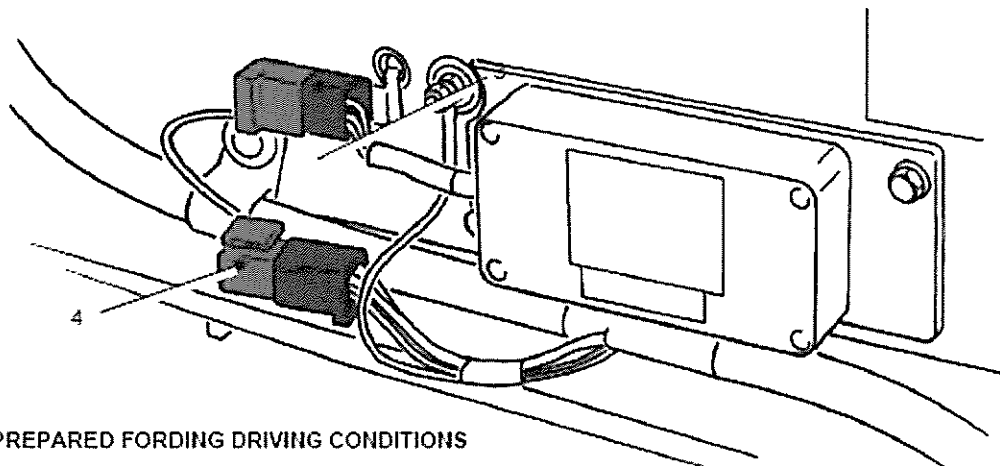
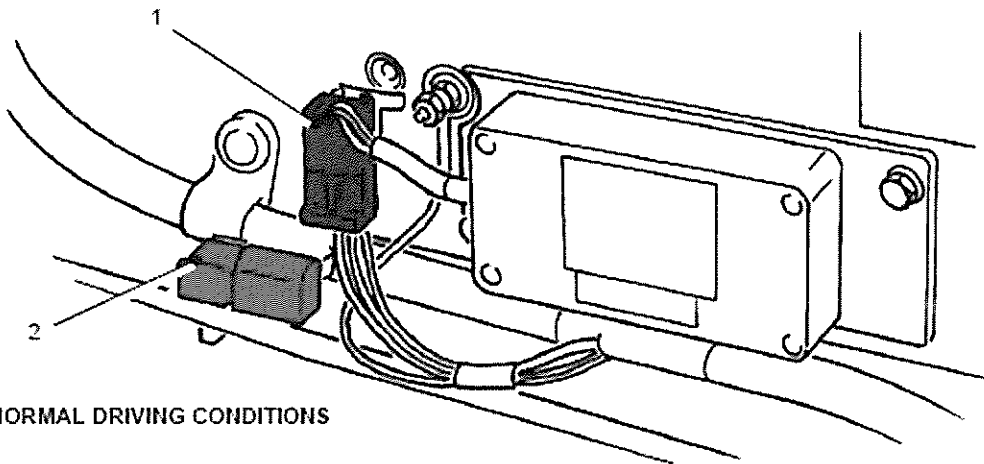

- 1 Vehicle multi-plug
- 2 Dummy multi-plug
- 3 Vehicle connection
- 4 Dummy connection

Fig 7 Charging ECU connections. Fording conditions

TASK 5 ALTERNATOR (LOWER MOUNTED)**CAUTION**

EQUIPMENT DAMAGE. It is essential the procedure described in this task is followed exactly to isolate the charging system and avoid short circuiting.

NOTES

- (1) This task to be carried out with the assistance of a vehicle mechanic.
- (2) The two alternator multi-plugs are located on a bracket attached to the alternator.

42 Locate the multi-plug disconnect tool attached to the left hand front wing, above the windscreen washer reservoir. Remove the tool from its clip.

42.1 Using the tool as shown in Fig 8, depress the multi-plug latch, applying light pressure only and disconnect the following:

42.1.1 Red colour coded multi-plug.

42.1.2 Blue colour coded multi-plug.

42.2 Replace the disconnect tool to its original location.

42.3 Connect the free section of the red multi-plug to the fixed section of the blue multi-plug.

42.4 Connect the free section of the blue multi-plug to the fixed section of the red multi-plug.

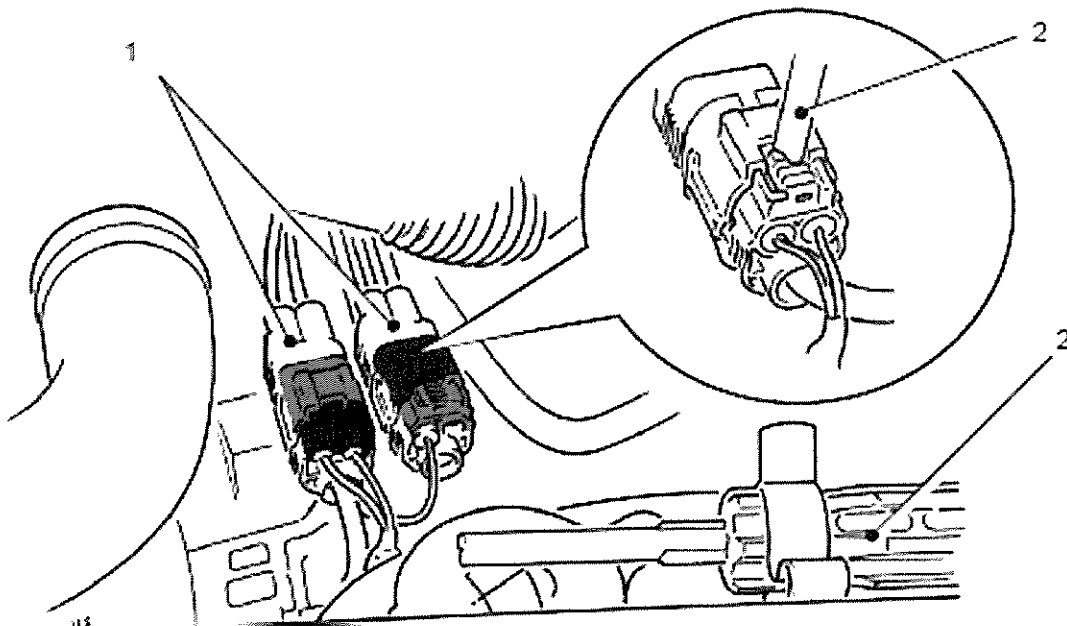

1 Multi-plugs 2 Disconnect tool

Fig 8 Lower alternator disconnection

42.5 Slacken the wing screw clamp and disconnect the breather hose from the rear of the alternator. Remove the clamp from the hose and place in a plastic bag (item 26).

NOTE

The breather hose is located on the underside of the alternator end cover. Access is difficult and care must be taken not to damage any of the intercooler pipes.

42.6 Position the breather hose clear of moving parts and exhaust manifold.

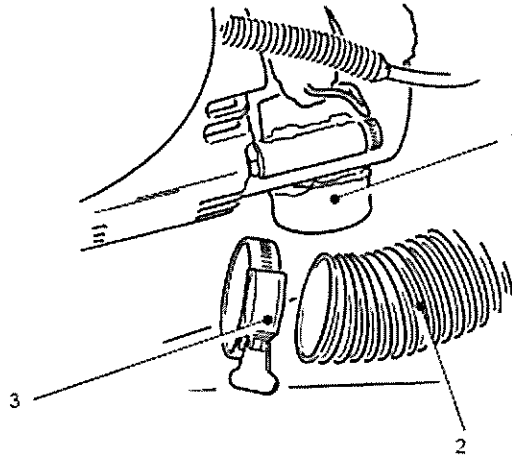

Fig 9 Alternator breather

TASK 6 CLUTCH FLUID RESERVOIR

43 Ensure the reservoir filler cap is tight. Stretch a rubber cover (item 5) over the cap so that edge of cover seals on reservoir body.

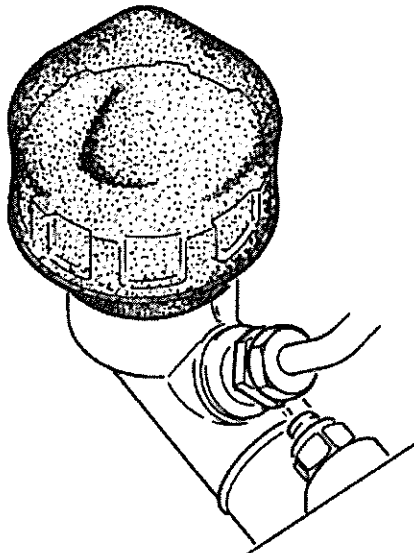

Fig 10 Clutch fluid reservoir

TASK 7 BRAKE FLUID RESERVOIR**WARNING**

BRAKE FLUID. HYDRAULIC FLUID IS A TOXIC SUBSTANCE WHICH MUST NOT BE CONSUMED OR ALLOWED TO COME INTO SKIN/EYE CONTACT. IN THE EVENT OF SLIGHT SKIN/EYE CONTACT, THOROUGHLY RINSE THE AFFECTED AREA WITH WATER. IF THERE IS EXCESSIVE SKIN/EYE CONTACT OR INGESTION/INHALATION SEEK MEDICAL ATTENTION IMMEDIATELY.

CAUTION

BRAKE FLUID. Brake fluid will damage paintwork, if any brake fluid comes into contact with the paintwork, immediately wash down with a large quantity of freshwater and wipe clean with a soft cloth.

44 Depress the latch as shown in Fig 11 and disconnect the fluid level sensor multi-plug. Connect a blanking plug (item 13) to the harness multi-plug.

NOTE

With the blanking plug (item 13) fitted, the red brake circuit check warning light on the centre console will illuminate at all times with the ignition key in the 'ON' position.

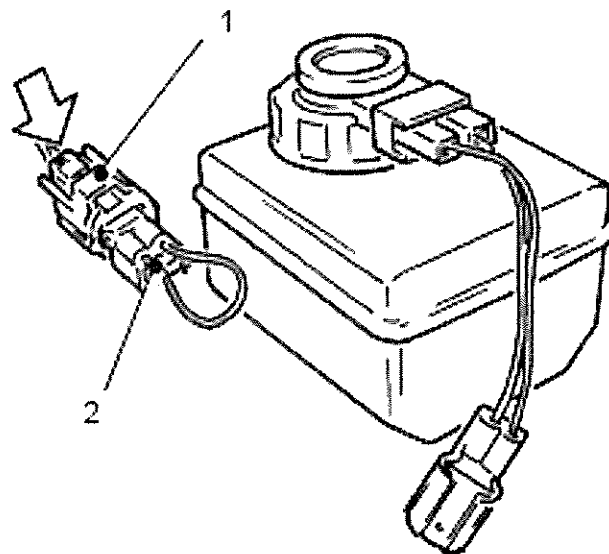

1 Harness multi-plug 2 Blanking plug

Fig 11 Fluid level sensor

44.1 Slacken the reservoir filler cap sufficiently to gain access. Do not remove the filler cap.

44.2 Stretch a rubber cover (item 4) over the cap and sensor harness. Position open end of between edge of cap and reservoir to form a sealing surface, as shown in Fig 12. Tighten cap clamping the cover to the reservoir body.

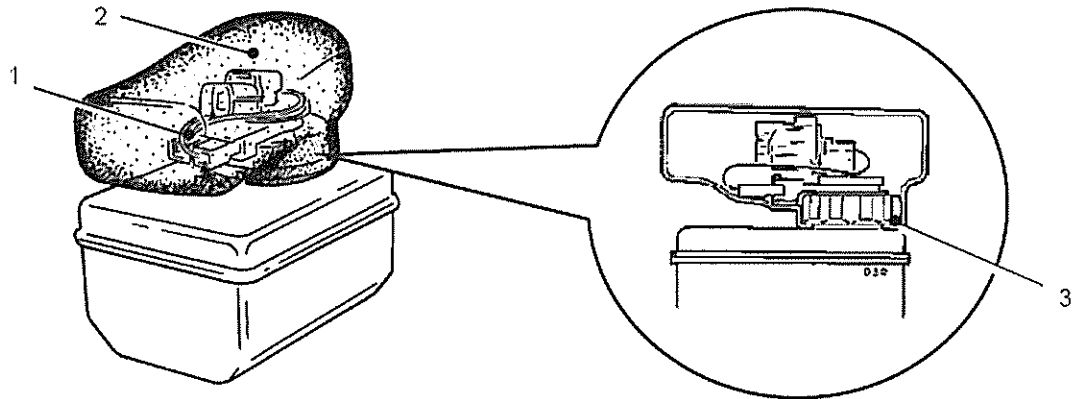

- 1 Sensor harness
- 2 Cover
- 3 Cover sealing surface

Fig 12 Brake fluid reservoir

TASK 8 HEATER PLUGS

NOTES

- (1) Do not remove any engine parts when carrying out this task.
 - (2) For clarity the air cleaner and breather cyclone are not shown in Fig 13.
- 45 Fill spray container (item 24) with PX-24 water displacement fluid (item 33).
- 45.1 Spray an even coat of PX-24 from container over each of the four heater plug terminal connections for protection against the effects of sea water.

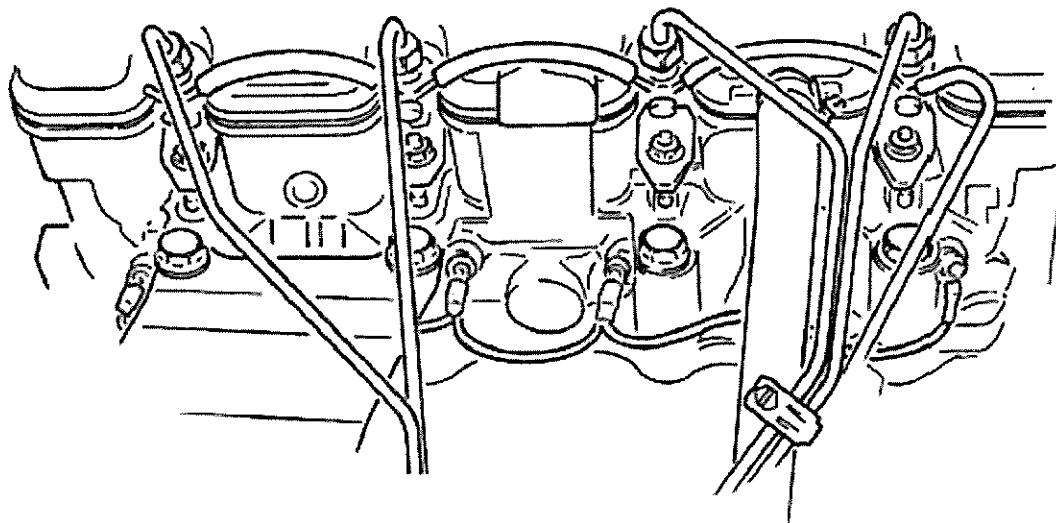

PX-24

Fig 13 Heater plugs

TASK 9 WINDSCREEN WASHER RESERVOIR**WARNING**

HEALTH HAZARD. FLUID AL 11 IS HIGHLY INFLAMMABLE. THE PREPARATION OF THE FLUID FOR WINDSCREEN WASHERS IS TO BE CARRIED OUT IN THE OPEN AND AWAY FROM NAKED FLAME. MINIMUM PRECAUTION AFTER USE IS TO WASH ANY AFFECTED SKIN AREAS WITH SOAP AND WATER.

CAUTION

EQUIPMENT DAMAGE. It is essential that the windscreen washer reservoir is filled as detailed in this task to avoid contamination by sea water and subsequent damage to the screen wash equipment.

- 46 Fill the windscreen washer reservoir to the bottom of the filler neck with a mixture of AL11 (item 38) and water. Refit the reservoir filler cap.

TASK 10 FUEL TANK BREATHER

NOTE

Fuel tank breather connector is located in the engine compartment adjacent to the clutch fluid reservoir.

47 Depress the connector latches as shown in Fig 14 and disconnect the fuel tank breather pipe from the blue colour coded vent pipe.

47.1 Connect the fuel tank breather pipe to the red colour coded pipe of the component breather system.

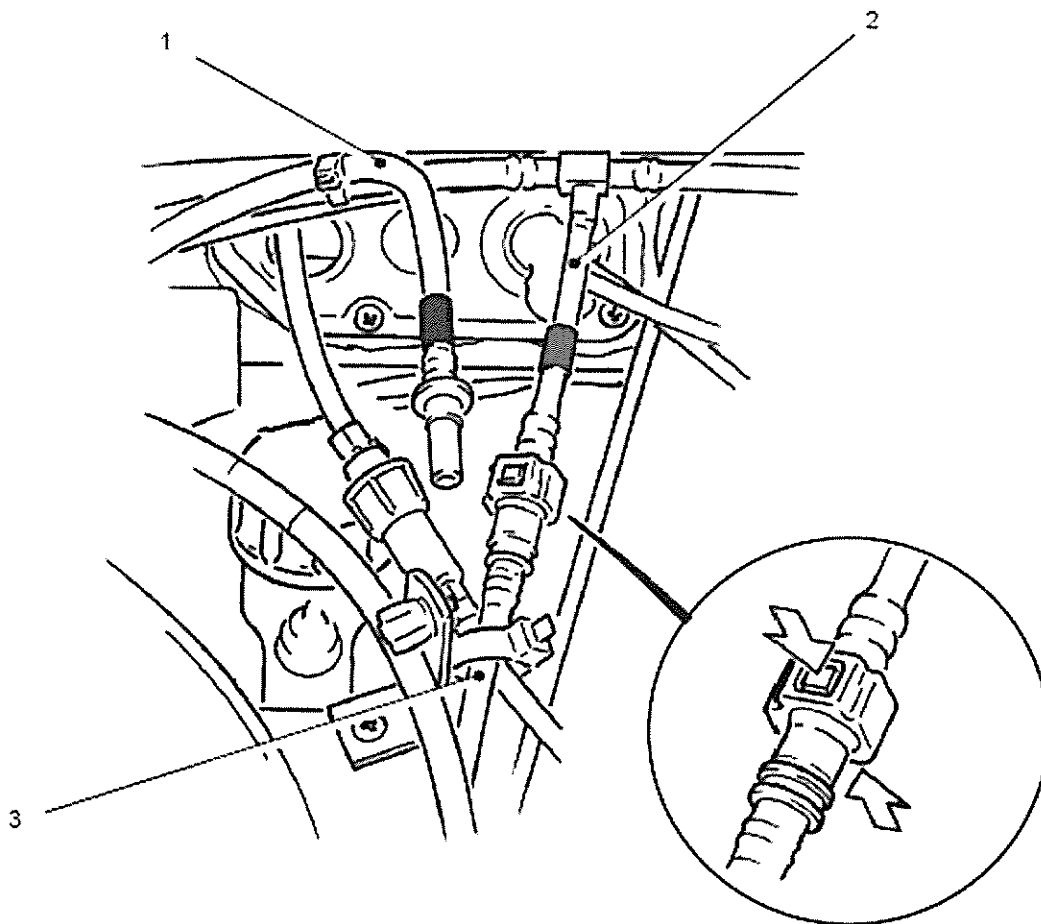

1 Blue colour coded vent pipe

3 Fuel tank breather pipe

2 Red colour coded Component breather system

Fig 14 Fuel tank breather

TASK 11 WEBASTO HEATER**NOTE**

This task to be carried out with the assistance of a vehicle mechanic.

48 Slacken the wing screw clamp securing the intake pipe to the heater and remove the intake pipe. Remove the clamp from the pipe, it will be required later in this task.

48.1 Slacken the clamps and disconnect the exhaust pipe from the heater. Remove the exhaust pipe connection sleeve complete with clamps. Do not remove any other exhaust system parts.

48.2 Place air intake pipe and exhaust connection sleeve in a plastic bag (item 26).

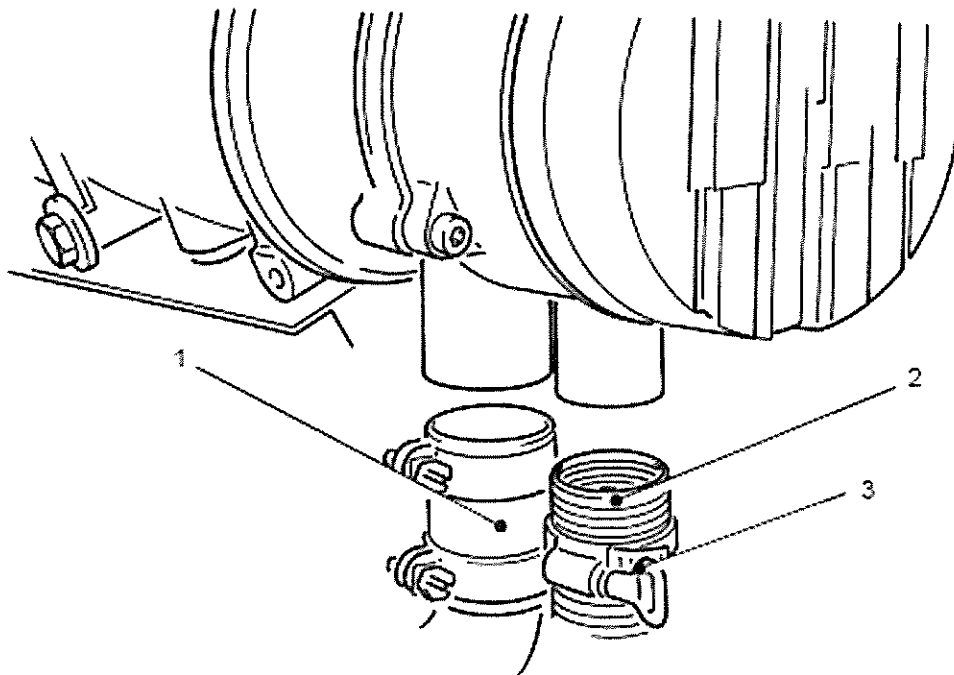

- 1 Exhaust connection sleeve 3 Wing clamp
2 Intake pipe

Fig 15 Webasto heater

- 48.3 Fit a cap (item 7) over the heater air intake port. Secure cap with the original intake pipe clamp.
- 48.4 Fit a cap (item 8) over the heater exhaust port. Secure cap with clamp (item 9).

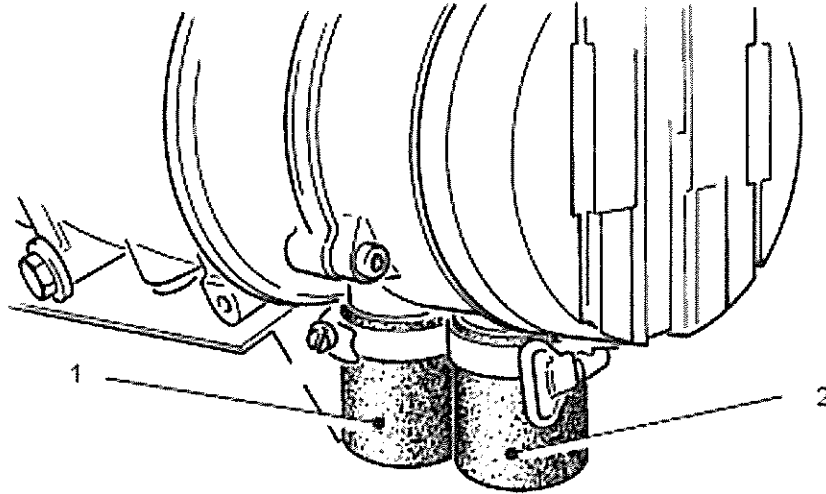

1 Exhaust cap 2 Intake cap

Fig 16 Webasto caps

- 48.5 Locate the Webasto control switch on the centre console in the driver's cab. Ensure the switch is in the 'OFF' position. Prise the control knob from the switch and place in a plastic bag (item 26). This is done to prevent accidental operation of the heater during fording operations.

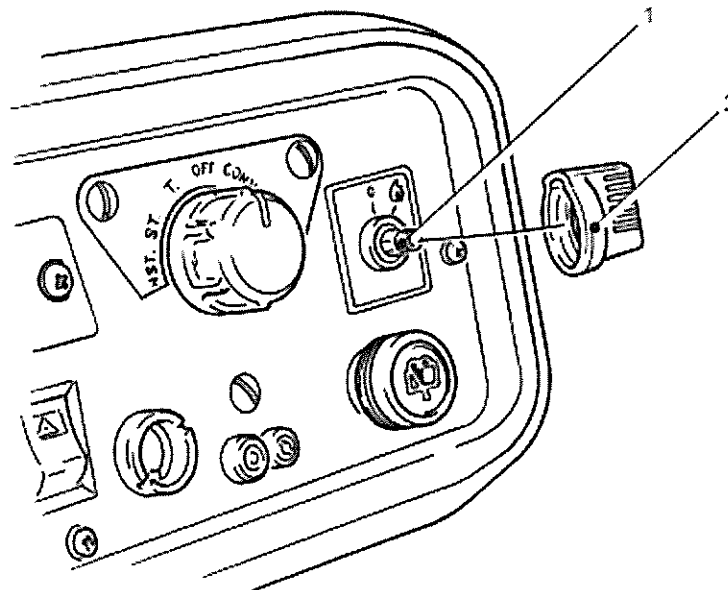

1 Switch 2 Control knob

Fig 17 Webasto switch

TASK 12 HEATER**NOTE**

The two heater multi-plugs are attached to the heater unit at the rear of the engine compartment.

49 Depress the latch as shown in Fig 18 and disconnect the grey and orange multi-plugs.

49.1 Connect the grey multi-plug to the orange multi-plug blank.

49.2 Connect the orange multi-plug to the grey multi-plug.

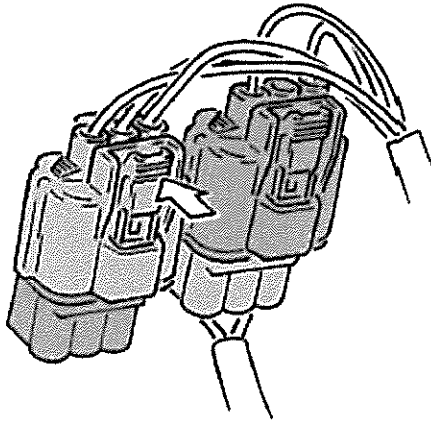
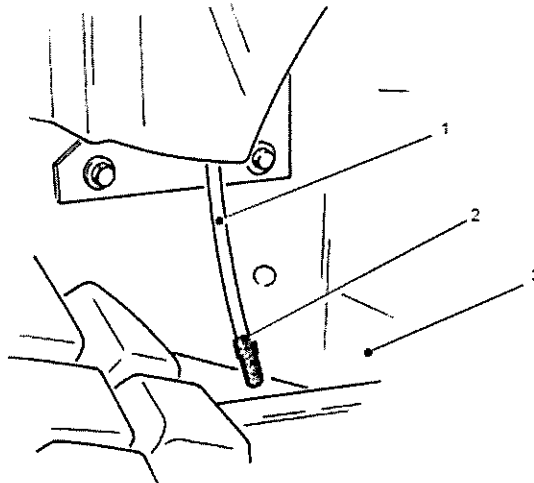

Fig 18 Heater multi-plugs

NOTE

The motor drain tube is situated at the rear of the left hand front wheel arch adjacent to the chassis side member. Access is gained beneath the left hand front wing.

49.3 Fit a cap (item 12) over the end of the motor drain tube.



1 Drain tube 3 Chassis side member
2 Cap

Fig 19 Motor drain

TASK 13 STEERING COLUMN SWITCHES

50 Release the indicator and wiper switch rubber covers from the steering column switch box. Do not remove the rubber covers from the switch stalks. Fit the large end of the covers inside the apertures on the box.

50.1 Stretch a rubber cover (item 6) over indicator switch, position edge of cover over the boss on the steering column box.

50.2 Stretch a rubber cover (item 6) over wiper switch, position edge of cover over the boss on the steering column box.

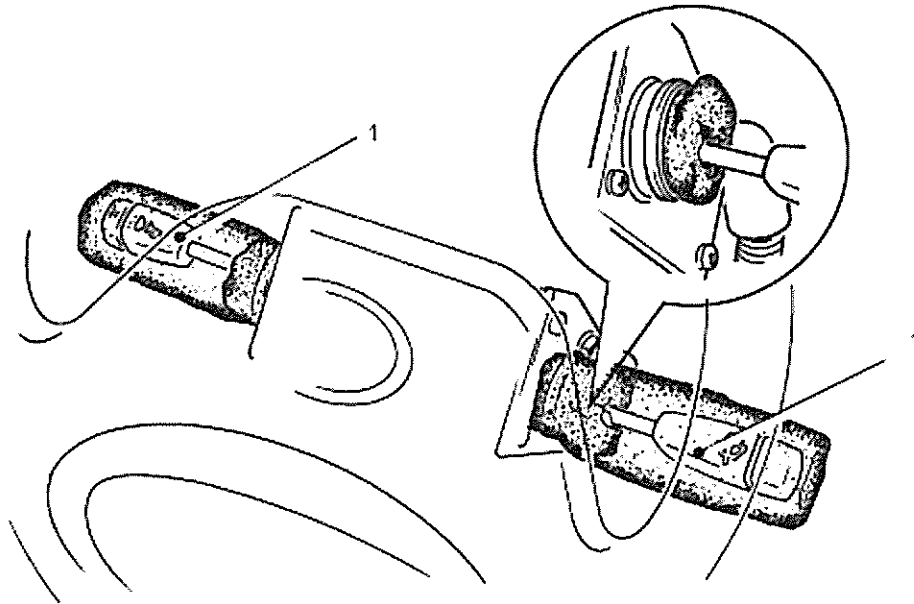

1 Rubber cover

Fig 19 Steering column switches

TASK 14 DELETED

51 Deleted.

Fig 20 Deleted

TASK 15 INTER-VEHICLE START SOCKET

52 The Inter-vehicle start socket is located in the passenger side footwell. Remove socket cap. Apply an even coat of silicone compound (item 32) over socket threads and socket rubber seal using an artist's brush (item 27). Refit and tighten cap.

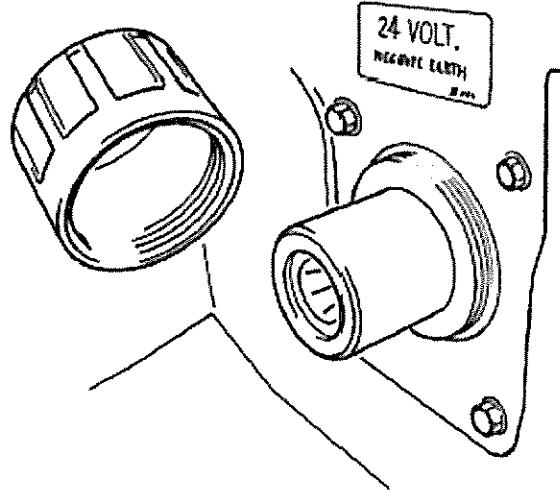

Silicone compound

Fig 21 Inter-vehicle start socket

TASK 16 FRONT WIPER MOTOR**NOTE**

The front wiper box is located inside the cab on the left hand side of the dashboard below the passenger grab rail.

53 Press a tapered silicone plug (item 16) into the wiper box drain hole on the underside of the box. Ensure the plug is a firm fit with no possibility of it being dislodged.

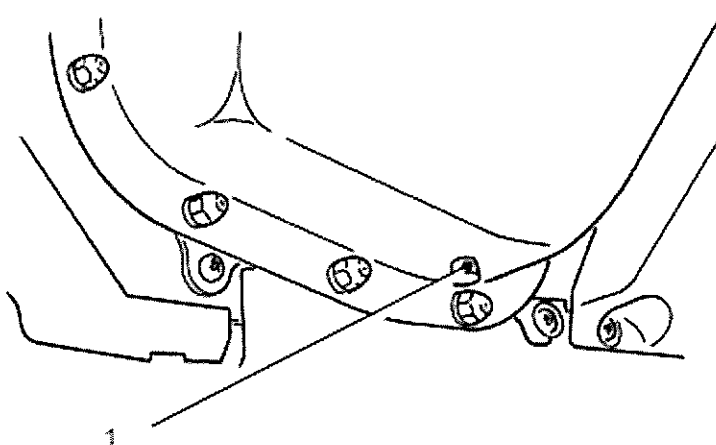

1 Tapered silicone plug

Fig 22 Front wiper box

TASK 17 FRONT SEAT BELTS

NOTE

This task to be carried out with the assistance of a vehicle mechanic.

54 Remove inertia reel seat belt units and anchorage engagement/release assembly stalks from vehicle. Discard the cardboard washers from the belt and stalk securing bolts, these are only used for production assembly purposes by the vehicle manufacturer. Refit all securing bolts, nuts, spacers and remaining washers to vehicle.

54.1 Place all seat belt equipment in a stowage bag (item 22).

TASK 18 REAR SEAT BELTS

55 Uncouple and remove the rear seat belts.

55.1 Place the rear seat belts in a stowage bag (item 22).

TASK 19 REAR WIPER MOTOR

NOTE

The rear wiper box is located on the inside of the rear door.

56 Press a tapered silicone plug (item 16) into the wiper box drain hole on the underside of the box. Ensure the plug is a firm fit with no possibility of it being dislodged.

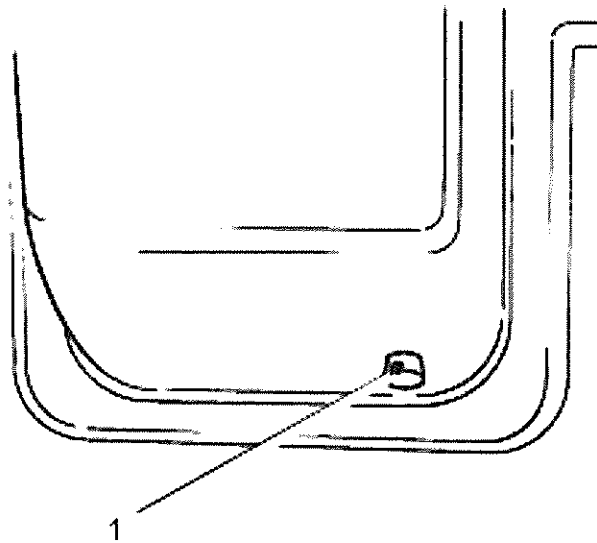

1 Tapered silicone plug

Fig 24 Rear wiper box

TASK 20 FLYWHEEL HOUSING

57 Fit and tighten drain plug (item 15) to flywheel housing.

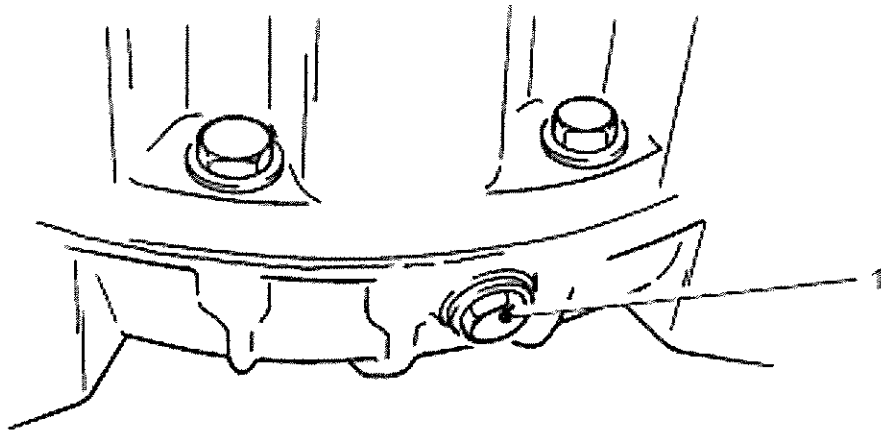

1 Drain plug

Fig 25 Flywheel housing

TASK 21 NUMBER PLATE LAMPS

58 Stretch a cover (item 17) over the number plate lamp and lamp adaptor plate. Position edge of cover around the lamp spacer block.

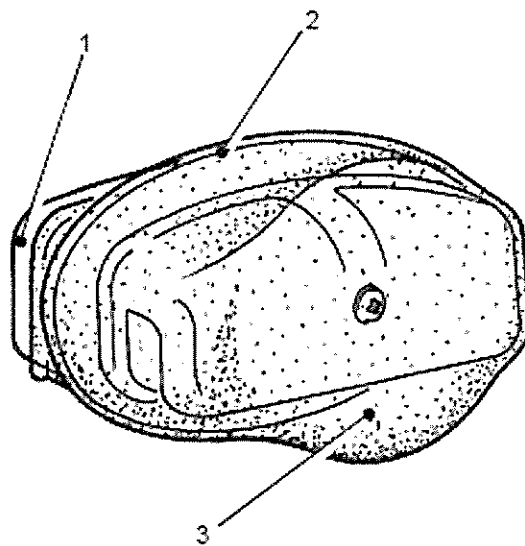

1 Spacer block 3 Rubber cover
2 Adaptor plate

Fig 26 Number plate lamp

TASK 22 NATO 12 PIN TOWING SOCKET

59 When not in use, lift the spring loaded cover and apply a liberal coat of silicone compound (item 32) to the socket terminals using an artist's brush (item 27). Close cover.

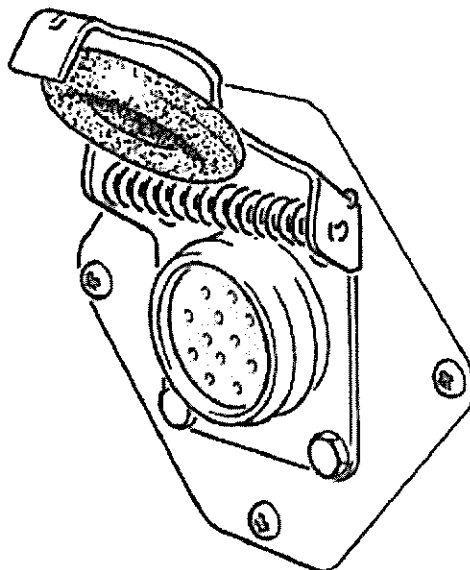

Silicone compound

Fig 27 Towing socket terminals

TASK 23 CENTRE CONSOLE**CAUTIONS**

(1) **EQUIPMENT DAMAGE.** It is essential that all covers are correctly located to provide a watertight seal on the centre console.

(2) **EQUIPMENT DAMAGE.** It is essential that the waterproofing cover is fitted before the drain plug. This is to avoid air being trapped in the console during fitting that would prevent correct location of the cover.

60 Remove any keys or key rings from the ignition key and place in a plastic bag (item 26). Fit the key to the ignition switch and ensure that all switches in the centre console are in the 'OFF' position.

60.1 Stretch a rubber cover (item 5) over the ignition switch boss on the console cover (item 2). Press the cover through the switch aperture as shown in Fig 28.

60.2 Ensure the rubber cover remains fully located on the switch boss. Secure the rubber cover to the switch boss with a cable tie (item 30).

60.3 Apply a thin even coat of silicone compound (item 32) to the edge of the console cover using an artist's brush (item 27). Ensure the silicone compound does not contaminate the ignition switch rubber cover and is applied only to the areas shown in Fig 28.

NOTE

Silicone compound is applied to aid the fitting of the console cover.

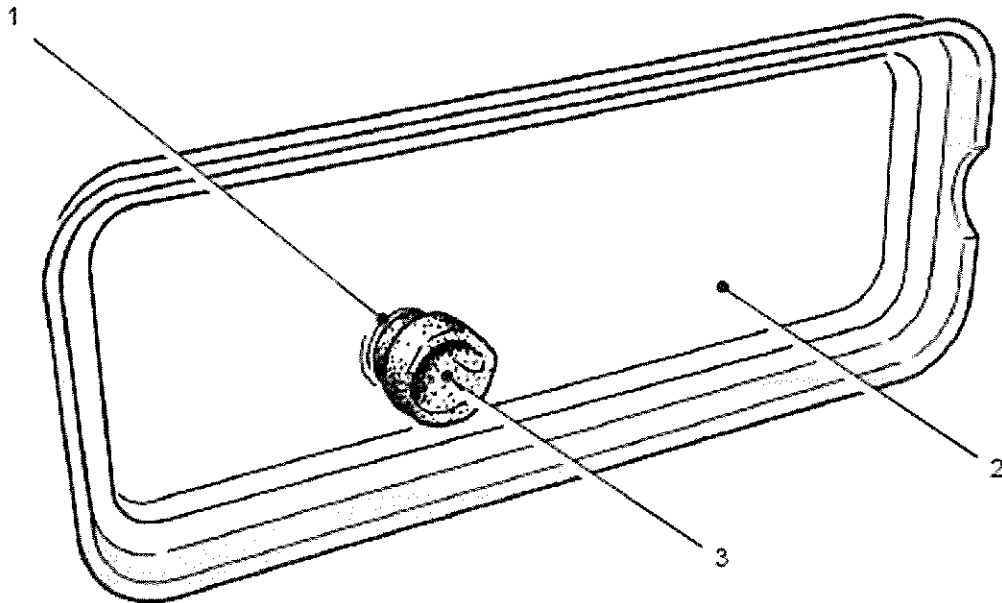

- | | |
|-------------|----------------|
| 1 Cable tie | 3 Rubber cover |
| 2 Cover | |

Silicone compound

Fig 28 Console cover

60.4 Position cover centrally over the rubber seal around the edge of the centre console with the switch aperture located over the ignition switch. Carefully press the cover over the seal until it is fully located onto the box. Ensure all edges of the cover are fully located.

60.5 Loop the cover retaining strap (item 3) over the left hand edge of the centre console, twist the strap to form a second loop. Pass the second loop over the front of the cover and secure to the right hand edge of the console. Ensure that the retaining strap is located over each of the four corners of the centre console.

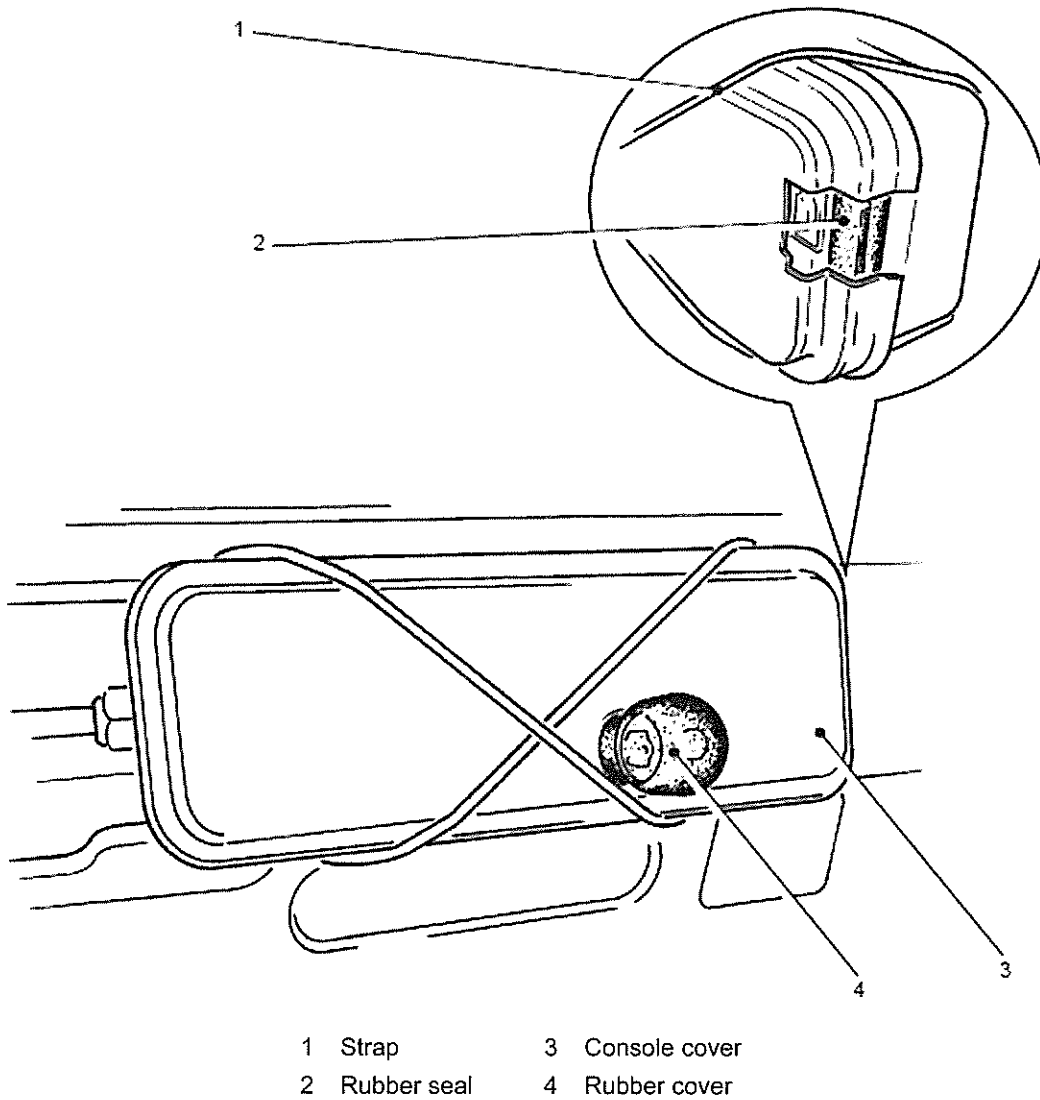
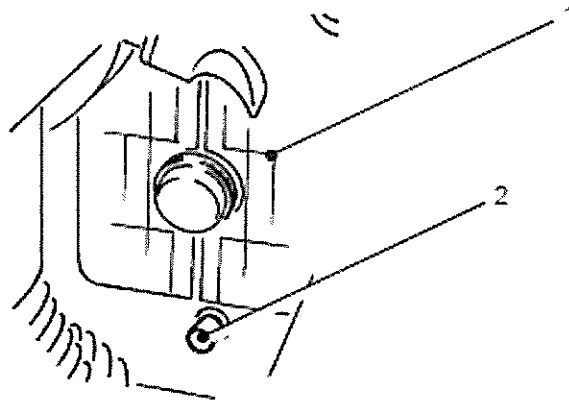

Fig 29 Centre console

60.6 Locate the drain hole on the left hand side of the console below the fuse cover. Press a tapered silicone plug (item 16) into the drain hole. Ensure the plug is a tight fit with no possibility of it being dislodged.



1 Fuse cover 2 Tapered silicone plug

Fig 30 Console drain

60.7 Ensure the map lamp bulb holder is screwed tight to the lamp stalk. Locate the rubber lamp cover attached to the dashboard and fit over the bulb holder. If the rubber cover is missing or damaged, fit rubber cover (item 10) over the bulb holder.

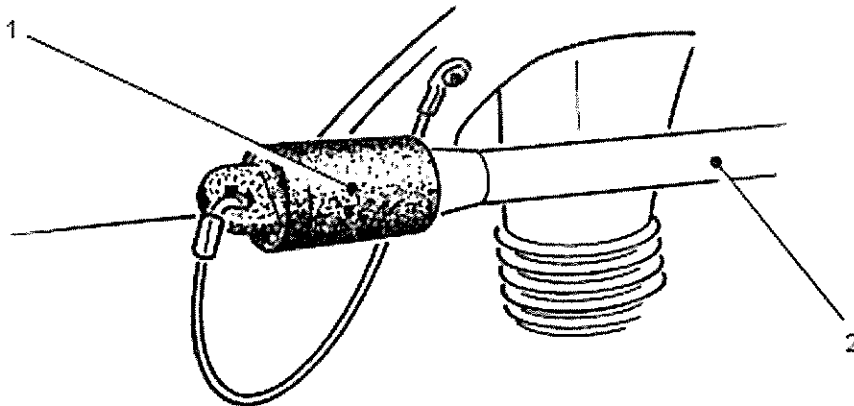

1 Rubber cover 2 Lamp stalk

Fig 31 Map lamp

60.8 With the covers fitted to the centre console the procedure for starting the engine is as follows:

- 60.8.1 Grip the ignition key through the rubber cover and turn to the first position.
- 60.8.2 Wait approximately ten seconds for the engine heater plugs to operate.
- 60.8.3 Start engine.

TASK 24 BATTERIES (2)

WARNINGS

- (1) **NO SMOKING OR NAKED FLAMES. LEAD ACID BATTERIES PRODUCE POTENTIALLY EXPLOSIVE GASES.**
- (2) **BATTERIES CONTAIN CORROSIVE ACID ELECTROLYTE. WEAR PROTECTIVE GLOVES AND GOGGLES WHEN HANDLING BATTERIES.**

NOTE

Deleted.

61 Reconnect the negative earth cable disconnected at Task 1 to the battery. Apply a liberal coat of PX-7 grease (item 36) to all battery terminals, ensuring they are completely covered. Refit the covers over the battery terminals. Refit the battery compartment cover and front seat cushion to the vehicle.

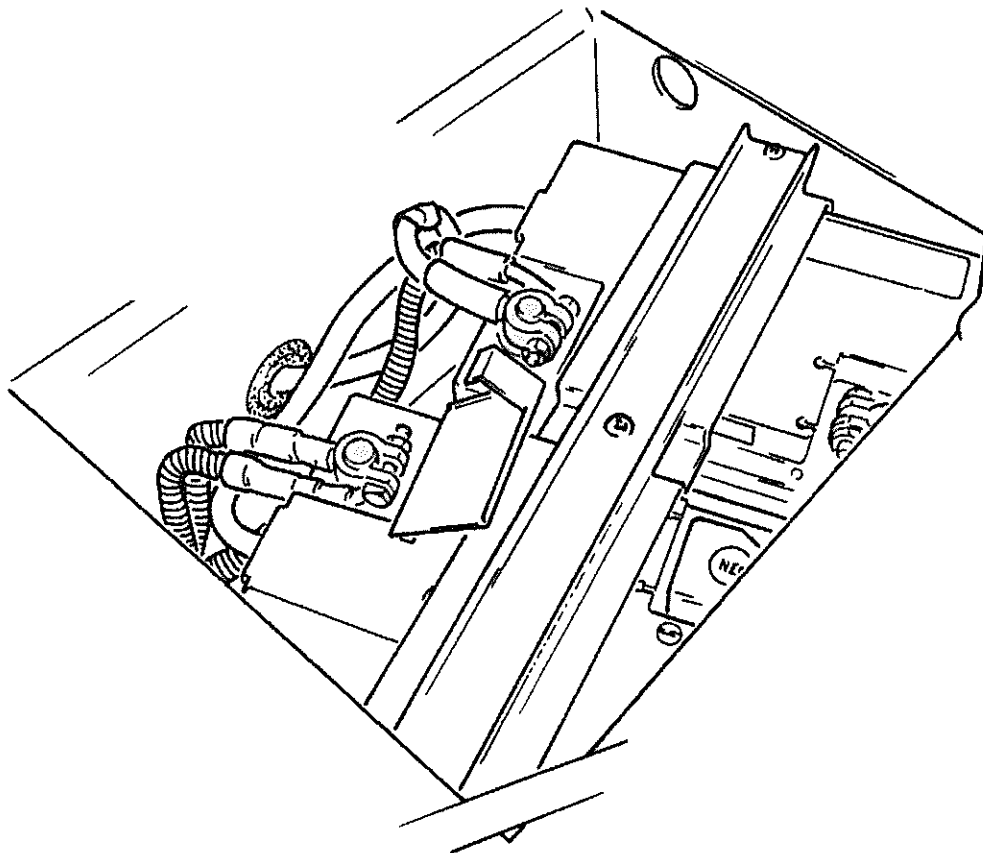

Fig 31 Batteries

TASK 25 TUL FFR BOWMAN RADIO BAG**NOTES**

- (1) This task to be carried out with the assistance of a radio operator.
- (2) This task is only to be completed when waterproofing a Truck Utility Light (TUL) HS FFR BOWMAN installation. Refer to Task 26 for waterproofing the Truck Utility Medium (TUM) HS FFR BOWMAN installation.

62 Examine the TUL FFR BOWMAN radio bag for damage. Small areas of damage can be rectified using the repair kit (item 41).

62.1 The Personal User Data Terminal (PUDT) is located between the front seats. Disconnect the cable leads to the PUDT. Remove the PUDT and the power converter together by unbolting the four mounting bolts. Stow and secure the PUDT and power converter inside the TUL FFR BOWMAN waterproof bag. Remove the cable ties that secure the PUDT cable leads to the vehicle. Stow the leads inside the TUL FFR BOWMAN waterproof bag through the front zip opening.

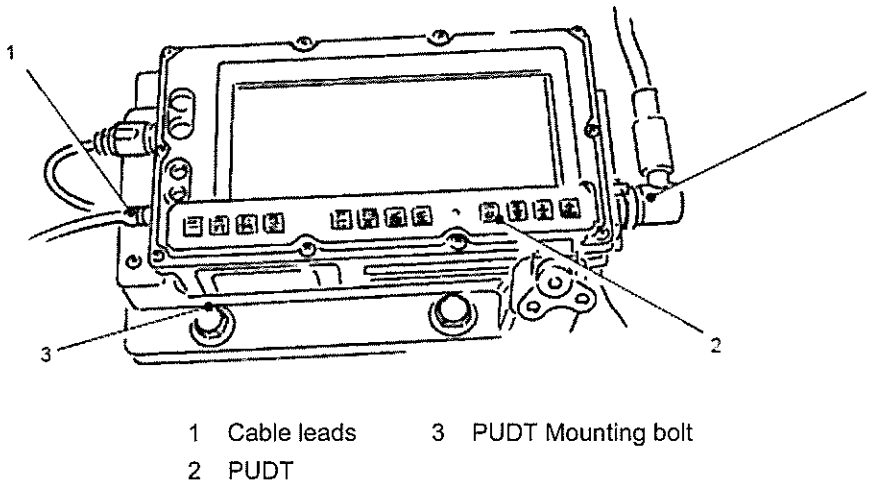

Fig 32 PUDT removal

62.2 The Radio Selector Box (RSB) is located behind the passenger seat. Disconnect the RSB cable lead. Remove the cable ties that secure the lead to the vehicle and stow the lead inside the TUL FFR BOWMAN waterproof bag through the front zip opening. Disconnect the earth terminal from the mounting frame. Unclamp the two RSB mounting bolts. Remove the RSB, stow and secure the RSB inside the TUL FFR BOWMAN waterproof bag.

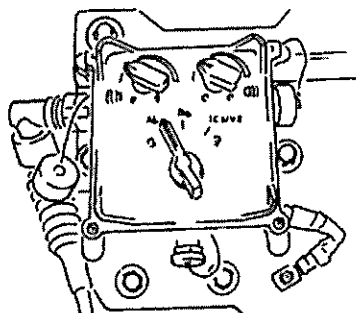
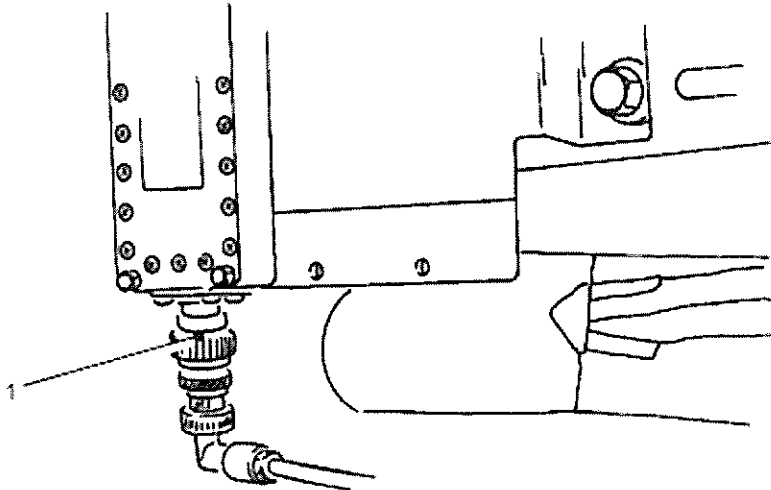

Fig 33 RSB removal

62.3 The main power distribution box is located behind the passenger's front seat. Disconnect the positive (red) and negative (black) terminal leads. Stow the leads inside the TUL FFR BOWMAN waterproof bag through the front zip opening.

62.4 The Band Pass Filter (BPF) is located inside the bag behind the passenger front seat. Disconnect the cable from the BPF, pass through the front zip opening and secure to the roll over bar above fording depth.



1 BPF Cable

Fig 35 BPF cable disconnect

62.5 The Automatic Antenna Coupling (AAC) earth lead is located inside the bag on the right hand side wall bracket. Unclamp and remove the earth cable from the right hand side of the vehicle bodywork. Stow the lead inside of the bag clear of the bag zip. Refit the earth lead clamping bolt to the vehicle.

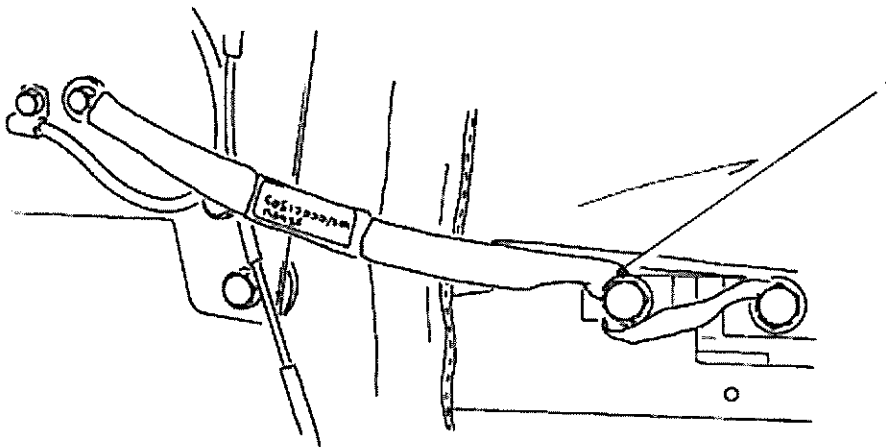

1 Earth lead clamp bolt

Fig 36 AAC earth cable disconnect

62.6 Ensure that all equipment removed is securely stowed inside the waterproof bag. Close the front and rear zips of the waterproof bag.

TASK 26 TUM FFR BOWMAN RADIO BAG

NOTE

- (1) This task to be carried out with the assistance of a radio operator.
- (2) This task is only to be completed when waterproofing a TUM (HS) FFR BOWMAN installation. Refer to Task 25 for waterproofing the TUL (HS) FFR BOWMAN installation.

63 Examine the TUM FFR BOWMAN radio bag for damage. Small areas of damage can be rectified using the repair kit (item 41).

63.1 The PUDT is located between the front seats in the cab. Disconnect the PUDT cable leads. Remove the PUDT and the external keyboard complete from the vehicle. Stow and secure the PUDT and keyboard inside the BOWMAN waterproof bag. Remove the cable ties that secure the PUDT cable leads to the vehicle. Stow the leads inside the TUM FFR BOWMAN waterproof bag through the front zip opening.

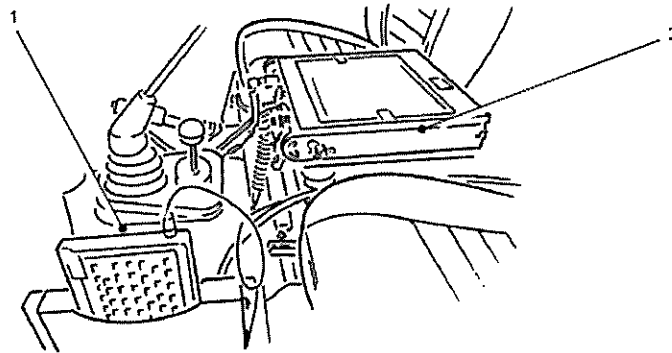

1 External keyboard 2 PUDT

Fig 37 PUDT and external keyboard

63.2 Disconnect the top right hand side cable lead from the Global Positioning System (GPS) radio receiver located in the front cab. Secure the cable to the top of the anti-roll bar with a cable tie (item 40). Remove the cable ties that secure the remaining GPS cable leads to the vehicle. Unclamp the GPS radio receiver from the vehicle with the remaining cables still connected. Stow the receiver complete with cables inside the BOWMAN waterproof bag through the front zip opening.

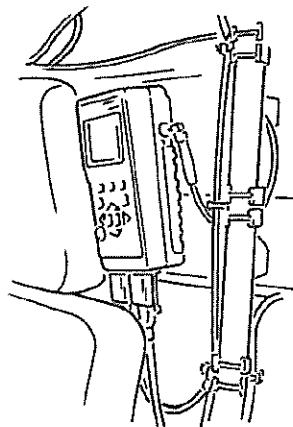

Fig 38 GPS Radio receiver

63.3 Disconnect the three cable leads fitted to the User Control Device (UCD) located in the front cab. Do not remove the UCD from the vehicle. Stow the leads inside the TUM FFR BOWMAN waterproof bag through the front zip opening. Fit the three blanking caps supplied to the UCD terminal connections.

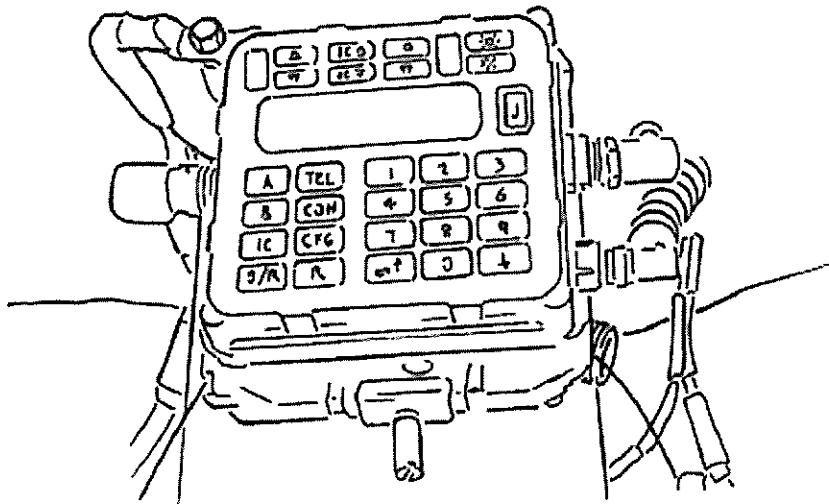
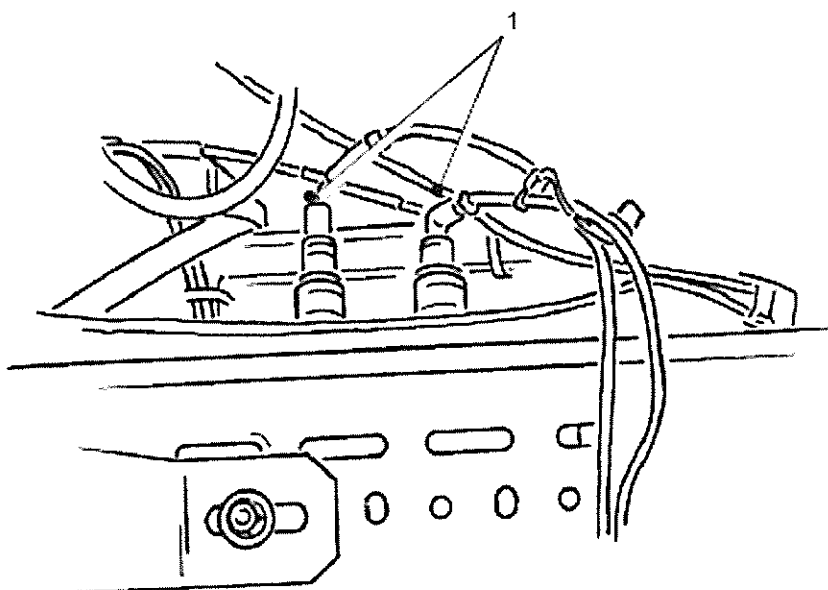

Fig 39 User Control Device

63.4 Disconnect the two Antenna cable connections from inside the front zip opening of the TUM FFR BOWMAN radio bag. Fit the blanking caps supplied to the Antenna cable connectors. Secure the cables to the top of the dexion racking with a cable tie (item 30).



1 Antenna cable connections

Fig 40 Antenna cables

63.5 Locate the loudspeaker secured to the underside of the roof in the rear of the vehicle. Disconnect the loudspeaker cable and stow inside the TUM FFR BOWMAN radio bag. Remove the loudspeaker from the vehicle and stow and secure inside the TUM FFR BOWMAN radio bag. Unclamp the loudspeaker earth lead to allow closure of the BOWMAN radio bag zip.

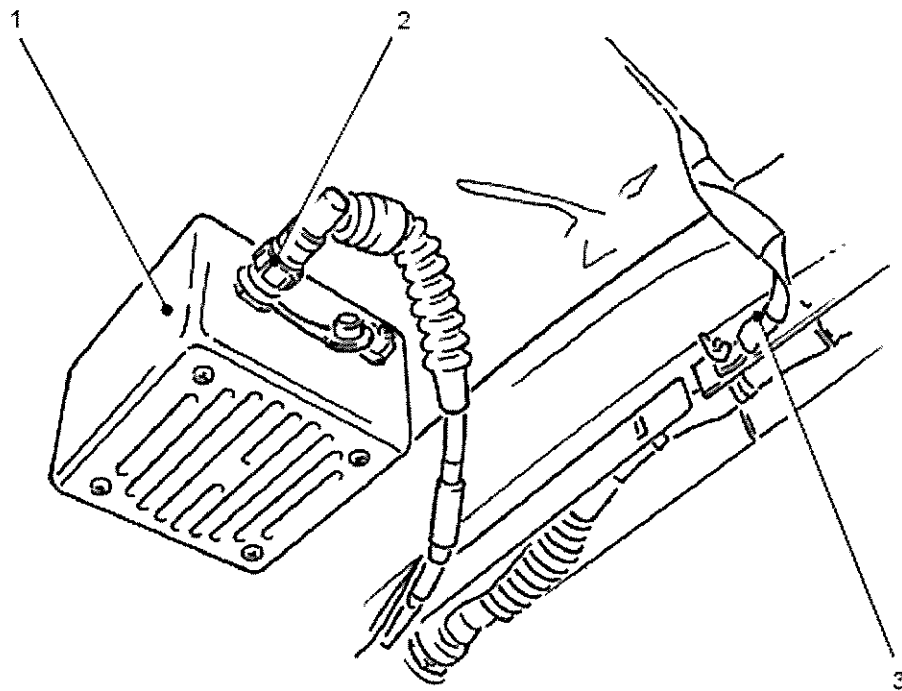

- 1 Loudspeaker 3 Loudspeaker earth lead
2 Loudspeaker cable

Fig 41 Loudspeaker

- 63.6 Ensure that all radio headsets are stowed inside the TUM FFR BOWMAN radio bag.
- 63.7 Close the front zip of the TUM FFR BOWMAN radio bag.
- 63.8 Close the rear zip of the TUM FFR BOWMAN radio bag.
- 63.9 Check and ensure that the drain plug at the rear of the TUM FFR BOWMAN radio bag is securely fitted.

TASK 27 RADIO BATTERIES (4)

WARNINGS

- (1) **NO SMOKING OR NAKED FLAMES. LEAD ACID BATTERIES PRODUCE POTENTIALLY EXPLOSIVE GASES.**
- (2) **CORROSIVE ACID ELECTROLYTE. WEAR PROTECTIVE GLOVES AND GOGGLES WHEN HANDLING BATTERIES.**

NOTES

- (1) This task to be carried out with the assistance of a radio operator.
 - (2) There are two types of battery fitted to military equipment. The early type contains electrolyte acid and have rubber filler plugs. The later type are 'Maintenance Free', Absorbive Glass Mat batteries as replacements for the originals. Both types of battery retain a venting mechanism.
- 64 Remove the battery compartment cover and slide out the battery trays. Disconnect the earth leads to gain access to the batteries.
- 64.1 Ensure that the battery breather tubing is connected correctly to each battery and that blanking caps are fitted to any unused battery breather outlets. If the blanking caps are missing or damaged, fit caps (item 12) to the breather outlets.
 - 64.2 If early type batteries are fitted, ensure that the rubber filler plugs are pushed tightly into the filler necks.
 - 64.3 Apply a coat of PX-7 grease (item 36) to the terminals of the fuse holder.
 - 64.4 Reconnect the negative earth cables to the batteries. Apply a coat of PX-7 grease to all battery terminals, ensuring that they are all completely covered.
 - 64.5 Slide in the battery trays and refit the battery compartment cover.

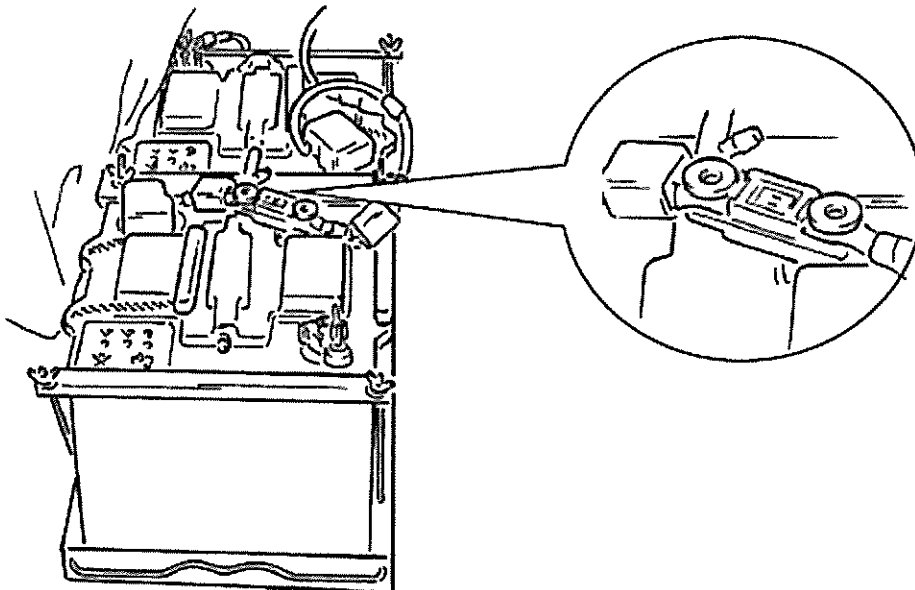

Grease PX-7

Fig 42 Radio batteries

64.6 Locate the battery breather outlets on the outside of the left hand rear body behind the passenger door. Fit a cap (item 12) over each of the two battery breather outlets.

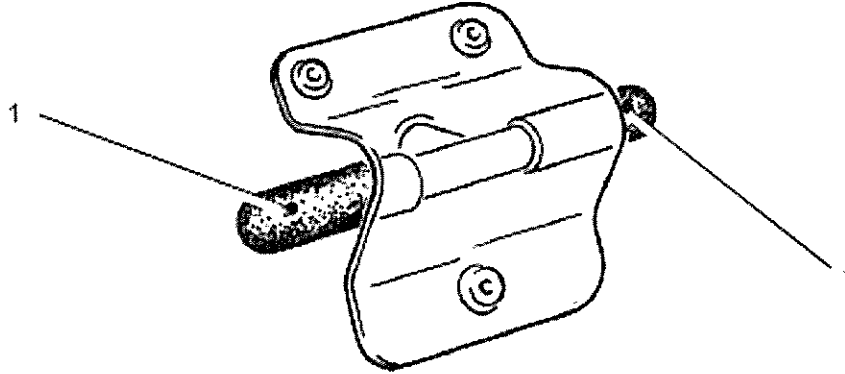

1 Cap

Fig 43 Battery breathers

TASK 28 ESCAPE HATCH

WARNING

PERSONNEL SAFETY. THE ESCAPE HATCH PROVIDES A MEANS OF ESCAPE FROM THE VEHICLE IN AN EMERGENCY. THE ESCAPE HATCH COVER MUST BE REMOVED FOR ALL FORDING OPERATIONS.

65 Disconnect the two earth bonding cables for the radiation hazard curtain from the sun visor mounting screws. Refit the sun visor securing screws. Carefully fold down and stow the front section of the curtain behind the front seats.

65.1 Release the cab roof escape hatch securing straps. Remove the cab escape hatch. Using the straps, clamp the hatch to the roof of the vehicle for safe storage.

65.2 Ensure that any items stowed on the roof do not obstruct free movement through the escape hatch.

TASK 29 PRESERVATION

66 Apply an even coat of grease XG-286 (item 35) using brush (item 28) for preservation against salt water immersion to the following:

66.1 Door hinges, door catches and key lock barrels.

66.2 Dashboard ventilator hinges.

66.3 Jerrycan stowage door hinges.

66.4 Wheel nuts.

TASK 30 REAR DOOR

67 Locate the door stay (item 11) into the door striker on the rear body.

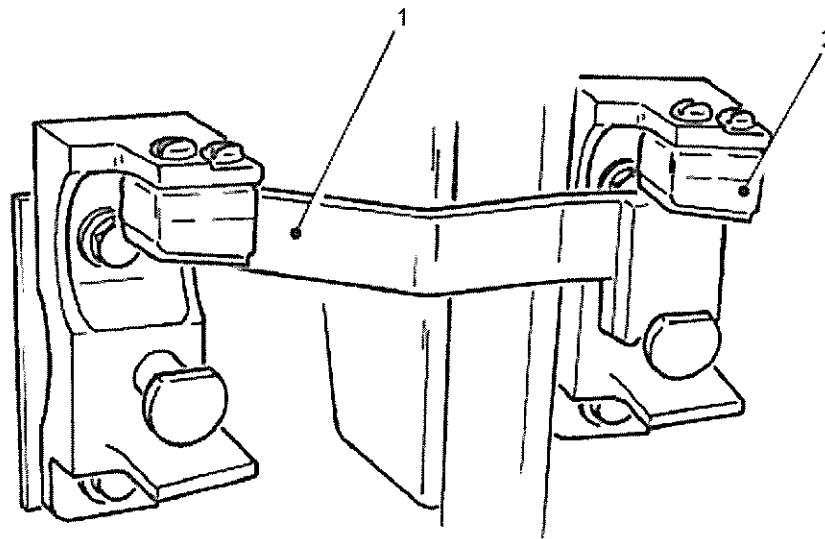

1 Door stay 2 Door striker

Fig 44 Rear body

67.1 Align the rear door lock with the door stay and securely close the door onto the stay. Ensure that the latch is fully engaged.

NOTE

The door stay is fitted to allow quick flooding of the rear body to limit the amount of vehicle flotation.

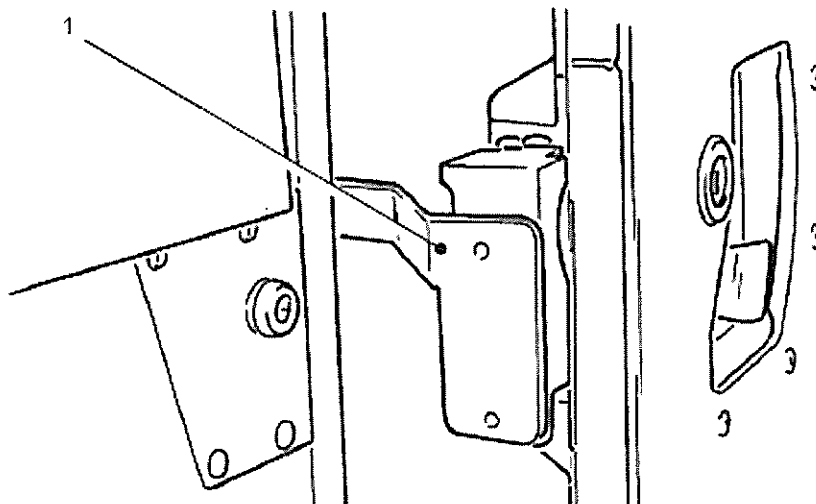

1 Door stay

Fig 45 Rear door

TASK 31 TOWROPE

68 Connect a suitable towrope to the front tow pin. Position free end of towrope up over windscreen and through escape hatch.

68.1 Tie one end of rope (item 29) to the free end of towrope. Create a suitable large knot at the other end so that it may be used as a throwing line.

TASK 32 FIRE EXTINGUISHER AND ITEMS OF EQUIPMENT

69 Remove fire extinguisher. Place extinguisher, tool roll, jack and other loose items likely to suffer damage caused by sea water immersion in one of the stowage bags (item 22). Close the zip, stow and secure the bag in a safe place on board vehicle.

TASK 33 STAGE 'B' KIT AND REMOVED ITEMS

70 Refill the spray container (item 24) with PX-24 (item 32), ensure the top is tightly secured and place in a stowage bag (item 22). It is required for de-waterproofing stages 'C' and 'D'.

70.1 Place all remaining items of the stage 'B' kit in the kit bag (item 21). Place the kit bag and all items removed at stage 'B' waterproofing in the remaining stowage bag (item 22).

TASK 34 WATERPROOFED EQUIPMENT MARKING STAGE 'B'

71 Remove the adhesive tape covering the RED stage 'B' marker on the front of vehicle (see Fig 2).

TASK 35 WATERPROOFING THE AESP

72 Read and memorize Task 36: "Driving Instructions for Prepared Fording".

72.1 Place this AESP in the stowage bag (item 22) containing the remainder of the stage 'B' kit. They will be required for de-waterproofing stages 'C' and 'D' and wet-shod re-embarkation should it be necessary.

72.2 Close the zip on the bag. Secure bag in a safe place on board vehicle.

TASK 36 DRIVING INSTRUCTIONS FOR PREPARED FORDING**CAUTIONS**

(1) **EQUIPMENT DAMAGE.** If the vehicle stalls with the engine underwater no attempt must be made to restart the engine before Drowned Vehicle Procedure (DVP) is completed.

(2) **EQUIPMENT DAMAGE.** It is essential to keep the vehicle moving through the water as 'loss of momentum' could cause failure. Do not change gear whilst in the water.

73 Engage first gear, low ratio with differential lock.

73.1 Approach ramp squarely and drive vehicle as slowly as possible down ramp. Upon entering water, depress accelerator and drive to the beach.

73.2 In the event of a vehicle failure, the driver must engage neutral gears before any recovery is attempted:

73.3 If the failure is due to loss of traction. The driver should keep the engine running during beach recovery, providing the engine air intake is clear of the water.

73.4 If the failure is due to a vehicle stall. No attempt must be made to restart the engine before Drowned Vehicle Procedure (DVP) is completed after beach recovery.

DE-WATERPROOFING STAGE 'C'

CAUTIONS

- (1) **TIME LIMITATION.** The following Tasks must be conducted within 15 minutes of leaving the water.
- (2) **DEFECT REPORTING.** All defects including occurrences of water ingress found during stage 'C' de-waterproofing, must be reported to a senior member of Unit ES staff as soon as operationally possible, for appropriate Equipment Failure Report (EFR) action.

TASK 37 ENGINE OIL LEVEL CHECK

WARNINGS

- (1) **PERSONNEL SAFETY. EXTREME CARE MUST BE TAKEN WHEN DRAINING ENGINE OIL. HOT ENGINE OIL CAN CAUSE SEVERE PERSONAL INJURY.**
- (2) **HEALTH HAZARD. PROLONGED AND REPEATED CONTACT WITH USED ENGINE OILS MAY CAUSE SERIOUS SKIN DISORDERS, INCLUDING DERMATITIS AND CANCER.**

CAUTION

OIL LEVEL. Engine must be switched off for ten minutes before any oil level check. The oil level must never be above the 'FULL' mark as engine damage may be caused.

74 Switch off engine and check engine oil level, if contaminated (emulsified), drain and refill with correct grade oil.

TASK 38 CENTRE CONSOLE

75 Remove the cover retaining strap and the cover from the centre console.

75.1 Remove the tapered plug from the console drain and check for contamination.

75.2 Stow the cover, strap, plug and the ignition switch rubber cover in the kit bag (item 21).

TASK 39 REAR DOOR

76 Remove the rear door stay and stow in the kit bag (item 21).

TASK 40 ALTERNATOR (UPPER MOUNTED) RECONNECTION

CAUTION

EQUIPMENT DAMAGE. Care must be taken to avoid short circuiting when reconnecting the radio battery cable to the terminal box. The cable connector terminals will be 'live' and must not be allowed to come into contact with any part of the vehicle bodywork.

77 Ensure engine is switched off.

77.1 At the alternator, depress the multi-plug latch and disconnect the two multi-plugs.

77.2 Locate the red and blue coloured label attached to the alternator. Connect the red multi-plug to the multi-plug blank adjacent to the red area of the label.

77.3 Connect the blue multi-plug to the multi-plug adjacent to the blue area of the label.

77.4 Disconnect the grounding harness from the FFR terminal box. Stow the harness in the kit bag (item 21).

77.5 Remove the tape securing the radio battery cable to the weapon stowage bracket. Unscrew the blanking cap from the cable connector. Reconnect the cable to the terminal box ensuring the connector is fully tightened.

77.6 Reconnect the FFR charging ECU back to its original connection.

77.7 Reconnect the dummy multi-plug back to its original connection.

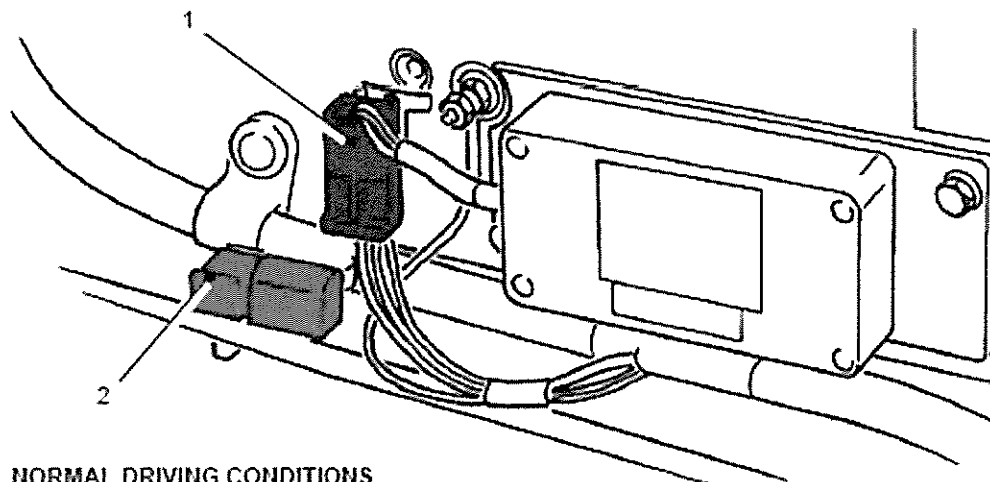

NORMAL DRIVING CONDITIONS

1 Vehicle multi-plug 2 Dummy multi-plug

Fig 46 Charging ECU connections. Normal conditions

TASK 41 ALTERNATOR (LOWER MOUNTED) RECONNECTION

78 Switch off and stop engine.

78.1 Remove the passenger seat cushion and the battery compartment cover. Disconnect the negative earth cable from the battery.

78.2 Locate the multi-plug disconnect tool attached to the left hand front wing above the windscreen washer reservoir.

78.3 Using the tool depress the multi-plug latch, applying light pressure only, disconnect the two multi-plugs.

78.4 Replace the disconnect tool to its original location.

78.5 Connect the grey multi-plugs together.

78.6 Connect the red multi-plugs together.

78.7 Reconnect battery negative cable. Do not refit battery cover, it will be refitted during the next task.

78.8 Start engine and check that the alternators are functioning correctly.

TASK 42 VEHICLE BATTERIES (2)

WARNINGS

(1) **NO SMOKING OR NAKED FLAMES. LEAD ACID BATTERIES PRODUCE POTENTIALLY EXPLOSIVE GASES.**

(2) **BATTERIES CONTAIN CORROSIVE ACID ELECTROLYTE. WEAR PROTECTIVE GLOVES AND GOGGLES WHEN HANDLING BATTERIES.**

79 Remove and discard the rubber tube from the battery vents.

79.1 Refit battery compartment cover and seat cushion.

TASK 43 FUEL TANK BREATHER

80 Depress connector latches and disconnect fuel tank breather pipe from the red colour coded pipe.

80.1 Connect fuel tank breather pipe to the blue colour coded vent pipe.

TASK 44 BRAKE FLUID RESERVOIR

81 Slacken reservoir filler cap. Remove rubber cover, tighten cap.

81.1 Depress latch and remove blanking plug from fluid level sensor multi-plug. Connect multi-plug to the fluid sensor. Stow rubber cover and blanking plug in the kit bag (item 21).

TASK 45 CLUTCH FLUID RESERVOIR

82 Remove rubber cover from clutch fluid reservoir. Stow cover in the kit bag (item 21).

TASK 46 HEATER MOTOR

83 Remove bung from motor drain tube, stow bung in the kit bag (item 21).

83.1 De-latch the multi-plugs and connect the grey multi-plugs together.

83.2 Connect the orange multi-plugs together.

TASK 47 FLYWHEEL HOUSING

84 Remove flywheel housing drain plug and check for contamination. Stow plug in the kit bag (item 21).

TASK 48 FRONT SEAT BELTS**WARNING**

PERSONNEL SAFETY. THE SEAT BELTS MUST BE REFITTED AT STAGE 'C' DE-WATERPROOFING TO MEET ROAD TRAFFIC REGULATIONS.

NOTE

This task to be carried out with the assistance of a vehicle mechanic.

85 Refit seat belts. Tighten inertia reel securing nuts to the correct torque setting (15 Nm) using the torque wrench (item 42).

85.1 Tighten the shouldered bolts securing the seat belts to the roll over cage to the correct torque setting (28-35 Nm) using the torque wrench (item 42).

85.2 Tighten the engagement/release stalk securing bolts to the correct torque setting (28-35 Nm) using the torque wrench (item 42).

TASK 49 FRONT SEATS

86 Remove the head restraints by carefully lifting from their mounting sockets.

86.1 Fit and secure a cover (item 19) over each of the front seat backrests. Refit the head restraints to the front seats.

86.2 Fit and secure a cover (item 20) over each of the front seat cushions.

NOTE

The covers are supplied to provide a waterproof barrier between the occupants and the seats.

TASK 50 REAR SEAT BELTS**WARNING**

PERSONNEL SAFETY. THE SEAT BELTS MUST BE REFITTED AT STAGE 'C' DE-WATERPROOFING TO MEET ROAD TRAFFIC REGULATIONS.

87 Refit the rear seat belts.

TASK 51 STEERING COLUMN BOX

88 Remove rubber covers from steering column box. Stow rubber covers in the kit bag (item 21).

88.1 Withdraw the switch rubber covers from the box apertures. Refit rubber covers to box.

TASK 52 FRONT WIPER

89 Remove the tapered plug from the wiper box and check for contamination. Stow the plug in the kit bag (item 21).

TASK 53 REAR WIPER

90 Remove the tapered plug from the wiper box and check for contamination. Stow the plug in the kit bag (item 21).

TASK 54 HEATER PLUGS

91 Spray PX-24 (item 33) from container (item 24) over each glow plug terminal connection to flush away any sand and salt. Stow container in the stowage bag (item 22).

TASK 55 TOWROPE

92 Remove towrope from vehicle. Stow towrope in a safe place on board vehicle.

TASK 56 ESCAPE HATCH

93 Refit the escape hatch. Refit the front section of the Radiation hazard curtain.

TASK 57 FIRE EXTINGUISHER

94 Refit fire extinguisher to vehicle.

TASK 58 NUMBER PLATE LAMP

95 Remove the rubber cover from the lamp and stow in the kit bag (item 21).

TASK 59 RADIO BATTERY BREATHERS

96 Remove and discard the caps from the battery breather outlets on the outside of the left hand rear body.

TASK 60 BOWMAN RADIO BAG AND EQUIPMENT

NOTE

This task to be carried out with the assistance of a radio operator.

97 Open up the front and rear BOWMAN radio bag zips. Roll up the rear zip cover and secure to the top of radio bag with the straps provided. Complete Para 97.1 or 97.2 depending on the type of radio bag fitted:

97.1 TUL FFR BOWMAN radio bag. Reconnect the following components removed at waterproofing stage 'B':

- 97.1.1 Automatic Antennae Coupling earth lead.
- 97.1.2 Band Pass Filter Cable.
- 97.1.3 Positive (red) and negative (black) cables to the power distribution box.
- 97.1.4 Radio Selector Box.
- 97.1.5 Personal User Data Terminal.

97.2 TUM FFR BOWMAN radio bag. Reconnect the following components removed at waterproofing stage 'B':

- 97.2.1 Loudspeaker and loudspeaker earth lead.
- 97.2.2 Antenna cables.
- 97.2.3 User Control Device.
- 97.2.4 Global Positioning System radio receiver.
- 97.2.5 Personal User Data Terminal.

TASK 61 WATERPROOFED EQUIPMENT MARKING STAGE 'C'

98 Cover the RED stage 'B' marker (see Fig 2) with black adhesive tape (item 25).

TASK 62 TEMPORARY HALT PROCEDURE

99 If a temporary halt procedure is necessary, the following precautions should be actioned:

- 99.1.1 Disconnect negative cable from battery.
- 99.1.2 Chock road wheels.
- 99.1.3 Leave the handbrake in the 'OFF' position.

WET SHOD RE-EMBARKATION

CAUTION

EQUIPMENT DAMAGE. Following completion of wet shod re-embarkation, de-waterproofing stages 'C' and 'D' must be carried out in accordance with this AESP.

SUMMARY

100 This instruction details action to be taken when the vehicle will wet shod re-embark on the landing craft after disembarking operations have been completed.

- 100.1 Check all oils for water contamination as detailed in de-waterproofing stage 'D'.
- 100.2 Carry out a thorough check of all tasks completed in waterproofing stage 'B' and rectify any damage.
- 100.3 Top up vehicle fuel tank. Refit filler cap.
- 100.4 Remove the front seat covers (items 19 and 20) and stow in the stowage bag (item 22).
- 100.5 Carry out tasks 1, 2, 3, 4, 5, 6, 7, 8, 10, 12, 13, 16, 17, 18, 19, 20, 21, 23, 24, 25, 26, 27, 28, 30, 31, 32, 33, 34, 35, and 36.

DE-WATERPROOFING STAGE 'D'**CAUTIONS**

- (1) **MILEAGE LIMITATION AFTER DISEMBARKATION.** Tasks 63, 64, 65 and 66 must be carried out after 25 miles (40 km) or 12 hours, (whichever occurs first) from point of disembarkation if operationally possible. The remaining tasks should be carried out as soon as conditions permit but within 250 miles (400 km) or 3 days, (whichever occurs first) of landing.
- (2) **WASH DOWN.** The alternators must be washed down with fresh water after Prepared Fording within three to four hours.
- (3) **DEFECT REPORTING.** All defects including occurrences of water ingress found during stage 'D' de-waterproofing, must be reported to a senior member of Unit ES staff as soon as operationally possible, for appropriate Equipment Failure Report (EFR) action.

TASK 63 OIL CONTAMINATION CHECK**WARNINGS**

- (1) **PERSONNEL SAFETY. EXTREME CARE MUST BE TAKEN WHEN DRAINING ENGINE OIL. HOT ENGINE OIL CAN CAUSE SEVERE PERSONAL INJURY.**
- (2) **HEALTH HAZARD. PROLONGED AND REPEATED CONTACT WITH USED ENGINE OILS MAY CAUSE SERIOUS SKIN DISORDERS, INCLUDING DERMATITIS AND CANCER.**

CAUTION

OIL LEVEL. Engine must be switched off for ten minutes before any oil level check. The oil level must never be above the 'FULL' mark as engine damage may be caused.

101 Check all oil levels. If water is present (emulsified), in any assembly:

- 101.1 Drain oil.
- 101.2 Refill with correct grade lubricant.

TASK 64 CLUTCH AND BRAKES

102 To prevent seizure of clutch and brakes when parked, every opportunity should be taken to:

- 102.1 Prop out clutch pedal with a suitable prop.
- 102.2 Chock road wheels and leave the handbrake in the 'OFF' position.

TASK 65 WASH DOWN**WARNING**

PERSONNEL SAFETY. THE SEAT BELTS AND FRONT SEAT HEAD RESTRAINTS MUST BE REFITTED FOLLOWING THE WASH DOWN, TO MEET ROAD TRAFFIC REGULATIONS.

CAUTION

EQUIPMENT DAMAGE. Water entering the engine air intake system will cause major failure when the engine is restarted. Do not direct the wash down hose at the high level air intake or allow water to enter the intake system. Avoid prolonged hosing of electrical equipment.

NOTE

This task to be carried out with the assistance of a vehicle mechanic.

103 It is important that the correct wash down procedures is observed.

103.1 The following guidelines must be adhered to when washing down the vehicle to avoid damage to the wax protective coating:

103.1.1 Cold water pressure washing is preferred. In any event, water temperature should not exceed 60 degrees C.

103.1.2 Pressure of water should not exceed 1200 PSI.

103.1.3 Ensure a distance of approximately 30 cm between the nozzle lance and the surface being washed.

103.1.4 No detergent is to be used.

103.2 Remove the passenger seat cushion and the battery compartment cover. Disconnect the negative cable from the battery.

103.3 Carry out stage 'B' waterproofing tasks 3, 6, 7, 13, 16, 17, 18, 19, 23, 25 and 26.

103.4 Remove the fire extinguisher, front seat head restraints, front seat covers (items 19 and 20) and any loose items of equipment from the vehicle, that would be likely to suffer damage during wash down.

103.5 Wash down the entire vehicle thoroughly with freshwater. Remove all traces of sand and salt deposits. Ensure the following areas are included:

103.5.1 Engine and all under bonnet areas.

103.5.2 Cab and rear cargo body.

103.5.3 Jerrycan stowage compartments.

103.5.4 Radio battery compartment.

103.5.5 Top of fuel tank and tank filler neck compartment.

103.6 Carry out stage 'C' de-waterproofing tasks 38, 44, 45, 48, 49, 50, 51, 52, 53 and 60.

103.7 Reconnect the negative cable to the battery. Refit battery compartment cover and passenger seat cushion.

103.8 Refit the front seat head restraints, fire extinguisher and loose items of equipment.

TASK 66 LOWER MOUNTED ALTERNATOR BREATHER

WARNING

HEAT INJURY HAZARD. EXHAUST COMPONENTS WILL BECOME VERY HOT WHEN THE ENGINE IS RUNNING. IN ORDER TO PREVENT THE POSSIBILITY OF SEVERE PERSONAL INJURY, ADEQUATE TIME MUST BE ALLOWED FOR THE SYSTEM TO COOL BEFORE ANY WORK IS UNDERTAKEN IN THE VICINITY OF THE EXHAUST MANIFOLD.

NOTES

(1) This task to be carried out with the assistance of a vehicle mechanic.

- (2) The breather is located on the underside of the alternator end cover. Access is difficult and care must be taken not to damage any of the intercooler pipes.

104 Refit the alternator breather hose and secure with the original wing screw clamp.

TASK 67 WEBASTO HEATER

NOTE

This task to be carried out with the assistance of a vehicle mechanic.

105 Flush the exhaust system through with freshwater. Take care that no other vehicle systems are contaminated with water.

105.1 Remove the caps from the intake and exhaust pipes. Stow the caps and the exhaust cap clamp in the kit bag (item 21).

105.2 Install the connection sleeve and refit the exhaust to the heater. Ensure clearance between the Webasto exhaust and the engine turbocharger.

105.3 Refit the intake pipe to the heater and secure with its original clamp. Ensure the pipe is fitted through its support clip and the open end is facing downward.

105.4 Spray an even coat of PX-24 (item 33) from container (item 24) over the heater to wash off any sand or salt deposits.

105.5 Remove the cap from the Webasto control box drain valve. Depress the valve core and check for water ingress. If water is present, test control box in accordance with AESP 2320-D-128-522 Chap 13-5.

105.6 Refit the heater switch knob.

105.7 Operate heater for fifteen minutes for drying out purposes and to check that it is functioning correctly.

TASK 68 HEATER CONTROL CABLES

NOTE

This task to be carried out with the assistance of a vehicle mechanic.

106 Referring to AESP 2320-D-128-522 Chap 18, service the three heater control cables.

106.1 Ensure correct operation of all control cables.

TASK 69 FRONT SEATS

WARNING

HEALTH HAZARD. BEFORE THE COMMENCEMENT OF ANY PAINTING, REFER TO AESP 0200-A-221-013, 'PAINTING OF SERVICE EQUIPMENT' AND THE RELEVANT COSHH REGULATIONS FOR THE MATERIAL.

NOTES

- (1) This task to be carried out with the assistance of a vehicle mechanic.
- (2) Do not allow any fluids or oils to contaminate the seat upholstery.

107 Remove front seats and runners. Remove the seat covers (items 19 and 20). Lift off the backrest adjustment lever cover.

107.1 Wash off the seat runners and the backrest adjustment mechanisms with PX-24 (item 33) using spray container (item 24). Remove all traces of sand and salt deposits.

107.2 Restore any damaged paint finish to the seats.

107.3 Lightly lubricate all seat moving parts with OMD 90 oil.

107.4 Refit the backrest adjustment lever covers.

107.5 Refit front seats and runners.

107.6 Refit the seat covers if required. If the seats have dried sufficiently and the covers are not required, place covers in the stowage bag (item 22).

TASK 70 DOOR LOCKS AND HINGES

NOTE

This task to be carried out with the assistance of a vehicle mechanic.

108 Remove all door locks. Wash out lock mechanisms and key lock barrels with PX-24 (item 33) using the spray container (item 24). Ensure all traces of sand and salt deposits are removed.

108.1 Lubricate all moving parts with OMD 90 oil ensuring smooth operation of key lock barrels.

108.2 Refit all door locks.

108.3 Wash off all hinges including jerrycan stowage and dashboard ventilators with PX-24 (item 33) using the spray container (item 24). Ensure all traces of sand and salt deposits are removed.

108.4 Lubricate all hinges with OMD 90 oil.

TASK 71 HUBS AND BRAKES

WARNINGS

(1) HEALTH HAZARD. BEFORE THE COMMENCEMENT OF ANY PAINTING, REFER TO AESP 0200-A-221-013, 'PAINTING OF SERVICE EQUIPMENT' AND THE RELEVANT COSHH REGULATIONS FOR THE MATERIAL.

(2) SAFETY. DO NOT ALLOW ANY PAINT TO CONTAMINATE THE BRAKE LININGS OR THE FRICTION SURFACES OF THE BRAKE DRUM.

NOTE

This task to be carried out with the assistance of a vehicle mechanic.

109 Strip and service all wheel hubs ensuring that the hub oil seals are renewed (refer to AESP 2320-D-128-522 Chap 5 and 6). Wash off stub axles with PX-24 (item 33) using the spray container (item 24) to remove all traces of sand and salt deposits.

109.1 Ensure serviceability of brake pads and callipers before reassembly (refer to AESP 2320-D- 128-522 Chap 10).

109.2 Strip and service the transmission brake (refer to AESP 2320-D-128-522 Chap 10). Wash off the oil seal area of the transfer box drive flange with PX-24 (item 33) using the spray container (item 24). Ensure all traces of sand and salt deposits are removed.

109.3 Prior to reassembly, paint the following items with red oxide NSN H1 8010-99-910-6645 for protection. Do not contaminate brake linings or friction surface areas of the brake drum with paint.

109.3.1 Brake shoes.

109.3.2 Brake back plate.

109.3.3 Brake drum.

109.4 Lubricate the handbrake ratchet pawl linkage with OMD 90 oil.

TASK 72 CLUTCH

110 Lightly lubricate the clutch pedal linkage with OMD 90 oil.

TASK 73 STOWAGE COMPARTMENTS

WARNING

HEALTH HAZARD. BEFORE THE COMMENCEMENT OF ANY PAINTING, REFER TO AESP 0200-A-221-013, 'PAINTING OF SERVICE EQUIPMENT' AND THE RELEVANT COSHH REGULATIONS FOR THE MATERIAL.

111 Remove all traces of sand and salt deposits from the jerrycan stowage compartment.

111.1 Remove all traces of sand and salt deposits from the stowage compartment located under the front seat on the TUM variant.

111.2 Restore any damaged paint finish to the jerrycan and under seat stowage compartments.

TASK 74 VEHICLE BATTERY COMPARTMENT

WARNINGS

(1) **NO SMOKING OR NAKED FLAMES. LEAD ACID BATTERIES PRODUCE POTENTIALLY EXPLOSIVE GASES.**

(2) **BATTERIES CONTAIN CORROSIVE ACID ELECTROLYTE. WEAR PROTECTIVE GLOVES AND GOGGLES WHEN HANDLING BATTERIES.**

(3) **HEALTH HAZARD. BEFORE THE COMMENCEMENT OF ANY PAINTING, REFER TO AESP 0200-A-221-013, 'PAINTING OF SERVICE EQUIPMENT' AND THE RELEVANT COSHH REGULATIONS FOR THE MATERIAL.**

NOTE

This task to be carried out with the assistance of a vehicle mechanic.

112 Remove passenger seat cushion and the battery compartment cover. Disconnect and remove the batteries. Undo the fixings and remove the battery trays.

112.1 Remove all traces of sand and salt deposits from the battery compartment and the battery trays. Allow the compartment to completely dry out.

112.2 Restore any damaged paint finish to the battery compartment and the battery trays.

112.3 Refit the battery trays.

112.4 Clean the battery casings. Refit and reconnect the batteries. Apply a coat of PX-7 grease (item 36) to the terminals.

112.5 Refit battery compartment cover and the seat cushion.

112.6 From under the vehicle, apply a coat of 'Dinol' wax to the battery tray fixings to preserve the underbody wax protection (refer to AESP 2320-D-128-522 Chap 16).

TASK 75 RADIO BATTERY COMPARTMENT

WARNINGS

(1) **NO SMOKING OR NAKED FLAMES. LEAD ACID BATTERIES PRODUCE POTENTIALLY EXPLOSIVE GASES.**

(2) **BATTERIES CONTAIN CORROSIVE ACID ELECTROLYTE. WEAR PROTECTIVE GLOVES AND GOGGLES WHEN HANDLING BATTERIES.**

(3) **HEALTH HAZARD. BEFORE THE COMMENCEMENT OF ANY PAINTING, REFER TO AESP 0200-A-221-013, 'PAINTING OF SERVICE EQUIPMENT' AND THE RELEVANT COSHH REGULATIONS FOR THE MATERIAL.**

NOTE

This task to be carried out with the assistance of a radio operator.

113 Remove battery compartment cover and slide out the battery trays. Disconnect and remove the batteries and trays.

113.1 Remove all traces of sand and salt deposits from the battery compartment. Allow the compartment to completely dry out.

113.2 Restore any damaged paint finish to the battery compartment.

113.3 Clean the battery casings. Refit and reconnect the batteries. Apply a coat of PX-7 grease (item 36) to the terminals.

113.4 Reconnect the battery breather tubing and ensure that blanking caps are fitted to all unused battery breather outlets.

113.5 Slide in the battery trays and refit the battery compartment cover.

TASK 76 FLOOR COVERINGS

WARNING

HEALTH HAZARD. BEFORE THE COMMENCEMENT OF ANY PAINTING, REFER TO AESP 0200-A-221-013, 'PAINTING OF SERVICE EQUIPMENT' AND THE RELEVANT COSHH REGULATIONS FOR THE MATERIAL.

114 Remove the floor mats from the driver's cab and the rear cargo body. From inside the rear body, remove the heater pipe protection cover attached to the rear bulkhead.

114.1 Remove all traces of sand and salt deposits from the cab and rear cargo body areas. Allow the floors to completely dry out.

114.2 Restore any damaged paint finish to the driver's and rear cargo body.

114.3 Wash off the floor mats with freshwater and allow to dry.

114.4 Refit the heater pipe protection cover to the rear bulkhead.

114.5 Refit the floor mats.

TASK 77 NATO 12 PIN TOWING SOCKET

115 Remove all traces of silicone compound from the towing socket.

TASK 78 DELETED

116 Deleted.

TASK 79 COMPONENT BREATHER SYSTEM DRAIN

NOTES

(1) This task to be carried out with the assistance of a vehicle mechanic.

(2) The drain tube is located under at the rear of the right hand front wheel arch, above the chassis outrigger. Access is gained beneath the right hand front wing.

117 Release the hose clamp, remove the plug and drain any contamination. Refit the plug and tighten the clamp.

117.1 If contamination is more than could be expected from condensation, the cause must be investigated and rectified.

TASK 80 REAR VIEW MIRRORS-DOOR MOUNTED

118 Prise the plastic caps from the mirror head adjustment. Wash off the adjustment screws and washer with PX-24 (item 33) using the spray container (item 24). Refit the plastic caps.

TASK 81 FRONT AND REAR LIGHTS

119 Examine front and rear lights for contamination. If contamination is present in any light:

119.1 Remove and drain light.

119.2 Wash out light in freshwater and dry off thoroughly.

119.3 Refit light (refer to AESP 2320-D-128-201 Chap 4-1).

TASK 82 GEAR LEVER HOUSING

NOTES

(1) This task to be carried out with the assistance of a vehicle mechanic.

(2) It will be necessary to demand the replacement parts required for this task.

120 Remove gear lever housing and check for contamination. Remove any traces of contamination from the lever housing and the remote housing.

120.1 Refit lever housing (refer to AESP 2320-D-128-523) using the following replacement parts:

120.1.1 Gear lever grommet.

120.1.2 Grommet cable tie.

120.1.3 Housing gasket.

TASK 83 TRANSFER GEARBOX SELECTOR HOUSING

NOTES

- (1) This task to be carried out with the assistance of a vehicle mechanic.
- (2) It will be necessary to demand the replacement parts required for this task.

121 Remove transfer gearbox lever grommet and check housing for contamination. Remove any traces of contamination from the housing.

121.1 Renew the transfer lever grommet (refer to AESP 2320-D-128-523) and assemble using the following replacement parts:

- 121.1.1 Grommet cable tie.
- 121.1.2 Grommet support plate.
- 121.1.3 Gasket.

TASK 84 PROPELLER SHAFTS

122 Grease gun lubricate all propeller shaft joints to expel any sea water (refer to AESP 2320-D-128-601, Table 7).

TASK 85 LUBRICATION AND MAINTENANCE

NOTE

This task to be carried out with the assistance of a vehicle mechanic.

123 Complete the 6000 miles (10000 km) maintenance schedule (refer to AESP 2320-D-128-601, Table 7).

TASK 86 ENGINE CONTROLS

NOTE

This task to be carried out with the assistance of a vehicle mechanic.

124 Lubricate the engine controls with OMD 90 oil and ensure correct operation.

TASK 87 REAR TOW PINTLE

NOTE

This task to be carried out with the assistance of a vehicle mechanic.

125 Service and ensure correct operation of the tow pintle (refer to AESP 2320-D-128-601, Table 7).

TASK 88 FRONT SEAT BELTS

WARNING

PROCEDURE. TO MAINTAIN THE INTEGRITY OF SEAT BELT TORQUE SETTING, THE SECURING BOLTS MUST BE REPLACED AT STAGE 'D' DE-WATERPROOFING.

NOTE

This task to be carried out with the assistance of a vehicle mechanic.

126 Remove and discard the two bolts securing the seat belts to the roll over cage. Refit the seat belts using the two shouldered patchlock bolts supplied in the seat belt fixing kit (item 40). Tighten the bolts to the correct torque setting (28-35 Nm) using the torque wrench (item 42).

126.1 Remove and discard the two bolts securing the seat belt anchorage/release stalks to the body. Refit the stalks using the two bolts and two lock washers supplied in the seat belt fixing kit (item 40). Tighten the bolts to the correct torque setting (28-35 Nm) using the torque wrench (item 42).

126.2 Remove and discard the nuts and washers securing the two inertia reel units to the floor. Refit the inertia reel units using the nuts and washers supplied in the seat belt fixing kit (item 40). Tighten the nuts to the correct torque setting (15 Nm) using the torque wrench (item 42).

TASK 89 FUTURE WATERPROOFING REQUIREMENTS

127 Examine the content and condition of the stage 'B' waterproofing kit. Re-demand replacement items, detailed in Parts List at Para 11, as necessary for future waterproofing use.

TABLE 2 WATERPROOFING TASK CHECK LIST TRUCK UTILITY LIGHT (HS) FFR AND TRUCK UTILITY MEDIUM (HS) FFR

VEHICLE NO.

Page No. (1)	Para No. (2)	Item (3)	Initialed Completed (4)
15	-	WATERPROOFING STAGE 'B'	
15	37	Sequence of operations	
15	38	Task 1 Vehicle batteries	
15	39	Task 2 Radio batteries (4)	
16	40	Task 3 Engine air cleaner	
17	41	Task 4 Alternator (upper mounted)	
20	42	Task 5 Alternator (lower mounted)	
21	43	Task 6 Clutch fluid reservoir	
22	44	Task 7 Brake fluid reservoir	
24	45	Task 8 Heater plugs	
24	46	Task 9 Windscreen washer reservoir	
25	47	Task 10 Fuel tank breather	
26	48	Task 11 Webasto heater	
28	49	Task 12 Heater	
29	50	Task 13 Steering column switches	
29	51	Task 14 Deleted	
30	52	Task 15 Inter-vehicle start socket	
30	53	Task 16 Front wiper motor	
31	54	Task 17 Front seat belts	
31	55	Task 18 Rear seat belts	
31	56	Task 19 Rear wiper motor	
32	57	Task 20 Flywheel housing	
32	58	Task 21 Number plate lamp	
33	59	Task 22 NATO 12 pin towing socket	
34	60	Task 23 Centre console	
37	61	Task 24 Batteries (2)	
38	62	Task 25 TUL FFR BOWMAN Radio bag	
40	63	Task 26 TUM FFR BOWMAN Radio bag	
43	64	Task 27 Radio batteries (4)	
44	65	Task 28 Escape hatch	
44	66	Task 29 Preservation	
45	67	Task 30 Rear door	
46	68	Task 31 Towrope	
46	69	Task 32 Fire extinguisher and items of equipment	
46	70	Task 33 Stage 'B' kit and removed items	

(continued)

**TABLE 2 WATERPROOFING TASK CHECK LIST TRUCK UTILITY LIGHT (HS) FFR AND
TRUCK UTILITY MEDIUM (HS) FFR (continued)**

VEHICLE NO.

Page No. (1)	Para No. (2)	Item (3)	Initialled Completed (4)
15	-	WATERPROOFING STAGE 'B' (continued)	
46	71	Task 34 Waterproofed equipment marking stage 'B'	
46	72	Task 35 Waterproofing the AESP	
46	73	Task 36 Driving instructions for 'Prepared Fording'	
47		DE-WATERPROOFING STAGE 'C'	
47	74	Task 37 Engine oil level check	
47	75	Task 38 Centre console	
47	76	Task 39 Rear door	
47	77	Task 40 Alternator (upper mounted) reconnection	
48	78	Task 41 Alternator (lower mounted) reconnection	
49	79	Task 42 Vehicle batteries (2)	
49	80	Task 43 Fuel tank breather	
49	81	Task 44 Brake fluid reservoir	
49	82	Task 45 Clutch fluid reservoir	
49	83	Task 46 Heater motor	
49	84	Task 47 Flywheel housing	
50	85	Task 48 Front seat belts	
50	86	Task 49 Front seats	
50	87	Task 50 Rear seat belts	
50	88	Task 51 Steering column box	
50	89	Task 52 Front wiper	
50	90	Task 53 Rear wiper	
51	91	Task 54 Heater plugs	
51	92	Task 55 Towrope	
51	93	Task 56 Escape hatch	
51	94	Task 57 Fire extinguisher	
51	95	Task 58 Number plate lamp	
51	96	Task 59 Radio battery breathers	
51	97	Task 60 BOWMAN Radio bag and equipment	
52	98	Task 61 Waterproofed equipment marking stage 'C'	
52	99	Task 62 Temporary halt procedure	
53	-	WET SHOD RE-EMBARKATION	
53	100	Summary	
54	-	DE-WATERPROOFING STAGE 'D'	
54	101	Task 63 Oil contamination check	

(continued)

TABLE 2 WATERPROOFING TASK CHECK LIST TRUCK UTILITY LIGHT (HS) FFR AND TRUCK UTILITY MEDIUM (HS) FFR (continued)

VEHICLE NO.

Page No. (1)	Para No. (2)	Item (3)	Initialled Completed (4)
54	-	DE-WATERPROOFING STAGE 'D' (continued)	
54	102	Task 64 Clutch and brakes	
55	103	Task 65 Wash down	
56	104	Task 66 Lower mounted alternator breather	
56	105	Task 67 Webasto heater	
56	106	Task 68 Heater control cables	
57	107	Task 69 Front seats	
57	108	Task 70 Door locks and hinges	
57	109	Task 71 Hubs and brakes	
58	110	Task 72 Clutch	
58	111	Task 73 Stowage compartments	
58	112	Task 74 Vehicle battery compartment	
59	113	Task 75 Radio battery compartment	
59	114	Task 76 Floor coverings	
60	115	Task 77 NATO 12 pin towing socket	
60	116	Task 78 Deleted	
60	117	Task 79 Component breather system drain	
60	118	Task 80 Rear view mirrors - door mounted	
60	119	Task 81 Front and rear lights	
60	120	Task 82 Gear lever housing	
61	121	Task 83 Transfer gearbox selector housing	
61	122	Task 84 Propeller shafts	
61	123	Task 85 Lubrication and maintenance	
61	124	Task 86 Engine controls	
61	125	Task 87 Rear tow pintle	
62	126	Task 88 Front seat belts	
62	127	Task 89 Future Waterproofing requirements	

PAGE LEFT INTENTIONALLY BLANK

TRUCK UTILITY MEDIUM (TUM) AMBULANCE HS (WATERPROOFED VARIANTS ONLY)

CODE NB 1048 3100

PREPARATION FOR SPECIAL ENVIRONMENT INSTRUCTION NO. 3

WATERPROOFING INSTRUCTIONS AMBULANCE HS VARIANTS

CONTENTS

Sponsor: OSVP PT
Project number: ES52C/4356
File ref: LVG
Publication agency: OSVP PT, DE&S Abbey Wood

AMENDMENT RECORD

Amdt No.	Incorporated By (Signature)	Date
1		
2		
3		

Amdt No.	Incorporated By (Signature)	Date
4		
5		
6		

SUBJECT: Waterproofing instructions Stage 'B'

CONTENTS

Para

- 1 Introduction (WARNING) (CAUTIONS)
- 3 Waterproofing stage 'B'
- 4 De-waterproofing stage 'C'
- 5 De-waterproofing stage 'D'
- 6 Associated publications
- 7 Stores required
- 11 Stores, tools and equipment (WARNING)
- 12 General instructions
- 17 Materials, uses and application (WARNING)
- 22 Waterproofing arrangements
- 23 Checking the waterproofing kit
- 24 Preparatory servicing (CAUTIONS)
- 25 Component Location
- WATERPROOFING STAGE 'B'
- 26 Sequence of operations
- 27 Task 1 Batteries (WARNINGS)
- 28 Task 2 Engine air Cleaner (CAUTION)
- 29 Task 3 Alternator (CAUTION)

(continued)

CONTENTS (continued)

Para

30	Task 4 Windscreen washer reservoir (WARNING) (CAUTION)
31	Task 5 Heater plugs
32	Task 6 Fuel tank breather
33	Task 7 Webasto heater
34	Task 8 Heater
35	Task 9 Inter-vehicle start socket
36	Task 10 Flywheel housing
37	Task 11 Eberspacher rear body heater
38	Task 12 Batteries (2) (WARNINGS)
39	Task 13 Preservation
40	Task 14 Towrope
41	Task 15 Stage 'B' kit and items of equipment
42	Task 16 Escape procedure) (WARNING)
43	Task 17 Waterproofing the AESP
44	Task 18 Driving instructions for deep fording (WARNING) (CAUTIONS) DE-WATERPROOFING STAGE 'C' (CAUTIONS)
45	Task 19 Engine oil level (WARNINGS) (CAUTION)
46	Task 20 Alternator reconnection
47	Task 21 Fuel tank breather
48	Task 22 Heater motor
49	Task 23 Flywheel housing
50	Task 24 Heater plugs
51	Task 25 Towrope
52	Task 26 Removable rear windows
53	Task 27 Temporary halt procedure DE-WATERPROOFING STAGE 'D') (CAUTIONS)
54	Task 28 Oil change (WARNINGS)
55	Task 29 Clutch and brakes
56	Task 30 Alternator breather (WARNING)
57	Task 31 Wash down (CAUTIONS)
58	Task 32 Webasto Heater
59	Task 33 Eberspacher Rear Body Heater
60	Task 34 Hubs and brakes (WARNINGS)
61	Task 35 Stowage compartments (WARNING)
62	Task 36 Battery compartment (WARNINGS)
63	Task 37 Floor coverings (WARNING)
64	Task 38 Component breather system drain
65	Task 39 Front and rear lights
66	Task 40 Propeller shafts)
67	Task 41 Lubrication and maintenance
68	Task 42 Engine controls
69	Task 43 Future waterproofing requirements

Table

Page

1	Man hour content	5
2	Waterproofing task check list	32

Fig

Page

1	Component layout	9
2	Air cleaner	11
3	Alternator disconnection	12

(continued)

CONTENTS (continued)

Fig		Page
4	Alternator breather hose.....	12
5	Heater plugs	13
6	Fuel tank breather	14
7	Webasto heater	15
8	Webasto caps.....	16
9	Webasto switch	16
10	Heater multi-plugs	17
11	Motor drain	17
12	Inter-vehicle start socket	18
13	Flywheel housing.....	18
14	Eberspacher heater.....	19
15	Eberspacher switch.....	20
16	Ventilator grille.....	20
17	Rear window.....	22

INTRODUCTION**WARNING**

PERSONNEL SAFETY. THE MAXIMUM SPECIFIED FORDING DEPTH FOR THIS EQUIPMENT IS 0.6 METRES AND MUST NOT BE EXCEEDED UNDER ANY CIRCUMSTANCES. THE EQUIPMENT IS SUBJECT TO FLOTATION AT DEPTHS APPROACHING 1 METRE. UNDER CERTAIN CONDITIONS FLOTATION COULD CAUSE THE EQUIPMENT TO TIP OVER OR DRIFT AWAY.

CAUTIONS

(1) EQUIPMENT DAMAGE. Only waterproofed variants with the Equipment Asset Code (EAC) listed on Page 1 are to be implemented with this instruction. The vehicle must not be forded until the stage 'B' kit is fitted as instructed in this AESP.

(2) VEHICLE RECORD BOOK. This instruction AESP 2320-D-128-421 must be retained with the vehicle record book.

1 This instruction details the method of waterproofing to enable the vehicle to ford through an effective depth of 0.6 metres including entry/exit angles, wheel sink and wave height. The waterproofing when applied will enable the vehicle to ford with the minimum of preparation for six minutes. To enable the vehicle to achieve this objective, a Special Environment Waterproofing kit is fitted.

2 Where variations from standard occur on the vehicle or equipment due to modifications or contract changes, advice and direction of the unit Motor Transport Officer (MTO) should be sought regarding additional or amended tasks.

Waterproofing stage 'B'

3 The modification kit NSN 7XDW 2540 99 481 9231 is fitted prior to deep fording. The maximum time allowed to complete this stage is two hours. This will permit the vehicle to ford through an effective depth of 0.6 metres of fresh or sea water for 6 minutes duration. On completion of this stage pre-ford running time should be restricted to 15 minutes. Post ford mileage must conform to stages 'C' and 'D'.

De-waterproofing stage 'C'

4 The tasks in this stage can be completed in a few minutes and must be conducted within 15 minutes of leaving the water.

De-waterproofing stage 'D'

5 Tasks in this stage are dependent on operational conditions. Certain tasks may need to be carried out within 25 miles (40 Km) or 12 hours from the point of disembarkation. The remaining tasks should be carried out as soon as conditions permit but within 250 miles (400 Km) or 3 days of landing.

NOTE

Vehicle mechanic assistance will be required for Tasks 2, 3, 7, 11, 30, 32, 33, 34, 36, 38, 41 and 42.

Associated publications

- 6 Refer to Army Equipment Support Publication (AESP):
 - 6.1 2320-D-128-201 Operating Information
 - 6.2 2320-D-128-522 Maintenance Instructions
 - 6.3 2320-D-128-523 Repair Instructions
 - 6.4 2320-D-128-601 Maintenance Schedules
 - 6.5 2300-A-600-013 Waterproofing Regulations - Vehicles and Equipment

STORES REQUIRED

7 Items for waterproofing kits are MOD controlled stores. Operationally they are issued without demand. Should issue be authorized for training purposes:

- 7.1 In the UK they are to be demanded from the Ministry of Defence DSM (A) Control Division, Bicester, through district headquarters.
- 7.2 Overseas, they are to be demanded through formation or district headquarters.

8 When a complete stage 'B' kit is required, the full Army designation of the vehicle or equipment including code number and contract number is to be stated on the demand. Authority for issue must be quoted.

9 Normally, individual items are not issued separately but may be demanded to make good kit deficiencies. Such demands are to quote full part numbers and designations as shown in this waterproofing instruction Para 11.1. A brief explanation of circumstances necessitating the demand is to be attached.

10 Inflammable items, which have a shelf storage life, are listed at Para 11.2 of the kit list. These items are to be demanded separately by units prior to undertaking the fitting of waterproofing kits.

TABLE 1 MAN HOUR CONTENT

Serial (1)	Detail (2)	Approximate time in man-hours		Maximum No. of men who can be usefully employed (5)	Maximum time required hours (6)
		Crew Dvr (3)	Veh Mech (4)		
1	Perusal of this AESP and checking of Waterproofing kit against kit list	2	-	2	1
2	Servicing of equipment	5	1	2	5
3	Waterproofing stage 'B'	0.33	0.2	2	0.33
4	De-waterproofing stage 'C'	0.11	-	3	0.05
5	De-waterproofing stage 'D'	2.5	6	2	8.5

STORES, TOOLS AND EQUIPMENT

WARNING

HEALTH AND SAFETY. MATERIALS USED IN WATERPROOFING ARE REQUIRED TO MEET OBLIGATIONS INTRODUCED UNDER THE CONTROL OF SUBSTANCES HAZARDOUS TO HEALTH REGULATIONS 1994 (COSHH). SAFETY INFORMATION RELATING TO MATERIALS USED IS CONTAINED IN JSP (F) 395-CATALOGUE OF HAZARDOUS STORES.

11 Stores to be demanded.

11.1 The following modification items are to be demanded quoting this instruction as authority for demand:

Item No. (1)	DMC (2)	NSN/Part No. (3)	Designation (4)	Qty per veh (5)
	7XDW	2540 99 481 9231	Special environment waterproofing kit (WPG 9746B) Truck Utility Medium (TUM) Ambulance HS (STC 4604) consisting:	
1	AESP	2320-D-128-421	Waterproofing instruction No. 1 (VDX 100850)	(1)
2	7XDW	5340-99-573-6328	Cap, Webasto intake (IPK 100140)	(2)*
3	7XDW	5340-99-573-6327	Cap, Webasto exhaust (IPK 100130)	(2)*
4	6MT1	4730-99-533-2966	Clamp, Webasto (CN100508L)	(1)
5	7XDW	5340-99-573-6445	Cap, protective (RRC 5110)	(2)*
6	7XRU	5365-99-732-7008	Plug, flywheel housing (ERC 7295)	(1)
7	7XDW	5340-99-905-8420	Cap, Eberspacher (STC 4605)	(4)*
8	6MT1	4730-99-798-0799	Clamp, Eberspacher (CN 100308L)	(2)
9	7RU	5340-99-829-4908	Cable tie (594594)	(2)*
10	7XDW	8105-99-806-3294	Bag, stage 'B' kit (STC 4606)	(1)
11	H10	7930-99-244-6936	Container, spray (IRE 100000)	(1)
12	F1	8020-99-943-0417	Brush, artist's flat fitch No. 2 (IRX 100000)	(1)
13	F1	8020-99-125-5009	Brush 1 in. wide (IRX 100010)	(1)
14	H21	4020-99-942-5038	Rope, fibrous (IRY 100000)	(10 m)

11.2 Stores or suitable equivalent to be obtained locally:

Item No. (1)	DMC (2)	NSN/Part No. (3)	Designation (4)	Qty per veh (5)
15	6WPG	2540-99-816-2670	Bag, PVC 36 in. x 24 in. (WPG 8220)	2
16	H2	9330-99-224-5127	Tape, tracing, PVC, white 38 mm wd, 0.2 mm thk	1.5 m
17	6WPG	5970-99-225-1703	Compound, silicone 100 g tube	1
18	6WPG	8030-99-062-9759	PX-24 water displacing fluid	1 litre
19		9150-99-224-8885	Grease XG-286, 3 kg tin	150 g
20		9150-99-943-2033	Grease PX-7, 100 g tube	1
21	H1	6850-99-356-7379	Lec Klene solvent cleaner 300 ml	1
22		6850-99-224-5036	AL-11 windscreen washer fluid	A/R

NOTES

- (1) The item numbers of Para 11 are used as reference throughout this instruction.
- (2) (). Denotes item quantities are supplied as part of the overall Special environment waterproofing kit.
- (3) * Denotes a spare is provided to cater for defective or damaged goods.

GENERAL INSTRUCTIONS

12 The instructions in this publication describe the action to be taken before and after fording to protect the equipment against damage resulting from immersion in sea water.

13 Waterproofing is carried out in stages and each stage is to be completed in the sequence given in this instruction. The tasks within each stage are shown in the most suitable sequence, but this may be varied according to circumstances. Where complete task coverage requires more than one page, the task should be read in its entirety before commencing a page-by-page progression.

14 **CLEANLINESS IS THE FIRST ESSENTIAL OF SUCCESSFUL SEALING.** When applying compounds, ensure that the hands are clean and free from grease and that all surfaces to which sealing compounds are to be applied are scrupulously clean. Mud, oil, grease or water will spoil adhesion.

15 **REMEMBER THAT ALL WATERPROOFING MUST BE 100 % SUCCESSFUL.** One carelessly treated component may cause failure at a critical moment, so take great care with every detail. Whenever waterproofing is being carried out during wet weather, suitable shelter should be arranged over the vehicle.

16 If difficulties are encountered, the Unit MTO should be consulted.

MATERIALS, USES AND APPLICATION

WARNING

HEALTH AND SAFETY. MATERIALS USED IN WATERPROOFING ARE REQUIRED TO MEET OBLIGATIONS INTRODUCED UNDER THE CONTROL OF SUBSTANCES HAZARDOUS TO HEALTH REGULATIONS 1994 (COSHH). SAFETY INFORMATION RELATING TO MATERIALS USED IS CONTAINED IN JSP (F) 395-CATALOGUE OF HAZARDOUS STORES.

17 Lec Klene solvent cleaner: Used for cleaning and degreasing surfaces before applying any of the various waterproofing materials. Lec Klene is a flammable liquid therefore suitable precautions should be taken.

18 Bag, envelope Polyvinyl Chloride (PVC): These bags are manufactured in varying sizes from a waterproof material, which are used to enclose parts of the vehicle as detailed in this instruction and other items as may be desired.

19 Grease: Used for the protection against salt water corrosion on certain parts. The surface should be thoroughly covered with an even, unbroken film of grease. A lumpy coating is wasteful and provides no better protection.

20 Silicone compound: Supplied in 100 g tubes and 12 oz aerosol containers for junction boxes, fuse holders and other electrical components which must remain operative at all times. The components should be covered with a generous, unbroken, even film of silicone compound.

21 Fluid, water displacing: PX-24: Supplied in 1 litre containers. It is used for corrosion prevention and to wash salt water from components as detailed in this AESP.

WATERPROOFING ARRANGEMENTS

22 The operations are to be carried out by Unit personnel unless otherwise stated. **THE WORK IS TO BE PLANNED AND CONTROLLED BY AN OFFICER WHO MUST ARRANGE FOR STAFF, TRAINED IN WATERPROOFING, TO INSPECT ALL TASKS PROGRESSIVELY TO ENSURE THAT THEY ARE COMPLETED SUCCESSFULLY.** A checklist to assist operators will be found at the end of this instruction; it should be photocopied and used to check completion of each task. The operator must initial this list as each task is passed as satisfactory.

CHECKING THE WATERPROOFING KIT

23 Before commencing waterproofing the vehicle, the kit must be checked against the kit list provided.

PREPARATORY SERVICING**CAUTIONS**

(1) **EQUIPMENT DAMAGE.** A thorough examination of build standard waterproofing must be carried out by fully trained/competent personnel. It is essential that any faults found are rectified prior to the commencement of stage 'B' waterproofing.

(2) **VEHICLE PREPARATION.** Waterproofing demands maximum efficiency of vehicle performance. Ensure that your vehicle is 100 % fit for the task.

24 Examine build standard waterproofing with reference to maintenance schedule AESP 2320-D-128- 601, Table 5, Maintenance Interval 3 months or 3000 miles (5000 km). Rectify any faults found.

24.1 Carry out 6000 miles (10000 km) servicing in accordance with AESP 2320-D-128-601, Table 7, to ensure full serviceability for fording. Do not change the engine oil or oil filter unless the vehicle is within 1000 miles (1666 km) of its next scheduled service.

24.2 Fill the vehicle fuel tank to capacity.

Component Location

25 Refer to Fig 1 for the location of engine and ancillary components at the front of the vehicle.

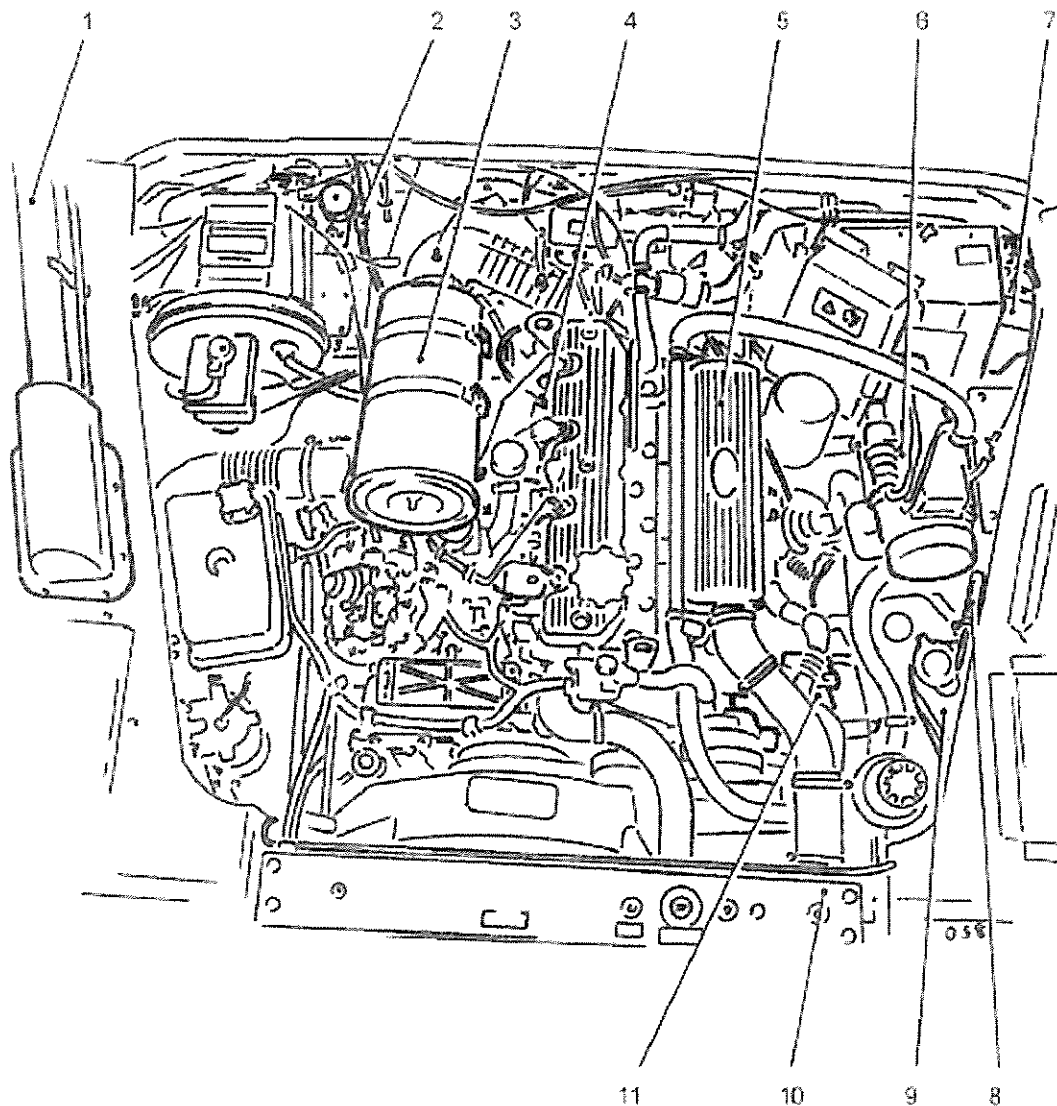

- | | |
|--------------------------------|-------------------------------|
| 1 High level engine air intake | 7 Vehicle heater |
| 2 Fuel tank breather | 8 Alternator disconnect tool |
| 3 Air cleaner | 9 Windscreen washer reservoir |
| 4 Heater plugs | 10 Intercooler |
| 5 Inlet manifold | 11 Alternator |
| 6 Webasto heater | |

Fig 1 Component layout

WATERPROOFING STAGE 'B'**WARNING**

PERSONNEL SAFETY. THE MAXIMUM SPECIFIED FORDING DEPTH FOR THIS EQUIPMENT IS 0.6 METRES AND MUST NOT BE EXCEEDED UNDER ANY CIRCUMSTANCES. THE EQUIPMENT IS SUBJECT TO FLOTATION AT DEPTHS APPROACHING 1 METRE. UNDER CERTAIN CONDITIONS FLOTATION COULD CAUSE THE EQUIPMENT TO TIP OVER OR DRIFT AWAY.

CAUTION

EQUIPMENT DAMAGE. Before commencing waterproofing stage 'B', ensure that a thorough examination of build standard waterproofing has been completed, in accordance with Para 24 of this instruction.

SEQUENCE OF OPERATIONS

26 Carry out this Preparation for Special Environment as follows:

NOTE

Refer to Fig 1, Component layout, for the location of individual engine/ancillary components.

TASK 1 BATTERIES**WARNINGS**

(1) NO SMOKING OR NAKED FLAMES. LEAD ACID BATTERIES PRODUCE POTENTIALLY EXPLOSIVE GASES.

(2) BATTERIES CONTAIN CORROSIVE ACID ELECTROLYTE. WEAR PROTECTIVE GLOVES AND GOGGLES WHEN HANDLING BATTERIES.

27 Remove the passenger seat cushion and the battery compartment cover. Disconnect the negative earth cable from the battery. Temporarily refit the battery compartment cover to prevent accidental short-circuiting during stage 'B' waterproofing.

TASK 2 ENGINE AIR CLEANER**CAUTION**

EQUIPMENT DAMAGE. It is essential that all air cleaner hose connections and the cleaner end cover are secured correctly to provide a watertight seal on the air cleaner casing.

NOTE

This task to be carried out with the assistance of a vehicle mechanic.

28 Check that the air cleaner end cover is correctly secured against the rubber seal on the cleaner body.

28.1 Check that all hoses connected to the air cleaner, intake manifold and intercooler are secure and in good condition.

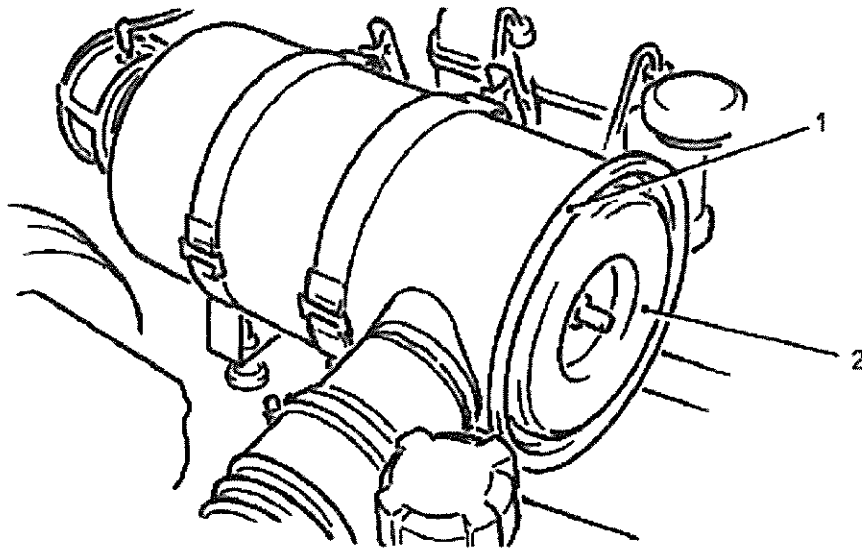

1 Rubber seal 2 End cover

Fig 2 Air cleaner

TASK 3 ALTERNATOR

CAUTION

EQUIPMENT DAMAGE. It is essential the procedure described in this task is followed exactly to isolate the charging system and avoid short circuiting.

NOTES

- (1) This task to be carried out with the assistance of a vehicle mechanic.
- (2) The two alternator multi-plugs are located on a bracket attached to the alternator.

29 Locate the multi-plug disconnect tool attached to the l. h. front wing, above the windscreen washer reservoir. Remove the tool from its clip.

29.1 Using the tool as shown in Fig 3, depress the multi-plug latch, applying light pressure only and disconnect the following:

29.1.1 Red colour coded multi-plug.

29.1.2 Blue colour coded multi-plug.

29.2 Replace the disconnect tool to its original location.

29.3 Connect the free section of the red multi-plug to the fixed section of the blue multi-plug.

29.4 Connect the free section of the blue multi-plug to the fixed section of the red multi-plug.

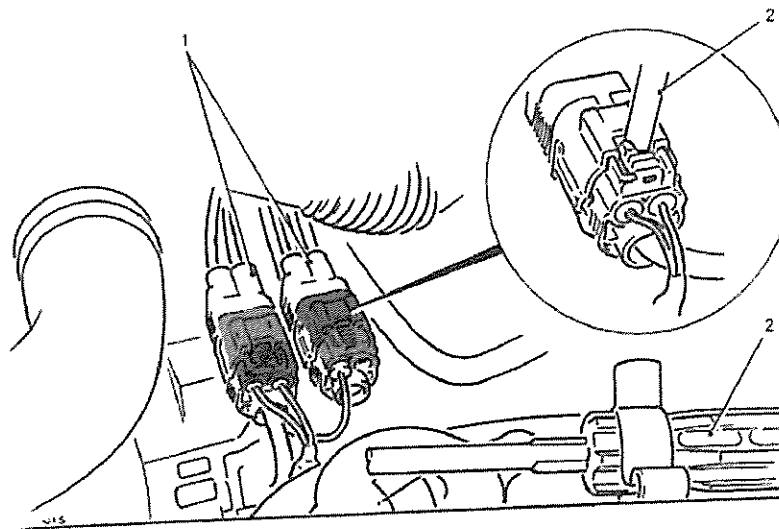

1 Multi-plugs 2 Disconnect tool

Fig 3 Alternator disconnection

29.5 Slacken the wing screw clamp and disconnect the breather hose from the rear of the alternator. Remove the clamp from the hose and place in the kit bag (item 10).

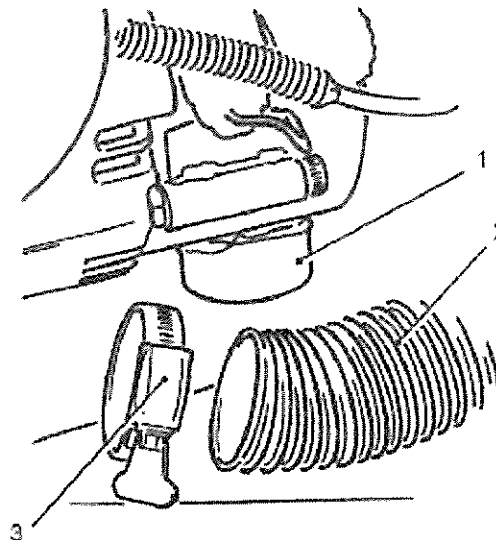

1 End cover 3 Clamp
2 Breather hose

Fig 4 Alternator breather hose

NOTE

The breather hose is located on the underside of the alternator end cover. Access is difficult and care must be taken not to damage any of the intercooler pipes.

29.6 Position the breather hose clear off moving parts and exhaust manifold.

TASK 4 WINDSCREEN WASHER RESERVOIR

WARNING

HEALTH HAZARD. FLUID AL 11 IS HIGHLY INFLAMMABLE. THE PREPARATION OF THE FLUID FOR WINDSCREEN WASHERS IS TO BE CARRIED OUT IN THE OPEN AND AWAY FROM NAKED FLAME. MINIMUM PRECAUTION AFTER USE IS TO WASH ANY AFFECTED SKIN AREAS WITH SOAP AND WATER.

CAUTION

EQUIPMENT DAMAGE. It is essential that the windscreen washer reservoir is filled as detailed in this task to avoid contamination by sea water and subsequent damage to the screen wash equipment.

30 Fill the windscreen washer reservoir to the bottom of the filler neck with a mixture of AL11 (item 22) and water. Refit the reservoir filler cap.

TASK 5 HEATER PLUGS

NOTES

- (1) Do not remove any engine parts when carrying out this task.
- (2) For clarity the air cleaner and breather cyclone are not shown in
- (3) Fig 5.

PX-24

31 Fill spray container (item 11) with PX-24 water displacement fluid (item 18).

31.1 Spray an even coat of PX-24 from container over each of the four heater plug terminal connections for protection against the effects of seawater.

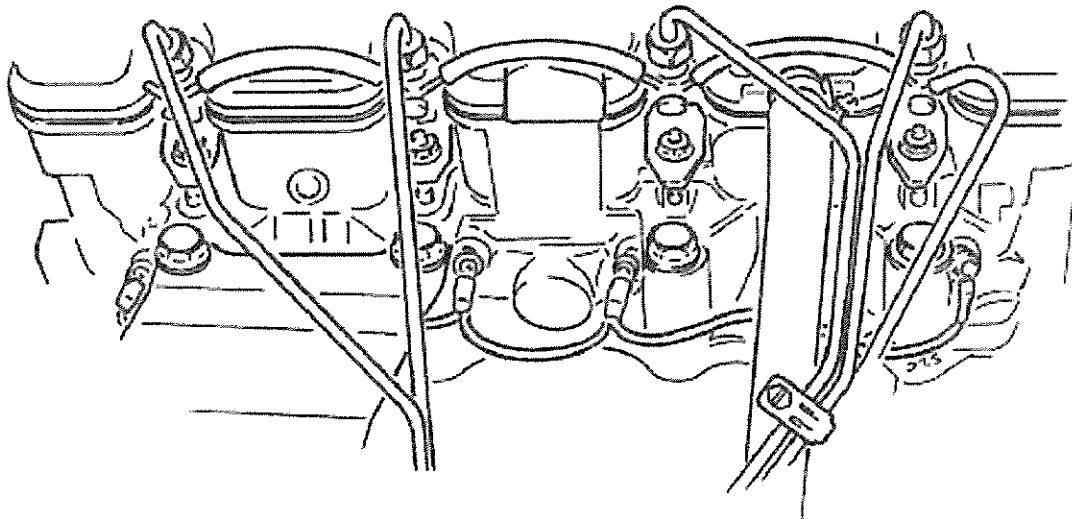

PX-24

Fig 5 Heater plugs

TASK 6 FUEL TANK BREATHER

NOTE

Fuel tank breather connector is located in the engine compartment adjacent to the clutch fluid reservoir.

32 Depress the connector latches as shown in Fig 6 and disconnect the fuel tank breather pipe from the blue colour coded vent pipe.

32.1 Connect the fuel tank breather pipe to the red colour coded pipe of the component breather system.

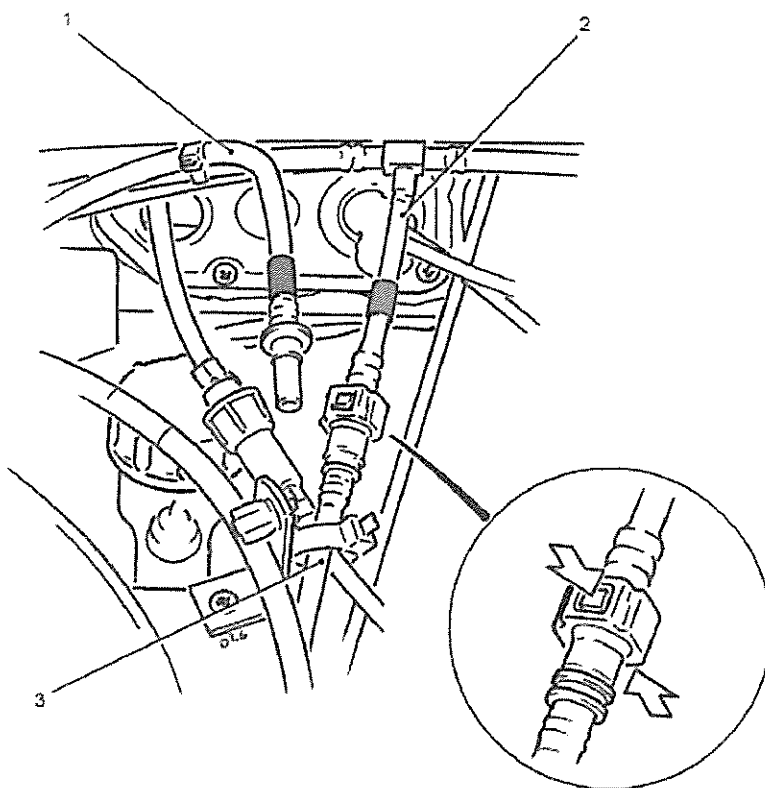

1 Vent pipe

2 Component breather system

3 Fuel tank breather pipe

Fig 6 Fuel tank breather

TASK 7 WEBASTO HEATER

NOTE

This task to be carried out with the assistance of a vehicle mechanic.

33 Slacken the wing screw clamp securing the intake pipe to the heater and remove the intake pipe. Remove the clamp from the pipe, it will be required later in this task.

33.1 Slacken the clamps and disconnect the exhaust pipe from the heater. Remove the exhaust pipe connection sleeve complete with clamps. Do not remove any other exhaust system parts.

33.2 Place air intake pipe and exhaust connection sleeve in a PVC bag (item 15).

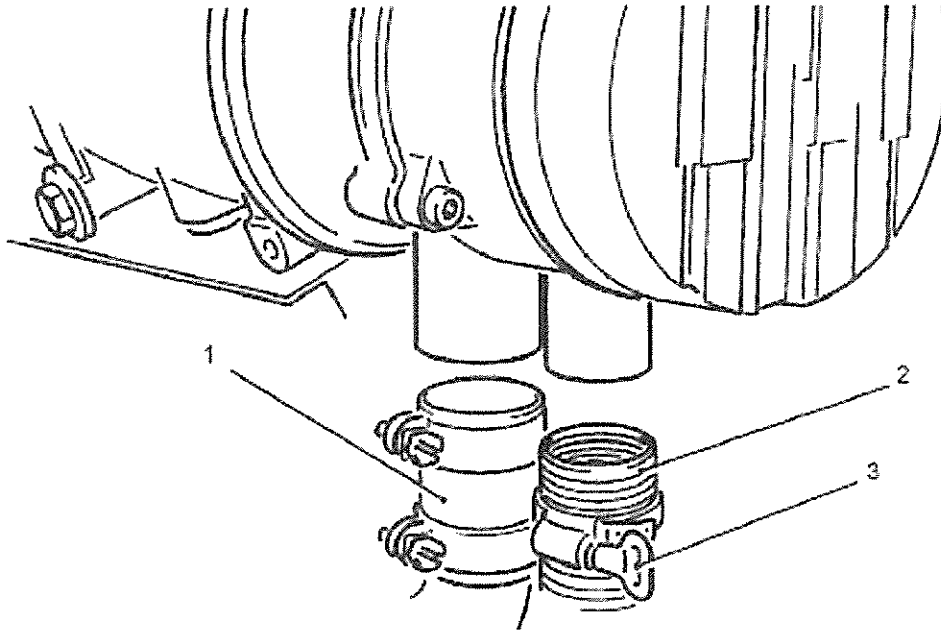

- | | |
|-----------------------------|--------------|
| 1 Exhaust connection sleeve | 3 Wing clamp |
| 2 Intake pipe | |

Fig 7 Webasto heater

33.3 Fit a cap (item 2) over the heater air intake port. Secure cap with the original intake pipe clamp.

33.4 Fit a cap (item 3) over the heater exhaust port. Secure cap with clamp (item 4).

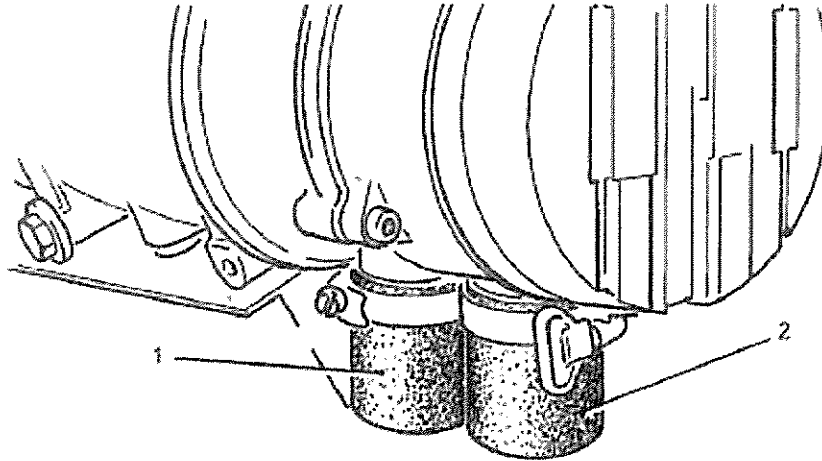

1 Exhaust cap 2 Intake cap

Fig 8 Webasto caps

33.5 Locate the Webasto control switch on the centre console in the driver's cab. Ensure the switch is in the 'OFF' position. Prise the control knob from the switch and place in the kit bag (item 10). This is done to prevent accidental operation of the heater during fording operations.

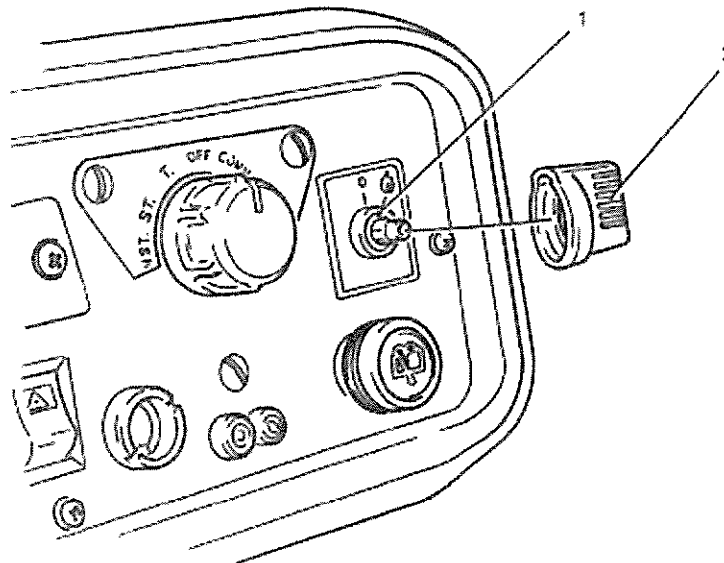

1 Switch 2 Control knob

Fig 9 Webasto switch

TASK 8 HEATER

NOTE

The two heater multi-plugs are attached to the heater unit at the rear of the engine compartment.

34 Depress the latch as shown in Fig 10 and disconnect the grey and orange multi-plugs.

34.1 Connect the grey multi-plug to the orange multi-plug blank.

34.2 Connect the orange multi-plug to the grey multi-plug.

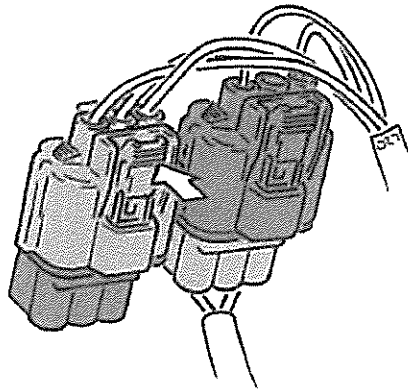
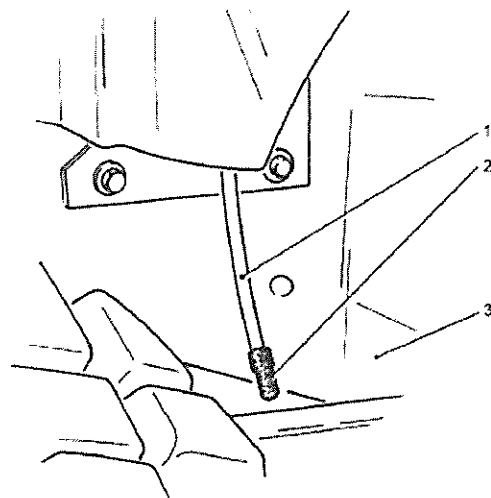

Fig 10 Heater multi-plugs

NOTE

The motor drain tube is situated at the rear of the left hand front wheel arch adjacent to the chassis side member. Access is gained beneath the left hand front wing.

34.3 Fit a cap (item 5) over the end of the motor drain tube.



- 1 Drain tube
- 2 Cap
- 3 Chassis side member

Fig 11 Motor drain

TASK 9 INTER-VEHICLE START SOCKET

35 Remove socket cap. Apply an even coat of silicone compound (item 17) over socket threads and socket rubber seal using a fitch brush (item 12). Refit and tighten cap.

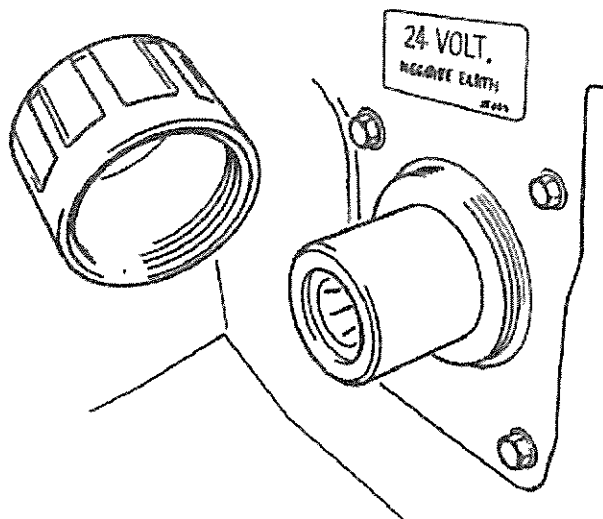
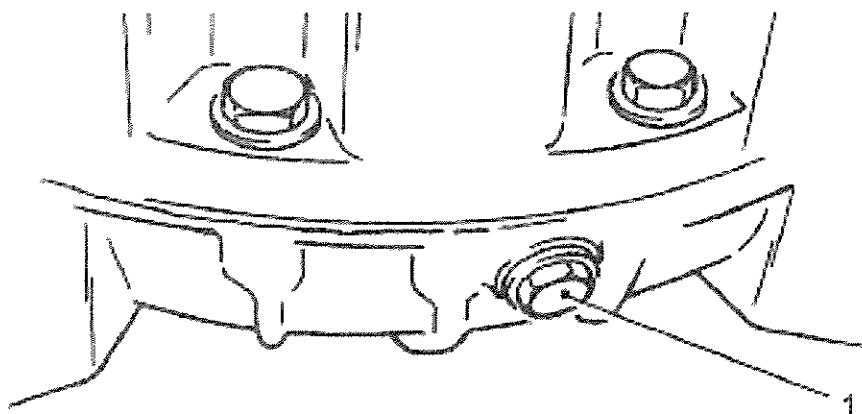

Fig 12 Inter-vehicle start socket

TASK 10 FLYWHEEL HOUSING

36 Fit and tighten drain plug (item 6) to flywheel housing.



1 Drain plug

Silicone compound

Fig 13 Flywheel housing

TASK 11 EBERSPACHER REAR BODY HEATER

NOTES

- (1) This task to be carried out with the assistance of a vehicle mechanic.
 - (2) The Eberspacher intake and exhaust pipes are located under the right hand front corner of the rear body behind the driver's cab.
- 37 Release the clamps and remove the air intake pipe from the underside of the heater.
- 37.1 Slacken the clamp and disconnect the exhaust pipe from the underside of the heater. Remove the clamp from the pipe.
- 37.2 Place the exhaust clamp and the air intake pipe complete with securing clamps and screws in a PVC bag (item 15). Stow and secure the bag in a safe place on board vehicle.
- 37.3 Apply a thin coat of silicone compound (item 17) to the inside surface of a cap (item 7). Fit the cap over the heater intake port. Secure cap with clamp (item 8).
- 37.4 Apply a thin coat of silicone compound (item 17) to the inside surface of a cap (item 7). Fit the cap over the heater exhaust port. Secure cap with clamp (item 8).
- 37.5 Secure the exhaust pipe to the exhaust port with cable tie (item 9).

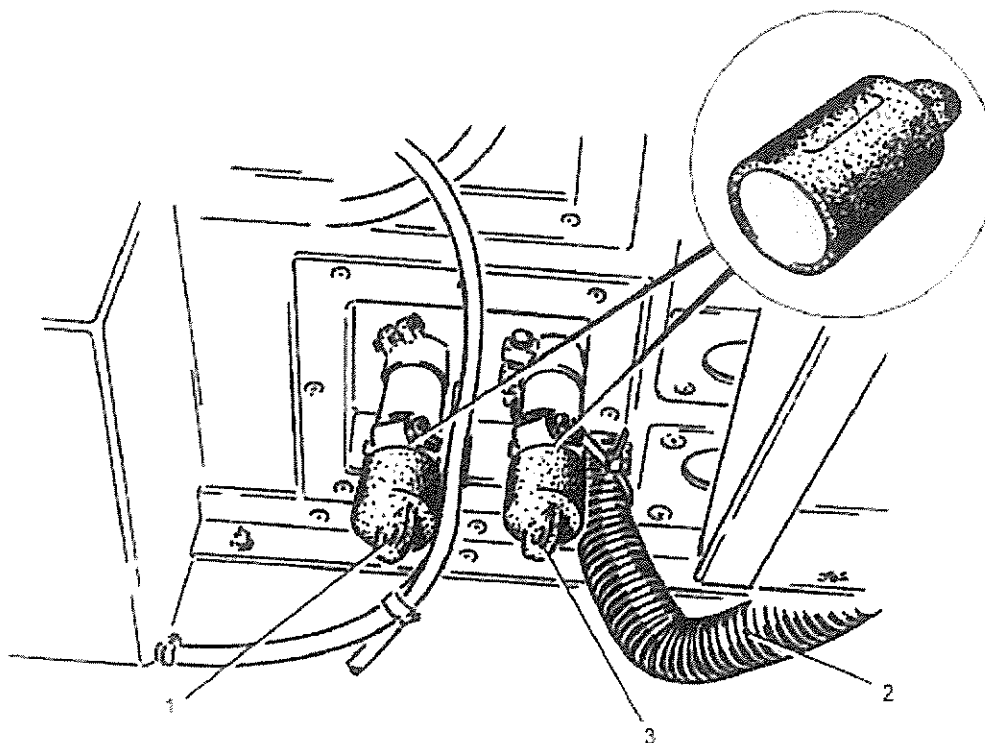

- | | |
|----------------|---------------|
| 1 Intake cap | 3 Exhaust cap |
| 2 Exhaust pipe | |

Silicone compound

Fig 14 Eberspacher heater

37.6 Locate the Eberspacher control switch on the power distribution panel inside the ambulance body. Ensure the switch is in the 'OFF' position. Prise the control knob from the switch and place in the kit bag (item 10). This is done to prevent accidental operation of the heater during fording operations.

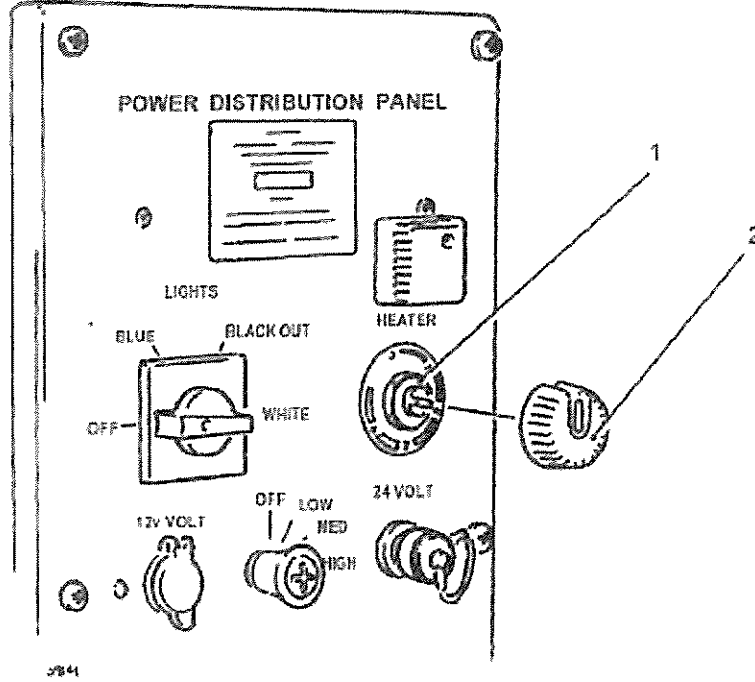

1 Switch 2 Control knob

Fig 15 Eberspacher switch

37.7 Close the external fresh air ventilator grille located on the right hand side of the vehicle behind the driver's door.

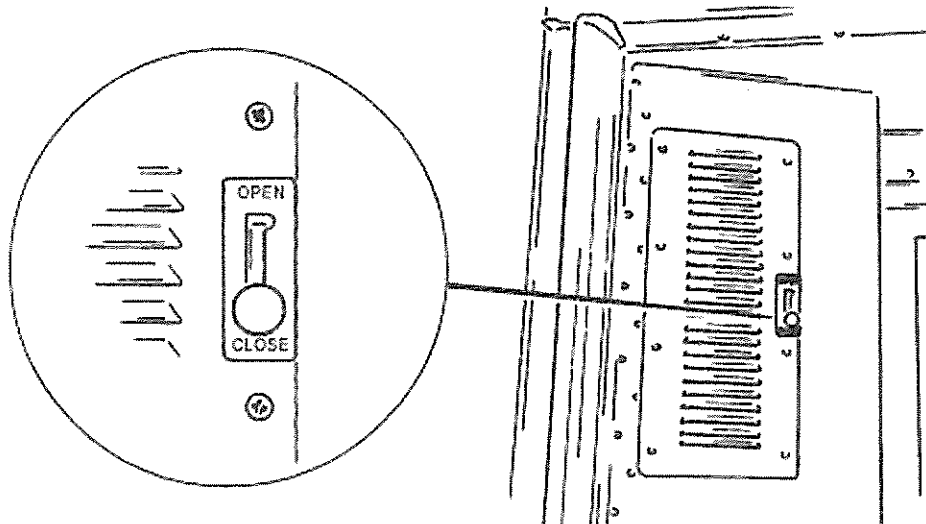

Fig 16 Ventilator grille

TASK 12 BATTERIES (2)

WARNINGS

(1) **NO SMOKING OR NAKED FLAMES. LEAD ACID BATTERIES PRODUCE POTENTIALLY EXPLOSIVE GASES.**

(2) **BATTERIES CONTAIN CORROSIVE ACID ELECTROLYTE. WEAR PROTECTIVE GLOVES AND GOGGLES WHEN HANDLING BATTERIES.**

38 Reconnect the negative earth cable to the battery. Apply a liberal coat of PX-7 grease (item 20) to all battery terminals, ensuring they are completely covered. Refit the cover over the positive terminal.

38.1 Refit battery compartment cover and front seat cushion.

TASK 13 PRESERVATION

39 Apply an even coat of grease XG-286 (item 19) using brush (item 13) for preservation against salt water immersion to the following:

39.1 Jerrycan stowage door hinges.

39.2 Wheel nuts.

TASK 14 TOWROPE

40 Connect a suitable towrope to the front tow pin. Tie one end of rope (item 14) to the free end of towrope. Create a suitable large knot at the other end so that it may be used as a throwing line.

40.1 Position free end of towrope up over bonnet and through the front window of the passenger door. Secure the towrope inside the vehicle. Ensure the rope does not slip from the bonnet and foul the road wheels during transit.

TASK 15 STAGE 'B' KIT AND ITEMS OF EQUIPMENT

41 Refill the spray container (item 11) with PX-24 (item 18), ensure the top is tightly secured and place in the kit bag (item 10). It is required for de-waterproofing stages 'C' and 'D'.

41.1 Place remaining items of the stage 'B' kit and items removed during stage 'B' waterproofing in the kit bag (item 10). Stow and secure the bag in a safe place on board vehicle.

41.2 Place the tool roll, jack and other loose items in the driver's under seat stowage compartment in a PVC bag (item 15). Fold the neck of the bag and restow in the stowage compartment ensuring the bag opening is uppermost.

TASK 16 ESCAPE PROCEDURE

WARNING

PERSONNEL SAFETY. A REMOVABLE WINDOW IS LOCATED ON EITHER SIDE OF THE AMBULANCE BODY TO PROVIDE A MEANS OF ESCAPE FROM THE VEHICLE IN AN EMERGENCY. THE INSTRUCTIONS IN THIS TASK MUST BE FULLY UNDERSTOOD AND COMPLIED WITH DURING FORDING OPERATIONS:

42 The removable windows are for use if the vehicle doors cannot be opened.

42.1 Roll up and secure the blackout blind of the removable windows located on either side of the rear body.

42.2 Ensure that the upper stretcher support frames are in the casualty carrying position to provide clear access to the windows.

42.3 Cut a 500 mm length of tape (item 16). Pass the tape through the ring pull of the left hand removable window and secure with a double knot. This is done to provide easy identification of the ring pull in the event of an emergency.

42.4 Repeat Para 42.3 for the right hand window.

42.5 Refer to AESP 2320-D-128-201 Chap 3-3 for correct operation of the removable windows.

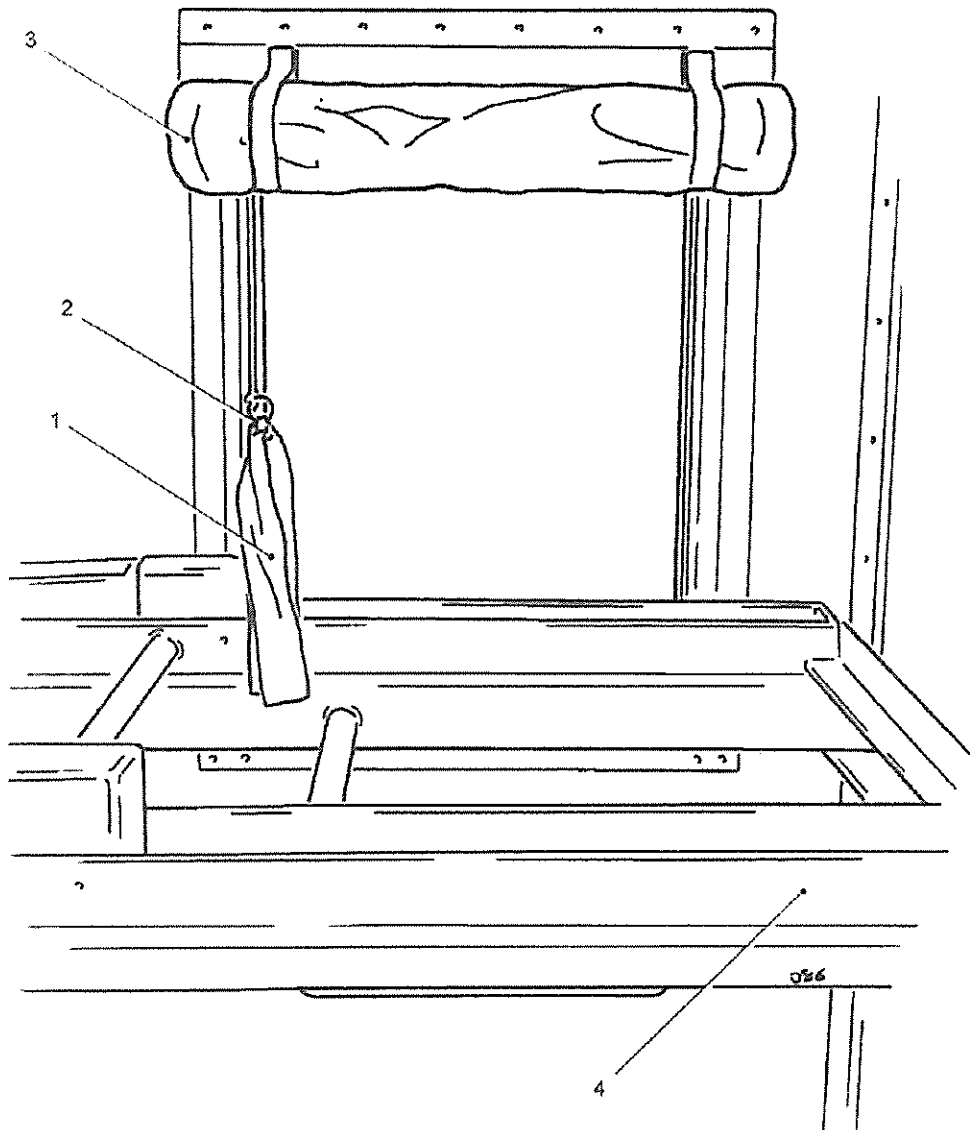

- | | |
|-------------|---------------------------|
| 1 Tape | 3 Blackout blind |
| 2 Ring pull | 4 Stretcher support frame |

Fig 17 Rear window

TASK 17 WATERPROOFING THE AESP

43 Read and memorize Task 18: "Driving instructions for deep fording".

43.1 Stow and secure this AESP in a safe place on board vehicle. It will be required for de-waterproofing stages 'C' and 'D'.

TASK 18 DRIVING INSTRUCTIONS FOR DEEP FORDING

WARNING

PERSONNEL SAFETY. THE MAXIMUM SPECIFIED FORDING DEPTH FOR THIS EQUIPMENT IS 0.6 METRES AND MUST NOT BE EXCEEDED UNDER ANY CIRCUMSTANCES. THE EQUIPMENT IS SUBJECT TO FLOTATION AT DEPTHS APPROACHING 1 METRE. UNDER CERTAIN CONDITIONS FLOTATION COULD CAUSE THE EQUIPMENT TO TIP OVER OR DRIFT AWAY.

CAUTIONS

(1) EQUIPMENT DAMAGE. If the vehicle stalls with the engine underwater no attempt must be made to restart the engine before Drowned Vehicle Procedure is completed.

(2) EQUIPMENT DAMAGE. It is essential to keep the vehicle moving through the water as 'loss of momentum' could cause failure. Do not change gear whilst in the water.

44 Engage first gear, low ratio with differential lock.

44.1 Enter the water as slowly as possible, depress the accelerator and ensure the maximum speed does not exceed 8 mph (13 kph). Ensure the maximum water depth of 600 mm is not exceeded.

44.2 In the event of a vehicle failure, the driver must engage neutral gears before any recovery is attempted.

44.3 If the failure is due to loss of traction. The driver should keep the engine running during beach recovery, providing the engine air intake is clear of the water.

44.4 If the failure is due to a vehicle stall. No attempt must be made to restart the engine before Drowned Vehicle Procedure (DVP) is completed after beach recovery.

DE-WATERPROOFING STAGE 'C'**CAUTIONS**

- (1) **TIME LIMITATION.** The following Tasks must be conducted within 15 minutes of leaving the water.
- (2) **DEFECT REPORTING.** All defects including occurrences of water ingress found during stage 'C' de-waterproofing, must be reported to a senior member of Unit ES staff as soon as operationally possible, for appropriate Equipment Failure Report (EFR) action.

TASK 19 ENGINE OIL LEVEL**WARNINGS**

- (1) **PERSONNEL SAFETY. EXTREME CARE MUST BE TAKEN WHEN DRAINING ENGINE OIL. HOT ENGINE OIL CAN CAUSE SEVERE PERSONAL INJURY.**
- (2) **HEALTH HAZARD. PROLONGED AND REPEATED CONTACT WITH USED ENGINE OILS MAY CAUSE SERIOUS SKIN DISORDERS, INCLUDING DERMATITIS AND CANCER.**

CAUTION

OIL LEVEL. The oil level must never be above the 'FULL' mark as engine damage may be caused.

- 45 Check engine oil level, if contaminated drain and refill with correct grade oil.

TASK 20 ALTERNATOR RECONNECTION

- 46 Stop engine. Remove the passenger seat cushion and the battery compartment cover. Disconnect the negative earth cable from the battery.

- 46.1 Locate the multi-plug disconnect tool attached to the Left Hand front wing above the windscreen washer reservoir.
- 46.2 Using the tool depress the multi-plug latch, applying light pressure only and disconnect the two multi-plugs.
- 46.3 Replace the disconnect tool to its original location.
- 46.4 Connect the grey multi-plugs together.
- 46.5 Connect the red multi-plugs together.
- 46.6 Reconnect battery negative cable. Refit battery cover and seat cushion.
- 46.7 Start engine and check that the alternator is functioning correctly.

TASK 21 FUEL TANK BREATHER

- 47 Depress connector latches and disconnect fuel tank breather pipe from the red colour coded pipe.
- 47.1 Connect fuel tank breather pipe to the blue colour coded vent pipe.

TASK 22 HEATER MOTOR

48 Remove bung from motor drain tube, stow bung in the kit bag (item 10).

48.1 Delatch multi-plugs and connect the grey multi-plugs together.

48.2 Connect the orange multi-plugs together.

TASK 23 FLYWHEEL HOUSING

49 Remove flywheel housing drain plug and check for contamination. Stow plug in the kit bag (item 10).

TASK 24 HEATER PLUGS

50 Spray PX-24 (item 18) from container (item 11) over each glow plug terminal connection to flush away any sand and salt. Stow container in the kit bag (item 10).

TASK 25 TOWROPE

51 Remove towrope from vehicle. Stow towrope in a safe place on board vehicle.

TASK 26 REMOVABLE REAR WINDOWS

52 Remove and discard the tape from the ring pulls of the two removable windows located on either side of the rear body.

TASK 27 TEMPORARY HALT PROCEDURE

53 If a temporary halt procedure is necessary, the following precautions should be actioned:

53.1 Disconnect negative cable from battery.

53.2 Chock road wheels.

53.3 Leave the handbrake in the 'OFF' position.

DE-WATERPROOFING STAGE 'D'**CAUTIONS**

- (1) **MILEAGE LIMITATION AFTER DISEMBARKATION.** Tasks 28, 29, and 30 must be carried out after 25 miles (40 km) or 12 hours (whichever occurs first), from point of disembarkation if operationally possible. The remaining tasks should be carried out as soon as conditions permit but within 250 miles (400 km) or 3 days (whichever occurs first), of landing.
- (2) **WASH DOWN.** The alternators must be washed down with fresh water after fording; within three to four hours.
- (3) **DEFECT REPORTING.** All defects including occurrences of water ingress found during stage 'D' de-waterproofing, must be reported to a senior member of unit ES staff as soon as operationally possible, for appropriate Equipment Failure Report (EFR) action.

TASK 28 OIL CHANGE**WARNINGS**

- (1) **PERSONNEL SAFETY. EXTREME CARE MUST BE TAKEN WHEN DRAINING ENGINE OIL. HOT ENGINE OIL CAN CAUSE SEVERE PERSONAL INJURY.**
- (2) **HEALTH HAZARD. PROLONGED AND REPEATED CONTACT WITH USED ENGINE OILS MAY CAUSE SERIOUS SKIN DISORDERS, INCLUDING DERMATITIS AND CANCER.**

54 Check all oil levels. If water is present in any assembly:

- 54.1 Drain oil.
- 54.2 Refill with correct grade lubricant.

TASK 29 CLUTCH AND BRAKES

55 To prevent seizure of clutch and brakes when parked, every opportunity should be taken to:

- 55.1 Prop out clutch pedal with a suitable prop.
- 55.2 Chock road wheels and leave handbrake 'OFF'.

TASK 30 ALTERNATOR BREATHER**WARNING**

HEAT INJURY HAZARD. EXHAUST COMPONENTS WILL BECOME VERY HOT WHEN THE ENGINE IS RUNNING. IN ORDER TO PREVENT THE POSSIBILITY OF SEVERE PERSONAL INJURY, ADEQUATE TIME MUST BE ALLOWED FOR THE SYSTEM TO COOL BEFORE ANY WORK IS UNDERTAKEN IN THE VICINITY OF THE EXHAUST MANIFOLD.

NOTES

- (1) This task to be carried out with the assistance of a vehicle mechanic.
 - (2) The breather is located on the underside of the alternator end cover. Access is difficult and care must be taken not to damage any of the intercooler pipes.
- 56 Refit the alternator breather hose and secure with the original wing screw clamp.

TASK 31 WASH DOWN

CAUTIONS

(1) **EQUIPMENT DAMAGE.** Water entering the engine air intake system will cause major failure when the engine is restarted. Do not direct the wash down hose at the high level air intake or allow water to enter the intake system. Avoid prolonged hosing of electrical equipment.

(2) **EQUIPMENT DAMAGE.** Do not pressure wash down the insides of the vehicle. Unprotected Battlefield Ambulance and vehicle equipment will be seriously damaged by pressure washing.

57 It is important that the correct wash down procedures are observed.

57.1 The following guidelines must be adhered to when washing down the vehicle to avoid damage to the wax protective coating and unprotected internal equipment:

57.1.1 Cold water pressure washing is preferred. In any event, water temperature should not exceed 60 degrees C.

57.1.2 Pressure of water should not exceed 1200 PSI.

57.1.3 Ensure a distance of approximately 30 cm between the nozzle lance and the surface being washed.

57.1.4 No detergent is to be used.

57.1.5 Do not hose down the insides of the vehicle.

57.1.6 Ensure all windows and doors are closed.

57.1.7 Ensure all external ventilators are closed.

57.2 Remove the passenger seat cushion and the battery compartment cover. Disconnect the negative cable from the battery.

57.3 Wash down the vehicle thoroughly with freshwater. Remove all traces of sand and salt deposits. Ensure the following areas are included:

57.3.1 All exterior surfaces and underbody areas.

57.3.2 Engine and all underbonnet areas.

57.3.3 Jerrycan stowage compartments.

57.3.4 Top of fuel tank and tank filler neck compartment.

57.4 Reconnect the negative cable to the battery. Refit battery compartment cover and passenger seat cushion.

TASK 32 WEBASTO HEATER

NOTE

This task to be carried out with the assistance of a vehicle mechanic.

58 Flush the exhaust system through with freshwater. Take care that no other vehicle systems are contaminated with water.

- 58.1 Remove the caps from the intake and exhaust ports. Stow the caps and the exhaust cap clamp in the kit bag (item 10).
- 58.2 Install the connection sleeve and refit the exhaust to the heater. Ensure clearance between the Webasto exhaust and the engine turbocharger.
- 58.3 Refit the intake pipe to the heater and secure with its original clamp. Ensure the pipe is fitted through its support clip and the open end is facing downward.
- 58.4 Spray an even coat of PX-24 (item 18) from container (item 11) over the heater to wash off any sand or salt deposits.
- 58.5 Refit the heater switch knob.
- 58.6 Operate heater for 15 minutes for drying out purposes and to check that it is functioning correctly.

TASK 33 EBERSPACHER REAR BODY HEATER

NOTE

This task to be carried out with the assistance of a vehicle mechanic.

- 59 Remove and discard the cable tie securing the exhaust pipe to the exhaust port. Hose through the exhaust pipe with freshwater.
- 59.1 Remove the caps from the intake and exhaust ports. Stow the caps and clamps in the kit bag (item 10).
- 59.2 Refit the air intake pipe to the heater and secure with original clamps.
- 59.3 Refit the exhaust pipe to the heater and secure with original clamp.
- 59.4 Refit the heater switch knob.
- 59.5 Open the external fresh air ventilator grille located on the right hand side of the vehicle behind the driver's cab.
- 59.6 Operate heater for 15 minutes for drying out purposes and to check that it is functioning correctly.

TASK 34 HUBS AND BRAKES

WARNINGS

- (1) **HEALTH HAZARD. BEFORE THE COMMENCEMENT OF ANY PAINTING, REFER TO AESP 0200-A-221-013, 'PAINTING OF SERVICE EQUIPMENT' AND THE RELEVANT COSHH REGULATIONS FOR THE MATERIAL.**
- (2) **SAFETY. DO NOT ALLOW ANY PAINT TO CONTAMINATE THE BRAKE LININGS OR THE FRICTION SURFACES OF THE BRAKE DRUM.**

NOTE

This task to be carried out with the assistance of a vehicle mechanic.

- 60 Strip and service all wheel hubs ensuring that the hub oil seals are renewed (refer to AESP 2320-D-128-522 Chap 5 and 6). Wash off stub axles with PX-24 (item 18) using the spray container (item 11) to remove all traces of sand and salt deposits.

60.1 Ensure serviceability of brake pads and calipers before reassembly (refer to AESP 2320-D-128-522 Chap 10).

60.2 Strip and service the transmission brake (refer to AESP 2320-D-128-522 Chap 10). Wash off the oil seal area of the transfer box drive flange with PX-24 (item 18) using the spray container (item 11). Ensure all traces of sand and salt deposits are removed.

60.3 Prior to reassembly, paint the following items with red oxide NSN H1 8010-99-910-6645 for protection. Do not contaminate brake linings or friction surface areas of the brake drum with paint.

60.3.1 Brake shoes.

60.3.2 Brake back plate.

60.3.3 Brake drum.

60.3.4 Lubricate the handbrake ratchet pawl linkage with OMD 80X oil.

TASK 35 STOWAGE COMPARTMENTS

WARNING

HEALTH HAZARD. BEFORE THE COMMENCEMENT OF ANY PAINTING, REFER TO AESP 0200-A-221-013, 'PAINTING OF SERVICE EQUIPMENT' AND THE RELEVANT COSHH REGULATIONS FOR THE MATERIAL.

61 Remove all traces of sand and salt deposits from the jerry can stowage compartment.

61.1 Remove the PVC bag containing the tools and equipment from the stowage compartment under the driver's seat.

61.2 Remove all traces of sand and salt deposits from the stowage compartment.

61.3 Restore any damaged paint finish to the jerry can and under seat stowage compartments.

61.4 Remove tools and equipment from the PVC bag and restow to the correct locations in the under seat stowage compartment.

TASK 36 BATTERY COMPARTMENT

WARNINGS

(1) **NO SMOKING OR NAKED FLAMES. LEAD ACID BATTERIES PRODUCE POTENTIALLY EXPLOSIVE GASES.**

(2) **BATTERIES CONTAIN CORROSIVE ACID ELECTROLYTE. WEAR PROTECTIVE GLOVES AND GOGGLES WHEN HANDLING BATTERIES.**

(3) **HEALTH HAZARD. BEFORE THE COMMENCEMENT OF ANY PAINTING, REFER TO AESP 0200-A-221-013, 'PAINTING OF SERVICE EQUIPMENT' AND THE RELEVANT COSHH REGULATIONS FOR THE MATERIAL.**

NOTE

This task to be carried out with the assistance of a vehicle mechanic.

62 Remove passenger seat cushion and the battery compartment cover. Disconnect and remove the batteries. Undo the fixings and remove the battery trays.

- 62.1 Remove all traces of sand and salt deposits from the battery compartment and the battery trays. Allow the compartment to completely dry out.
- 62.2 Restore any damaged paint finish to the battery compartment and the battery trays.
- 62.3 Refit the battery trays.
- 62.4 Clean the battery casings. Refit and reconnect the batteries. Apply a coat of PX-7 grease (item 20) to the terminals.
- 62.5 Refit battery compartment cover and the seat cushion.
- 62.6 From under the vehicle, apply a coat of 'Dinol' wax to the battery tray fixings to preserve the underbody wax protection (refer to AESP 2320-D-128-522 Chap 16).

TASK 37 FLOOR COVERINGS

WARNING

HEALTH HAZARD. BEFORE THE COMMENCEMENT OF ANY PAINTING, REFER TO AESP 0200-A-221-013, 'PAINTING OF SERVICE EQUIPMENT' AND THE RELEVANT COSHH REGULATIONS FOR THE MATERIAL.

NOTE

This task is only required if water has entered the driver's cab foot wells during fording.

- 63 Remove the cab foot well mats.

- 63.1 Remove all traces of sand and salt deposits from the cab foot wells. Allow the foot wells to completely dry out.
- 63.2 Restore any damaged paint finish to the foot wells.
- 63.3 Wash off the mats with freshwater and allow to dry.
- 63.4 Refit the mats.

TASK 38 COMPONENT BREATHER SYSTEM DRAIN

NOTES

- (1) This task to be carried out with the assistance of a vehicle mechanic.
- (2) The drain tube is located at the rear of the right hand front wheel arch, above the chassis outrigger. Access is gained beneath the right hand front wing.

- 64 Release the hose clamp, remove the plug and drain any contamination. Refit the plug and tighten the clamp.

- 64.1 If contamination is more than could be expected from condensation, the cause must be investigated and rectified.

TASK 39 FRONT AND REAR LIGHTS

- 65 Examine front and rear lights for contamination. If contamination is present in any light:

- 65.1 Remove and drain light.
- 65.2 Wash out light in freshwater and dry off thoroughly.

65.3 Refit light (refer to AESP 2320-D-128-201 Chap 4).

TASK 40 PROPELLER SHAFTS

66 Grease gun lubricate all propeller shaft joints to expel any sea water (refer to AESP 2320-D-128-601, Table 7).

TASK 41 LUBRICATION AND MAINTENANCE

NOTE

This task to be carried out with the assistance of a vehicle mechanic.

67 Complete the 6000 miles (10000 km) maintenance schedule (refer to AESP 2320-D-128-601, Table 7).

TASK 42 ENGINE CONTROLS

NOTE

This task to be carried out with the assistance of a vehicle mechanic.

68 Lubricate the engine controls with OMD 80X oil and ensure correct operation.

TASK 43 FUTURE WATERPROOFING REQUIREMENTS

69 Examine the content and condition of the stage 'B' waterproofing kit. Re-demand replacement items, detailed in the kit list at Para 11.1 as necessary for future waterproofing use.

TABLE 2 WATERPROOFING TASK CHECK LIST TRUCK UTILITY MEDIUM AMBULANCE (HS)

VEHICLE NO.

Page No. (1)	Para No. (2)	Item (3)	Initialed Completed (4)
10	-	WATERPROOFING STAGE 'B'	
10	26	Sequence of operations	
10	27	Task 1 Batteries	
10	28	Task 2 Engine air cleaner	
11	29	Task 3 Alternator	
13	30	Task 4 Windscreen washer reservoir	
13	31	Task 5 Heater plugs	
14	32	Task 6 Fuel tank breather	
15	33	Task 7 Webasto heater	
17	34	Task 8 Heater	
18	35	Task 9 Inter-vehicle start socket	
18	36	Task 10 Flywheel housing	
19	37	Task 11 Eberspacher rear body heater	
21	38	Task 12 Batteries (2)	
21	39	Task 13 Preservation	
21	40	Task 14 Towrope	
21	41	Task 15 Stage 'B' kit and items of equipment	
21	42	Task 16 Escape procedure	
23	43	Task 17 Waterproofing the AESP	
23	44	Task 18 Driving instructions for deep fording	
24	-	DE-WATERPROOFING STAGE 'C'	
24	45	Task 19 Engine oil level	
24	46	Task 20 Alternator reconnection	
24	47	Task 21 Fuel tank breather	
25	48	Task 22 Heater motor	
25	49	Task 23 Flywheel housing	
25	50	Task 24 Heater plugs	
25	51	Task 25 Towrope	
25	52	Task 26 Removable rear windows	
25	53	Task 27 Temporary halt procedure	
26	-	DE-WATERPROOFING STAGE 'D'	
26	54	Task 28 Oil change	
26	55	Task 29 Clutch and brakes	
26	56	Task 30 Alternator breather	
27	57	Task 31 Wash down	

(continued)

TABLE 2 WATERPROOFING TASK CHECK LIST TRUCK UTILITY MEDIUM AMBULANCE (HS)
(continued)

VEHICLE NO.

Page No. (1)	Para No. (2)	Item (3)	Initialed Completed (4)
26	-	DE-WATERPROOFING STAGE 'D' (continued)	
27	58	Task 32 Webasto heater	
28	59	Task 33 Eberspacher rear body heater	
28	60	Task 34 Hubs and brakes	
29	61	Task 35 Stowage compartments	
29	62	Task 36 Battery compartment	
30	63	Task 37 Floor coverings	
30	64	Task 38 Component breather system drain	
30	65	Task 39 Front and rear lights	
31	66	Task 40 Propeller shafts	
31	67	Task 41 Lubrication and maintenance	
31	68	Task 42 Engine controls	
31	69	Task 43 Future waterproofing requirements	

PAGE LEFT INTENTIONALLY BLANK

TRUCK UTILITY LIGHT (TUL) HS,
TRUCK UTILITY MEDIUM (TUM) HS

PREPARATION FOR SPECIAL ENVIRONMENT INSTRUCTION NO. 4
IMPROVED AIR FILTRATION SYSTEM FOR DESERT ENVIRONMENT

CONTENTS

Sponsor: OSVP PT
Project number:
File ref: DGES(L) CSE/15/10/1
Publication agency: OSVP PT, DE&S Abbey Wood

AMENDMENT RECORD

Amdt No.	Incorporated By (Signature)	Date	Amdt No.	Incorporated By (Signature)	Date
1			4		
2			5		
3			6		

SUBJECT: Installation of improved air filtration systems for operation in desert environment

CONTENTS

Para

- 1 Introduction
- 4 Related and associated publications
- 5 Applicability
- 6 Stores required
- 8 Task 1 engine air cleaner (CAUTION)
- 16 Task 2 raised air intake
- 41 Task 3 raised air intake when vehicle protection kit (VPK) is fitted
- 46 Task 4 air intake blanking plate
- Maintenance instructions (CAUTION)
- 52 General
- 54 Two-stage air cleaner maintenance instructions

Table

	Page
1 Man hour content	4

Fig

	Page
1 Air cleaner mounting bracket fitted to TUM/TUL HS	6
2 Interface bracket dimensions	6
3 Revised air cleaner mounted at an angle to engine	7
4 Trimming of excess material from inner duct	8
5 Fitting of spire clips.....	8
6 Attach outer duct by using single screw first.....	8
7 Attach outer duct with further 3 screws	9

(continued)

CONTENTS (continued)

Fig		Page
8	Mounting bracket drilling dimensions	9
9	Bracket position	10
10	Attaching upright air intake pipe	10
11	Installation of centrifuge insert	10
12	Pre-cleaner alignment	11
13	Attach pre-cleaner with pop rivets	11
14	Mounting bracket drilling dimensions - when fitted with VPK.....	11
15	Mounting of adaptor bracket	12
16	Secure blanking plate.....	12
17	Refit air intake grille.....	13

INTRODUCTION

1 Owing to the ingestion of sand whilst operating in a desert environment, a large number of turbocharger failures, and in some cases, engine failures have occurred. To address this, a raised air intake and improved air cleaner assembly are to be fitted. This instruction details the method of fitting the improved air filtration systems that are to be incorporated when operating in desert conditions.

2 Fitting of a snorkel with high-level intake lifts the air intake to approximately 2 m above ground level thus reducing the levels of sand previously introduced through the air intakes situated behind the front wheel arches. The revised Donaldson air cleaner assembly features 2-stage filtration that can achieve over 99% efficiency. Design of the replacement air cleaner assembly also reduces the chance of incorrectly assembled parts allowing unfiltered air into the engine system.

3 This Preparation for Special Environment can be carried out on both left and right hand drive variants and those vehicles with Vehicle Protection Kit (VPK) modification fitted, with only minor modifications to the vehicle and using in-service tools and equipment.

NOTE

Once fitted, the revised Air Filter and Hi-level Air Intake are to remain as part of the vehicle.

Related and associated publications

- 4 Refer to Army Equipment Support Publication (AESP):
- | | | |
|-----|----------------|-----------------------------|
| 4.1 | 2320-D-128-201 | Operating Information |
| 4.2 | 2320-D-128-522 | Maintenance Instructions |
| 4.3 | 2320-D-128-523 | Repair Instructions |
| 4.4 | 2320-D-128-601 | Maintenance Schedule |
| 4.5 | 2320-D-128-711 | Illustrated Parts Catalogue |

APPLICABILITY

5 Truck Utility Light (TUL) (HS) and Truck Utility Medium (TUM) (HS) all variants. Except Winterised/Waterproofed variants.

STORES REQUIRED

6 Items for desertisation of equipment are MOD controlled stores.

TABLE 1 MAN HOUR CONTENT

Serial (1)	Detail (2)	Approximate time in man-hours (3)
1	Perusal of this AESP and checking against contents list	0.5
2	Removal of original air cleaner assembly and installation of replacement components	1.5
3	Installation of raised air intake assembly	1.0

6.1 The following modification items are to be demanded quoting this instruction as authority for demand:

Item (1)	DMC (2)	NSN/Part No. (3)	Designation (4)	Qty (5)	Remarks (6)
1	7XD	2940-99-790-4887	Intake air cleaner assembly, comprising:	1	Item 1 includes items 2 to 6
2	7XD	2940-99-352-4425	Filter element, outer	(1)	
3	7XD	2940-13-118-2077	Filter element, inner	(1)	
4	7XD	2940-99-225-8661	End cover assembly	(1)	
5	7XD	2940-99-932-7477	Vacuator valve	(1)	
6	7XD	5340-99-371-1301	Catch, clamping	(3)	
7	7XD	5340-99-152-1123	Bracket, mounting	1	
8	7XD	4330-99-958-0470	Interface bracket	1	
9	7XD	2940-99-391-1781	Kit, raised air intake, comprising:	1	Item 9 includes items 10 to 12
10	7XD	2940-99-269-1974	Kit, pre-cleaner	(1)	
11	7XD	2940-99-334-0103	Kit, down pipe	(1)	
12	7XD	2940-99-369-1422	Kit, air intake cowl	(1)	
13	7RU	2940-99-147-7417	Kit, blanking plate	1	
14	G1	5305-99-135-0268	Screw, countersunk	2	
15	G1	5310-99-122-3412	Washer, flat	4	
16	G1	5310-99-139-6098	Nut, 8 mm self locking	4	
17	G1	5305-99-122-8586	Bolt, 8 mm	2	
18	6MT1	5340-99-833-1816	Cable tie	A/R	See NOTE at Para 13

6.2 The following stores are to be disposed of locally:

Item (1)	DMC (2)	NSN/Part No. (3)	Designation (4)	Qty (5)	Remarks (6)
1	7XD	2940-99-850-3965	Air cleaner intake assembly	1	
2	7XD	5340-99-372-4325	Mount, resilient	4	Air cleaner
3	7XD	5305-99-500-5203	Screw, cap, hexagon head	1	Air cleaner
4	7XD	2940-99-930-7643	Grille, air intake	1	
5	7XD	5330-99-996-0513	Seal, non-metallic, shaped	1	Grille, air intake
6	7XD	5305-99-641-7463	Screw, machine	6	Grille, air intake
7	7XD	5310-99-551-2668	Washer, flat	6	Grille, air intake
8	7RU	5310-99-829-4335	Screw, tapping, thread forming	5	Grille, air intake
9	G1	5340-99-977-2493	Shield, expansion	5	Grille, air intake
10	7XD	5330-99-203-8377	Gasket	1	Grille, air intake

SEQUENCE OF EVENTS

7 Carry out this Preparation for Special Environment as follows:

TASK 1 ENGINE AIR CLEANER

CAUTIONS

- (1) **EQUIPMENT DAMAGE.** It is essential that all air cleaner hose connections and the cleaner end cover are secured correctly, to produce an airtight seal on the air cleaner casing.
 - (2) **EQUIPMENT DAMAGE.** The revised air cleaner contains two separate filter elements - one primary and one safety filter. The safety element is purely a back-up to the primary filter and protects the clean air ducting when the primary filter is out of the housing during servicing. The engine should NEVER be run with only the safety filter in place.
- 8 Remove the existing air cleaner assembly NATO Stock Number (NSN) 7XD/2940-99-850-3965 (AESP 2320-D-128-711 Chap 2-8-8 Fig 1 item 1).
- 9 Remove the two air cleaner mounting clamps NSN 7XD/5340-99-968-1898 (AESP 2320-D-128-711 Chap 2-8-8 Fig 4 item 6) and the four clamp rubber mounts NSN 7XD/5340-99-372-4325 (AESP 2320-D-128-711 Chap 2-8-8 Fig 4 item 7).
- 10 Remove screw NSN 7XD/5305-99-500-5203 (AESP 2320-D-128-711 Chap 2-8-8 Fig 4 item 3).
- 11 Using a suitable tool, drill a hole of 8.5 mm diameter in the mounting bracket NSN 7XD/5340-99-599-0128 (AESP 2320-D-128-711 Chap 2-8-8 Fig 4 item 1) at the position shown in Fig 1.

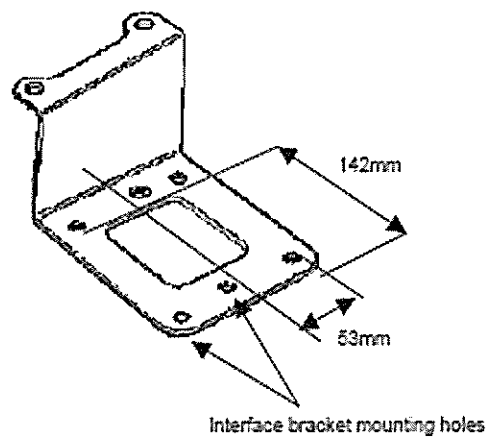

Fig 1 Air cleaner mounting bracket fitted to TUM/TUL HS

12 Fit the supplied interface bracket (item 8) to the mounting bracket as in previous para, using two 8 mm countersunk screws NSN G1/5305-99-135-0268 (item 14), flat washers NSN G1/5310-99-122-3412 (item 15) and self-locking nuts NSN G1/5310-99-139-6098 (item 16). The two lower 8 mm diameter holes in Fig 2 have a 15 mm diameter countersink applied. If required, the dimensions for the manufacture of the interface bracket are shown at Fig 2.

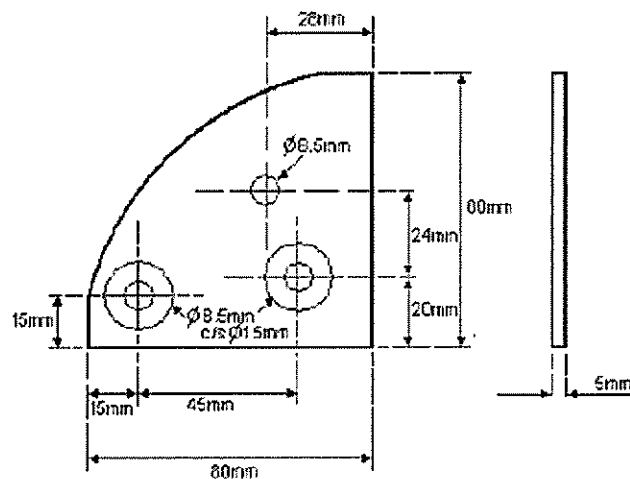

Fig 2 Interface bracket dimensions

13 Assemble the revised Donaldson air cleaner to the mounting/interface bracket using two off each 8 mm bolts NSN G1/5305-99-122-8586 (item 17), flat washers NSN G1/5310-99-122-3412 (item 15) and self-locking nuts NSN G1/5310-99-139-6098 (item 16).

NOTE

When the revised air cleaner is fitted, it has been intentionally designed to sit at an angle to the engine, as shown in Fig 3. Should difficulty be experienced in fitting the air hose to the filter assembly, the large cable tie securing the hoses together should be removed. This will allow the hose to be fitted, and then re-secured with cable tie (item 18), if the original is damaged.

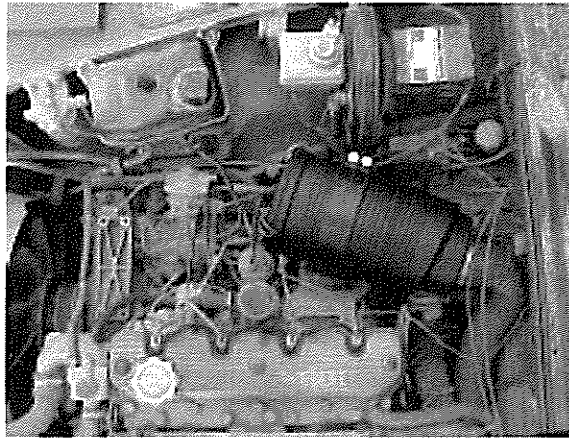

Fig 3 Revised air cleaner mounted at an angle to engine

14 Refit the air hose assembly to the air cleaner using the existing hose clip NSN 4730-99-464-7026 (AESP 2320-D-128-711 Chap 2-8-8 Fig 1 item 11).

15 It is essential to ensure that the revised air cleaner contains both filter elements - both the primary and safety are necessary for improved air filtration.

TASK 2 RAISED AIR INTAKE

NOTE

In conjunction with the fitting for the raised air intake, it is necessary to carry out fitting of an air intake blanking plate (see Task 4).

16 Locate and identify the Right Hand (RH) air intake. Clean all dust and debris from around the intake area.

17 Remove and retain the grille NSN 7XD/2940-99-930-7643, seal NSN 7XD/5330-99-996-0513 (AESP 2320-D-128-711 Chap 2-8-7 Fig 1 items 1/2), mounting screws NSN 7XD/5305-99-641-7463, and washers NSN 7XD/5310-99-551-2668 (AESP 2320-D-128-711 Chap 2-8-7 Fig 1 items 16/17).

18 Remove the five self-tapping screws NSN 7RU 5305-99-829-4335 (AESP 2320-D-128-711 Chap 2 8-7 Fig 1 item 18). If present, remove any locating dowels.

19 The inner air cowl is to be carefully dislodged from the inside of the wing, separated from the air intake duct and removed through the opening in the wing.

20 Remove the five captive nuts (shields, expansion) NSN G1/5340-99-977-2493 (AESP 2320-D-128-711 Chap 2-8-7 Fig 1 item 19) and gasket 7XD/5330-99-203-8377 (AESP 2320-D-128-711 Chap 2-8-7 Fig 1 item 4) from the inner cowl.

21 The outer air intake cowl attaches using screws to the inner cowl through the material of the wing. To facilitate this, it is necessary to install metal spire clips to the inner cowl. These spire clips will not fit without a slight modification to the cowl and removal of excess material.

22 Using a suitable tool, remove the excess material from where the original expansion shields have been removed as shown in Fig 4, so that the holes in the replacement metal spire clips align correctly with the original attachment holes in the cowl.

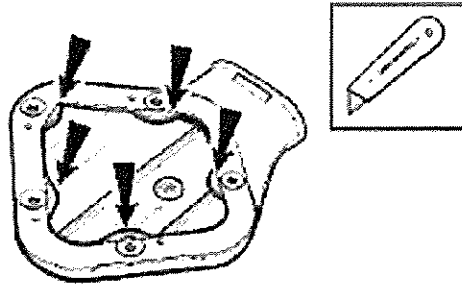

Fig 4 Trimming of excess material from inner duct

23 Attach the four spire clips ensuring that they are in the correct positions to align with the four holes in the outer cowl as at Fig 5. It is important to note that there are only four holes in the outer air intake cowl and it is attached using only four securing screws.

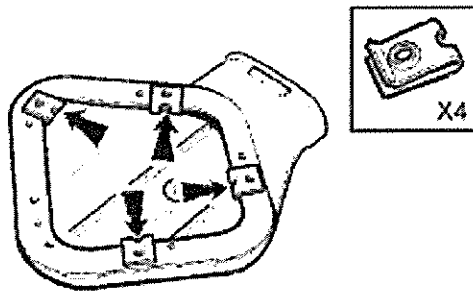

Fig 5 Fitting of spire clips

24 Pass the inner cowl through the opening and re-attach to the air intake duct. Ensure that a proper seal is achieved.

25 Using the supplied replacement gasket, align the inner cowl against the opening in the wing.

26 Attach the outer air intake cowl, ensuring that the second, larger gasket is inserted and correctly aligned, using screws and washers provided. It may be necessary to attach the outer air intake cowl by the shorter single screw to enable the location of the other three longer screws.

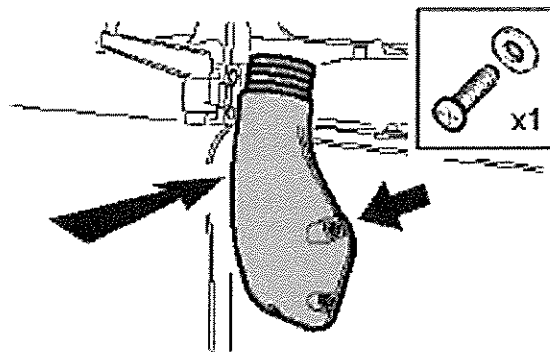

Fig 6 Attach outer duct by using single screw first

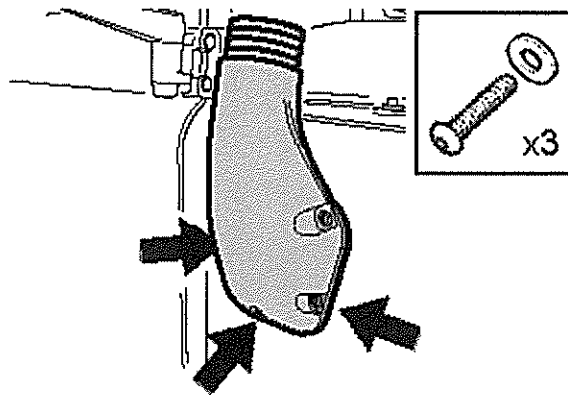

Fig 7 Attach outer duct with further 3 screws

27 The vertical down-pipe section of the raised air intake attaches to the windscreen 'A' pillar (unless VPK is fitted - in this case, see Task 3).

28 Remove the inner 'A' pillar moulding trim NSN 7RU/2510-99-788-8230 (AESP 2320-D-128-711 Chap 2-12-14 Fig 1 item 13) by removing the two self-tapping screws NSN G1/5305-99-788-7258 (AESP 2320-D-128-711 Chap 2-12-14 Fig 2 item 14).

NOTE

If the vehicle has front windscreen protection screen fitted (as introduced in AESP 2320-D-128-811 Modification Instruction No.18), carry out Task 3 completely so that the mounting bracket is attached to the vertical strut of the front frame assembly. This is in place of Paras 30 to 32. When Task 3 is complete, proceed to para 33.

29 Measuring from the bottom of the windscreen frame, measure upwards and mark at 145 mm, 245 mm and 345 mm as at Fig 8. These are the marks for the holes for the mounting bracket.

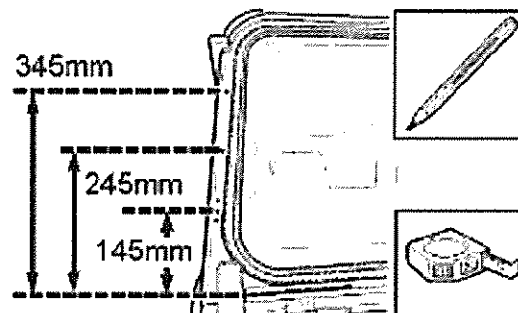

Fig 8 Mounting bracket drilling dimensions

30 Using the bracket as a template, confirm that the marks are in the correct position, and then drill three 5.5 mm diameter holes with a suitable tool.

31 Attach the bracket using the three supplied hex-headed thread-cutting screws, so that the protruding forward-facing flange is to the outside of the vehicle to facilitate the attachment of the upright pipe as at Fig 9.

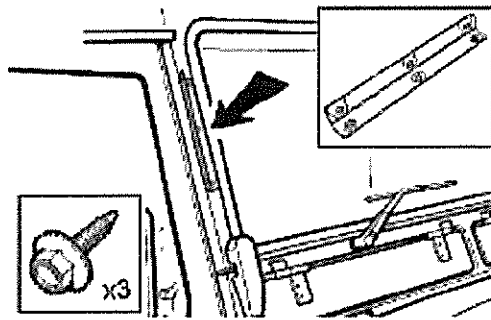

Fig 9 Bracket position

- 32 Refit the existing inner 'A' pillar moulding trim using the existing screws.
- 33 Attach the flexible hose assembly to the outer air intake cowl, ensuring a good seal.
- 34 Attach the upright pipe to the flexible hose assembly, again ensuring a good seal.
- 35 Secure the upright pipe to the bracket previously attached to the 'A' pillar, using the supplied nuts, bolts and washers as at Fig 10. The bolt should be inserted from the outside of the vehicle, with the smaller diameter washers adjacent to the bracket and the larger diameter washer adjacent to and clamping the moulded bracket of the upright pipe.

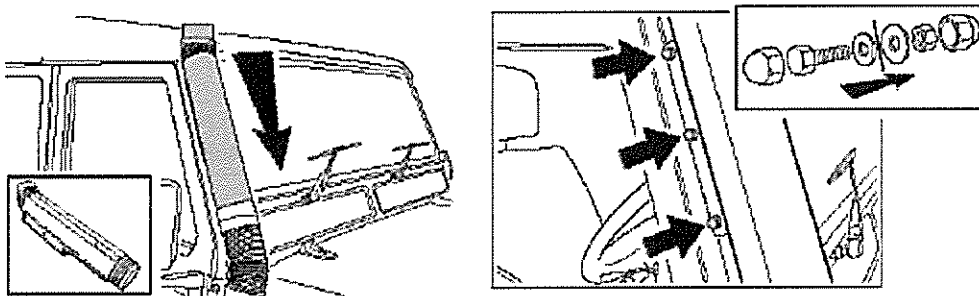

Fig 10 Attaching upright air intake pipe

- 36 Complete this section of the installation by attaching the six plastic dome covers.
- 37 Install the centrifuge insert firmly into the upper opening of the upright air intake pipe as at Fig 11.

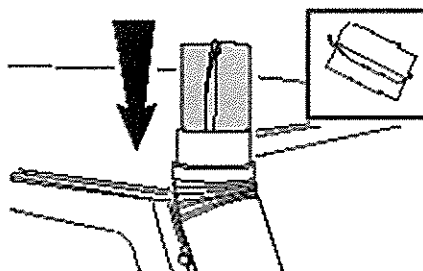

Fig 11 Installation of centrifuge insert

38 Align the pre-cleaner assembly to the centrifuge insert and carefully locate it as at Fig 12.

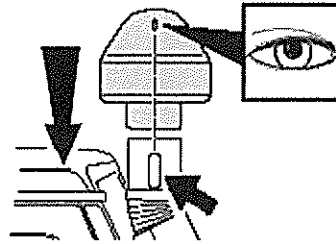

Fig 12 Pre-cleaner alignment

39 Using a suitable tool, drill two 5 mm diameter holes through the pre-cleaner and upright air intake pipe. Secure the pre-cleaner assembly with the two supplied pop rivets.

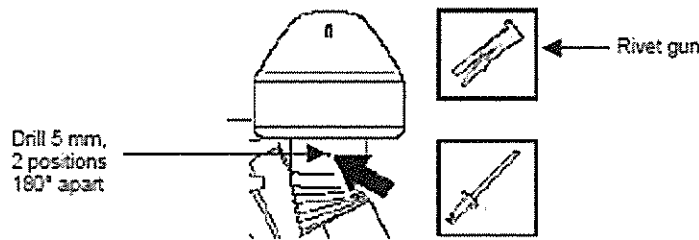

Fig 13 Attach pre-cleaner with pop rivets

40 Ensure that all sections of the complete raised air intake and all fixings are secure and tight, and that all seals are as airtight as possible.

TASK 3 RAISED AIR INTAKE WHEN VEHICLE PROTECTION KIT (VPK) IS FITTED

NOTE

This part of the Preparation for Special Environment deals with the minor differences when fitting the raised air intake to a vehicle with a VPK fitted.

41 When fitting the raised air intake, as in Task 2, to a vehicle with a VPK, it is necessary to fit the mounting bracket to the RH vertical upright of the front screen frame assembly rather than the vehicle 'A' pillar.

42 Take the lower mounting pin (through the hinge) as the lower baseline for measurements. Measure and mark at 100 mm spacing as per Fig 14.

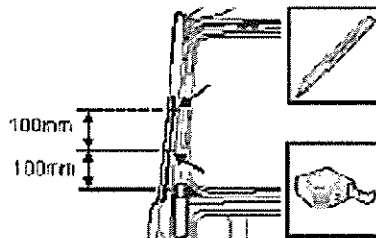

Fig 14 Mounting bracket drilling dimensions - when fitted with VPK

43 Using a suitable tool drill 7 mm diameter holes as marked.

44 Utilising the enclosed screws, bolts and flat washers, mount the bracket to the upright of the front screen frame assembly as per Fig 15.

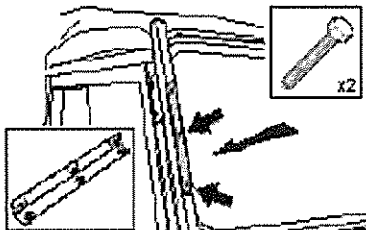

Fig 15 Mounting of adaptor bracket

45 When attaching the raised air intake, mount the intake down pipe to this bracket using the three enclosed M6 x 20 mm bolts, nuts and the six M6 flat washers.

TASK 4 AIR INTAKE BLANKING PLATE

NOTE

All TUM/TUL (HS) vehicles have two air intakes, one on either side of the vehicle, when fitting the raised air intake it is also necessary to fit a blanking plate to one original air intake. The Left Hand (LH) air intake must be blanked off using the supplied blanking plate.

46 Identify and locate the LH air intake grille NSN 7XD/2940-99-593-8653 (AESP 2320-D-128-711 Chap 2-8-7 Fig 1 item 7). Clean all dust and debris from around the intake area.

47 Remove the six screws NSN 7XD/5305-99-641-7463 and washers NSN 7XD/5310-99-551-2668 (AESP 2320-D-128-711 Chap 2-8-7 Fig 1 items 16/17).

48 Taking care not to damage the seal NSN 7XD/5330-99-996-0513 (AESP 2320-D-128-711 Chap 2-8-7 Fig 1 item 8), remove the air intake grille.

49 Remove the five self-tapping screws NSN 7RU/5305-99-829-4335 (AESP 2320-D-128-711 Chap 2-8-7 Fig 1 item 18).

50 Position the supplied blanking plate and gasket, and secure using the existing self-tapping screws.

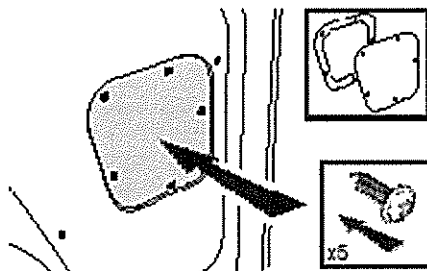

Fig 16 Secure blanking plate

- 51 Refit the air intake grille, utilising the existing seal and mounting screws.

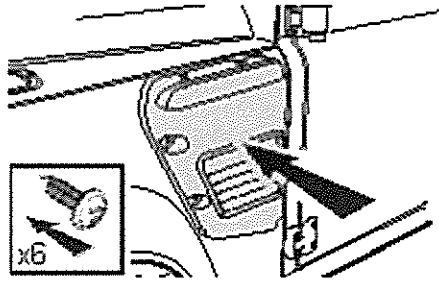

Fig 17 Refit air intake grille

MAINTENANCE INSTRUCTIONS

CAUTION

EQUIPMENT DAMAGE. The revised air cleaner contains two separate filter elements – one primary and one safety filter. The safety element is purely a back-up to the primary filter and protects the clean air ducting when the primary filter is out of the housing during servicing or if something goes wrong with the primary filter. The engine should NEVER be run with only the safety filter in place.

General

- 52 The design of the filter elements in the revised air cleaner will allow them to last as long as the original Land Rover filters, and as such should be maintained appropriately as per AESP 2320-D-128-601.
- 53 Additionally, it is necessary to replace the safety filter with every third primary filter change. This should be recorded in the vehicle docs.

Two-stage air cleaner maintenance instructions

- 54 Remove the end cover by unfastening the latches. As the filter fits tightly over the outlet tube to create the critical seal, there will be some initial resistance. Gently attempt to rotate the filter back and forth to break the seal, and when removing avoid knocking the filter against the housing.
- 55 Remove the safety filter using the same method as the primary filter, making sure that air cleaner outlet tube is covered to avoid ingress of unfiltered contaminant. Only remove the safety filter element if it is being replaced.
- 56 Use a clean cloth to wipe the filter sealing surface and the inside of the outlet tube. Contaminant on the sealing surface could hinder an effective seal and cause leakage. Make sure all contaminant is removed before the new filter is inserted. Be careful not to damage the sealing area on the tube.
- 57 Inspect the old filter element for any signs of leaks. A streak of dust on the clean side of the filter is a telltale sign, and any cause of leaks must be rectified before installation of the new element.
- 58 Inspect the new filter carefully for signs of damage, paying particular attention to the inside of the open end, which is the sealing area. Never install a damaged filter.
- 59 If the safety filter is to be replaced, ensure that this is firmly in position before installing the primary filter. Insert the new primary filter carefully, seating it by hand, making certain it is fully into the air cleaner housing before the cover is secured.

60 The critical sealing area will stretch slightly, adjust itself and distribute the sealing pressure evenly. To complete a tight seal, apply pressure by hand to the outer rim of the filter, not the flexible centre. Avoid pushing on the centre of the urethane end cover - no cover pressure is needed to hold the seal. Never use the end cover to push the filter into place, as this could cause damage to the filter and the housing. If the cover contacts the filter before it is fully in place, remove the cover and push the filter further into the air cleaner by hand, and try again. Once the filter is in place, fit and secure the end cover using the clips.

61 Once the filters and end cover are in place, ensure that all mounting bands, clamps, bolts and all connections in the air cleaner system are tight. Check for holes in piping and make the necessary repairs. Any leaks in the air intake piping will cause ingress of dust directly into the engine.

TRUCK UTILITY LIGHT (TUL), HS TRUCK UTILITY MEDIUM (TUM) HS

AND (TUM) BATTLEFIELD AMBULANCE HS

PREPARATION FOR SPECIAL ENVIRONMENT INSTRUCTION NO. 5

WATERPROOFING INSTRUCTIONS FOR WMIK VARIANTS

SUBJECT: WATERPROOFING INSTRUCTIONS STAGE 'B', STAGE 'C', AND STAGE 'D'

CANCELLATION

INTRODUCTION

1 Preparation for Special Environment Instruction No 5, Waterproofing Instructions for Weapons Mount Installation Kit (WMIK) Variants. The WMIK Variants are now subject of a separate set of AESP Publications.

ACTION

2 File this Page in place of Instruction No 5 dated Feb 05, all pages of which are to be destroyed.

PAGE LEFT INTENTIONALLY BLANK