

SERIOUS INCIDENT

Aircraft Type and Registration:	DHC-8-402, G-FLBE
No & Type of Engines:	2 Pratt & Whitney Canada PW150A turboprop engines
Year of Manufacture:	2009 (Serial no: 4261)
Date & Time (UTC):	14 November 2019 at 1950 hrs
Location:	In-flight from Newquay Airport to London Heathrow Airport
Type of Flight:	Commercial Air Transport (Passenger)
Persons on Board:	Crew - 4 Passengers - 59
Injuries:	Crew - None Passengers - None
Nature of Damage:	Aileron cable broke
Commander's Licence:	Airline Transport Pilot's Licence
Commander's Age:	51 years
Commander's Flying Experience:	8,778 hours (of which 5,257 were on type) Last 90 days - 150 hours Last 28 days - 33 hours
Information Source:	AAIB Field Investigation

Synopsis

Shortly after takeoff in a strong crosswind, the pilots noticed that both handwheels¹ were offset to the right in order to maintain wings level flight. The aircraft diverted to Exeter Airport where it made an uneventful landing.

The handwheel offset was the result of a break in a left aileron cable that ran along the wing rear spar. In the course of this investigation it was discovered that the right aileron on G-FLBE, and other aircraft in the operator's fleet, would occasionally not respond to the movement of the handwheels. Non-reversible filters were also fitted to the operator's aircraft that meant that it was not always possible to reconstruct the actual positions of the control wheel, column or rudder pedals recorded by the Flight Data Recorder.

The aircraft manufacturer initiated safety actions to improve the maintenance of control cables and to determine the extent of the unresponsive ailerons across the fleet. Three Safety Recommendations are made in this report for the unresponsive aileron and filtering of the control position data.

Footnote

¹ The handwheel is also commonly referred to as control wheel or yoke. In this report the term handwheel is used.

History of the flight

The pilots were operating a four-sector duty with two return flights from Newquay Airport (Newquay) to London Heathrow Airport (Heathrow). The first sector was uneventful, and the pilots reported no technical issues with the aircraft. On the second sector, the weather reported at Newquay was strong northerly winds with turbulence at lower levels and a gusting crosswind that would have been close to the aircraft's limit² of 32 kt. The aircraft landed at 1723 hrs.

The commander considered that the landing at Newquay was firm and was concerned that it may have constituted a heavy landing, so called for engineering assistance. The operator's Maintenance Control checked the flight data from the aircraft's wireless Quick Access Recorder and dispatched an engineer to examine the aircraft. The pilots were subsequently informed that the landing had been within limits and the aircraft departed for Heathrow around 25 minutes late at 1914 hrs.

Due to the strong gusting wind conditions, the plan was for the commander to act as PF for the departure with the co-pilot assuming control once airborne. Routine control checks were carried out during the taxi and appeared to be normal. The pilots described the conditions during the departure as "quite rough with a lot of drift". At the acceleration altitude of 1,000 ft aal, the commander engaged the autopilot (AP) and passed control to the co-pilot who made a right turn, using the AP, towards the reporting point DAWLY.

The co-pilot stated that he felt that the aircraft "struggled" to maintain the right turn. He, therefore, informed the commander that there was an issue with the controls and that the handwheel was deflected significantly to the right to maintain wings level. The commander, who had not noted any difficulty in controlling the aircraft in manual flight, recalled that the handwheel was not in the correct position and was displaced to the right by around 30° to 40°. He also reported that the trim was in the normal position and the spoilers were retracted.

The commander took control and noted that the displacement of the handwheel was the same with the AP disengaged, and when flown manually the aircraft felt in trim with no unusual feedback through the controls. The AP was reselected, and control passed back to the co-pilot. The pilots discussed the issue and decided to stop their climb at FL200. The co-pilot recalled that the handwheel deflection increased with increased airspeed, which he considered was due to the scheduled de-activation of the outboard spoilers at 170 KIAS.

The commander contacted his company operations to seek engineering advice. As the response did not help his understanding, he informed operations of his intention to divert to Exeter Airport (Exeter) as it was a company engineering base. He requested a direct track to the EX NDB, which was approved by ATC, and the commander briefed the cabin crew on the situation. As the aircraft descended towards the NDB the co-pilot noticed that the control deflection required to maintain wings level was increasing. During this period, the pilots consulted the Quick Reference Handbook (QRH) but found no checklists that they

Footnote

² The crosswind limit is for wet and dry conditions.

considered relevant. As the aircraft neared the NDB the cabin was not ready for landing, so the commander decided to join the Hold. As the airspeed reduced, the outboard spoilers became active and the crew recalled that the handwheel deflection reduced. The crew declared a PAN to Exeter ATC.

The commander stated that as the handwheel was deflected to the right, it would be preferable to fly left turns and, therefore, made this request to ATC. Once the cabin was secured, the aircraft was positioned for a left-hand downwind leg for an approach to Runway 08 with the commander as PF. The weather conditions at Exeter were better than at Newquay with only a slight crosswind from the left during the approach. The commander deselected the AP earlier than normal and recalled a slight pull to the right on the handwheel, but felt the aircraft was completely controllable. The approach and landing were uneventful, and the aircraft landed at 1955 hrs.

Aircraft damage

Post-flight examination revealed that the lower left aileron cable broke just outboard of the engine where it passed over a pulley to accommodate a change in the wing dihedral (Figure 1). There was no other damage to the aircraft.

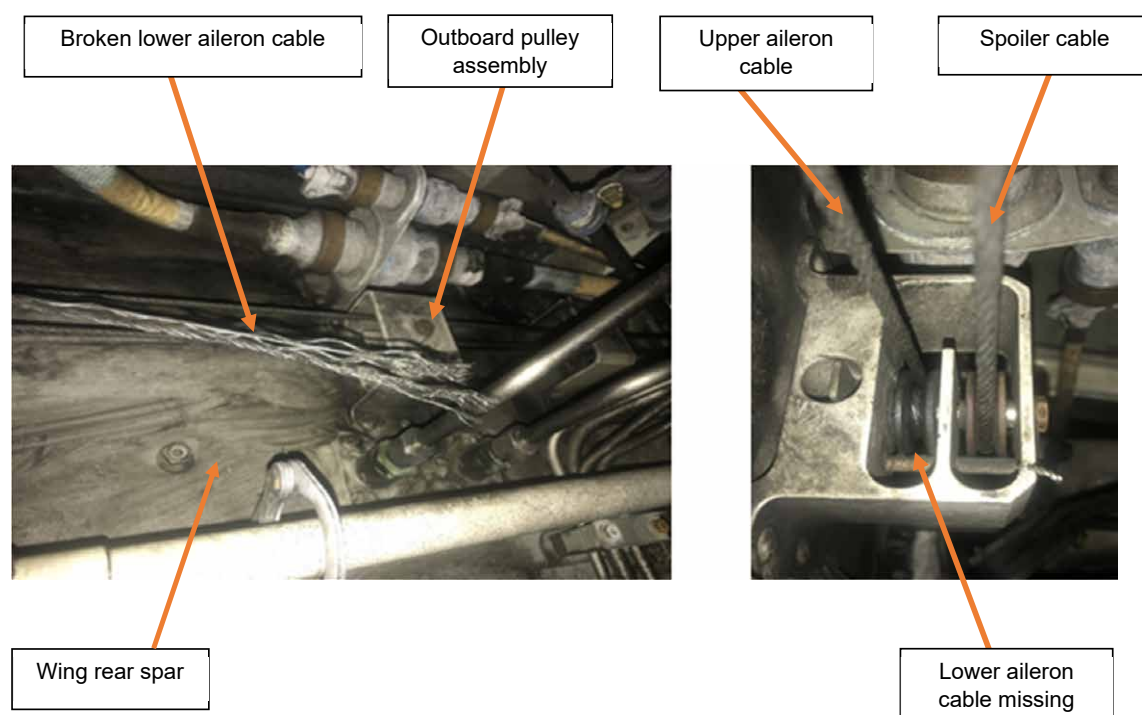

Figure 1

Broken aileron cable and associated pulley

Personnel information

Both pilots were experienced, with the co-pilot recently having been employed as a direct entry commander: the operator required direct entry commanders to operate as a co-pilot for three months prior to transitioning to command.

Aircraft information

The De Havilland Canada Dash 8-402 (DHC-8-400³) is a high wing, two pilot, transport category aircraft, with seating for up to 78 passengers and powered by two turboprop engines.

G-FLBE was manufactured in 2009 and had accrued approximately 22,400 flying hours. It was certified against the requirements of Canadian Airworthiness Manual 525, which is applicable to Transport Category Aeroplanes.

Aircraft roll control systems

Roll control is achieved using a combination of ailerons and spoilers.

Ailerons

Roll inputs are mechanically transmitted from the pilot's handwheels to the ailerons through a series of quadrants, cables, levers and pushrods. Movement of the handwheels causes the ailerons to deflect asymmetrically and in proportion to the handwheel rotation. Aileron position is not shown on the cockpit instrumentation.

Spoilers

The spoilers are a secondary flight control system. There are two hydraulically powered spoilers on each wing identified as inboard and outboard. The inboard spoilers operate across the full speed range; the outboard spoilers are automatically de-activated above 170 kt and are reactivated as the aircraft decelerates through 165 kt. The position of all four spoilers is shown on the cockpit instrumentation.

Autopilot and trim

The Automatic Flight Control System provides roll commands through the AP servo. The AP automatically disconnects if the force at the handwheel exceeds approximately 17.5 lb.

Roll disconnect system

The left pilot's handwheel is connected to the spoiler control circuit and the right pilot's to the aileron control circuit. Under normal operations the handwheels are connected to each other so that either handwheel operates both circuits at the same time. If either control circuit becomes jammed, a roll disconnect handle in the cockpit can be operated to disconnect the aileron system from the spoiler system. The pilot with the unjammed controls would then control the aircraft in roll.

Aileron and spoiler control cables on the wing rear spar

The aileron and spoiler control cables are routed along the wing rear spar. These control circuits are closed-loops⁴ consisting of upper and lower cables with turnbuckles to set a

Footnote

³ In this report, DHC-8-400 is used to refer to the -402 and other derivatives of the -400 series of aircraft.

⁴ Closed-loop in this sense refers to a flying control system with two cables in tension such that when one cable moves, the other cable remains in tension but moves in the opposite direction. The flying control surface is attached to both cables.

nominal tension of 97 lb (+/- 2.5 lb) adjusted in accordance with the AMM for variations caused by the local air temperature. There is no other cable tensioning device in either control system.

Immediately outboard of the engine, small pulleys direct the cables by approximately three degrees to accommodate a change in the wing dihedral. The spoiler cables are routed aft of the aileron cables (Figure 2).

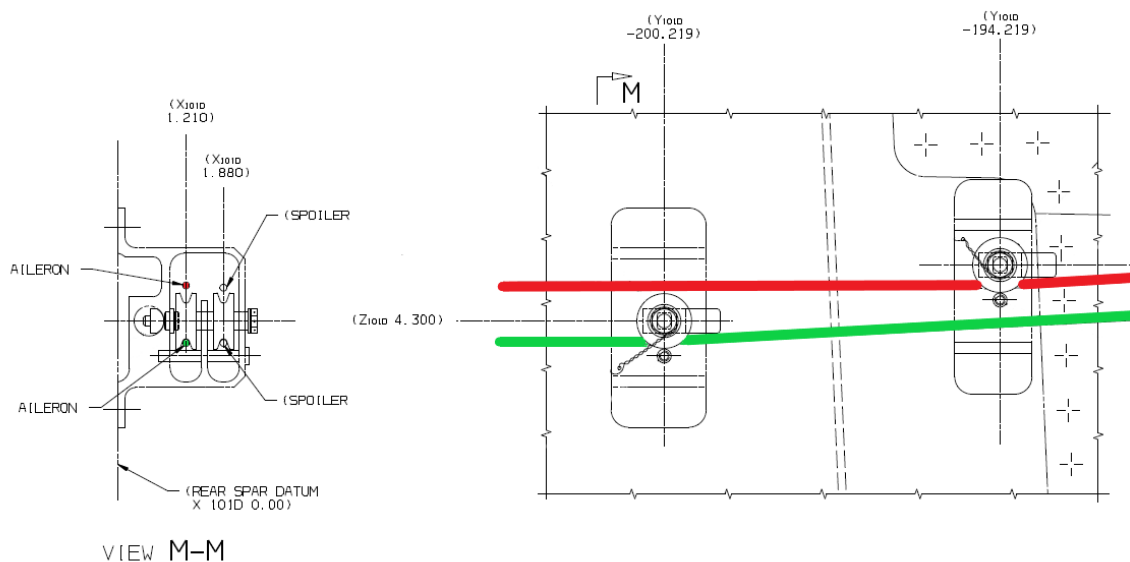

Figure 2

Pulley and cable arrangement to accommodate a change in the wing dihedral

Construction of the control cables

The control cables have a diameter of $\frac{1}{8}$ inch and are constructed from 7 strands, each consisting of 19 wires. Six of the strands are wound concentrically around a central strand (Figure 3).

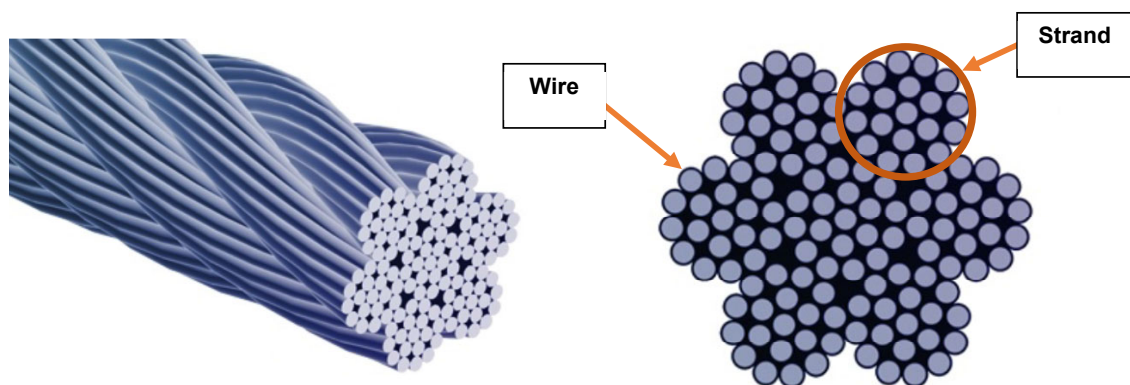

Figure 3

Construction of the control cable

Meteorology

The Met Office provided the following summary of the weather at Newquay for when G-FLBE departed at 1914 hrs:

'From the information available, it can be concluded that the meteorological conditions on the 14th November 2019, in the area around Newquay at around 1900 UTC, were strong winds with a band of cloud and rain. The observational data shows evidence that at the time of departure, surface wind speeds were 22-24 KT with gusts 32-36 KT at 020 degrees. Forecast data from both the F214 and Ballooning forecast also indicate that likely wind speeds at 500 and 1000 FT would have been around 30 KT and 40 KT respectively. Forecast data from the F215 low level weather chart indicated that at the time of interest there would likely have been moderate to severe low-level turbulence in the vicinity of Newquay.'

Relevant QRH checklists

The pilots consulted the operator's QRH during the transit to Exeter but did not find any checklists that they considered relevant. However, the QRH contains a checklist for *'Roll Control Malfunction - Aircraft rolls with no Control Wheel [Handwheel] Input'* (Figure 4), which the manufacturer advised was relevant.

ROLL CONTROL MALFUNCTION (Aircraft rolls with no Control Wheel input)	
• Roll Control.....	APPLY TO HOLD WINGS LEVEL
IF CONTINUOUS ILLUMINATION OF SPLR 1 OR SPLR 2 PUSH OFF SWITCHLIGHTS IN WINGS LEVEL FLIGHT:	
• Illuminated Switchlight.....	PUSH OFF
OTHERWISE, IF SPLR 1 OR SPLR 2 PUSH OFF SWITCHLIGHTS DO NOT ILLUMINATE:	
• Power.....	APPLY
• Airspeed.....	INCREASE
IF SPLR 1 OR SPLR 2 PUSH OFF SWITCHLIGHTS PUSHED OFF:	
Note » The SPLR OUTBD caution light will illuminate below 150 KIAS, the ROLL SPLR INBD GND and ROLL SPLR OUTBD GND caution lights will illuminate on landing.	
LANDING CONSIDERATIONS:	
» Land at an airport with minimal crosswind and turbulence using flap 15 or 35.	
» Landing distance – Page 2.3 Non-Icing, 3.3 Icing – Item 5	
• END	
OTHERWISE:	
LANDING CONSIDERATIONS:	
» Land at an airport with minimal crosswind and turbulence using flap 15 or 35.	
» Non-Icing and Icing V _{APP} and V _{REF} speed increase by 7kts.	
» Landing distance – Page 2.3 Non-Icing, 3.3 Icing – Item 6	

Figure 4

QRH Roll Control Malfunction checklist

The pilots stated that the handwheel had to be displaced by up to 40° to the right to maintain level flight, which can be considered as an uncommanded roll to the left. The checklist commences with an action on Roll Control and states '*APPLY TO HOLD WINGS LEVEL*'. The next action concerns the spoilers and, as was the case on the event flight, if the SPLR 1 or SPLR 2 captions have not illuminated the pilots are instructed to apply power and increase airspeed, but are not advised by how much. The manufacturer advised that the intent of increasing airspeed is to improve roll authority with the remaining controls.

The second part of the checklist addresses the landing considerations and directs the crew to land at an airport with minimal crosswind and suggests the use of either Flap 15 or 35. However, the manufacturer stated that any allowable landing Flap setting would be acceptable and the aircraft was cleared to land with Flap 10, 15 or 35; it was only the operator's version of the QRH that restricted the choice of Flap. The manufacturer advised that consideration of minimal crosswind was a generic expression that they used in a number of checklists and the intention was to remind pilots to consider the 'retained lateral control authority for landing'. Therefore, commanders should select an airfield which has the lowest crosswind component.

The checklist also directs the pilots to use the non-normal Landing Distance Required (LDR) table in the QRH. As the pilots felt that the QRH was not relevant, they did not complete these actions and instead used the normal V_{REF} ⁵ and landing distance. The runway at Exeter was sufficiently long for the increased LDR.

Recorded information

Recorders

The aircraft was fitted with a Flight Data Recorder (FDR), QAR and a 120-minute duration Cockpit Voice Recorder (CVR). The FDR recorded the incident flight and 23 previous flights. The CVR recording of the flight had been overwritten because the circuit breakers for the electrical power supply had not been pulled after the aircraft landed as the operator initially considered that the event was not reportable to the AAIB.

Salient parameters on the FDR included the position of the handwheels and control columns⁶, the inboard and outboard spoilers and the right aileron. The Regulator did not require the left aileron to be instrumented as it is possible, during normal operation, to derive its position from the right aileron.

Previous landing at Newquay Airport

During the approach and landing at Newquay there were fluctuations in the aircraft's airspeed, roll and pitch, with rapid movements of the handwheels to maintain a wings level attitude. This movement was consistent with the turbulent weather conditions. As

Footnote

⁵ V_{REF} is the Reference Landing Approach Speed. The speed of the aircraft when it is at a height of 50 feet above the landing runway threshold if the calculated landing performance is to be achieved.

⁶ The left and right handwheel positions are required to be recorded because the left and right controls may be disconnected from each other in flight.

the aircraft touched down, a peak normal load of 2.01 g was recorded (a heavy landing inspection is required if the normal load exceeds 2.10 g). The aircraft briefly bounced before touching down for a second time with a normal load of 1.54 g, following which it then settled on its landing gear.

There was no offset in the handwheels during the flight from Heathrow to Newquay.

Flight from Newquay to Exeter

During the takeoff and initial climb from Newquay, the handwheels were at an average position of 23° clockwise (CW) to maintain a wings level attitude. An average handwheel position of 4° CW was required to maintain wings level during the two previous takeoffs from Newquay earlier the same day using the same runway. The wind speed and direction⁷ were similar during all three takeoffs.

As the aircraft climbed through 1,000 ft aal, the AP was engaged (Point A Figure 5) and the aircraft started the right turn (Point B Figure 5), initiated by the pilots, towards DAWLY. When the aircraft's airspeed increased to 170 kt the outboard spoilers automatically deactivated and moved to their stowed positions. At 6,000 ft the aircraft rolled wings level, but the handwheels remained at about 20° CW (Point C Figure 5). The right aileron and right inboard spoiler were at +6° and 8° respectively (full range of aileron and spoiler movement is +/-17° and 75° respectively).

The full range of movement of the handwheels is 140° (70° CW and 70° anti-clockwise from the neutral position). Therefore, at 20° the handwheels were at 28% of their full CW range of movement. About 30 seconds later, the AP was manually disconnected as the commander assessed the roll control of the aircraft. The AP was then engaged, and the aircraft subsequently levelled at FL200.

At 1930 hrs, the aircraft altered course towards Exeter. While descending, the aileron trim was adjusted but this did not alter the CW handwheel offset. The aircraft entered a left descending Hold before positioning onto a left downwind approach. During these left turns, which were flown at airspeeds of between 200 kt and 187 kt, the handwheels were at 33° CW to maintain a left bank of 30°. As the aircraft's airspeed reduced below 165 kt, the outboard spoilers assisted with roll control.

When configured for landing with Flap 35 set and an approach speed of 123 kt, the handwheels were at 10° CW to maintain a wings level attitude. The AP was disconnected at 800 ft aal and the aircraft made an uneventful landing.

Modelling carried out by the manufacturer showed that the position of the left aileron and handwheel was dependent on a number of factors including the aircraft speed and direction of turn. When the handwheel was moved to the left, the intact cable on the left aileron would pull the surface upwards, but when moved to the right the tension in the

Footnote

⁷ The reported wind during the event was from 010° at 23 kt, gusting 39 kt, and the wind during the previous departures had been from 020° at 24 kt, gusting 36 kt, and from 010° at 20 kt, gusting 30 kt.

intact cable would reduce and the aileron would be moved by aerodynamic loads. The manufacturer confirmed that the aircraft had sufficient roll authority with the left aileron in the most adverse position.

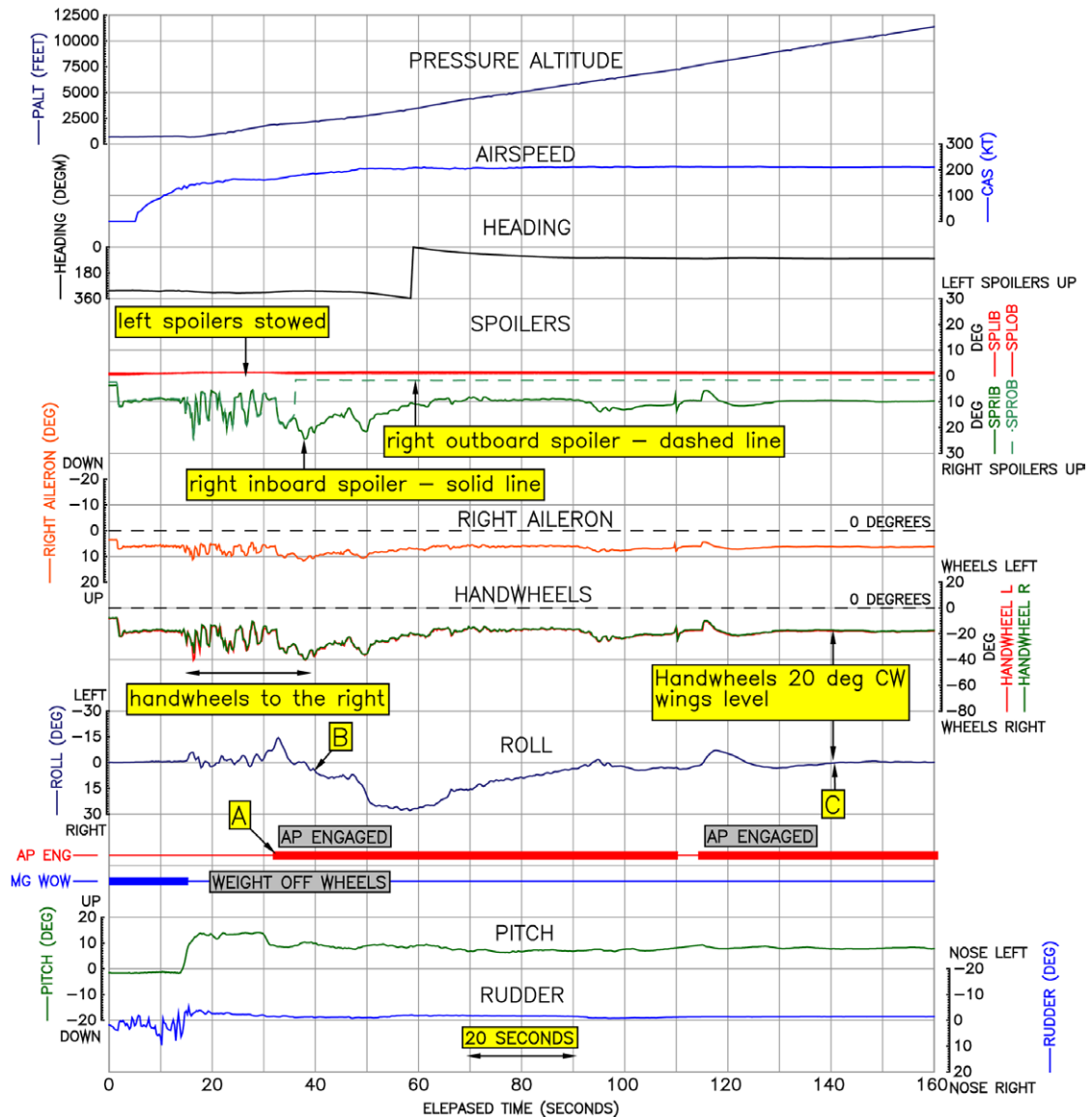

Figure 5

Handwheel offset after departing Newquay

On-aircraft examination

The lower left aileron cable failed where it passed over a pulley mounted on the rear wing spar. The pulley was found to rotate freely on its bearing.

When the handwheels were rotated through their full range of movement, the right aileron operated normally, whereas the left aileron remained in the fully up position. When the outboard section of the broken cable was pulled, the left aileron moved towards the neutral position and when released returned to the up position.

The broken cable was dirty and left a residue on a cloth when it was wiped. It was noted that there was a heavy accumulation of dirt on both sides of the aircraft where the aileron and spoiler cables ran along the inboard section of the rear spar. This heavy accumulation of dirt was also present on other aircraft in the operator's fleet.

Detailed examination of the cable and pulley

The cable and its associated pulley were examined using optical and scanning electron microscopes. Individual wires showed a variety of features including ductile (tensile overload) failure, wear between wires in adjacent strands, wear between wires in the same strand and wear from an external source. There was no evidence of manufacturing anomalies, corrosion or fatigue.

The pulley was found to be worn with a pronounced imprint of the cable around the entire circumference of the groove. Small particles of metallic debris were found embedded in the pulley and it was concluded that these originated from the control cable. Apart from the wear, dimensional checks of the pulley found it to be compliant with the drawing requirements.

G-FLBE maintenance history

The aileron cable had been fitted for six years and flown approximately 13,000 hours; it was visually inspected on five occasions. The last inspection was completed 10 months and 1,100 hours before the failure, when the tension of all four aileron cables on the rear wing spars was found to be below the minimum requirement. Maintenance records show that the cables were re-tensioned in accordance with the Aircraft Maintenance Manual (AMM).

Maintenance of cables

Aileron and spoiler control cables are 'on-condition'⁸ and subject to a visual inspection and tension check every 2,500 hours. Preparation for this inspection includes removing external visible grease and dirt from the contact areas using a clean, dry cloth and a nylon brush with short bristles. If wear or fraying exceeds the limits defined in the AMM, and repair drawing, the cable must be replaced. If a new cable is installed the associated pulley can be re-used provided there are no flat spots on the groove and the pulley rotates freely.

There is no requirement to record the cable tension for trend monitoring and if cables are found to have insufficient tension the procedure instructs the maintainer to tighten the cable as required. There is no requirement in the AMM for operators to investigate the loss of tension, which might be indicative of a problem with the affected cable.

With regard to investigating the loss of cable tension, the Australian Civil Aviation Safety Authority issued a general Airworthiness Bulletin 27-012⁹ in 2011 which advised:

Footnote

⁸ On-condition is preventive maintenance that requires a system, component, or appliance be inspected periodically or checked against some appropriate physical standard to determine if it can continue in service. The standard ensures that the unit is removed from service before failure during normal operation.

⁹ <https://www.casa.gov.au/files/awb-27-012-issue-1-aircraft-control-cable-systems> (Accessed 13 March 2020).

'...maintenance personnel and operators to be vigilant whenever installing or adjusting any aircraft control system using the classic two cables in tension, closed-loop cable design, including primary flight control systems.'

'loss of control cable tension should be treated with suspicion and investigated as it could be an indication of incorrect assembly and impending failure.'

Manufacturer's previous actions to address cable wear

2004

In April 2004, the aircraft manufacturer issued an All Operators Message (AOM) 122¹⁰, which advised that premature wear had been found in the aileron and spoiler control cables that run along the wing rear spar. The AOM cited two main causes: excess grease and low cable tension. Following these findings, the cable manufacturing process was modified to prevent the application of excess grease, and the aircraft maintenance procedures¹¹ were amended to increase the pre-stretch loading¹² of the cables prior to final tensioning.

In December 2004, the manufacturer issued Service Bulletin (SB) 84-27-26¹³ to inspect aileron and spoiler cables for premature wear, excess grease and correct tension. Operators were asked to report back on damaged or worn cables. The SB required:

- Any cables that were found to be worn beyond the limits defined in the AMM¹⁴ to be replaced.
- Any excess grease to be removed using a dry cloth.
- Cable tension to be checked and adjusted as necessary.

2007

In May 2007, AOM 224 was issued which highlighted that little feedback had been received in response to SB 84-27-26. One operator reported finding one 'severely worn' aileron cable and 17 of their 23 aircraft had at least one cable with wear beyond the allowable limits. In all cases the cable tension was below the limits specified in the AMM.

The AOM informed operators that the AMM had been amended to include cold weather tension limits and suggested that operators consider implementing a summer and winter check of the cable tensions on the wing rear spar. Operators were also advised that if the

Footnote

¹⁰ Bombardier Q400 All Operators Message No. 122, Special Inspection of Aileron and Spoiler Control Cables.

¹¹ Q400 Aircraft Maintenance Manual Task 27-10-00-830-805, Aileron Splitter Quadrant to Aileron Terminal Quadrant Rigging.

¹² A cable will stretch when a load is applied. The amount of stretch depends on the elasticity of the material and the construction of the cable. Provided the elastic limit is not exceeded, the elastic component of the stretch will disappear when the load is removed. The stretch associated with the construction of the cable is variable and remains when the load is removed. Pre-stretching is the application of a defined load to allow the cable to settle before the final load is applied.

¹³ Bombardier (de Havilland DASH 8) SB 84-27-26, Flight Controls – Aileron System and Spoiler System – Control Cable Wear – Special Inspection / Rectification.

¹⁴ Q400 Aircraft Maintenance Manual Task 20-10-21-200-801, Inspection of Seven-by-Nineteen and Seven-by-Seven Control Cables.

cables had not been checked within the previous 24 months they should consider performing an inspection in accordance with SB 84-27-26. A repair drawing was issued to allow aileron cables, where the damage exceeded the limits in the AMM, to continue operating with up to 12 broken wires for another 500 hours subject to an inspection every 65 hours (L-check). This inspection period was reduced in 2015 to 50 hours.

In July 2007, AOM 228 was issued and explained why the cables that run along the rear wing spar are unusually susceptible to wear. The major contributing factors were listed as:

- Cable tension below the rigging requirement.
- Greater exposure to dirt and carbon brake dust thrown up by the landing gear.
- High vibration levels due to their proximity to the engine nacelle.

The AOM reported that the periodic visual inspection of the aileron and spoiler cables in this area had been reduced from 8,000 to 2,500 hours. A cable tension check, every 2,500 hours, had also been introduced.

2015

In December 2015, SB 84-27-68 introduced modified aileron and spoiler cables with the aim of reducing wear and extending the inspection interval. Modified cables have external polymer sleeves fitted over the sections that are in contact with the pulleys; modified pulleys were also introduced to accommodate the increase in diameter of the cable resulting from the addition of the sleeve. Embodiment was at the operator's discretion; modified cables had not been fitted to G-FLBE. Aircraft delivered from the manufacturer since December 2015 have the modified cables fitted.

Manufacturer's investigation

Examination of pre-modification aileron cables

The manufacturer reviewed the AAIB findings and examined two pre-modification aileron cables that were removed by the operator during their fleet inspection. They reported that both cables were excessively contaminated with grease and debris, and commented that this contamination would accelerate the wear of the cable strands [wires].

The manufacturer identified eight events where aileron cables had broken; three were identified because of anomalies in-flight and five were identified while the aircraft was on the ground. These events occurred between 2004 and 2019 and involved operators located in five different countries.

Examination of post-modification aileron cables

Examination of a post-modification aileron cable, that had accrued approximately 4,800 hours, found that the section of the cable under the polymer sleeve was clean with no evidence of contamination. Moreover, when the cable was sectioned, and examined in detail, there was little evidence of wear.

The manufacturer stated that there had been no operator-initiated returns of post-modification aileron cables apart from those returned as part of their sampling programme. Three operators participated in this programme with aileron and spoiler cables being examined after 4,000, 8,000, 12,000 and 16,000 hours in-service use. The manufacturer stated that the sampled cables showed no evidence of wear.

Rejection rates of aileron and spoiler cables

The manufacturer reported that the in-service rejection rate for spoiler and aileron cables was similar, but they had not been notified of any spoiler cables failing (breaking). A possible reason was that as the ailerons are reversible¹⁵ control surfaces, the cables experience more cycles of small movements.

Loss of cable tension in-flight

With regard to a loss of cable tension in-flight, the manufacturer advised:

'As a characteristic of Dash 8 aircraft design, aileron wing cable tension decreases at higher altitude. Flight tests in 2009 with instrumented turnbuckles showed as much as 55% tension loss at max altitude. If the cable had marginal tension on the ground (either through lack of maintenance or due to broken strands), the tension could drop to zero in-flight.'

Safety action

Following the event on G-FLBE, the manufacturer reviewed the periodic inspection procedure and proposed amendments. These included requirements to:

- Rub the cables with a clean cloth in both directions to catch on broken wires.
- Move the handwheel through its full range in order to ensure that the section of the cables that run along the rear wing spar can be examined.

The original procedure stated that the handwheel should be moved '*if necessary*' but it is not possible to see all the surfaces of the cable without moving the handwheel. The manufacturer anticipated that these safety actions would be completed during 2020.

Implications of a broken aileron cable

Effect on aileron control surface position

On the ground, if the lower aileron cable breaks, the tension in the upper cable will cause the aileron to deflect upwards, and conversely, if the upper cable breaks the aileron will deflect downwards.

Following the failure of a cable in-flight, the position of the aileron surface would be dependent on the aerodynamic loads (speed of the aircraft). Modelling of the FDR data by the aircraft

Footnote

¹⁵ A reversible flying control system is a system where there is a direct link between the flying control surface and the pilot's controls. If the flying control surface is moved, the control input also moves.

manufacturer showed that the left aileron reached a “high trailing edge up” position during periods of the flight. This would result in an uncommand roll that requires corrective action by either the pilot or AP.

Severity of a broken aileron cable

Failure of an aileron control cable was assessed as Minor during the certification process where a Minor event is defined as:

‘...failure conditions that would not significantly reduce aircraft safety, and would involve crew actions that are well within their capabilities. Minor failure conditions may include, for example: a slight reduction in safety margins or functional capabilities, a slight increase in crew workload, such as routine flight plan changes, or some inconvenience to occupants.’

However, the flight test programme for the certification of the DHC-8-400 did not include flying with a disconnected aileron cable. Instead, aircraft performance and roll authority were evaluated by separating the handwheels, using the disconnect mechanism, and flying the aircraft using the spoilers while the co-pilot’s handwheel, which is connected to the ailerons, was held in an offset position.

Manufacturer’s risk assessment

The manufacturer conducted a risk assessment as part of this investigation. After considering the severity of the failure, and the number of reported arisings, they concluded that the risk associated with an aileron control cable failure was low.

Regulator’s review of the severity classification

Transport Canada analysed the FDR data from this event and concluded that *‘more than adequate control authority was available to the crew for continued safe flight and landing following the cable disconnect’*. The number of reported in-service arisings was within the certification requirements for a Minor event and they considered the manufacturer’s proposed changes to the maintenance of the cables to provide adequate mitigation. They confirmed that the severity classification of Minor, which was applied during certification, remained appropriate.

Safety action taken by the operator

The operator had installed post-modification cables on 24 of their aircraft and was in the process of modifying the remaining 30 aircraft in their fleet when the cable failed on G-FLBE. An inspection of the unmodified aircraft, carried out following the cable failure, identified 18 aileron cables and several pulleys that required replacing, which had a time remaining to the next scheduled inspection of between 550 to 2,000 hours.

When the operator inspected the three remaining aileron cables on G-FLBE after the failure, they assessed that they were all serviceable. However, when the cables were inspected again, as part of the ongoing investigation, the operator decided to replace them.

As a result of these findings the operator accelerated their cable modification programme with the intention of completing it by the end of 2020. In the interim they reduced the inspection period for pre-modification cables from 2,500 hours to 800 hours. However, the operator ceased trading before the investigation and cable modification programme was complete.

Other information

Aileron cable failures on Boeing 737 aircraft

In 1997, the National Transportation Safety Board (NTSB) investigated an event on a Boeing 737 aircraft where an aileron cable broke where it passed over a pulley in the right wing-root, mainwheel well¹⁶. The investigation found that the cable failed due to a combination of internal and external wear with a metallurgist estimating that over 90% of the cable's total cross-section had been removed by the internal wear. The investigation established that six other similar failures had occurred over a 10-year period.

The NTSB made several recommendations to the FAA and Boeing, which included the provision of advice to aircrew, the introduction of a cable life, and inspection methodology and periodicity. The latter included a Recommendation that:

'the inspection should include releasing cable tension to better detect cable wear and wire breakage and establishing a maximum allowable reduction in cable diameter where pulley contact occurs.'

Inspection procedures were amended to include rubbing a cloth along the length of the cable to catch on broken wires and a requirement to move the handwheel through its full range to expose parts of the cable that are hidden by the pulleys. Instructions for checking cable diameter wear were included as an option but the proposal that the tension be released prior to the cables being inspected was not incorporated.

Unresponsive aileron in-flight

Unresponsive aileron during event flight

During this investigation an issue, unrelated to the cable failure, was identified with the movement of the right aileron in-flight. Data from the FDR showed that shortly after G-FLBE levelled at FL200, the aileron stopped responding to movement of the handwheels (Point A Figure 6). This lasted for about five minutes, with the aileron remaining in an almost fixed position of +5°. During this period, the AP continued to maintain wings level with handwheel positions between 13° CW and 27° CW. The inboard spoilers continued to operate normally during the flight.

As the aircraft started its descent to Exeter, the movement of the aileron suddenly returned to normal (Point B Figure 6). This coincided with the handwheels being moved by the AP from 27° CW to 35° CW as the aircraft rolled out of a left turn.

Footnote

¹⁶ NTSB report SEA97IA219, Boeing 737-3T0, N13331, occurrence date 27 September 1997, <https://www.fss.aero/accident-reports/dvdfiles/US/1997-09-27-US.pdf> (Accessed 9 April 2020).

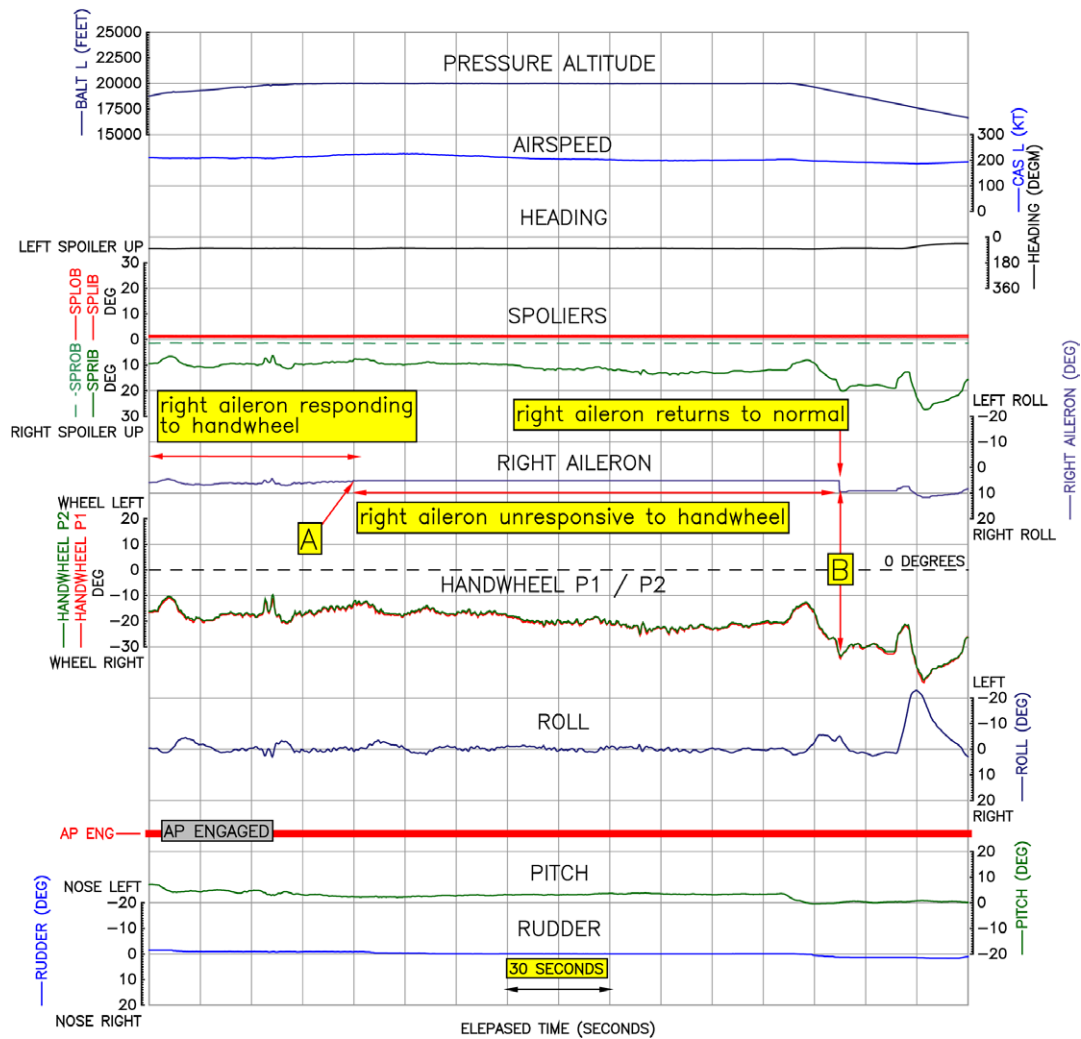

Figure 6

Unresponsive right aileron

Other occurrences of unresponsive ailerons

Analysis of the FDR data from G-FLBE showed that the right aileron had previously stopped responding to the position of the handwheels during 14 of the previous 23 flights. Durations varied from between two and thirty-five minutes.

The aileron typically became unresponsive as the aircraft approached the top of climb or was in the cruise. There was, however, one flight where the aileron was unresponsive during descent from FL100 to FL060. The movement of the aileron always returned to normal prior to the aircraft starting the final approach. Normal operation of the aileron often coincided with movement of the handwheel as the aircraft entered a turn.

During the three flights prior to the incident flight, the right aileron was unresponsive for periods of 25, 35 and 26 minutes respectively. For the flights prior to these three, there was more variation in the duration that the right aileron was unresponsive.

The operator's Flight Data Monitoring department subsequently analysed data from its fleet of DHC-8-400 aircraft to identify if the right aileron was unresponsive on other aircraft. Initially 32 flights from 16 aircraft were reviewed and during half of these the right aileron was unresponsive for periods during flight. The review was extended to 51 aircraft for seven days flying during February 2020 and after the aileron cables had been replaced and tensioned on G-FLBE. The review looked for periods when the right aileron remained unresponsive to handwheel movement for more than 60 seconds. The results were:

- Thirty-six out of fifty-one aircraft had unresponsive ailerons.
- Twelve of the aircraft with an unresponsive aileron had an occurrence rate of 25% or more.
- The fleet leader was G-FLBE with a rate of 64% (21 events during 33 flights).

The operator had scheduled work on G-FLBE to isolate the cause of the unresponsive right aileron but ceased trading prior to this being concluded.

Manufacturer's response

The aircraft manufacturer analysed the FDR data from G-FLBE and offered several reasons as to why the ailerons could become unresponsive:

- Frozen hinge bearing,
- Frozen pulley bearing,
- Deteriorated flap seal and/or aileron hinge seal,
- Low cable tension, or
- Damaged wires snagging on pulleys.

Modelling of the FDR data from one of G-FLBE's flights, before the left aileron cable broke, showed that during a period when the right aileron had been unresponsive, the left aileron had continued to operate normally. This modelling was not applied to the entire flight nor to other previous flights recorded on the FDR.

FDR parameter filtering

Filtering of parameters

During this investigation, the aircraft manufacturer informed the AAIB that filtering was applied to the position of the handwheels, control columns and rudder pedals recorded on the FDR fitted to G-FLBE. The filtering was used to smooth out signal noise using a moving average calculation that was not reversible. This meant that during rapid control movements, the actual position of the controls could not be reliably reconstructed from FDR data. The filters also caused the recorded positions of the control inputs to lag the movement of the control surfaces (which were not filtered) by about 0.5-second. The filtering was in place on all of the operator's fleet of DHC-8-400 aircraft, and other aircraft operating in Europe.

The FDR system fitted to the DHC-8-400 aircraft met the minimum performance standard defined by European Organization for Civil Aviation Equipment (EUROCAE) document

ED- 55¹⁷ dated 1990. This provided requirements for the accuracy of FDR parameters but did not address filtering.

Previous Safety Recommendations

The issue of parameter filtering has previously been addressed by the NTSB and AAIB. Details are in the Appendix to this report and a summary is provided below:

In 1994, the NTSB issued two Safety Recommendations to the FAA to require that filtering should not be used unless the position of the flight controls can be recovered from the FDR. In 2000, the Safety Recommendations were closed and classified as '*acceptable action*'.

In 1999, the AAIB issued two Safety Recommendations to the CAA, one of which was to alert EUROCAE¹⁸ of the problem. The Safety Recommendations were accepted and guidance on parameter filtering was issued in 2003. The CAA also advised that changes to the JAR would be sought from the JAA¹⁹, but no changes were made to the JAR.

In 2003, the NTSB made three Safety Recommendations regarding the sampling rate and filtering of the position of control surfaces following the in-flight failure of a fin on an Airbus A300-600. In 2010 the FAA amended Federal Aviation Regulations (FAR) to address parameter filtering.

In 2013, the manufacturer of the DHC-8-400 aircraft advised USA operators that because an irreversible filter had been applied to the handwheel, control column and rudder pedals position and force parameters, the FDR installation on these aircraft did not meet the FAR. A SB was subsequently issued in December 2013 to correct this. This SB was not applicable to aircraft registered outside the USA. Neither the CAA nor the EASA required irreversible filters to be removed from DHC-8-400 aircraft operating in the UK or Europe.

International Civil Aviation Organisation guidance on FDR parameter filtering

The International Civil Aviation Organisation (ICAO) sets the Standards and Recommended Practices (SARPs) for Contracting States including the UK. ICAO Annex 6, Part 1 is applicable to Commercial Air Transport operations by aeroplanes, and ICAO Annex 6, Part 3 is applicable to helicopters. Both SARPs specify aspects such as the construction and operation of FDR systems, but neither address the recording of filtered parameters.

Footnote

¹⁷ ED-55 Minimum Operational Performance Specification for Flight Data Recorder Systems.

¹⁸ EUROCAE is a non-profit organisation that develops specifications for aircraft electronic equipment. The creation and update of these specifications are made by working groups consisting of industry representatives and experts.

¹⁹ The Joint Aviation Requirements (JAR) were a set of common European aviation requirements issued by the Joint Aviation Authorities, of which the CAA was a member.

Analysis

Effect of the aileron cable breaking

The failure (break) of the aileron control cable affected the position of the left aileron, which caused the aircraft to roll to the left. This was corrected by the pilot and AP providing a correcting input which displaced the handwheel from its normal neutral position. The amount of displacement varied at different stages of the flight due to a combination of the aircraft speed and roll control being assisted by the outboard spoiler: the spoiler becomes active below 165 kt.

The manufacturer was aware of three other events where a broken aileron cable was detected in-flight. As part of this investigation the Regulator and Manufacturer reviewed the risk resulting from the failure of an aileron cable and confirmed that such a failure had a Severity Classification of Minor.

Pilots response to the event

The pilots noticed the effect of the cable break shortly after departing Newquay where the wind was close to the aircraft's crosswind limits of 32 kt. They reviewed the QRH but did not consider any of the checklists to be relevant. Therefore, they carried out a threat assessment and mitigated the risk of flying with a reduced handwheel range of movement by diverting to Exeter where the crosswind was not as strong. The aircraft made an uneventful landing.

An aileron cable breaking in level flight would initially cause an uncommanded roll and the most relevant QRH non-normal checklist was '*Roll Control Malfunction*', which has the precondition '*Aircraft rolls with no control wheel [handwheel] input*'. However, the pilots did not recognise the relevance of this checklist, possibly because the AP was engaged and would have automatically countered the uncommanded roll to the left.

Cable failure

The lower left aileron cable failed due to a combination of internal and external wear. Following the failure, the tension in the upper cable would have caused the aileron to deflect upwards inducing a roll to the left. From the FDR data, it was established that the cable failed between the aircraft landing at Newquay and during the subsequent takeoff.

The landing at Newquay, which was close to the limit for classification as a heavy landing, would not have caused a serviceable cable to fail; however, the aileron cable was worn and its load carrying capability would have been reduced. It is, therefore, possible that the cable failed during the landing.

If the failure had occurred during the landing, then the pilot might have noticed that the aileron was at an unusual angle²⁰ during the pre-flight external inspection. However, the inspection was carried out at night, in gusty, showery conditions which might make it more difficult to notice the unusual angle of the aileron.

Footnote

²⁰ The position of the gust locks would not affect the movement of the aileron following the failure of the cable.

The failure of the aileron cable would have had no significant effect on the force required to operate the handwheels, and the aileron position is not displayed in the cockpit. Consequently, the pilots could not have detected the failure if it had occurred after the external inspection had been completed.

Cable wear and possible causes

The aileron and spoiler cables are known to be susceptible to wear in the areas where they are redirected by pulleys to accommodate the change in the wing dihedral. The manufacturer published their first advice to operators in 2004 and modified cables with a polymer coating were introduced in 2015. The modification was not mandatory and while the operator was in the process of modifying their fleet, the new cables had not been fitted to G-FLBE.

The manufacturer identified low tension, vibration and contamination as the main causal factors for wear in control cables.

Cable tension. The aileron cable was found to be below the minimum allowable tension when it was last checked 1,100 hours before the failure occurred. The cable was re-tensioned, and the aircraft released to service.

If the cable tension is too low, then the friction between the pulley and cable may not be sufficient to overcome the breakout force of the bearing fitted to the pulley with the result that the pulley does not rotate as the cable moves. The resulting sliding contact can cause wear in both the cable and pulley.

Following the cable failure, the pulley on G-FLBE was found to rotate freely. The wear around the pulley's circumference was relatively even and there was no evidence of slippage having occurred. Therefore, low cable tension resulting in slippage between the pulley and cable was not considered to have been a causal factor in the failure of the cable. However, the low tension identified 1,100 hours previously might have been an indication of broken wires inside the cable.

Vibration. The aileron and spoiler cables are routed along the wing rear spar just outboard of the engines. Vibration from the engines could cause increased cable wear if the tension is low, by allowing the individual strands, and wires, to move against each other. The wear resulting from vibration would accumulate at a greater rate in cables that are contaminated with debris. However, the investigation could not establish if vibration from the engines was a causal factor.

The FAA has stated that polymer coated cables should be more tolerant of wear resulting from vibration.

Contamination. The area of the rear wing spars where the aileron and spoiler cables run were found to be heavily contaminated on G-FLBE when it was examined after the failure. The failed cable, and two other cables that were

removed from the operator's aircraft as part of this investigation, were examined and exhibited evidence of wear with excessive amounts of grime, grease and debris both on the cable and imbedded between the strands and wires.

It is known that accumulation of grease and debris on a control cable can cause accelerated wear and it is probable that this was a factor in the aileron cable failing on G-FLBE.

Inspection frequency

Pre-modification cables are required to be wiped clean and visually inspected every 2,500 hours. However, the aileron cable on G-FLBE failed 1,400 hours after its last inspection; the operator also identified 18 cables on their other aircraft, which were not due to be examined, with damage that exceeded the allowable limits. This suggests that the inspection frequency may be inadequate for aircraft whose operations result in a heavy accumulation of dirt along the rear wing spars.

The evidence is that the polymer sleeves fitted to the modified aileron cables reduce the rate of in-service wear as they prevent the ingress of debris into the cable.

Inspection procedure

The effectiveness of the visual inspection relies on the maintainer identifying broken wires, or wear, and assessing the damage against the acceptable limits in the AMM. However, the cable construction means that only 42 of the 133 individual wires are visible and of these 42 wires, only one side of each wire is visible.

While visual inspections are used successfully across the industry as a method of detecting damage in cables, it has an inherent limitation in that it cannot identify internal damage. The probability of identifying broken internal wires can be increased by releasing the cable tension and manipulating the cable, but this is not a requirement of the AMM. The inspection procedure suggests the use of a torch and mirror, where appropriate, and required the handwheel to be moved '*if necessary*' to expose areas of the cable that were normally hidden from view. However, it is not possible to inspect the susceptible sections of the aileron cable without repositioning it by moving the handwheel through its full range of movement.

In order to increase the probability of detecting damage and preventing the failure of control cables that run along the wing rear spar, the manufacturer advised that they had initiated the following safety actions, which should be completed by the end of 2020:

Safety Action

The aircraft manufacturer reviewed the periodic cable inspection procedure and advised that they would amend the procedure to increase the likelihood of identifying cable damage. They also stated that they would issue an All Operators Message to highlight this serious incident and the changes to the inspection procedure.

Unresponsive aileron movement in-flight

The investigation found that the right aileron recorded on the FDR on the operator's DHC-8-400 aircraft would routinely stop responding to handwheel movements during flight. Most events occurred when the aircraft was near the top of climb or in the cruise, and the movement would return before the aircraft landed. The spoilers continued to operate normally throughout the flights.

The aircraft manufacturer modelled the FDR data from one of G-FLBE's flights before the cable had broken. This indicated that during the period when the right aileron had been unresponsive, the left aileron had continued to operate normally. This modelling was not applied to any other flights.

The left and right aileron system share a common design; therefore, the left aileron could equally be susceptible to becoming unresponsive. The aircraft manufacturer advised that on G-FLBE there could be several reasons for the aileron becoming unresponsive including frozen hinge bearing; frozen pulley bearing; deteriorated flap seal and/or aileron hinge seal; low cable tension or damaged wires snagging on pulleys. FDR data showed that during flight the unresponsive right aileron would suddenly return to normal operation. This typically occurred when a left or right turn was initiated.

The low cable tension would have resulted in a more gradual movement of the aileron, rather than a sudden movement as it returned to normal. Moreover, after the cables were replaced and correctly tensioned on G-FLBE the problem remained. Therefore, the right aileron becoming unresponsive was likely to have been caused by a restriction, or a combination of restrictions. There was no evidence of the AP disconnecting during periods when the right aileron was unresponsive or when it returned to normal; therefore, the force to overcome the restriction/s did not exceed 17.5 lb at the handwheel.

The operator was in the process of investigating the cause of the unresponsive aileron on G-FLBE when they ceased trading. Consequently, the cause was not identified.

In order to understand if other operators of DHC-8-400 aircraft had also experienced unresponsive ailerons, the manufacturer advised that they had initiated the following safety action:

Safety Action

The aircraft manufacturer advised that it would provide literature to operators to monitor for unresponsive ailerons using their Flight Data Monitoring Programmes.

Although the aircraft manufacturer has initiated safety action to monitor for unresponsive ailerons, the specific causes and rectification actions have yet to be determined. It is important that accident investigators and operators fully understand why the aileron becomes unresponsive, its effect on aircraft performance and what rectification action is required. Therefore, the following Safety Recommendation is made:

Safety Recommendation 2020-024:

It is recommended that Transport Canada require De Havilland Canada to determine why the aileron control surfaces on the DHC-8-400 series of aircraft can become unresponsive to handwheel movements and ensure that the findings and any rectification action is promulgated to operators.

FDR parameter filtering

On the DHC-8-400 aircraft operating in Europe, irreversible filters are applied to the data from sensors on the handwheels, control columns and rudder pedal positions and forces recorded by the FDR. Consequently, the actual sensor position of these parameters may not be reliably reconstructed during rapid movements of the controls. In 2014, the FAA required irreversible filters to be removed from the DHC-8-400 aircraft registered in the USA; however, no similar requirement was made for DHC-8-400 aircraft registered in Europe²¹.

It is essential during safety investigations to have access to FDR data which can be used to reconstruct an accurate and unambiguous time history of each parameter's activity, which the use of irreversible filters precludes. Therefore, the following Safety Recommendation is made to the EASA:

Safety Recommendation 2020-025:

It is recommended that the European Union Aviation Safety Agency require that the flight data recorder system fitted to DHC-8-400 series of aircraft registered in Europe record unfiltered data for the parameters representing primary flight control input positions and input forces, so that their original sensor signal values can be reliably established.

To ensure National Aviation Authorities adopt a common international standard on the use of filters applied to the parameters recorded by the FDR, the following Safety Recommendation is made to the ICAO:

Safety Recommendation 2020-026:

It is recommended that the International Civil Aviation Organisation provide guidance on the recording of filtered parameters by the flight data recorder system. The guidance should address as a minimum:

1. Definitions for filtered and unfiltered parameters.
2. Parameters on the FDR for which filtering is not permitted.
3. The need to be able to reconstruct the original sensor signal values from filtered data recorded during extremely dynamic conditions and that the information to achieve this is a permanent part of the aircraft specific FDR system documentation package.

Footnote

²¹ Parameter filtering for DHC-8-400 aircraft registered in the USA was removed by SB 84-31-65 that fitted a modified Flight Data Signal Conditioning Unit (FSCU). This FSCU would also remove parameter filtering from DHC-8-400 aircraft registered in Europe.

Conclusion

The most probable reason for the aileron cable breaking was that its strength had reduced as a result of wear leading to the failure of individual wires within the cable. The cable failed where it passed over a pulley on the rear wing spar where dirt accumulates which can penetrate into the strands and form an abrasive compound. This can accelerate the normal rate of cable wear. Post-modification cables are available which have a sleeve fitted over the susceptible section to prevent the ingress of dirt. The investigation established that the inspection procedure in the AMM would not have detected the damage to individual wires that run inside the cable.

The unresponsive right aileron on G-FLBE was not causal to this serious incident. As the operator ceased trading before they could establish the cause on G-FLBE, and other aircraft in their fleet, further investigation is required to determine if there is a wider safety issue.

Filters applied to some of the flight control parameters recorded on the FDR can affect the reconstruction of the rapid movement of the controls. Such filters are not permitted to be installed on the DHC-8-400 aircraft registered in the USA, but there is no similar requirement on aircraft registered in Europe or the UK. While this did not affect this investigation, this could affect other safety investigations.

Safety actions/Recommendations

Safety Recommendations

The following Safety Recommendations were made:

Safety Recommendation 2020-024:

It is recommended that Transport Canada require De Havilland Canada to determine why the aileron control surfaces on the DHC-8-400 series of aircraft can become unresponsive to handwheel movements and ensure that the findings and any rectification action is promulgated to operators.

Safety Recommendation 2020-025:

It is recommended that the European Union Aviation Safety Agency require that the flight data recorder system fitted to DHC-8-400 series of aircraft registered in the United Kingdom record unfiltered data for the parameters representing primary flight control input positions and input forces, so that their original sensor signal values can be reliably established.

Safety Recommendation 2020-026:

It is recommended that the International Civil Aviation Organisation provide guidance on the recording of filtered parameters by the flight data recorder system. The guidance should address as a minimum:

1. Definitions for filtered and unfiltered parameters.
2. Parameters on the FDR for which filtering is not permitted.
3. The need to be able to reconstruct the original sensor signal values from filtered data recorded during extremely dynamic conditions and that the information to achieve this is a permanent part of the aircraft specific FDR system documentation package.

Appendix

In 1994 the NTSB made Safety Recommendation A-94-120 and A-94-121 to the FAA to address parameter filtering. This followed an NTSB investigation where it had been demonstrated that it was not possible to determine the actual position of filtered control surfaces recorded by the FDR system fitted to Boeing 757 and 767 aircraft:

***‘NTSB Recommendation A-94-120** The NTSB recommends that the federal aviation administration: require design modification to the Boeing 757/767 so that flight control position data to the DFDR is accurate and not filtered by the EICAS. The sample rate should also be increased to an appropriate value’.*

***‘NTSB Recommendation A-94-121** The NTSB recommends that the federal aviation administration: review other airplane designs to ensure that flight control position data to the DFDR are accurately recorded and that flight control position data filtered by systems such as EICAS are not substituted for accurate data’.*

The FAA subsequently required that the filtering was to be removed from Boeing 757 and 767 aircraft by May 2000. The FAA also reviewed other aeroplane designs²² and in 1999 it published Advisory Circular (AC)²³ 20-141²⁴. This provided guidance on FDR parameter filtering and recommended that no significant²⁵ differences should exist between the actual control surface position and the signal recorded on the FDR during both static and dynamic conditions²⁶. The FAA also stated that it would ensure that USA operators would no longer record filtered parameters on the FDR.

In 2000, the NTSB classified Recommendation A-94-120 and A-94-121 as ‘closed – acceptable action’ in lieu of assurances from the FAA that filtered FDR data would be precluded.

Footnote

²² Aerospatiale, CASA, Cessna, Grumman, Gulfstream, Israel Aircraft Industries, Lockheed, and SAAB.

²³ An AC is not mandatory or a regulation, but can provide information on an acceptable means of compliance when applying for certification.

²⁴ AC 20-141 was superseded by AC 20-141B in 2010. This contained additional guidance information on parameter filtering.

²⁵ The FAA defined no significant difference as ‘any differences between the data recorded under static conditions and the data recorded under dynamic conditions should be less than the correlation coefficient derived using static parameter values.

²⁶ Defined by the FAA as when undergoing change at the maximum rate expected when operating the aircraft in accordance with the flight manual.

In 1999, the AAIB investigated a landing accident involving a Boeing 767 aircraft, registration N373AA. The filtering of the flight control parameters was still in place on this aircraft. The AAIB subsequently made the following Safety Recommendations to the CAA to address the use of parameter filtering for aircraft registered in the UK and Europe, and to amend international specifications applicable to FDR systems:

AAIB Recommendation 99-43²⁷

The Civil Aviation Authority initiate action to change Joint Aviation requirements in JAR OPS 1.715 (d), 1.720 (d) and 1.725 (d), which currently read:

"Data must be obtained from aircraft sources which enable accurate correlation with information displayed to the flight crew"

and which should be rewritten to read:

"Ensure that accurate data is recorded on the DFDR and that data filtered by systems for displays to the flight crew is not substituted for accurate data"

Note: Changes to 1.720 and 1.725 are required to cater for the situation where modern, novel and/or unique avionics are fitted into old airframes. The revised paragraph should be added to 1.715 to cater for DFDR designs in new aircraft.

AAIB Recommendation 99-44

The Civil Aviation Authority alert EUROCAE WG50 to the problems posed by filtered data so as to ensure that the latest revision of ED55 contains suitable advice on the need to avoid substituting filtered data for accurate data in recording systems.

Safety Recommendations 99-43 and 99-44 were accepted by the CAA in 2000, and specification ED-55 was subsequently superseded by ED-112²⁸ in 2003. This incorporated the following guidance on parameter filtering; the same information was included in ED-112A which superseded ED-112 in 2013:

Parameter filtering ED112 and ED-112A - section II-A.9

'Data shall be obtained from sources within the aircraft, which provide the most accurate and reliable information under both static and dynamic conditions. The use of filtered data should be avoided but may be used if it can be demonstrated that the accuracy requirements are maintained for values recorded during dynamic conditions equivalent to the operational limits of the system being measured.' The actual sensor value shall be retrievable from the filtered data

Footnote

²⁷ JAR OPS 1.715 was applicable to aeroplane's first issued with an individual certificate of airworthiness (C of A) on or after 1 April 1998, JAR OPS 1.720 was applicable to aeroplane's first issued with an individual C of A on or after 1 June 1990 up to and including 31 March 1998 which had a maximum certificated takeoff mass over 5 700 kg. JAR OPS 1.725 was applicable to any turbine engine aeroplane first issued with an individual C of A, before 1 June 1990 which has a maximum certificated takeoff mass over 5,700 kg.

²⁸ Minimum Operational Performance Specification for Crash-Protected Airborne Recording Systems

by any technically cognizant individual in an 8 hours period using existing, and easily understood instructions that specify commonly available tools and techniques.'

ED-112 and ED-112A also stated that filtering shall be avoided for parameters representing primary flight control positions and forces, position of the power levers and positions of primary flight surfaces, unless it can be demonstrated that:

'The recorded values meet the accuracy requirements in extremely dynamic conditions, in spite of the filtering; or, original sensor signal values can be reconstructed from filtered data recorded in extremely dynamic conditions, and this reconstructed values meet the accuracy requirements (see tables II-A.1 and II-A.2). The original sensor values shall be retrievable by applying a unique algorithm to the filtered values. This algorithm shall be a permanent part of the aircraft specific FDR system documentation package.'

The CAA response to AAIB Recommendation 99-43 stated *'Action to initiate changes to the requirements in JAR OPS 1.715 (d), 1.720 (d) and 1.725 (d) in line with those set out in this Recommendation has already been taken with the Joint Aviation Authorities (JAA) Flight Recorder Study Group.'* However; no changes were subsequently made to JAR OPS 1.715 (d), 1.720 (d) or 1.725 (d). It is not known why the changes were not made.

The JAA JAR-OPS 1 requirements for commercial air transport aeroplanes were replaced by EU-OPS in 2008: this was subsequently superseded in 2012 by Commission Regulation (EU) No 965/2012 EASA Air Ops regulations. This required that the actual position of filtered parameters should be recoverable (as defined in ED-112A) for fixed-wing aircraft²⁹ and helicopters fitted with an FDR, and first issued with an individual C of A after 01 January 2016. However, this requirement was not applicable to fixed-wing aircraft or helicopters first issued with a C of A before 1 January 2016; this included G-FLBE and the operator's fleet of DHC-8-400 aircraft.

In November 2003, the NTSB notified the FAA that its investigation³⁰ into the in-flight separation of the vertical fin and rudder of an Airbus A300-600 had been hampered by the low sampling rate and filtering of the rudder control surface recorded by the FDR. The NTSB subsequently made three Safety Recommendations (A-03-48, A-03-49 and A-0-50) to the FAA. These addressed accuracy, sampling rate and filtering of parameters, so that an unambiguous time history of parameter activity could be obtained from the FDR.

In 2010, the FAA responded to the recommendations by adding new rules to 14 CFR³¹ Part 121, 125 and 135³² as FARs 121.346, 125.228 and 135.156. This required manufacturers

Footnote

²⁹ EASA define aeroplane as a fixed wing aircraft. This report uses the term aircraft instead of aeroplane.

³⁰ <https://www.ntsb.gov/investigations/AccidentReports/Reports/AAR0404.pdf> [Accessed 1 October 2020].

³¹ Title 14 of the Code of Federal Regulations.

³² Part 121 - operating requirements: domestic, flag, and supplemental operations,
Part 125 - certification and operations: airplanes having a seating capacity of 20 or more passengers or a maximum payload capacity of 6,000 pounds or more,
Part 135 - operating requirements: commuter and on demand operations.

to either provide information that enabled the actual sensor positions to be accurately reconstructed from filtered parameters on the FDR, or the filters were to be removed. This was to be completed by 1 April 2014, and was applicable to the following FDR parameters:

- Pitch control, lateral control and rudder control inputs.
- Primary pitch, lateral and yaw control surface positions.
- Throttle/power lever positions.
- All flight control input forces (handwheel, column and rudder pedals).

In September 2013 the manufacturer of the DHC-8-400 advised USA operators³³ that the FDR system did not meet the requirements of FAR 121.346. This was because an irreversible filter was applied to the handwheel, control column and rudder pedal positions and forces³⁴. The FDR system fitted to DHC-8-100, -200 and -300 aircraft was not affected. In December 2013 the aircraft manufacturer issued SB 84-31-65. This fitted a Flight Data Signal Conditioning Unit (FSCU)³⁵ that removed the filtering. SB 84-31-65 was not applicable to DHC-8-400 aircraft registered outside the USA.

Published: 15 October 2020.

Footnote

³³ Service Letter (SL) DH8-400-SL-31-007B refers.

³⁴ The input force parameters are only required to be recorded for aircraft registered in Europe that were first issued with a C of A on or after 1 January 2016 and in the USA for all turbine-engine-powered transport category airplanes manufactured after 19 August 2002.

³⁵ Honeywell Avionics manufactured FSCU, part number 1152862-5.