

**SERIOUS INCIDENT**

<b>Aircraft Type and Registration:</b>	Britten-Norman BN-2B-21 Islander, VP-AEJ	
<b>No &amp; Type of Engines:</b>	2 Lycoming IO-540 piston engines	
<b>Year of Manufacture:</b>	1980	
<b>Date &amp; Time (UTC):</b>	4 July 2018 at 1940 hrs	
<b>Location:</b>	On approach to Robert L. Bradshaw Airport, Saint Kitts	
<b>Type of Flight:</b>	Commercial Air Transport (Passenger)	
<b>Persons on Board:</b>	Crew - 1	Passengers - 4
<b>Injuries:</b>	Crew - None	Passengers - None
<b>Nature of Damage:</b>	Broken aileron drive rod	
<b>Commander's Licence:</b>	FAA Commercial Pilot's License	
<b>Commander's Age:</b>	30 years	
<b>Commander's Flying Experience:</b>	875 hours (of which 700 were on type) Last 90 days - 95 hours Last 28 days - 33 hours	
<b>Information Source:</b>	Aircraft Accident Report Form submitted by the pilot	

**Synopsis**

During a short flight between the islands of Saint Eustatius and Saint Kitts, Caribbean, the pilot noticed that the ailerons felt "sluggish" but the aircraft landed successfully at Saint Kitts. It was found that a drive rod for the right aileron had broken and a spherical bearing, fitted to one end of the rod, had corroded heavily and was seized. Several safety actions have been taken to reduce the maintenance interval for control rods due to an increased risk of corrosion from the environmental factors where the aircraft operated. This investigation was delegated by the Dutch Safety Board to the AAIB in accordance with paragraph 5.1 of ICAO Annex 13.

**History of the flight**

The aircraft took off from Runway 06 at F. D. Roosevelt Airport on the island of Saint Eustatius, Caribbean, at 1930 hrs and routed to Robert L. Bradshaw International Airport on the island of Saint Kitts. Once airborne, the pilot noticed the ailerons felt "sluggish" on a right turn. The flight time between the islands was estimated to be 10 to 12 minutes, so the pilot continued the flight and landed at Saint Kitts at 1942 hrs. Despite reduced aileron control on the final approach, the pilot landed safely and the passengers disembarked normally. The pilot then carried out a walk-around inspection of the aircraft and found the right aileron drive rod had broken, so he informed the maintenance organisation.

## Aircraft examination

On the evening after the incident flight, the maintenance organisation attended the aircraft and replaced the broken aileron drive rod in the right wing (Figure 1).

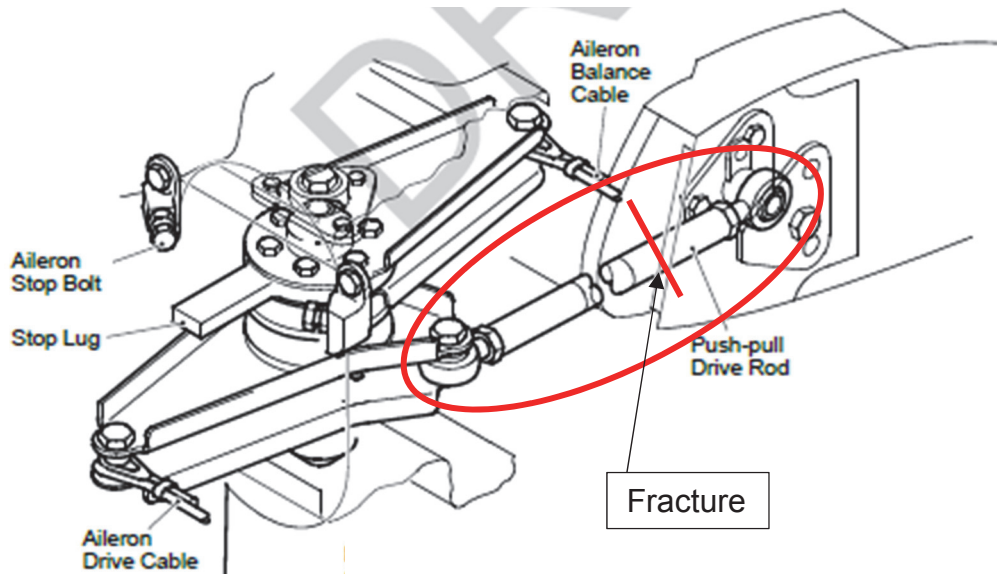

**Figure 1**

Aileron drive mechanism

An examination of the drive rod found that the spherical bearing in the rod end that connected to the aileron was heavily corroded and had seized. The rod had suffered an overload fracture 70 mm from the rod end at an area where the rod end had been riveted (Figure 2).



**Figure 2**

Broken drive rod

## Analysis

It is the assessment of the aircraft manufacturer that the cause of the failure of the drive rod was initiated by the bearing corroding, which resulted in the seizure of the bearing. When normal operation loads were applied to the aileron drive mechanism they were sufficient to overload the rod and cause it to fracture. The aircraft manufacturer has published Service letter SL 127 '*Greasing of Aileron Rod End Bearings*' to remind operators of the greasing requirements and to request relevant feedback on bearing corrosion.

The maintenance organisation stated that much of the Caribbean coastline had recently been inundated with large quantities of Sargassum seaweed and as it decomposes, it releases hydrogen sulphide into the atmosphere. There had been several large storms and hurricanes pass through the region recently and this, coupled with the increased levels of hydrogen sulphide, may have resulted in accelerated corrosion in some components. The maintenance programme for the aircraft states a lubrication interval of 1,000 hours but the maintenance organisation is amending their programme to reduce this interval to 100 hours to prevent reoccurrence. Further, they have initiated a fleet-wide inspection programme of all aircraft drive rods and bearings to identify corroded bearings.

## Conclusion

An aileron drive rod bearing had corroded and seized which resulted in the drive rod becoming overloaded and failing under normal operational loads. It is possible that the operating environment was more corrosive than the aircraft manufacturer expected when defining the lubrication tasks in the aircraft maintenance programme.

## Safety actions

The following safety actions have been taken:

### **Aircraft manufacturer**

Service Letter SL127 published to remind operators of the greasing requirements and to provide relevant feedback.

### **Maintenance organisation**

A reduction in the lubrication task interval from 1,000 hours to 100 hours for the aileron drive rod bearings.

A fleet-wide corrosion inspection of all drive rod/bearing assemblies.