

PART 8

MACHINERY INSTALLATIONS

PART 8

MACHINERY INSTALLATIONS

SECTION	SUBJECT
8.1	General
8.2	Auxiliary engines
8.3	Stern gear
8.4	Propeller and nozzles
8.5	Rudders
8.6	Steering gear
8.7	Tables
8.7.1	Rudders and steering
8.8	Figures and illustrations
8.8.1	Dry exhaust system

MACHINERY INSTALLATIONS

Section 8.1 - General

- 8.1.1 Propulsion machinery is to be of a type and power suitable for the method of fishing, and for the design and dimensions of the vessel. The machinery is to be installed in accordance with the best current marine engineering practice, these Standards, and to the engine Manufacturer's requirements. In all cases, engine power is to be to the Manufacturer's continuous rating to ISO/DIN Standards. Where engines are de-rated, ventilation inlet areas, shaft line scantlings, etc. are to be determined without the effect of de-rating being taken into consideration. Every vessel should have adequate power for astern manoeuvring and to maintain proper control in all foreseeable service conditions.
- 8.1.2 Propulsion and auxiliary machinery installed below deck/sole is to be suitable for use with diesel fuel, and is to be of an accepted marine type or, where based on an industrial engine, be marinised to the Manufacturer's approved Standards. Emission controls are to comply with current statutory requirements.
- 8.1.3 Where the engine is installed on flexible mountings, a flexible coupling is to be fitted between the engine/gearbox and the propeller shafting. The exhaust, water and oil pipes, should have a short length of approved fire-resistant flexible piping fitted for connection to the engine. Auxiliary engines are to be installed to the same standard as the propulsion machinery. Earth bonding cables are to be fitted in way of flexible couplings and hose connections on piping.
- 8.1.4 Where power take-offs are fitted to the main engine for auxiliary drives, the power to be taken off should not exceed the engine Manufacturer's permitted limits, and a flexible coupling is to be fitted between the engine and the forward drive, except where it is integral with the engine. Power take-off drives fitted to flexibly mounted engines should also be flexibly mounted, and on seatings integral with the engine. Where clutches are fitted to drives, they are to be of adequate capacity for the purpose intended.
- 8.1.5 It is recommended that all single handed operated vessels are fitted with an emergency kill system for the main engine, in case of a man overboard situation.
- 8.1.6 Where a lay-shaft is driven by a pulley and belt, the driven shaft is to be fitted with bearings on each side of the pulley. Drives to side layshafts are to comply with the engine Manufacturer's requirements for permissible side loads.

- 8.1.7 Auxiliary pumps driven by the main engine and not continuously running, are to be fitted with a clutch with local or remote control.
- 8.1.8 Belt drives are to be arranged with a method of adjusting the belt tension, and special attention is to be given to providing separate tensioning for each driven item. Belt and chain drives, exposed shafting, clutches, moving parts, etc., are to be fitted with suitable guards to the satisfaction of the Surveyor.
- 8.1.9 Metal exhausts serving the engine(s) are to be lagged with an approved material, fitted with the minimum number of bends, and are to be of a diameter as required by the engine Manufacturer. All exhaust piping joints are to be gas tight, and the pipe supported by hangers or brackets designed to allow for expansion and contraction of the exhaust pipe. The connection to the engine should be with a metal bellow piece. Care is to be taken to provide an efficient barrier to prevent damage from the hot exhaust. Exhausts are to be adequately ventilated and guards are to be fitted over hot surfaces. See Figure 8.9.1.
- 8.1.10 Where a water injected exhaust system is fitted and is discharging at side or transom below the weather deck, sea water from the engine cooling system is to be introduced into the exhaust pipe near to the manifold. A 'U' bend or water trap should be incorporated in the exhaust system to avoid flow back of water into the engine. An approved type of flexible heat/acid resistant rubber exhaust hose may be fitted. The requirements of Part 3, Section 3.7 are to be incorporated.
- 8.1.11 Vessels with a total main engine power exceeding 200kW should carry the following equipment and instruments as a minimum:-
- Engine revolution counter
 - Engine lubricating oil pressure gauge
 - Engine water temperature gauge
 - Gearbox oil pressure gauge (where applicable)
 - Ammeter or battery charge indicator (for service batteries)
 - Ahead/astern control
 - Engine stop
 - Engine start (if electric start)
 - Audible and visual alarm for high water temperature
 - Audible and visual alarm for low lubricating oil pressure
 - Visual alarm or battery charge indicator for starting batteries, (if separate from service batteries).

- 8.1.12 In vessels with main engine power below 200kW, the following minimum requirements are to apply:-
- Engine revolution counter
 - Engine stop
 - Lubricating oil pressure gauge and alarm
 - Engine water temperature gauge and alarm
 - Battery charge warning light.
- 8.1.13 The instruments/gauges are to be marked to indicate abnormal conditions and fitted with adjustable illumination.
- 8.1.14 In all installations, electric starting, charging, and alarm systems, are to comply with the requirements of Part 10 of these Standards.
- 8.1.15 In open boats, where the propulsion engine is housed within an enclosed box, the controls and instruments are to be mounted in a protected area, at, or visible from, the steering or control position.
- 8.1.16 Proposals for unorthodox machinery installations and propulsion transmissions are to be submitted for consideration.
- 8.1.17 In vessels 10m LOA and over with an enclosed machinery space, at least two means of escape from the engine room should be provided, separated as far apart as practicable, except that, where the size of the machinery space renders this impracticable, one escape may be fitted, subject to approval.
- 8.1.18 The machinery space is to be designed to give safe and free access to all parts of the engine(s) for normal servicing and maintenance. All parts are to have adequate lighting. Ladders are to be of steel and adequately secured.
- 8.1.19 The machinery space is to be adequately ventilated to meet engine Manufacturer's requirements for the engine maximum continuous rating. Where air supply fans are fitted, the fan controls are to be located outside the machinery space.
- 8.1.20 In case of fire and to prevent the excessive ingress of water, all ventilators are to be fitted with a method of closure to the acceptance of the Surveyor, operable from outside the machinery space. A permanent notice is to be fitted on the hatch lid or in a visible location in close proximity stating **"TO BE CLOSED IN THE EVENT OF FIRE"**.
- 8.1.21 All floor plates and floor areas are to be of non-slip material or finish. Floor plates are to be securely fastened in position.
- 8.1.22 Where outboard engines are fitted, it is recommended the transom is to be fitted with a securely attached plate on both sides as reinforcement for the engine fastening bolts. Outboard motor wells are to be adequately drained,

and the well should be of such size that the motor can be easily manoeuvred and tilted. Holes carrying control cables, fuel pipes, etc. through the transom are to be located as high as practicable to prevent water ingress, and protected against chafe. This may be by means of a gaiter/gland fitting, or other approved method.

- 8.1.23 All propulsion engines are to be fitted with a secondary means of starting.
- 8.1.24 Where sea water is used for the cooling of inboard mounted engines, an efficient strainer is to be fitted between the sea inlet valve and the pump. The strainer is to be accessible and capable of being cleared from inside the vessel. Vessels of 10m LOA and over should be fitted with a permanent alternative means for providing sea water cooling to the propulsion engine, which can be operable without tools in the event of failure or blockage of the main inlet.
- 8.1.25 Seawater strainer located within the machinery space are to be of metal construction or fire rated to a recognised Standard. Glass topped strainers are not to be used.

Section 8.2 - Auxiliary engines

- 8.2.1 In any vessel where an auxiliary engine is provided, it is to be installed to best marine practice and to the approval of the Surveyor.
- 8.2.2 A separate fuel supply with approved filters is to be provided for each engine.
- 8.2.3 Each such engine is to have a separate exhaust system which should be installed as for the main engine.
- 8.2.4 Where the auxiliary engine is flexibly mounted, exhaust, fuel, and water pipes should have a length of approved flexible fire-resistant piping fitted for connection to the engine.
- 8.2.5 Equipment which is belt driven from the auxiliary engine is to have suitable devices fitted to enable belt tension adjustment for each individual item of driven equipment.
- 8.2.6 Exposed moving parts and drives are to be fitted with guards to the approval of the Surveyor.

Section 8.3 - Stern gear

- 8.3.1 Propeller shaft and intermediate shafts are to be that recommended by the stern gear and engine Manufacturer.

8.3.2 Stern tube is to be carefully aligned. Stern tube and shaft bracket bearings are to be of an approved type, and are to be of the shaft and engine Suppliers' requirements.

8.3.3 The distance between the shaft bearings must not be greater than that specified in the following formula:-

$$S = 0.142 \times \sqrt[3]{d^2}$$

where 'S' = distance between bearing centres in metres
'd' = diameter of shaft in millimetres.

8.3.4 Where a shaft penetrates a watertight bulkhead, the watertight integrity and strength of the bulkhead is to be maintained.

8.3.5 The propeller is to be designed to permit the engine to run at its continuous rating without overload, and with tip clearance to Manufacturer's requirements.

8.3.6 Suitable arrangements are to be provided for safe access to the stern gland and bearings. Adequate provision is to be made for renewal of stern gland packing (where applicable).

8.3.7 Header tanks for oil-filled stern tubes are to be located in an accessible position, and be complete with level indication or contents gauge.

Section 8.4 - Propeller and nozzles

8.4.1 The connection of propulsion nozzle/propeller and alignment is to be as directed by Manufacturer's guidelines, with the propeller fitted to ensure correct tip clearances prior to final welding. Substantial headbox connected to shell plate with adequate internal stiffening to ensure continuity of strength. See Section 4.7.

Section 8.5 - Rudders

8.5.1 Rudders may be of steel, stainless steel, aluminium, GRP or timber construction, and of a design strength and area compatible with the size and power of the vessel.

8.5.2 Rudders of metal may be either single or, double plate type. Blade thickness is to be as determined in accordance with Table 8.8.1. Double plate rudders are to be constructed watertight and fitted with a drain plug. Such rudders may be filled with an approved internal coating or filling. The side plating of double plate rudders are each to be a minimum of 6mm.

8.5.3 Double plate rudders of welded steel or aluminium construction in excess of 600mm deep, are to be fitted with an internal web plate welded to the stock, and welded to each side plate by means of slot or plug welds. The thickness of the web plate is to be that required for single plate rudders.

- 8.5.4 Steel rudder stocks are to be in accordance with Table 8.8.1 and are to be fitted with welded and keyed or spigoted coupling flanges. The stock is to be continuous from the coupling to the lower pintle.
- 8.5.5 Table 8.8.1 is for balanced and semi-balanced rudders supported with a lower (pintle) bearing in the skeg or stern frame extension, and with an upper bearing fitted at the hull position.
- 8.5.6 The upper or hull bearing is to be fitted with an accessible and adjustable watertight gland, fitted above the waterline where practicable.
- 8.5.7 Rudder bearings are to be fitted with a sleeve and bush of compatible materials, and bearings are to be securely locked in place. Means are to be provided for removal of bearings.
- 8.5.8 Where the weight of the rudder is supported at the top by a carrier, the seating for the carrier bearing is to be stiffened locally to the approval of the Surveyor.
- 8.5.9 Rudders of timber construction are to be attached to the stock by welded forks of a thickness equal to the thickness of steel blades, and with bolt fastenings equal to the diameter of the coupling bolts. Thickness of blade is to be in accordance with Table 8.8.1.
- 8.5.10 Single blade rudders of GRP construction are to have steel reinforcing bars welded to the stock.
- 8.5.11 Rudder coupling bolts are to be of the fitted type, and are to be provided with locking arrangements. For dimensions of coupling flanges and bolts see Table 8.8.1.
- 8.5.12 Where the arrangement of the rudder and stock allows an excessive vertical movement, a removable jumping collar is to be fitted above the rudder coupling flange to prevent the stock lifting out of the pintle bearing, and to avoid contact with the shell by the upper edge of the rudder or coupling.
- 8.5.13 Proposals for active/semi-active rudders are to be submitted for consideration.

Section 8.6 - Steering gear

- 8.6.1 The steering gear is to be suitable for the size and power of the vessel.
- 8.6.2 Where a power operated system is used, the system is to incorporate arrangements for hand operation in the event of power failure.
- 8.6.3 In all vessels where the steering is remotely controlled from a helm or control position, an emergency steering system is to be provided which is capable of operation at navigable speeds. The emergency steering may

consist of a drop-on tiller arm to the top of the rudder stock via a deckplate in the deck over the rudder stock, but may be operated from below deck providing efficient communication can be maintained between the emergency steering position and the helm or control position. Where it can be demonstrated that a twin propulsion system will provide an adequate secondary means of steering then this may be accepted as the emergency steering system. Twin installations are to be fitted with a bypass valve to enable the rudder blades or outboard motors to be centralised in an emergency.

- 8.6.4 Single line hydraulic systems (flow and return) are to be provided with an accessible bypass valve between the flow and return pipes in order that pressure can be relieved when operating emergency gear.
- 8.6.5 Mechanical parts of steering systems are to be installed such that they are accessible for lubrication and maintenance. All moving parts are to be protected against contact with loosely stowed items such as fishing gear, etc.
- 8.6.6 All remotely operated steering gears are to be provided with rudder stops at the limiting angle of the steering gear each side. Alternative arrangements are to be submitted for approval prior to installation.
- 8.6.7 Steering gear for vessels of greater numeral than 300 is to be hand hydraulic or power assisted.
- 8.6.8 Where steering is proposed by other means (e.g. steerable nozzle, multiple rudders, etc.) details are to be submitted for consideration.

8.7 Tables

8.7.1 Table 1: Rudders and steering

Scantling numeral	Stock	Blade thickness	
	Steel diameter mm	Steel mm	Wood mm
10	30	6	25
15	30	8	40
20	30	8	45
25	40	8	50
30	40	8	60
45	40	10	65
60	45	10	65
80	45	10	70
100	45	10	75
150	50	10	85
200	65	12	90
250	70	12	100
300	75	12	100
400	85	12	100
500	90	12	110

Table below is for mild steel plate and bar.

Where stainless steel is to be used the grade is to be 316L or a higher grade.

Notes:-

1. The diameter of rudder coupling bolts must not be less than $d = 0.65 \times \frac{ds}{\sqrt{n}}$
where 'd' = bolt dia.; 'ds' = dia. of stock; 'n' = no. of bolts (minimum of 4).
2. The pitch circle diameter of rudder coupling bolts is to be a minimum of 2 times diameter of stock.
3. The coupling flange thickness is to be not less than 0.25 times upper stock diameter.
4. Where higher tensile steels are proposed for rudder stocks of reduced diameter, details are to be submitted for approval.
5. Locking arrangements are to be incorporated in rudder coupling bolts.

8.8 Figures and illustrations

8.8.1 Dry exhaust system

The exhaust system and piping should be leakproof to prevent toxic fumes from fouling the accommodation spaces.
 Pipes should be insulated, as dry system gets very hot.
 There must be at least 100mm clearance for any wood or FRP material.

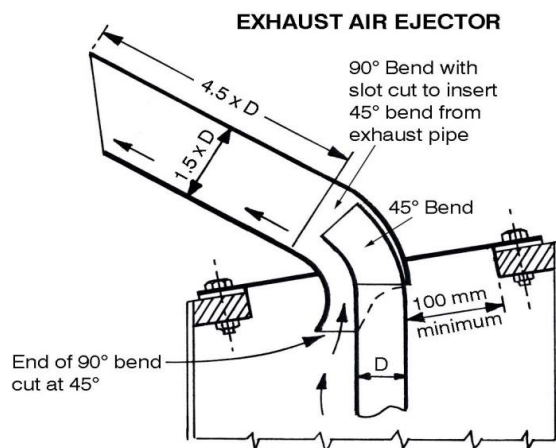
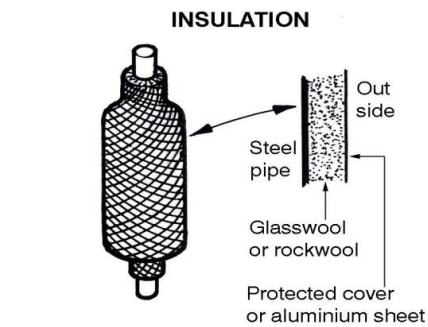
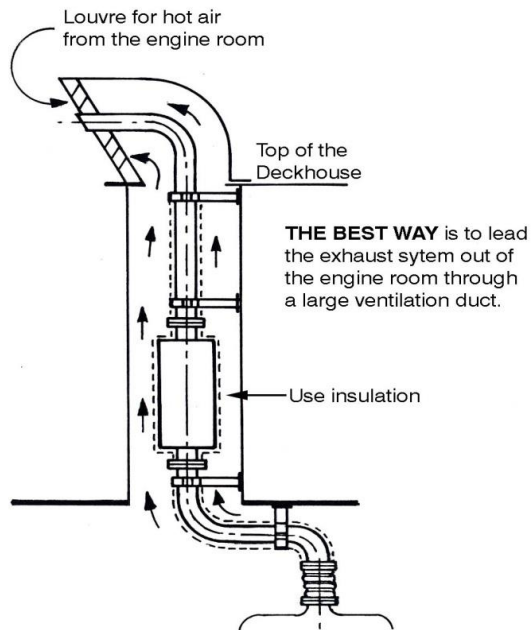
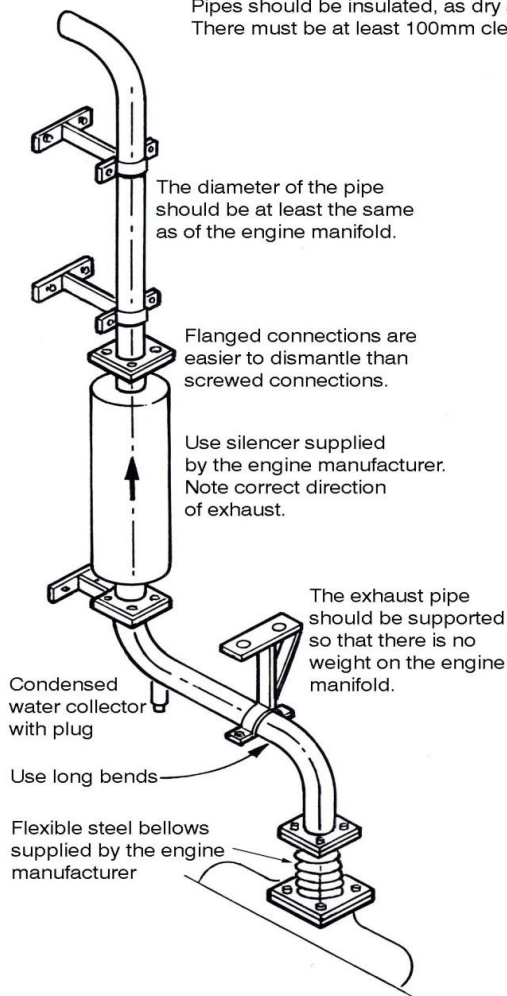

The ejector will suck warm air from the engine room and improve ventilation considerably. Based on recommendations from Caterpillar Diesels Ltd.