

Drawing No.
S 25 sheet
 1 of 3

Before using this drawing, confirm
 that it has not been superseded.

© CROWN COPYRIGHT

- NOTES: 1. The grids do not form part of any
 sign to which the symbols are applied.
 2. Dimensions are given in grid divisions.

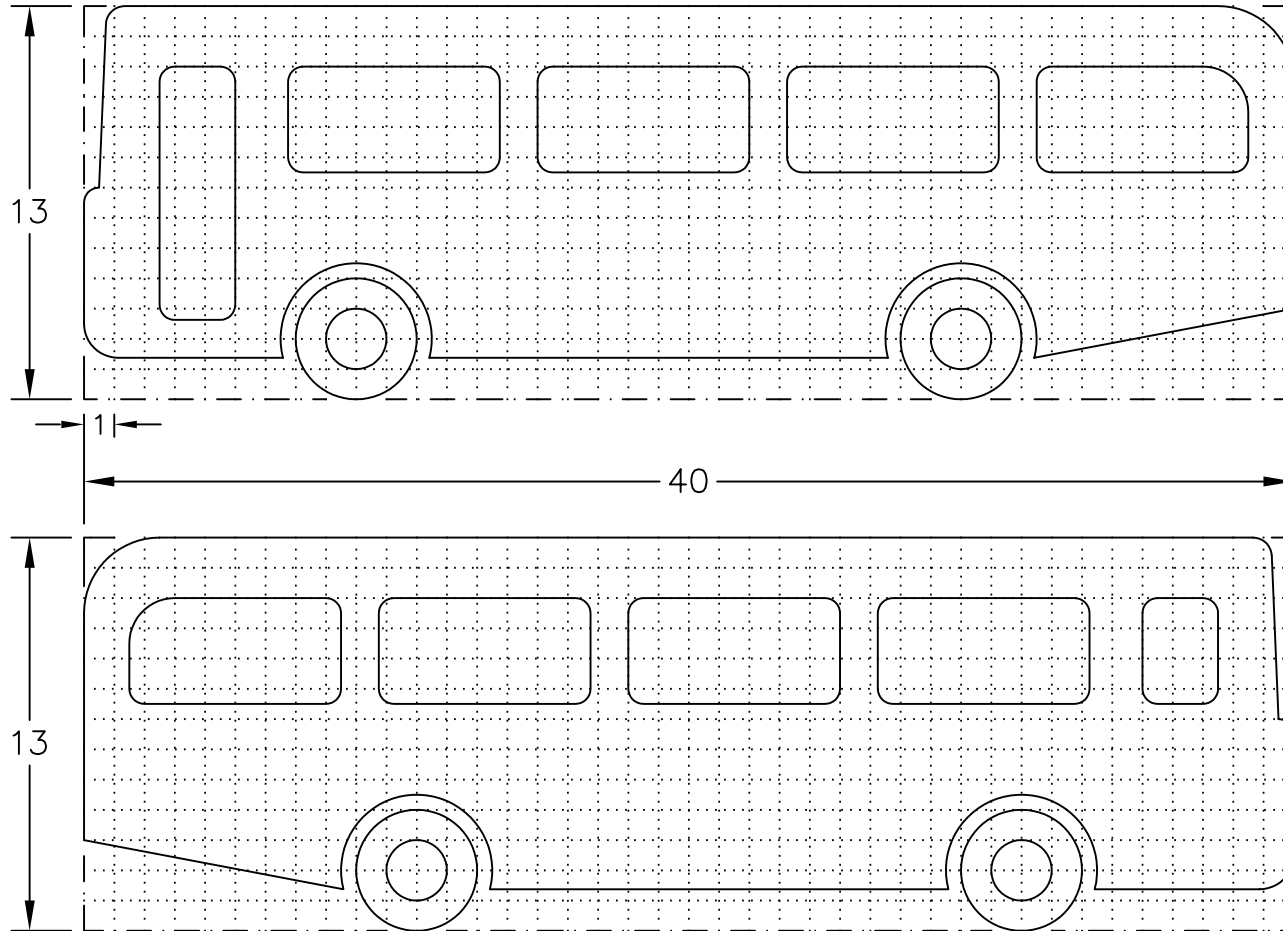

(see sheet 2 for word 'local' on side)
 (see sheet 3 for prohibition with red bar)

S25-1

Department for Transport	Title:	Symbol	Issue:	Date:	Drawn by:	Dimensions:	Drawing No.
		BUS	A:	1.7.94	S.P.	ALL IN GRID DIVISIONS	S 25 sheet 1 of 3
			B:	12.11.02	Approved by:		
			C:		R.M.		

Drawing No.
S 25 sheet
2 of 3

Before using this drawing, confirm
that it has not been superseded.

© CROWN COPYRIGHT

NOTES:

1. The grids do not form part of any sign to which the symbols are applied.
2. Dimensions are given in grid divisions.
3. The legend is from the Transport Heavy alphabet at the x-height shown.
(The letters are always in black)

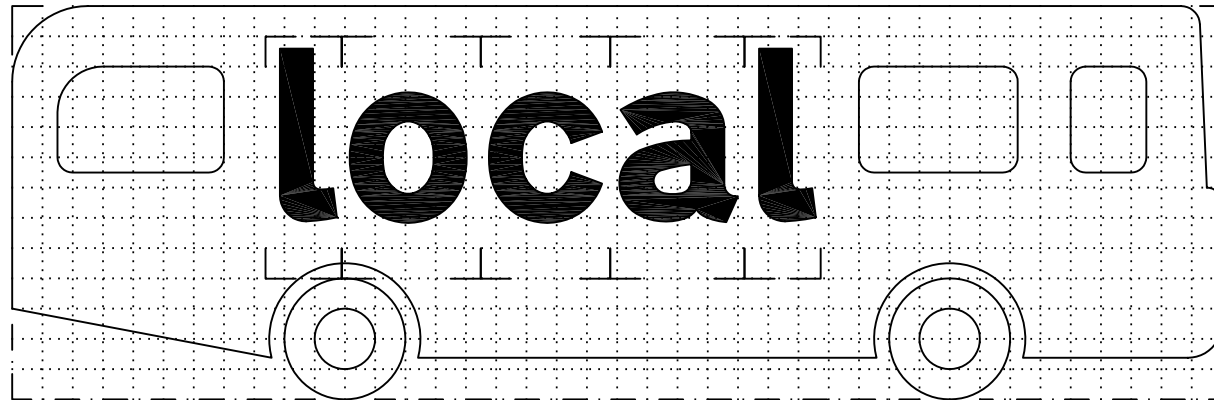
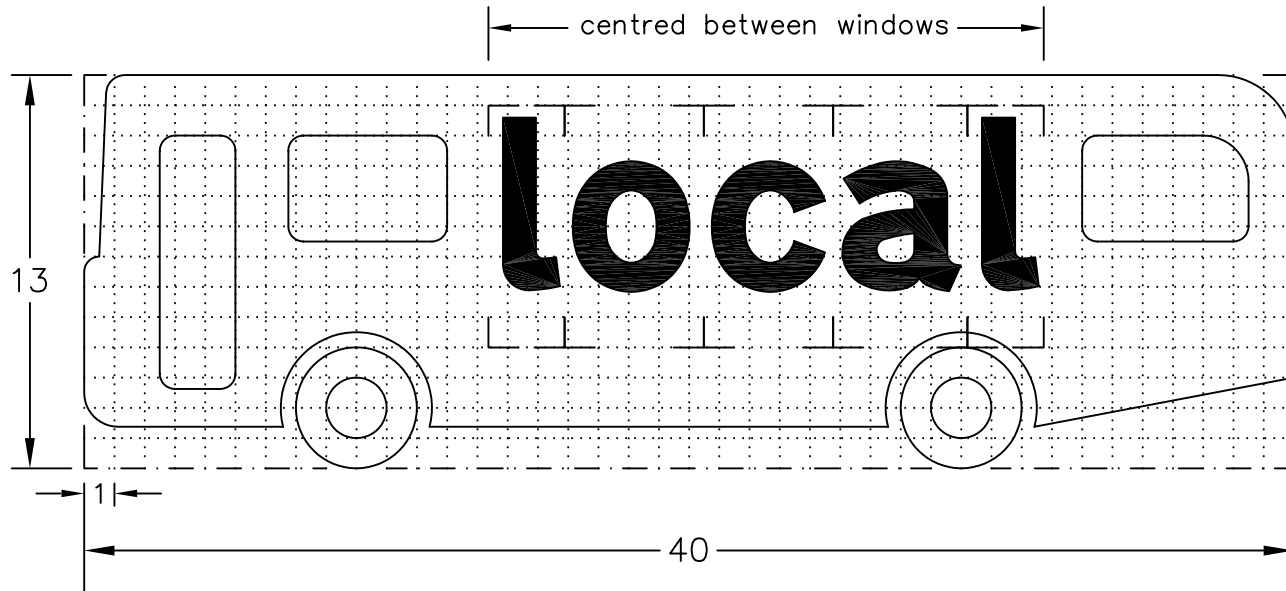

4
x-ht
(in grid
divisions)

(see sheet 1 for symbols without words on side)
(see sheet 3 for prohibition with red bar)

S25-2

<p><i>Department for</i> Transport</p>	Title:	Symbol	Issue: Date:	Drawn by:	Dimensions:	Drawing No.
		LOCAL BUS	A: 18.8.94	S.P./R.M.	ALL IN	S 25 sheet
			B: 12.11.02	Approved by:	GRID DIVISIONS	2 of 3
			C:	R.M.		

Drawing No.
S 25 sheet
3 of 3

Before using this drawing, confirm
that it has not been superseded.

© CROWN COPYRIGHT

- NOTES: 1. The grid does not form part of any sign to which the symbol is applied.
2. Dimensions are given in grid divisions.
3. The bus is identical to the one shown on sheet 1 but at 75% scale on the grid and with a portion removed to add the red prohibition bar.

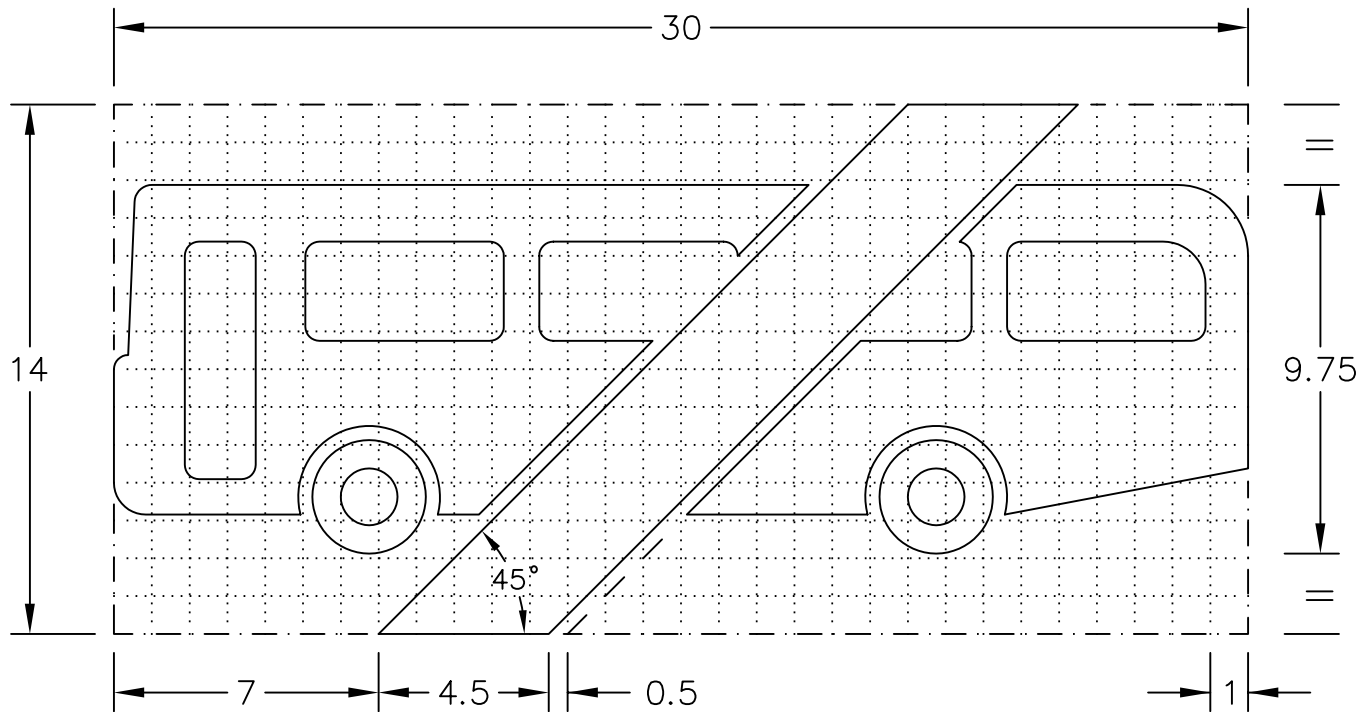

(see sheet 1 for symbol without red bar)
(see sheet 2 for word 'local' on side)

S25-3

Department for Transport	Title:	Symbol	Issue:	Date:	Drawn by:	Dimensions:	Drawing No.
	BUS PROHIBITION		A:	1.7.94	S.P.	ALL IN GRID DIVISIONS	S 25 sheet 3 of 3
			B:	12.11.02	Approved by:		
			C:		R.M.		