



Defence
Safety Authority

DSA 03.OME Part 2 (JSP 482) - Defence Code of Practice (DCOP) and Guidance Notes for In-Service and Operational Safety Management of OME

Defence OME Safety Regulator

DOSR



DSA VISION

Protecting Defence personnel and operational capability through effective and independent HS&EP regulation, assurance, enforcement and investigation.

PREFACE

AUTHORITY

1. This document is crown copyright and the intellectual property rights of this publication belong exclusively to the Ministry of Defence (MOD). However, material or information contained in this publication may be reproduced, stored in a retrieval system or transmitted in any form provided it is used for the purposes of furthering safety and environmental management.

STATUS

2. This document:
 - a. Is uncontrolled when printed.
 - b. Will be updated as part of a continuous improvement programme but at least 12-monthly from the period of document issue date.

REQUESTS FOR CHANGE

3. Proposed changes, recommendations or amendments to DOSR Regulations and Guidance publications can be submitted by anyone using the DOME Request for Change Function (RFC) available for every Dome publication in the DOME library located [here](#) or by completing the Word version of the Change Proposal Form available from the DOME Library, see figure 1 below for the location.

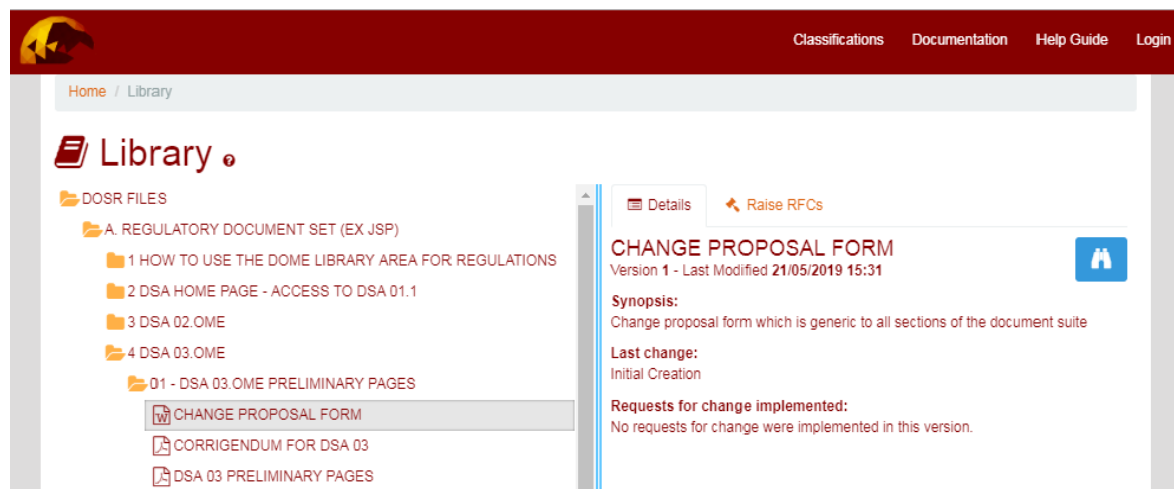

Figure 1. Change Proposal Form (Word version) Location

4. Any post and grammar change proposals can be approved or rejected by the DOSR PRG Authors without involvement of the associated Working Group.
5. Technical change proposals will need to be submitted to the associated Working Group for review and approval or rejection.
6. When incorporating changes care is to be taken to maintain coherence across regulations.
7. Changes effecting Risk to Life will be published immediately.
8. Other changes will be incorporated as part of routine reviews.

REVIEW PROCESS

9. The DOSR PRG team will ensure these OME Regulations remain fit for purpose by conducting reviews through the DOSR Governance Committees, involving all Stakeholders.

FURTHER ADVICE AND FEEDBACK

10. The document owner is the DOSR. For further information about any aspect of this document, or questions not answered within the subsequent sections, or to provide feedback on the content, contact:

Job Title	DOSR-Policy, Regulations and Guidance
E-mail	DSA-DOSR-PRG@mod.gov.uk
Address	Juniper #5004, Level 0, Wing 1, Abbey Wood North, Bristol, BS34 8QW

Intentional Blank Page

CHAPTER 13**STORAGE AND HANDLING OF EXPLOSIVES****CONTENTS**

Paragraph

- 1 STORAGE AND HANDLING OF EXPLOSIVES
 - 1.1 Introduction
- 2 GENERAL EXPLOSIVES STORAGE PRINCIPLES
 - 2.1 Introduction
 - 2.2 Storage Capacity and Space Requirement
 - 2.3 Examination of Packages and Unboxed Munitions
 - 2.4 Storage by Nature
 - 2.5 Storage by Hazard Division
 - 2.6 Storage by Compatibility Group
 - 2.7 Sealing of Packages
 - 2.8 Priority of Issue
- 3 SPECIFIC EXPLOSIVES STORAGE PRINCIPLES
 - 3.1 Isolation and Segregation
 - 3.2 Isolated Storage Requirements
 - 3.3 Disposal Actions for Isolated Explosives
 - 3.4 Storage of Damaged or Misfired Ammunition
 - 3.5 Earthing Requirements for Ready-Use Stocks
 - 3.6 Radio Frequency and Electro-Static Hazards
 - 3.7 Storage of Experimental Explosives and Explosives Under Trial
 - 3.8 Storage of Commercial Explosives
 - 3.9 Storage of Explosives Ordnance Disposal Arisings
 - 3.10 Storage of Air Weapon Pellets
 - 3.11 Storage of Radioactive Stores
 - 3.12 Storage of Fireworks
 - 3.13 Storage of Explosives Held in Safe Custody as Police Evidence
- 4 DANGEROUS GOODS OF NON-EXPLOSIVE CATEGORIES, WEAPONS FILLED WITH NON-EXPLOSIVES DANGEROUS GOODS, GENERAL STORES AND FIREARMS
 - 4.1 Storage
 - 4.2 Items Excluded From Class 1
 - 4.3 General Stores
 - 4.4 Empty Packages / Expended Cartridge Cases
 - 4.5 Non-Explosive Items / Components
 - 4.6 Firearms

5 PRESERVATION OF OPERATIONAL CAPABILITY

- 5.1 Dispersal of Stocks
- 5.2 Temperature
- 5.3 Turnover of Stocks
- 5.4 Prevention of Deterioration of Explosives
- 5.5 Ready use Munitions
- 5.6 Storage Conditions

6 EXPLOSIVES HANDLING PRINCIPLES

- 6.1 General
- 6.2 Explosives Handling – Safety
- 6.3 Damage During Handling
- 6.4 Palletisation - Pallet Construction and Handling
- 6.5 Unit Loads Destined for Support Ships and Warships

7 STACKING OF EXPLOSIVES

- 7.1 Introduction
- 7.2 General Stacking Criteria
- 7.3 Operational Explosives
- 7.4 Use of Stack Cards and Pallet Contents Sheets
- 7.5 Spacing of Explosives from PES Structure
- 7.6 Stacking of Loose Packaged (Unpalletised) Explosives
- 7.7 Unpackaged Explosives
- 7.8 Palletised Stores

8 SPECIFIC METHODS OF STACKING

- 8.1 Self-Propulsive Missiles
- 8.2 Unboxed Shell
- 8.3 Aircraft Bombs
- 8.4 Multiple Launch Rocket System (MLRS)
- 8.5 White Phosphorus (CG 'H') Explosives
- 8.6 Storage of Explosives in Compatibility Group L
- 8.7 Ammunition Containing Depleted Uranium

9 USE OF RACKING

- 9.1 General
- 9.2 CG 'H'

10 STACKING OF LOADS USING MECHANICAL HANDLING EQUIPMENT

- 10.1 Specifications for Mechanical Handling Equipment
- 10.2 Movement of Palletised Loads Using Mechanical Handling Equipment
- 10.3 Use of Lifting/Slings Gear with Explosives
- 10.4 Ferrous Slings
- 10.5 Multi-Legged Slings
- 10.6 Slings of Loads

11 UNDERGROUND STORAGE AREAS

- 11.1 Introduction
- 11.2 Stacking
- 11.3 Repair and Maintenance
- 11.4 Records
- 11.5 Prohibited Storage
- 11.6 Limitations in Underground Storage
- 11.7 Fire Precautions
- 11.8 Mechanical Handling Equipment
- 11.9 Humidity
- 11.10 Non-Explosives Dangerous Goods

Fig

- 1 MLRS Dunnage Manufacture and Method of Fitting in the Stack

Annex

- A Approval to Store and Handle Explosives (ASHE)
- B Calculation of Storage Capacity and Space Requirement
- C Hazard Divisions
- D Compatibility Groups
- E Mixing of Compatibility Groups in Above Ground Storage
- F Storage of Explosives Ordnance Disposal Arisings
- G Responsibility for the Care and Maintenance of Ammunition in the Field
- H Ready Use Munitions
- I Storage of Explosives Held in Safe Custody as Police Evidence
- J Storage of Explosives in the Field and Under Emergency Conditions

1 STORAGE AND HANDLING OF EXPLOSIVES

1.1 Introduction

1.1.1 This chapter details the general practical conditions for storage and handling of explosives, UN Dangerous Goods Class 1, and is amplified by other chapters within this publication or within the technical publication for the explosive nature concerned. It should be read, where applicable, in conjunction with the DSA03 DLSR Movement and Transport Safety Regulations, Dangerous Goods Manual (DGM).

1.1.2 Before being stored or handled, all Military Explosives (see Definitions) must be classified for storage and transportation by the DOSR under the procedure detailed in Chapter 4. A classification is only valid for explosives in their approved packages or, if normally an unpackaged item, when fitted with their approved transit devices the Munitions Packaging Database (MPD) gives details of the authorised packaging to be used. Explosives are not generally to be over-packed unless the packaging forms part of the original specification as submitted for DOSR classification or is required for other reasons (such as carriage by air).

1.1.3 Sponsors are to ensure that all relevant information on specific storage and handling requirements is provided before any explosives are accepted into an explosives facility.

1.1.4 This is achieved for military and commercial explosives stored and handled by DM by subjecting them to a prior acceptance for storage and handling formal approval procedure, known as the 'Approval to Store and Handle Explosives' (ASHE), see Annex A.

2 GENERAL EXPLOSIVES STORAGE PRINCIPLES

2.1 Introduction

2.1.1 The overriding principle is that explosives are to be stored safely and securely in the licensed accommodation provided. Where suitable explosives storage facilities are not adequate, or are not immediately available, the HoE is to request advice from the IE concerned.

2.1.2 Under normal circumstances, explosives storage facilities are not to be used for the storage of other equipment, materiel or Dangerous Goods.

2.2 Storage Capacity and Space Requirement

2.2.1 The floor space requirements for storage of explosives will depend on the size of the items or packages and the maximum permitted stacking height of the explosives in question, or the height available if this is less (see Annex B).

2.2.2 As it is necessary to allow for gangways, working space, short stacks etc, only a proportion of the total cubic capacity of a building may be taken as the effective capacity for the storage of explosives. Normally the effective capacity is to be assessed as 50% of the floor area multiplied by the height of the stacks. For storage to NATO criteria however, the capacity is to be assessed as 70% of the floor area multiplied by the height of the stacks.

2.2.3 Although the effective capacity of a PES is the factor most likely to limit the amount of explosives that can be accommodated, it is also governed by the Hazard Division and Compatibility Group of the explosives to be stored and the available QDs.

2.3 Examination of Packages And Unboxed Munitions

2.3.1 Where possible all containers and unboxed shell are to be thoroughly dried and cleaned of mud and dirt before acceptance into the store. Care is to be taken to avoid defacing markings and paintwork during cleaning.

2.3.2 Additionally, pallets, packages or unboxed munitions are to be examined for damage, signs of tampering with seals, etc. If damage or signs of tampering are detected then the pallet, package or munition should be segregated for detailed examination.

2.3.3 Defective packages are normally to be repaired or replaced before storage is permitted. This work is to be carried out in a Process Building. Exceptionally, defective/damaged packages may, after inspection by a competent person, be kept in segregated storage until repaired.

2.3.4 If the seal of a package is broken or missing and the package concerned is not for immediate use, the inner packaging and contents are to be examined and, if found satisfactory, the package is to be correctly sealed in accordance with this document, before storage is permitted. This work is to be carried out in a Process Building.

2.4 Storage by Nature

2.4.1 Where possible, a PES should contain only one explosives nature.

2.4.2 When it is essential to store more than one explosives nature in a PES, the regulations in Annexes C and D regarding Hazard Divisions and Compatibility Groups must be applied.

2.5 Storage by Hazard Division

2.5.1 Explosives are divided into six HDs according to the hazards they present when initiated (see Annex C). To minimize the hazard, buildings containing explosives are sited at prescribed distances from each other and from other buildings and installations inside and outside the explosives area. These distances are known as QDs and they limit the permissible NEQ for each HD or combinations of HDs that may be stored in a building or site. There are regulations governing the aggregation of mixed HDs and, where this is likely to occur, the Technical Explosives Authority is to be consulted.

2.6 Storage by Compatibility Group

2.6.1 In addition to the HDs each article of ammunition has been assigned to one of thirteen Compatibility Groups (CGs), indicated by the letters A to H, J, K, L, N and S, to ensure the correct segregation during storage and transportation. These Groups have been defined so that, with the exception of CGs L and N, all explosives in the same group are compatible with each other in storage and transportation. See Annex D and E.

2.6.2 There may be special circumstances where the mixing rules prescribed in Annex E are modified by DOSR or DSA DOSR CIE (MOD), subject to appropriate testing leading to adequate technical justification.

The mixing rules detailed in Annex E apply to above ground storage only.

2.6.3 The permitted mixing of CGs during transportation is covered by the regulations in the Dangerous Goods Manual (DGM) - covering road, rail, sea and air.

2.6.4 The HDs and CGs form the Hazard Classification Code (HCC) which is a three character code consisting of two numerals and one letter, e.g. 1.4S.

2.7 Sealing of Packages

2.7.1 Packages housing ammunition are sealed, with the seal marked with a monogram. This denotes where or by whom the container was last sealed and is intended to be a guarantee of contents.

2.8 Priority of Issue

2.8.1 Normally, explosives of the earliest date of manufacture are to be expended first but see below. Once the issue of a particular BKI batch, lot or work date has commenced it is to continue until fully expended, where practicable, unless any restriction is placed on it.

2.8.2 To avoid the necessity of replacing, at short intervals, stocks that have become unserviceable through deterioration by age, issues to overseas units may be made from the newest stock.

2.8.3 Once a hermetically sealed container has been opened its contents are to be earmarked for early use.

2.8.4 Explosives issued to the user which have been unpackaged, but not expended, are to be repackaged in their correctly marked authorised Service container, including inner fittings, before being put to store. They are to be held as first for issue.

3 SPECIFIC EXPLOSIVES STORAGE PRINCIPLES

3.1 Isolation and Segregation

3.1.1 Explosives known or suspected of being unsafe, or whose condition/performance is uncertain, are to be the subject of action in accordance with the instructions contained in this document. When the situation warrants it, Serious Fault reporting action is to be taken in accordance with Chapter 27, or as directed by the PT for the explosive concerned. As soon as practicable, but within 5 working days, the PT is to decide on the need for isolated or segregated storage and arrange for the issue of an Explosives Constraint. Explosives are to be isolated or segregated as follows:

- (1) Isolation. The following explosives are always to be isolated:
 - (a) Repairable or unserviceable explosives that are, or are suspected of being, unsafe.
 - (b) Salvaged stores¹ recovered after an accident, explosion, fire or a trial.
 - (c) Stores which have failed to function and are unsafe for use, but not unsafe for storage.
 - (d) Explosives recovered during EOD operations.
 - (e) On instruction of an PT, an IE Inspector or an ATO.
- (2) Segregation. The following stores are always to be segregated.
 - (a) Stores known to be unserviceable or suspected of being faulty but which are not unsafe.
 - (b) Service Life expired stores.

¹ Also known as 'Casualty Weapons'

- (c) Experimental explosives and explosives under trial.
- (d) Enemy explosives.
- (e) Commercial explosives.
- (f) Banned munitions which are safe for storage.

3.2 Isolated Storage Requirements

3.2.1 A PES used for the storage of explosives requiring isolated storage is to be sited such that all ES are afforded the quantity distance (QD) protection given by the tables in Chapter 10. Reduced QDs are not permitted. Explosives requiring isolated storage are not normally to be mixed by compatibility group. However, small quantities (i.e. less than 10 kg NEQ) of any compatibility group requiring isolated storage may be stored in the same PES under the following conditions unless storage is at an EOD unit which are subject to individual licence limits (see also Annex F):

- (1) Explosives of each compatibility group are effectively segregated from explosives of any other compatibility group by walls of autoclaved aerated concrete blocks.
- (2) No explosives of HD 1.1 are stored.
- (3) The normal mixing of compatibility groups is permitted for explosives requiring segregated storage (see Annex E).

3.3 Disposal Actions for Isolated Explosives

3.3.1 Explosives requiring isolated storage are to be disposed of as soon as practicable. IE Inspectors will check that items are being stored in isolation for only the minimum practicable time, and long term isolated storage of explosives will require justification. Failure to provide adequate justification may result in an adverse comment. A constraint is not to be removed from suspect stores until one of the following conditions has been satisfied:

- (1) Clearance or disposal is authorised either by the PT for the store concerned.
- (2) In the case of explosives which do not have a designated PT (e.g. munitions left by Visiting Forces), the appropriate IE has issued disposal instructions.

Where necessary advice may be sought from the appropriate IE or, ultimately, CIE (MOD) staff.

3.4 Storage of Damaged or Misfired Ammunition

3.4.1 Damaged and misfired ammunition is not to be stored except as listed below. Damaged and misfired ammunition that cannot be stored is to be reported to the Technical Explosives Authority or if on an authorised range disposed of in accordance with the relevant regulations.

3.4.2 Damaged or misfired Small Arms Ammunition (SAA), calibre below 12.7mm, may be held in a unit store. These rounds are to be placed in a closed metal Service ammunition container marked "Damaged or Misfired SAA". The container is to be segregated to await collection by the Technical Explosives Authority.

3.4.3 Misfired electric primers (including conducting composition primers) and igniters cartridge (electric) may be held in a unit store. They are to be placed in a closed metal Service ammunition container marked "Misfired electric primers". The container is to be segregated to await collection by the Technical Explosives Authority.

3.4.4 Damaged ammunition (except items described at sub paragraphs above) discovered in an ammunition store is to be left as it is found and is to be immediately reported to the Technical Explosives Authority.

3.5 Earthing Requirements For Ready-Use Stocks

3.5.1 Ready use stocks that are stored on trolleys and mobile racking are not to be connected by an earth lead to the PES internal bonding strip during storage unless specified by the relevant PT. In the event of a lightning strike on the PES, this could lead to the items being rendered unserviceable.

3.6 Radio Frequency And Electro-Static Hazards

3.6.1 Radio frequency (RF) radiation and electrostatic charges can affect electrically initiated explosive devices (EEDs – see Definitions and JSP 412). In all circumstances, EEDs are subject to the HERO safety distances detailed in Chapter 24 and to any other precautions detailed in the technical publication for the item concerned.

3.7 Storage of Experimental Explosives and Explosives Under Trial

3.7.1 They are to be segregated from other natures within the storage facility. The owner or sponsor of the explosives must provide disposal instructions before acceptance into storage and the explosives may be destroyed, returned to the owner/sponsor, transferred to another location or retained for a pre-determined time. In the case of the latter, contact is to be made with the owner/sponsor at least every 6 months. To ensure they retain their identity at all times, the packages and contents are to be marked with an identification symbol(s), taken from Def Stan 00-810, that will ensure each item, if unused, is returned to its correct package. Additionally, the packages or stacks are to be clearly marked with the sponsor details and a trial reference number (if applicable).

3.8 Storage of Commercial Explosives

3.8.1 Commercial explosives supplied to the MOD for use or appraisal must comply with CLER and PEC.

3.8.2 Commercial explosives may be held by the MOD when they form part of a MOD contract or are a contract entered into by the Secretary of State for Defence. They are to be classified by DOSR, and authorised by the IE, prior to storage and are to be kept segregated.

3.8.3 All commercial explosives have a limited life. Storage records must indicate the shelf life of the item.

3.8.4 Privately owned commercial explosives other than Fireworks belonging to Service personnel, MOD employed civilians or Multi Activity Contractors may be stored for safe custody purposes in a licensed PES, subject to the written permission of the HoE, in accordance with the appropriate regulations, under the following conditions:

- (1) They have been classified by DOSR.

(2) The owner is to have, if required, a civilian firearms certificate that authorises him to possess the explosives. If doubt exists on the need for a certificate, advice should be obtained from the local civilian Police.

(3) The owner is to have, if required, certification in accordance with the Explosive Regulations 2014.

(4) On receipt, the items are to be inspected by a competent person. Items that are in poor condition or have been subject to local modification are not to be accepted for storage. This receipt inspection is to include checking for compliance with PEC and CLER, and packaging must be in accordance with the UN 'Orange Book' requirements.

(5) Approval has been given by the Technical Explosives Authority.

3.9 Storage of Explosives Ordnance Disposal Arisings

3.9.1 The regulations pertaining to Explosives Ordnance Disposal Arisings are at Annex F.

3.10 Storage of Air Weapon Pellets

3.10.1 Air Weapon Pellets are to be treated as explosives for the purpose of security and accountability.

3.11 Storage of Radioactive Stores

3.11.1 Radioactive stores should not be stored within the Outside Quantity Distance (OQD) of the explosives store. When this is considered to be impracticable the advice of the Technical Explosives Authority is to be obtained.

3.12 Storage of Fireworks

3.12.1 For information on the storage of fireworks see Chapter 17 Annex C.

3.13 Storage of Explosives Held in Safe Custody as Police Evidence

3.13.1 For information on the storage of explosives held in safe custody as Police Evidence see Annex I.

4 DANGEROUS GOODS OF NON-EXPLOSIVE CATEGORIES, WEAPONS FILLED WITH NON-EXPLOSIVE DANGEROUS GOODS, GENERAL STORES AND FIREARMS

4.1 Storage

4.1.1 Non explosive dangerous goods are not normally to be stored in a PES or explosives area because of the additional hazards that may be introduced by their presence. However, certain explosive natures, or their components, contain dangerous goods that are required to be stored because they are related by function to the explosives (e.g. Pyrophoric ac IR Flares, or missile fuels). It is permissible to store these explosives related dangerous goods in a PES or explosives area provided that they are treated as HD 1.3 for QD purposes. However, the items and their outer packages are not to be marked with HD 1.3 labels. Such storage must be specifically authorised by the relevant IE.

4.2 Items Excluded From Class 1

4.2.2 When an item containing explosives has been considered by DOSR to present no significant hazard from explosion and has been excluded from Class 1 it will be listed on the

DOME database with a DOSR number prefixed by "N". These items may be stored with the explosives items that they are related to but should be treated as HD 1.4S for storage purposes. However the items and their packages are not to be marked with HD 1.4S labels.

4.3 General Stores

4.3.1 Storage of general stores in an explosives storage area is forbidden. The safety measures in place are designed to protect as far as possible the Explosives Workers and Explosives Area Support Workers operating inside the area, and there are strict limits. Additional activities inside the storage area are not catered for in the safety calculations and will impinge on the operation of the explosive storage area as it significantly increases societal risk.

4.4 Empty Packages / Expended Cartridge Cases

4.4.1 With the exception of Process Buildings, empty packages and brass salvage are not to be kept in a PES, but are to be removed as soon as possible after emptying, transported directly to a place set aside for their storage, and dealt with accordingly.

4.4.2 SAA cartridge cases (under 12mm) can be stored with HD 1.4S.

4.5 Non-Explosive Items / Components

4.5.1 Drill, instructional or dummy stores or weapons, whether empty or inert filled, are not to be stored with live stores to avoid inadvertent mixing in use. They should be stored outside the explosives area. All drill, instructional and inert filled stores that have been converted from filled stores are to be submitted for inspection before they are taken into use. Such stores are to conform to an approved design and prior authority for their conversion is to be obtained from relevant PT.

4.5.2 Non-explosive components which are related by function to explosives e.g. shear-wires etc, may be stored in the same storehouse as their parent stores. The packages are to be properly sealed and identified, and they are to be stacked separately from the filled stores.

4.5.3 Packaged non-explosive components are to be stacked by reference number, lot/batch number or mark/model and date of manufacture.

4.5.4 there is no height restriction for stacking non-explosives, unless the relevant PT details otherwise, but consideration should be given to the stability of the stack and designed stacking height of large containers. The number of tiers to a stack is to be reduced if there are any signs of damage to containers in the lower tiers.

4.5.5 Cylindrical aircraft bomb tail unit containers are normally stacked on their bases. When, due to container design, it is not possible to achieve stability in stacks by vertical storage, containers may be stacked horizontally. In these instances, consideration must be given to the security of the tail unit within the container and the protection provided. Dispensation may also be given for horizontal stacking to reduce water retention on containers.

4.6 Firearms

4.6.1 Storage of firearms, e.g. rifles, pistols and tasers are prohibited with ammunition unless specifically authorised.

5 PRESERVATION OF OPERATIONAL CAPABILITY

5.1 Dispersal of Stocks

5.1.1 It is imperative to preserve operational capability and to reduce the risk of the total stock of an item being destroyed in a fire or explosion. Normally therefore, not more than 50% of each explosive nature, and associated non-explosives components, are to be stored in any one PES and where reasonably practicable, this stock is to be further dispersed. However, in cases where the loss of certain types of stocks (e.g. small arms ammunition, ground defence explosives, pyrotechnics etc) will not significantly affect the operational capability of a unit, the dispersion of stock is to be treated as desirable rather than essential.

5.2 Temperature

5.2.1 Certain explosives are adversely affected by extremes of temperature.

5.3 Turnover of Stocks

5.3.1 Explosives deteriorate with age, become less effective or reliable in use, and in some instances, more dangerous to handle and store. Poor storage conditions and/or extremes of temperature hasten the rate of deterioration of certain explosives.

5.4 Prevention of Deterioration of Explosives

5.4.1 The service/operational life of many explosives commences when the packaging is first opened. The safe life of explosives commences on the day of manufacture of the explosives fill. The PT for the store is responsible for promulgating safe and service/operational life information which is published in the Joint Services Munitions Control Register (JSMCR). Effective systems are to be in place to ensure that affected explosives are managed and inspected in accordance with the technical publication relevant to the item concerned (see also Annex H).

5.5 Ready Use Munitions

5.5.1 See Annex H for information on maintaining the serviceability of munitions held at ready use positions.

5.6 Storage Conditions

5.6.1 Covered Storage - All explosives and associated non-explosives stores and 'dangerous goods', with the exception of aircraft HE bombs and similar stores held in temperate climates, are normally to be stored under cover. All aircraft HE bombs held in sub-tropical and tropical climates must be provided with protection from the sun. This may be by using a building or structure fitted with approved air conditioning.

5.6.2 Some explosive stores are more vulnerable to the elements and where covered storage is limited, the following provisions should be applied. Where there is insufficient covered storage accommodation available, the following points are to be taken into consideration when allocating buildings:

- (1) The prior authority of the relevant PT, through the relevant IE, is to be sought.
- (2) The inherent liability of particular explosive stores to damage from exposure.
- (3) The design of the packages to resist exposure, and their condition.

- (4) The type of storage required by regulation, i.e. magazine or storehouse.
- (5) The availability of the explosives in theatre and the prospects for re-provisioning.
- (6) The prevailing climate.
- (7) The need for the security of certain items, e.g. ACTO.
- (8) The special risks from exposure if the condition of the explosives is doubtful.

5.6.3 Open Storage - Where it is necessary to store explosives (except iron bombs and robust shell) in the open, the stacks should be covered with waterproof sheets (preferably fire resistant) or other suitable material. The sheets should be supported in such a way as to allow a current of air to circulate over and around the stacks. When supports are not available and the sheets have to be laid directly on the stacks, every opportunity is to be taken to air the stores by uncovering them periodically in favourable weather. As a minimum the stores should be aired at least monthly, and more frequently if the prevailing climatic conditions in theatre warrant it.

6 EXPLOSIVES HANDLING PRINCIPLES

6.1 General

6.1.1 It cannot be over emphasised that all personnel are to exercise the greatest possible care at all times when handling explosive stores. This rule applies not only to personnel employed in an explosives facility but also to those engaged in the transportation of explosives.

6.2 Explosives Handling – Safety

6.2.1 Reference should be made to the applicable technical publication or departmental safe systems of work for the actual handling requirements for specific explosives articles and substances (see Definitions).

6.2.2 Careless or rough handling may not only cause visual damage to ammunition but can also affect the internal mechanisms of components which cannot be detected. Such damage may render the ammunition unserviceable or unsafe to use.

6.2.3 Ammunition containers are specifically designed to protect ammunition during storage and transportation. Damage to a container through careless handling may directly affect the contents; it may also reduce the effectiveness of the protection provided to the contents which could consequently deteriorate. Identification markings may also become obliterated or difficult to decipher.

6.2.4 All explosives must be handled with proper care and at no time should explosives safety be compromised in the interest of speed or expediency. Rough handling is to be avoided at all times as this is liable to cause a fire or explosion, make unsafe for continued storage or handling, or failure in operation. If they cannot be lowered to a hard surface without unacceptable impact, suitable padding material must be employed to cushion the impact.

6.2.5 Handling of explosives is normally to be conducted during daylight hours. Where this is impractical, adequate lighting must be provided to ensure that explosives can be handled in the safest manner.

6.2.6 Explosives as packaged, loose or as palletised loads must not be slid, rolled, dropped or exposed to possible misuse. Packages being moved using gravity rollers must not be allowed to collide with each other, nor are they to be propelled carelessly or violently.

6.3 Damage During Handling

6.3.1 Explosives or explosives packages that are damaged, found to be damaged or suspected of being damaged during handling are to be segregated and inspected by a competent person. In cases where damage is as the result of an accident or incident. Where damage is caused by a major impact, and results in explosives being exposed or leakage of liquid, then the item/package is not to be touched, the area is to be vacated and the incident reported immediately.

6.4 Palletisation - Pallet Construction and Handling

6.4.1 Palletisation may be adopted for all Compatibility Groups except K and L.. Standard palletisation instructions for explosives are detailed in the Munitions Packaging Database (MPD) MHTU/52CM01/93, STANAG 2828. Pallets used for palletising explosives stores must be 2 Tonne NATO Standard pallets. Pallet construction must meet the requirements of STANAG 2828 and comply with the Unit Load Build Specification.

6.4.2 Explosives in CG K and CG L are not to be palletised.

6.4.3 Wherever possible, packages containing explosives should be palletised in accordance with their relevant Unit Load Specification. Where this is not practicable, such as when only small quantities are required for issue, or there is a mixture of different types and size of package, the following points are to be considered:

- (1) Where mixing of packages in one load is unavoidable, account must be taken of the drop height limitations for each separate nature to ensure that packages with drop height restrictions are not mixed with those that do not.
- (2) Only serviceable pallets or post/cage pallets of an approved pattern are to be used.
- (3) Weight/size limitations of the pallet must not be exceeded.
- (4) Packages are to be strapped / secured to the pallet to prevent movement or spillage.

6.5 Unit Loads Destined For Support Ships And Warships

6.5.1 Due to height constraints within Holds and the lifting capacity of the MHE on Afloat Support ships and Warships, the height and weight of palletised stores must not exceed 1050mm and 1200kg respectively. However, loads more than this height and weight need not be re-palletised unless specifically destined for such vessels.

7 STACKING OF EXPLOSIVES

7.1 Introduction

7.1.1 The packaging of explosives and associated components provides a major contribution towards maintaining their safety, serviceability and reliability. The improved design of packages, mitigation in packages, and the increasing use of the all-up-round (AUR) packaging concept has resulted in high cost packaging which must be preserved because of the nature of the contents and to ensure a long economical in-service life. Wherever possible packaging and ancillaries used for packing must be retained for reuse.

7.1.2 The purpose of these paragraphs is to detail the principles of stacking to be followed to ensure safety and the serviceability of packages, and to achieve efficiency in storage, accounting and handling. Firm, level surfaces and appropriate floor design loadings are a fundamental necessity, and are assumed throughout. Unless detailed below, the relevant PT is responsible for detailing specific stacking heights or restrictions and these should be stated in the safe system of work.

7.2 General Stacking Criteria

7.2.1 The following criteria apply to the stacking of packaged, unpackaged, palletised explosives:

- (1) All packages and unpackaged items should be dry and clean before being placed in storage.
- (2) Items bearing lot or batch numbers should be stacked by mark or model number, filler / manufacturer, date and lot or batch/BKI number. It is not necessary to leave a lateral gangway between each lot or batch/BKI.
- (3) Pallets and loose packages should be stacked so that identification markings can be easily seen without disturbing the stack.
- (4) Explosives that are banned for issue, of a condition other than A, or are otherwise considered unserviceable are to be suitably marked or labelled and segregated from serviceable stock.
- (5) Sufficient space should be left between doorways and stacks of explosives so as to protect the stacks from rain etc.
- (6) Explosives in any stack are to be arranged so that they can be readily identified.
- (7) Gangways should be wide enough to permit easy extraction of single packages or pallets, using MHE if necessary, and to permit the checking of package markings.
- (8) Battens may be used between tiers of packaged and unpackaged stores to achieve stability and assist in ventilation.

7.2.2 Stacking requirements and heights may vary to suit individual munition requirements, restrictions and/or local conditions, but the heights are not to exceed those given below.

7.3 Operational Explosives

7.3.1 Operational explosives are to be stacked separately from training explosives.

7.4 Use of Stack Cards And Pallet Contents Sheets

7.4.1 Stack Cards and Pallet Contents Sheets are to be used as follows:

- (1) At units without electronic stock control measures (e.g. AMANDA), Stack Cards (MOD Form 957) are to be placed on/attached to each stack of explosives and are to show clearly the contents of the stack. Small stocks of different explosives natures with different lot/batch numbers may be stacked together providing each lot/batch is easily identifiable and the CG mixing rules (see Annex E) are applied. When explosives are stored in the open, these stack cards may be held in the relevant Control Office and should be filed in stack number order.

(2) Pallet Contents Sheets may be employed where appropriate for the purposes of ease of location and positive identification of an items lot filler etc in bulk stacks. These Sheets will be the governing document for constraints and stock checking, etc, and must be accurate and legible.

7.5 Spacing of Explosives From PES Structure

7.5.1 To safeguard against flashover from a lightning strike on a PES, all explosives², with the exception of correctly packaged SAA in HD 1.4 (where that is the only explosives within the facility), are to be spaced from the PES structure (including any support pillars) as follows:

- (1) The default separation between the outer face of any explosive package including those stored on racks or trolleys and the inner face of any adjacent structure, support pillars or from metallic fittings such as heaters and luminaries should normally be at least 500 mm. As well as providing protection against flashover, this distance allows good natural airflow around stacks and good access for visual inspection, etc. There is, in addition, to be sufficient distance between the top of the stack and the ceiling to permit easy removal of the ammunition containers.
- (2) When explosives are packaged in containers larger than the standard NATO pallet and it is impractical to observe the standard 500 mm separation distance, then a lesser separation may be used after consultation with the owner of the stocks, the appropriate IE, and if necessary CIE(MOD). In this instance, the separation between the explosives filling of the store concerned and the building structure/metal fittings should be 500 mm.
- (3) Where non-fragmenting demolition explosives are stored in bays and where the separating walls do not extend to the roof of the PES, the separation between the explosives packages and the building structure/fittings may be less than 500 mm where maintaining such a separation would be impractical.
- (4) Under no circumstances must the separation distance be less than 150 mm. Where the separation is less than 500 mm, the storage arrangements should be periodically reviewed with the aim of re-establishing the standard 500 mm separation distance.
- (5) It may be necessary to increase the separation between stacks/packages of explosives where these explosives are considered unusually sensitive to the effects of flashover from a lightning strike or where a particular structure is considered susceptible to such effects. DOSR will provide, through the responsible IE, advice on appropriate measures. In the absence of any such information, the distances at sub-*paras* above, are to be applied.
- (6) The clearance distance of 500mm (and 150mm) as the default separation distance between the outer package and inner face of any adjacent structure or support pillars, required to provide protection from flashover is not applicable to lockers that are licensed as Authorised Quantities.

² Including explosives stored on racking or trolleys.

7.6 Stacking of Loose Packaged (Unpalletised) Explosives

7.6.1 Wherever possible, packages containing explosives should be palletised for ease of handling and transportation and to comply with the Manual Handling Operations Regulations.

7.6.2 A maximum stacking height of 3.7 m is permissible for packaged explosives, with the following exceptions:

Packages containing detonators in CG 'B' – maximum height 1.5 m.

Cylinders:

Under 27 kg	– 7 tiers.
27kg to 45 kg	– 5 tiers
Over 45 kg	– single stack

7.6.3 Packages must be stacked to their lowest profile and placed flat on the stack and not on a side, end or corner first. Stacks of loose packages must be kept to their lowest profile e.g. two low stacks as opposed to one tall stack.

7.6.4 Loose packages should, as far as possible, be stacked in such a manner as to permit free circulation of air around each package.

7.6.5 Loose packages are to be placed on battens so that the stack/package is raised from the floor by 100mm. Battens or fork lift tine slots forming an integral part of the package may be considered as battening provided they allow the free circulation of air.

7.6.6 All stacks are to be stable, with particular attention being paid to corners.

7.6.7 An unobstructed gangway should be left between stacks.

7.6.8 Loose packages may be stowed on pallets un-banded while at ground level. However, they are to be tape banded for movement or stacking.

7.7 Unpackaged Explosives

7.7.1 Explosive stores that are usually packaged are not to be stored in a loose condition unless there is a specific unpackaged DOSR Approval for storage.

7.7.2 Subject to the nature and condition of the floor or the ground and the stability of the stacks, unpackaged explosives may be stacked to a maximum height of 3 m, or that height specified by the safe system of work or munition restriction. Examples are:

- (1) The stacking height of aircraft HE bombs and aircraft rockets is not normally to exceed 1.5 m to ensure stability.
- (2) Unpackaged aircraft cluster bombs are not to be stacked more than one tier high.

7.7.3 The following stacking methods and detail are applicable to unpackaged explosives:

- (1) Vertically (except for cluster bombs) resting on transit bases, provided that adequate stability of the store is afforded.

- (2) Horizontally, cradle stacked in tiers, with the bottom tier secured with wooden wedges and raised off the floor on battens. Tiers of Unboxed Shell are to be arranged head to base to prevent damage to driving bands. Battens may be interspersed between tiers if this will aid stability.
- (3) Adjacent rows of HE aircraft bombs are to be stacked nose to nose or tail to tail.
- (4) Stores are to be so arranged in stacks to ensure that no weight bears on their suspension lugs or other protruding portions.

7.7.4 Unboxed shell are normally to be stored on their bases on wooden dunnage except those incorporating copper base plates which are to be stored horizontally, e.g. Shell BL 155 mm Gun HE. When lack of storage space or local conditions make it necessary to stack all shell horizontally they are to be arranged as follows:

- (1) The bottom tier is to be placed on battens of sufficient thickness to prevent driving bands from coming into contact with the floor.
- (2) Tiers are to be arranged head to tail or where this cannot be done battens are to be placed between each tier.
- (3) Battens are always to be used between tiers of shell of a calibre of 175 mm and above.
- (4) Wooden scotches are to be fixed securely to the battens to hold end shell in the bottom tier and wedges should be inserted between the shell in the bottom tier to prevent any movement. Where battens are used between tiers scotches are to be fixed to the battens to secure end shell.
- (5) The numbers of tiers of loose shell to be stacked are not to exceed:
 - (a) Shell below 140 mm - 15.
 - (b) Shell 140 mm and below 175 mm - 11.
 - (c) Shell 175 mm and below 300 mm - 8.
 - (d) Shell 300 mm and above - 5.

7.7.5 Unboxed shells do not have all the markings required to identify them or the hazard they represent. When unboxed shells are stored a placard is to be placed on or immediately adjacent to the stack. This placard, which is in addition to any placarding of buildings or storage areas required for fire-fighting purposes, is to show the following detail:

- (1) The appropriate Hazard Classification Code label.
- (2) The United Nations Serial Number.
- (3) The BKL.

7.8 Palletised Stores

7.8.1 They should be palletised in accordance with their relevant Unit Load Specification.

7.8.2 Stacking heights for palletised explosives are, in the first instance, determined by the floor design loadings, but are otherwise to be limited to:

- (1) A maximum of 3.7 m for pallets with battens on the underside which result in point loading of the contents of the lowest pallet.
- (2) A maximum of 5 m for pallets with a flat underside that distribute the weight evenly on the pallet contents below it.
- (3) The height permitted by the stability of the stack when the pallets are fitted with support posts that take the weight instead of imposing a load on the contents of the pallets below.
- (4) Only pallets with complete horizontal layers should be stacked as base and intermediate units/
- (5) The height permitted by the PT in the relevant item publication.
- (6) Fraction pallets should only be stacked on top of complete pallets. Where packages overhang their pallet base, they are to be secured by approved tape banding.

NOTE:

ULS No 245 may be stacked six pallets high.
ULS of Detonators in CG B are not to be stacked.
Thin skinned natures in CG H are not to be stacked.

7.8.3 Under no circumstances can part or fraction pallets have voids filled with empty packages to produce an even top tier.

8 SPECIFIC METHODS OF STACKING

8.1 Self-Propulsive Missiles

8.1.1 Certain unpackaged missiles are to be stored only on the special racking provided, on their special-to-type trolleys, or on approved transporters.

8.2 Unboxed Shell

8.2.1 When handling unboxed shell, ensure grommets are not displaced and driving bands, or ballistic caps are not damaged.

8.2.2 The forward end of one shell must not strike the base of another.

8.2.3 Unboxed shells are to be stacked as detailed in para 7.7.4 (5).

8.3 Aircraft Bombs

8.3.1 When handling aircraft bombs, care is to be exercised to ensure that the tails, vanes, identification plates, suspension, and/or lifting lugs are not damaged or distorted. Aircraft bombs must not be stored, moved or handled with the nose of one bomb pointing towards the base of the other.

8.4 Multiple Launch Rocket System (MLRS)

8.4.1 There are various Multiple Launch Rocket System (MLRS) munitions currently in service, including Reduced Range Practice Rockets (RRPR) and Tactical rockets GMLRS M31 and Anti Tank Mine AT2. Detailed handling instructions for live Rocket Pod Containers (RPC's) are available from DM

8.4.2 These contain large quantities of explosives but only the Tactical contain warheads with a High Explosive (HE) filling or content. Although the missile system requires no maintenance, experience shows that the Rocket Pod Container (RPC) is vulnerable to damage caused by mishandling. The following deals with the special requirements associated with the storage and handling of the RPC by Mechanical Handling Equipment (MHE).

8.4.3 At unit level RPC are not to be stacked more than two high without advice from the Technical Explosives Authority.

8.4.4 Under no circumstances are the shock absorbing rubber skids to be removed without the permission of the Technical Explosives Authority unless immediately prior to loading into the launcher.

8.4.5 When storing RPC in field conditions, care must be taken to ensure that no stones, rocks etc protrude into the bottom of the launch tubes or the ignition cabling.

8.4.6 All handling of MLRS RPC is to be carried out using MHE that has a minimum lift capability of 6000 lbs (2721kg). Only one RPC is to be lifted at any one time.

8.4.7 MHE operators handling RPC are to have an observer to ensure that the MHE forks are level and are correctly positioned in line with the markings on the pod prior to moving under the RPC. The forks are to be passed fully under the RPC to prevent damage to the underside of the launch tubes.

8.4.8 A crane may be used, with suitable slings, to handle the RPC. However, only the four lifting hooks at the top of each corner of the RPC may be used as lifting points.

8.4.9 In depots MLRS may be stacked four tiers high. However, the shock absorber (rubber) skids of an RPC will not adequately support a stack of more than two containers. Dunnage is required to be fitted between RPCs in a stack.

8.4.10 A Pod Support Dunnage Assembly is to be constructed from 100 mm x 100 mm x 1050 mm and 25 mm x 100 mm x 1050 mm timber nailed together to form a laminate see Fig 1. Up to six Pod Support Dunnage Assemblies are to be fitted directly behind the skids of the RPCs in a stack see Fig 1. Dunnage is not required under the top RPC in a stack. For stability, the skids of a RPC must be in contact with, and supported by, the rails of the lower RPC. The thickness of the Assembly may need adjusting to achieve this stability. Plywood may be used to adjust the thickness of the Assembly.

8.4.11 Normal floor dunnage is not to be used with MLRS RPCs.

8.4.12 The height of the package guard on some MHE may not permit the placing of the upper RPC on the stack. In this instance the two upper containers may be handled in one lift. Only MHE of sufficient capacity is to be used when lifting two RPCs as one lift.

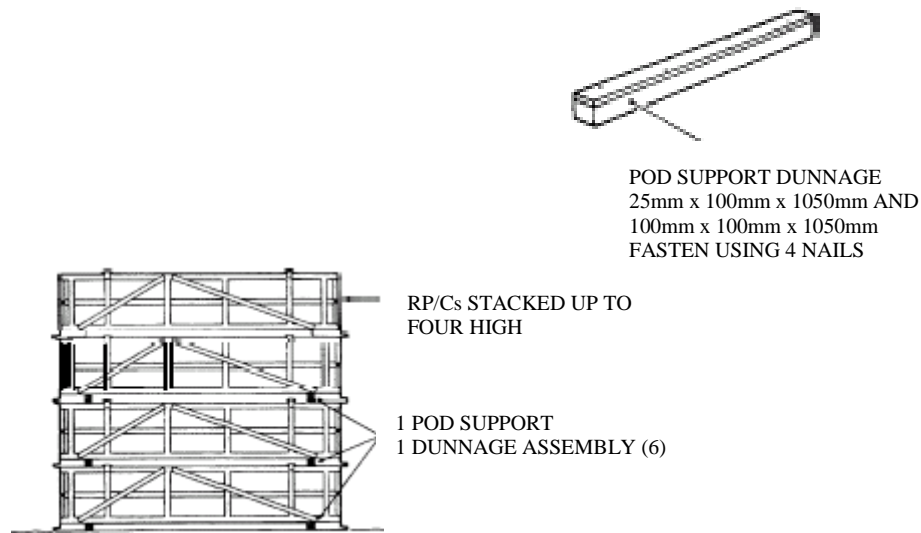

Fig 1: MLRS Dunnage Manufacture and Method of Fitting in the Stack

8.5 White Phosphorus (CG 'H') Explosives

8.5.1 All personnel when working with explosives belonging to CG H are to exercise extreme vigilance to detect any leakage of phosphorus. Detection is easily made by the characteristic smell of phosphorus, which is usually accompanied by the presence of white fumes from leaking ammunition or containers. A phosphorus leak will inevitably inflame and could cause a spread of fire to adjacent explosives. In temperate climates, the packages / ULS are to be inspected externally at intervals of not more than seven days and a record of these inspections is to be maintained.

8.5.2 Packages containing explosives items in CG 'H' may be loose stacked or palletised subject to the following limitations:

- (1) Pallets containing thick-skinned natures may be stacked three tiers high. Thin-skinned natures are to be stacked one tier high only. Loose packages may be stacked up to 1.5m in height.
- (2) Pallets are to be arranged in rows no more than two pallets wide with a 100mm gap between each row and gangways between each set of rows.
- (3) Packages should be placed on pallets so that there is immediate MHE access to each package or pallet to allow prompt removal of any leaking package. The maximum number of pallets to be moved to afford access to a leaking package is not to exceed eight.

8.5.3 The following items are to be provided in, or at, the building or compartment in which explosives belonging to CG H is stored:

- (1) A container filled with water large enough to completely immerse the largest ammunition container holding explosives of CG H.
- (2) A container of clean water or bottles of sterile water together with gauze and a selection of large dressings for First Aid use. Containers of water are to be cleaned and refilled weekly.
- (3) A suitable tool to cut Tensile Steel Strapping (TSS) in the case of palletised explosives.
- (4) Goggles or eyeshields.

- (5) Protective apron.
- (6) Elbow length fire retardant gauntlets.
- (7) Lifting tool or apparatus.
- (8) Fire retardant head protective wear.
- (9) Eyewash equipment.

8.5.4 Stores containing White phosphorus should be stored under the coolest conditions available and should not be exposed to direct or indirect sunlight, as heat increases the likelihood of spontaneous ignition. A phosphorus fire is extinguished by drowning in water. In the event of a leaker being discovered action is to be taken to completely immerse the container or item in water.

8.6 Storage of Explosives in Compatibility Group L

8.6.1 Explosives belonging to CG L require special storage conditions depending on the nature of explosives. The conditions of storage will be advised by the Technical Explosives Authority and are to be included in Unit Standing Orders.

8.7 Ammunition Containing Depleted Uranium

8.7.1 Depleted Uranium (DU) is mildly radioactive at a level that is low enough to permit handling and transportation with simple precautionary measures. DU has a chemical toxicity at the same level as other heavy metals such as Lead, allowing handling and transportation in authorised packaging without abnormal risk. The mechanisms whereby radioactivity and toxicity might lead to harmful effects are if:

- (1) Personnel are in close contact with DU over extended periods,
- or
- (2) If DU is involved in a fire or explosion in which Uranium Oxides from the ammunition could be dispersed and inhaled by personnel sited downwind from the event.

8.7.2 Advice on storage of ammunition containing DU is to be sought from the appropriate IE. Handling and transportation of DU ammunition is to be kept to a minimum and no work or movement is to be carried out without prior reference to a Radiological Protection Supervisor. General regulations for the transportation of DU ammunition are in this document and ESTC Guidance Note No 1, and contingency planning for accidents and incidents is detailed in ESTC Guidance Note No 5. Copies of these publications should be held where ammunition containing DU is stored and transported.

9 USE OF RACKING

9.1 General

9.1.1 Stacking heights may be increased by the use of racking of sufficient load bearing capacity. However, the floor design loadings may be limiting, and due regard is to be given to overreach in stacking and the additional risk involved should a package be dropped from the top of the racking. The racking should be of a non-flammable or fire-retardant material whenever possible.

9.2 CG 'H'

9.2.1 Loose packages containing CG 'H' may be stored on racking provided that they are not more than 1.5 m from the floor and they are easily accessible to allow prompt removal in the event of leakage.

10 STACKING OF LOADS USING MECHANICAL HANDLING EQUIPMENT

10.1 Specifications for Mechanical Handling Equipment

10.1.1 Only mechanically operated moving, lifting and stacking equipment that conforms to the constructional specifications and limitations specified are permitted in explosives facilities.

10.1.2 Special to type containers with facilities for lifting by Mechanical Handling Equipment (MHE) should be moved using the approved method.

10.1.3 All MHE is to be correctly maintained in accordance with instructions issued by the Engineering Authority and the equipment is not to be used if it has any defect liable to affect its safe running.

10.2 Movement of Palletised Loads Using Mechanical Handling Equipment

10.2.1 Before any assembled unit load is moved or handled, the tensile steel strapping is to be checked for obvious slackness or damage. Should slackness or damage be noted, the unit load must be re-banded.

10.2.2 Under normal operating conditions, all unit loads should be lifted singly. Two units may be lifted simultaneously provided that the Explosives Safety Representative satisfies himself that there is no other approved means of positioning the load and that he completes a written Risk Assessment which must include/ensure the following:

- (1) Loads being moved must be sound, properly tape banded and produce a stable load.
- (2) The capacity rating of the MHE is not exceeded.
- (3) The floor is level and free from irregularities.
- (4) Forward tilt of the MHE is not used.
- (5) The driver's vision is unrestricted, and the greatest care exercised if there are overhead obstructions (e.g. roof trusses, pipes etc).
- (6) The MHE is fitted with a carriage back guard of adequate size to prevent the upper unit load to slide off the lower when full backward tilt is used.
- (7) The duration and distance travelled, and the height lifted is to be kept to the minimum necessary.
- (8) The operation is to be closely supervised.

10.2.3 Where the operation is being carried out during loading and unloading of Lighters and RFAs the additional requirements must be met:

- (1) Consideration must be taken of the pitch/roll of the ship/Lighter and the deck surfaces.
- (2) The total overall height of the stacked loads must be kept to a minimum and must not exceed 2.2 m.
- (3) Stacked loads must not be lifted for further stacking on other loads.

10.2.4 The preferred method of moving loads while stacked is by Fork Lift Truck with the load fully supported and positioned against the heel of the forks with no forward tilt being applied. Pedestrian operated pallet-trucks may be used, but require greater operator control during movement.

10.3 Use Of Lifting/Slinging Gear With Explosives

10.3.1 Explosives may only be lifted/slung in their approved containers using approved lifting/slinging methods and equipment as detailed in their safe system of work and that has been subjected to a physical “before use” inspection and is fully serviceable and within test date.

10.3.2 Pallets fitted with designed and recognised lifting points may be lifted with the approved slinging gear without using anti-spilling devices such as nets or trays. Such lifts must refer to the slinging method detailed in the safe system of work. Slinging of loads in NATO Standard pallets is to be by reeving the slings through the blocks on the pallet base - slinging by using the pallet wings is not permitted.

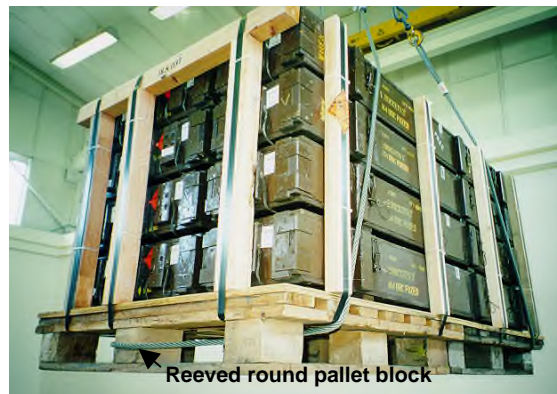

10.4 Ferrous Slings

10.4.1 Because of the danger from sparks, ferrous lifting chains, wire rope slings, strops or any rope slings fitted with ferrous hooks are only to be used for handling items in Category C or D PES.

10.4.2 If, exceptionally, ferrous slings are specified for use in PES of other Categories, such slings are to be used only to handle the items to and from the working positions and are to be removed from the room before any explosives are exposed.

10.5 Multi-Legged Slings

10.5.1 Multi-legged sling assemblies are normally only to be used with all legs attached. Where it is essential to use the single leg of a multi-legged sling to lift a load, the load lifted is never to exceed the $0 - 45^\circ$ ($0 - 90^\circ$ included angle between opposite legs of a 4 leg sling) working load limit (WLL) identified on the sling divided by 2.1.

10.6 Slinging of Loads

10.6.1 Loads must only be lifted the minimum height necessary to clear obstructions and for the minimum duration. When lifting or lowering loads a clear working space is essential around the lifting/lowering point.

10.6.2 Loads should not be slung over other explosives. Spigot like projections/protrusions such as stanchions should be removed from under the path of the explosives being slung or suitable mats placed over projections/protrusions.

10.6.3 When hoisting slings/strops clear from a load, it is essential that all slings/strops, once released, are held clear of the container or load until hoisted to avoid the possibility of the slings/ strops snagging on that load.

11 UNDERGROUND STORAGE AREAS

11.1 Introduction

11.1.1 The regulations contained in these paragraphs are particular to the administration and operation of underground storage areas and are additional to those contained in the preceding paragraphs, which are also to be observed where applicable.

11.2 Stacking

11.2.1 Stacking is to follow normal above ground practice. Stacks are to be kept clear of access routes (such as roads or railways).

11.2.2 Stacks of packages are to be carefully and regularly monitored for signs of deterioration. Deterioration in the bottom tiers may lead to the collapse of a stack with consequent damage to the contents, fire or other event, though stacking trials should result in a restriction in stacking height to preclude such an event. Stacking heights and methods should be in accordance with approved procedures and to heights authorised by the appropriate PT following such stacking trials.

11.3 Repair and Maintenance

11.3.1 Repair and maintenance of underground facilities is to be in accordance with the general instructions in this document. Work between the lining walls and the surface of the excavation is to be controlled in accordance with the Work in Confined Spaces Regulations.

11.4 Records

11.4.1 All records of stocks held in an underground storage area and their location, together with records of the temperature and humidity readings, roof or wall defects, examinations made, maintenance work done, etc, are to be kept outside the underground site in a place not likely to be involved or destroyed in a major fire or explosion.

11.5 Prohibited Storage

11.5.1 The following explosives are not to be stored in underground sites:

- (1) Enemy stocks.
- (2) Items returned by units that are awaiting inspection.
- (3) Items in, or suspected to be in, doubtful or unsafe condition.
- (4) Items not classified by DOSR or not of an approved pattern.

11.6 Limitations in Underground Storage

11.6.1 The following explosives natures are only permitted in single chamber storage sites with complete segregation by nature:

- (1) Those with incendiary or smoke effects belonging to CG 'H' (white phosphorus) and some of CG 'G', because of the loss of visibility when smoke is trapped underground.
- (2) Those in CG 'J', due to the risk of an explosive atmosphere posed by any leak.
- (3) Those in CG 'K' due to the difficulty in decontamination.
- (4) CG 'L' is to be isolated.

11.7 Fire Precautions

11.7.1 Special fire fighting considerations apply in underground storage sites.

11.8 Mechanical Handling Equipment

11.8.1 It should be noted that there is an increased hazard in an underground site caused by the accumulation of exhaust fumes.

11.9 Humidity

11.9.1 High humidity, such as that often found in underground sites, has an adverse effect on many materials. Humidity is therefore to be controlled by ventilation or approved air conditioning. Where temperature control is not a prime consideration, an approved de-humidifying system may be used which limits RH to 80%.

11.10 Non-Explosive Dangerous Goods

11.10.1 Non-explosive Dangerous Goods are not to be stored in underground explosives facilities.

Intentional Blank Page

CHAPTER 13**ANNEX A****APPROVAL TO STORE AND HANDLE EXPLOSIVES****CONTENTS**

Paragraph

1 APPROVAL TO STORE AND HANDLE EXPLOSIVES

1.1 DE&S Storage

1 APPROVAL TO STORE AND HANDLE EXPLOSIVES

1.1 DE&S Storage

1.1.1 With certain exceptions granted by IE(DE&S), service and commercial explosives stores to be stored and handled by DE&S Defence Munitions (DM) are subject to a prior to acceptance for storage and handling formal approval procedure, known as the 'Approval to Store and Handle Explosives' (ASHE). ASHE approval is also required for explosives stores passing through DM Explosives Sites for other destinations e.g. to be embarked on HM Ships, Royal Fleet Auxiliaries (RFA's) or commercial ships. ASHE also includes the Replenishment in Harbour of HM Ships, submarines and RFA's. The acceptance of stores into DM Explosives Sites is conditional on ASHE clearance being in place prior to its receipt.

1.1.2 The ASHE process gives DM complete and comprehensive assurance that explosive items being taken into DM custody or which will be handled by DM meet the following:

- (1) They have the appropriate MOD and legal explosive safety clearances.
- (2) That their storage/handling constraints and in store maintenance requirements are clearly defined, are achievable and are documented.
- (3) That their package/palletisation configuration ensures safe storage, handling, internal transport and Replenishment in Harbour and are compatible with DM storage and handling systems and procedures.
- (4) That acceptable and properly documented safe systems of work covering their storage, handling, internal transport and Replenishment in Harbour are in place. The DM Departmental safe system of work is contained in the munition specific Storage and Handling Instruction for Munitions (SHIM).
- (5) That staff have been trained in the procedures involved in the above.

1.1.3 The ASHE process gives a DM Explosives Site approval to store and handle a specific explosive store. DM certify that they will not accept items into their Establishment which have not been cleared for receipt into their Establishment and that they will not issue items to other DM Establishments not having ASHE approval to accept that item.

1.1.4 Where no ASHE certification exists an items introduction into service may be jeopardised as it is likely to be refused entry to a DM Explosives Site, be left on the delivery vehicle, or placed in isolated storage pending confirmation of its clearance status and that it is covered by a DM safe system of work. DM considerations are the legal and regulatory liability of handling, storing and transporting items which may not have legal and appropriate clearances or are not covered by a safe system of work.

1.1.5 The ASHE system does not include explosives processing which is covered by the Approval to Process (ATP) system.

1.1.6 Detailed operating procedures for the ASHE system are available on the DM Def Net site.

CHAPTER 13**ANNEX B****CALCULATION OF STORAGE CAPACITY AND SPACE REQUIREMENT****CONTENTS**

Paragraph

1 CALCULATING

1.1 Ultimate Maximum Storage Capacity

1.2 Calculating Space Requirements

1.3 Palletised Stores

1 CALCULATING**1.1 Ultimate Maximum Storage Capacity**

1.1.1 The limiting factors to be considered when calculating the quantity of explosives that a building will accommodate are:

- (1) The limit imposed by the effective capacity of the building.
- (2) The maximum NEQ by Hazard Division for which the building is licensable.

1.1.2 The ultimate maximum capacity of a building is the smaller of the two figures calculated.

1.2 Calculating Space Requirements

1.2.1 The calculation of space requirements is as follows:

(1) Floor Area - Packaged Stores. The floor area in square metres that will be occupied by a given quantity of packages can be determined from the formula:

$$\text{Area} = \frac{m \times w \times L}{N}$$

where:

m = total number of packages; n = number of tiers of packages; w = width of the package in metres and L = length of package in metres.

(2) Floor Area - Unpackaged Stores. The floor area in square metres that will be occupied by a given quantity of unpackaged stores can be determined from the formula:

$$\text{Area} = \frac{2m + n^2 - n}{2n} \times dL$$

where:

m = total number of stores to be stacked; n = number of tiers; d = overall diameter of the store in metres and L = its overall length in metres.

(3) Number of Tiers. The number of tiers of unpackaged stores that will not exceed the permitted stacking height can be determined from the formula:

$$\text{No of Tiers} = \frac{h - d}{d \times 0.865} + 1$$

where:

h = maximum permitted stacking height in metres; d = overall diameter of store in metres. Allowance should also be made for battens, if used.

1.3 Palletised Stores

1.3.1 For planning purposes, storage space for palletised stores is to be calculated in Units of Space (UoS). Each UoS equates to a standard Unit Load of a maximum size of 1080 x 1300 x 1372 mm (i.e. 1.93 m³), subject to a maximum floor loading of 16 000 lbs (7257 kg) for a single stack pallet base area.

CHAPTER 13**ANNEX C****HAZARD DIVISIONS****CONTENTS**

Paragraph

1 HAZARD DIVISIONS

- 1.1 Introduction
- 1.2 Hazard Divisions 1.1
- 1.3 Hazard Divisions 1.2
- 1.4 Hazard Divisions 1.3
- 1.5 Hazard Divisions 1.4
- 1.6 Hazard Divisions 1.5
- 1.7 Hazard Divisions 1.6

1 HAZARD DIVISIONS**1.1 Introduction**

1.1.1 Class 1 is divided into six Hazard Divisions according to the hazards presented in the event of an initiation. The initial figure refers to the Class of Dangerous Goods (i.e. Class 1 - Explosives); the second figure refers to the hazard. The respective definition of each is as follows:

1.2 Hazard Division 1.1

1.2.1 HD 1.1 comprises substances and articles that:

- (1) Have a mass explosive hazard.
- (2) Have major hazards of blast, high velocity projections and other projections of low velocity.
- (3) If exploded, will result in severe structural damage, the severity and range being determined by the amount of explosive involved and the distance from the explosion site. There may be a risk from heavy debris propelled from the structure in which the explosion occurs, or from the crater.
- (4) May display hazards associated with other HD.

1.3 Hazard Division 1.2

1.3.1 HD 1.2 comprises substances and articles that:

- (1) Have a projection hazard but not a mass explosion hazard.
- (2) If exploded, results in items burning and exploding progressively, a few at a time. Furthermore, fragments, firebrands and unexploded items may be projected in considerable numbers; some of these may explode on impact and cause fires or explosions. Blast effects are limited to the immediate vicinity.

(3) HD 1.2 is further subdivided into three categories. For the purpose of determining Quantity Distances (QD), i.e. for storage only, a distinction is made between those items which give small fragments of moderate range and those items which give large fragments with a considerable range. The third category is a special division for insensitive munitions. These are described as follows:

(a) SsD 1.2.1 contains the more hazardous items of HD 1.2 with an individual HE content of 0.73Kg or above, which give large fragments over an extended range.

(b) SsD 1.2.2 contains the less hazardous items of HD 1.2 with an individual HE content of less than 0.73Kg, which give smaller fragments of limited range.

(c) SsD 1.2.3, is defined as munitions which, in their designated package, do not exhibit propagation in the equivalent of a UN Series 6 b test (STANAG 4396) and bullet impact (STANAG 4241) and only burns in an external fire UN Series 6c test (STANAG 4240), and slow heating (STANAG 4382) tests. These munitions have their own set of QDs (see ESTC Standard 15) unique to the munition and facility and such munitions must be qualified as Insensitive Munitions (IM) by the Insensitive Munitions Assessment Panel (IMAP).

1.4 Hazard Division 1.3

1.4.1 HD 1.3 comprises substances and articles that :

(1) Have a fire hazard and either a minor blast hazard or a minor projection hazard or both, but not a mass explosion hazard.

(2) Burn with great violence, and intense heat, emitting considerable thermal radiation (mass fire hazard), or burn sporadically. Items in this division may explode but do not usually form dangerous high velocity fragments. However, firebrands and burning containers may be projected.

(3) For the purposes of determining QD (i.e. for storage only), a distinction has been made as follows between those items which have a mass fire risk and those items which only burn sporadically:

(a) SsD 1.3.3: contains the more hazardous items with mass fire hazard and considerable thermal radiation.

(b) SsD 1.3.4: contains the less hazardous items that burn sporadically.

1.5 Hazard Division 1.4

1.5.1 HD 1.4 comprises substances and articles that:

(1) Are primarily a moderate fire hazard.

(2) Do not contribute excessively to a fire. The effects are largely confined to the package unless the package becomes degraded due to the effects of the fire. No fragments of appreciable size or range are to be expected. An external fire does not cause the simultaneous explosion of the total contents of a package of such items.

(3) Some, but not all, of HD 1.4, are in Compatibility Group 'S'. 1.4S items are so designed or packaged such that any hazardous effects arising from accidental functioning are confined within the package unless the package has been degraded by fire. In this case all blast or projection effects are limited to the extent that they do not

significantly hinder fire-fighting or other emergency response efforts in the immediate vicinity, i.e. within 5 m of the packages.

1.6 Hazard Division 1.5

1.6.1 HD 1.5 comprises explosive substances that have a mass explosion hazard but are so insensitive that there is very little probability of initiation or of transition from burning to detonation under normal conditions of transport. The probability of transition from burning to detonation is greater when large bulk quantities are transported or stored. For the purposes of determining QD, explosives of HD 1.5 are deemed to belong to HD 1.1.

1.7 Hazard Division 1.6

1.7.1 HD 1.6 comprises extremely insensitive articles that do not have a mass explosion hazard. HD 1.6 includes those articles which contain only extremely insensitive detonating substances and which demonstrate a negligible probability of accidental initiation or propagation as assessed at Test 7 of AASTP-3. The risk from articles of HD 1.6 is limited to the explosion of a single article.

Intentional Blank Page

CHAPTER 13**ANNEX D****COMPATIBILITY GROUPS**

See NOTES:

Description of Substance or Article to be Classified	Compatibility Group
(a)	(b)
Primary explosive substance.	A
Article containing a primary explosive substance and not containing two or more effective protective features.	B
Propellant explosive substance or other deflagrating explosive substance or article containing such explosive substance.	C
Secondary detonating explosive substance or black powder or article containing a secondary detonating explosive substance, in each case without means of initiation and without a propelling charge, or article containing a primary explosive substance and containing two or more effective protective features.	D
Article containing a secondary detonating explosive substance without means of initiation with a propelling charge (other than one containing a flammable or hypergolic liquid).	E
Article containing a secondary detonating explosive substance with its own means of initiation, with a propelling charge (other than one containing a flammable or hypergolic liquid) or without a propelling charge.	F
Pyrotechnic substance, or article containing a pyrotechnic substance, or article containing both an explosive substance and an illuminating, incendiary, lachrymatory or smoke-producing substance (other than a water-activated article or one containing white phosphorus, phosphide or a flammable liquid or gel).	G
Article containing both an explosive substance and white phosphorus.	H
Article containing both an explosive substance and a flammable liquid or gel.	J
Article containing both an explosive substance and a toxic chemical agent.	K
Explosive substance or article containing an explosive substance and presenting a special risk needing isolation of each type.	L
Article containing only extremely insensitive detonating substances.	N
Substance or article so packed or designed that any hazardous effects arising from accidental functioning are confined within the package unless the package has been degraded by fire. In this case all blast or projection effects are limited to the extent that they do not significantly hinder or prohibit fire fighting or other emergency response efforts in the immediate vicinity of the package.	S

NOTES:

(1) Attention is drawn to the descriptions of CGs B, F, D and E. The essential differences between them are subtle and depend on such things as:

- (a) Whether a means of initiation is or is not fitted.
- (b) Whether the means of initiation has at least two effective protective measures that prevent the initiation of the ammunition in the event of accidental functioning of the means of initiation during handling, storage and transportation.

- (c) Whether the means of initiation is packed in the same package as the ammunition (but separately). The method of packaging is such as to prevent the initiation of the ammunition in the event of an accidental functioning of the initiating device.
- (2) These differences are best illustrated by examples, as follows:
- (a) A detonating fuze will be CG B if it does not have at least two effective protective features, but will be CG D if it does.
- (b) A plugged HE shell or bomb will be CG D.
- (c) An HE shell or bomb fitted with a CG D fuze will be classified as CG D.
- (d) An HE shell or bomb fitted with a CG B fuze will be classified as CG F.
- (e) HE grenades packed with their fuzes will be classified as CG D only if it has been demonstrated that even if the fuzes function accidentally, the grenades will not be initiated; otherwise they will be classified CG F.
- (f) An HE round fitted with a CG D fuze will be CG E but will be CG F if it has a CG B fuze.
- (3) CG D applies only when secondary detonating explosive (High Explosives) substances, or Black Powder, are properly packaged in an approved dust-tight container. Otherwise CG L applies.

CHAPTER 13

ANNEX E

MIXING OF COMPATIBILITY GROUPS IN ABOVE GROUND STORAGE

CONTENTS

Paragraph

1 MIXING OF COMPATIBILITY GROUPS IN ABOVE GROUND STORAGE

1.1 Mixing Rules for Compatibility Groups

1.2 HD 1.4

1.3 CG H

1.4 Underground Storage

Table

1 Compatibility Group Mixing Rules for Storage

1 MIXING OF COMPATIBILITY GROUPS IN ABOVE GROUND STORAGE

1.1 Mixing Rules for Compatibility Groups

1.1.1 Table 1 and accompanying notes detail the permitted mixing of Compatibility Groups (CGs) for HD 1.1 - HD 1.4. Currently, there are no military explosives of HD 1.5 or HD 1.6, and further information regarding storage of these HDs is to be obtained from DOSR through the appropriate IE. Unrestricted mixing in storage, where permitted, is shown by a black square. Further mixing aspects are prescribed in the accompanying notes. There may be special circumstances where the mixing rules below could be modified by DOSR subject to adequate technical justification based on tests when these are considered to be appropriate. Further information may be obtained from DOSR through the appropriate IE.

TABLE 1 COMPATIBILITY GROUP MIXING RULES FOR STORAGE													
CG	A	B	C	D	E	F	G	H	J	K	L	S	N
A													
B			Note 1	Note 1	Note 1	Note 1	Note 1						
C		Note 1				Note 2	Note 3						Note 5
D		Note 1				Note 2	Note 3						Note 5
E		Note 1				Note 2	Note 3						Note 5
F		Note 1	Note 2	Note 2	Note 2		Note 2&3						
G		Note 1	Note 3	Note 3	Note 3	Note 2&3							
H													
J													
K													
L											Note 4		
S													
N			Note 5	Note 5	Note 5								

NOTES:

(1) Articles of CG B are to be segregated in storage from other articles of CGs C, D, E, F and G by means which are effective in the prevention of propagation to those other articles, i.e. in a separate compartment, or by use of suitable traverses/barriers or simple distance separation. Fuzes of CG B may be stored with their parent explosive articles, but the NEQ must be aggregated and the whole treated as CG F.

(2) Articles of CG F are to be segregated in storage from other articles of other CG by a means that is effective in the prevention of propagation of those other articles, i.e. in a separate compartment or by use of suitable traverses/barriers or simple distance separation.

(3) Articles of CG C, D or E, or those articles of CG G which do not give rise to loose explosives powder, may be mixed in storage. Articles in CG G that may give rise to loose explosives powder will be given special consideration by ESTC through the relevant IE.

(4) Articles of CG L are to be stored separately from all articles of other CG as well as from all other articles of CG L.

(5) Articles of CG N are not normally to be stored with articles of other CGs except S. However, if articles of CG N are stored with articles of CGs C, D and E, the articles of CG N are to be considered as CG D.

1.2 HD 1.4

Articles of HD 1.4 may be mixed in storage with articles of CGs B, C, D, E, F, G, N, or S in all HDs.

1.2.1 Articles of HCC 1.4S may be mixed in storage with substances or articles of CGs B, C, D, E, F, G, H, J, N, or S in all HDs.

1.3 1.3 CG H

1.3.1 Additional storage and safety requirements for CG H are contained in Chapter 13 and Chapter 17.

1.4 Underground Storage

1.4.1 Further limitations are detailed in Chapter 13 at para 11.6.

CHAPTER 13**ANNEX F****STORAGE OF EXPLOSIVES ORDNANCE DISPOSAL ARISING****CONTENTS**

Paragraph

- 1 GENERAL
 - 1.1 Introduction
 - 1.2 Exclusions
 - 1.3 Legal Position
 - 1.4 Competent Person
 - 1.5 Terminology
 - 1.6 EOD Operator Action
 - 1.7 EOD Storage
 - 1.8 Transportation of EOD Arisings
- 2 CLASSIFICATION OF EOD ARISING FOR STORAGE AND TRANSPORT
 - 2.1 General
 - 2.2 Disposal Classifications
 - 2.3 Specific Situations
- 3 EOD ARISING - DOCUMENTATION AND RECORDS
 - 3.1 Accounting
 - 3.2 Disposal Classification Documentation for DOSR
 - 3.3 Retention of Documentation
- 4 CONDITIONS FOR THE PACKAGING, STORAGE AND TRANSPORT OF EOD ARISING
 - 4.1 Packaging
 - 4.2 Method of Pack
 - 4.3 Packaging Markings for EOD Arisings
- 5 NATURES OF EOD ARISING
 - 5.1 High Explosive
 - 5.2 Small Arms Ammunition
 - 5.3 Pyrotechnics
 - 5.4 Anti-riot and Chemical Training Items
 - 5.5 White Phosphorus
 - 5.6 Inert
- 6 STANDARDS OF STORAGE FOR EOD ARISING
 - 6.1 Licensing
 - 6.2 Standards of Storage
 - 6.3 Safety Certificate / Disposal Classification Form (MOD Form 1661)
 - 6.4 Time Constraints

7 EOD CHEMICAL MUNITION ARISING

- 7.1 General
- 7.2 Packaging
- 7.3 Transport

Appendix

- 1 Unexploded Ordnance Disposal Classifications List

1 GENERAL

1.1 Introduction

1.1.1 This annex provides regulations for the storage and transport of EOD arisings for the guidance of those involved in planning and arranging the storage and transport of these munitions/explosives. Definitions of Terms for Explosive Ordnance (EO) and EOD are those found in JSP 364 – Joint Service EOD Manual. EOD arisings cover all EO defined in JSP 364. Included are collections from civilian agencies, individuals and amnesties, and all planned area Explosive Ordnance Clearances (EOC). EOD arisings from criminal and terrorist activities are included, but are subject to separate current legal forensic procedures.

1.2 Exclusions

1.2.1 The following arisings are excluded:

- (1) Life expired or surplus items, in their authorised packaging, which are subject to formal demilitarisation and disposal.
- (2) Nuclear weapons.
- (3) Disposals of logistic stock holdings that become unserviceable and in their authorised packaging, except where subject to EOD action.
- (4) The EOD action carried out prior to a move of EO to short term licensed storage is also excluded.

1.3 Legal Position

1.3.1 Legislation covering the classification, labelling, packaging, storage and transport of explosives is drawn up to cover new or serviceable explosives in their authorised packaging. It was never designed to cover EOD operations or EOD arisings, which is why EOD is disapplied in Statutory Instruments (SI). The Secretary of State for Defence has made it clear that the MOD must have systems in place which are equally as good as SIs. This is not possible where the operational and peacetime requirements and EOD arisings are not catered for in the SIs and, moreover, cannot be met. It is therefore necessary to lay down procedures associated with the handling, storage and transportation of EOD arisings that are as safe as practically possible, which need to be approved by a Competent Person.

1.4 Competent Person

1.4.1 In respect of EOD arisings, a Competent Person is a nominated member of the holding/consigning unit. The holder of this post would be competent by virtue of the successful completion of accredited EOD courses, or the award of a trade qualification. In either case, the holder must be an Officer, Warrant Officer or Senior Non-Commissioned Officer or MOD civilian of equivalent rank authorised by the HoE.

1.5 Terminology

1.5.1 The operational phase of any EOD operation commences at the point to which EOD resources deploy. In simplistic terms, the operator will destroy in-situ or move for disposal any EO found.

1.5.2 The operator applies his specialist technical knowledge to carry out an assessment to determine whether the item is safe to move. The completion of the risk assessment for transportation and possible concentration centrally of EOD arisings for later disposal lies with the operator at the time of the EOD operation. The move will be either:

(1) To a more appropriate location for immediate disposal.

Or

(2) When the volume or location of EOD arisings prevents immediate disposal and the operator considers the item safe to transport to a isolated licensed storage location for later disposal.

1.6 EOD Operator Action

1.6.1 The recovery phase of any EOD operation entails the move of EOD arisings from the discovered location to a segregated licensed store. A COSHH assessment should be carried out. All EOD arisings to be moved are to be segregated, packed and marked as the operator deems appropriate for this operational move. The items should be packed in packaging appropriate to the EO nature and which affords sufficient environmental and physical protection. The move must take place in accordance with the DSA03 DLSR Movement and Transport Safety Regulations, Dangerous Goods Manual (DGM).

1.6.2 The planning phase of EOD operations should include the procedures for the disposal of items found. Where EO is not destroyed in-situ during that working week, para 1.6.1, above, applies and the EO is to be moved to short term licensed storage.

1.7 EOD Storage

1.7.1 Recovered EOD arisings held in segregated licensed storage locations cannot be regarded as being in an operational situation. The storage and transportation of these holdings from this point must comply with these regulations in order to control these operations with regard to the safety of life and property.

1.8 Transportation of EOD Arisings

1.8.1 Transportation of EOD arisings is to be in accordance with the DGM.

2 CLASSIFICATION OF EOD ARISINGS FOR STORAGE AND TRANSPORT

2.1 General

2.1.1 The need exists to identify and classify items for storage and the final move from storage to disposal. Problems arise because:

(1) The validity of classification tests originally carried out on the store/package when pristine may not reflect the current status.

(2) Where packaging exists, unserviceable items may have deteriorated or be damaged and cannot be properly classified.

- (3) Some items may be identifiable only by generic type, purpose, estimated NEQ, fuzing and other hazards.
- (4) Other items may not be identifiable other than possibly being EO.

2.2 Disposal Classifications

2.2.3 Where the operator and/or EOD Unit can positively identify the EOD arisings, CIE(MOD) authorises the EOD unit to award a Disposal Classification (DC) from the list at Appendix 1. Where generic identification is not possible, the item is to be awarded a DC of 1.1F.

2.3 Specific Situations

2.3.1 There will be specific situations, such as large scale EOC or large finds, which cannot be dealt with by DC procedures. On these occasions, the operationally responsible unit is to apply to CIE (MOD) for formal Temporary Classification. Before classification is awarded, CIE (MOD) may wish to see the planning procedure from reconnaissance and identification through scale of disposal to final disposal arrangements.

3 EOD ARISINGS - DOCUMENTATION AND RECORDS

3.1 Accounting

3.1.1 All EOD arisings must be accounted for and registers of holdings kept. This is an auditable document and should show the item history from recovery to disposal. Accounting management is to be in accordance with written unit procedures. Once packed, the package should be marked with a unique identifier relating to the contents registered in the accounting system.

3.2 Disposal Classification Documentation for DOSR

3.2.1 As the Competent Authority, DOSR needs to be able to audit the EOD arisings disposal system. Units consign EOD arisings for final disposal using the UXO Storage Safety Certificate / Disposals Classification Form (MOD Form 1661). This form is to be kept as a register to record every item disposed of. DOSR staff are to have access to this register for audit purposes as and when required.

3.3 Retention of Documentation

3.3.1 For records purposes, closed unit records are to be maintained for a minimum of 5 years. UXO Disposals Classification Forms are to be kept for a period of 5 years.

4 CONDITIONS FOR THE PACKAGING, STORAGE AND TRANSPORT OF EOD ARISINGS

4.1 Packaging

4.1.1 The Competent Person is responsible for ensuring that only appropriate containers/restraints are used for storage (for transportation, see the Dangerous Goods Manual (DGM). If available, the correct ammunition container assembly (ACA) and inner packaging fitments are to be utilised. If not available, then only suitable, serviceable ammunition containers are to be used. Empty containers can be demanded from DM Longtown. Where the above requirements cannot be met, DOSR is to be approached for formal Temporary Classification.

4.2 Method of Pack

4.2.1 Ideally, all items should be packed to their Full Standard Service Pack (FSSP). When the correct or original furniture is not available, the container contents are to be secured against movement by use of expanded foam or other inert packing medium. The package net mass limit for contents, specified in the UN Package Certification Mark for the outer container used, is not to be exceeded and each package is to be sealed. Internal separation of stores will be the norm, for which material can be procured locally. To assist with the monitoring of NEQs against explosive limits, recovered items should be segregated and grouped into correctly marked containers.

4.3 Packaging Markings for EOD Arisings

4.3.1 No UN Package Certification Mark need be applied to the outer container. However, all containers are to have the following basic markings applied both in storage and for the subsequent movement to the point of disposal:

- (1) Description. A generic description, or the letters FFE if inert.
- (2) Disposal Classification Code. The correct HCC and subsidiary risk labels are to be affixed.
- (3) United Nations (UN) Serial Number. The UN serial number.
- (4) All Up Weight (AUW). The package AUW in kg.
- (5) Account Reference. The Unit accounting reference of the item or items contained within.
- (6) Estimated NEQ. In kg.

4.3.2 Markings are to be clear and legible, marked onto the container directly or by secure printed adhesive label.

5 NATURES OF EOD ARISINGS

5.1 High Explosive

5.1.1 Any High Explosive item should be further divided into HDs 1.1/1.2/fuzed/unfuzed EO and stored in accordance with the Explosives License.

5.2 Small Arms Ammunition

5.2.1 All Small Arms Ammunition (SAA) should be held segregated by weight and packaged by type. Pinfire and SAA of 0.50 in calibre and above are to be stored separately. SAA is to be sorted as follows:

- (1) SAA.
- (2) Shot gun (all shot types, less CS).

5.3 Pyrotechnics

5.3.1 Recovered pyrotechnics should be packaged generically by type. Any safety mechanism such as lanyards or pins are to be correctly fitted and, if necessary, secured by the application of suitable adhesive tape. Fireworks are to be packed in such a way as to

preclude the escape of loose powder or filling from the container, i.e. sift-proof. Pyrotechnics should be grouped for storage and subsequent disposal as follows:

- (1) 1.2G: Rockets, Rockets Hand Fired, Line Throwing Apparatus.
- (2) 1.3G: Distress Flares, Hand Flares.
- (3) 1.4G: Distress Flares, Hand Flares.
- (4) 1.4G: Smoke natures.

5.4 Anti-riot and Chemical Training Items

5.4.1 Only lachrymatory and anti-riot (AR) control agents may be held and these are to be identified as those with or without explosive components. Where possible, CS natures should be packed or retained in their FSSP. Non-explosive natures are to be packed separately and marked accordingly. All natures must be packed in grey ammunition containers complete with subsidiary risk labels. Any munitions containing chemical agents (CG 'K') should be moved direct to DSTL Porton Down for disposal in accordance with para 7 using packaging either supplied by, or recommended by, DSTL.

5.5 White Phosphorus

5.5.1 If White Phosphorus (WP) munitions have to be recovered, current regulations covering the transportation and storage of WP are to be applied (see the Dangerous Goods Manual - DGM).

5.6 Inert

5.6.1 Non-explosive and inert items should be boxed and certified Free From Explosives (CFFE). Where a box is utilised for packing for final disposal, the accounting reference of the items contained should be shown on the exterior. Items too large to be boxed are to be packed separately in cage/post pallets and an FFE certificate attached to each item or to the caged pallet in a prominent position. If any doubt exists that an item of EO is FFE, it must be treated as an explosive article and stored accordingly.

6 STANDARDS OF STORAGE FOR EOD ARISING

6.1 Licensing

6.1.1 The location, quantity and method of storing EOD arising are to be formally endorsed by the relevant IE and specified on the Explosives Licence(s) for the PES.

6.2 Standards of Storage

6.2.1 EOD arising are to be stored by Disposal Classification in isolated storage. While storage outside is not recommended, the relevant open stack site regulations apply.

6.3 Safety Certificate / Disposal Certification Form (MOD Form 1661)

6.3.1 EOD units without their own licensed storage are to arrange for storage with their parent unit. However, before presenting EOD arising for storage, the EOD operator is to certify that the item(s) are safe for segregated/isolated (as appropriate) storage. A copy of this certificate is to be placed on the item or stack.

6.4 Time Constraints

6.4.1 EOD arisings (except Forensic Evidence holdings) are to be stored for no longer than 60 days before being consigned and moved for final disposal. At the final disposal site, to allow flexibility in large-scale disposal programmes, the EOD arisings may be stored for a further 60 days from the date of delivery before being destroyed.

7 EOD CHEMICAL MUNITION ARISINGS

7.1 General

7.1.1 Chemical EOD arisings of CG 'K' are to be treated separately. Instructions for Anti-Riot natures and Chemical Training Items are at para 5.4, above. When necessary, chemical EOD arisings are to be stored in segregated storage.

7.2 Packaging

7.2.1 Packaging of recovered chemical munitions is the responsibility of the recovering unit in accordance with their procedures, as advised by DSTL Porton Down.

7.3 Transport

7.3.1 Items are to be moved to DSTL Porton Down by the consigning unit in accordance with local orders, and as advised by DSTL Porton Down. The CG K disapplication applies.

Intentional Blank Page

CHAPTER 13**ANNEX F****APPENDIX 1****UNEXPLODED ORDNANCE DISPOSAL CLASSIFICATIONS LIST**

Designation	Disposal Classification	UN Serial Number
Articles Explosive N.O.S.	1.1D	0463
	1.1E	0464
	1.1F	0465
	1.2C	0466
	1.2D	0467
	1.2E	0468
	1.2F	0469
	1.3C	0470
	1.4B	0350
	1.4D	0352
	1.4E	0471
	1.4F	0472
	1.4G	0353
	1.4S	0349
Components, Explosive Train N.O.S.	1.1B	0461
	1.2B	0382
Articles Pyrotechnic	1.1G	0428
	1.2G	0429
	1.3G	0430
	1.4G	0431
Ammunition Smoke White Phosphorus	1.2H	0245
Ammunition Toxic	1.2K	0020
	1.3K	0021

NOTE:

The Compatibility Group is almost immaterial (the HD being the important characteristic), but the combination of HD and CG is the only way that a complete classification and UN serial number can be allocated.

Intentional Blank Page

CHAPTER 13

ANNEX G

RESPONSIBILITY FOR THE CARE AND MAINTENANCE OF AMMUNITION IN THE FIELD

Serial (a)	Echelon (b)	Responsible Officer (c)	Technical Adviser (d)
1	1st line whether or not on wheels.	<p>Officer Commanding (OC) Unit.</p> <p>He is to:</p> <p>a. Arrange frequent inspections and take steps to prevent rough handling.</p> <p>b. Ensure turnover in accordance with lot numbers where applicable.</p> <p>c. Ensure that ammunition is held in its original packaging as far as operational circumstances permit.</p> <p>d. Ensure that stacked ammunition is held under the best possible conditions on dunnage, under cover of buildings or tarpaulins, and well ventilated.</p> <p>e. Ensure that unpainted portions of loose shell are coated with Corrosion Preventive Compound PX7.</p> <p>f. Report ammunition in bad or doubtful condition to the AT/ATO/ (RN, RAF or Civilian Equivalent) for inspection.</p>	<p>Ammunition Technical Officer (ATO) of the Formation or Area. Among their other duties ATOs are there to:</p> <p>a. Prevent deterioration of ammunition by advising on storage and maintenance problems.</p> <p>b. Supervise ammunition repairs carried out by units.</p> <p>c. Carry out unit technical inspections. ATOs are to have full access to unit ammunition, and the greatest possible use should be made of their services.</p>
2	2nd line on wheels. Distribution Points (DPs) and Immediate Replenishment Groups (IRGs).	<p>OC RLC Transport Squadron carrying the ammunition.</p> <p>He is to:</p> <p>a. prevent rough handling or bad stowage of the ammunition.</p> <p>b. protect the ammunition from rain and the direct rays of the sun.</p> <p>c. Arrange the ammunition in his vehicles to maintain the integrity of batches and lots when issuing to units.</p> <p>d. Report ammunition which is damaged or in doubtful condition to the AT/ATO/ (RN, RAF or Civilian Equivalent) for inspection and in the case of Guided Missiles (GM) to OC GM Troops.</p>	See Serial 1

Serial (a)	Echelon (b)	Responsible Officer (c)	Technical Adviser (d)
3	2nd line dumped. Divisional Supply Areas (DSAs).	OC of the Division Supply Area. The staff of the formation HQ concerned may have to allot protection, if required.	See Serial 1
4	3rd Line. Corps Supply Areas (CSAs).	OC Ammunition Squadron of the Corps Supply Area.	Corps Troops Senior ATO. See Serial 1
5	Force reserves.	These reserves are held in RLC Ammunition Depots Rear Maintenance Areas. Responsibility for care of ammunition rests with the OC of each depot.	Chief ATO at Force HQ.

CHAPTER 13**ANNEX H****READY USE MUNITIONS****CONTENTS**

Paragraph

1 READY USE MUNITIONS

- 1.1 Maintenance
- 1.2 Use of Containers
- 1.3 Care of Munitions
- 1.4 Care of Handling
- 1.5 Inspection of Munitions
- 1.6 Turnover of Ready Use Ammunition

1 READY USE MUNITIONS**1.1 Maintenance**

1.1.1 Other than the drying of munitions or removal of dirt or mud, any maintenance of munitions is to be carried out by a Technical Explosives Authority.

1.2 Use of Containers

1.2.1 Only the minimum number of containers is to be opened, consistent with firing requirements. The containers and furniture when emptied are to be stored in dry conditions for possible reuse. Unfired munitions are to be returned to their original containers to ensure that batch or lot identification is preserved.

1.2.2 All munitions are to be removed from a vehicle and returned to their original containers before the vehicle enters workshops for inspection or repair.

1.3 Care of Munitions

1.3.1 Ready use munitions are to be held in the coolest and driest place possible with protection from the direct rays of the sun and adverse weather conditions. They are to be kept clean and free from grit and corrosion.

1.3.2 Inflammable materials and those subject to spontaneous ignition are not to be placed near the munitions.

1.3.3 Ready use munitions are to be kept well clear of all batteries with exposed terminals, accidental contact could cause the munitions to function either spontaneously or after a short period of time.

1.3.4 Ready use munitions are to be inspected daily by an officer and a record of these inspections maintained in a register for the purpose.

1.4 Care in Handling

1.4.1 Once removed or separated from their containers munitions become particularly prone to damage. Special care in handling is essential if they are to remain serviceable.

1.4.2 Large Quick Fire (QF) fixed rounds are particularly susceptible to damage and once they are removed from their containers, the rounds are to be supported at the junction of the cartridge case and projectile, as well as at each end. Failure to support these rounds correctly can cause the round to sag and distort the cartridge case, with the consequence that the round will not load in the weapon.

1.4.3 Careless handling of Armour Piercing Discarding Sabot (APDS) rounds can cause loosening of the shot inside the sabot.

1.4.4 Cartridge cases can be easily dented if not handled with care.

1.4.5 For safety reasons, certain components of munitions are protected by cartridge clips or fuze caps. The clips or caps are to be maintained in position until use as they are easily lost through careless handling.

1.4.6 The primary and augmenting cartridges of mortar bombs are susceptible to damage and to deterioration through damp. Protection is provided by the tail cover or protector attached to the bomb, the carrier or cylinder in which the bomb is held and by the metal outer container. The three together provide the most effective protection, therefore containers should not be opened and the carrier or cylinders removed until it is absolutely necessary.

1.4.7 Grenades are particularly susceptible to damage through handling.

1.4.8 The bodies of a number of grenades are made from tin plate. These can easily be damaged, particularly at the sweated or soldered joints, where corrosion is also liable to form.

1.4.9 Hermetically sealed cylinders containing grenades are not to be opened until required under training or operational conditions.

1.4.10 Damage or deterioration to Grenades containing White Phosphorus (WP) may cause leakers. This is dangerous as fire and/or phosphorus burns to personnel may result. Units in possession of WP grenades are to have the means to immerse any leakers or containers housing leakers in water; this makes them safe so long as they are not subsequently exposed and allowed to become dry again. When any leaker is discovered, the Technical Explosives Authority is to be informed immediately.

1.4.11 In some grenades the detonator is attached to a length of safety fuze to provide the required delay. Should the safety fuze be unduly distorted from the correct shape for fitting into the grenade, the burning composition may be affected, leading to the unsatisfactory functioning of the grenade e.g. safety fuze of the detonator of such grenades should not be bent.

1.4.12 Compared with other natures of munitions, pyrotechnics are inherently unreliable. The outer casings of some pyrotechnics are manufactured from rolled paper and dampness will affect the filling and cause the paper to swell. In some older types of illuminating and signal cartridges, the swelling of the paper tube will prevent the cartridge from being loaded into the pistol.

1.4.13 Pyrotechnics are packaged so that the inner container gives the maximum protection from damp, it is therefore essential not to remove them from these containers until actually required for issue.

1.4.14 When ready use munitions are stored on Armoured Fighting Vehicles (AFVs) Self Propelled (SP) guns or in special vehicles, particular attention is to be paid to prevent

deterioration of munitions through water collecting and remaining in the munitions stowage places or through corrosion and damage from leaking or other causes.

1.5 Inspection of Munitions

1.5.1 The requirements for inspection of munitions before use are contained in the relevant user arm training manuals. Munitions are to be visually serviceable and any item of untoward appearance, e.g. any munitions with damaged fuzes, cracks in cartridge cases, split augmenting cartridges or heavy corrosion are to be put to one side and reported to the Technical Explosives Authority.

1.6 Turnover of Ready Use Ammunition

1.6.1 Ready Use ammunition may frequently be held loaded into weapon magazines and in some cases may be unloaded and loaded at every shift change. Hence, Ready Use ammunition should be expected to deteriorate as a result of excessive handling.

1.6.2 The turnover of Ready Use ammunition is to be detailed in local SOPs. It is recommended that:

1.6.3 Ammunition, which is frequently loaded, unloaded and otherwise handled, should be turned over at three monthly intervals.

1.6.4 Ammunition which is not held in its Full Service Standard Pack (FSSP) is turned over annually.

1.6.5 Whenever possible the local Technical Explosives Authority should arrange for the unit to expend Ready Use ammunition at training. This ammunition may be consumed over and above a unit's entitlement. Authority to do so must be obtained from the formation headquarters ammunition supply manager. If so, it may not count against the unit's annual training entitlement.

1.6.6 Any Ready Use ammunition displaying heavy wear and tear, i.e. cracks, splits, heavy scores with raised metal, dents and corrosion is to be set aside for inspection by the local Technical Explosives Authority.

Intentional Blank Page

CHAPTER 13**ANNEX I****STORAGE OF EXPLOSIVES HELD IN SAFE CUSTODY AS POLICE EVIDENCE****CONTENTS**

Paragraph

1 STORAGE OF EXPLOSIVES HELD IN SAFE CUSTODY AS POLICE EVIDENCE

- 1.1 Introduction
- 1.2 Legal Status
- 1.3 Classification
- 1.4 Safe to Store
- 1.5 Recording and Disposal
- 1.6 Packaging and Marking
- 1.7 Fireworks
- 1.8 Storage

1 STORAGE OF EXPLOSIVES HELD IN SAFE CUSTODY AS POLICE EVIDENCE**1.1 Introduction**

1.1.1 Some units, especially EOD units carrying out duties in support of Military Aid to the Civil Powers (MACP), Ministry of Defence Police (MDP) or the Service Police, are often requested to provide explosives storage facilities in which to store police evidence.

1.2 Legal Status

1.2.1 Owing to its legal status, police evidence shall not be altered or interfered with in any way that may affect any future legal process and care must always be taken to ensure that this principle is strictly complied with. Where an EOD unit is to store police evidence on behalf of a police authority, chain of evidence procedures must be discussed with the owning authority before accepting any item into store.

1.3 Classification

1.3.1 Many police evidence items will not be classified for storage and therefore all items that are not classified by DOSR are to be classified under the EOD Classification rules which are detailed at Appendix 1 to Annex F.

1.4 Safe to Store

1.4.1 Only items that are safe to store are to be held by the MOD in Safe Custody. Suspect items shall not be accepted from any organisation requesting storage. Items without explosives content are not to be accepted into explosives stores and should be retained by the police authority. All explosives items accepted into store are to be certified as Safe to Store on MoD Form 1661. Where the age and previous storage conditions of the items are unknown, periodic inspections of the items are to be conducted to ensure that there is no visible deterioration and they remain safe to store. Such inspection intervals are not to exceed 6 months. Prior to inspecting any police evidence items, the owning organisation must be contacted in order to ensure that the continuity of evidence is preserved.

1.5 Recording and Disposal

1.5.1 Detailed records are to be maintained for all items held in Safe Custody. This should be carried out in a register, or similar, raised for the specific purpose. Full details of all items held are to be maintained together with details of the organisation for which the items are held and the contact details of the person responsible for them. Frequent checks with the owning authority are to be made in order to confirm the continuing need to store; this shall be no longer than at 6 monthly intervals. The disposal of any item being held in Safe Custody shall only be undertaken following receipt of written authority from the owning organisation.

1.6 Packaging and Marking

1.6.1 Where practicable, all items are to be over-packed in suitable metal containers, sealed, and marked with the package quantity, the item's proper designation or a designation from the Unexploded Ordnance Disposal Classifications List, DOSR or Disposal Classification, UN Serial Number, Hazard Classification Code label and the package All Up Weight in kg. Prior to any movement by road, police evidence is to be certified as "Safe to Move".

1.7 Fireworks

1.7.1 When any police evidence item(s) comprise(s) fireworks, particular care is to be taken due to the inherent weakness of the paper or cardboard cases and the high probability of spillage of the filling. Firework fillings are very sensitive to impact, friction, heat or sparks and, where practicable, are to be suitably over-packed to prevent the leakage of black powder or pyrotechnic composition.

1.8 Storage

1.8.1 In all instances, police evidence items held in Safe Custody are to be stored in storage accommodation that is isolated from all other munitions. Where this is not possible, all police evidence items must be segregated from other munitions and advice immediately sought from the relevant Inspector of Explosives.

CHAPTER 13**ANNEX J****STORAGE OF EXPLOSIVES IN THE FIELD AND UNDER EMERGENCY CONDITIONS****CONTENTS**

Paragraph

1 STORAGE OF EXPLOSIVES IN THE FIELD AND UNDER EMERGENCY CONDITIONS

- 1.1 Field Storage
- 1.2 Emergency Conditions
- 1.3 Ready Use Munitions

1 STORAGE OF EXPLOSIVES IN THE FIELD AND UNDER EMERGENCY CONDITIONS**1.1 Field Storage**

1.1.1 There are separate regulations covering the siting and deployment for the Field Storage of explosives both in support of operations and exercises. Further information is available on this from the local Technical Explosives Authority.).

1.1.2 Explosives stored in the open require greater separation distances between the site containing explosives (Potential Explosive Site) under consideration and Exposed Sites, such as adjacent explosives sites or dwellings and roads, than is the case for permanent storage. Certain safety critical distances must be observed which will be determined by the local Technical Explosives Authority.

1.1.3 A Field Storage Area will require firm, well drained ground and be served with a good network of tracks or metalled roads which can be used in all weathers by heavy vehicles and equipment. Ideally, use should be made of covered accommodation such as warehouses or barns to provide protection against the weather or direct sunlight. Due to the wide dispersion of stocks, an area of up to two kilometres square or more may be required and will depend on the explosives natures to be held, the quantities involved and the local terrain.

1.1.4 In all cases the advice of the local Technical Explosives Authority must be sought. The local Technical Explosives Authority will be responsible for conducting the initial reconnaissance and recommending the detailed siting of the Field Storage Area and deployment of stocks on the ground.

1.2 Emergency Conditions

1.2.1 There are occasions when explosives will need to be held under Emergency Conditions. When this arises the period that explosives will be held under these conditions must be clearly specified. At the end of this period the situation is to be re-examined with a view to withdrawing the explosives from emergency storage or to having approved permanent storage built.

1.2.2 It is essential to obtain guidance from the local Technical Explosives Authority on the emergency storage requirements as soon as possible.

1.2.3 Explosives are to be stored, as far as is practicable, in accordance with the regulations set out in DSA 02.OME.

1.2.4 Protection of explosives from adverse weather or the effects of solar radiation, is most important, since it will deteriorate in time if left unprotected. Whenever possible buildings or covered accommodation such as barns, should be used. Iron Galvanised (IG) shelters may be used as a substitute.

1.2.5 When IG shelters are used, explosives are to be stacked so as to allow free circulation of air around the stack and to ensure that the shelter itself overhangs the explosives by at least 0.5m at each end. The need for end covers to the shelter will be dictated by local conditions. Tarpaulins used for this purpose are to be fixed so as to permit ventilation, or failing this, they are to be raised periodically to enable free circulation of air.

1.2.6 Tarpaulins are to be used to protect explosives stored in the open. Direct contact with the metal surface of an ammunition container however, can raise the temperature of the contents very significantly in very hot weather and the explosives could begin to deteriorate. It is important that tarpaulins are raised 150mm to 250mm above the stacks of explosives by use of some means such as a light framework and positioned so that there is free circulation of air around the explosives.

1.2.7 Dunnage (wood or bricks) is to be used to raise the explosives off the ground and the ground should be levelled where necessary.

1.2.8 ISO containers provide an effective and convenient means of temporary explosives storage. The siting of the container(s) should be agreed with the local Technical Explosives Authority. ISO containers are prone to creating humid conditions without regular ventilation, the doors should be opened and the container vented regularly to prevent this.

1.2.9 The storage area is to be inspected regularly by an officer who is to ensure that the explosives are stored in accordance with these regulations and in particular that;

- (1) The protection from adverse weather conditions is effective.
- (2) There is no risk of flooding, especially if the explosives are dug in below ground level.

1.3 Ready Use Munitions

1.3.1 The regulations governing the storage of Ready Use Munitions are covered in this document.