



Defence
Safety Authority

DSA 03.OME Part 2 (JSP 482) - Defence Code of Practice (DCOP) and Guidance Notes for In-Service and Operational Safety Management of OME

Defence OME Safety Regulator

DOSR



DSA VISION

Protecting Defence personnel and operational capability through effective and independent HS&EP regulation, assurance, enforcement and investigation.

PREFACE

AUTHORITY

1. This document is crown copyright and the intellectual property rights of this publication belong exclusively to the Ministry of Defence (MOD). However, material or information contained in this publication may be reproduced, stored in a retrieval system or transmitted in any form provided it is used for the purposes of furthering safety and environmental management.

STATUS

2. This document:
 - a. Is uncontrolled when printed.
 - b. Will be updated as part of a continuous improvement programme but at least 12-monthly from the period of document issue date.

REQUESTS FOR CHANGE

3. Proposed changes, recommendations or amendments to DOSR Regulations and Guidance publications can be submitted by anyone using the DOME Request for Change Function (RFC) available for every Dome publication in the DOME library located [here](#) or by completing the Word version of the Change Proposal Form available from the DOME Library, see figure 1 below for the location.

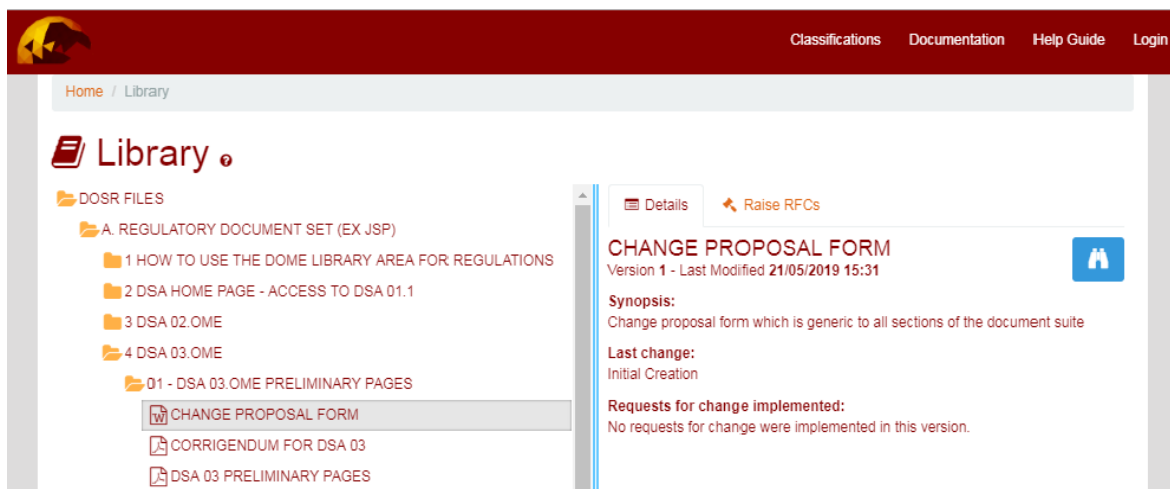

Figure 1. Change Proposal Form (Word version) Location

4. Any post and grammar change proposals can be approved or rejected by the DOSR PRG Authors without involvement of the associated Working Group.
5. Technical change proposals will need to be submitted to the associated Working Group for review and approval or rejection.
6. When incorporating changes care is to be taken to maintain coherence across regulations.
7. Changes effecting Risk to Life will be published immediately.
8. Other changes will be incorporated as part of routine reviews.

REVIEW PROCESS

9. The DOSR PRG team will ensure these OME Regulations remain fit for purpose by conducting reviews through the DOSR Governance Committees, involving all Stakeholders.

FURTHER ADVICE AND FEEDBACK

10. The document owner is the DOSR. For further information about any aspect of this document, or questions not answered within the subsequent sections, or to provide feedback on the content, contact:

Job Title	DOSR-Policy, Regulations and Guidance
E-mail	DSA-DOSR-PRG@mod.gov.uk
Address	Juniper #5004, Level 0, Wing 1, Abbey Wood North, Bristol, BS34 8QW

Intentional Blank Page

CHAPTER 7**TRAVERSES****CONTENTS**

Paragraph

- 1 FUNCTION OF A TRAVERSE
 - 1.1 Introduction
 - 1.2 General
 - 1.3 Position of Traverses
- 2 CLASSIFICATION OF TRAVERSE TYPES
 - 2.1 General
 - 2.2 Receptor Traverse
 - 2.3 Interceptor Traverse
 - 2.4 Container Traverse
 - 2.5 Screening Traverse
- 3 EARTH TRAVERSES
 - 3.1 Introduction
 - 3.2 Geometry – Height
 - 3.3 Geometry – Length
 - 3.4 Traverse Slopes
 - 3.5 Materials for Traverses
 - 3.6 Other Factors
- 4 OTHER TRAVERSE MATERIALS
 - 4.1 General
 - 4.2 Wall Traverses
- 5 OTHER TYPES OF TRAVERSES
 - 5.1 General
 - 5.2 Airfield Barriers, Traverses and Flare Catchers/Deflectors

Table

- 1 Thickness Required for Cantilever Container Traverses

Annex

- A Design and Construction of Traverses
- B Determination of Traverse Height and Length
- C Materials for Traverses

1 FUNCTION OF A TRAVERSE

1.1 Introduction

1.1.1 This chapter provides technical data on the purpose and construction of traverses.

1.2 General

1.2.1 A traverse is a barrier intended, primarily, to intercept the high velocity fragments from an explosive event on one side and prevent the initiation of explosives stored on the other. Natural ground features may be used for this purpose, but the most common forms are artificial earth mounds, reinforced concrete and masonry walls, or a combination of these types. A traverse may be completely destroyed in an explosion, but its design must be such that it will stop or sufficiently slow down high velocity fragments before it collapses.

1.2.2 To be effective, a traverse must be constructed of properly specified materials to a minimum effective thickness. Traverses will also protect personnel from high velocity missiles, intercept fragments, and shield an Exposed Site (ES) from blast and flame. However, the primary function remains to be the prevention of initiation of explosives by high velocity fragments.

1.3 Position of Traverses

1.3.1 The traverse should be as close as possible to either the PES or the ES, depending on its purpose. Ideally the traverse toe or face should be positioned 1 metre from the stack of explosives, or wall of any building, it protects. However, access for stock and/or building maintenance may require a greater distance and hence a larger traverse. In addition, for HD 1.1, where a traverse may be undermined by the potential crater, or the NEQ exceeds 75 000 kg of HD 1.1, the traverse should be moved outwards to avoid undermining (see Annex A). Alternatively, the thickness of the traverse can be increased in proportion to the quantity of explosives so that at least 2/3 of its base is excluded from the crater. The approximate crater diameter (D) in metres is given by the formula:

$$D = Q^{1/3} \text{ (where Q is the NEQ in kg)}$$

1.3.2 For a more accurate prediction of crater size, particularly where undermining may occur, appropriate design methods shall be employed (Chapter 6). These take into consideration both the depth of burst and the soil or other material type in which the crater is formed including any concrete slab effects.

2 CLASSIFICATION OF TRAVERSE TYPES

2.1 General

2.1.1 Traditionally, traverses have been classified into four types according to the nature of protection provided. It is not always possible to distinguish clearly between traverse types, as their functions merge according to their position relative to an ES or a Potential Explosion Site (PES). However, it is still considered that the classification by function is useful because it indicates a measure of the traverse strength required.

2.1.2 The types of traverse are as follows:

2.2 Receptor Traverse

2.2.1 A Receptor Traverse protects the explosives within the ES it surrounds from direct attack by low angle, high velocity fragments and debris projected from an explosion in an adjacent PES. This type of traverse can be used for ES where the explosive quantities are too large for an interceptor traverse at the PES to be effective. A receptor traverse should be as close as possible to the ES it is protecting.

2.3 Interceptor Traverse

2.3.1 An Interceptor Traverse is positioned close to the PES and is designed to protect explosives at the ES from direct attack by low angle, high velocity fragments. The traverse can be undermined by the crater and destroyed by the blast loading, but it must remain in position long enough to intercept and retard fragments before it collapses.

2.4 Container Traverse

2.4.1 A Container Traverse is designed to contain the high velocity fragments projected from an explosion within. It protects personnel and ES in the vicinity from the effects of an internal explosion and must therefore remain substantially intact after an explosion. This is practical only for small quantities of explosives (less than 1000 kg) and therefore may be usable only around certain Process Buildings or relatively small stacks of explosives.

2.5 Screening Traverse

2.5.1 A Screening Traverse is designed as a screen between the PES and ES to intercept fragmentation at a higher angle than is normal for a traverse. It may be situated at the ES but is more effective if situated at the PES. If it is located at a PES, to be effective, it must be high enough to intercept all fragments projected at 40° or less and remain substantially intact after an explosion. The 40° line is measured from the centre of the top of the explosives stack if the roof is lightweight, and from the centre of the roof if it is not lightweight construction.

3 EARTH TRAVERSES

3.1 Introduction

3.1.1 Proper traverse geometry is necessary to reduce the risk of high velocity fragments or debris escaping above or around the ends of the traverse. Reasonable margins in traverse dimensions that block lines of sight are to be provided.

3.2 Geometry – Height

3.2.1 To eliminate any potential line of sight problems, the limiting dimensions for an earth traverse are normally controlled by the 2-degree rule, which is illustrated at Annex B. The 2-degree rule does not apply to separation distances between PES greater than $5Q^{1/3}$.

3.2.2 Where PES are separated by distance of $5Q^{1/3}$ or greater, traverses are to be assessed on an individual basis.

3.2.3 Where existing traverses do not meet these criteria, a Technical Assessment should be carried out by TA (Structures) to determine the continued suitability of the traverse.

3.2.4 A traverse may also be built with a minimum traverse width of 2.4 m at a level equivalent to the maximum height of the explosives, plus 600mm

3.2.5 A traverse may also be built to the height of the eaves of the building which the traverse protects. These requirements are illustrated at Annex A.

3.2.6 Where low stacks of explosives are stored in a PES and the 2-degree rule leads to traverses being lower than the eaves of the building, consideration is to be given to increasing the traverse height up to the building eaves to assist in limiting building debris throw. For all new construction, other than truly light structures the traverse height shall be at or above eaves level. In exceptional circumstances, where this would lead to unusually high traverses, advice should be sought from DSA DOSR CIE MOD.

3.3 Geometry – Length

3.3.1 If a traverse does not completely surround the PES it protects, it is to extend, without any reduction in overall height, sufficiently beyond the sides of the PES to eliminate any potential lines of sight to other PES/ES. The length of a traverse is subject to an overriding minimum extension of 1 m at each end of the traverse on all traversed sides of the PES (see Annex B).

3.4 Traverse Slopes

3.4.1 Traverse slopes are to be so as to ensure stability of the traverse materials but should normally be no steeper than 1:2, or 26° from the horizontal.

3.5 Materials for Traverses

3.5.1 It is probable that an explosion may disperse the material used for a traverse, particularly if it is vertically or near vertically faced, resulting in a debris hazard. This debris may initiate adjacent explosives and present a hazard to personnel. To minimise these effects, materials to one of the specifications (in order of preference) in the table at Annex C are to be used in the construction of earth traverses.

3.5.2 The stability of the slope should be checked on a case by case basis. The required factor of safety against rotational slip will depend on the function of the traverse, consequences of failure to safe use of the facility and the degree of disruption caused while repairs are being carried out if failure occurs. However, the factor of safety should not be less than 1.2 in the long term.

3.5.3 In the case of a reinforced fill slope, information from the reinforcement manufacturer would be required to determine number and type of reinforcements, embedded lengths and vertical spacing. Therefore, the manufacturer's early involvement in the design process should be sought. Where a vertical, or near vertical (greater than 70 degrees) face using a wrap-around detail or pre-cast concrete facing element is envisaged for the reinforced fill, the fill material should be free-draining and must comply with the requirements of the manufacturer of the reinforcement. Since such a configuration constitutes a 'wall', the factor of safety against sliding should not be less than 2, and that against rotational slip not less than 1.5.

3.6 Other Factors

3.6.1 Measures should be taken to prevent the burrowing of rabbits or similar creatures into a traverse. Advice and typical details of protection from burrowing animals may be obtained from DIO.

3.6.2 Where a traverse is unlikely to be dispersed by an explosion, it does not need to be constructed of special materials. However, to provide a degree of flexibility, it would be prudent to adopt one of the material specifications listed in the table at Annex C in case the role of the traverse was to change.

3.6.3 Earth cover for earth covered buildings and igloos must meet the requirements of the materials listed in the table at Annex C.

4 OTHER TRAVERSE MATERIALS

4.1 General

4.1.1 When brick, concrete or steel is used to support the vertical face of a Type II or Type III Traverse, their effectiveness in stopping high velocity fragments is increased compared with earth. This effectiveness can be quantified as 4, 6 and 24 times greater than soil respectively and the traverse thickness may be reduced accordingly. However, the

equivalent mass of an interceptor traverse should not be reduced below 2.4 m of earth at the top level of the stack or eaves of the PES to prevent dispersion of the traverse occurring.

4.2 Wall Traverses

4.2.1 The concrete or masonry walls of buildings, when properly designed, may be used as traverses. Where explosives stocks are to be preserved or personnel are to be protected, the walls should be designed to resist collapse. For small NEQs, often present in Process Buildings, Table 1 gives the thickness required for cantilever container traverses of 3 m maximum height at 1 m stand off from the explosives to prevent collapse. For larger NEQs, advice should be sought from TA (Structures) through the appropriate IE.

5 OTHER TYPES OF TRAVERSES

5.1 General

5.1.1 There may be occasions when, for temporary expediency, or for emergency/field storage, other forms of improvised traverse will have to be considered. These may be stocks of non-explosive components or explosives of HD 1.4 in certain circumstances (see Chapter 11), but are more often in the form of proprietary brands such as:

- (1) Hesco-Bastion Walls, the filling of which must meet the requirements of the materials listed in the table at Annex C.
- (2) Titan Water Tank Barriers.
- (3) Splinter Protection Units (SPUs)/Pendine Blocks.
- (4) For some specific purposes (see Chapter 10), barriers inside certain structures may be required. These internal barriers are to take the form of an un-mortared autoclaved aerated concrete block (such as 'Thermalite', 'Aglite', etc) wall.

5.1.2 Advice on the capabilities and use of these types of traversing can be obtained from relevant IE or DSA DOSR CIE(MOD) staff.

TABLE 1 - THICKNESS REQUIRED FOR CANTILEVER CONTAINER TRAVERSES		
NEQ kg	RC Wall Thickness Butressed at 3 m Centres, 0.2% Tension Reinforcement (mm)	Nominal Brick Wall Thickness (mm)
2.5	225	340
5	225	340
7	225	450
12	225	570
18	300	680
35	450	
50	600	
68	750	

5.2 Airfield Barriers, Traverses and Flare Catchers/Deflectors

5.2.1 Airfield Barriers, Traverses and Flare Catchers/Deflectors:

- (1) Barriers Artificial barriers of any type (e.g. Hesco-Bastion) may be used to minimise the hazards from directional weapon systems (see Chapter 10, Section 5) providing they have been approved by the appropriate IE, who should consult with DSA DOSR CIE MOD staff on their constructional and siting requirements. The minimum requirements of a barrier are that it must be capable of complete disruption or capture of missiles, flares or gun ammunition prior to the functioning of any arming or fuzing system that may be fitted.

(2) **Vertically Faced Traverses** A traverse built with a vertical side facing the launch platform may be used to minimise the hazards from directional weapon systems provided:

- (a) The IE has approved the type and method of construction.
- (b) It is positioned at right angles to the most probable line of fire
- (c) The length of the barrier encompasses an arc of 5° either side of the probable line of fire¹.
- (d) The height of the barrier exceeds the height of the probable line of fire¹ or the probable point of impact by 1 m.

(3) **IR Flare Catchers or Deflectors** IR flare catchers or deflectors may be used providing their effectiveness has been tested in trials conducted by a competent authority, and the aircraft IPT has authorised their use.

¹ The probable line of fire is to be taken as a projection of the centre line of the weapon system whilst it is installed on the launch platform.

CHAPTER 7**ANNEX A****DESIGN AND CONSTRUCTION OF TRAVERSES****CONTENTS**

Paragraph

1 Constructional Designs

Appendixes

- 1 Type I Standard Double Slope
- 2 Type II Single Slope Vertical Face Type
- 3 Type II Partly Vertical Partly Sloped Face Type
- 4 Type III Steep Double Slope ('Chilver') Traverse
- 5 Type V Wall Traverse

CONSTRUCTIONAL DESIGNS

1 There are six constructional designs of traverses, described below and illustrated at Appendix 1 to Appendix 5.

TRAVERSE TYPE	DESCRIPTION
I	Double slope earth mound.
II	Single slope vertical face earth mound (or partial vertical face mound).
III	Steep double slope earth mound or 'Chilver' type.
IV	'Bunker' building or 'combined' traverse. This includes fully buried buildings not more than 600 mm below ground level.
V	Wall traverses constructed of brick, reinforced concrete and composite construction.
VI	Natural features of site e.g. Hillocks. These are to be the same as a Type I at a minimum size.

NOTES:

- (1) Types I, II and III comprising of sloping traverses are the most commonly used for storage purposes, as they can function in all four protective roles (Interceptor, Receptor, Container and Screening)
- (2) Type IV traverses make use of the PES structure to support the earth cover.
- (3) Type V traverses are primarily used as receptor traverses or, if correctly designed, as container traverses.

Intentional Blank Page

**CHAPTER 7, ANNEX A, APPENDIX 1
TYPE I STANDARD DOUBLE SLOPE**

ALL DIMENSIONS IN m

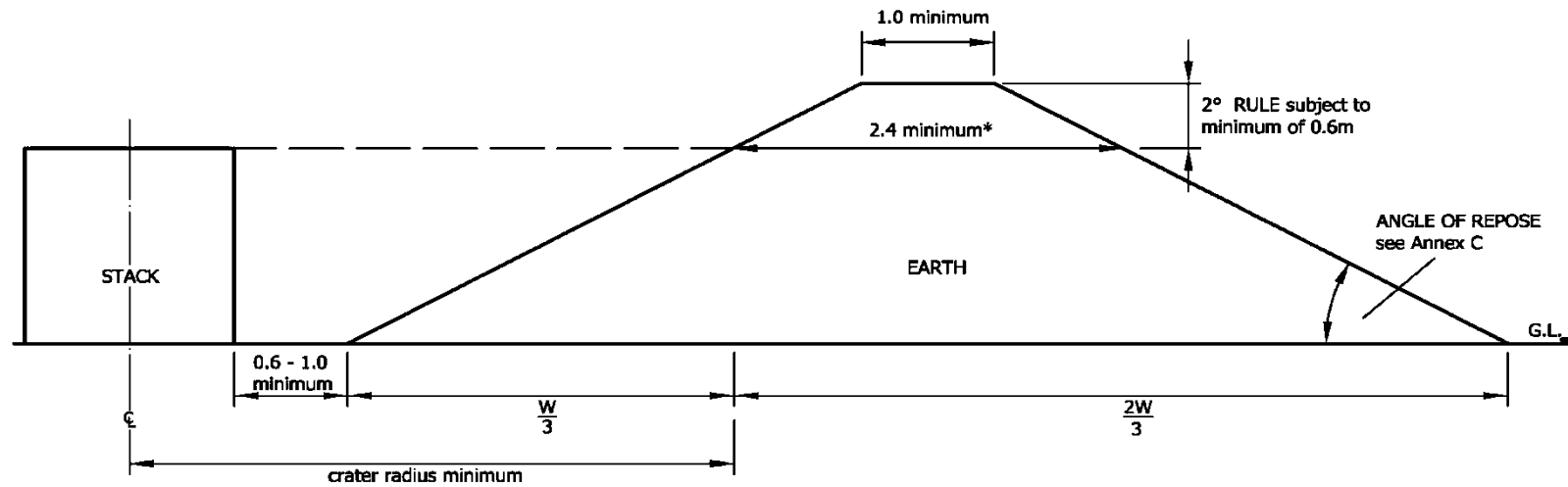

*** Note**
For $Q > 70,000\text{kg}$ increase traverse width proportional to increase in Q

**CHAPTER 7, ANNEX A, APPENDIX 2
TYPE II SINGLE SLOPE VERTICAL FACE TYPE**

ALL DIMENSIONS IN m

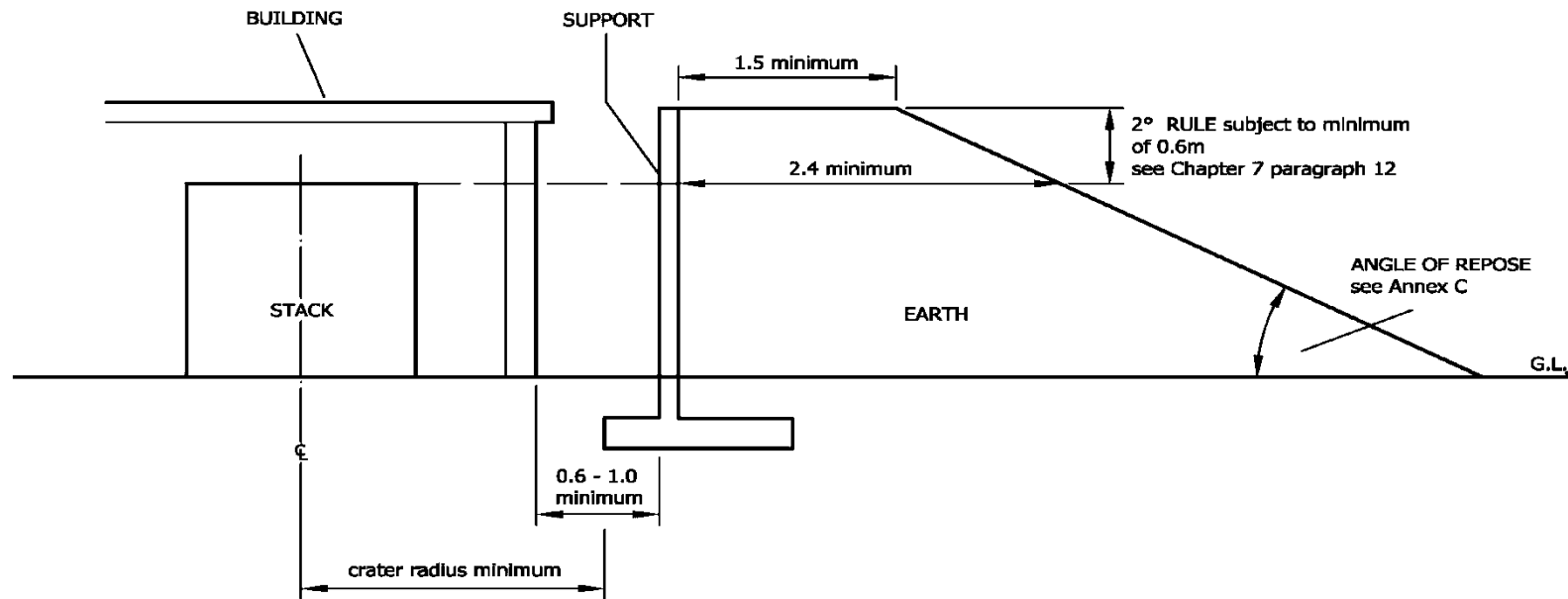

**CHAPTER 7, ANNEX A, APPENDIX 3
TYPE II PARTLY SLOPED FACE TYPE**

ALL DIMENSIONS IN m

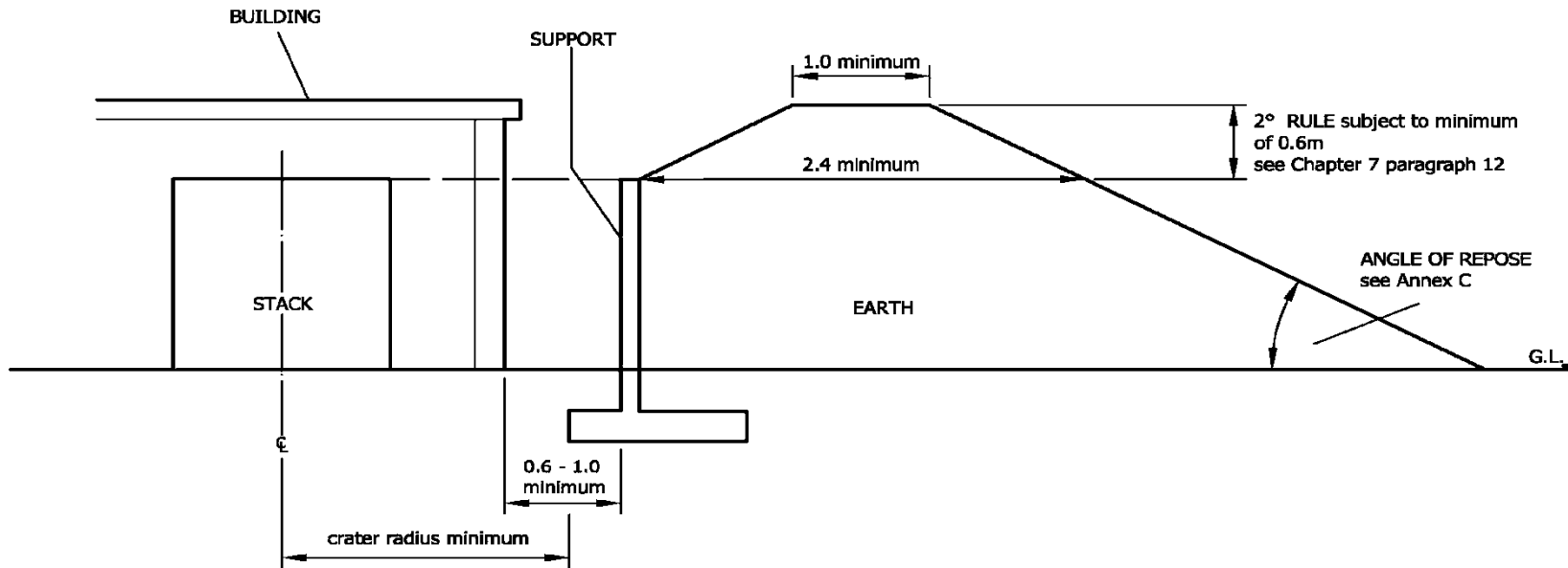

**CHAPTER 7, ANNEX A, APPENDIX 4
TYPE III STEEP DOUBLE SLOPE ('CHILVER') TRAVERSE**

ALL DIMENSIONS IN m

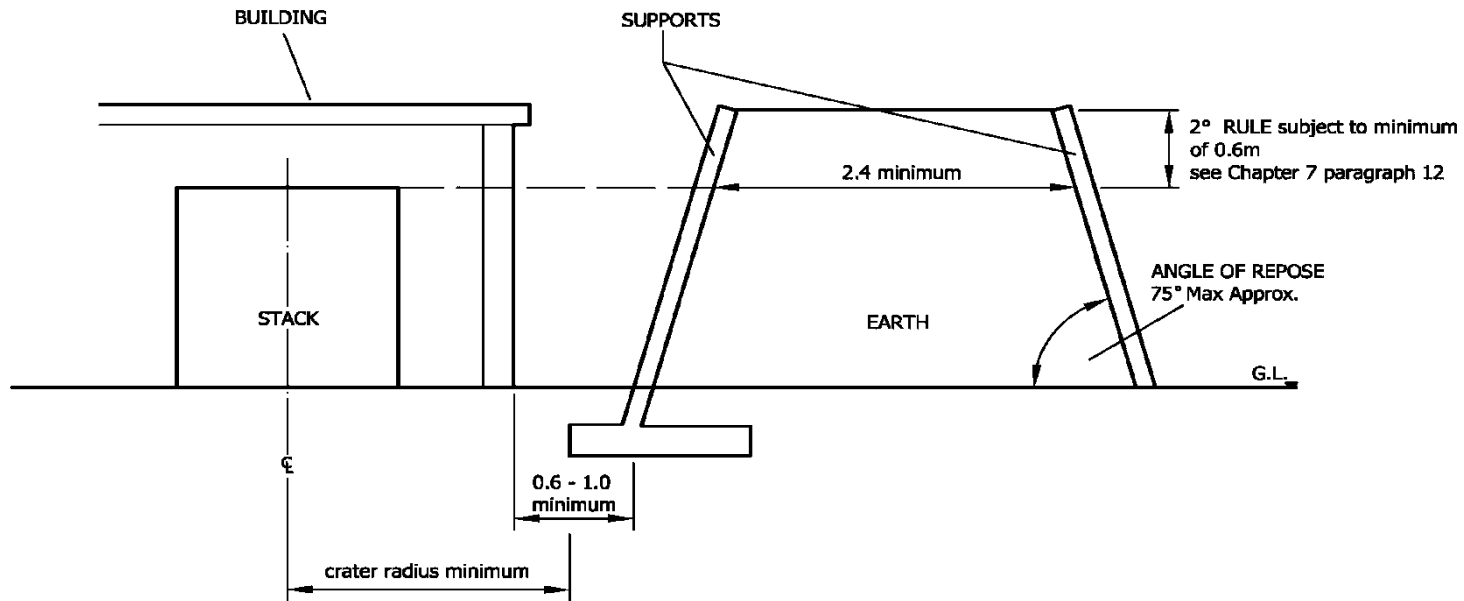

**CHAPTER 7, ANNEX A, APPENDIX 5
TYPE V WALL TRAVERSE**

ALL DIMENSIONS IN m

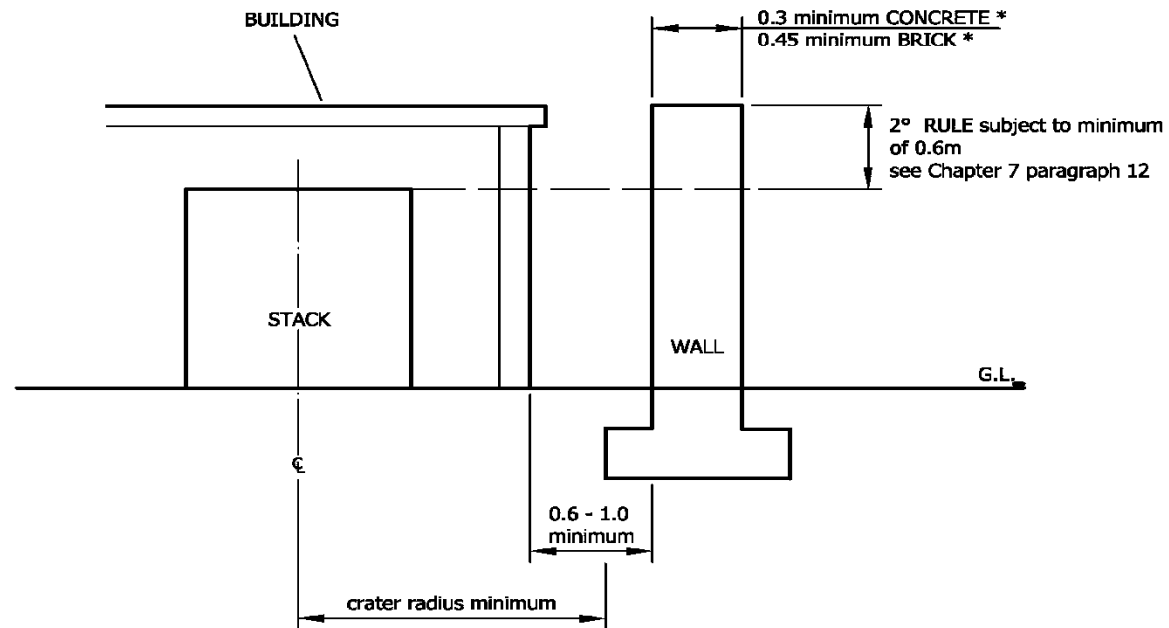

*** Note**
 Minimum total thickness of traverse and building walls:
 Concrete - 0.45m
 Brickwork - 0.7m

Intentional Blank Page

**CHAPTER 7, ANNEX B
DETERMINATION OF TRAVERSE HEIGHT AND LENGTH**

ALL DIMENSIONS IN m

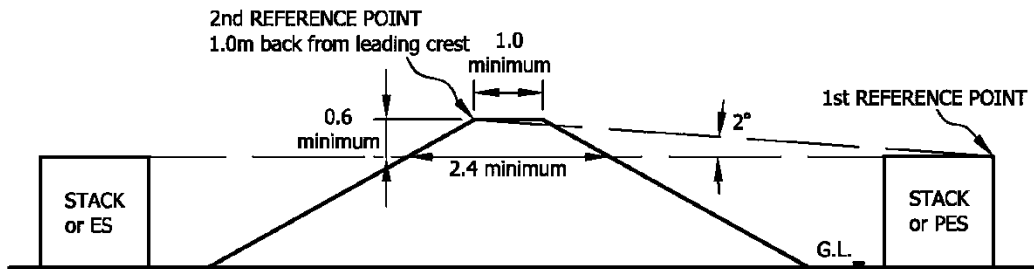

Figure 1 - Determination of Traverse Height on Level Terrain

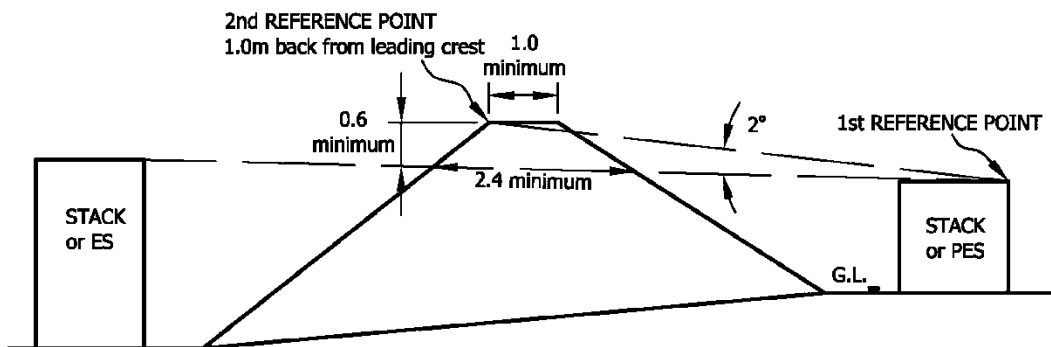

Figure 2 - Determination of Traverse Height on Sloping Terrain

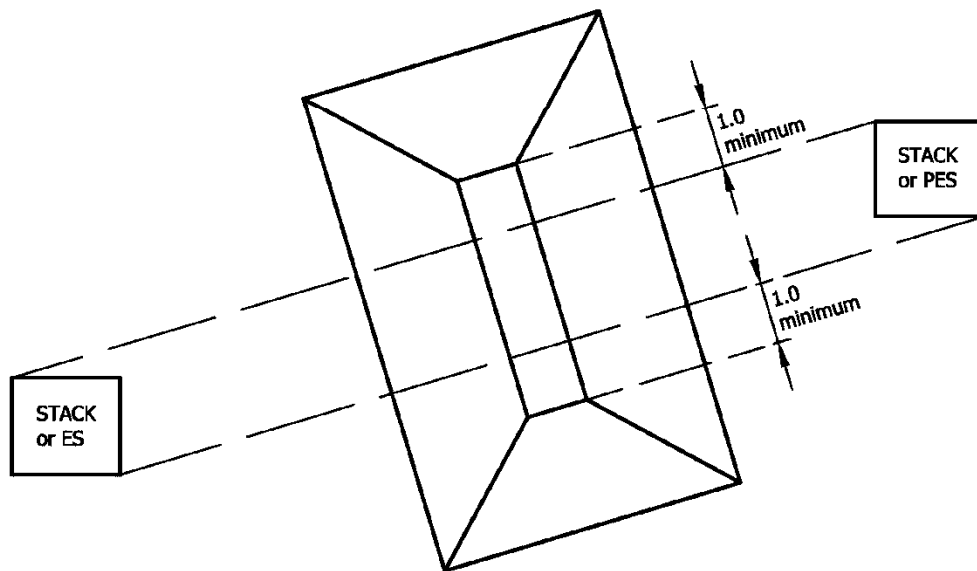

Figure 3 - Determination of Traverse Length

CHAPTER 7

ANNEX C

MATERIALS FOR TRAVERSES

Material Description (In order of preference)	Grading Limits ⁽¹⁾⁽²⁾				Design Slope ⁽⁴⁾ (dependent on soil mechanics)
	Coarse Material		Fine Material		
	Maximum Particle Size	Maximum Content (% by Weight: 20 to 75mm)	Maximum Fines Content (% by weight < 63µm)	Maximum Clay Content (% by weight < 2µm)	
Well graded Sand	6.3mm	0%	15% ⁽¹⁾	5% ⁽¹⁾	1:1.5 to 1:2 (33° to 26°)
Well graded Gravelly or Clayey or Silty Sand (inorganic)	75mm (in any measured direction)	5% ⁽¹⁾	20% ⁽¹⁾	5% ⁽¹⁾	1:1.3 to 1:2.5 (37° to 21°)
Inorganic fill ⁽³⁾	Other inorganic material meeting the above grading requirements				

NOTES:

- (1) Both coarse and fine particles must be uniformly distributed throughout the material to provide a reasonably homogenous fill.
- (2) The material used should have a Uniformity Coefficient (D_{60} / D_{10}) of 6 or greater.
- (3) Rubble from demolished buildings or any other similar material must not be used in the construction of traverses due to the risk of enhanced projection hazard.
- (4) Slope stability requirements are defined in Chapter 7, para 3.4. Design slopes tabulated are indicative only and will depend on many factors such as:
 - (a) Nature and strength of foundation soil/rock and depth to the water table.
 - (b) The degree of compaction and surface preparation provided to the fill.
 - (c) The fines content and erosion potential of the fill materials.
 - (d) The compaction moisture content where the fill materials are not free draining.
 - (e) The provision of drainage measures to control short/long-term pore water pressures.
 - (f) Whether the fill is reinforced with geo-synthetics, wire mesh etc.