



Defence
Safety Authority

DSA 03.OME Part 2 (JSP 482) - Defence Code of Practice (DCOP) and Guidance Notes for In-Service and Operational Safety Management of OME

Defence OME Safety Regulator

DOSR



DSA VISION

Protecting Defence personnel and operational capability through effective and independent HS&EP regulation, assurance, enforcement and investigation.

PREFACE

AUTHORITY

1. This document is crown copyright and the intellectual property rights of this publication belong exclusively to the Ministry of Defence (MOD). However, material or information contained in this publication may be reproduced, stored in a retrieval system or transmitted in any form provided it is used for the purposes of furthering safety and environmental management.

STATUS

2. This document:
 - a. Is uncontrolled when printed.
 - b. Will be updated as part of a continuous improvement programme but at least 12-monthly from the period of document issue date.

REQUESTS FOR CHANGE

3. Proposed changes, recommendations or amendments to DOSR Regulations and Guidance publications can be submitted by anyone using the DOME Request for Change Function (RFC) available for every Dome publication in the DOME library located [here](#) or by completing the Word version of the Change Proposal Form available from the DOME Library, see figure 1 below for the location.

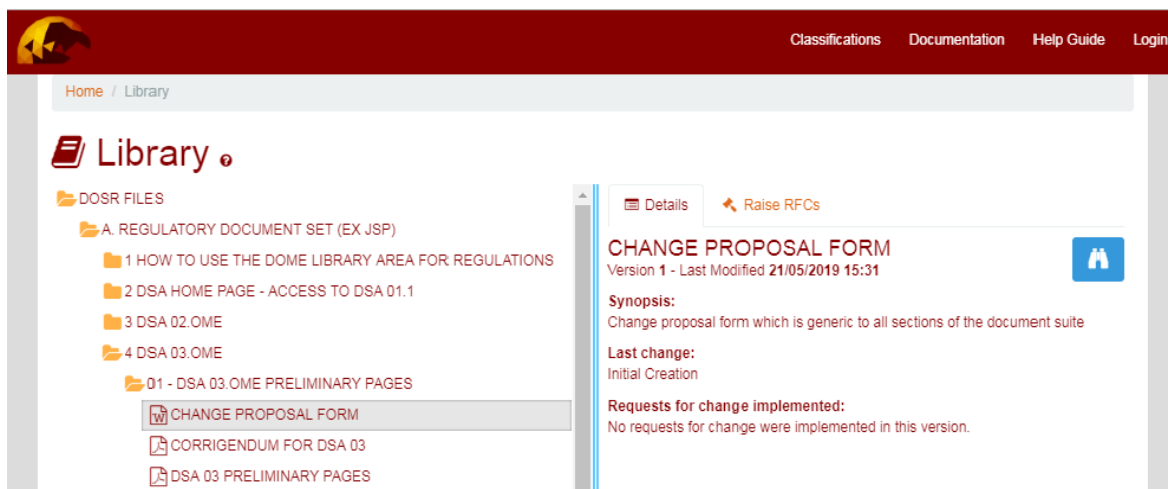

Figure 1. Change Proposal Form (Word version) Location

4. Any post and grammar change proposals can be approved or rejected by the DOSR PRG Authors without involvement of the associated Working Group.
5. Technical change proposals will need to be submitted to the associated Working Group for review and approval or rejection.
6. When incorporating changes care is to be taken to maintain coherence across regulations.
7. Changes effecting Risk to Life will be published immediately.
8. Other changes will be incorporated as part of routine reviews.

REVIEW PROCESS

9. The DOSR PRG team will ensure these OME Regulations remain fit for purpose by conducting reviews through the DOSR Governance Committees, involving all Stakeholders.

FURTHER ADVICE AND FEEDBACK

10. The document owner is the DOSR. For further information about any aspect of this document, or questions not answered within the subsequent sections, or to provide feedback on the content, contact:

Job Title	DOSR-Policy, Regulations and Guidance
E-mail	DSA-DOSR-PRG@mod.gov.uk
Address	Juniper #5004, Level 0, Wing 1, Abbey Wood North, Bristol, BS34 8QW

Intentional Blank Page

CHAPTER 6**BUILDINGS ASSOCIATED WITH MILITARY EXPLOSIVES****CONTENTS**

Paragraph

- 1 BUILDINGS ASSOCIATED WITH MILITARY EXPLOSIVES
 - 1.1 Introduction
- 2 CONSEQUENCES OF AN EXPLOSIVE EVENT
 - 2.1 Hazards to be Protected Against
 - 2.2 Projection Hazards – All PES Types
- 3 QUANTITY DISTANCES FOR AIR-BLAST EFFECTS
 - 3.1 Introduction
 - 3.2 Open Stacks and Light Structures
 - 3.3 Earth-Covered Buildings
- 4 PROTECTION AGAINST PROPAGATION
 - 4.1 Introduction
 - 4.2 HD 1.1
 - 4.3 HD 1.2
 - 4.4 HD 1.3
 - 4.5 HD 1.4, HD 1.5 and HD 1.6
- 5 HAZARDS TO PERSONNEL
 - 5.1 Blast
 - 5.2 Fragments
 - 5.3 Injuries – HD 1.1
 - 5.4 Injuries – HD 1.2
 - 5.5 Injuries – HD 1.3
 - 5.6 Building Damage Levels at Exposed Sites
- 6 TYPES OF EXPLOSIVES FACILITIES
 - 6.1 Introduction
 - 6.2 Light Structure
 - 6.3 Medium-Walled Building
 - 6.4 Heavy-Walled Building
 - 6.5 Earth Covered Buildings
 - 6.6 Igloo
 - 6.7 Open Bay or Site (Traversed or Untraversed)
 - 6.8 Process Building
 - 6.9 Storage in ISO or similar Containers
- 7 INHABITED AND NON-INHABITED NON-EXPLOSIVES BUILDINGS –
RELATIONSHIP WITH PES
 - 7.1 Inhabited Buildings

8 VULNERABLE CONSTRUCTION AND LARGE FACILITIES

- 8.1 Vulnerable Construction
- 8.2 Large Facilities of Special Construction or Importance
- 8.3 Non-inhabited Buildings

9 GENERAL DESIGN CONSIDERATIONS AND CONSTRUCTIONAL REQUIREMENTS OF EXPLOSIVES FACILITIES

- 9.1 General
- 9.2 Design Fundamentals for Protective Buildings
- 9.3 Pressure Release
- 9.4 Frangible Materials
- 9.5 Rocket and Missile Storage Facilities
- 9.6 Storage of HD 1.1 Shaped Charge Warheads
- 9.7 Construction to Contain Fragments and Prevent Lobbing
- 9.8 Construction to give Protection Against Projectiles

10 SPECIFIC CONSTRUCTIONAL REQUIREMENTS

- 10.1 Structural Reinforced Concrete
- 10.2 Structural Steel Components (including Structural Purlins)
- 10.3 Brickwork
- 10.4 Other Construction Materials
- 10.5 Roofs
- 10.6 Floors
- 10.7 External and Internal Walls - Finish
- 10.8 Drainage
- 10.9 Doors
- 10.10 Glazing
- 10.11 Hatches
- 10.12 Ventilation and Air Conditioning
- 10.13 Dust Extraction Systems
- 10.14 Heating
- 10.15 Lighting and Other Electrical Installations
- 10.16 Building Services
- 10.17 Lightning Protection System (LPS)
- 10.18 Bonding of Metal
- 10.19 Precautions Against Static Electricity
- 10.20 Earthing Requirements
- 10.21 Conducting and Anti-Static Floors or Mats
- 10.22 Lifting Appliances
- 10.23 Security
- 10.24 Fire Protection Measures

11 BLAST DESIGN METHODS AND VALIDATION

- 11.1 Blast Design
- 11.2 Blast Design Calculations
- 11.3 Designs and their Retention
- 11.4 Approval of Designs

Tables

- 1 Indication of Blast Pressure at which Injury Will Occur
- 2 Construction Requirements for ES
- 3 Minimum Construction Requirements for Exposed Sites (ES) Doors

Annex

A Standard Buildings for Military Explosives

1 BUILDINGS ASSOCIATED WITH MILITARY EXPLOSIVES

1.1 Introduction

1.1.1 Most Potential Explosion Sites (PES) are a potential hazard to personnel, other explosives facilities, and other buildings that are in the vicinity. This chapter gives guidance on the mandatory requirements for the design of buildings containing explosives such that:

- (1) At a PES, initiation of, and/or damage to, the contents of adjacent explosive facilities can be prevented by intercepting high velocity fragments and debris and reducing blast and thermal effects.
- (2) At an Exposed Site (ES), initiation of, and/or damage to the contents can be prevented and injury to personnel minimised by structural resistance to blast, thermal effects, high velocity fragments and debris, and lobbed items. Ground shock is normally only a problem close in or associated with shared earth cover.
- (3) In Process Buildings, personnel can be reasonably protected from the effects of a nearby explosive event, as well as from the potential hazards from the explosives being processed at an adjacent work station.

1.1.2 Correct building design, construction and siting is essential in order to make effective use of the Quantity Distances (QDs). It is also important to note that an ES such as an igloo, built to withstand a large external explosive event, may prove to be a serious hazard when subjected to an internal accidental explosion. Additionally, PES of light construction will generate a low building debris hazard to personnel outside, but, as an ES, will offer little protection to personnel inside from building debris from a nearby PES event.

2 CONSEQUENCES OF AN EXPLOSIVE EVENT

2.1 Hazards to be Protected Against

2.1.1 The hazards that stored explosives require to be protected against to avoid propagation/initiation are:

- (1) Blast. The air blast from an explosion involving HD 1.1 is in the form of a pressure increase or shock front which expands radially from the centre of the explosion at supersonic velocity. When this shock front impinges on a rigid object such as a building, a higher pressure is produced due to reflection of the wave. As the wave expands from the explosion, it decays in strength, lengthens in duration and decreases in velocity. In addition to the shock wave for each pressure range, a particle or wind velocity is produced by the shock front that causes a dynamic pressure on objects in its path. In the free field, these pressures are functions of the air density and particle velocity.
- (2) Ground Shock. When an explosion of HD 1.1 occurs at or near the ground surface, shock loading results from the energy that is imparted to the ground surface. Some of this energy is transmitted through the air to form air-induced ground shock, and some through the ground as direct-induced ground shock. Air-induced ground shock occurs when the air blast shock wave strikes the ground surface and sends a stress impulse into the underlying medium. Direct-induced ground shock results from the explosives energy being transmitted directly through the ground. The net ground shock experienced is a combination of the two. The relative magnitude and motion sequence are functions of the medium (soil type and air) through which the shock travels, at the distance from the point of detonation. Usually, the effects of ground

shock are small compared with air blast. However, for some explosions particularly those sub-surface, this may not be the case.

(3) Fire and Thermal Radiation. Detonation of explosives results in the production of a fireball. Normally, for explosives of HD 1.1, the radiation from the short-lived flame is of negligible hazard in comparison with blast and fragment effects. Explosives of HD 1.3 differ from detonating explosives of HD 1.1, in that, unless heavily confined, their reaction does not result in the generation of high-pressure gases. The energy per unit mass of HD 1.3 explosives is comparable with that of a detonating explosive, but whereas the energy of a detonating explosive is released within a few milliseconds, that from an unconfined propellant is released over a period measured in seconds. This energy is released in the form of an intense flame and may cause hazard by the direct impingement of the flame and by thermal radiation.

(4) Debris and Fragments. These may be:

(a) Primary fragments from the casings of explosive articles. Typically, they may have velocities of up to 3000 ms^{-1} and weigh from 1 g to 500 g. Such fragments can kill or injure personnel and initiate adjacent explosives if of sufficient energy.

(b) Secondary debris from packaging and structural materials, including earth from traverses or cover, arising from the break-up of the PES. These have much lower velocity than primary fragments, typically from 10 ms^{-1} to 500 ms^{-1} but could kill or injure personnel and even initiate adjacent explosives if of sufficient energy. Debris projection is not constant but shows a marked directional effect. Less debris is projected from the corners of a structure, increasing to a maximum normal to each face of the structure. This is repeated on all sides of the structure irrespective of whether a traverse is present; this effect should be taken into account when siting ES relative to PES.

(c) Secondary debris from material thrown from the crater formed by an explosive event. This has no directional effects and normally has a low velocity but could present an impact hazard to personnel and may even initiate adjacent explosives if of sufficient energy.

2.1.2 The sensitivity to blast over-pressure, structural motion, fire and impact by fragments differs markedly with the type of explosives stored. Except where extremely high over-pressures occur, most explosives are insensitive to the effect of blast over-pressure. However, blast over-pressure and structural motion could cause translation of explosives which may result in impact and subsequent initiation.

2.1.3 Generally, attack by primary fragments is considered to be the main cause of initiation of explosives at an ES, although explosive substances or light cased explosive articles could be initiated by debris or spalling.

2.1.4 The extent of the hazard to explosives at an ES will therefore depend on the ability of the ES structure to resist blast loading without extensive deformation, and generally, without fragment penetration. The primary design objective must be to prevent destruction or collapse of the structure and to introduce measures to prevent spalling from the internal faces.

2.2 Projection Hazards – All PES Types

2.2.1 The projection hazard from a PES cannot be easily related to the scaled distance for blast effects. However, for all practical purposes, there is likely to be a hazard from projections at all scaled distances less than twice the Inhabited Building Distance (2 x

22.2Q^{1/3}), the hazard being greater when the PES is not traversed. Unless the exposed site has been provided with protection against all projections, including high angle missiles, the minimum distances must be applied.

3 QUANTITY DISTANCES FOR AIR-BLAST EFFECTS

3.1 Introduction

3.1.1 The blast overpressure effects to be expected at a given scaled distance can be predicted with a high degree of confidence. The technique is well developed, and the effects of blast may be treated deterministically.

3.2 Open Stacks and Light Structures

3.2.1 It can be assumed that the blast overpressure from a light structure is the same as that to be expected from a bare charge. This assumption is especially true as the scaled distance increases. The following QD are considered:

QD (Q in kg, D in m)	Peak Incident (Side-on) Overpressure Expected (kPa)
44.4Q ^{1/3}	1.5
22.2Q ^{1/3}	5
14.8Q ^{1/3}	9
8.0Q ^{1/3}	21
3.6Q ^{1/3}	80
2.4Q ^{1/3}	190

3.3 Earth-Covered Buildings

3.3.1 The earth cover of earth-covered buildings will generally attenuate the blast overpressure. The greatest reduction will be obtained from the rear of the building. The following QDs are considered for such buildings, containing up to 250 000 kg NEQ, defined as UK standard igloos:

Direction	QD (Q in kg, D in m)	Peak Incident (Side-on) Overpressure Expected (kPa)
Side	19.0Q ^{1/3}	5
Rear	15.5Q ^{1/3}	5
Side	14.0Q ^{1/3}	8
Rear	11.0Q ^{1/3}	9
Rear	6.0Q ^{1/3}	21

4 PROTECTION AGAINST PROPAGATION

4.1 Introduction

4.1.1 The protection of explosives at an ES from the effects of an explosion is achieved by the provision of adequate separation distances between facilities, and the use of buildings designed to protect the contents from the hazardous output of the explosion. The separation distance is required to attenuate the effects of the blast, fragments and heat radiation to a level which will make the construction of a protective structure at the ES feasible and cost effective.

4.1.2 To provide maximum protection, structures at an ES should be either strong enough to withstand the output of the explosion, or light enough so that collapse and any debris formed will not initiate the contents. Buildings should preferably be able to resist the blast loading without extensive deformation and fragmentation penetration.

4.2 HD 1.1

4.2.1 The protection against propagation of explosives in open stacks is achieved by the provision of adequate Quantity Distances (QDs) between facilities, and by the use of effective traverses. The QDs are intended to attenuate the effects of blast, fragments and radiated heat to levels at which propagation should not occur.

4.2.2 Traverses intercept high velocity fragments and either arrest them or reduce their velocity to levels below which propagation should not occur. When subjected to blast loading, a traverse must remain substantially intact for a sufficient length of time to enable the interception of fragments to be achieved.

4.2.3 The unitization of explosives in a PES using suitable internal walls or traversing enables reduced QDs to be used based on the largest quantity of explosives in an individual compartment instead of the total amount in the whole PES. The function of the dividing walls/internal traverses is to prevent, or at least substantially delay, the communication of an explosion between explosives on opposite side of the wall/traverse. Provided that the amount of explosives is small enough, adequate container traverses can be designed to arrest most high velocity fragments.

4.2.4 Explosives buildings constructed from masonry, mass concrete, timber, etc, are not suited to resist blast loading. These materials are not ductile and sudden failure under load is likely to occur. This mode of failure will also be a source of structural debris that may initiate the explosives stored within.

4.2.5 Reinforced Concrete (RC) structures are specifically designed to provide a level of protection against the most onerous blast hazard that might occur. They also prevent explosives and/or personnel within from being subjected to fragment and debris hazard and attenuate the blast over-pressures to levels where damage/injury should not occur.

4.3 HD 1.2

4.3.1 By their nature explosives of HD 1.2 will not sustain propagation. Therefore, normal construction materials such as concrete, brick and earth-covered structures will be satisfactory for the construction of storehouses for HD 1.2. However timber and lightweight steel doors are not resistant to projection effects and should not normally be used.

4.4 HD 1.3

4.4.1 The thermal radiation from the fireball produced by explosives in HD 1.3 is capable of communicating the fire to another facility and the explosives within. High winds will deflect the upper parts of a fireball away from the seat of the fire, perhaps moving it closer to an ES. Additionally, weak points in a PES structure may cause jetting of the fireball.

4.4.2 Normal construction materials such as concrete and brick, and earth-covered structures can be assumed to be impervious to thermal radiation and flame impingement from fires involving HD 1.3. However, timber and lightweight steel doors are not resistant to the effects of fire and should not normally be used.

4.5 HD 1.4, HD 1.5 and HD 1.6

4.5.1 Any secure, weather-proof structure may be used to store explosives of HD 1.4. For HD 1.5 and HD 1.6, advice should be sought from DIO and DOSR through the appropriate IE.

5 HAZARDS TO PERSONNEL

5.1 Blast

5.1.1 Human tolerance to blast is relatively high, and the degree of injury will be proportional to the amount of over-pressure sustained. The orientation of a person and the shape of the shock front are significant factors in determining the injuries sustained. The release of air bubbles from disrupted alveoli of the lungs into the vascular system probably accounts for most fatalities. The rupture of eardrums and injury to the body due to translation are also likely to be sustained.

5.2 Fragments

5.2.1 Fragments and debris are considered potentially lethal if their energy at impact is 80 joules or more. Generally, it is expected that, at the Inhabited Building Distance the density of such lethal fragments will not exceed 1 per 56m² on the ground surface.

5.3 Injuries – HD 1.1

5.3.1 Table 1 gives an indication of the blast pressures at which personnel injury levels will occur.

Serial No	Injury Level	Maximum Blast Pressure
		kPa
1	<u>Eardrum Rupture</u> Threshold 50% Rupture	35 100
2	<u>Lung Damage</u> <u>Threshold</u> <u>50% Lethality</u>	70 250
3	<u>Body Translation</u> Threshold of Lethality 50% Lethality	100-150 400-750

TABLE 1 INDICATION OF BLAST PRESSURE AT WHICH INJURY WILL OCCUR

5.3.2 The expected injuries to personnel at specific QDs from explosives of HD 1.1 are as follows:

- (1) $QD\ 8.0Q^{1/3}$ (Process Building Distance) Serious injuries or possible fatalities are likely from debris, firebrands, fragments, or building collapse. There is only a small chance of serious injury occurring due to direct blast effects.
- (2) $QD\ 14.8Q^{1/3}$ (Public Traffic Route Distance):
 - (a) Personnel in the open are not likely to be seriously injured by blast, but some injuries are likely due to fragments and debris, the extent of which will depend on the construction of the PES.
 - (b) Personnel in a building will be afforded a high degree of protection from death or serious injury. Any injuries that do occur will be caused mainly by fragments from glass breakage and building debris.
- (3) $QD\ 22.2Q^{1/3}$ (Inhabited Building Distance). Injuries are unlikely as a direct result of blast effects but could occur due to glazing fragments and flying/falling debris.

(4) QD 44.4Q^{1/3} (Vulnerable Building Distance). Injuries are unlikely as a direct result of blast effects. Injuries that do occur will be caused principally by falling glass.

5.4 Injuries - HD 1.2

5.4.1 For explosives of HD 1.2, the total fragment/debris hazard at IBD would not be expected to exceed one potentially lethal fragment (>80j) per 56m² of ground area at the surface. It should be noted that the hazard is generated over a significant time period, generally in excess of one hour after the initial explosive event and is not generated instantaneously as in the case of HD 1.1.

5.5 Injuries – HD 1.3

5.5.1 For explosives of HD 1.3, the IBD is based on a thermal dose criterion of 62.8 kJ/m². It is anticipated that occupants of traditional UK types of inhabited buildings would not suffer injury unless standing in front of a window. Such personnel, and any personnel in the open, are likely to experience reddening of any exposed skin areas.

5.6 Building Damage Levels at Exposed Sites

5.6.1 The damage levels likely to occur to an ES of conventional construction from an explosion of HD 1.1 at a PES for different QDs are as follows:

- (1) QD 2.4Q^{1/3} Buildings not designed to resist the blast loading will almost certainly suffer complete demolition.
- (2) QD 8.0Q^{1/3} (PBD) Buildings not designed to resist the blast loading will probably suffer severe damage. Direct initiation of stored explosives is unlikely, but communication of the explosion as a result of fire could occur.
- (3) QD 22.2Q^{1/3} (IBD) Buildings not designed to resist the blast loading should suffer only minor damage, mainly to glazing, lightweight cladding, etc.
- (4) QD 44.4Q^{1/3} (Vulnerable Building Distance (VBD)) Buildings not designed to resist the blast loading are likely to suffer only superficial damage to large panes of glass and other lightweight cladding.

Vulnerable constructions (see para 8.1) located between IBD and 2 x IBD (i.e. Vulnerable Building Distance) may be damaged by an explosion. A structural assessment of the extent of the damage that would occur, including the possibility of collapse and fragment or debris penetration, must be made. Vulnerable buildings located beyond 2 x IBD should not be damaged and therefore do not require assessment.

6 TYPES OF EXPLOSIVES FACILITIES

6.1 Introduction

6.1.1 The design and construction of all explosives buildings shall be in accordance with all current regulations, British Standards and Codes of Practice.

6.2 Light Structure

6.2.1 Light structured buildings are those constructed of light frangible materials that will not produce dangerous projections when used as a PES. As an ES, this structure could collapse, but the debris produced should not initiate explosives or seriously injure personnel within. This type of structure is typically a single-storey building, clad with lightweight steel, aluminium or GRP sheeting or similar materials. Doors must comply with Table 3.

6.2.2 A light structure provides little resistance to high velocity fragments, lobbed munitions and debris from a HD1.1/HD1.2 explosive event, and from the fire hazard of a HD1.3 event. As an ES, light structures should be traversed to reduce IQD but must be traversed where used as a Process Building. The use of a screening traverse can reduce the IBD from a light structure PES. This traverse must be high enough to intercept all missiles projected at 40° or less.

6.3 Medium-Walled Building

6.3.1 A medium-walled building is one constructed of a nominal thickness of 215 mm solid or 280 mm cavity masonry walls or 150 mm reinforced concrete (RC) and a 150 mm (RC) roof slab. Doors must comply with Table 3. As an ES, this type of structure could collapse and damage stocks as it is not normally designed to resist blast over-pressures. The debris produced by a PES (dependent on the quantity of explosives involved) could have a high enough velocity to initiate explosives or seriously injure personnel within the ES. This type of building will not resist the penetration of high velocity fragments at an ES or PES and should be traversed to reduce IQD.

6.3.2 A medium walled building is reasonably effective in resisting fragments and lobbed items of HD 1.2 explosives and provides adequate protection against the fire hazard from HD 1.3 explosives. The use of a screening traverse can reduce the IBD from a medium-walled structure as a PES. This traverse must be high enough to intercept all missiles projected at 40° or less.

6.4 Heavy-Walled Building

6.4.1 A heavy-walled building is one with a nominal 680 mm thick masonry or 450 mm thick concrete walls, and a minimum 150 mm RC roof. Doors must comply with Table 3. A receptor traverse is not generally required as the heavy walls fulfil this function. However, if the stocks are vulnerable to attack by debris, a separate traverse is to be provided and consideration should be given to increasing the strength of the roof to prevent perforation and back-face spalling. Where the building doors are exposed to fragments from a PES, they are to be shielded by a traverse. As an ES this type of building will:

- (1) Prevent initiation of explosives within by resisting the penetration of high velocity fragments but could collapse and damage stocks as it is not normally designed to resist blast.
 - (2) Be effective in resisting incoming fragments and lobbed munitions from HD 1.2 explosives, but only when the roof is constructed from RC.
 - (3) Provide adequate protection against the fire hazard from HD 1.3 explosives.
- 6.4.2 As a PES, the building may intercept some or all of the high velocity primary fragments, but the amount of debris is increased by the nature of its construction.

6.5 Earth Covered Buildings

6.5.1 An earth covered building is any structure (except an igloo, see below) which has a minimum thickness of 600 mm of earth on the roof, and earth cover to the sides and rear walls. Doors must comply with Table 3. The slope of the earth against the walls is dependent on the material used. A traverse is to be provided to shield those doors and walls that are not earth covered and which face a PES. As an ES, this type of building behaves similarly to a heavy-walled building for all hazard divisions.

6.6 Igloo

6.6.1 An igloo is an explosives storehouse with earth cover as described in para 6.5.1 above. The structure and doors have been specifically designed to resist blast and high velocity fragments so that the contents will not be initiated or seriously damaged at the required IMD. The supporting structure for the earth cover can be constructed of corrugated steel and RC, but is normally an RC box structure.

6.6.2 As an ES, this type of building behaves similarly to an earth covered building with the additional advantage of having been designed to resist the blast loading and therefore giving stored explosives complete protection from initiation at reduced IMD. The doors and headwall do not normally require a traverse providing they have been designed to resist the blast loading and high velocity fragment penetration. As a PES, an igloo attracts reduced QDs due to attenuation of the blast by the earth cover. In order to gain the most efficient land usage where more than one igloo is used, igloos should be orientated side-by-side with the headwalls on a common line. Where more than one row of igloos is used, the front walls in one row should face the rear of the other igloos in the second row.

6.7 Open Bay or Site (Traversed or Untraversed)

6.7.1 The floor of such a bay or site is preferably to be of concrete with any required battens firmly attached. Consolidated hard-core or other suitable material may be used, but this form of a base will require constant maintenance to keep vegetation under control and in a usable condition. Traverses may or may not be required.

6.8 Process Building

6.8.1 A Process Building (PB) is a building or site in which explosives are manufactured or worked upon. This includes such facilities as missile test rooms, preparation buildings, explosives workshops and DPA laboratories. 'Work' includes all maintenance and preparation procedures.

6.8.2 Under Health & Safety at Work Legislation, MOD has a duty-of-care to protect workers and to lower the risk to that which is both tolerable and ALARP.

6.8.3 As an ES, this type of building must either be designed to survive and protect workers from an explosion at a PES or have a relatively large separation distance from other PES in order to give protection to personnel rather than just to protect against initiation of the explosives contained within.

6.8.4 As a PES, a PB is classified according to its construction and the QDs determined using the total quantity of explosive that may be present at any one time unless effectively utilised. Due to the close proximity of explosives to workers within a PES, it may not be possible (other than for small quantities of explosives) to provide protection, and fatalities would be expected. Nonetheless, the ALARP principle must still be applied wherever reasonable and practicable to lessen the risk.

6.9 Storage in ISO or Similar Containers

6.9.1 An ISO Container, or similar transport container, is to be treated as an open stack when being used for storage of explosives.

7 INHABITED AND NON-INHABITED NON-EXPLOSIVES BUILDINGS – RELATIONSHIP WITH PES

7.1 Inhabited Buildings

7.1.1 Inhabited buildings are those which contain personnel but not explosives. The term is usually applied to buildings used by the general public outside an explosives area, but is also used for those buildings inside the MOD boundary that may be affected by a PES, e.g. Married Quarters, administration areas, etc. All non-explosives inhabited buildings within the IBD of a PES must be designed to resist the expected blast over-pressure and should resist fragments and debris. However, and unusually, where the risk from fragments is low, a Light Structure that would collapse and produce debris that would not seriously injure personnel within may provide a cost-effective alternative.

7.1.2 The glazing in inhabited buildings is vulnerable to the effects of a blast even at a distance of 2 x IBD (viz purple line) where there is still some risk of injury from flying or falling glass. Construction and glazing of inhabited buildings affected by a PES must comply, as a minimum, with Table 2.

Table 2 Construction Requirements for Exposed Sites				
Distance from PES		Structural Requirements	Glazing Requirements	Notes
Quantity	Description			
$\geq 44.4 Q^{1/3}$	Vulnerable Building Distance (Purple Line)	Conventional Design only	MOD Standard Glazing: "Normal"	
$< 44.4 Q^{1/3}$		Conventional Design only. Buildings of Vulnerable Construction not permitted. See Chapters 6 & 10 Loadbearing brick structures acceptable subject to JSP440 requirements for limitation of progressive collapse	Either single glazed or double-glazed options. Both laminated glass and anti-shatter film acceptable.	
$22.2 Q^{1/3}$	Inhabited Building Distance			
$\geq 16 Q^{1/3}$	Closest Indirect Support Distance (Unhardened)			
$< 16 Q^{1/3}$		Conventional Design, but must include a reinforced concrete slab at roof level, minimum thickness 150mm	MOD Standard Glazing: "Normal"	
$\geq 14.8 Q^{1/3}$	Public Traffic Route Distance			
$< 14.8 Q^{1/3}$		Conventional Design, but must include a full structural frame and a reinforced concrete slab at roof level, minimum thickness 150mm	Either single glazed or double-glazed options. Laminated glass acceptable. Anti-shatter film unacceptable.	
$\geq 11.1 Q^{1/3}$	One-half Inhabited Building Distance			
$< 11.1 Q^{1/3}$		Either an DOSR approved Type Design or Specialist Blast Design to protect occupants Contact DOSR	MOD Standard Glazing: "Enhanced"	
$\geq 9.6 Q^{1/3}$	Closest Direct Support Distance (Unhardened)			
$< 9.6 Q^{1/3}$		Specialist Blast Design Contact DOSR	MOD Standard Glazing: "Special"	
$\geq 8 Q^{1/3}$	Process Building Distance			
$< 8 Q^{1/3}$	Special Facilities			Windows should not face a PES, or must be effectively traversed

8 VULNERABLE CONSTRUCTION AND LARGE FACILITIES

8.1 Vulnerable Construction

8.1.1 Serious structural damage, caused by blast, to traditionally constructed low-rise buildings located between IBD and 2 x IBD (i.e. Yellow and Purple Lines - see Definitions) should not occur. The breakage of glass and frangible cladding could occur, but the risk of serious hazard to occupants should be minimal.

8.1.2 Certain types of construction are known to be susceptible to significant damage at and beyond IBD and may therefore cause injuries and fatalities disproportionate to the scale of the event; this may result either from materials used (e.g. extensive glazed areas) or from the risk of global collapse which could crush and kill occupants who would otherwise be expected to survive in the open or in more traditional forms of construction. The term 'Vulnerable Construction' is used to describe these types of building and require special attention.

8.1.3 Whilst buildings of vulnerable construction are normally to be sited at a minimum of $44.4Q^{1/3}$, the variation and complexity of modern building materials and construction methods, together with the need to consider usage and population, make it impossible to define universal regulations. A building classified as vulnerable may still be located at the normal IBD if the population is low or measures are taken to protect the population from the potential explosion hazards.

8.1.4 Guidance to the types of building that might be described as being of Vulnerable Construction, and the factors that will influence the need to locate them outside the Purple Line from a PES are as follows:

- (1) Type 1 - Glazed or Other Frangible Curtain Wall Construction - Buildings that are more than three storeys or 12 m in height constructed with continuous non-load bearing curtain walling with individual glazed or frangible panels larger than 1.5 m² and extending over more than 50% or 120 m² of the surface of any elevation. This construction is typical of that used in high rise office buildings.
- (2) Type 2 - Glazed Wall Construction - Buildings that are more than three storeys or 12 m in height with solid walls and individual glazing panes or frangible panels larger than 1.5 m² and extending over at least 50% or 120 m² of any elevation. This construction is also typical of that used in high rise office buildings.
- (3) Type 3 - Glazed or Other Frangible Roof Construction - Buildings that are of more than 400 m² plan area with continuous or individual glazing panes larger than 1.5 m² extending over at least 50% or 120 m² of any elevation. Type 3 buildings encompass the kind of construction typical of that used in covered market buildings, shopping complexes and retail warehouses.
- (4) Type 4 - Sensitive Structures Building structures that may in themselves be susceptible to disproportionate damage (e.g. collapse, partial collapse or progressive collapse), including:
 - (a) unframed structures with limited continuity utilising non-ductile materials;
 - (b) large-span, tension or other special structures with critical load bearing elements;
 - (c) unusually weak structures (typically historic or timber framed buildings);

- (d) buildings containing vulnerable elements such as pre-cast panel fixings or large span slender masonry panels which may be particularly susceptible to failure and lead to a falling debris hazard.

8.1.5 As a general guide, buildings that stand out either dimensionally or by construction type against a normal background of houses should be subject to closer examination. Cases that fall within or near the vulnerable construction guide-lines above, or where it is suspected that they may be particularly vulnerable to blast, require an assessment of the potential risks and further guidance should be sought from TA (Structures) and DOSR through the appropriate IE.

8.2 Large Facilities of Special Construction or Importance

8.2.1 Where such facilities are not assessed to contain Vulnerable Construction, a Technical Assessment must be carried out for each site.

8.2.2 Where the facilities are assessed to contain Vulnerable Construction, the large facilities are, without exception, to be sited at a minimum QD of $44.4Q^{1/3}$.

8.3 Non-Inhabited Buildings

8.3.1 The construction of buildings in an explosives area which are normally unmanned, such as Plant Rooms, Sub-stations, pump houses etc, should be commensurate with the importance attached to the survival of the facility.

9 GENERAL DESIGN CONSIDERATIONS AND CONSTRUCTIONAL REQUIREMENTS OF EXPLOSIVES FACILITIES

9.1 General

9.1.1 Explosives facilities are to be constructed so as to provide a specified level of protection against the hazards of accidental explosive events in another facility. The type of structure provided will depend on the protection level required and/or the type and quantity of explosives stored. Confinement of an explosion within a 'strong' structure would have a marked effect on the structure and hazards produced when compared with an unconfined event in a 'weak' (frangible) structure.

9.1.2 The structural form of the facility will be dictated by the blast loading acting on the structure. Additionally, fragment/debris distribution will determine whether the roof and walls are reinforced and/or whether protection provided by means of an approved traverse is required. In general, buildings at an ES subjected to high blast loadings should be constructed of reinforced concrete and be earth covered. For PES with smaller quantities (up to approximately 1000kg HD1.1) the earth cover may be omitted.

9.1.3 Facilities are to be designed so that they are easy to keep clean and dirt and dust are minimised. Adequate access to the facility should be provided to enable movement of the explosives contents. Where possible, fixtures and fittings are to be positioned so that they cannot be fouled by MHE or by other equipment. Where this is not possible, fixtures and fittings are to be suitably protected.

9.1.4 There is to be sufficient space on all four sides of an explosives stack for inspection of the contents. An appropriate gangway is to be provided between stacks and the wall of an explosives storehouse. This gangway should be permanently marked on the floor as a sterile area using yellow hatched markings.

9.1.5 All explosives storehouses should be designed and equipped such that the inside temperature neither falls below 5°C, nor rises above 25°C. If the stipulated temperature

conditions cannot be sustained, artificial heating/air conditioning to an approved standard is to be installed.

9.1.6 The surrounding site must be free of flammable materials and undergrowth shall be kept close cropped to the ground. Grass shall be kept very short up to 9m from PES. Shrubs, which do not present an undue fire hazard, are permitted inside this distance. The rest of the site must be kept in such a condition so as not to present an undue fire risk.

9.2 Design Fundamentals for Protective Buildings

9.2.1 Where facilities are required to provide protection to personnel (e.g. Process Buildings and/or other occupied buildings at IQD) the buildings must be designed to resist blast loadings and perforation by projections. The following shall apply:

- (1) Design considerations shall be based on a 90% confidence level
- (2) Deflections of main supporting structural elements shall be limited to 2° support rotations or deflections of span/60. If mild-steel spall plates of adequate thickness are fixed to the internal face of RC surfaces to retain back-face spalling, maximum support rotation of 4° or deflections of span/30 may be adopted.
- (3) High velocity spalling of RC elements or members is not permitted or is to be prevented by the use of spall plates. Low velocity spalling may be accepted if it can be adequately demonstrated that it will not be unreasonably injurious to personnel.
- (4) The glazing hazard shall be no more than Low Hazard.

9.3 Pressure Release

9.3.1 The design of structures to fully contain the blast and fragments due to an internal explosive event is only practicable when very low quantities (typically ≤ 10 kg) of explosives of HD 1.1, or larger quantities (typically ≤ 50 kg) of HD 1.3 are stored. Structures designed to store explosives of HD 1.3, or small quantities (typically ≤ 100 kg) of HD 1.1, can be designed to survive with limited damage by incorporating a frangible wall/panel to reduce the magnitude and duration of the internal blast parameters that will occur when this type of explosives is initiated. Each case is likely to be different and specific advice should be sought from DOSR through the responsible IE.

9.4 Frangible Materials

9.4.1 The ideal frangible material should be of low mass, break up into small harmless fragments at the PES, and be strong enough to resist fragments as an ES. The provision of a traverse to shield a vent panel against fragment attack would avoid the need for the material to be fragment resistant at an ES. However, the frangible wall/panel must meet the security requirements laid down in JSP 440; this may be best achieved by using a separate and approved security barset inside the vent panel which does not compromise the vent operation and has a further advantage of improving resistance to external blast pressures. Restriction of gas flow through the reduced vent area must be taken into account in the design.

9.4.2 The frangibility of a material, in addition to being dependent on the strength and mass of the material used, is also a function of the applied blast loading. As the blast loading on the panel in typical storage situations is likely to be very large in comparison with the resistance of the element, the effects of resistance can often be neglected, and the frangibility determined by considering the unit mass of the panel only. For small quantities this is not the case, and consideration of the resistance function in accordance with UFC 3-340-02 'STRUCTURES TO RESIST THE EFFECTS OF ACCIDENTAL EXPLOSIONS' may

be necessary. To allow adequate venting, a frangible wall/panel is to have a mass not exceeding 50 kgm⁻² for HD 1.3 and 25 kgm⁻² for HD 1.1. A line of sight must not exist between frangible walls in adjacent PES unless the separation distance is sufficient to prevent propagation by fragments, debris or projected burning propellant.

9.4.3 The fixings used to secure the frangible walls/panels to the structure are to be designed such that the frangible portion fails in the required manner. The suitability of materials used in the construction of frangible features will depend on factors such as mass, durability and weather resistance. Typical frangible materials used in order of preference are:

- (1) Glass Reinforced Plastic (GRP). This is a high strength material that produces small lightweight projections of low velocity and is preferred for typical situations. The unit mass is 2.2 kgm⁻² per mm thickness.
- (2) Plywood. This material has a high strength to weight ratio, but sections greater than 25 mm thick may produce heavy, sharp fragments. The unit mass is ~ 0.6 kgm⁻² per mm thickness.
- (3) Fibrous Cement Sheeting. This material is lightweight and strong but produces sharp fragments that could be hazardous. The unit mass is 2.5 kgm⁻² to 3.3 kgm⁻² per mm thickness.
- (4) Steel and Aluminium Sheeting. These materials both have a low mass and high strength and tend not to break up. They are therefore likely to produce a more hazardous projection risk. The unit mass is 2.7 kgm⁻² per mm thickness for aluminium and 7.8 kgm⁻² per mm for steel.
- (5) Proprietary Lightweight Panels. These are composite panels consisting of thin metal sheeting with a lightweight insulating core such as Styrofoam. This type of material has a low mass and would easily be removed from its fixings by a blast. They tend not to disintegrate and may give an unacceptable projection hazard risk. The individual properties of this type of panel should be sought from the prospective manufacturer.
- (6) Glass. Glass has excellent frangibility but produces extremely dangerous fragments that may cause serious injury to nearby personnel. The unit mass is 1.2 kgm⁻² per mm thickness.

9.4.4 Typical frangible panels are illustrated at Annex A, Appendix 3.

9.5 Rocket and Missile Storage Facilities

9.5.1 Unless tests have been conducted to prove otherwise, all rockets and missiles are to be regarded as self-propulsive. Facilities used for the storage of rockets or missiles that are in a propulsive state are to have walls thick enough to prevent their perforation in the event of accidental initiation. Alternatively, the rockets/missiles are to be adequately secured to the structure.

9.5.2 As an alternative to designing a structure to resist the rocket motor thrust, a vertically faced traverse, located as close to the building as possible, should be provided. This traverse must be thick enough to prevent perforation by the rockets. The traverse length and height must subtend an angle of 10° from the door aperture.

9.5.3 The most suitable type of structure for storage of propulsive rockets is an igloo, with the rockets positioned so as to point towards the rear or sidewalls. Unless the missiles face the door, no door traverse is required.

9.5.4 Rockets in a non-propulsive state should be stored in structures suitable for the quantity and HD of the explosives present.

9.6 Storage of HD 1.1 Shaped Charge Warheads

9.6.1 Investigations have indicated that shaped charge warheads will generate a shaped charge if they are caused to initiate, even in a fire. The jet thus formed will be significantly less efficient than the designed effect but will still be capable of penetrating the walls of any storage structure. To mitigate these effects, the warheads should be pointed towards earth backed walls. It is preferable to have several discrete layers, e.g. cavity walls with a vertical faced and earth backed traverse, between the stored warheads and the free field, as this will help to disrupt the jet. Obviously the larger the shaped charge, the more penetrative any formed jet will be and the more difficult it will be to provide effective mitigation.

9.6.2 No specific QDs are recommended to provide protection against the shaped charge effect, even from very large charges, since the jet represents only one fragment. Therefore, provided the recommendations are followed, conventional HD 1.1 QDs may be applied for licensing purposes.

9.7 Construction to Contain Fragments and Prevent Lobbing

9.7.1 The design of structures to contain projections or lobbed items of HD 1.1 is an extremely complicated procedure and, unless warranted by special circumstances, is prohibitive in cost.

9.7.2 In practice, it is generally only feasible to design such a structure when the NEQ is small, or when the NEQ is divided into smaller quantities by dividing walls that prevent the mass explosion of the entire content in the event of an accidental explosion in one of the units. The design of a structure to contain projections and lobbed items represents a more stringent requirement than that for dividing walls to prevent propagation. Where such a design is required, advice must be sought from TA (Structures).

9.8 Construction to Give Protection Against Projectiles

9.8.1 Explosives buildings should be constructed to give protection against perforation by debris, low velocity fragments and lobbed munitions. This is achieved by providing appropriate separation distances and the minimum construction thicknesses listed below:

- (1) Roof - 150mm in-situ reinforced concrete slab.
- (2) Walls - 150mm in-situ reinforced concrete or 215mm nominal solid brickwork.
- (3) Doors - 16mm mild steel or equivalent

9.8.2 To give protection against high velocity fragments, a traverse or earth cover should preferably be provided. However, if this is not possible, the following material thicknesses will generally be sufficient to prevent initiation of the explosives at an ES:

- (1) Walls - 450mm in-situ reinforced concrete or 680mm nominal solid brickwork
- (2) Doors - 50mm mild steel or equivalent
- (3) Traverse - 2400mm of earth

10 SPECIFIC CONSTRUCTIONAL REQUIREMENTS

10.1 Structural Reinforced Concrete

10.1.1 The lowest grade of concrete permitted for use in construction of explosives facilities is C35 with a nominal maximum aggregate size of 20 mm (BS 8110 – Structural Use of Concrete refers).

10.1.2 For conventional structures used as explosives buildings, the normal reinforcement requirements in BS8110 apply. Where there is a design requirement to consider dynamic loads, the following will also apply:

- (1) The arrangement and quantity of reinforcement shall ensure satisfactory performance of RC elements subject to plastic deformation under blast loading. The requirements are significantly different and more onerous than is necessary for conventional structures.
- (2) Main and Secondary Reinforcement shall be Hot-Rolled High-Yield deformed steel bars (HRHY) to BS4449 Grade 460.
- (3) Shear Reinforcement shall be Hot-Rolled Mild Steel bars (MS) to BS4449 Grade 250.
- (4) Cold worked high yield reinforcing bars shall not be used in explosives structures because of the high strain rates and large deformations expected.
- (5) Minimum reinforcement quantities for blast resistant structures shall be:
 - (a) 0.25% HRHY main bars each face.
 - (b) 0.2% HRHY secondary bars each face.
 - (c) 0.1% MS links for designed compression reinforcement.
 - (d) 0.04% MS links for nominal compression reinforcement.
- (6) Reinforcement shall be arranged so as to minimise laps where practical. Where laps in the main tension bars are necessary they shall be 72 diameters long to allow for the reduced bond strength in cracked concrete. Reinforcement shall have full development lengths at slab/wall and wall/wall junctions.
- (7) Regardless of the Section Type (as defined by UFC3-340-02) to be adopted, blast links shall be provided to enclose all layers of main and secondary steel in order to better contain the core concrete, improve dynamic response, increase shear capacity and limit the size of back face spall fragments. Links shall be “U” shaped, staggered (see annex A app 4) and at maximum spacing of 300mm. Links shall generally be used in preference to diagonal lacing bars for reasons of economy and practicality.
 - (a) Links shall be adequately bent around reinforcing bars at corners. Minimum hook length shall be the lesser of 20d each or two-thirds of the section thickness as shown in Annex A Appendix 4.
 - (b) Open links conforming with Shape Code 47 of BS 8666:2005 are acceptable provided that dimensions ‘C’ and ‘D’ are the lesser of 20d each or

two-thirds of the section thickness. The open end should face away from the PES (i.e. in the tension face).

(c) Closed links conforming with Shape Code 63 of BS 8666:2005 are acceptable provided that dimensions 'C' and 'D' are the lesser of 20d each or two-thirds of the section thickness.

(d) The use of Shape Code 51 to BS 8666:2005 is not permitted to be used as a blast link.

(8) Reinforcement shall generally utilise moderate sized bars (up to 25mm) at close centres in preference to large bars at large centres in order to better contain the core concrete, to improve dynamic response and to limit the size of back face spall fragments.

(9) Main and secondary reinforcement shall be provided equally in both faces of RC elements subject to blast loading in order to allow for reverse loading and rebound forces.

10.1.3 Additionally, in all structures, whether dynamically loaded or not, the crossovers of reinforcement in all RC elements are to be wire tied at every intersection, except where they are bonded (welded) in accordance with the requirements, in order to meet the electrical requirements to preclude side-flashing.

10.1.4 See Drawings in Annex A, Appendix 4 for typical UK reinforcement details and method of detailing to be adopted.

10.2 Structural Steel Components (including structural purlins)

10.2.1 Structural steel members required to provide resistance to blast loadings shall be able to develop their full plastic capacity during support rotation – i.e. only Plastic sections are to be used. Compact, Semi-Compact & Slender sections are not permitted.

10.2.2 Plastic deformations of structural purlins, within the permissible limits given in para 9.1, shall be used to produce an economic solution.

10.2.3 In order to avoid brittle modes of failure, member support connections shall be “over-strong”, and designed to withstand the maximum capable support reaction of the section under plastic rotation.

10.2.4 The Grade of steel used must remain ductile in the design environment and for the range of permissible deformations given. Grade 43C is generally acceptable in the UK.

10.2.5 Welded components, junctions or connections that are load-carrying and that are key to surviving an accidental explosion must:

(1) Be subjected to an agreed non-destructive test regime to demonstrate the competence of the welds.

(2) Be normalised after fabrication by an agreed heat-treatment process to relieve stresses in the heat-affected zones.

10.3 Brickwork

10.3.1 Brickwork to be used in the construction of explosives facilities is to have a minimum characteristic compressive strength of 27.5 N/mm² in 1:1:6 cement/lime/sand mortar. Bricks shall be solid and frost resistant (e.g. Engineering Class A or B). Where it is impractical to

obtain solid bricks, any hollows (e.g. frogs) shall be laid upwards and completely filled with mortar.

10.3.2 The use of concrete block-work as an alternative to brickwork is suitable only if solid blocks with a minimum compressive strength of 15.0 N/mm² are used. Concrete blocks do not necessarily meet Security requirements for break-in resistance and may require additional measures. Alternatively, hollow blocks with steel reinforced and concrete-filled voids may be considered. Where block walls are intended to act in pressure relief (e.g. HD1.3 storage), such strengthening measures are not acceptable.

10.4 Other Construction Materials

10.4.1 Flammable materials must not be used. Non-combustible materials should be used for the construction of facilities containing explosives. All construction is to be watertight and components moisture resistant. Furthermore:

- (1) Fixing of equipment to walls/roofs subject to high shock loads from an explosion shall be avoided where possible because of the potential debris hazard that could arise from dislodged equipment items.
- (2) Where equipment fixings to concrete walls subject to high shock motions are unavoidable, they shall utilise under-reamed anchors, or other suitable types that have been demonstrated to be able to perform adequately in cracked concrete. Parallel expanding anchors shall not be used in such locations.
- (3) Facilities for the storage of Compatibility Group (CG)'K' are to be provided with a non-absorbent finish on the floors and the walls to a height at least equal to the top of the explosives stacks.
- (4) Bulk Explosives Sensitive to Sparks or Friction:
 - (a) Facilities for the storage of bulk explosives sensitive to sparks or friction are not to have any exposed iron, steel, aluminium or aluminium alloy containing more than 1% of magnesium where it may come into contact with explosive substances.
 - (b) Where facilities are used for the storage of bulk explosives sensitive to sparks or friction, 'spark resistant' aggregates for the floor and walls are to be used.

10.5 Roofs

10.5.1 The roofs of PES are preferably to be either all heavy or all light, a heavy roof being one of at least 150 mm thick RC, or its equivalent. Light roofs (usually pitched roofs) are to be covered in a frangible material (e.g. glass reinforced polyester or light metal sheeting). Metal trusses are normally to be used, but on small buildings hardwood trusses are acceptable. Concrete roofs that are themselves not waterproof are permitted to have a suitable waterproof finish applied (e.g./ asphalt or mineral based felt). Propriety products may be equally suitable dependent on fire rating and approval. Arrangements are to be made on all roofs for rainwater discharge into open channels or gullies.

10.5.2 Whilst heavy roofs are preferable for all buildings, the decision on the type of roof to be provided will be dependent on the explosives to be stored and the existing local circumstances.

10.5.3 Roofs may be designed to have special functions such as:

- (1) Containment of fragments and prevention of lobbed items. The QDs for buildings that are designed to contain fragments and lobbed items are dependant on the design specification. In many cases, reduced QDs resulting from incorporating such roofs are permitted.
- (2) Shielding against blast, projections and lobbed items.
- (3) Walls may be designed to exclude firebrands, projections and lobbed items with a resulting reduction in QDs. However, this reduction often depends on the provision of a shielding roof.

10.6 Floors

10.6.1 Floor design loadings shall be adequate to support the stored explosives and handling equipment. Generally, the loading area will be of the order 10kN per standard pallet (approximately 1m² floor area). In some structures (e.g. igloos), stacks up to 5 pallets high may be utilised which can give rise to a concentrated loading of 50kN/m², however, gangways and access requirements will reduce the average floor loading. To make such floors dust free, they are to be treated with a proprietary sodium silicate solution or similar approved concrete sealer/hardener.

10.6.2 The floors of PES to be used for storage/processing of bulk explosives sensitive to spark or friction are to be surfaced with gritless asphalt or other approved substance (see para 10.4.1(4)). The use of linoleum is to be formally approved by DSA DOSR CIE(MOD).

10.6.3 Some facilities, particularly Process Buildings, may require to be fitted with Conductive or Anti-Static floors (see Chapter 8).

10.7 External and Internal Walls – Finish

10.7.1 PES designed as storehouses do not generally require any decoration internally or externally. In hot climates, external walls may be painted white to reflect heat. In Process Buildings, walls should have a smooth finish, free of cracks and crevices, painted with an oil-based or washable paint. Lead based paint must not be used. All corners should be rounded off to facilitate cleaning. Guidance regarding internal cladding and insulation may be obtained from DIO if required.

10.8 Drainage

10.8.1 Adequate drainage is to be provided for all PES. To avoid the ingress of water through door openings, the external slab should fall away from the building.

10.8.2 Drains exiting laboratories are to have a suitable and readily accessible trap fitted in order to intercept any explosives residues. Traps and drains are to be regularly cleaned to prevent any build-up of residue.

10.9 Doors

Door construction will vary according to the required degree of protection to stocks from fragments and whether a door traverse is present. Door materials shall comply with the requirements set out in Table 3. Locks shall comply with the requirements of JSP 440.

TABLE 3				
MINIMUM CONSTRUCTION REQUIREMENTS FOR ES DOORS				
ES Construction	PES Holdings			
	HD1.1 or HD1.2	HD1.3 or HD1.4	No PES present	Notes
Lightweight	As HD1.3/1.4 ⇒	Prime requirement is for Explosives Safety, but must also satisfy Physical Security	Prime requirement is for Physical Security	
Medium-walled (150mmR/C or 215mm brick)	16mm mild-steel plate	Generally to be an approved Class 3 Security door with, as a minimum: Solid 6mm mild-steel plate	Comply with Security requirements in JSP 440	
Earth-covered ESH	Security requirements to be incorporated into the design			
Heavy-walled (450mmR/c or 680mm brick)	50mm mild-steel plate	Or	Remote locations with longer response force times will require a higher Standard	
	Security requirements to be incorporated into the design	40mm hardwood faced with 1.6mm mild-steel		
Reduced QD locations	Special to Type	Locks, hinges etc to comply with Security requirements in JSP 440		Refer to TA(Structures)

10.9.1 Emergency escape doors for evacuation in fire, explosive or other emergency situation shall be located to satisfy:

- (1) Section 4 of Approved Document B1 of The Building Regulations 2000 (England & Wales), adopting **Purpose Group 2-7** in Table 3;
- (2) Technical Booklet E of the Building Regulations (Northern Ireland), **Adopting Places of Special Fire Risk** in Table 1.2;
- (3) Section 2 of the Technical Handbook, non-domestic, of the Scottish Building Standards (May 2005), adopting **Very Slow Evacuation** in Clause 2.9.3 (not Storage Building Class 1 or Place of Special Fire Risk).

10.9.2 In each country, a maximum escape distance of 9m where travel is possible in one direction only, and 18m for more than one permissible direction (see applicable Building Regulations for definitions of “permissible”). In process buildings (or any other occupied explosives facility), the maximum travel distance where travel is possible in more than one direction shall be reduced to 12m. In certain un-occupied storehouses where the provision of alternative means of escape is not possible (e.g. earth-covered storehouses and Igloos), approval may be given to increasing the maximum single-direction travel distance to 18m, but a request for a formal determination must be made in advance of construction to (or through, in the case of Scotland) DIO Building Control in accordance with MOD procedures.

10.9.3 Escape doors are not normally to be fitted with locks but are to have approved bolts on the inside and be provided with ‘Bales’ type catches that will operate by pressure on any part of the door. Panic bolts or latches that conform to BS EN 1125 may be provided instead of ‘Bales’ catches if security or other considerations warrant it. One escape door may also be used for access and can be fitted with an approved lock in place of the bolts, however, this lock must only be operable from the outside of the door.

10.9.4 Door openings are to be of dimensions commensurate with their required usage and are normally to open outwards. Sliding, folding and up-and-over types are permitted, however, these types of door are to be provided with, or have adjacent to them, an outwards opening personnel escape door.

10.9.5 An entrance step may be provided to protect stocks against ingress of dirt or water etc. The height of this step is not to exceed 75 mm and ramps must always be fitted.

10.10 Glazing

10.10.1 Glazing is the prime cause of injuries in explosive events. Consequently, the potential hazard from flying glass is of particular concern and must be addressed properly to satisfy duty-of-care requirements.

10.10.2 As it is a requirement to design all inhabited buildings inside IBD to resist blast pressures, fragments and debris (see para 9.1.2), it follows that glazing must also be designed such that, if exposed to a PES event, it must not give rise to a “HIGH hazard” (see ESTC Standard 5 for definitions). A summary of the glazing required at IQD is included in Table ‘2’. It shall be noted that at QD less than 14.8Q1/3, windows must not face PES, or must be effectively traversed.

10.10.3 Windows are not normally permitted in explosives buildings. However, where this is unavoidable practically (e.g. process buildings) they are to be as small as possible and (for security) shall be non-opening. In existing buildings, where opening windows have been provided, approved security grilles shall be fitted in accordance with JSP440. Windows shall be positioned where they will not admit direct sunlight; where this is not possible, and sunrays could fall upon explosives, the windows shall be covered or shaded.

10.10.4 To minimise the risk from fragments from a PES and from glass fragments at the ES, high level (or clerestory) glazing shall be used wherever possible. In occupied

explosives buildings, low level glazing must be designed to survive the blast-pressures at no more than "LOW hazard" in order to offer reasonable levels of protection to the occupants.

10.10.5 For framing requirements, see ESTC Standard 5 and Defence Estates Design & Maintenance Guide DMG02 "Glazing Standards for MOD Buildings Subject to Terrorist (i.e. read: explosive) Threat".

10.10.6 Glazing materials shall be chosen to reduce injuries to the occupants of inhabited buildings. The materials most suitable for use are:

- (1) Toughened Glass (full heat tempered). This glass is 4 to 5 times stronger than annealed glass and can therefore resist high blast loading if fitted in a strong rigid frame. The fragments produced when it breaks are small, cuboid and less injurious than those from annealed glass.
- (2) Laminated Glass. Laminated glass with a minimum thickness of 7.5 mm consisting of annealed glass with a 1.5 mm thick polyvinylbutyral (pvb) interlayer has a high blast resistance and does not produce such hazardous fragments as annealed or toughened glass. The resistance of the laminated glass to blast loading is provided largely by the pvb acting in catenary. To enable this resistance to be realised, deep rebates with polysulphide or silicon sealant should be used.
- (3) Polycarbonate. Polycarbonate with a minimum thickness of 6 mm, fitted into robust frames, is a tough flexible material with a high blast resistance. In comparison with other types of glazing, it is more expensive, less scratch resistant, degrades with time and exposure to solvents (e.g. cleaning materials) and can produce sharp fragments when it fails. As it is difficult for X-rays to detect such fragments in the human body, this should be addressed in the risk assessment before it is adopted for use. It is more useful as a secondary glazing material.

10.10.7 Untreated plain (Viz: annealed) glass or wired glass (Viz: Georgian-wired) must never be used at IQD. Between 22.2 and $14.8Q^{1/3}$, existing installations shall be upgraded to MOD Standard "NORMAL" (as defined in DE DMG02) using the appropriate application of anti-shatter film (ASF) and Bomb-Blast Net Curtains (BBNC) – alternatively the thicker film option may be adopted to dispense with the need for BBNC. Where plain or wired glass is used internally, the side remote from the PES shall be filmed. Where the primary blast can come from either side (from multiple PES), both sides shall be filmed. Inside $14.8Q^{1/3}$ only laminated or toughened glass solutions shall be used.

10.11 Hatches

10.11.1 Hatches may be provided in a Process Building between the working and transit areas if required.

10.12 Ventilation and Air Conditioning

10.12.1 PES should be kept as dry and temperate as possible. To assist in the reduction of condensation they should be provided with natural ventilation and, in some cases, dehumidification equipment.

10.12.2 To optimise the life of stored explosives it is desirable to limit the humidity and temperature in a storehouse or process building. The ideal conditions are:

- (1) The relative humidity should be maintained between 50 & 60%. Humidity levels higher than this may lead to deterioration of the explosives and lower levels may give rise to problems with static electricity for some types of stocks.
- (2) The temperature should generally be maintained between 5 and 25 degrees Celsius. Temperatures higher than this could cause damage to constituent ingredients. Further advice on temperatures for Process Buildings is provided in

Chapter 12, Chapter 17 and Chapter 19. The requirements of Chapters 17 & 19 override any general guidance given in this Chapter.

10.12.3 High and low-level ventilators are to be provided in all buildings and compartments that are not air conditioned. Exceptionally, in very small compartments, this requirement may be waived. However, where ventilators or air conditioning have not been provided, each compartment is to be carefully checked for dampness and deterioration of stocks during the periodic inspections of the PES. Ventilators may be either controllable from the exterior of the building, or of a permanent open type such as air-brick but, in any case, they are to comply with the security requirements of JSP 440. Where required, ventilators are to be fitted with suitable metal shields to prevent the ingress of rain or snow. Fire shutters with fusible links may be required for certain types of ventilator.

10.12.4 The buildings shall be well ventilated to limit deterioration of the stored explosives. Natural ventilation will normally be sufficient. To prevent penetration by fragments, air-bricks provided to cavity masonry walls shall be staggered horizontally, and those provided to solid masonry or reinforced concrete walls shall be protected by 6mm thick mild-steel cover-plates giving line-of-sight protection + 50mm in all directions.

10.12.5 If forced air ventilation is required and exhaust fans are necessary, these are to be fitted on the leeward side of the building. Suitable automatic louvres, fitted with small mesh metal grilles where necessary, are to be provided to ensure that there is no ingress of air when the fans are not running.

10.12.6 In hot climates, special arrangements are to be made to keep the contents of a PES as cool as possible by providing an interior ceiling or double roof and extending the width of the roof to protect the walls from the direct rays of the sun. In some PES, it may be necessary where the temperature range is critical, to provide insulating materials or air-conditioning. Alternatively, earth covered above ground or semi-underground buildings may be a suitable alternative. It may also be necessary to provide metal grille doors additional to the normal doors to enable the PES to be adequately ventilated during the night. The grille doors are to be fitted with approved locks.

10.12.7 Where it is necessary to provide air conditioning to meet specified restricted humidity conditions, the plant provided is to comply with the requirements of Chapter 8 of these regulations and be type approved by DIO for use in a PES.

10.12.8 In cold climates, it may be necessary for ventilators to be designed to prevent the ingress of snow either by closing them or the fitting of temporary blanks during the inclement weather.

10.13 Dust Extraction Systems

10.13.1 In certain Process Buildings where explosives are exposed, it may be necessary to install an explosives dust extraction system. DIO are to be consulted, through the appropriate IE, regarding designs, which may incorporate flame arrestors or barriers to propagation, prior to inclusion in the building.

10.14 Heating

10.14.1 Heating may be provided by means of steam, hot water, or by electric heating to the requirements of Chapter 8. Suitable guards are to be provided to prevent explosives, stores containing explosives, or their packages from encountering any heated surface, pipes or radiators. The guards are to be designed such that items cannot be placed on them (e.g. they are to have sloping tops).

10.15 Lighting and Other Electrical Installations

10.15.1 Lighting and other electrical installations are to be suitable for the Category of the PES and comply with the requirements.

10.16 Building Services

10.16.1 Services to Process Buildings, such as compressed air or vacuum facilities and associated plant, water supplies/drainage for washing/toilet purposes, etc, may be provided in Process Buildings to local requirements. All pipelines or conduits carrying services are to be colour coded to show the nature of their contents and bonded at the entry and exit to/from the building or compartment. This colour coding is to be at the building entrance and at such other points as are necessary to avoid confusion. The colour code to be used is that shown in BS 1710.

10.17 Lightning Protection System (LPS)

10.17.1 Generally, an LPS is required for all PES.

10.18 Bonding of Metal

10.18.1 All metal used in the construction of a PES, including the reinforcement in RC structures, is to be effectively bonded to the lightning protection system.

10.19 Precautions against Static Electricity

10.19.1 Adequate precautions must be taken to prevent the accumulation of static electrical charges. Normal precautions against static electricity are provided by earthing and bonding all anti-static and conducting materials and all plant and equipment.

10.20 Earthing Requirements

10.20.1 When a specific earthing requirement is stipulated by an equipment PT, PES is to be fitted with a continuous copper earthing strip around the internal walls at a height of 1 m. This earthing strip is to be bonded to the lightning protection system

10.21 Conducting and Anti-Static Floors or Mats

10.21.1 The floors of any Process Building in which maintenance procedures are carried out on explosive stores requiring maximum anti-static precautions, or on an Electro-Explosive Device (EED) or store containing an EED, are to be of the conducting or anti-static type.

10.22 Lifting Appliances

10.22.1 PES intended to contain heavy or bulk stores are either to be provided with an approved overhead hand operated or electric crane, or the construction of the PES is such that it will allow for the use of mobile handling, lifting and stacking equipment. Where lifting appliances are installed they shall comply with, in addition to any explosives safety considerations, the current edition of the Lifting Operations and Lifting Equipment Regulations (LOLER).

10.23 Security

10.23.1 In addition to the requirements of this chapter, the storage of ACTO explosives is to comply with the requirements of JSP 440.

10.24 Fire Protection Measures

10.24.1 Information on fire protection measures can be found in Chapter 15. Fire protection measures for each explosives facility shall be agreed with the Fire Focal Point (FFP). For new facilities, the requirements shall be drawn up and agreed with the FFP as part of the Statement of Requirement (SOR) during Stage 1 of the procurement process.

11 BLAST DESIGN METHODS AND VALIDATION

11.1 Blast Design

11.1.1 The design of elements subject to blast and shock loadings shall be carried out by competent persons (i.e. as a minimum: Chartered Civil or Structural Engineers) with suitable and sufficient experience in blast design. TA (Structures) maintains a register of commercial consultants deemed suitable on behalf of DSA DOSR CIE(MOD). Additional consultants may apply through DSA DOSR CIE MOD for inclusion on the register subject to interview and assessment by DSA DOSR CIE MOD and TA (Structures).

11.1.2 The design of the structural elements shall address all considerations relevant to the explosives effects including:

- (1) Primary fragments.
- (2) Secondary high-velocity debris.
- (3) Debris or other missile impact.
- (4) Blast pressure, duration and impulse.
- (5) Blast reflected pressure enhancement internally.
- (6) Blast attenuation and blast leakage outside the facility.
- (7) Fragment penetration and perforation.
- (8) Dynamic response, flexure, shear and rebound.
- (9) Back face spalling.
- (10) Breaching.

11.1.3 Construction thicknesses must be validated. Any minimum requirements indicated in Regulations shall also be met.

11.1.4 Certain survivability features in terms of layout and detail have evolved through many years of design and testing and are specified in this Chapter; these shall be incorporated into the designs as minimum requirements.

11.1.5 The principle design reference shall be the current edition of the "Structures to Resist the Effects of Accidental Explosions" Manual TM5-1300. Other appropriate and standard references and texts may be used as required, including related PC programmes. It should be noted that there are several discrepancies between and within the various design texts, and the designer shall satisfy himself as to the correctness and appropriateness of the methods used. The suitability of the chosen method shall be demonstrated to the satisfaction of the DSA DOSR CIE MOD Compliance Office and TA (Structures). The ruling of the DSA DOSR CIE (MOD) Compliance Office and TA (structures) on the applicability or interpretation of standard references and texts shall be final and binding.

11.1.6 The design shall be based on the specified explosives quantities authorised by the IE, and the limiting damage/injury levels in this Chapter (or as otherwise provided by the IE). The 20% additional factor of safety for charge weight recommended in paragraph 1-7 of Chapter 1 of TM51300 shall be adopted for all MOD designs unless otherwise agreed with TA (Structures) in writing.

11.1.7 The design shall consider the most onerous combination of normal static loads (using realistic assessments of dead and live combinations) and, the dynamic loads associated with the explosives quantities and any potential impact loads from other sources (e.g. ejector seats). The design must demonstrate resistance both to localised effects on individual structural members and overall effects on the global structural system.

11.1.8 Approximate Single Degree of Freedom (SDOF) methods advocated in the design references may be used where appropriate.

11.2 Blast Design Calculations

11.2.1 All calculations and drawings shall be made available to TA (Structures) for examination. A suitable and agreed period shall be allowed for in the works programme for each submission (also to apply to re-submissions of any rejected work).

11.2.2 The following shall also apply:

(1) A statement outlining the design philosophy shall be submitted to TA (Structures) for comment before proceeding with detailed calculations. A copy of the agreed philosophy shall be placed at the head of the detailed calculations.

(2) Final detailed calculations for principal elements, damage/injury levels and any special considerations (Project specific) are required to be accepted by the IE and TA (structures) prior to commencing construction.

(3) Calculations shall be presented in a clear, legible and concise form, fully indexed, referenced and annotated. All input shall be referenced to ensure easy verification and all output summarised. All sources of information, standards, manuals and equations used shall be clearly identified and, where appropriate, supporting documentation appended. Photocopies of all charts used (or print-outs from authorised computer-generated versions) shall be provided showing the derivation of the values used. Locally developed spreadsheet applications may not be accepted due to the impracticality of checking them.

(4) Recognised and un-modified computer programmes may be used, but input & output screens shall be included in the calculations. Non-recognised or modified programmes must include Quality Assurance compliance information, together with details of verification procedures/methods that have been carried out to establish their accuracy and reliability for blast related work. No assurance is given that such programmes will be accepted.

(5) Where computer design methods are employed, an appropriate comparative hand calculation shall be carried out to demonstrate the reliability of each programme used.

(6) All calculations shall be fully checked and reviewed prior to submission by competent persons.

11.3 Designs and their Retention

11.3.1 Technical Adviser (Structures) to DOSR can provide advice on all matters concerning construction of explosives facilities. Additionally, they have a comprehensive library of approved designs for explosives facilities. IE staff are to provide copies of any 'as built' drawings to TA (Structures) to expand this library and maintain a record of actual construction for future reference.

11.3.2 Specific queries relating to construction matters should be addressed to the DOSR Technical Adviser (Structures). Further information and basic structure designs can be found in Annex A.

11.4 Approval of Designs

11.4.1 Only designs formally approved by TA (Structures) and TA (Electrical) are to be used in the construction of PES. This formal approval is to be obtained by the IE through DSA DOSR CIE MOD Compliance Office prior to the commencement of construction. The relevant IE is to be consulted by units at all stages of a project to ensure that any perceived difficulties, or planned changes to these regulations, are addressed at an early stage in proceedings. This requirement also applies to any substantial structural modification to an existing facility.

CHAPTER 6**ANNEX A****STANDARD BUILDINGS FOR MILITARY EXPLOSIVES****CONTENTS**

Paragraph

1 STANDARD IGLOOS

- 1.1 Performance Criteria as Exposed Site
- 1.2 Design Loads for Igloos as Exposed Site
- 1.3 Igloo Doors
- 1.4 UK Single Bay Box Igloo
- 1.5 UK Double Bay Box Igloo
- 1.6 Single Bay Modified Igloo (Freeloc)

2 OTHER STANDARD STOREHOUSES

- 2.1 Steel Arch Igloo
- 2.2 Unit Explosives Storehouse
- 2.3 25 kg Storehouse
- 2.4 Steel Frame Medium Wall Storehouse
- 2.5 Storehouse for Explosives of HD 1.3

3 TYPICAL PROCESS BUILDINGS

- 3.1 General
- 3.2 General Purpose Ammunition Process Building
- 3.3 Ammunition Test Building
- 3.4 Guided Weapon Workshop and Store
- 3.5 Reinforced Concrete Box Structure with Frangible Roof
- 3.6 Integrated Weapons Complex
- 3.7 Weapon Process Building (WPB)
- 3.8 Multi-Purpose Process/Storage PES
- 3.9 Explosives Preparation Room
- 3.10 Belt Filling & Paint Tipping Building
- 3.11 Major Proof Centre
- 3.12 Ejection Seat Store
- 3.13 EOD Complex

Appendixes

- 1 Typical Storage Buildings
- 2 Typical Process Buildings
- 3 Blow-Out Panels
- 4 Reinforcement and Blast Link Details

1 STANDARD IGLOOS**1.1 Performance Criteria as Exposed Site**

1.1.1 Standard Igloos are fully pre-designed structures that require only the design of foundations and other elements, which depend on individual site conditions. They have been designed to a 90% level of confidence that, as an ES, collapse or door failure will not occur when exposed to the blast loading from an explosion at a nearby PES at the appropriate IMD. Drawings of these buildings may be obtained from TA(Structures) at:

DIO
 Specialist Services (Protected Buildings & Weapon Effects)
 St George's House
 Blakemore Drive
 Sutton Coldfield
 West Midlands, B75 7RL

1.1.2 Any deviations from the Standard Drawings, however small, must be agreed in writing with TA(Structures). Significant changes may require complete re-validation of the structure and are to be avoided.

1.1.3 Deflections have been limited to maintain structural integrity and so that they will not be larger than the width of the air gap around the explosives within such that the structure will not strike the explosives. The support rotations of all the RC elements and the doors shall be limited to 4° and 12° respectively.

1.1.4 Major spalling of the RC elements of a structure should be prevented to avoid initiation of explosives within. To avoid major spalling, the spall velocities shall be limited to:

- (1) Spall Velocities >50 ms – KE no greater than 2500 J.
- (2) Spall Velocities <50 ms – Momentum no greater than 100 Ns.

1.1.5 Standard igloo construction should prevent major spalling of RC members occurring, however, the limits above may not prevent initiation of sensitive primary explosives.

1.2 Design Loads for Igloos as Exposed Site

1.2.1 The blast parameters that standard igloos have been designed to resist are as follows:

- (1) 3 Bar Igloo. When igloos are constructed with their axes parallel, account must be taken of the explosion effects from another igloo in a side by side situation. The separation distance (IMD) D3 is given by $0.5Q^{1/3}$. The blast parameters for the dynamic design of the igloo structure are as follows:

Element	Peak Positive Overpressure (kPa)	Positive Impulse (kPa-ms)	Positive Duration (ms)
Head Wall, Doors, Rear and Side Walls	300	$100 Q^{1/3}$	$1.0 Q^{1/3}$
Roof	600	$100 Q^{1/3}$	$1.0 Q^{1/3}$

- (2) 7 Bar Igloo. When igloos have the same longitudinal axis and the head wall and doors of one are exposed face-on to the rear wall of another (or vice-versa), the separation distance (IMD) D4, front to back, is given by $0.8Q^{1/3}$. Igloos should not be sited with their doors facing each other. The blast parameters for the dynamic design of this igloo structure are as follows:

Element	Peak Positive Overpressure (kPa)	Positive Impulse (kPa-ms)	Positive Duration (ms)
Head Wall, Doors, (and Rear Wall if the position is reversed)	700	$200 Q^{1/3}$	$1.0Q^{1/3}$
Side Walls	300	$100 Q^{1/3}$	$1.0Q^{1/3}$
Roof	600	$100 Q^{1/3}$	$1.0Q^{1/3}$

1.3 Igloo Doors

1.3.1 In addition to the positive phase blast effects, the igloo doors should be designed to resist the loads that may occur during the negative phase of the blast loading. An equivalent static pressure of 0.5 bar over the surface area of the doors should be taken for support restraint design. The doors are not required to remain in position under full rebound loads.

1.3.2 Fragment attack on the door and head wall is not of particular significance provided that end-on conditions apply. Typical fragments have <1 kg mass and velocity up to 300 m/s. A MS door with plate thickness of 20 mm will resist the perforation of all fragments within these limits. A 16mm plate thickness will reduce the residual velocity such that sympathetic detonation should not occur.

1.4 UK Single Bay Box Igloo

1.4.1 This is an RC portal type structure with a minimum of 600 mm of earth cover on the roof and earth cover against the side and rear walls. The slope of the earth against the walls is dependent on the material type used but should have a maximum slope of 1:2 (approximately 26°).

1.4.2 Access into the igloo is through a top-hung sliding steel door and a steel personnel door, both located in the headwall. The foundations are RC strip footings with a separate ground-bearing floor slab. The internal dimensions are 16 m long, 9.12 m wide and a minimum of 4.6 m high. The structure has been dynamically designed to resist the blast effects as an ES from an explosion in a nearby PES.

1.4.3 This igloo has been designed at the relevant QDs as a PES and an ES for a nominal maximum NEQ stored of 75 000 kg of HD 1.1 and up to 250 000 kg of HD 1.2 or HD 1.3. Greater NEQs may be stored, but a design check must be carried out to determine any structural alterations required. This igloo is illustrated at Appendix 1, Fig 1 and Fig 2.

1.5 UK Double Bay Box Igloo

1.5.1 This is an RC structure as described in the above paragraphs, except that the roof slab is supported at midpoint by a longitudinal RC beam spanning on to RC columns at ~4 m centres. The internal dimensions are 16 m long, 18.64 m wide and a minimum of 4.6 m high. NEQ limits are as for a single bay igloo. This igloo is illustrated at Appendix 1, Fig 3 and Fig 4.

1.6 Single Bay Modified Igloo (Freeloc)

1.6.1 This is an RC portal type structure with an arched roof and integral base slab and a minimum of 600 mm of earth cover on the roof and earth with a maximum slope of 1:2 on the rear and sides. The internal dimension is 24.38 m long, 7.62 m wide with a maximum height of 4.27 m. Access is through a top-hung sliding steel door or doors.

1.6.2 Ventilators are provided in the front and rear walls so that natural ventilation occurs. NEQs are as for a single bay igloo. This igloo is illustrated at Appendix 1, Fig 5 and Fig 6.

2 OTHER STANDARD STOREHOUSES

2.1 Steel Arch Igloo

2.1.1 This igloo is formed of corrugated steel sheeting with RC front and rear walls and base slab with earth cover and NEQs as for other forms of igloo. This structure is not generally designed to resist blast loading and must be sited at an appropriate IMD.

2.1.2 The internal dimensions are 17.98 m long, 7.62 m wide and a maximum height of 4.37 m. Access is through two heavy-duty side-hung steel doors. The general arrangement of the structure and member sizes is at Appendix 1, Fig 7 and Fig 8.

2.2 Unit Explosives Storehouse

2.2.1 A Unit Explosives Store is a single storey, compartmentalised, flat roofed building. The roof and floor slab are RC, supported on the external cavity and solid masonry cross-walls. Access into each compartment is through double doors in the front elevation. For security reasons, the inner wall is to be constructed of bricks not blocks, unless approval in writing is given by the appropriate Security Authority. This building is illustrated at Appendix 1, Fig 9.

2.3 25 kg Storehouse

2.3.1 This is a small RC box structure with overall dimensions of 5x3x2.85m. It has been designed to hold a maximum NEQ of 25 kg of HD 1.1 at reduced OQDs and is illustrated at Appendix 1, Fig 10.

2.4 Steel Framed Medium Wall Storehouse

2.4.1 This is a single-storey steel framed building with mono-pitched RC roof and masonry cavity perimeter walls. This structure is not generally designed to resist blast loading and must be sited at an appropriate IMD. Access is through doors located in the side elevation. This building is illustrated at Appendix 1, Fig 11 and Fig 12.

2.5 Storehouse for Explosives of HD 1.3

2.5.1 This is an RC single storey box structure with a part frangible front wall. Overall dimensions are 37 x 16.22 x ~6.2m.

2.5.2 This structure is not generally designed to resist blast loading and must be sited at an appropriate IMD. Access to the building is through two top-hung sliding steel doors located in the front elevation. This building is illustrated at Appendix 1, Fig 13 and Fig 14.

3 TYPICAL PROCESS BUILDINGS

3.1 General

3.1.1 It is beyond the scope of this Annex to provide detailed guidance on the many types of Process Building (PB) that could be required for explosives manufacture maintenance and testing. Design fundamentals to be adopted are given in the main Chapter.

3.1.2 Older Process Buildings were not generally designed to resist blast loading. Protection against high velocity missiles was provided by traverses, heavy walls acting as traverses, together with a protective roof. These buildings are not generally satisfactory as the weight of debris from the structure at collapse would cause serious injury to the occupants.

3.1.3 The typical PB arrangements following are indicative of real facilities, but which have not necessarily been pre-designed.

3.2 General Purpose Ammunition Process Building (APB)

3.2.1 This structure is used for the assembly and maintenance of explosives. The arrangement of the plant room, shifting lobby, office, etc, may be altered to suit the specific requirements of the individual building. The construction consists of an RC frame and slabs with clerestory glazing and masonry cavity external walls. The general arrangement and member sizes are illustrated at Appendix 2, Fig 1 and Fig 2.

3.2.2 APBs are designed to promote flexibility in use. However, this principle does not debar the construction of a Process Building to meet a specific requirement (e.g. for the surveillance of large missiles or the sampling of bulk explosives). APBs are always to be

provided with a traverse(s). As an ES, or where personnel who are not directly involved in the processing activity are exposed to risk of injury, the design must give them reasonable and practicable protection.

3.3 Ammunition Test Building

3.3.1 This is a single storey RC building used for the testing of ammunition. It has 600 mm thick walls and roof, with a light-weight frangible GRP front wall. It has been designed to resist an internal explosion without collapse or extensive damage occurring. The overall dimensions (lwh) are 7.25 x 6.85 x 4.1 m. A maximum NEQ of 100 kg of HD 1.1 may be present in this building. The general arrangement and member sizes are illustrated at Appendix 2, Fig 3 and Fig 4.

3.4 Guided Weapon Workshop and Store

3.4.1 This is a single storey RC framed building with a flat RC roof slab, cavity masonry panel walls and overall dimensions of 19.05 x 9.7 x 3.7 m. The general arrangement and member sizes are illustrated at Appendix 2, Fig 5 and Fig 6.

3.5 Reinforced Concrete Box Structure with Frangible Roof

3.5.1 This is a single storey earth mounded RC structure with a pitched frangible roof. Internal dimensions are 10 x 10 x 4 m clear height. The general arrangement is illustrated at Appendix 2, Fig 7.

3.6 Integrated Weapons Complex

3.6.1 This facility was designed to be used for the assembly, maintenance and alongside testing (see Chapter 19) of missiles and torpedoes. The layout consists of four Weapon Assembly and Check Rooms (WACR) positioned in a cruciform shape around a central Test Equipment House (TEH) and two independent plantrooms.

3.6.2 The construction is determined by the blast parameters from a given amount of explosives in a WACR and is designed to give reasonable levels of protection to workers in an adjacent WACR and higher levels of protection to personnel in the TEH. The design has been verified by trials.

3.6.3 The TEH is of reinforced concrete box construction and is separated from the WACR construction to reduce shock transfer. Heavy blast doors are provided (mechanically actuated and interlocked) and there are no windows. This design affords protection both to the occupants and test equipment.

3.6.4 Each WACR has three thick reinforced concrete walls which serve as container traverses. Internal dimensions are approximately 24.5m long x 10.5m wide x 6.6m high. The roof and front wall are designed to be lightweight frangible vents with the front wall additionally provided with a vertical RC traverse. Efflux vent holes are provided in two side walls. A personnel escape door is provided at the rear of each WACR with an external door traverse. See Appendix 2, Fig 8 to Fig 10.

3.7 Weapon Process Building (WPB)

This is a building (other than an IWC) dedicated to the processing of sophisticated weapons. As an ES, or where personnel who are not directly involved in the processing activity are exposed to risk of injury, the design must give them reasonable and practicable protection.

3.8 Multi-Purpose Process/Storage PES

3.8.1 A multi-purpose process/storage PES, such as a Unit Ammunition Store, may be constructed in the same way as any of the building types described in this chapter. Where personnel who are not directly involved in the processing activity are exposed to risk of

injury, the design must give them reasonable and practicable protection. Where practical, the design should limit or prevent propagation between the attached rooms.

3.9 Explosives Preparation Room

3.9.1 Where personnel who are not directly involved in the processing activity are exposed to risk of injury, the design must give them reasonable and practicable protection.

3.9.2 An explosives preparation room has the following constructional requirements:

- (1) The walls of the facility are to be 215mm nominal solid brickwork brick or an equivalent alternative.
- (2) If it is in a compartmented building, then access to the room is to be from the outside only.
- (3) Blast walls are to be provided at the entrance and at any window facing an adjacent building or area where personnel are placed at risk.
- (4) To reduce the risk of propagation, storage cupboards within the building or compartment are to be provided and are to be used to separate the explosive stores into small quantities. The cupboards are to be constructed of not less than 102 nominal solid brickwork and are to be fitted with securely fastening steel or hardwood doors.
- (5) The requirements of Chapter 19 are to be complied with.
- (6) The quantities stored are limited to the minimum compatible with requirements and are not to exceed the NEQ stipulated.

3.10 Belt Filling and Paint Tipping Building

3.10.1 A building used for the preparation of belts of aircraft ammunition, including the tipping of heads with paint, is to be constructed of 215mm nominal solid brickwork or equivalent and have a 150 mm RC roof. Where tipping paints are used, an appropriate ventilation system is to be installed. Where the ammunition is electrically initiated, conductive precautions are to be taken.

3.11 Major Proof Centre (MPC)

3.11.1 MPCs were established on a regional basis to carry out proof and chemical testing under laboratory conditions in the principal ammunition depots. An MPC is purpose built to a standard design at least comparable in specification to that of an APB. It comprises several small test rooms, proof facilities and test rigs. The electrical standards are, however, higher than those found in a general APB due to the nature of activities undertaken. With the advent of In-Service Proof of the complete round, the requirement for component proof and chemical testing has lessened considerably, although the capability is maintained for specific tasks.

3.11.2 As an ES, or where personnel who are not directly involved in the processing activity are exposed to risk of injury, the design must give them reasonable and practicable protection.

3.12 Ejection Seat Store

3.12.1 An ejection seat store shall be substantially constructed, having a 200mm RC roof, with the external walls (including the preparation area) of 300mm RC. It is to be divided into internal compartments with 200mm RC walls. The design must prevent perforation of any wall as a consequence of a combination of kinetic energy from the impact from an

accidental firing of an ejection seat either within a storage compartment or the preparation area.

3.12.2 Each compartment is to have an inward opening 6 mm thick mild steel door attached by a minimum of three hinges, welded to the door and the door frame. The door is to be closed using a minimum of two dog catches and one hasp and staple. Door frames shall be robustly anchored into the RC walls with cast-in tangs (or equal ties) designed to withstand the forces involved. The rear elevation of each storage compartment (i.e. opposite the door) shall be a full-size vent, incorporating a lightweight frangible panel of box-section GRP. For security, an approved security mesh shall be fitted inside the panel. Where the required QD to the vent panels cannot be achieved, a reduced QD may be achievable by strengthening the security grille such that it can contain the rocket packs and/or ejection seat within the compartment.

3.13 EOD Complex

3.13.1 An EOD complex is a specifically designed building constructed of reinforced concrete. Controlled explosion venting is supplied by frangible panels in the roof. The main garage doors are blast resistant. A blast wall is erected along the outside of the doors to provide mitigation for any event that might occur when the doors are open. The effective NEQ for each bay within the complex is limited to 10 kg, with the overall NEQ of the building normally limited to no more than 200 kg. This ensures that the external IBD generated by blast escaping through the roof or door is limited to 15 metres.

Intentional Blank Page

CHAPTER 6**ANNEX A****APPENDIX 1****TYPICAL STORAGE BUILDINGS****CONTENTS**

Fig		Page
1	Standard Storehouse - UK Box Igloo (Single Bay)	40
2	Standard Storehouse - UK Box Igloo (Single Bay)	41
3	Standard Storehouse - UK Box Igloo (Double Bay)	42
4	Standard Storehouse - UK Box Igloo (Double Bay)	43
5	Standard Storehouse - Freloc Igloo (Modified)	44
6	Standard Storehouse - Freloc Igloo (Modified)	45
7	Typical Storehouse - Steel Arch Earth Mounded Igloo	46
8	Typical Storehouse - Steel Arch Earth Mounded Igloo	47
9	Standard Storehouse - Unit Ammunition Store	48
10	Standard Storehouse - 'TO' Type Explosives Store	49
11	Typical Storehouse - Steel Framed Medium Walled ESH	50
12	Typical Storehouse - Steel Framed Medium Walled ESH	51
13	Typical Storehouse - ESH for HD 1.3 Explosives	52
14	Typical Storehouse - ESH for HD 1.3 Explosives	53

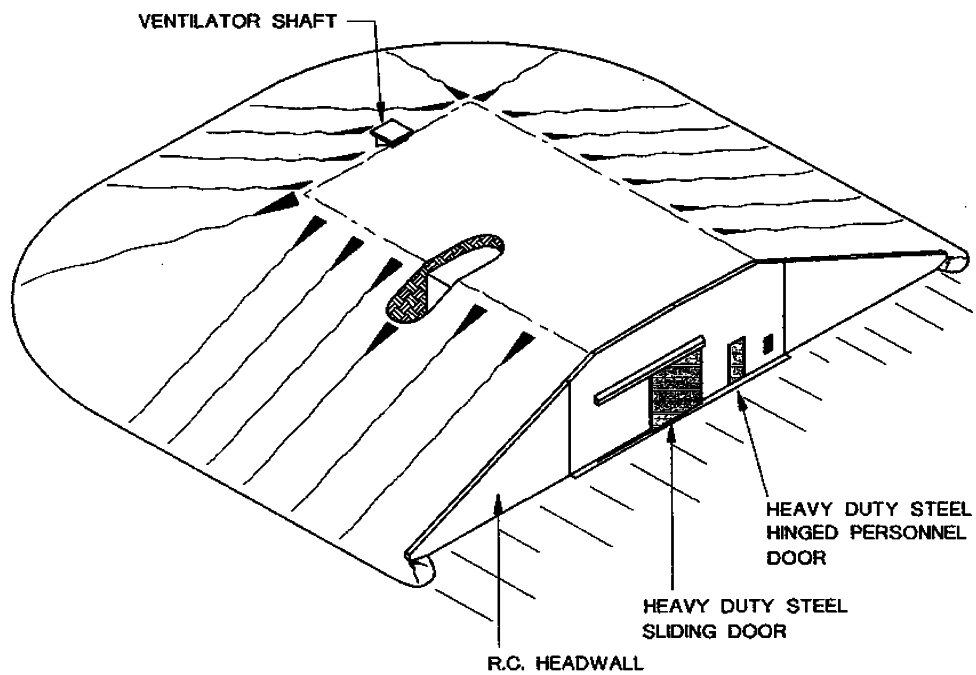
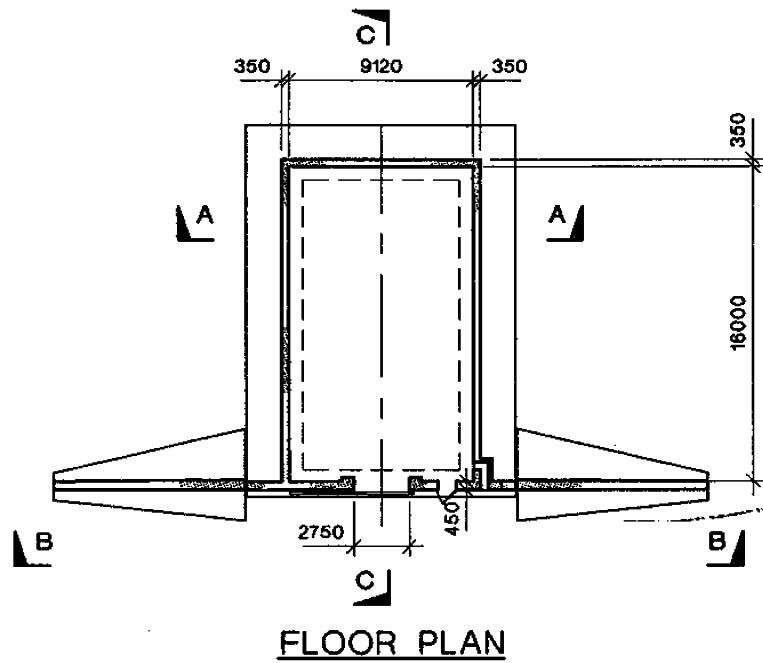

STORAGE CAPACITY: 4 x 10 x 3 HIGH = 120 STANDARD NATO PALLETS

EXPLOSIVE LIMIT: 75,000 kg, TNT EQUIVALENT

INTERNAL DIMENSIONS = 9120x16000x4600 = 6.0 m³ VOLUME

Fig 1 Standard Storehouse - UK Box Igloo Single Bay)

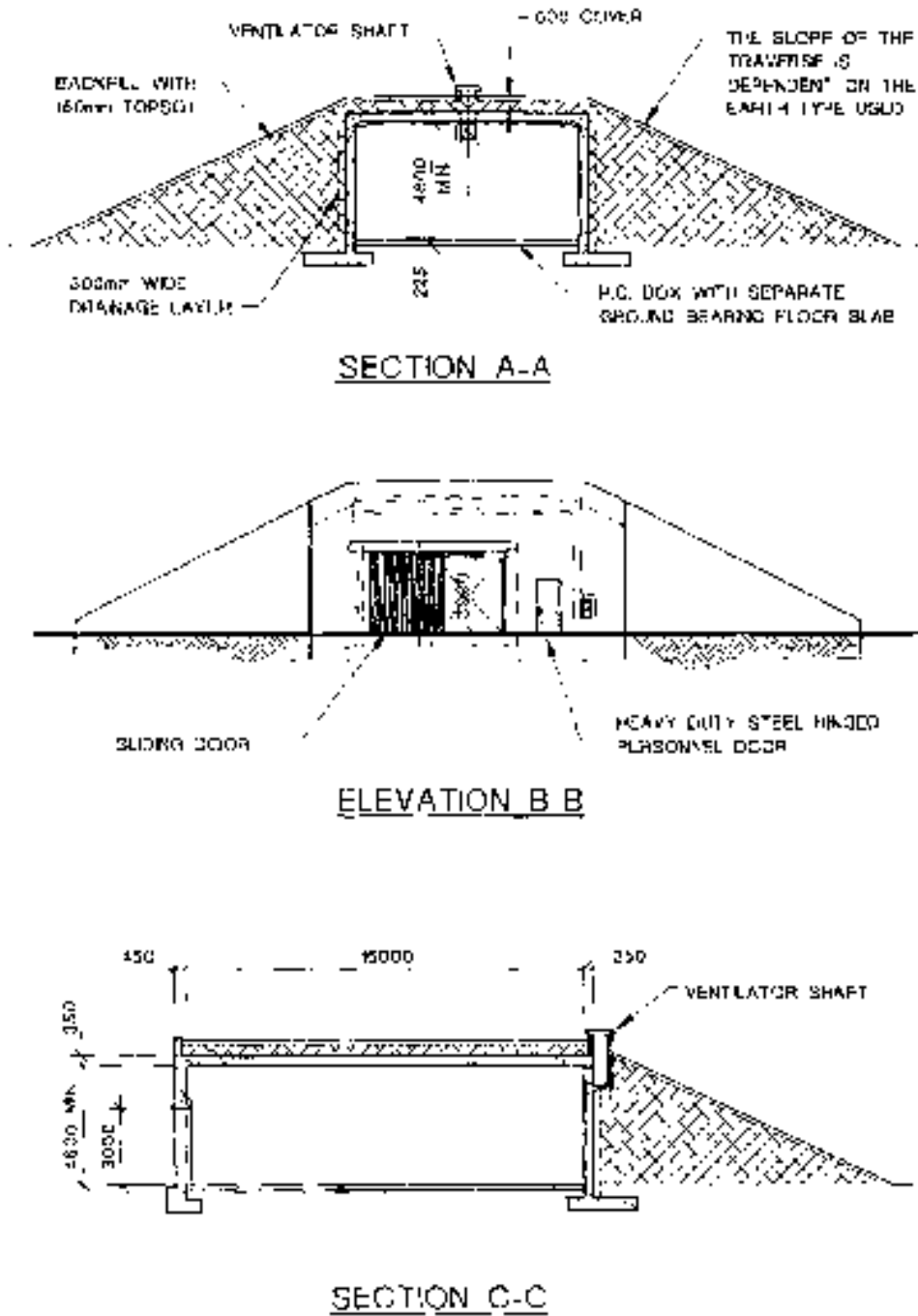
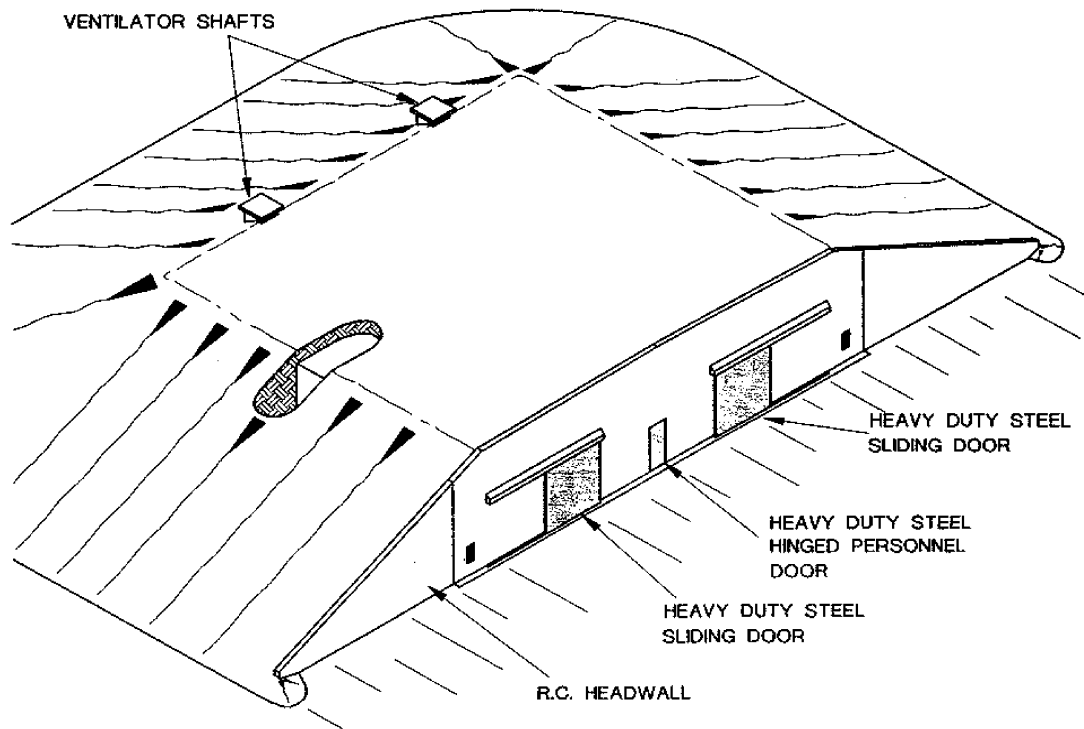
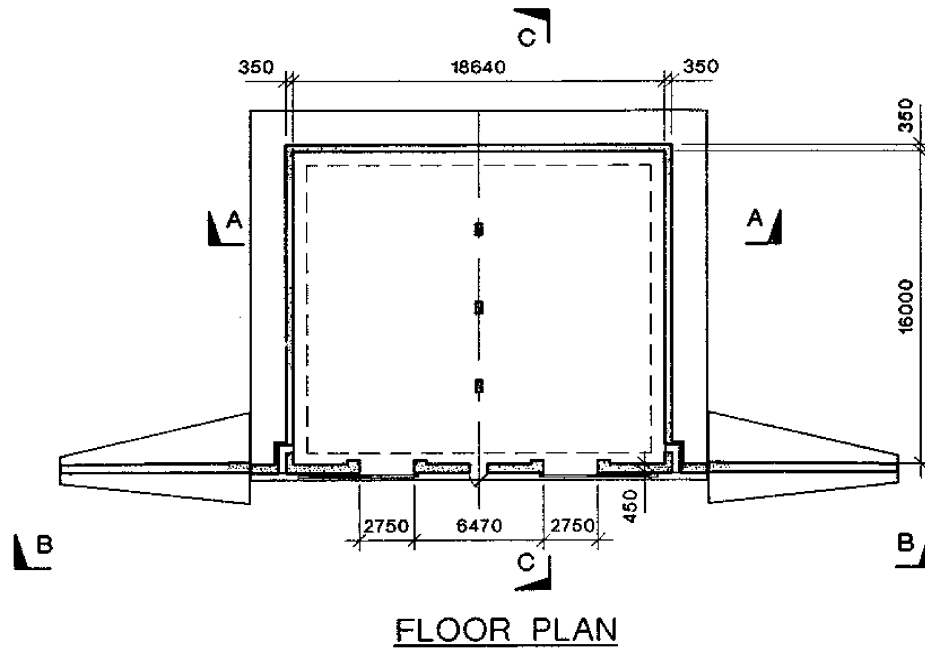

Fig 2 Standard Storehouse - UK Box Igloo (Single Bay)



STORAGE CAPACITY: $2 \times (4 \times 10 \times 3) = 240$ STANDARD NATO PALLETS
 EXPLOSIVE LIMIT: 75,000 kg. TNT EQUIVALENT
 INTERNAL DIMENSIONS = $18640 \times 16000 \times 4600 = 1372 \text{ m}^3$ VOLUME

Fig 3 Standard Storehouse - UK Box Igloo (Double Bay)

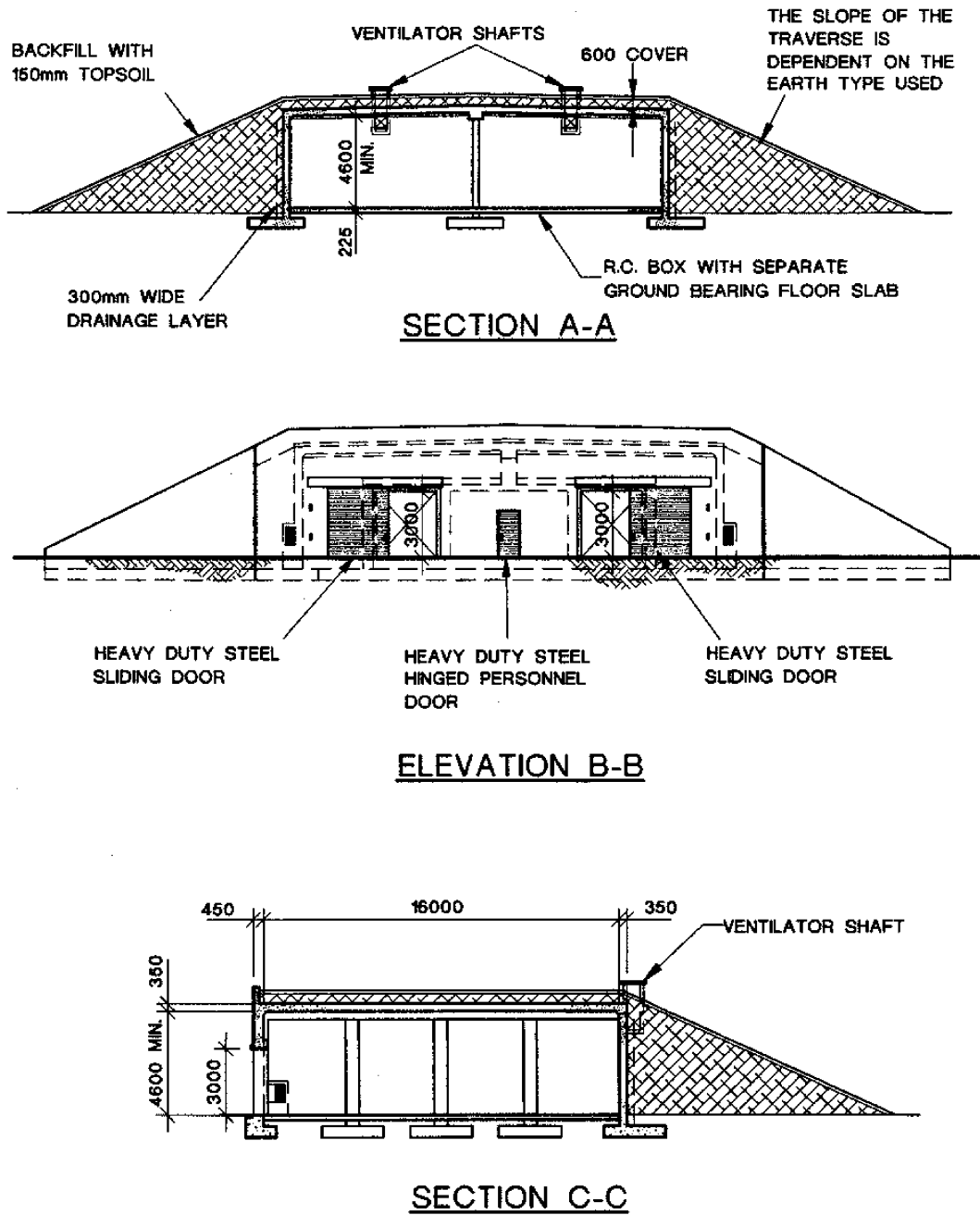

Fig 4 Standard Storehouse - UK Box Igloo (Double Bay)

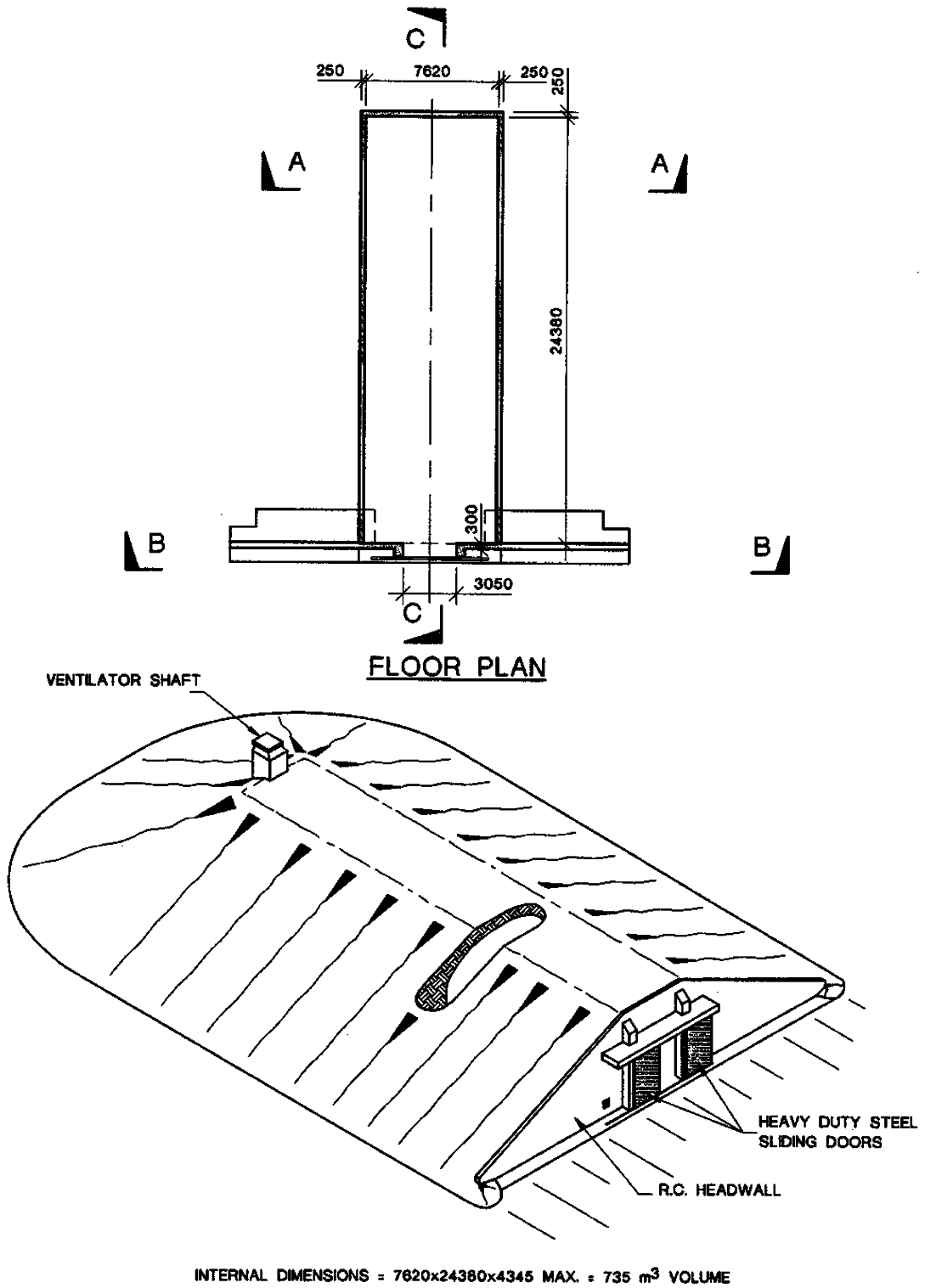

Fig 5 Standard Storehouse - Freloc Igloo (Modified)

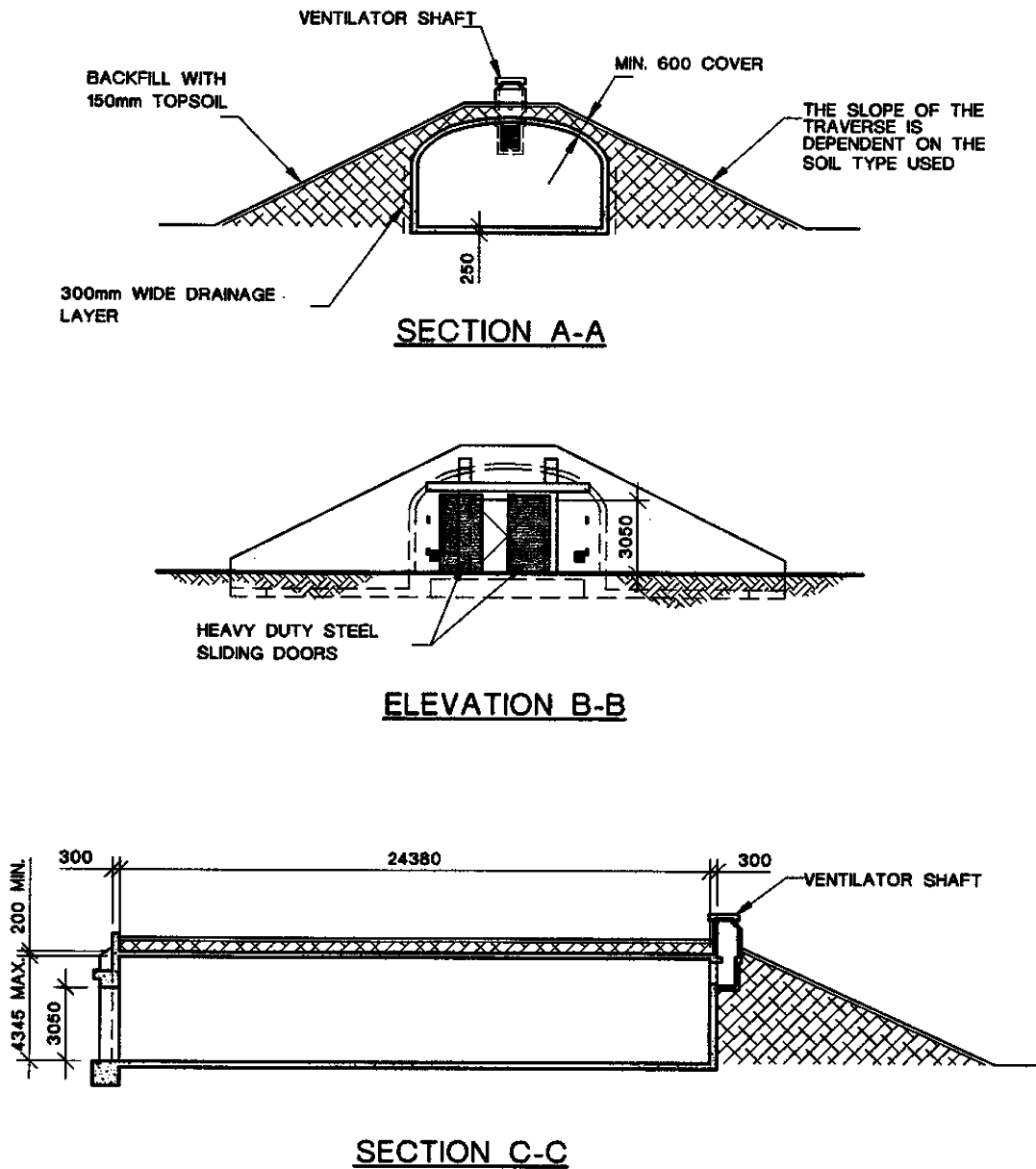

Fig 6 Standard Storehouse - Freloc Igloo (Modified)

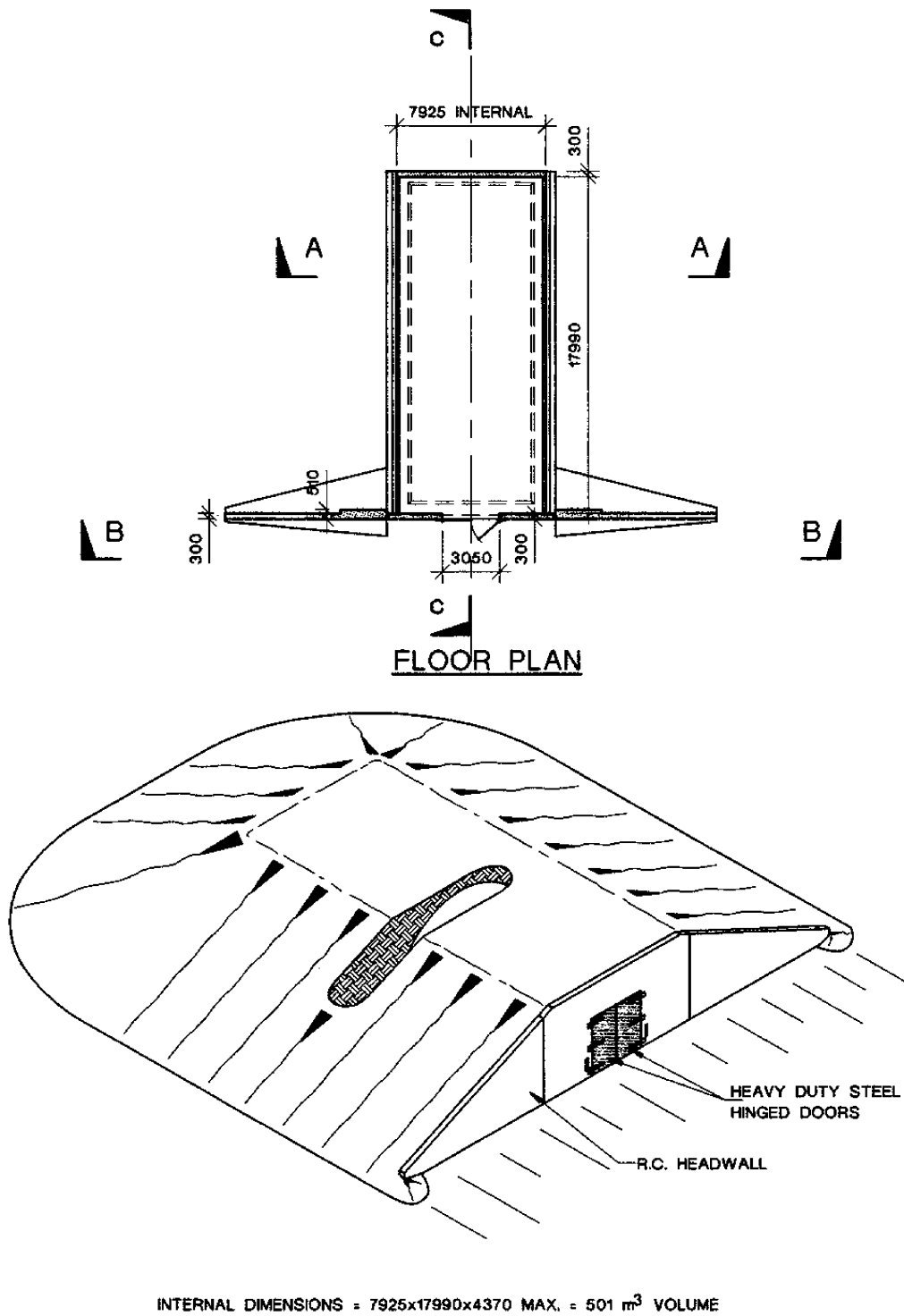

Fig 7 Typical Storehouse - Steel Arch Earth Mounded Igloo

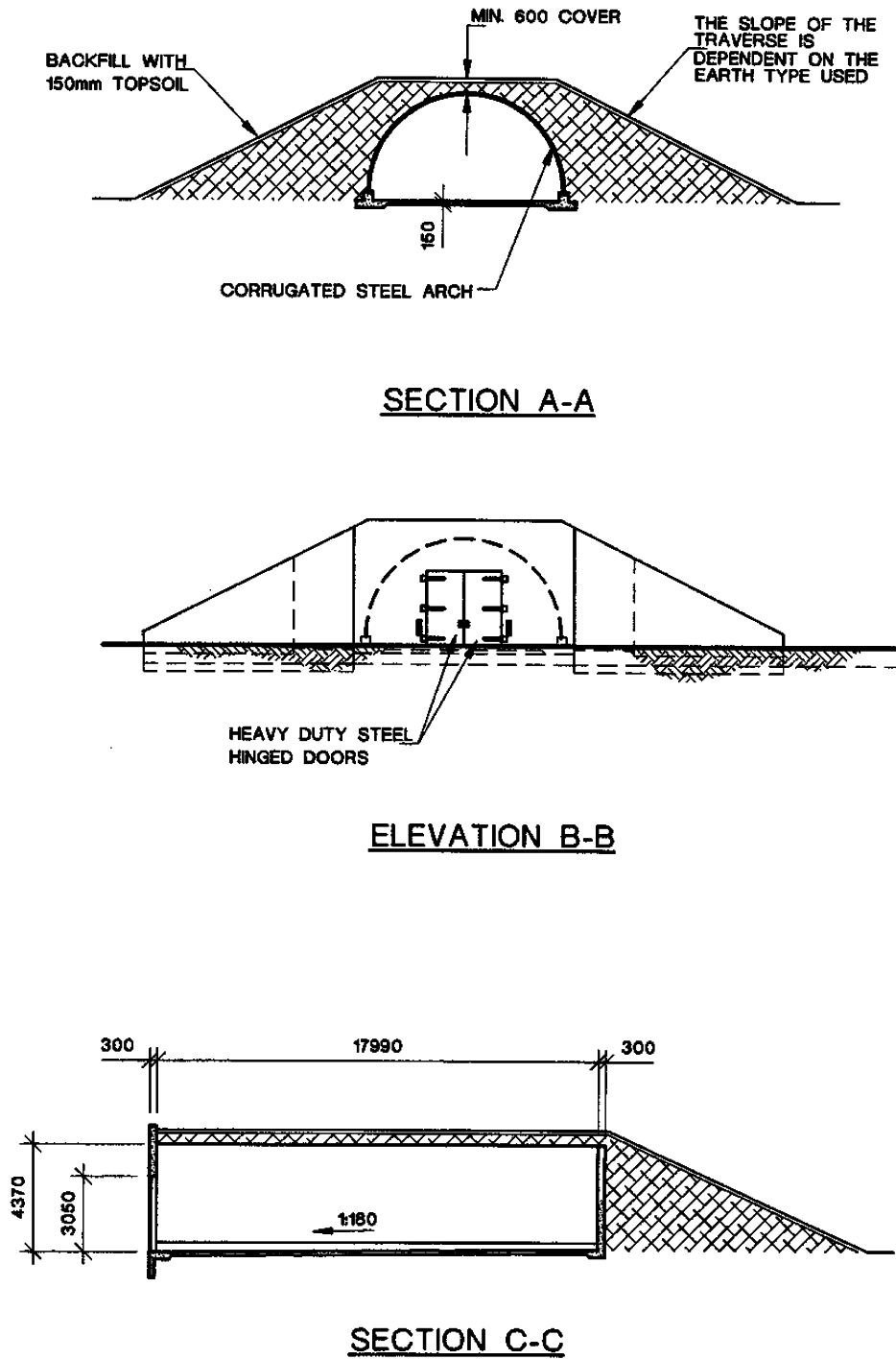

Fig 8 Typical Storehouse - Steel Arch Earth Mounded Igloo

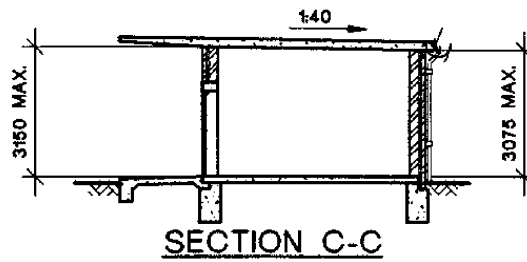
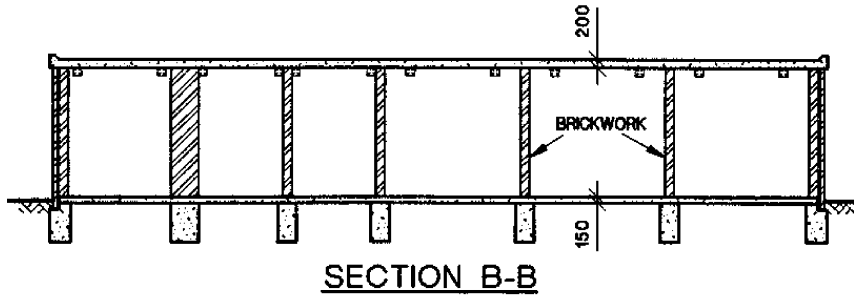
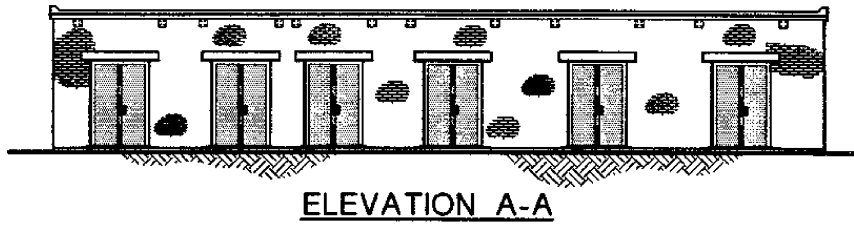
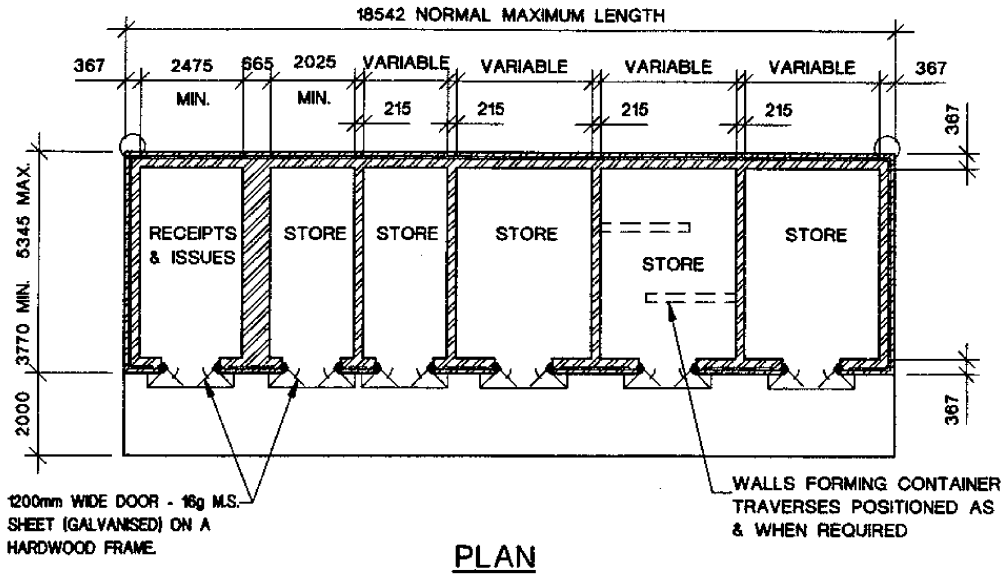

Fig 9 Standard Storehouse - Unit Ammunition Store

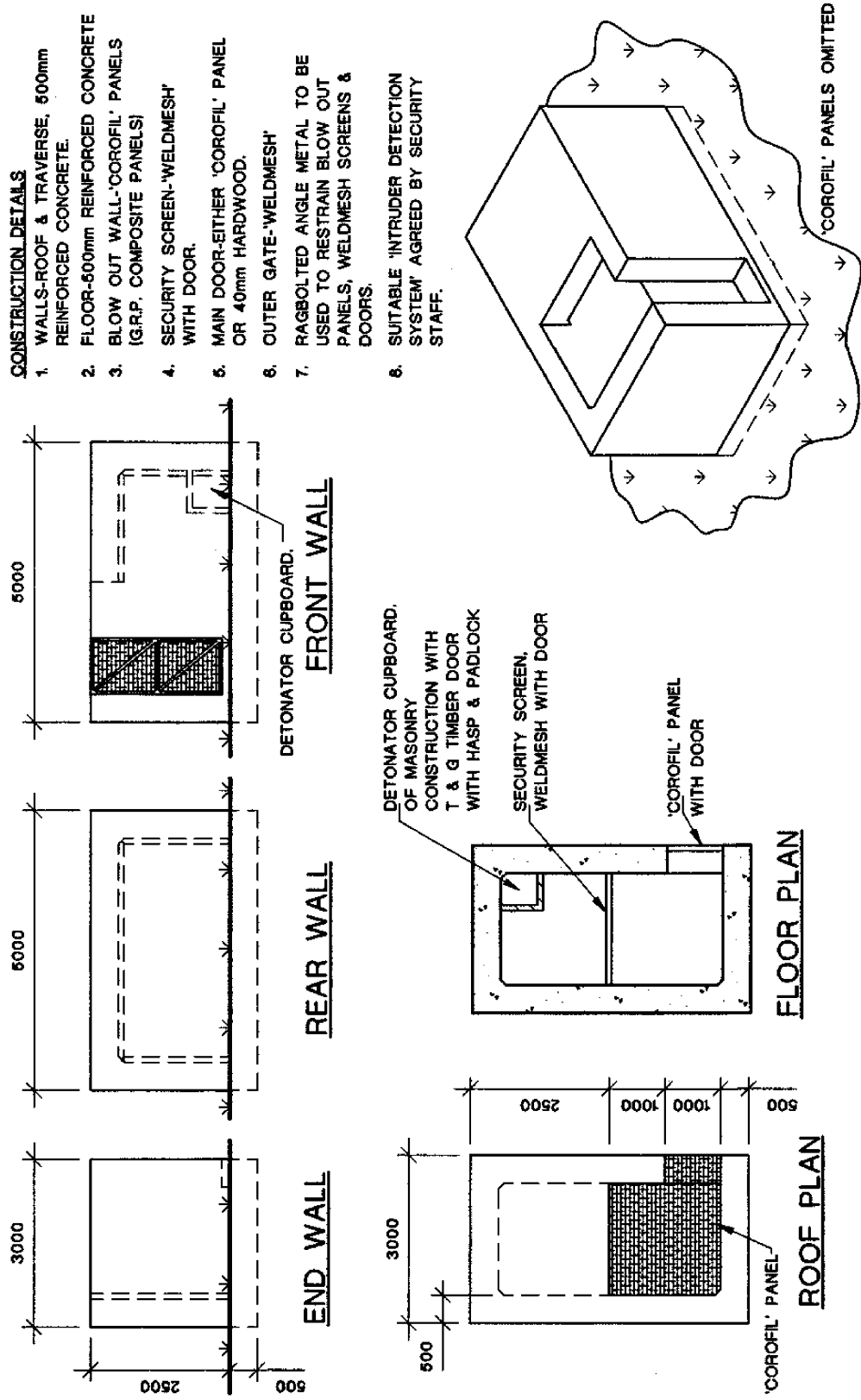

Fig 10 Standard Storehouse - 'TO' Type Explosives Store

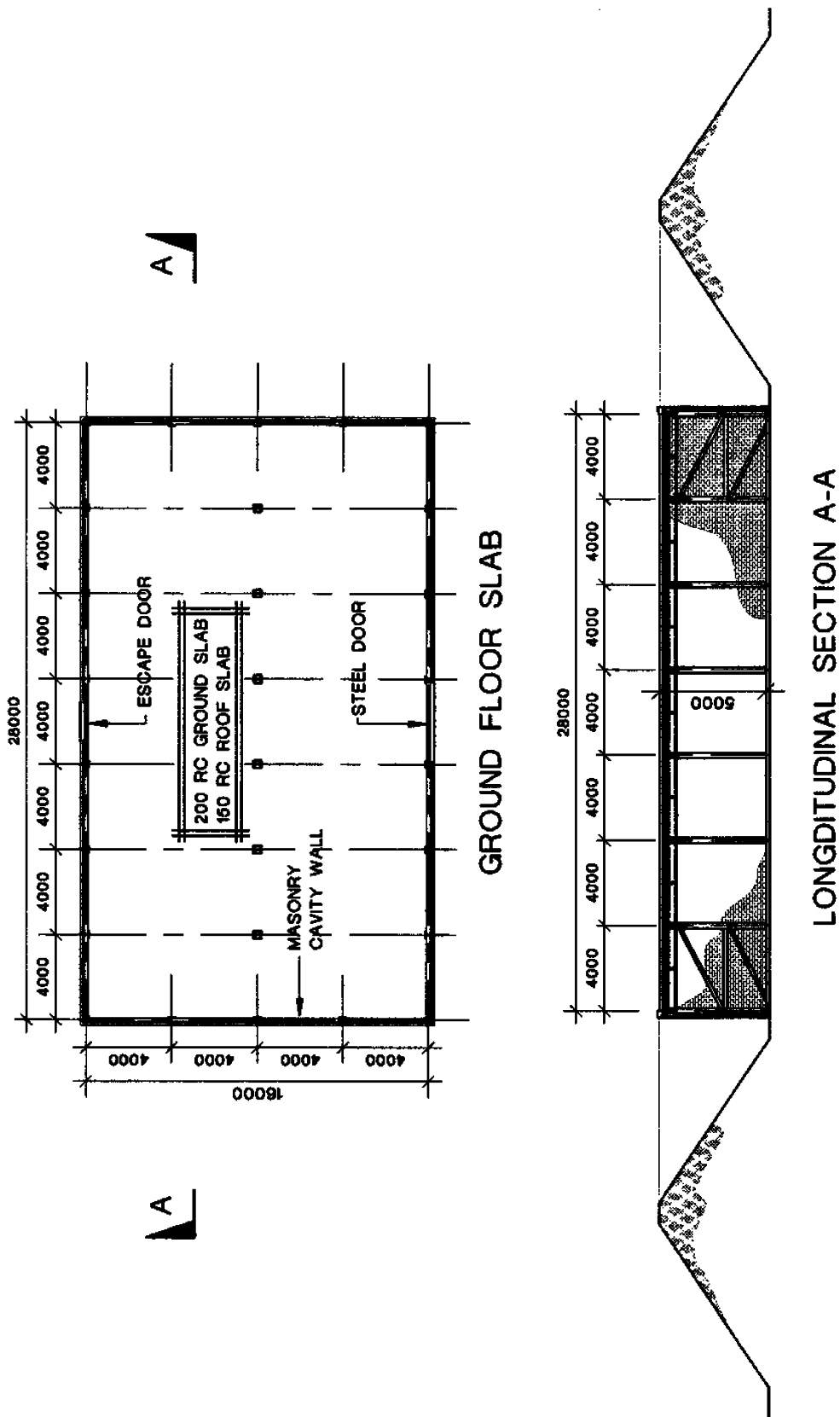

Fig 11 Typical Storehouse - Steel Framed Medium Walled ESH

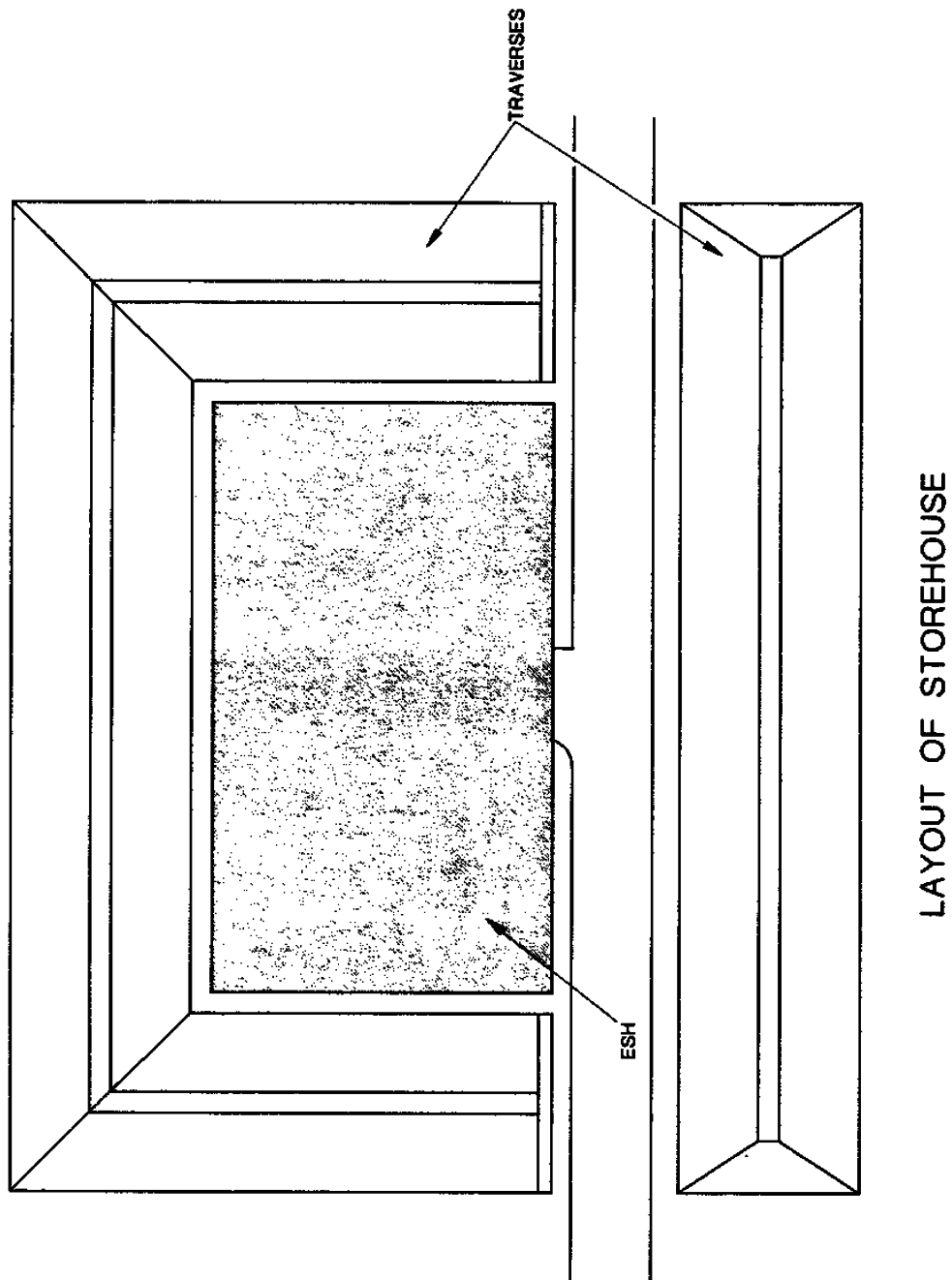

Fig 12 Typical Storehouse - Steel Framed Medium Walled ESH

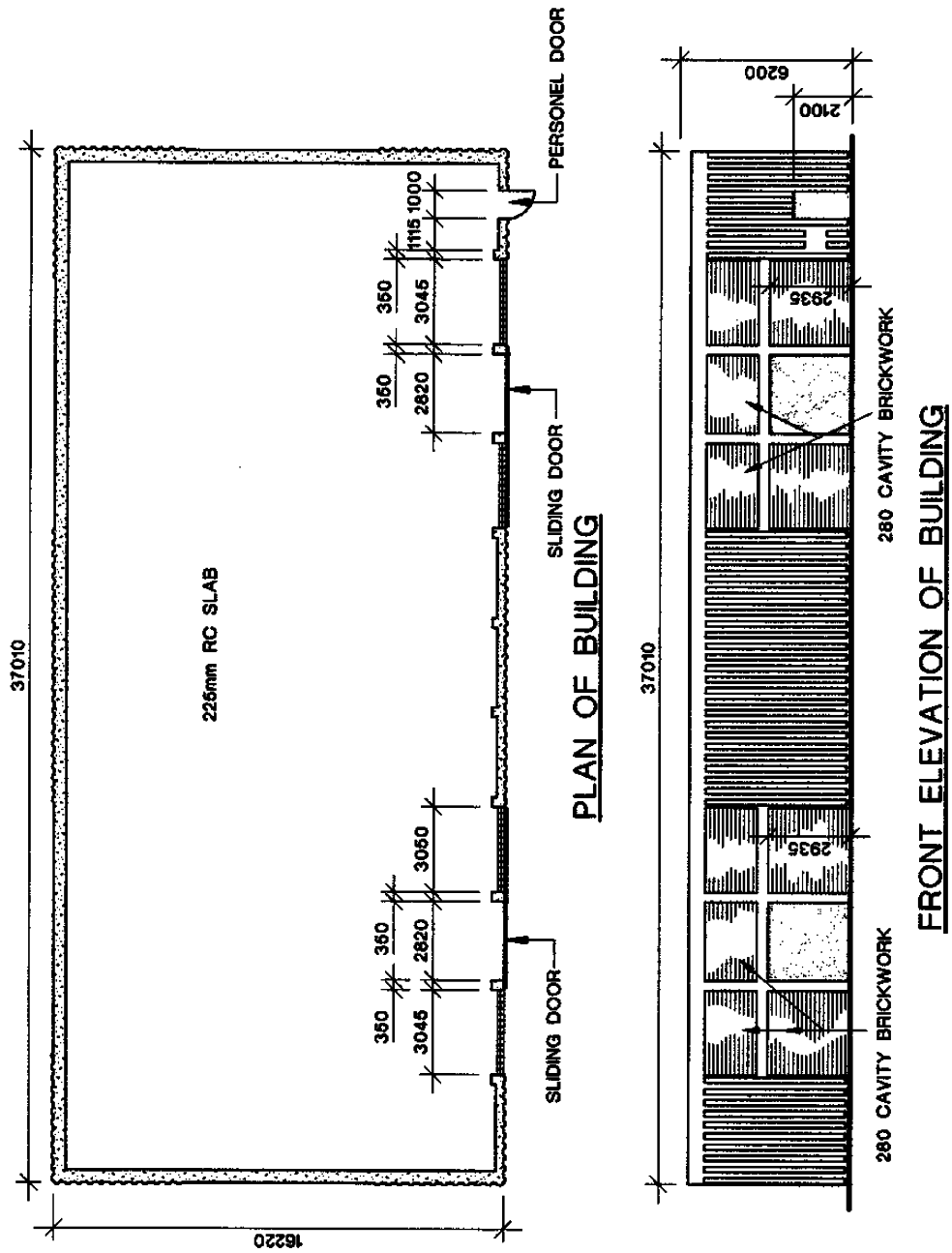

Fig 13 Typical Storehouse - ESH for HD 1.3 Explosives

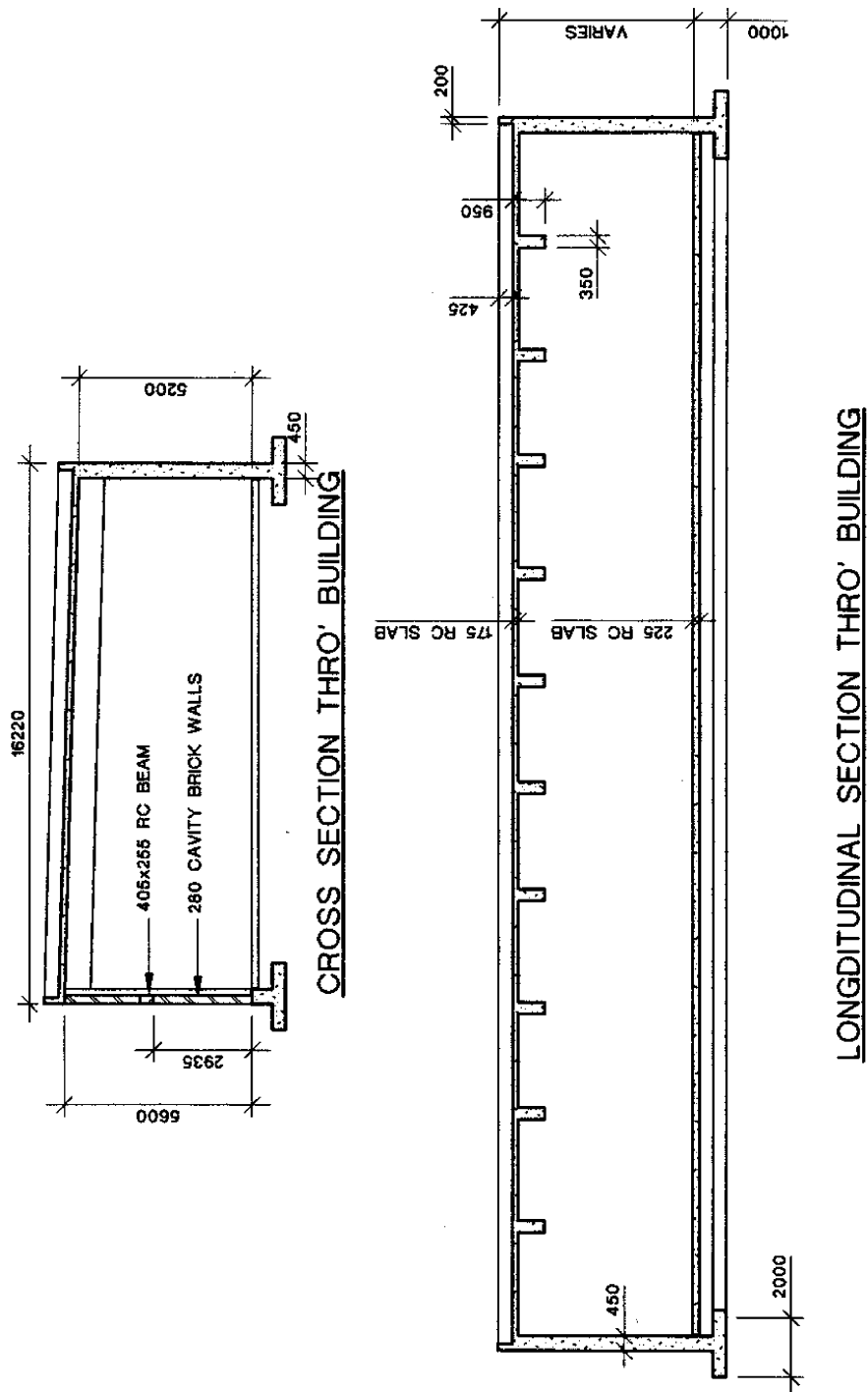

Fig 14 Typical Storehouse - ESH for HD 1.3 Explosives

Intentional Blank Page

CHAPTER 6**ANNEX A****APPENDIX 2****TYPICAL PROCESS BUILDINGS****CONTENTS**

Fig		Page
1	Typical Ammunition Process Building (Plan)	56
2	Typical Ammunition Process Building (Elevation)	57
3	Typical Process Building - Ammunition Test Building (Plan/Elevation)	58
4	Typical Process Building - Ammunition Test Building (Plan)	59
5	Typical Process Building - Guided Weapon Workshop and Store (Plan)	60
6	Typical Process Building - Guided Weapon Workshop and Store (Elevation)	61
7	Typical Process Building (Plan/Elevation)	62
8	Standard Process Building - Integrated Weapons Complex (Plan 1)	63
9	Standard Process Building - Integrated Weapons Complex (Plan 2)	64
10	Standard Process Building - Integrated Weapons Complex (Plan/Elevation)	65

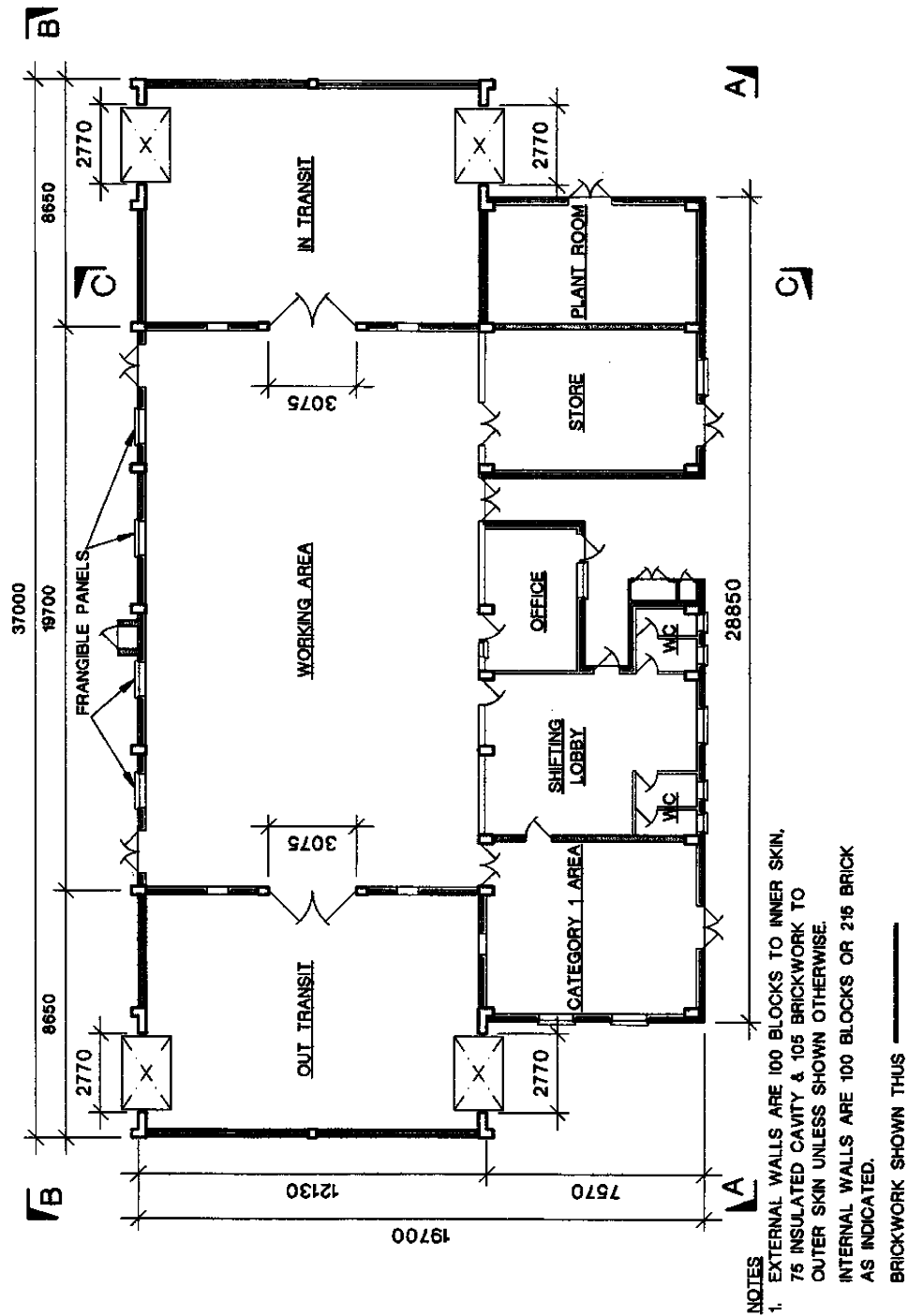

Fig 1 Typical Ammunition Process Building (Plan)

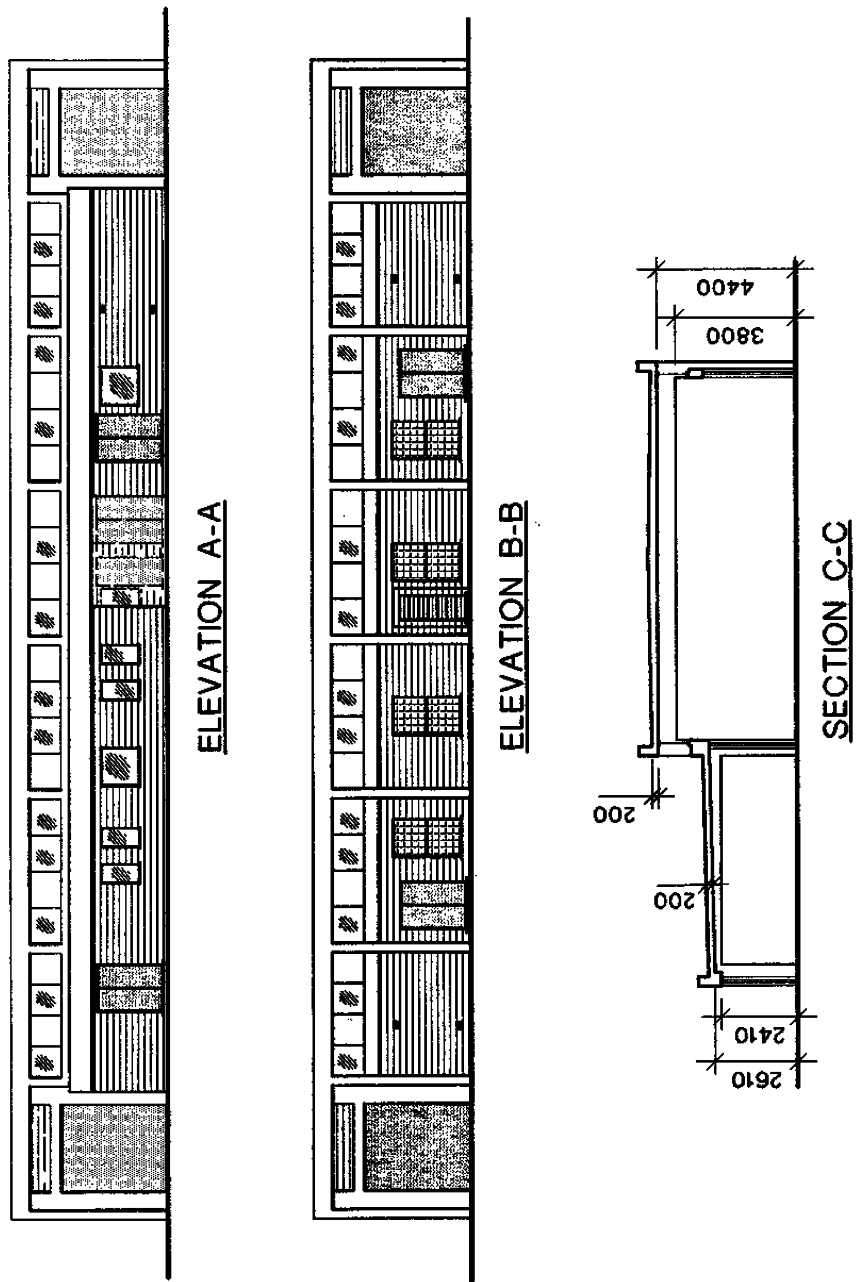

Fig 2 Typical Ammunition Process Building (Elevation)

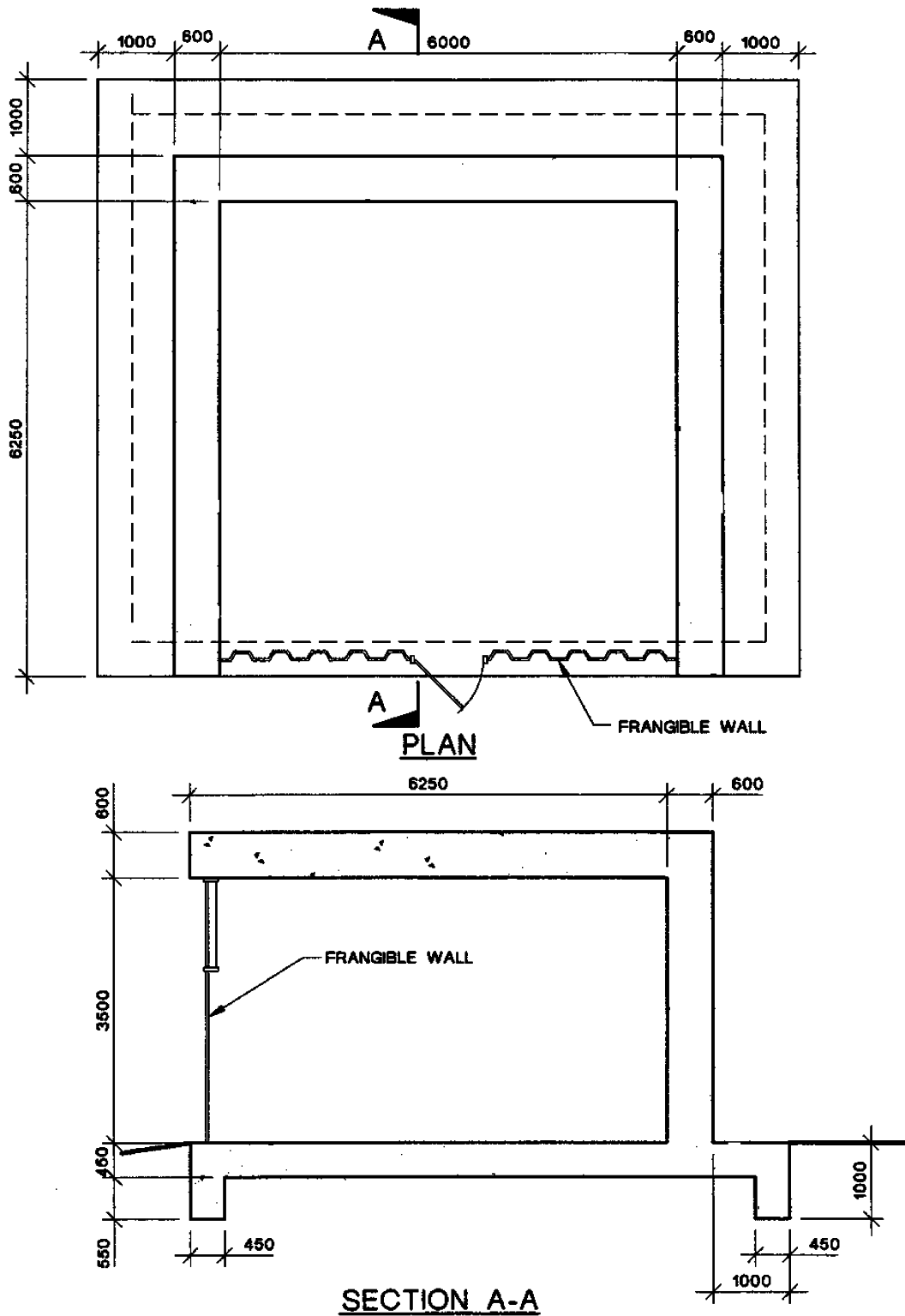
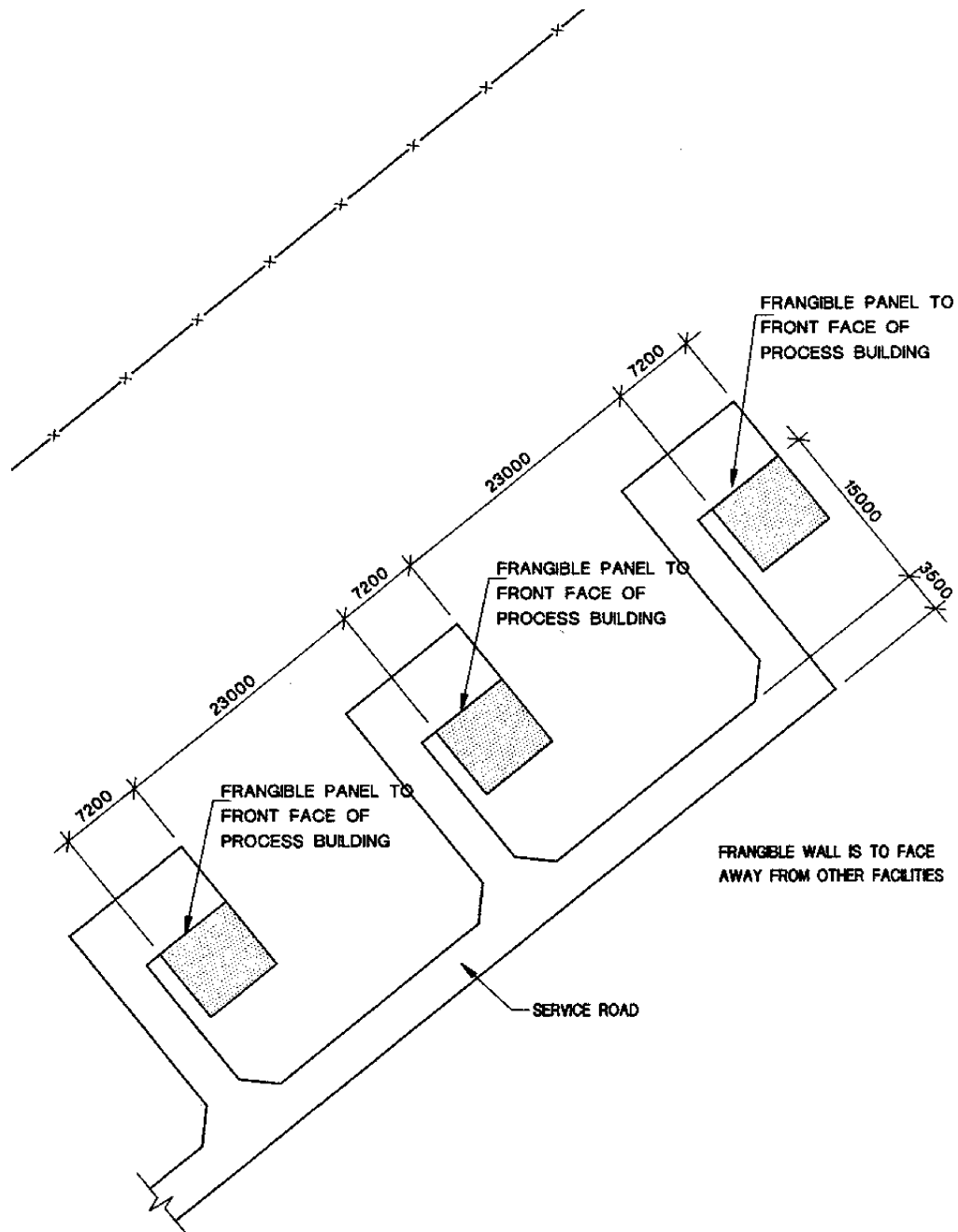

Fig 3 Typical Process Building - Ammunition Test Building (Plan/Elevation)



LAYOUT OF A TYPICAL FACILITY

Fig 4 Typical Process Building - Ammunition Test Building (Plan)

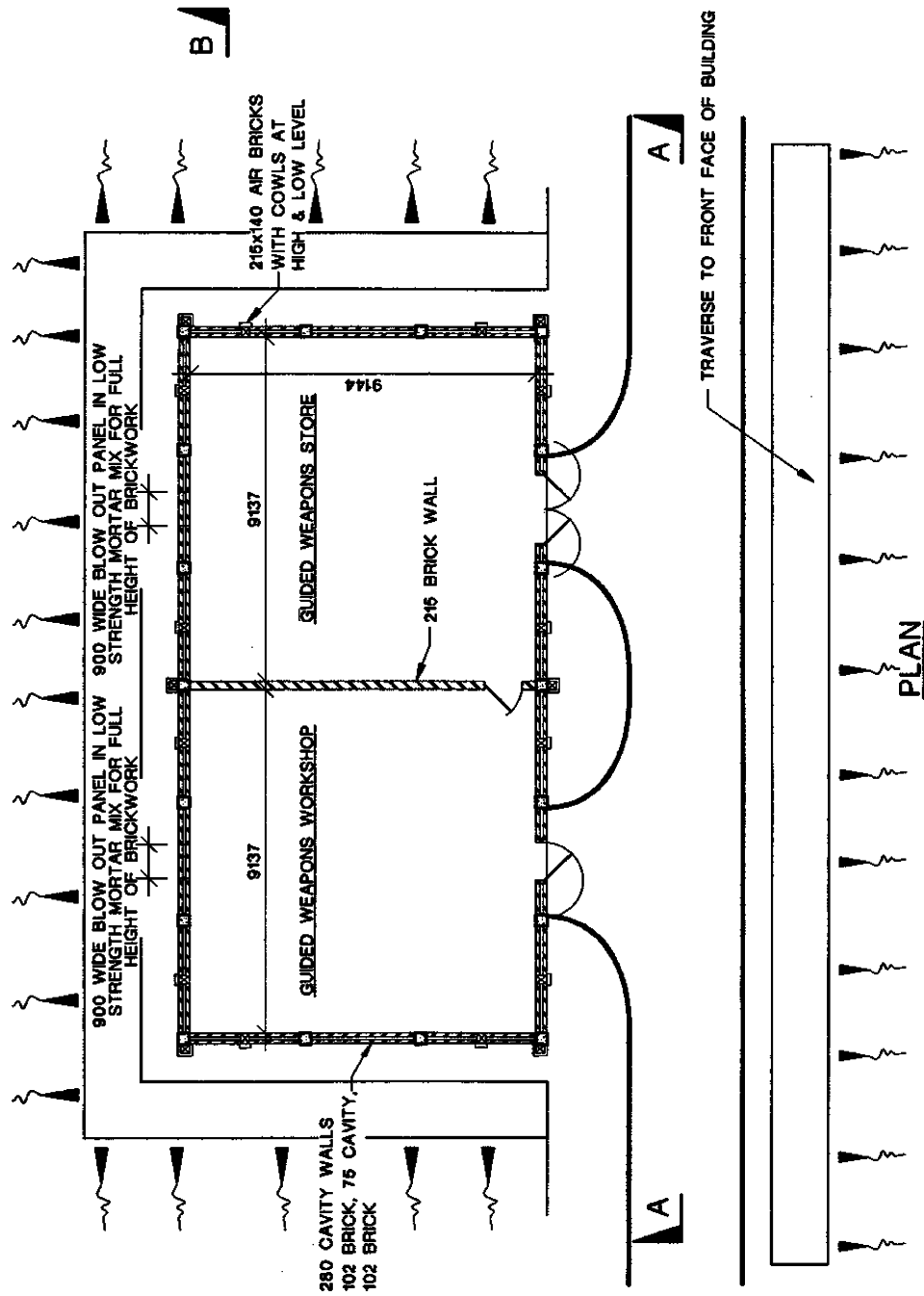

Fig 5 Typical Process Building - Guided Weapon Workshop and Store (Plan)

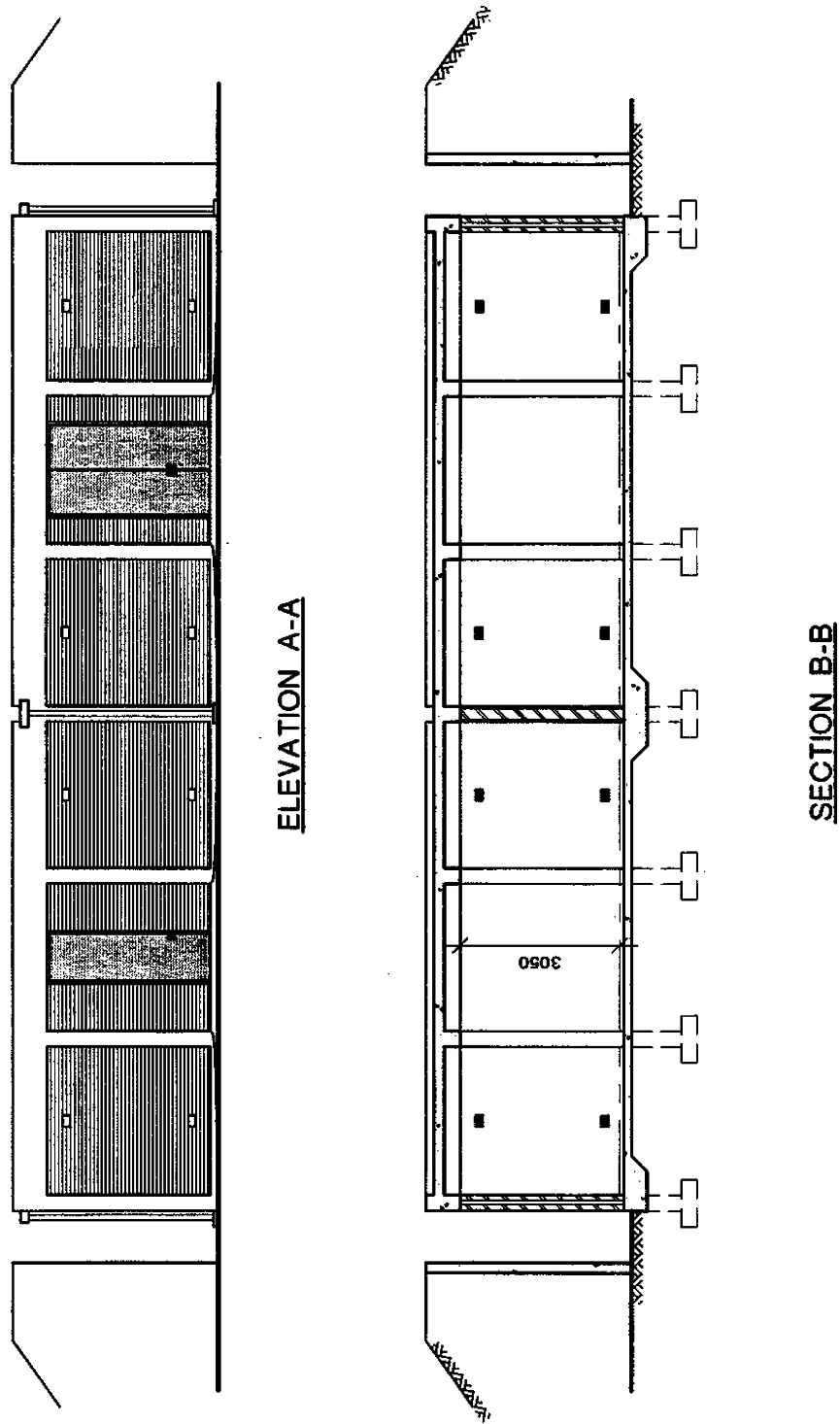

Fig 6 Typical Process Building - Guided Weapon Workshop and Store (Elevation)

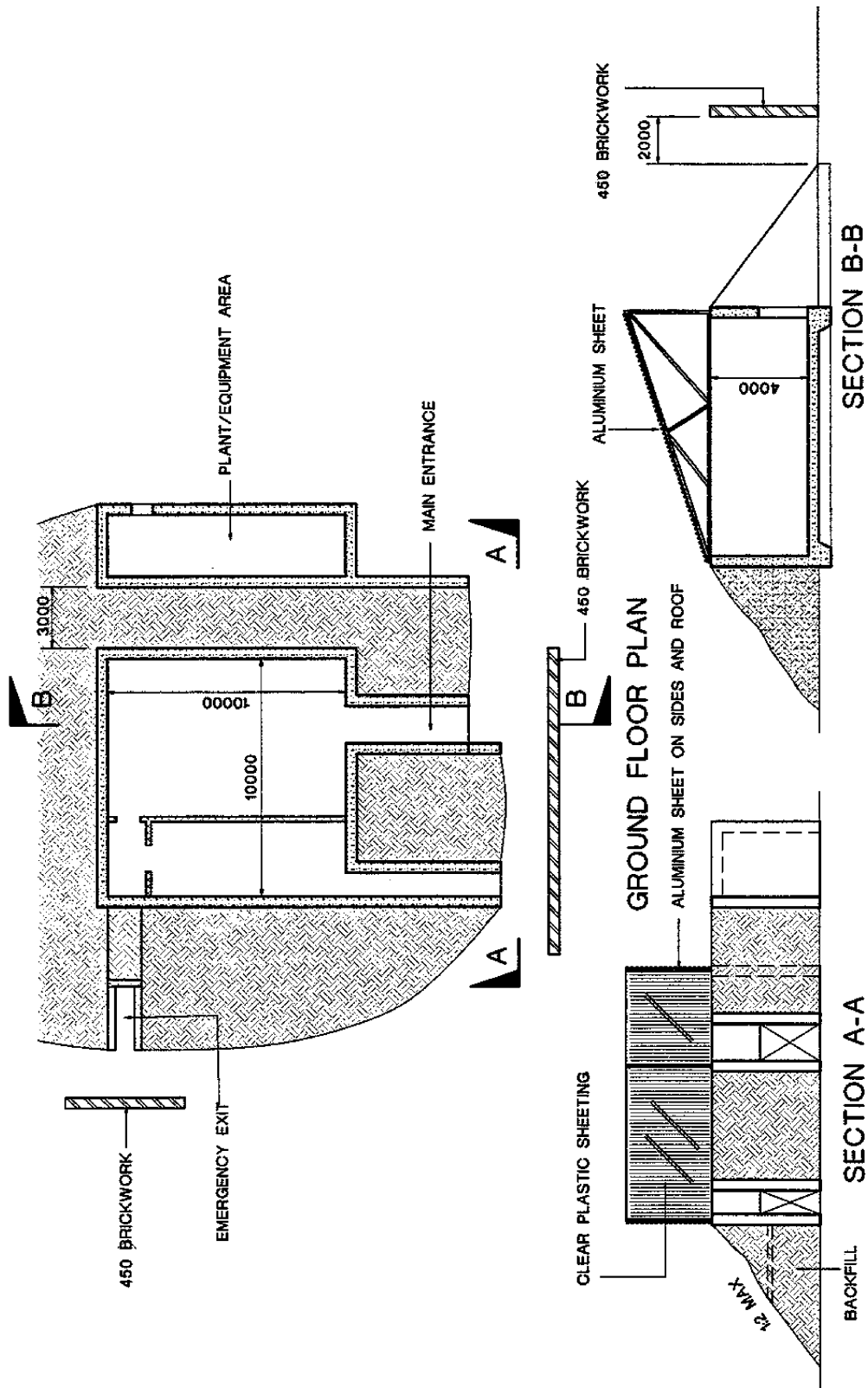

Fig 7 Typical Process Building (Plan/Elevation)

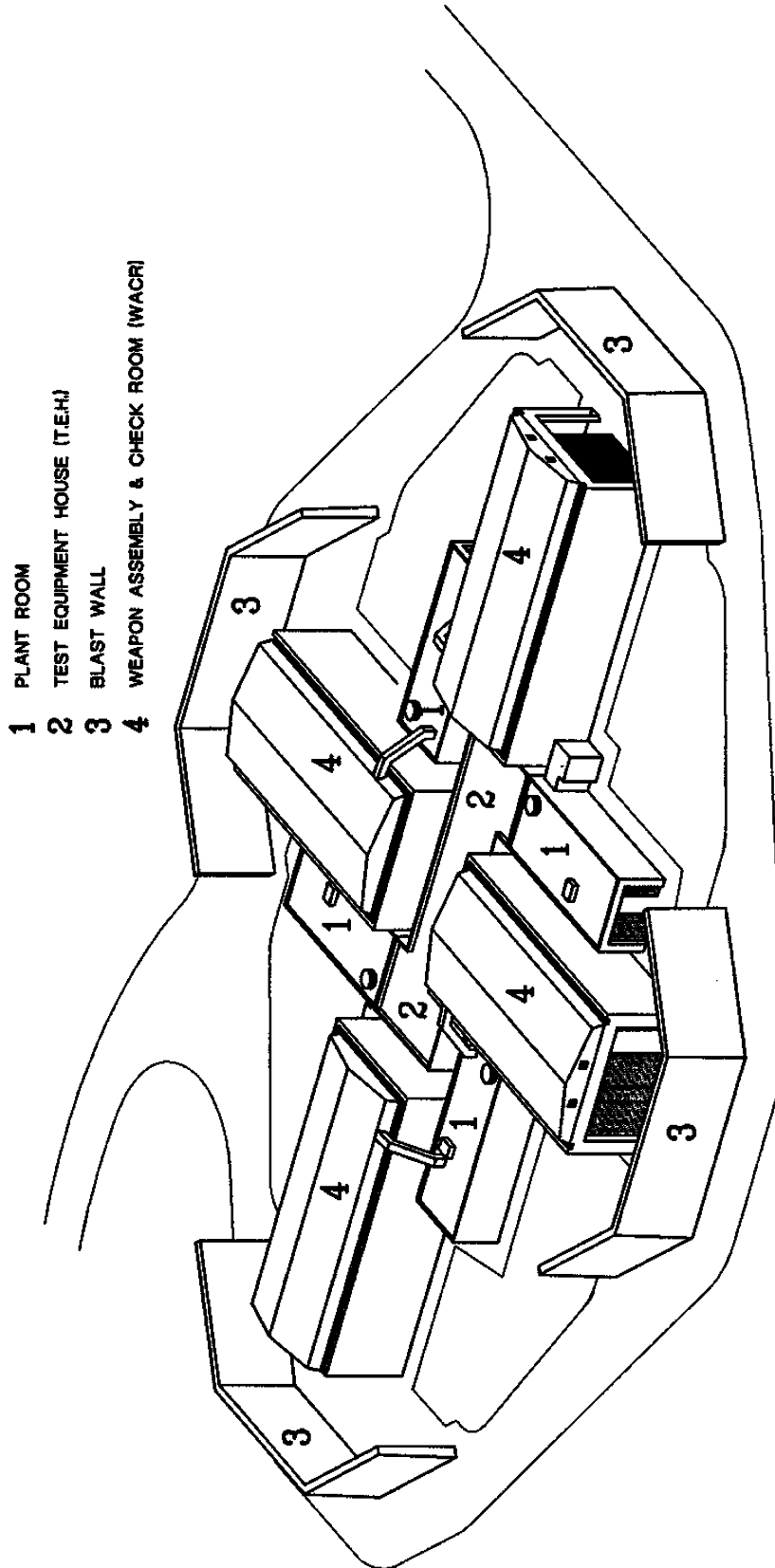

Fig 8 Standard Process Building - Integrated Weapons Complex (Plan 1)

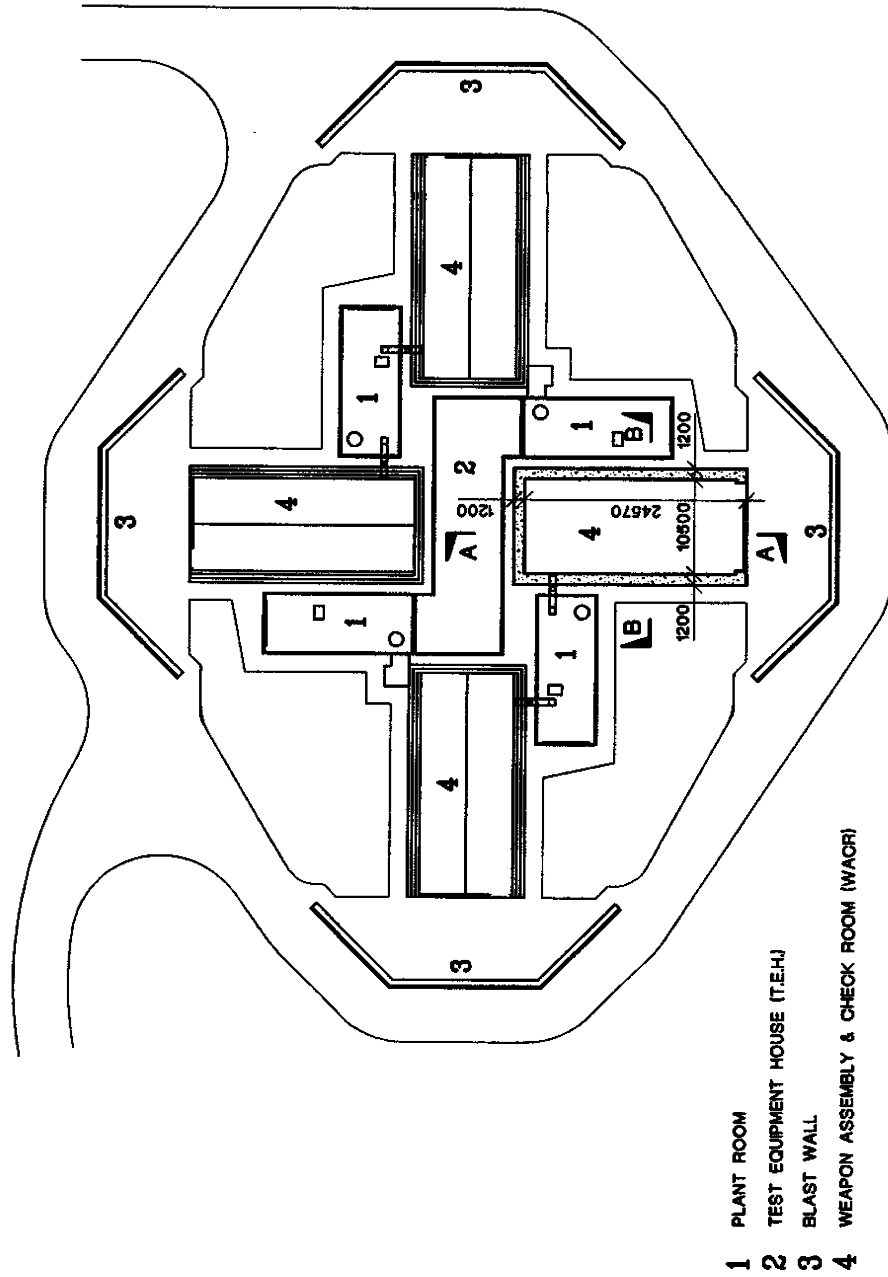

Fig 9 Standard Process Building - Integrated Weapons Complex (Plan 2)

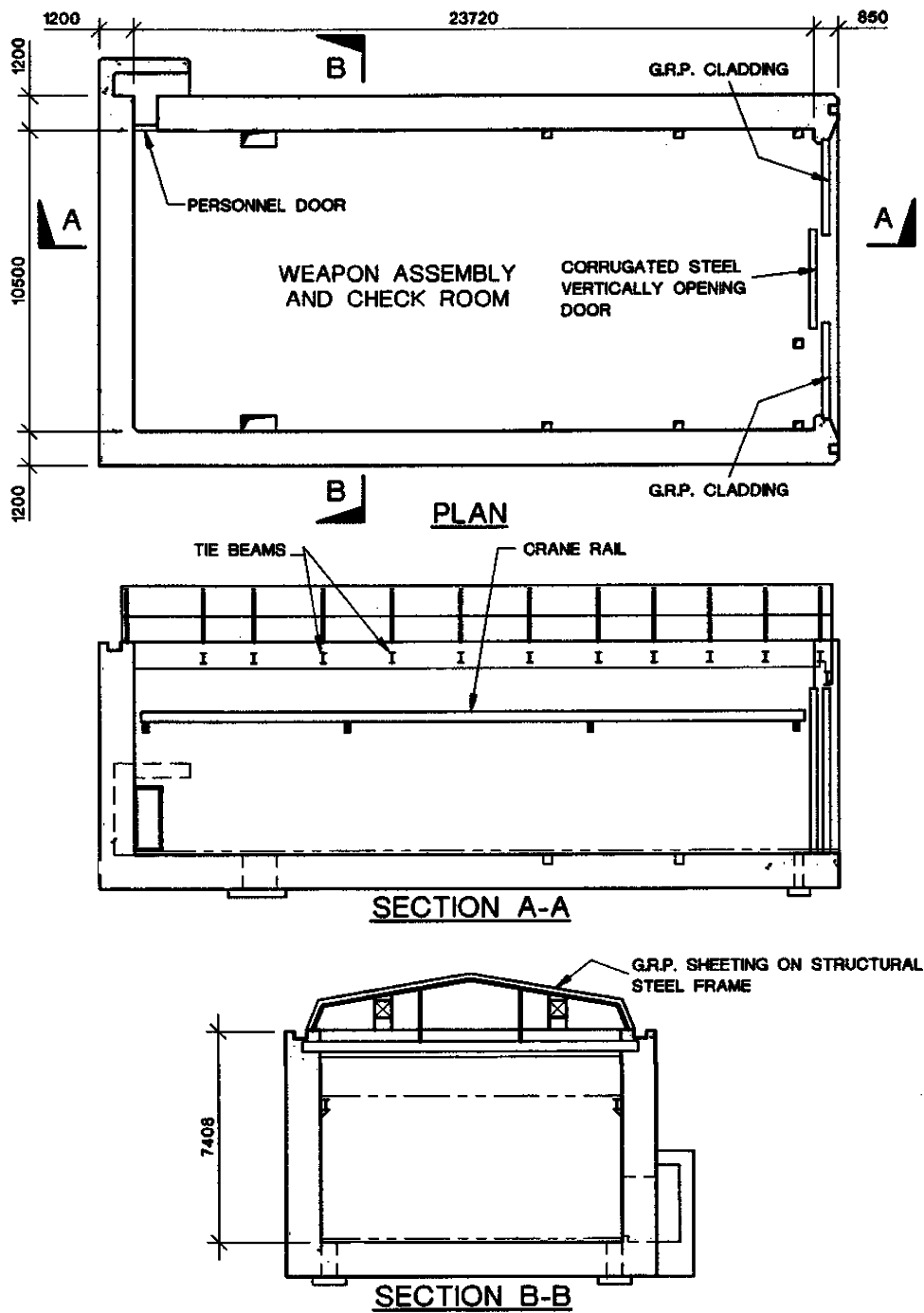

Fig 10 Standard Process Building - Integrated Weapons Complex (Plan/Elevation)

Intentional Blank Page

CHAPTER 6
ANNEX A
APPENDIX 3
BLOW-OUT PANELS

CONTENTS

Fig		Page
1	Typical Blow-out Panel	68
2	Alternative Blow-out Panel	69

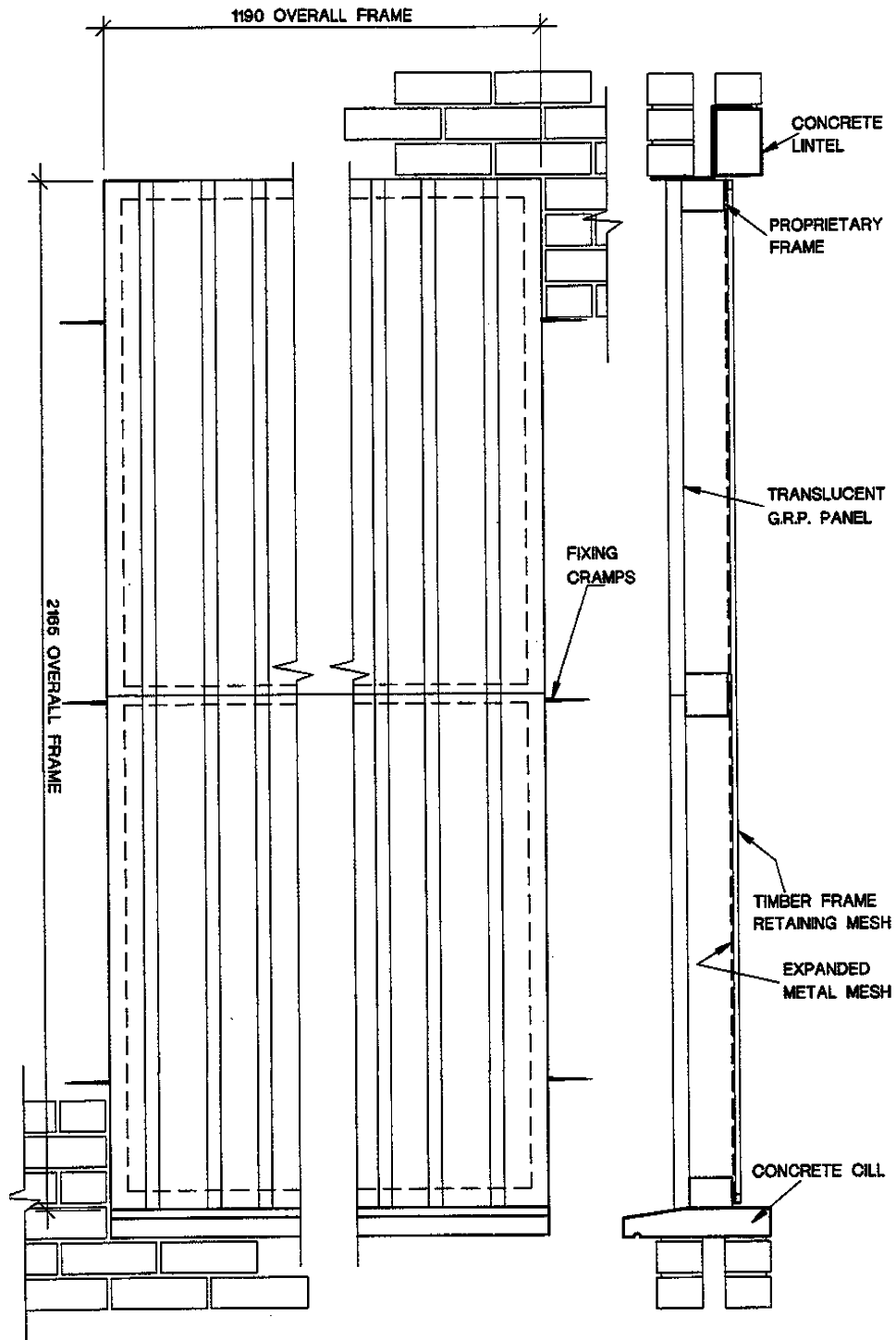

Fig 1 Typical Blow-out Panel

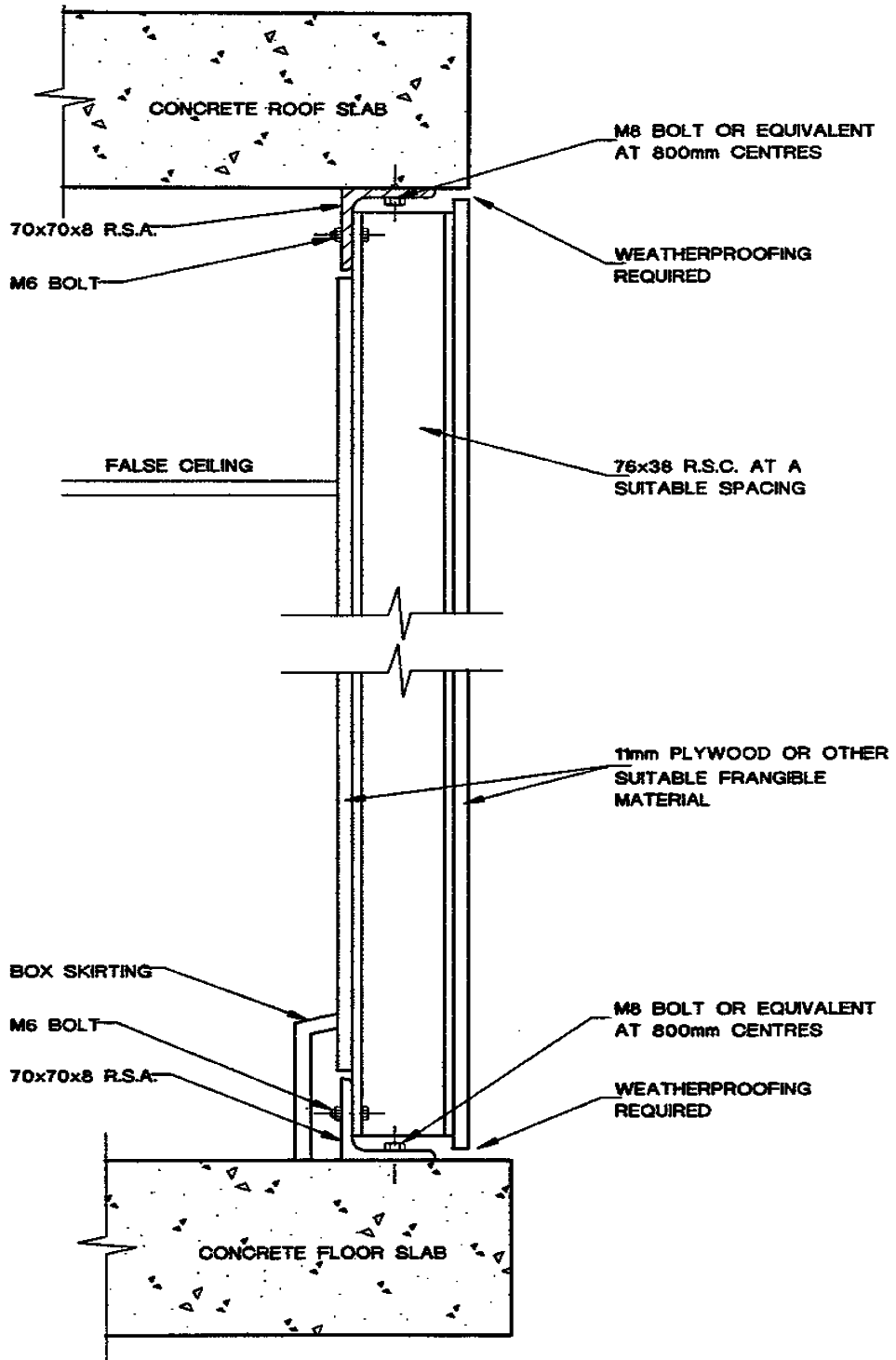

Fig 2 Alternative Blow-out Panel

Intentional Blank Page

CHAPTER 6

ANNEX A

APPENDIX 4

REINFORCEMENT AND BLAST LINK DETAILS

CONTENTS

Fig		Page
1	Typical Reinforcement Details	72
2	Typical Blast Link Details	73

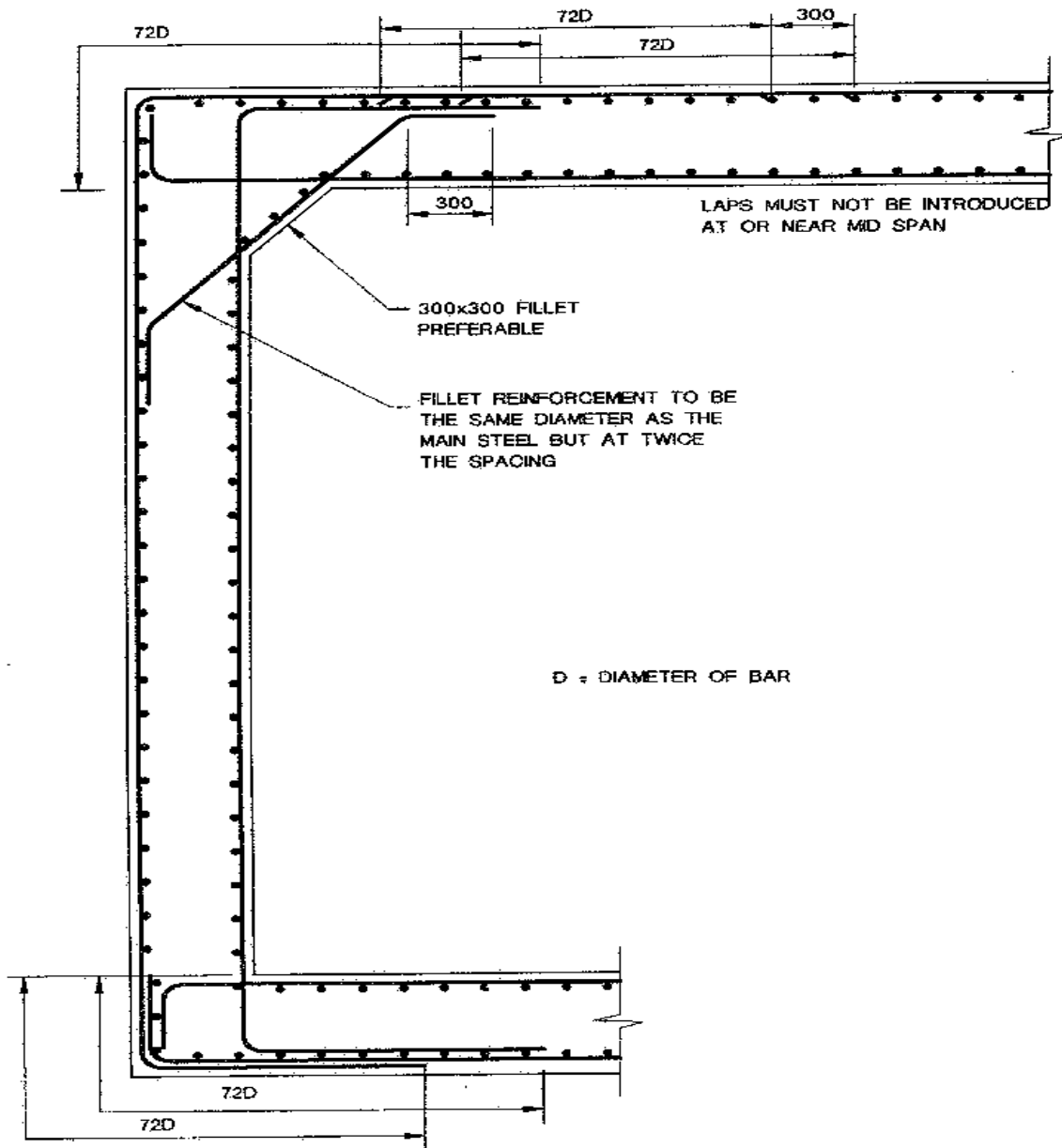
**NOTES**

1. CONTINUOUS REINFORCEMENT SHOULD BE USED. WHERE LAPS IN THE TOP REINFORCEMENT ARE CONSIDERED TO BE ABSOLUTELY NECESSARY THEY SHOULD BE LOCATED AT SPAN $\frac{1}{3}$ POINTS AND LAP LENGTH MUST BE 72D STAGGERED A MINIMUM OF 300mm.
2. REINFORCEMENT IS TO BE HOT ROLLED HIGH YIELD, OR MILD STEEL
3. OPEN LINKS MUST BE PROVIDED IN EXTERNAL WALLS AND ROOF SLAB, AS DETAILED ON FIGURE E2

Fig 1 Typical Reinforcement Details

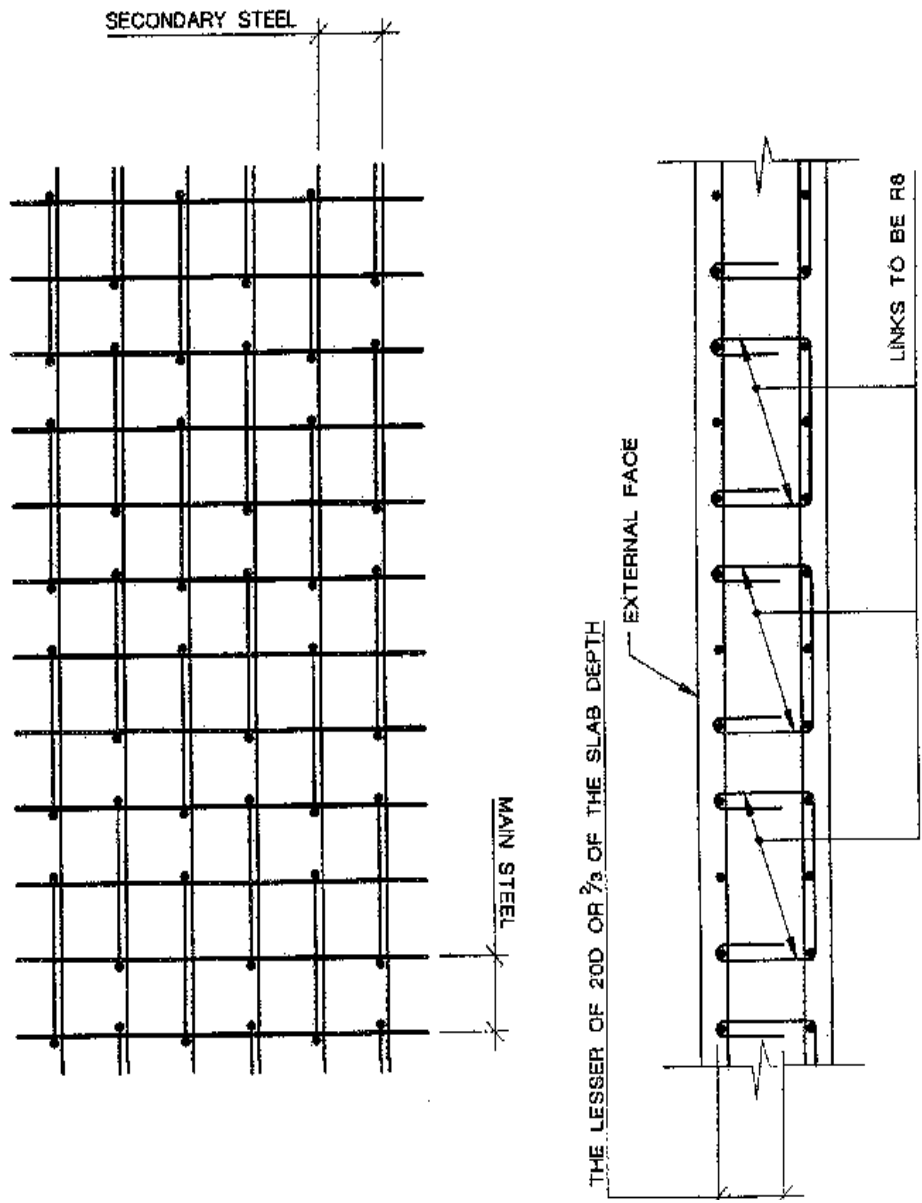

Fig 2 Typical Blast Link Details

Intentional Blank Page