

Drawing No.  
P 668.1

Related Drawings  
S 19, S 43 & P 668

Before using this drawing, confirm that it has not been superseded.

© CROWN COPYRIGHT

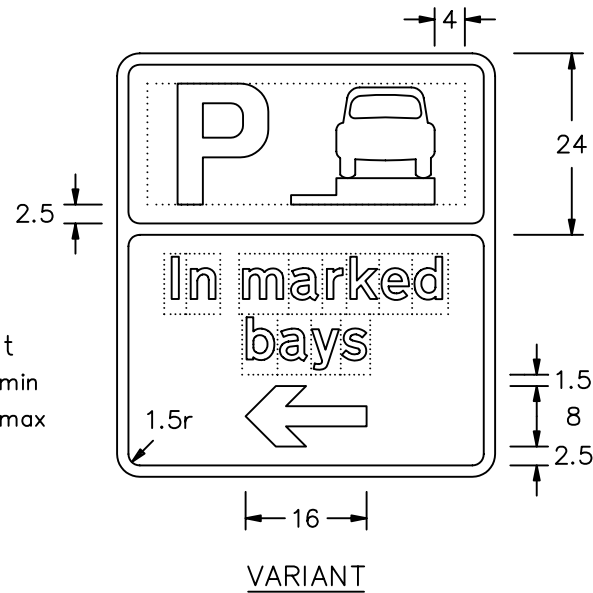
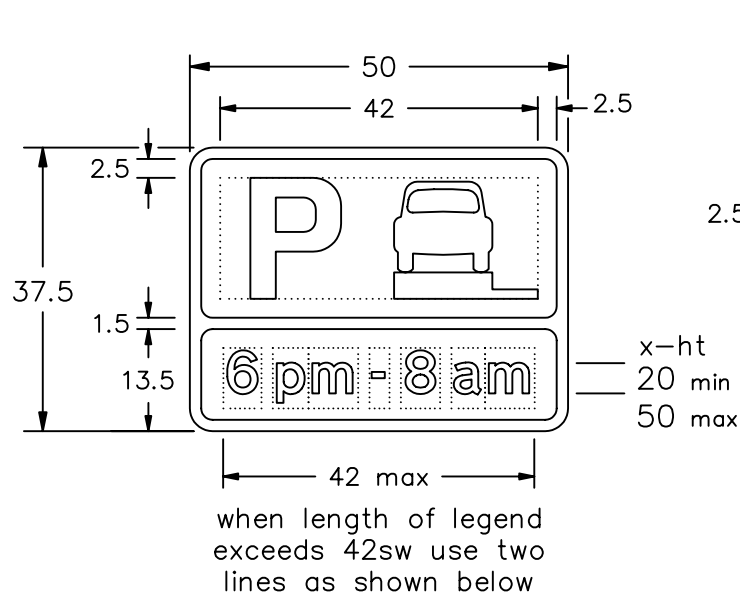

- NOTES: 1. The legend is from the Transport Medium alphabet at the x-heights shown.
2. Car symbol details are given on drawing S 19 and 'P' symbol details on drawing S 43. See drawing P 668 for 'car on footway' details.
3. The tile outlines do not form part of the signs.
4. COLOURS : Background ----- BLUE  
Legend & Border ---- WHITE  
Symbols & Arrow --- WHITE
5. DIMENSIONS : x-heights are in millimetres, other dimensions are in stroke widths. (4sw = x-ht)
6. See section 12 in Chapter 7 of the Traffic Signs Manual for further details of time plate design.

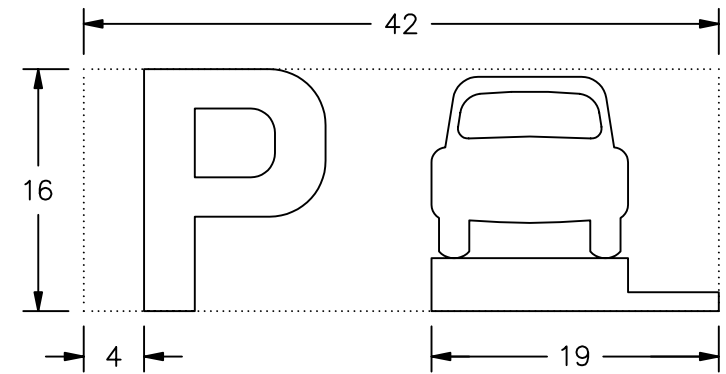
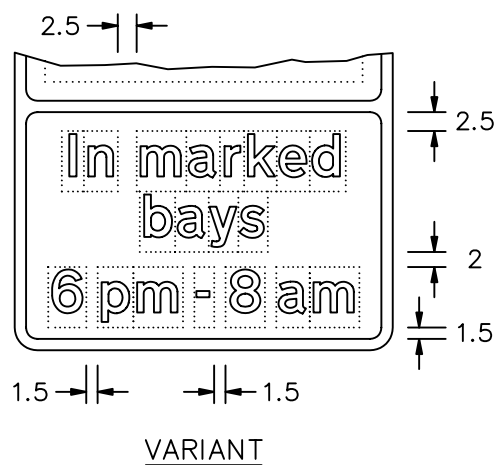
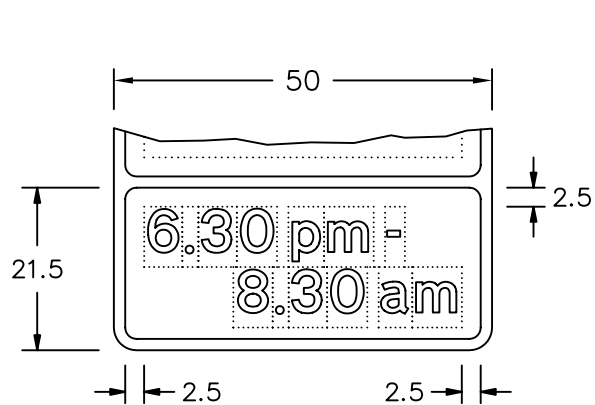

The 'car on footway' symbol is moved 4sw to the left when reversed in a mirror image (see variant above left)

P668x1

Department for  
**Transport**

Title: Regulatory Signs  
PARKING PLACE WHOLLY  
ON VERGE OR FOOTWAY

Issue: Date: Drawn by: Dimensions:  
A: 4.7.94 S.P.  
B: 16.8.04 Approved by:  
C: R.M.

SEE  
NOTE 5

Drawing No.  
P 668.1