



Ministry
of Defence

de&s

DE&S Secretariat (Land Equipment)

DESSEC-PolSecLE-JSC-WPNS@mod.uk

Defence Equipment & Support
Maple 0a # 2043
MOD Abbey Wood
Bristol BS34 8JH



Via:

30th May 2019 Our Ref: FOI2019/04714

Dear [REDACTED],

Thank you for your email of 15th April 2019 requesting the following information:

*I am looking for AESP 2320-D-128-411 document (pdf) for my ex MoD Land Rover.
Could you please provide that file?*

I am treating your correspondence as a request for information under the Freedom of Information Act 2000 (FOIA).

A search for the information has now been completed within the Ministry of Defence, and I can confirm that information in scope of your request is held.

The information you have requested can be found below, but some of the information falls entirely within the scope of the qualified exemptions provided for at sections 26 (Defence) and 38 (Health and Safety) of the FOIA and has been redacted.

Sections 26 and 38 are qualified exemptions and are subject to public interest testing which means that the information requested can only be withheld if the public interest in doing so outweighs the public interest in disclosure.

Section 26(1)(b) has been applied to some of the information because it contains details which are operationally sensitive and would prejudice the capability and effectiveness of our armed forces. The balance of public interest was found to be in favour of withholding the information given that, overall, the public interest is best served in not releasing any details that would prejudice the security of UK personnel and which would provide tactical advantage to our enemies. For these reasons I have set the level of prejudice against release of the exempted information at the higher level of "would" rather than "would be likely to".

Section 38 has been applied because some of the information has the potential to adversely affect the physical and/or mental health of UK personnel as well as endanger the safety of an individual by exposing vulnerabilities. The balance of the public interest test concluded that, whilst release would increase public understanding and confidence, the balance of the public interest lay in withholding this information you desire. I have considered it necessary to apply the higher level of prejudice against release of the exempted information at the higher level of "would" rather than "would be likely to".

If you have any queries regarding the content of this letter, please contact this office in the first instance.

If you wish to complain about the handling of your request, or the content of this response, you can request an independent internal review by contacting the Information Rights Compliance team, Ground

Defence Equipment & Support

Floor, MOD Main Building, Whitehall, SW1A 2HB (e-mail CIO-FOI-IR@mod.gov.uk). Please note that any request for an internal review should be made within 40 working days of the date of this response.

If you remain dissatisfied following an internal review, you may raise your complaint directly to the Information Commissioner under the provisions of Section 50 of the Freedom of Information Act. Please note that the Information Commissioner will not normally investigate your case until the MOD internal review process has been completed. The Information Commissioner can be contacted at: Information Commissioner's Office, Wycliffe House, Water Lane, Wilmslow, Cheshire, SK9 5AF. Further details of the role and powers of the Information Commissioner can be found on the Commissioner's website at <https://ico.org.uk/>.

Yours sincerely,

DES SEC Pol Sec Land Equipment



**FOR OFFICIAL USE ONLY
CROWN COPYRIGHT RESERVED**

CONDITIONS OF RELEASE

- 1 ~~This information is released by the UK Government for Defence purposes only.~~
- 2 ~~This information must be accorded the same degree of security protection as that accorded thereto by the UK government.~~
- 3 ~~This information may be disclosed only within the Defence Department of that recipient Government, except as otherwise authorized by the ministry of Defence (Army).~~
- 4 This information may be subject to privately owned rights.

**TRUCK UTILITY LIGHT (TUL) HS
TRUCK UTILITY MEDIUM (TUM) HS
AND (TUM) AMBULANCE HS**

**INSTALLATION INSTRUCTIONS
AND INDEX**

BY COMMAND OF THE DEFENCE COUNCIL

Kevin T. Brown

Ministry of defence
Issued by

**ARMY TECHNICAL SUPPORT AGENCY
DIRECTORATE OF TECHNICAL SERVICES**

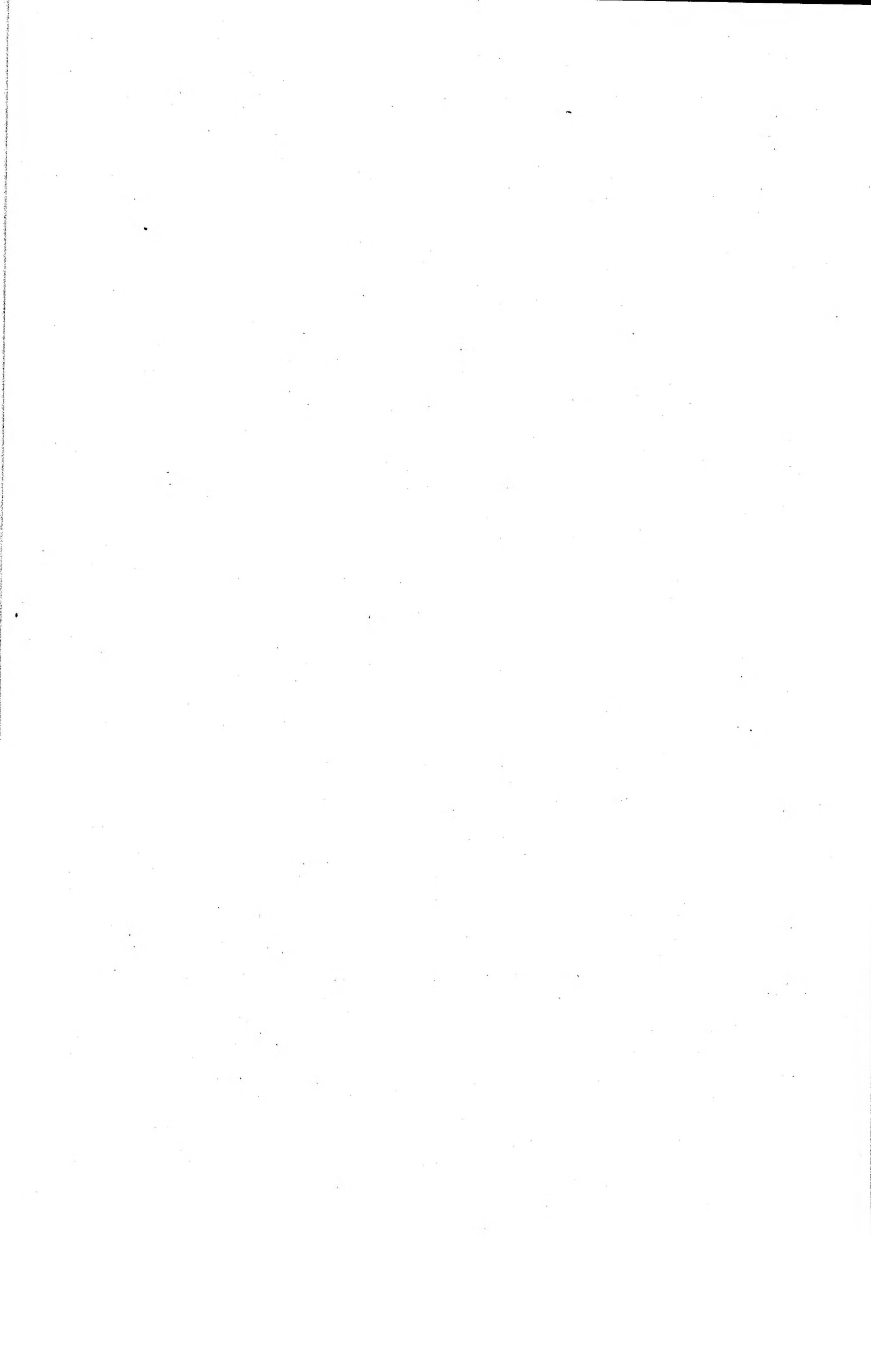

AMENDMENT RECORD

Amdt No.	Incorporated By (Signature)	Date	Amdt No.	Incorporated By (Signature)	Date
1			32		
2			33		
3			34		
4			35		
5			36		
6			37		
7			38		
8			39		
9			40		
10			41		
11			42		
12			43		
13			44		
14			45		
15			46		
16			47		
17			48		
18			49		
19			50		
20			51		
21			52		
22			53		
23			54		
24			55		
25			56		
26			57		
27			58		
28			59		
29			60		
30			61		
31			62		



PREFACE

Sponsor:

DGES(A) ES52
File ref: D/DGES(A) 548/3/4

Publication Agency:

ATSA Chertsey
Project No:ES52c/4356

INTRODUCTION

- 1 The Publications Agency is responsible for the allocation of instruction numbers.
- 2 All Preparation for Installation instructions as issued are to be recorded in manuscript by the recipient on the Installation Instruction Index provided. Amendments to individual instructions are to be recorded on the instruction Amendment Record. All extant instructions and amendments can be found listed in the main AESP index.
- 3 Service users should forward any comments on this publication through the channels prescribed in AESP 0100-P-011-013. An AESP Form 10 is provided after the preliminary pages of this publication; it should be photocopied and used for forwarding comments on this AESP.
- 4 AESPs are issued under Defence Council authority and where AESPs specify action to be taken, the AESP will of itself be sufficient authority for such action and also for the demanding of the necessary stores.

INSTALLATION INSTRUCTION INDEX

The index is to be kept up to date by the User entering Installation instructions as and when they are published.

Instr No. (1)	Subject (2)
1	
2	
3	Fitting of sand channel mounting brackets
4	Fitting of front axle guard
5	Fitting of GPMG barrel clamps
6	Fitting of an additional Spare Wheel Carrier
7	
8	Installation of 12/24 volt sockets
9	
10	
11	
12	

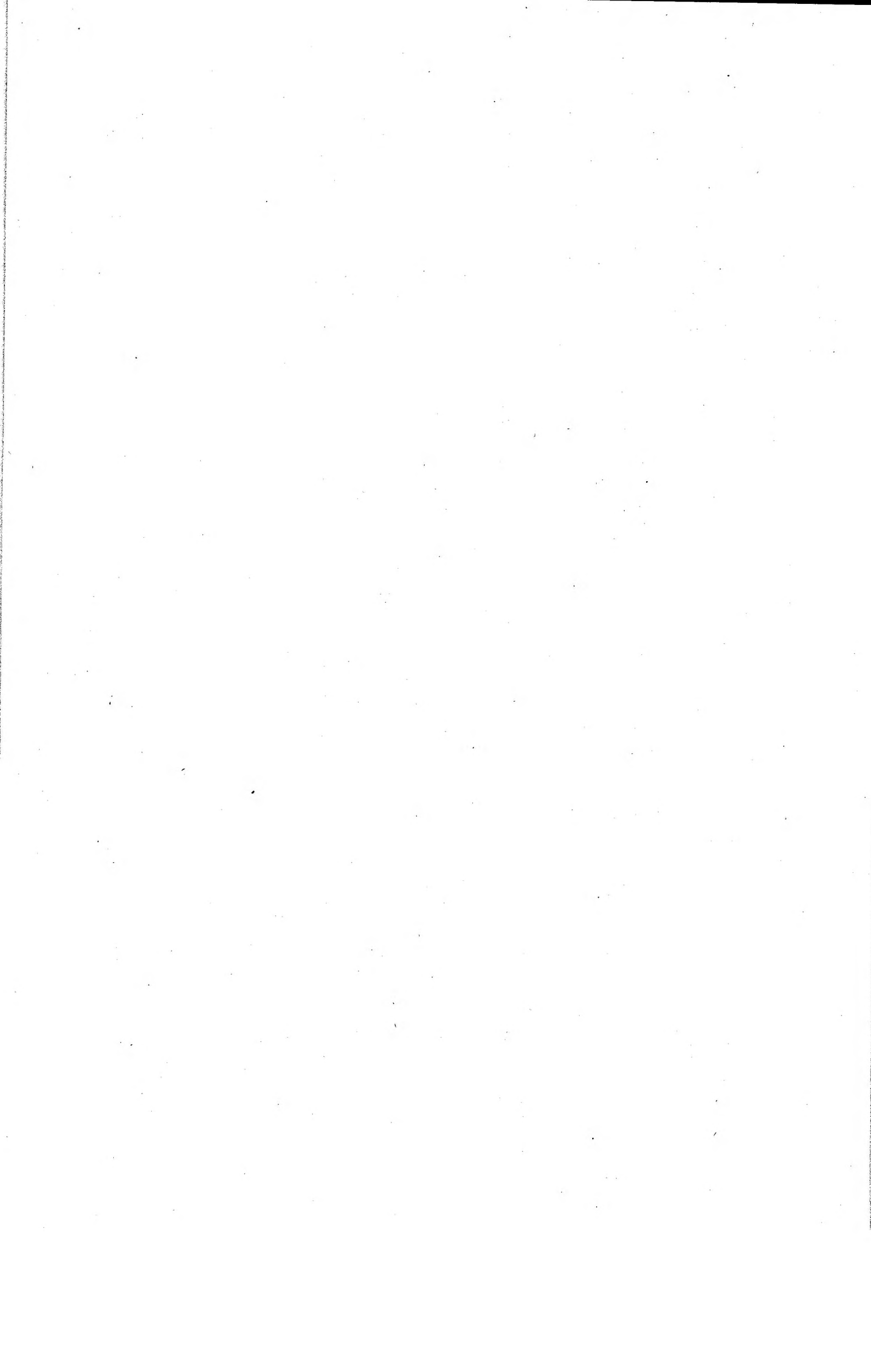

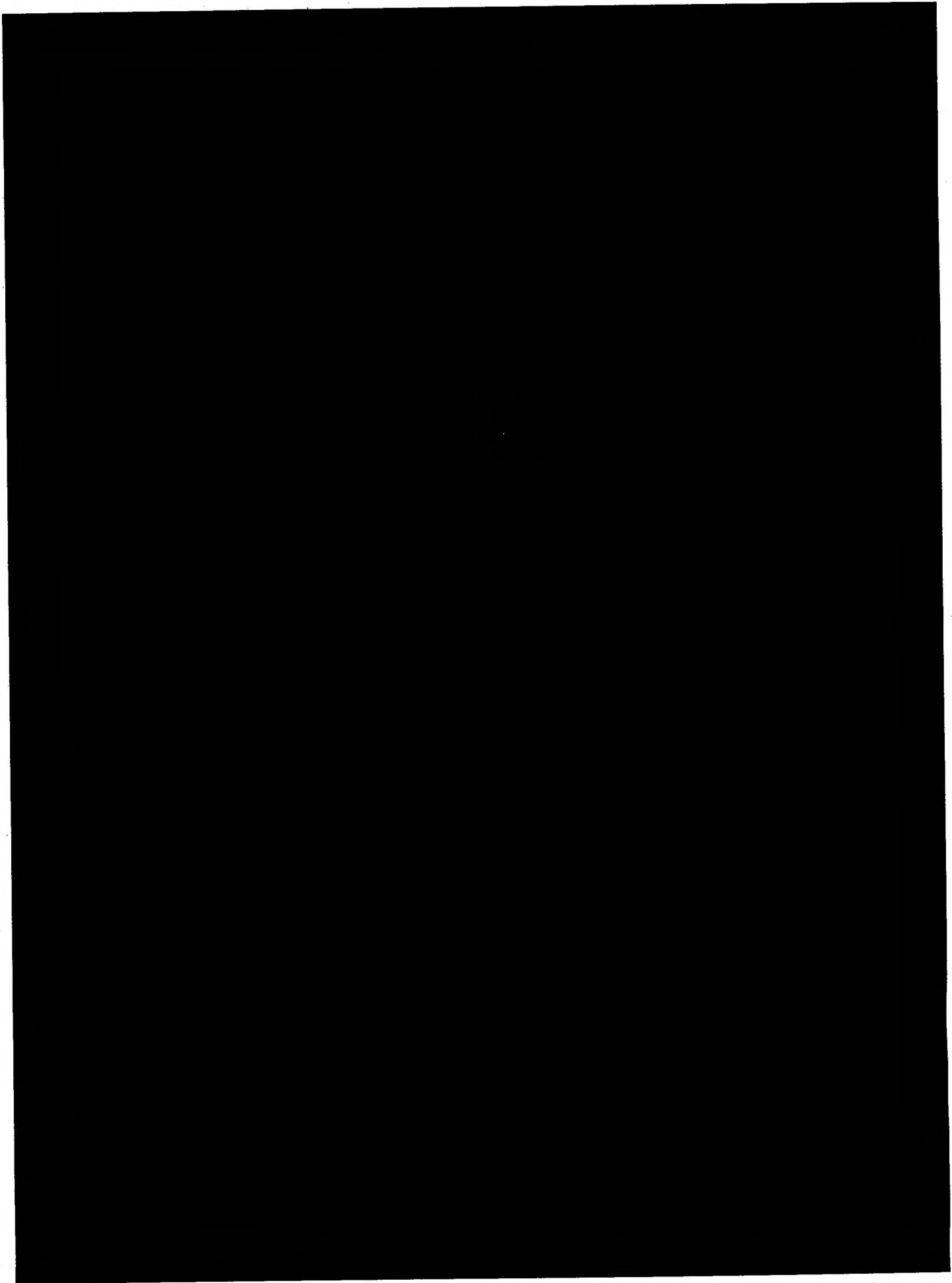

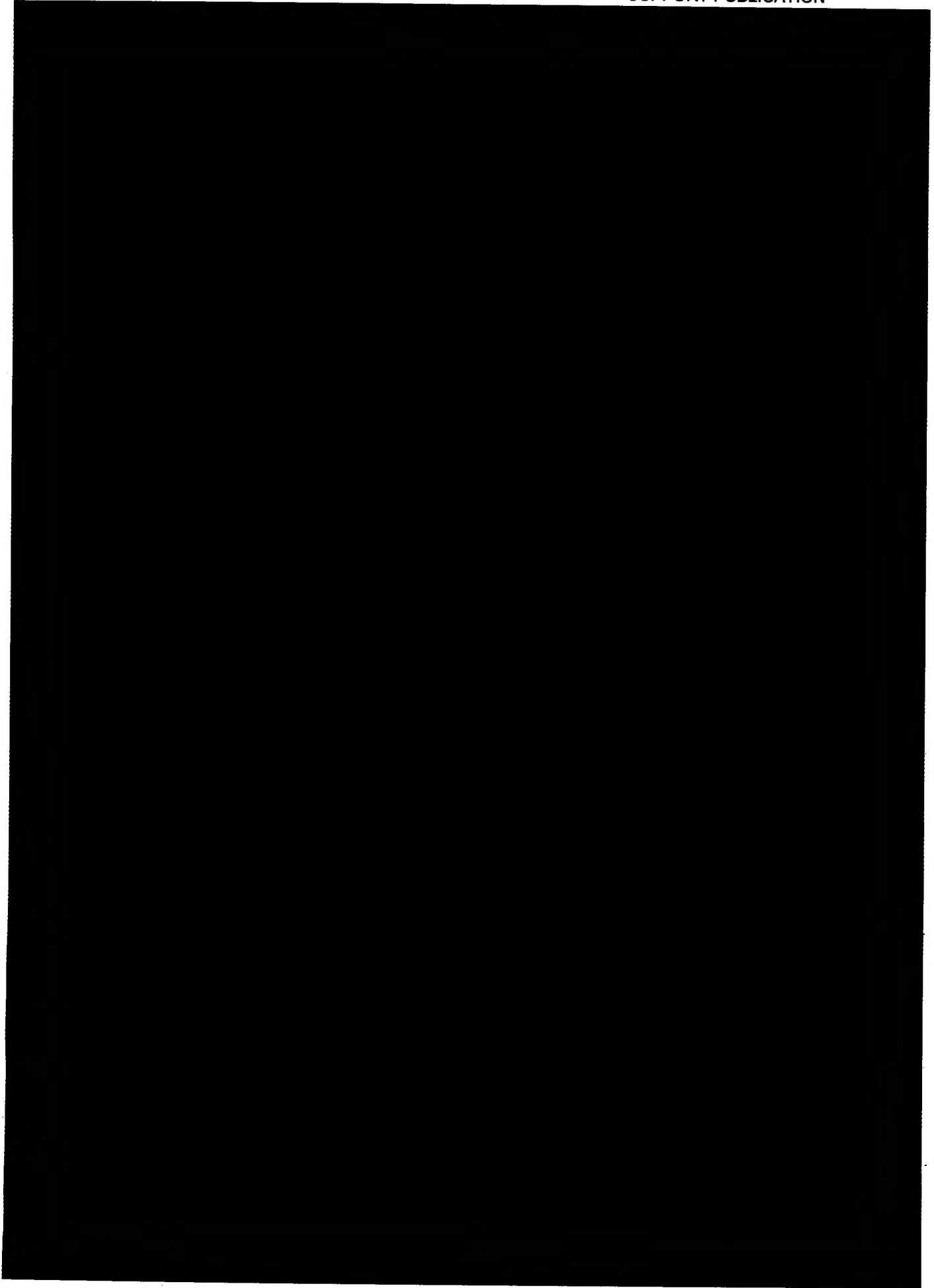

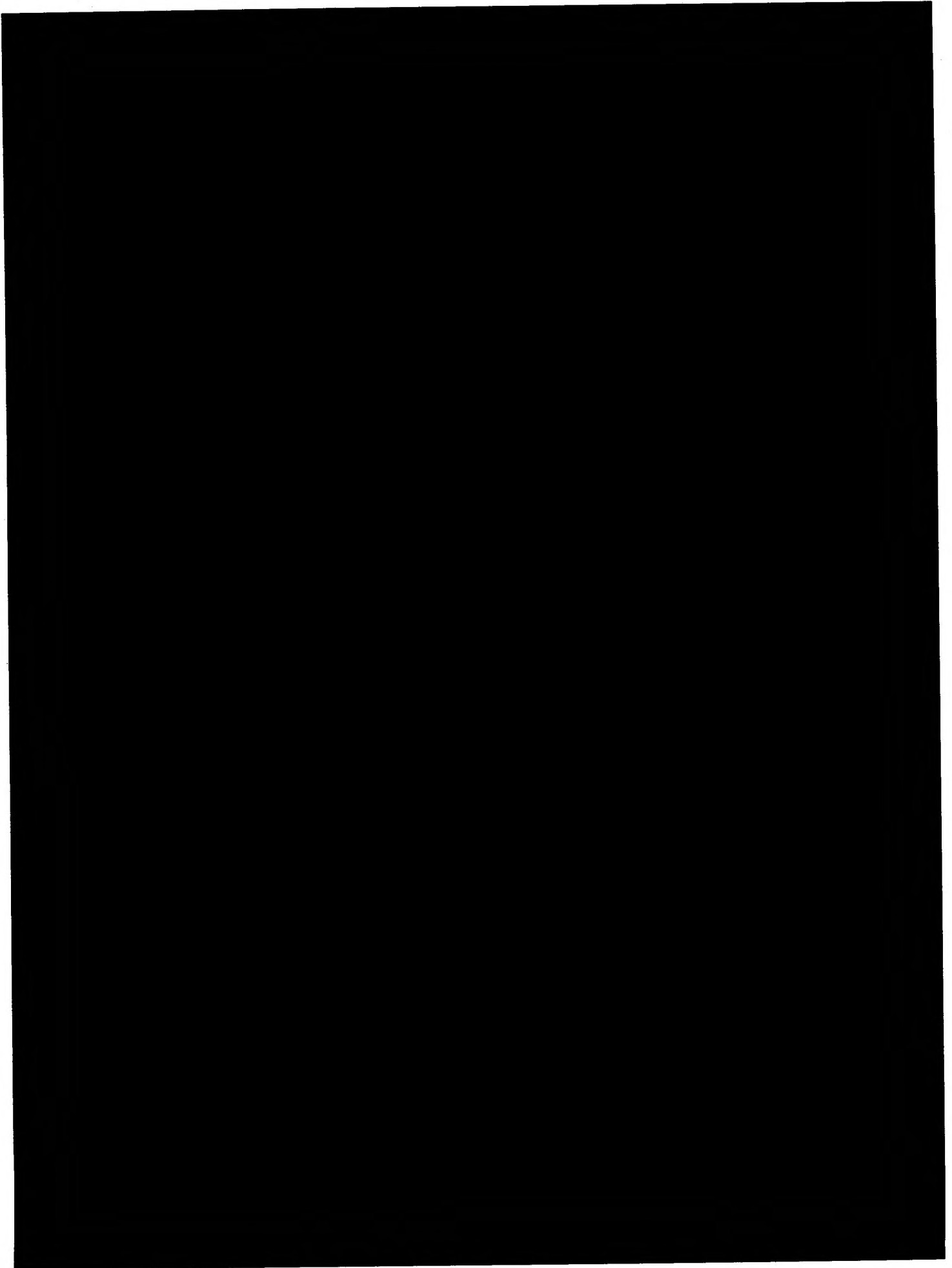

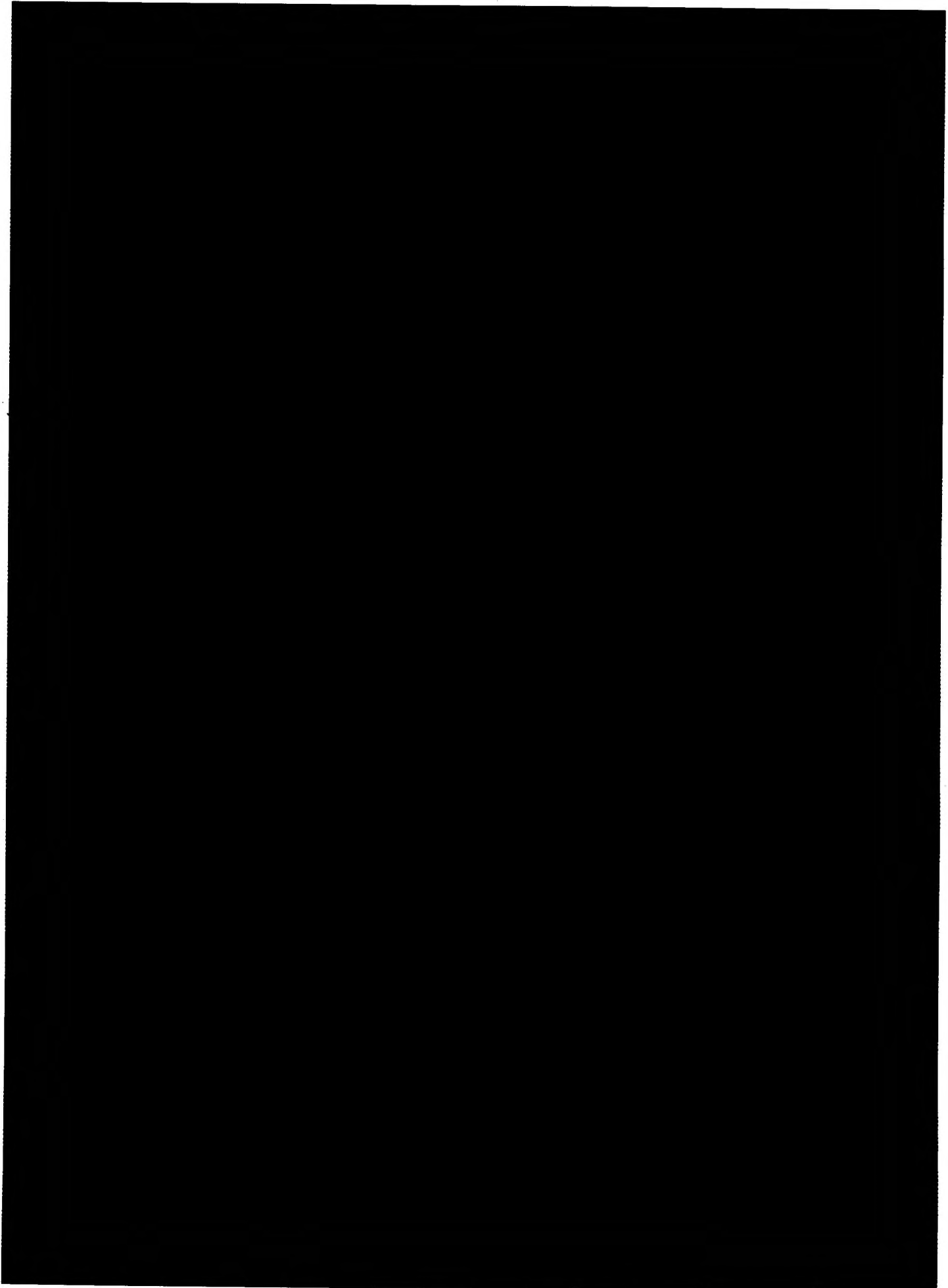

**TRUCK UTILITY LIGHT (TUL) HS
TRUCK UTILITY MEDIUM (TUM) HS
AND (TUM) AMBULANCE HS
INSTALLATION INSTRUCTION No 3**

Sponsor:

SUV IPT

Publications Agency:

CTS TD
DLO Andover
Project No: CSV041

AMENDMENT RECORD

Amdt No.	Incorporated By (Signature)	Date	Amdt No.	Incorporated By (Signature)	Date
1			4		
2			5		
3			6		

SUBJECT: Fitting of sand channel mounting brackets.

INTRODUCTION

CAUTION

VEHICLE RECORD BOOK. This instruction AESP 2320-D-128-411 must be retained with the vehicle record book.

1 This installation details the fitting of sand channel mounting brackets.

1.1 The vehicle can be converted back to its standard role when required by removing items fitted following this instruction and refitting original parts.

APPLICABILITY

2 This installation is to be fitted to WMIK vehicles only when approved by the Equipment Manager at DLO.

2.1 Unmodified stock, held at all levels of technical storage.

REASON FOR INSTALLATION

3 Code 2 - To improve operational performance

RELATED AND ASSOCIATED PUBLICATIONS

4 Refer to AESP: 2320-D-128-101 Purpose and Planning
2320-D-128-201 Operator Information
2320-D-128-711 Illustrated Parts Catalogue

IMPLEMENTATION PLAN

5

- 5.1 This modification is to be implemented by:
Units authorised to install the Weapons Mounted Installation Kit.
ARMY - Units authorised to carry out level 2 maintenance.

5.2 Associated modification instructions. Nil

Action required by

- 5.3 Units and establishments holding equipment.
- 5.3.1 Examine vehicle documents to see if modification is applicable.
- 5.3.2 Examine equipment or modification record plate to see if modification is embodied and where necessary Units with level 2 REME Support demand the stores required.
- 5.3.3 ARMY - On receipt of stores, request REME to modify equipment.
- 5.3.4 ARMY - Record the modification subject and AESP number in equipment documents.
- 5.4 Army units authorised to carry out levels 2,3 and 4 maintenance.
- 5.4.1 ARMY - When requested by users or during overhaul of equipments on charge without REME level 2 Support, obtain the items listed in Para 7 and carry out this modification.
- 5.4.2 Record completion details of modification against appropriate entry in equipment documents.
- 5.5 All recipients of this instruction. Add particulars to AESP 2320-D-128-411 Inst instr index.

MAN-HOUR CONTENT

- 6 Embodiment: 1 man-hour
- 6.1 Modification plate strike action: NA

EQUIPMENT AND STORES

7 The item numbers in this Para are used as references throughout Para 8.

7.1 Stores to be demanded

7.1.1 The following items to be demanded quoting this instruction as authority for demand.

Refer to item No	NSN/Part No	Manfrs No	Part Designation	Qty per veh
			Sand Channel Installation (WMIK) Comprising:	1
1		30053-015	Strap	(2)
2		30053-014	Front bracket	(1)
3			M8 x 20 lg hex hd screw ZP GRD 8.8 BS 3692	(2)
4			M8 plain washer ZP BS 4320	(4)
5			M8 nyloc nut ZP BS 4929	(4)
6		30053-018	Sand Channel	A/R
7		30053-013	Rear bracket	(1)
8			M8 x 20 lg soc csk hd screw GRD 12.9 ZP BS 4168	(2)
9			M6 plain washer ZP BS 4320	(12)
10			M6 nyloc nut ZP BS 4929	(6)
11			M6 x 20 lg hex hd screw ZP GRD 8.8 BS 3692	(6)
12		30053-019	Edging strip	(4)

Sequence of operations

8 Carry out the installation as follows:

NOTE

Brackets can be fitted to either side of the vehicle.

Refer to Fig 1

8.1 Park the vehicle on a flat level surface, apply the handbrake and remove the ignition keys.

8.2 Remove the second screw along from the rear of the vehicle securing the reinforcing plate to the top of the cargo rail.

8.3 Position the sand channel rear bracket (item 7) over the cargo rail and locate with the existing screw through hole nearest front of vehicle as shown.

8.4 Drill two 6.5mm dia holes through the body side using the rear channel bracket as a guide.

Refer to Fig 2

8.5 Secure the rear bracket (item 7) using two M6 screws (item 11), nuts (item 10) and washers (item 9) to the side of the vehicle.

8.6 If fitted, remove the Radio mast mounting bracket and use the existing holes to mount the front bracket (item 2).

8.7 Secure the bracket to the side of the vehicle using four M6 screws (item 11), nuts (item 10) and washers (item 9) through the existing reinforcement plates.

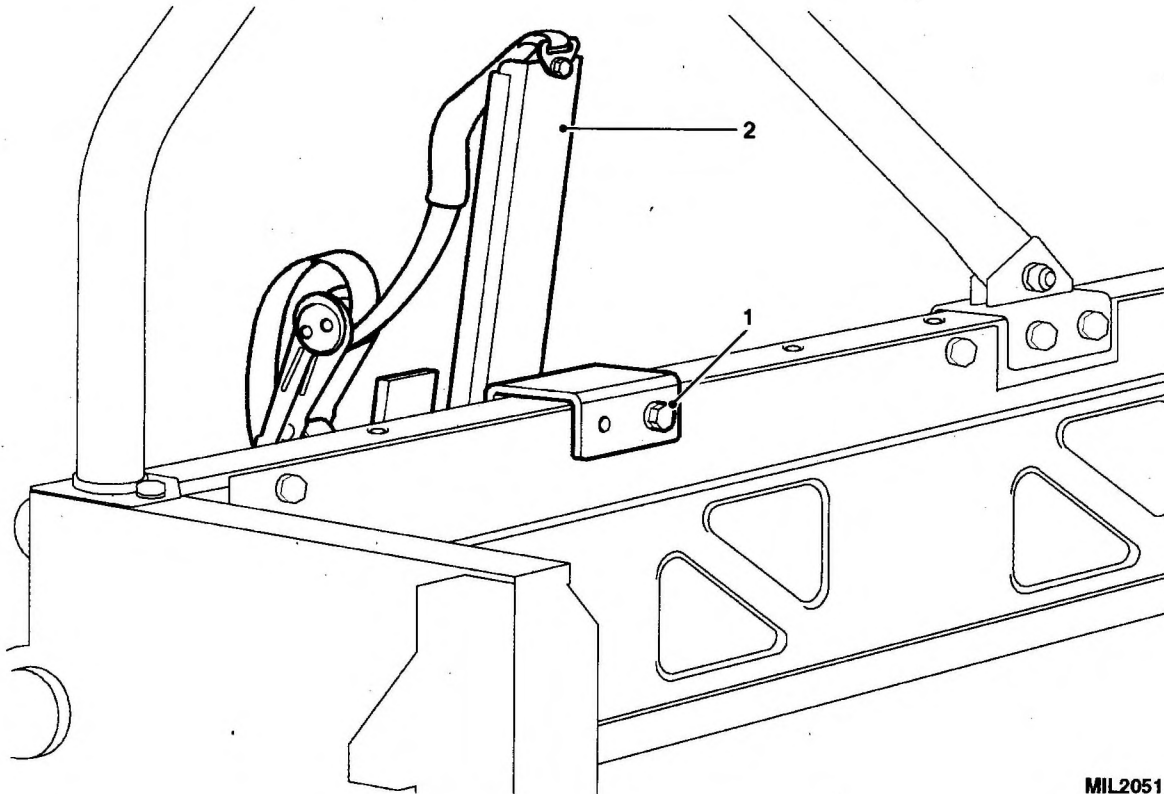

1 Rear Bracket

2 Existing Screw

Fig 1 Fitting the rear bracket

8.8 Attach the straps (item 1) to the front and rear brackets ensuring the shorter strap with the ratchet mechanism is fixed to the lower fixing using the M8 csk screws (item 8), M8 nuts (item 5) and M8 washers (item 4).

8.9 Attach the long part of the strap to the upper fixing using the M8 screws (item 3) M8 nuts (item 5) and M8 washers (item 4) and tighten.

8.10 Lift the sand channels one by one onto the brackets and secure by passing the upper strap through the corresponding holes in the top row of the sand channels and into the slot in the rear of the ratchet.

8.11 Operate the ratchets to take up the slack in the straps and secure the sand channels to the front and rear brackets.

Removal

9 To remove the sand channel brackets refer to this procedure in the reverse order.

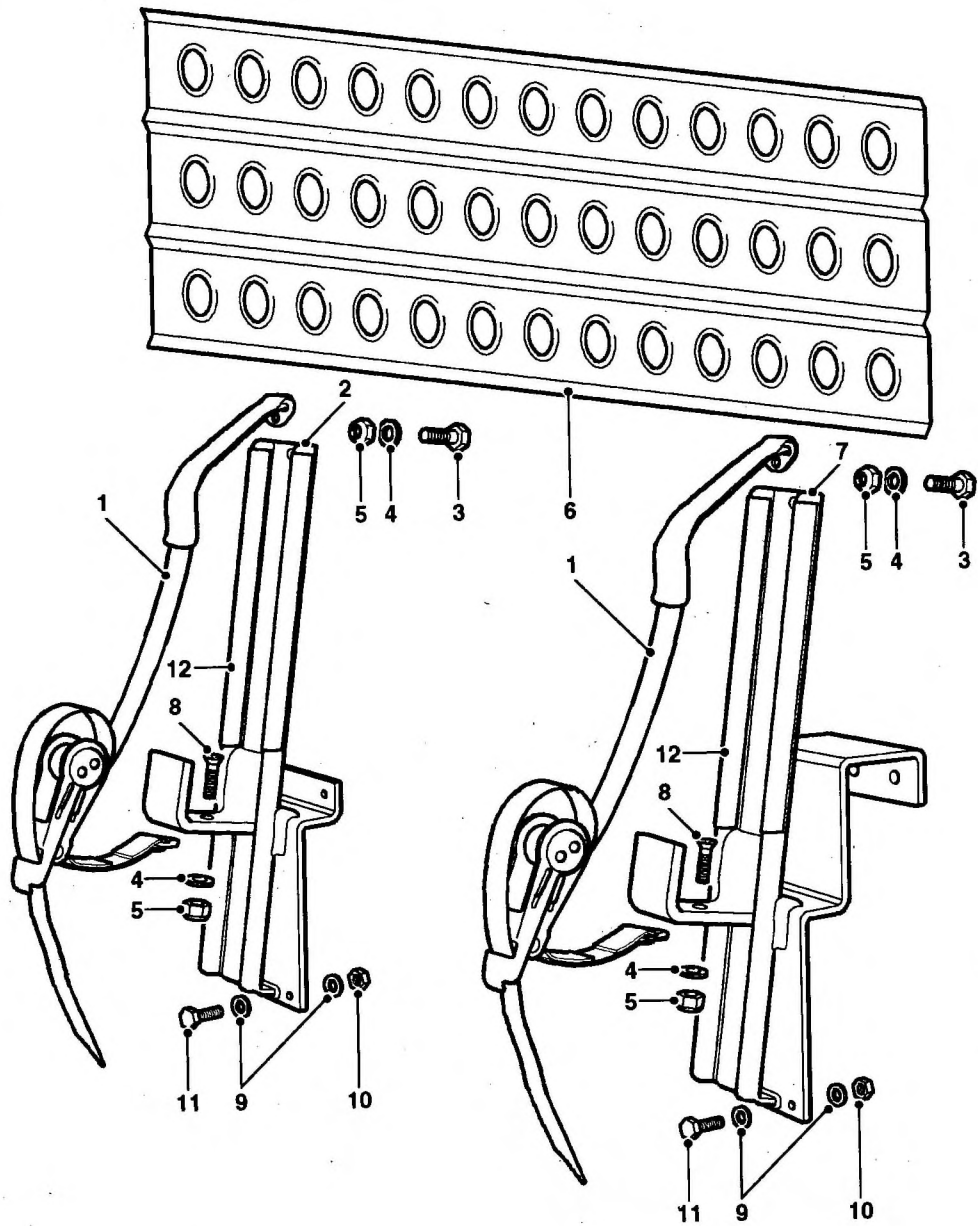

MIL2053

- 1 Strap
- 2 Front Bracket
- 3 M8 Screw
- 4 M8 Washer
- 5 M8 Nyloc Nut
- 6 Sand Channel

- 7 Rear Bracket
- 8 M8 Csk Screw
- 9 M6 Washers
- 10 M6 Nut
- 11 M6 Screw
- 12 Edging Strip

Fig 2 Fitting the mounting brackets

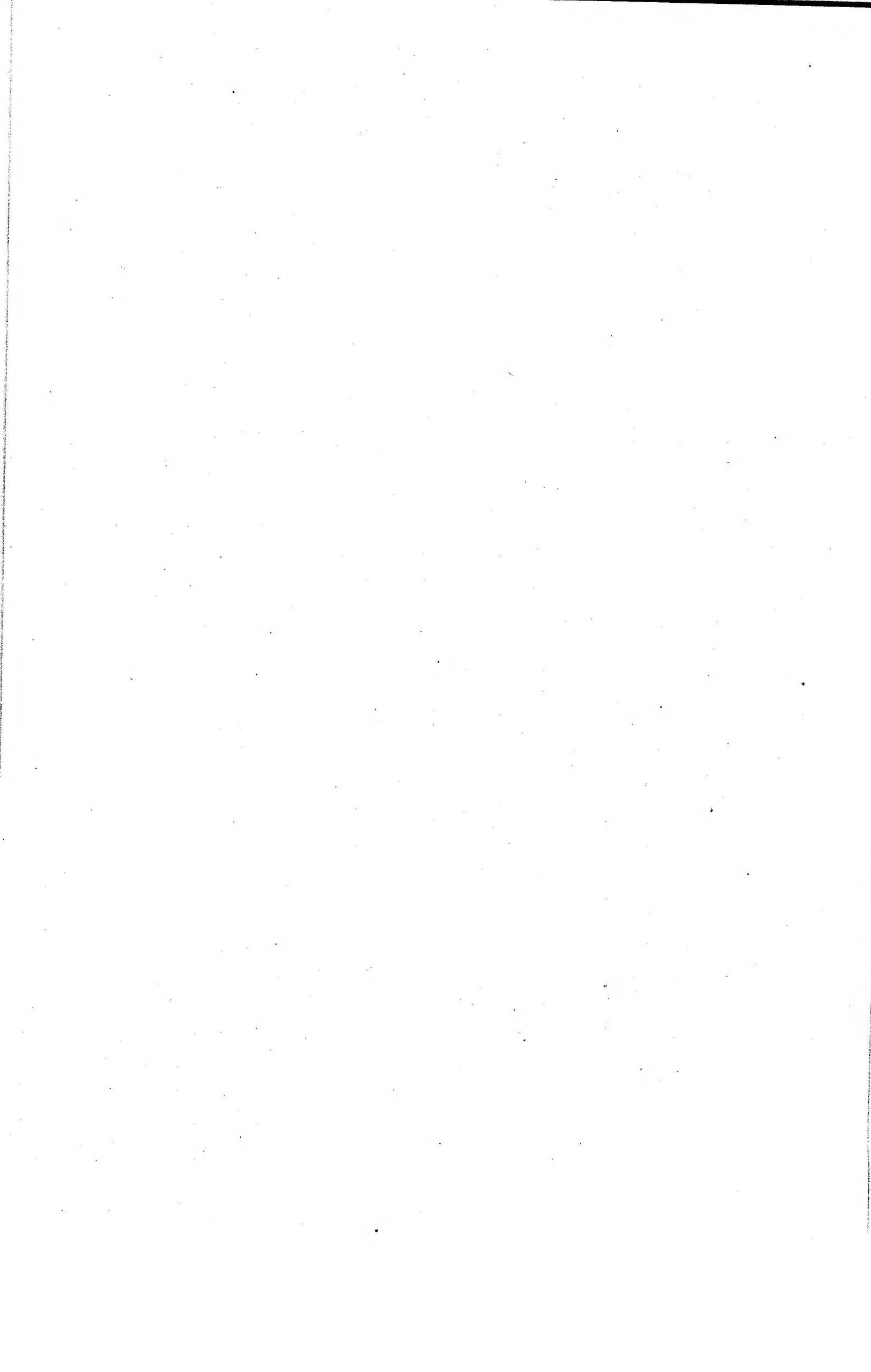

TRUCK UTILITY LIGHT (TUL) HS
TRUCK UTILITY MEDIUM (TUM) HS
AND (TUM) AMBULANCE HS
INSTALLATION INSTRUCTION No 4

Sponsor:

SUV IPT

Publications Agency:

CTS TD
DLO Andover
Project No: CSV041

AMENDMENT RECORD

Amdt No.	Incorporated By (Signature)	Date	Amdt No.	Incorporated By (Signature)	Date
1			4		
2			5		
3			6		

SUBJECT: Fitting of a front axle guard.

INTRODUCTION

CAUTION

VEHICLE RECORD BOOK. This instruction AESP 2320-D-128-411 must be retained with the vehicle record book.

1 This installation details the fitting of a front axle guard.

1.1 The vehicle can be converted back to its standard role when required by removing items fitted following this instruction and refitting original parts.

APPLICABILITY

2 This installation is to be fitted to WMIK vehicles only when approved by Equipment Manager at DLO.

2.1 Unmodified stock, held at all levels of technical storage.

REASON FOR INSTALLATION

3 Code 2 - To improve operational performance

RELATED AND ASSOCIATED PUBLICATIONS

4 Refer to AESP: 2320-D-128-101 Purpose and Planning
2320-D-128-201 Operator Information
2320-D-128-711 Illustrated Parts Catalogue

IMPLEMENTATION PLAN

5

5.1 This modification is to be implemented by:

Units authorised to install the Weapons Mounted Installation Kit.

ARMY - Units authorised to carry out level 2 maintenance.

5.2 Associated modification instructions. Nil

Action required by

5.3 Units and establishments holding equipment.

5.3.1 Examine vehicle documents to see if modification is applicable.

5.3.2 Examine equipment or modification record plate to see if modification is embodied and where necessary units with level 2 REME Support demand the stores required.

5.3.3 ARMY - On receipt of stores, request REME to modify equipment.

5.3.4 ARMY - Record the modification subject and AESP number in equipment documents.

5.4 Army units authorised to carry out levels 2,3 and 4 maintenance.

5.4.1 ARMY - When requested by users or during overhaul of equipments on charge without REME level 2 Support, obtain the items listed in Para 7 and carry out this modification.

5.4.2 Record completion details of modification against appropriate entry in equipment documents.

5.5 All recipients of this instruction. Add particulars to AESP 2320-D-128-411 Inst instr index.

MAN-HOUR CONTENT

6 Embodiment: 1 man-hour

6.1 Modification plate strike action: NA

EQUIPMENT AND STORES

7 The item numbers in this Para are used as references throughout Para 8.

7.1 Stores to be demanded

7.1.1 The following items are to be demanded quoting this instruction as authority for demand.

item No	NSN/Part No	Manftrs Part No	Designation	Qty per veh
		30053 - 021	Front axle guard Comprising:	1
1		30053 - 022	Hanger RH	(1)
2		30053 - 023	Hanger LH	(1)
3		30053 - 024	Guard main plate	(1)
4			Socket button hd screw M12 x 25 lg ZP GRD 12.9 BS 4168	(8)
5			Nyloc nut M12 ZP BS 4929	(8)

Sequence of operations

8 Carry out the installation as follows:

Refer to Fig 1

8.1 Park the vehicle on a suitable ramp, apply the handbrake and remove the ignition keys. Raise the ramp.

8.2 From underneath the vehicle remove the track rod protection bracket (1) mounted on the bottom of the differential pinion housing and return part to stores.

8.3 Remove the skid brackets (2) from the axle and return parts to stores.

8.4 Remove the anti-roll bar bolts (3) securing the roll bar to the ball joint assembly. Raise the roll bar (4) to allow access.

8.5 Remove the nuts on all the radius arm mounting bolts (5) and then individually remove and refit the bolts so that they face inwards towards the centre of the axle.

NOTE

Turn each bolt individually so as not to lose radius arm position and allow each bolt to protrude approximately 6-8 mm.

8.6 Install axle guard hanger (item 1) (9) on right side of axle assembly by hooking the rear of the hanger over the track rod and swing forward over and around the anti-roll bar bracket welded to the axle. Ensure front lugs face towards the centre of the axle.

8.7 Repeat for left hand side (item 2) and hook both brackets onto radius arm mounting bolts (6). Tap all bolts home.

8.8 Refit all radius arm mounting bolt nuts and tighten to 190Nm (140 lbf ft).

8.9 Pull down and re-attach anti-roll bar (7) to ball joint assembly and tighten bolts (8) to 68Nm (50 lbf ft).

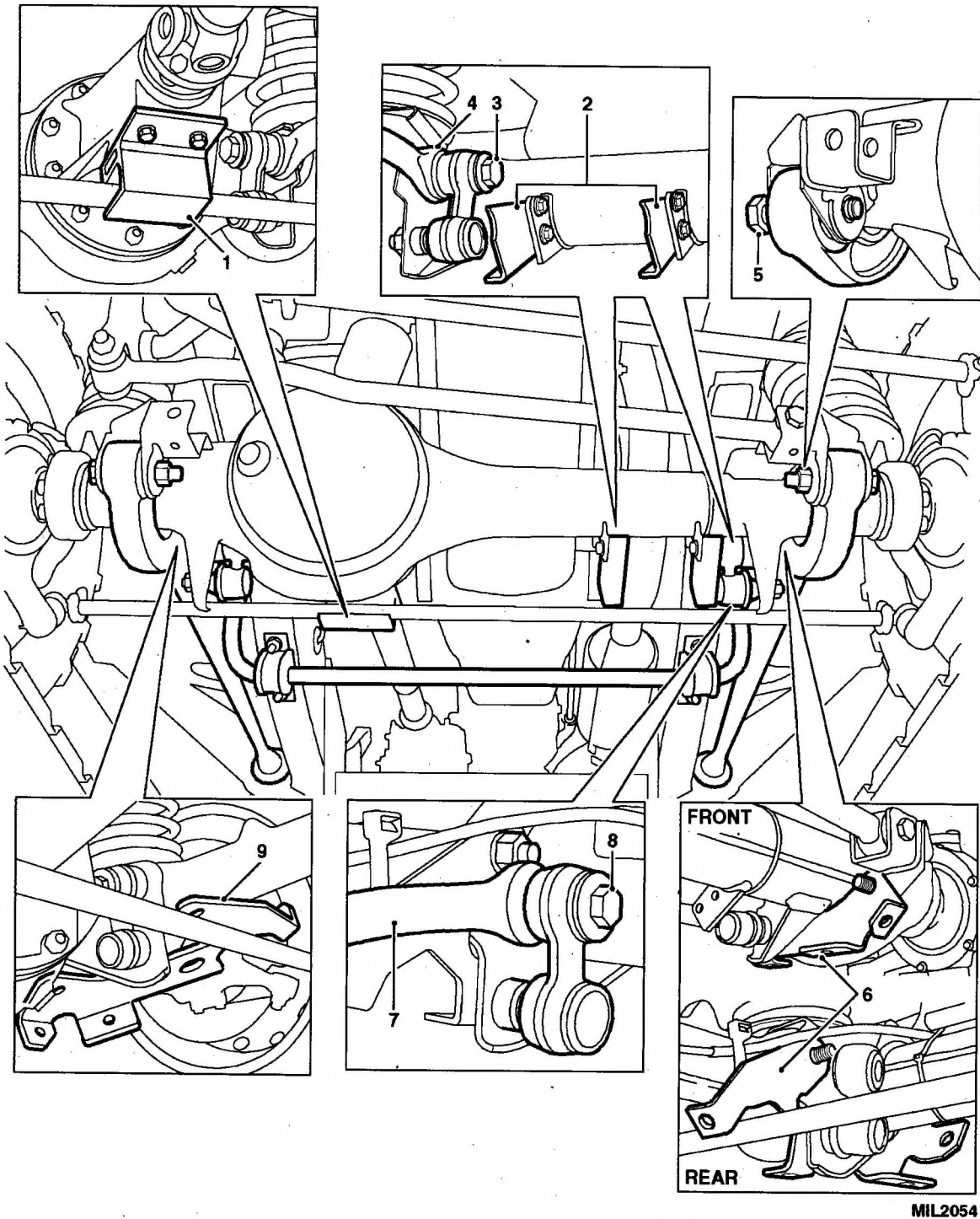

MIL2054

Fig 1 Fitting the front axle guard

Refer to Fig 2.

8.10 Attach axle guard main plate (item 3) by first inserting left hand front socket button set screw (item 4) on leading edge of axle guard main plate and loosely tighten nyloc nut (item 5). Insert socket button head screw into right hand corner of axle guard main plate trailing edge and loosely tighten nyloc nut.

8.11 Insert all remaining socket button set screws (8 in total) and tighten.

8.12 Lower ramp and remove vehicle.

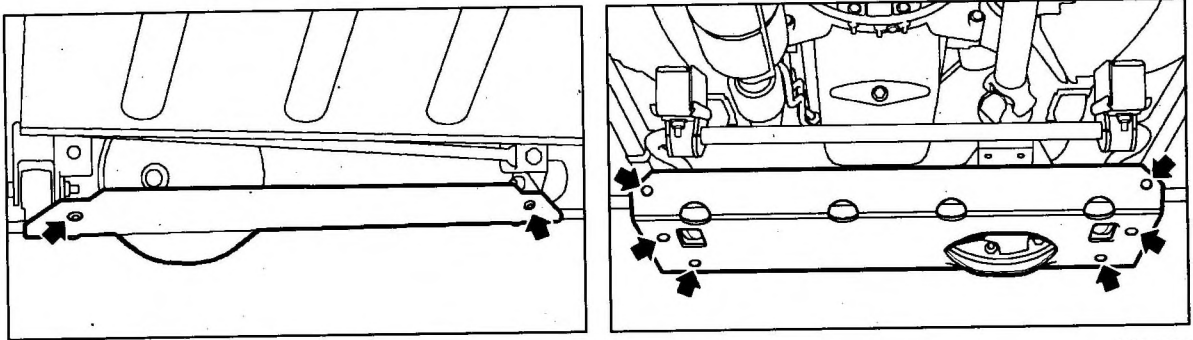

MIL2055

Fig 2 Securing the front axle guard

Removal

- 9 To remove the front axle guard refer to this procedure in the reverse order.

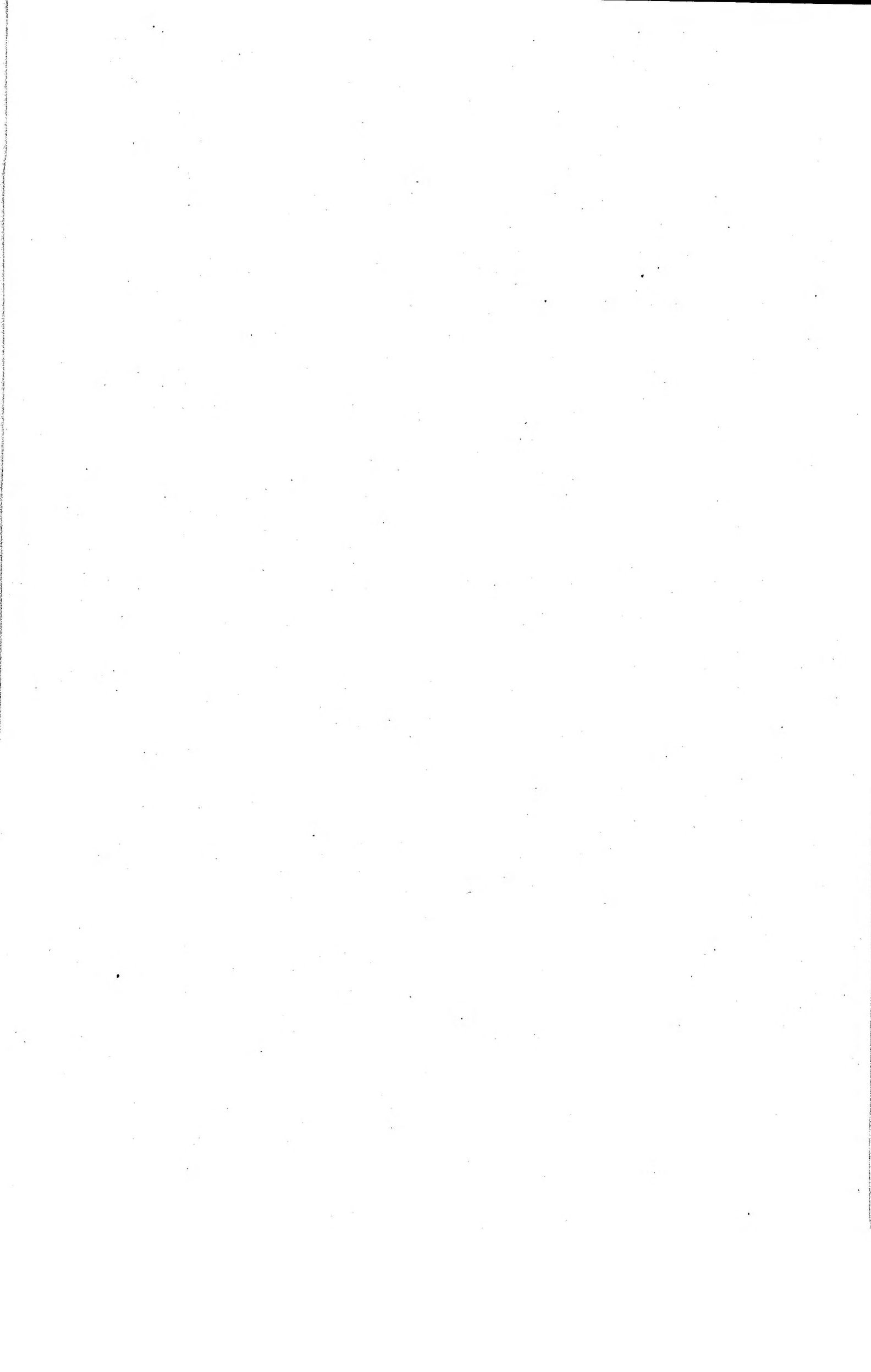

**TRUCK UTILITY LIGHT (TUL) HS
TRUCK UTILITY MEDIUM (TUM) HS
AND (TUM) AMBULANCE HS
INSTALLATION INSTRUCTION No 5**

Sponsor:

SUV IPT

Publications Agency:

CTS TD
DLO Andover
Project No.: CSV041

AMENDMENT RECORD

Amdt No.	Incorporated By (Signature)	Date	Amdt No.	Incorporated By (Signature)	Date
1			4		
2			5		
3			6		

SUBJECT: Fitting of GPMG barrel clamps.

INTRODUCTION

CAUTION

VEHICLE RECORD BOOK. This instruction AESP 2320-D-128-411 must be retained with the vehicle record book.

1 This installation details the fitting of GPMG barrel clamps.

1.1 The vehicle can be converted back to its standard role when required by removing items fitted following this instruction and refitting original parts.

APPLICABILITY

2 This installation is to be fitted to WMIK vehicles only when approved by Equipment Manager at DLO.

2.1 Unmodified stock, held at all levels of technical storage.

REASON FOR INSTALLATION

3 Code 2 - To improve operational performance

RELATED AND ASSOCIATED PUBLICATIONS

4 Refer to AESP: 2320-D-128-101 Purpose and Planning
2320-D-128-201 Operator Information
2320-D-128-711 Illustrated Parts Catalogue

IMPLEMENTATION PLAN

5

5.1 This modification is to be implemented by:

Units authorised to install the Weapons Mounted Installation Kit.

ARMY - Units authorised to carry out level 2 maintenance.

5.2 Associated modification instructions. Nil

Action required by

5.3 Units and establishments holding equipment.

5.3.1 Examine vehicle documents to see if modification is applicable.

5.3.2 Examine equipment or modification record plate to see if modification is embodied and where necessary units with level 2 REME Support demand the stores required.

5.3.3 ARMY - On receipt of stores, request REME to modify equipment.

5.3.4 ARMY - Record the modification subject and AESP number in equipment documents.

5.4 Army units authorised to carry out levels 2,3 and 4 maintenance.

5.4.1 ARMY - When requested by users or during overhaul of equipments on charge without REME level 2 Support, obtain the items listed in Para 7 and carry out this modification.

5.4.2 Record completion details of modification against appropriate entry in equipment documents.

5.5 All recipients of this instruction. Add particulars to AESP 2320-D-128-411 Inst instr index.

MAN-HOUR CONTENT

6 Embodiment: 1 man-hour

6.1 Modification plate strike action: NA

EQUIPMENT AND STORES

7 The item numbers in this Para are used as references throughout Para 8.

7.1 Stores to be demanded

7.1.1 The following items are to be demanded quoting this instruction as authority for demand.

item No	NSN/Part no	Manuftrs Part No	Designation	Qty per veh
			GPMG Barrel clamps Comprising:	1
1		30053-003	RH Barrel clamp - small	(1)
2		30053-002	LH Barrel clamp - large	(1)
3			M8 nyloc nut ZP BS 4929	(4)
4			M8 plain washer ZP BS 4320	(4)
5			M8x20 lg soc csk hd screw ZP GRD 12.9 BS 4168	(2)
6			M6 x 16 lg hex hd screw ZP BS 3692 GRD 8.8	(4)
7			M6 spring washer ZP BS 4464	(4)
8		30053-008	LH support bracket	(1)
9		30053-007	RH support bracket	(1)
10			M8 x 20 lg hex hd screw ZP BS 3692 GRD 8.8	(2)

Sequence of operations

8 Carry out the installation as follows:

Refer to Fig 1

8.1 Park the vehicle on a suitable ramp, apply the handbrake and remove the ignition keys. Raise the ramp.

8.2 Remove 0.5 HMG barrel clamps if fitted and return to stores.

LH support bracket

8.3 Remove existing bolt from wire cutter LH pivot.

8.4 Offer LH support bracket (item 8) to pivot mounting and secure with existing bolt ensuring the rear of the support bracket is in contact with the underside of the hamper top assembly.

8.5 Ensure bracket is positioned in line and drill an 8,5mm dia hole through hamper top assembly using the LH support bracket as a guide.

8.6 Paint edge of hole using chassis black paint to prevent corrosion.

8.7 Secure rear of support bracket to hamper top frame assembly using two M8 csk screws (item 5), nyloc nuts (item 3) and washers (item 4) and tighten all fixings.

8.8 Fit barrel large clamp assembly (item 2) to support bracket and secure using two M6 screws (item 6) and washers (item 7) through underside of support bracket.

8.9 Check operation of barrel clamp.

RH support bracket

8.10 Offer RH support bracket (item 9) to mounting plate on hamper top frame assembly and secure with two M8 screws (item 10), nyloc nuts (item 3) and washers (item 4) and tighten.

8.11 Fit small barrel clamp assembly (item 1) to bracket and secure using two M6 screws (item 6) and washers (item 7) through underside of support bracket. Position clamp so that the dimension between the inside faces of the clamps is 550mm.

8.12 Check operation of barrel clamp.

Removal

9 To remove the barrel clamps reverse this procedure.

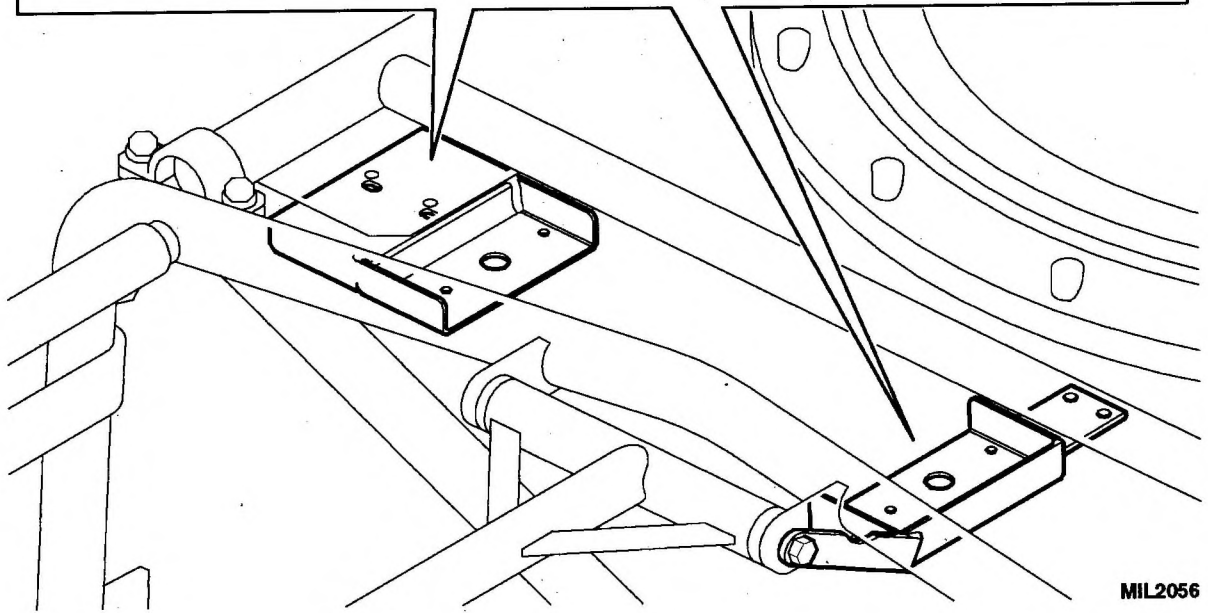
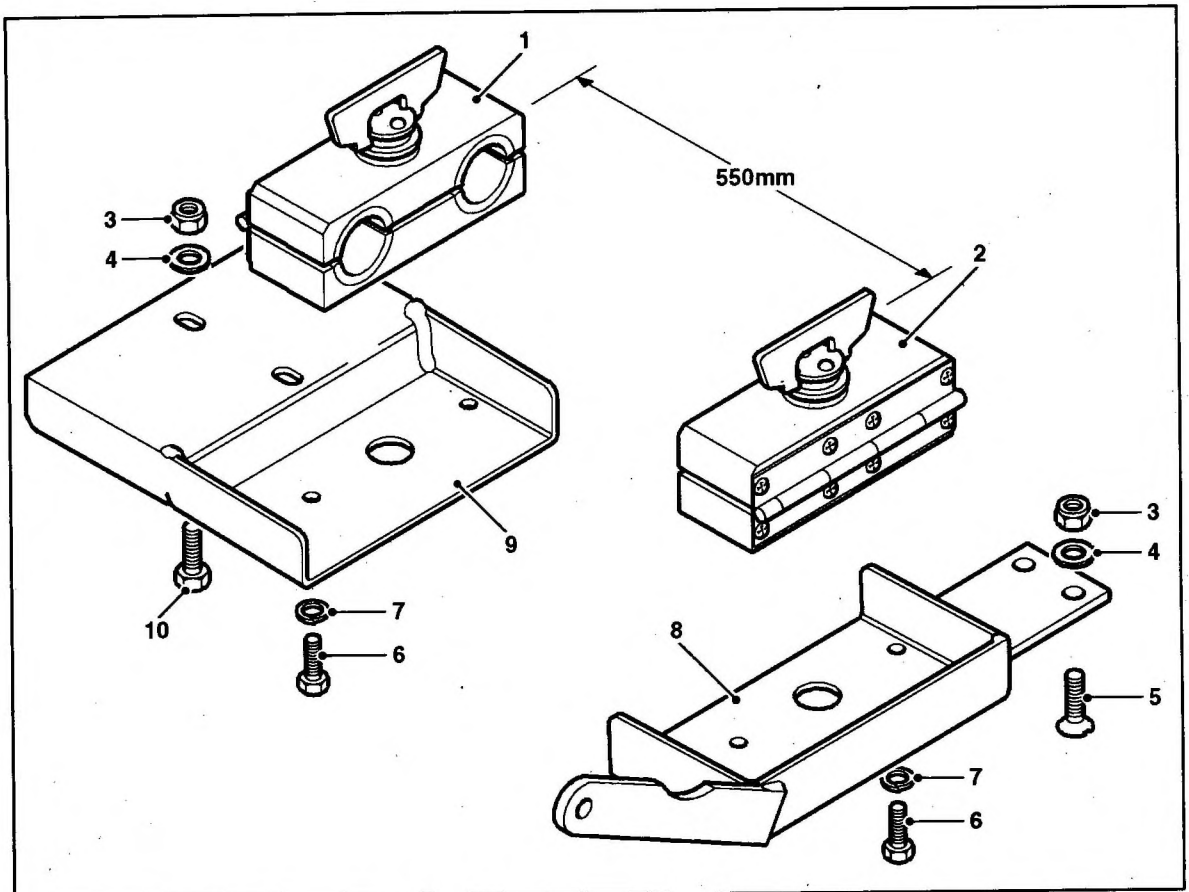

MIL2056

- | | | | |
|---|-----------------|----|--------------------|
| 1 | RH barrel clamp | 6 | M6 Screw |
| 2 | LH barrel clamp | 7 | M6 Washer |
| 3 | M8 Nyloc nut | 8 | LH support bracket |
| 4 | M8 Washer | 9 | RH support bracket |
| 5 | M8 Screw | 10 | M8 screw |

Fig 1 Fitting the GPMG barrel clamps

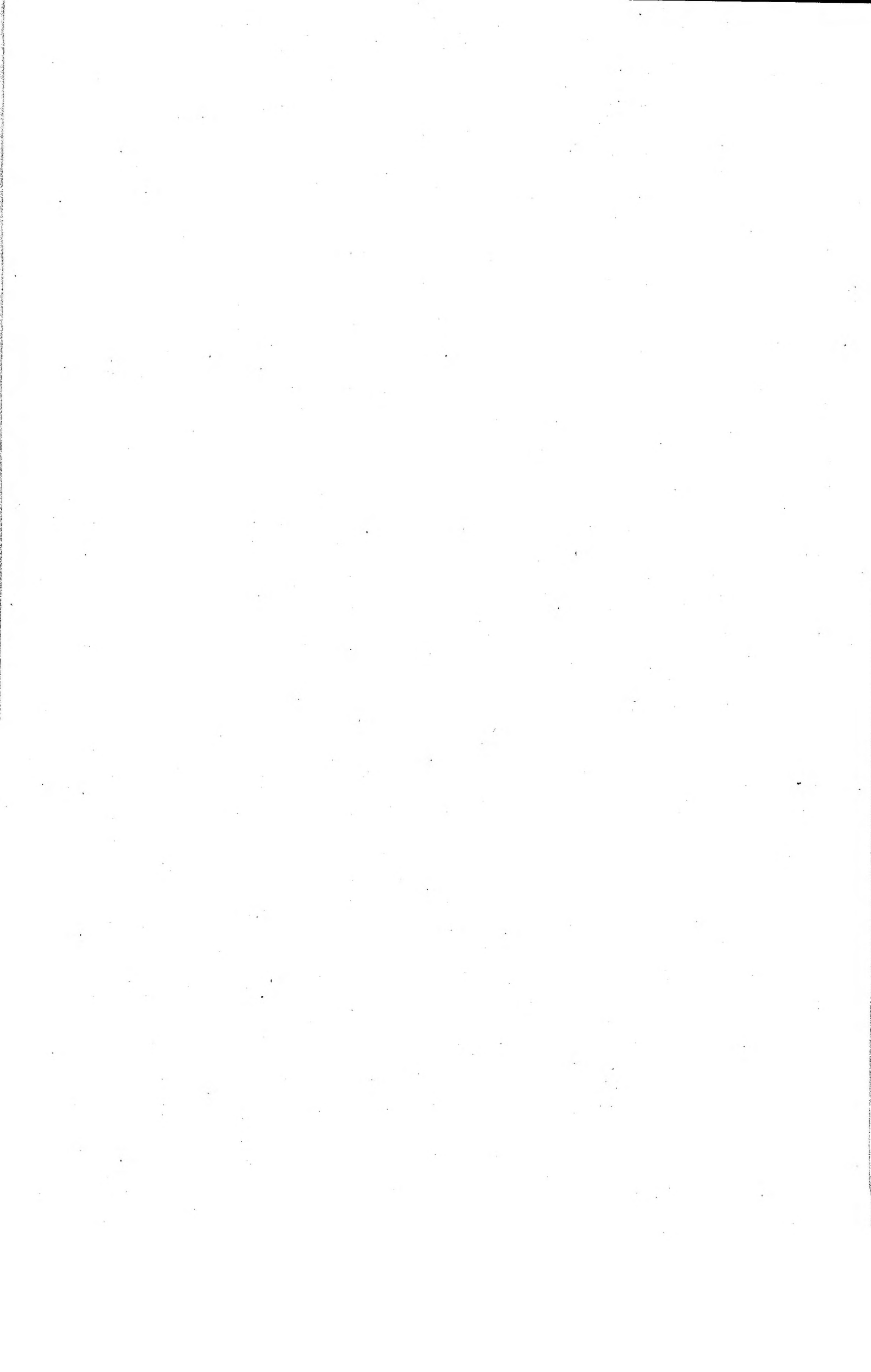

**TRUCK UTILITY LIGHT (TUL) HS
TRUCK UTILITY MEDIUM (TUM) HS
AND (TUM) AMBULANCE HS
INSTALLATION INSTRUCTION No 6**

Sponsor:
SUV IPT

Publications Agency:
CTS TD
DLO Andover
Project No: CSV041

AMENDMENT RECORD

Amdt No.	Incorporated By (Signature)	Date	Amdt No.	Incorporated By (Signature)	Date
1			4		
2			5		
3			6		

SUBJECT: Fitting of an additional Spare Wheel Carrier.

INTRODUCTION

CAUTION

VEHICLE RECORD BOOK. This instruction AESP 2320-D-128-411 must be retained with the vehicle record book.

- 1 This installation details the fitting of an additional Spare wheel Carrier.

1.1 The vehicle can be converted back to its standard role when required by removing items fitted following this instruction and refitting original parts.

APPLICABILITY

- 2 This installation is to be fitted to WMIK vehicles only when approved by Equipment Manager at DLO.

2.1 Unmodified stock, held at all levels of technical storage.

REASON FOR INSTALLATION

- 3 Code 2 - To improve operational performance

RELATED AND ASSOCIATED PUBLICATIONS

- 4 Refer to AESP: 2320-D-128-101 Purpose and Planning
2320-D-128-201 Operator Information
2320-D-128-711 Illustrated Parts Catalogue

IMPLEMENTATION PLAN

5

- 5.1 This modification is to be implemented by:
- Units authorised to install the Weapons Mounted Installation Kit.
- ARMY - Units authorised to carry out level 2 maintenance.

5.2 Associated modification instructions. Nil

Action required by

- 5.3 Units and establishments holding equipment.
- 5.3.1 Examine vehicle documents to see if modification is applicable.
- 5.3.2 Examine equipment or modification record plate to see if modification is embodied and where necessary units with level 2 REME Support demand the stores required.
- 5.3.3 ARMY - On receipt of stores, request REME to modify equipment.
- 5.3.4 ARMY - Record the modification subject and AESP number in equipment documents.
- 5.4 Army units authorised to carry out levels 2,3 and 4 maintenance.
- 5.4.1 ARMY - When requested by users or during overhaul of equipments on charge without REME level 2 Support, obtain the items listed in Para 7 and carry out this modification.
- 5.4.2 Record completion details of modification against appropriate entry in equipment documents.
- 5.5 All recipients of this instruction. Add particulars to AESP 2320-D-128-411 Inst instr index.

MAN-HOUR CONTENT

- 6 Embodiment: 30 mins
- 6.1 Modification plate strike action: NA

EQUIPMENT AND STORES

7 The item numbers in this Para are used as references throughout Para 8.

7.1 Stores to be demanded

7.1.1 The following items are to be demanded quoting this instruction as authority for demand.

item No	NSN/Part No	Manfrs No	Part Designation	Qty per veh
			Spare Wheel Carrier Comprising:	1
1		ANR5820	Carrier	(1)
2	2540-99-665-3740	5300-144	Spacer	(4)
3			M8 x 50 Hex hd bolt ZP GRD 8.8 BS 3692	(4)
4			M8 nut Binx type ZP	(4)
5			M8 plain washer ZP BS 4320	(8)

Sequence of operations

8 Carry out the installation as follows:

Refer to Fig 1

- 8.1 Park the vehicle on a level surface, apply the handbrake and remove the ignition keys..
- 8.2 Remove the Canopy (if fitted).
- 8.3 Locate the additional spare wheel carrier (item 1) on the roll cage mounting brackets and loosely secure with the fixings (items 3, 4 and 5). Ensure the spacers (item 2) are located in between the mounting brackets and the carrier.
- 8.4 Tighten the fixings.
- 8.5 Mount spare wheel onto carrier and secure. (Refer to Cat 201 Chap 4-1).

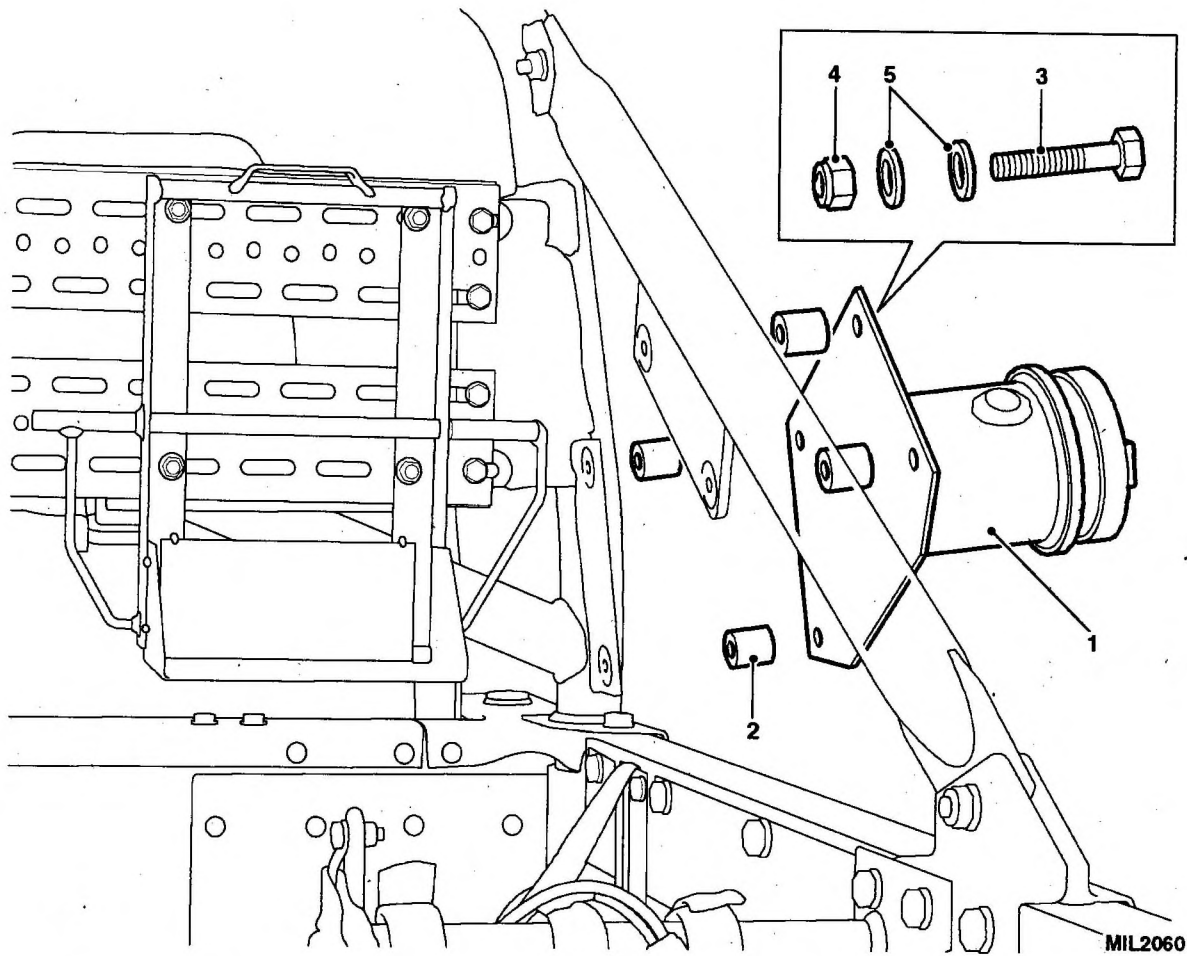

- | | | | |
|---|---------------------|---|--------|
| 1 | Spare Wheel Carrier | 4 | Nut |
| 2 | Spacer | 5 | Washer |
| 3 | Bolt | | |

Fig 1 Fitting the additional spare wheel carrier

Removal

9 To remove the additional spare wheel carrier, reverse this procedure.

8.12 Lower ramp and remove vehicle.

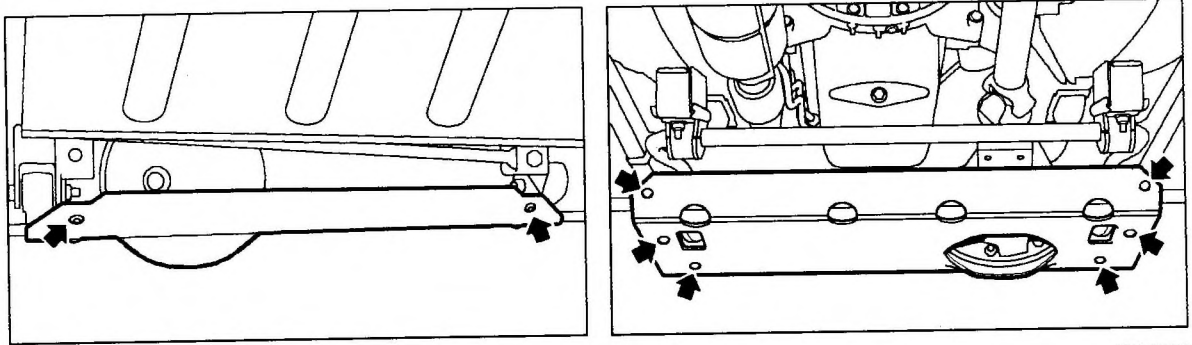

MIL2055

Fig 2 Securing the front axle guard

Removal

- 9 To remove the front axle guard refer to this procedure in the reverse order.

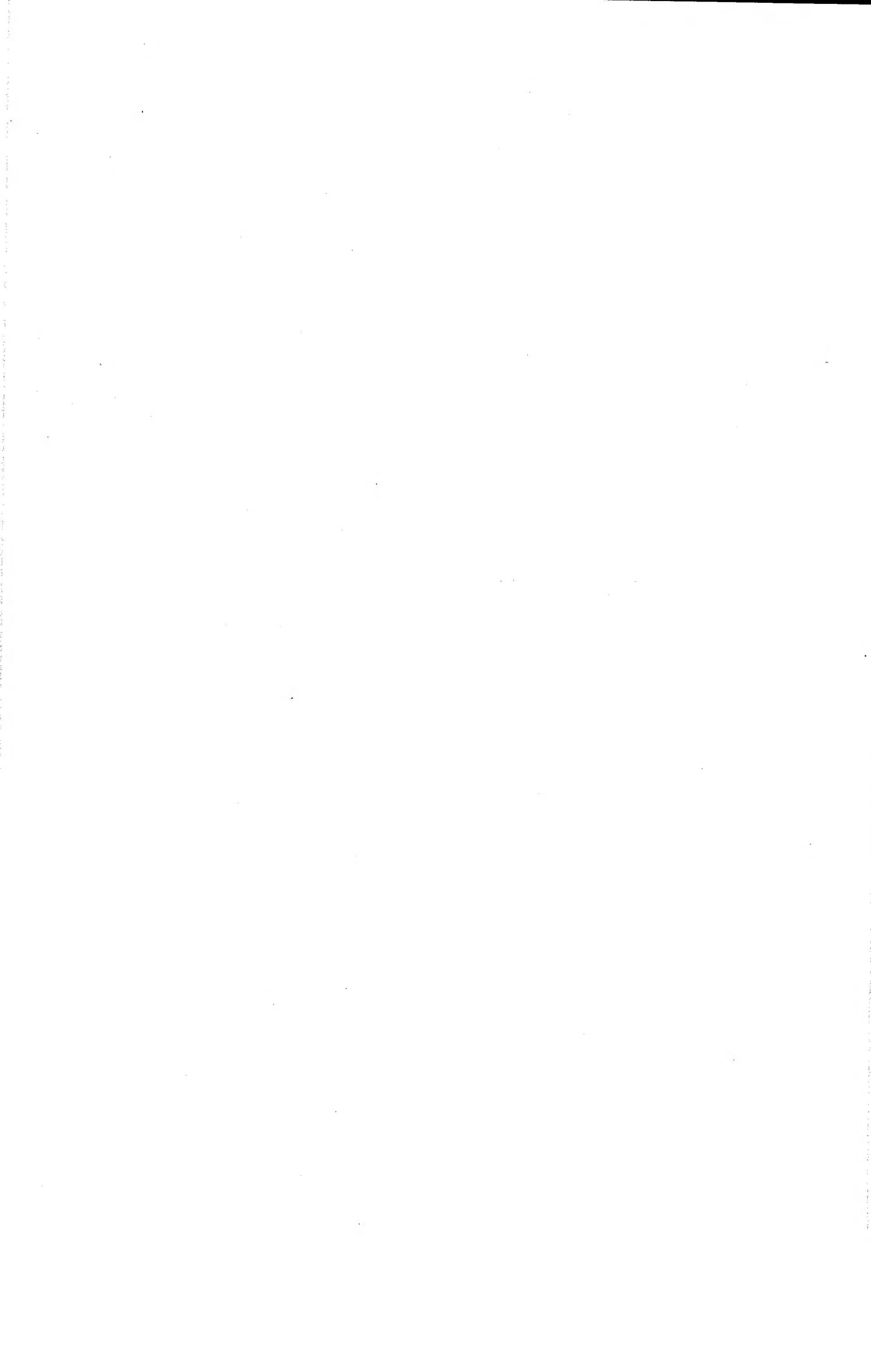

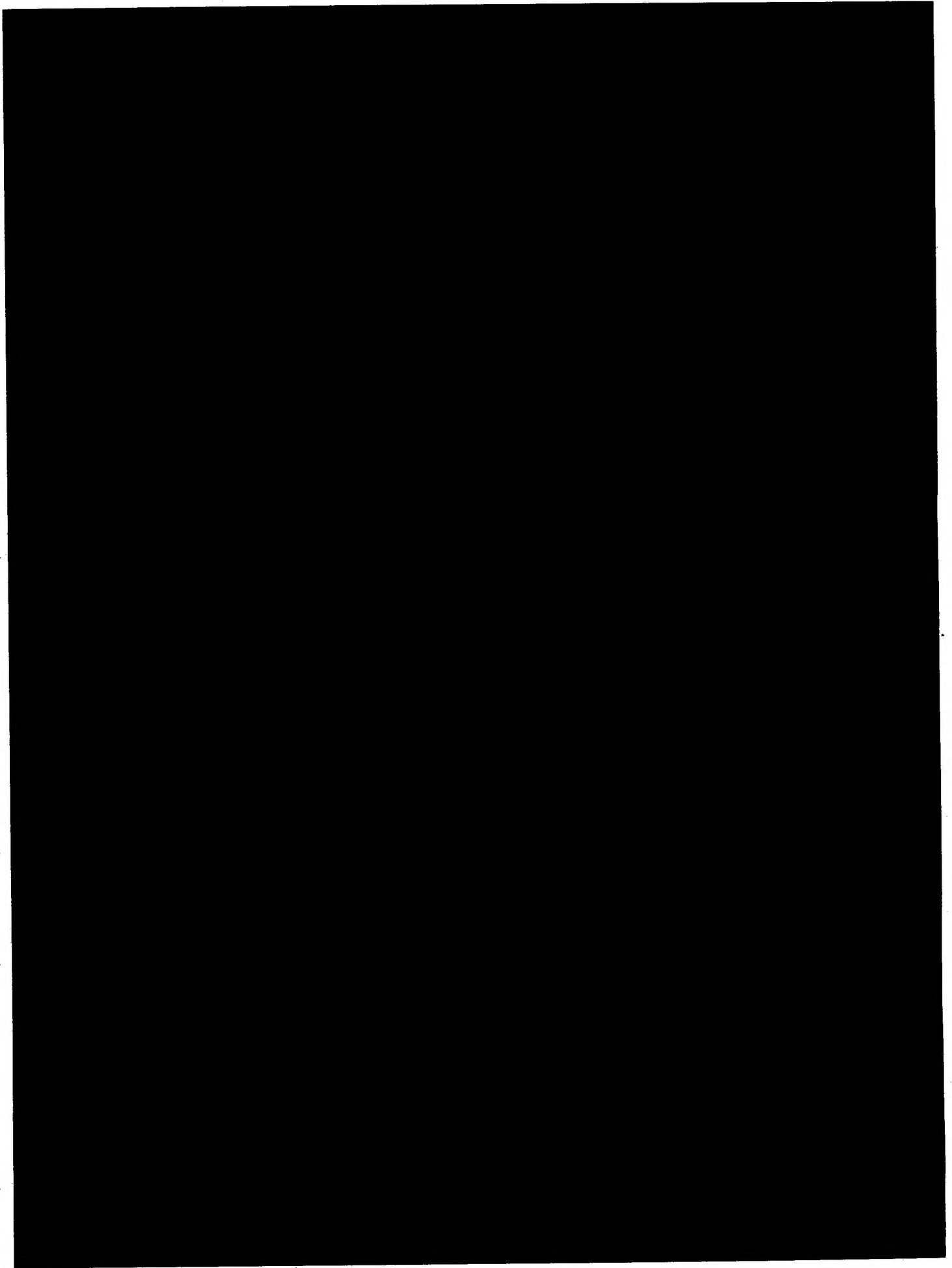

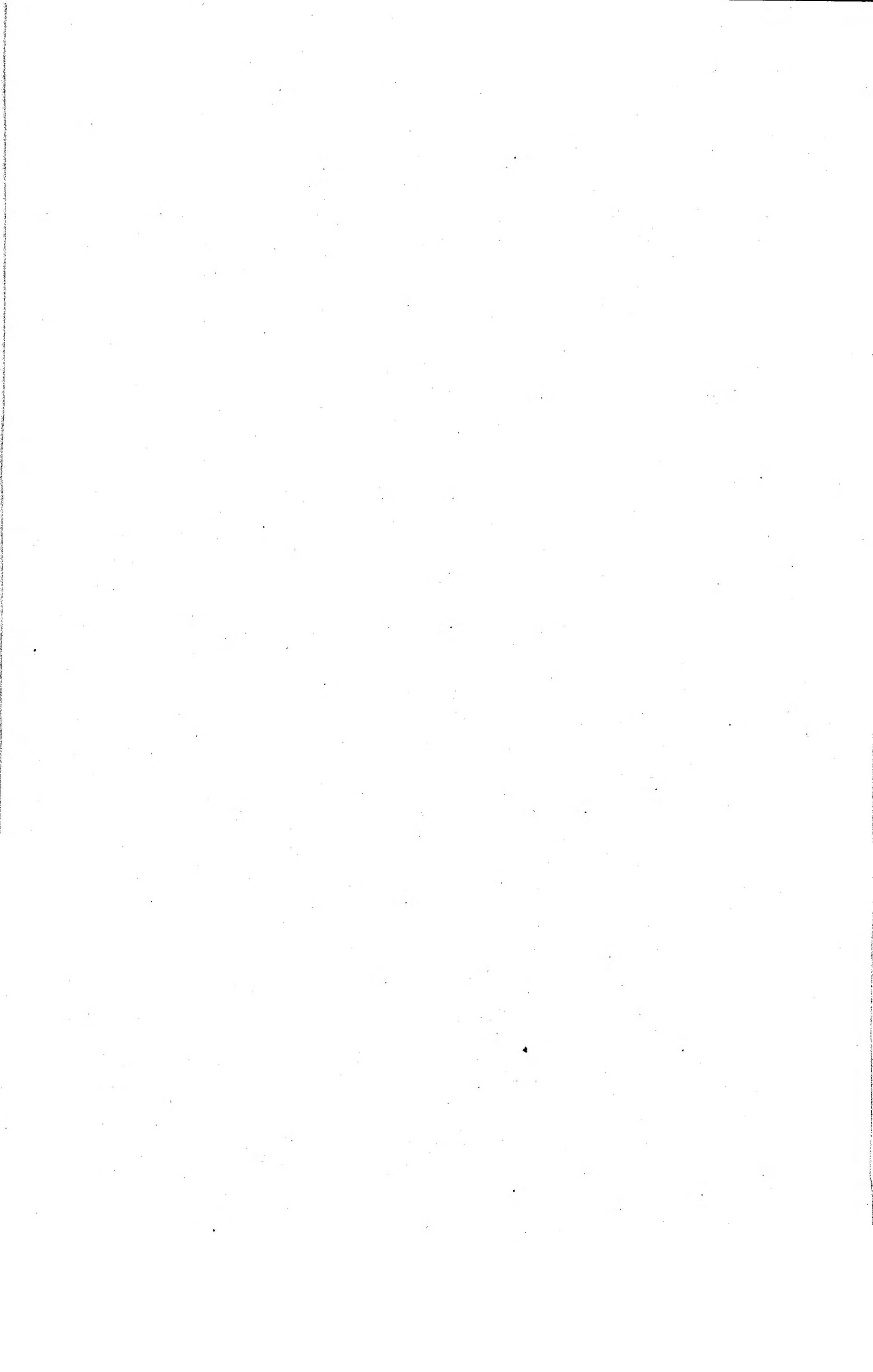

TRUCK UTILITY LIGHT (TUL)
TRUCK UTILITY MEDIUM (TUM)
DEFENDER
AND RWMIK

INSTALLATION INSTRUCTION No 8

Sponsor: SUV IPT
Project No.:
File Ref:

Publication Authority: TES TI Andover

AMENDMENT RECORD

Amdt No.	Incorporated By (Signature)	Date	Amdt No.	Incorporated By (Signature)	Date
1			4		
2			5		
3			6		

SUBJECT: Installation of the 12/24 volt sockets on the Truck Utility Light (TUL), Truck Utility Medium (TUM), Defender and RWMIK.

INTRODUCTION

1 This instruction details the installation of 12/24 volt sockets to the Truck Utility Light (TUL), Truck Utility Medium (TUM), Defender and RWMIK.

1.1 The introduction of additional electrical equipment to the vehicle has raised the need for external power supplies. This kit provides one 12v (DIN type) and one 24v (cigar lighter type) power socket located on the centre instrument panel. The 12v socket being powered through a suppressed DC/DC converter is switched to prevent battery drain. This should be switched 'off' when not in use. The kit is supplied with 2 universal plugs (with adaptors) allowing use of both sockets. Both supplies are fitted with in line fuse protection.

1.2 Limitations on use of equipment. Nil

APPLICABILITY

2 Truck Utility Light (TUL), Truck Utility Medium (TUM), Defender and WMIK as and when nominated by the appropriate authority.

2.1 Unmodified stock, held at all levels of technical storage.

REASON FOR INSTALLATION

3 To equip Truck Utility Light (TUL), Truck Utility Medium (TUM), Defender and WMIK with 12/24 volt sockets. The equipment to be installed is as follows:

- 3.1 Instrument panel with socket outlets and on/off switch for 12 volt supply.
- 3.2 DC/DC converter with harness and clamp.

RELATED AND ASSOCIATED PUBLICATIONS

- 4 Refer to AESP:
 - 2320-D-128-201 Operating Information
 - 2320-D-128-302 Technical Descriptions
 - 2320-D-128-522 Repair Instructions
 - 2320-D-128-523 Repair Instructions
 - 2320-D-128-601 Maintenance Schedules
 - 2320-D-128-811 Modification instructions

IMPLEMENTATION PLAN

5

- 5.1 This modification is to be implemented by:
 - Units authorised to install the 12/24V sockets.
 - ARMY - Units authorised to carry out level 3 maintenance.
- 5.2 Associated modification instructions. Nil

Action required by

- 5.3 Units and establishments holding equipment.
 - 5.3.1 Examine vehicle documents to see if modification is applicable.
 - 5.3.2 Examine equipment or modification record plate to see if modification is embodied and where necessary Units with level 3 REME Support demand the stores required.
 - 5.3.3 ARMY - On receipt of stores, request REME to modify equipment.
 - 5.3.4 ARMY - Record the modification subject and AESP number in equipment documents.
- 5.4 Army units authorised to carry out levels 2,3 and 4 maintenance.
 - 5.4.1 ARMY - When requested by users or during overhaul of equipments on charge without REME level 3 Support, obtain the items listed in Para 7 and carry out this modification.
 - 5.4.2 Record completion details of modification against appropriate entry in equipment documents.
- 5.5 All recipients of this instruction. Add particulars to AESP 2320-D-128-411 Inst instr index.

ESTIMATED TIME REQUIRED

6 Embodiment: 1.5 man-hours

6.1 Modification plate strike action: NA

EQUIPMENT AND STORES

Stores

7 Normally, individual items are not issued separately but may be demanded to make good kit deficiencies. Such demands are to quote full part numbers and designations as shown in this installation instruction Para 8.1. A brief explanation of circumstances necessitating the demand is to be attached.

WARNING

HEALTH AND SAFETY. MATERIALS USED IN THE CONVERSION ARE REQUIRED TO MEET OBLIGATIONS INTRODUCED UNDER THE CONTROL OF SUBSTANCES HAZARDOUS TO HEALTH REGULATIONS 1994 (COSHH). SAFETY INFORMATION RELATING TO MATERIALS USED IS CONTAINED IN JSP (F) 395-CATALOGUE OF HAZARDOUS STORES.

7.1 Stores to be demanded.

7.1.1 The following modification items are to be demanded quoting this instruction as authority for demand.

Item No	NSN/Part No	Designation	Qty per veh
	7XD-5999-99-213-1219	12/24V socket outlets kit: comprising:	1
1		Instrument panel with socket outlets and on/off switch for 12 volt supply.	(1)
2	7XD-5935-99-995-5732	Panel DC socket outlets	(1)
3	7XD-6130-99-753-0108	DC/DC converter with wiring harness attached	(1)
4	7XD-5340-99-989-1249	Clamp DC/DC converter	(1)
5	7XD-5935-99-593-3110	Socket 24v (cigar lighter style)	(1)
6	7XD-5935-99-335-7363	Socket 12v (DIN style)	(1)
7	7XD-5920-99-993-5105	Fuse holder (in-line blade type)	(2)
8	7XD-5920-99-759-5251	Fuse 7.5 amp	(1)
9	7XD-5920-99-759-5252	Fuse 10 amp	(1)
		Rocker switch	(1)
10	7XD-5935-99-134-8277	Universal plug 16 amp	(2)

Sequence of operations**NOTES**

- (1) The main numbers of Para 7 are used as references throughout this instruction.
- (2) The installation kit fits both LH and RH drive vehicles.

DETAILED INSTRUCTIONS**WARNING**

HEALTH AND SAFETY. MATERIALS USED IN CONVERSION ARE REQUIRED TO MEET OBLIGATIONS INTRODUCED UNDER THE CONTROL OF SUBSTANCES HAZARDOUS TO HEALTH REGULATIONS 1994 (COSHH). SAFETY INFORMATION RELATING TO MATERIALS USED IS CONTAINED IN JSP (F) 395-CATALOGUE OF HAZARDOUS STORES.

CAUTION

If difficulties are encountered, the Unit (MTO) should be consulted.

PREPARATION

- 8 Carry out the following preliminary tasks.

WARNINGS

- (1) **FLAMMABLE SUBSTANCES. NO SMOKING OR NAKED FLAMES. LEAD ACID BATTERIES PRODUCE POTENTIALLY EXPLOSIVE GASES.**
- (2) **HEALTH AND SAFETY. BATTERIES CONTAIN CORROSIVE ACID ELECTROLYTE. WEAR PROTECTIVE GLOVES AND GOGGLES WHEN HANDLING BATTERIES.**
- (3) **HEALTH AND SAFETY. ENSURE APPROPRIATE CLOTHING AND GOGGLES ARE WORN WHEN DRILLING.**

Vehicle and radio batteries.

- 9 Disconnect the vehicle batteries (refer to Cat 522, Chap 13-1) and on Fitted For Radio (FFR) vehicles the radio batteries (refer to Chap 13-2).

INSTALLATION

- 10 Remove centre light switch panel to provide access.
- 11 Disconnect the wires from the inspection lamp sockets on the light switch panel. These wires will be connected to the new wiring harness later (see para 18).
- 12 Remove right hand side panel.
- 13 Remove centre instrument panel and ammeter (refer to 522, Chap 13-2).
- 14 Refit ammeter to new front panel with 12V socket and switch to right hand side.
- 15 Fit new panel in position (2) and loosely locate left hand side fixing screw and nut.
- 16 Position DC/DC converter (3) as shown so that cable end of unit is flush with the right hand edge of the cable entry hole at the rear of the dash panel and rubber pads are on underside.

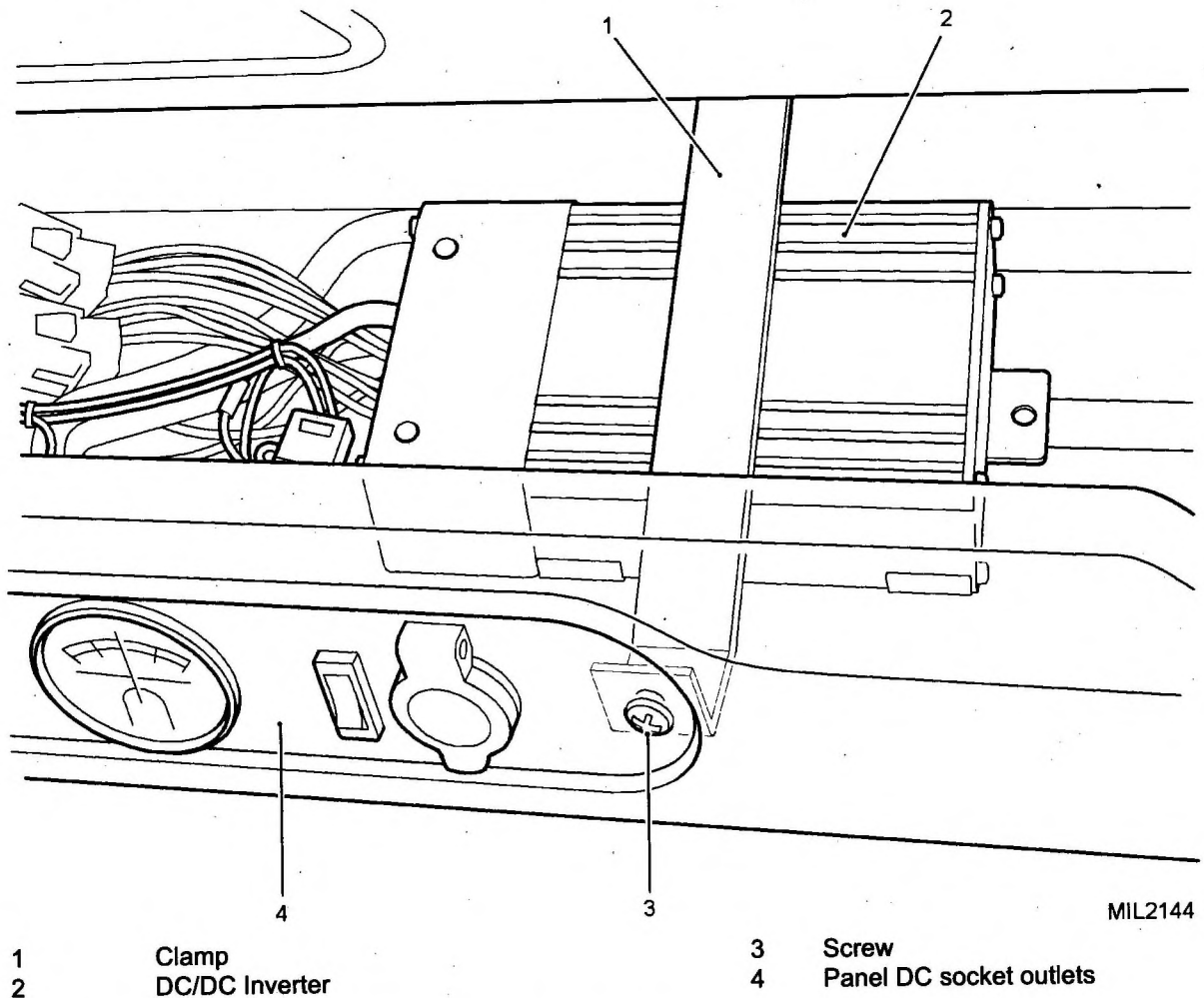

MIL2144

Fig 1 DC/DC converter installation

17 Fit clamp (4) by locating the un-drilled end under bend in rear panel of dash and inline with right hand instrument panel fixing screw (Fig 1 (3)), with the clamp pressed against the DC/DC converter fit the right hand side instrument panel screw ensuring it passes through the clamp, before tightening fixing screws ensure clamp is pressed firmly against DC/DC converter to secure it in place.

18 Connect harness to the wires removed from the inspection lamp sockets adhering to the colour code for correct connection ie. brown to brown and black to black. Ensure the wiring is neatly installed with inline fuses easily visible.

19 Refit side panel and light switch panel ensuring no wires are trapped.

20 Reconnect battery supply and check for output at each socket.

21 Two universal plugs are provided for user connection, these have a red removable adaptor that prevents connection to the wrong socket and has to be removed for connection to the 12V socket. These should be wired with the centre pin to positive.

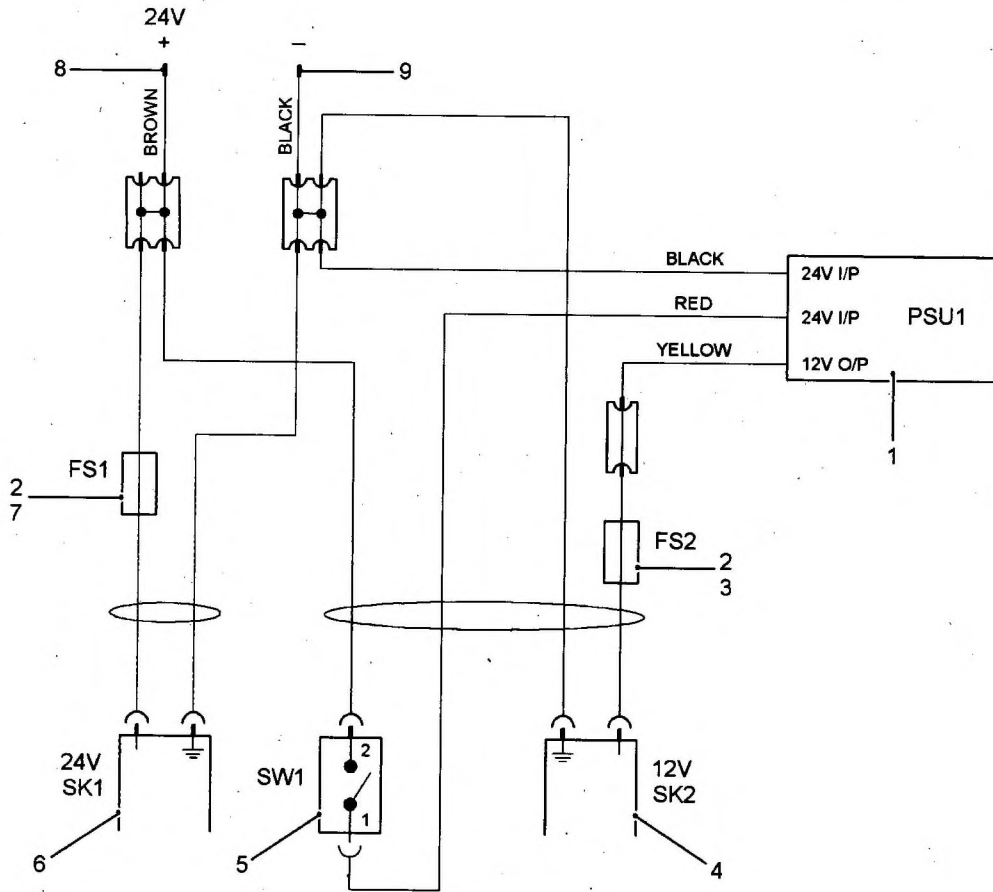

MIL2145

- | | | | |
|---|---------------------|---|------------------------|
| 1 | DC/DC Inverter | 6 | 24V socket |
| 2 | Fuse holder | 7 | Fuse 7.5 Amp |
| 3 | Fuse 10 Amp | 8 | Connector - Brown wire |
| 4 | 12V socket | 9 | Connector - Black wire |
| 5 | Switch - 12V socket | | |

Fig 2 Wiring Diagram MIL2145

Testing after embodiment

22 All circuitry to be tested to Def-Stan 61-5 part 3 for security of system.

EFFECT ON WEIGHT

23 Negligible.

PUBLICATION AMENDMENTS

NOTE

Necessary amendment will be issued separately.

COMMENT(S) ON AESP*

To: DCCS
BFPO 794

From:
.....
.....
.....

Sender's Reference	BIN Number	Date
AESP Title: TRUCK UTILITY LIGHT (TUL) HS TRUCK UTILITY MEDIUM (TUM) HS AND (TUM) AMBULANCE HS INSTALLATION INSTRUCTIONS AND INDEX		
Chapter(s)/Instruction	Page(s)/Paragraph(s)	
If you require more space, please use the reverse of this form or a separate piece of paper. Comment(s):		

Signed: Telephone No:
Name (Capitals): Rank/Grade: Date:
X
.....

FOR AESP* SPONSOR USE ONLY

To: From:
.....
.....
.....

Thank you for commenting on AESP
Your reference Dated

Action is being taken to:	Tick	Tick
Issue a revised/amended AESP		Under investigation
Incorporate comment(s) in future amendments		No action required
Remarks		

Signed: Telephone No:
Name (Capitals): Rank/Grade: Date:

* AESP or EMER
AESP Form 10 (Issue 5 dated Dec 01)

