



Ministry
of Defence

de&s

LLB(Hons)
DE&S Secretariat (Land Equipment)

DESSEC-PolSecLE-JSC-WPNS@mod.uk

Defence Equipment & Support
Maple 0a # 2043
MOD Abbey Wood
Bristol BS34 8JH



Via:

14th March 2019 Our Ref: FOI2019/00722

Dear [REDACTED],

Thank you for your email of 2nd January 2019 requesting the following information:

Could you please provide Merlin Report and / or details of vehicle history for my (description of vehicles.) I confirm that I am the registered keeper of these vehicles.

The details from the VIN plate are as follows:

Land Rover Defender 110 FFR 71-KJ-99

Land Rover Series 2A Lightweight 35-FG-12

Sankey Trailers

42-ET-74

52-AW-69

24-ET-58

27-EN-32

These following two I'm not sure of the reg as the plates are worn and hard to read the reg but I'm supplying the other information on them to hope you can find something on them.

Reg: 81-PK-17 ?

CES No: 33984

Cont No: WV9264

Chassis No: 586

Code No 2855 0790

NSN: 2330-99-806-7070

Defence Equipment & Support

Reg: 48-FL-17

CES No: 33984

Cont No: 10710 / 90710 (Either or)

Chassis No: 6_3 (What I can see on the plate)

Code No: 2855 0790

Also I would like to make a freedom of Information request for the following documents;

1. AESP 2300-A-050-0 13 B Vehicle Test, Inspection and Certification
2. AESP 0200-A-221-013 Painting of Service Equipment
3. AESP 2320-A-300-532 B Vehicle Cab Corrosion Inspection Standards
4. AESP 2300-A-310-201 B Vehicle Corrosion Prevention
5. AESP 2300-A-600 Waterproofing Regulations-Vehicles and Equipment
6. The user and services manual with a circuit diagram for the series 2A Landover lightweight
7. The user and services manual with a circuit diagram for the Landover 110 ffr

This was clarified on the 15th January 2019 as follows:

Could you please provide Merlin Report and / or details of vehicle history for my (description of vehicles.) I confirm that I am the registered keeper of these vehicles.

The details from the VIN plate are as follows:

Land Rover Defender 110 FFR 71-KJ-99

Land Rover Series 2A Lightweight 35-FG-12

Sankey Trailers

42-ET-74

52-AW-69

24-ET-58

27-EN-32

These following two I'm not sure of the reg as the plates are worn and hard to read the reg but I'm supplying the other information on them to hope you can find something on them.

Reg: 81-PK-17 ?

CES No: 33984

Cont No: WV9264

Chassis No: 586

Code No 2855 0790

NSN: 2330-99-806-7070

Reg: 48-FL-17

CES No: 33984

Cont No: 10710 / 90710 (Either or)

Chassis No: 6_3 (What I can see on the plate)

Code No: 2855 0790

Also I would like to make a freedom of Information request for the following documents;

1. AESP 0200-A-221-013 *Painting of Service Equipment*
2. AESP 2300-A-300-532 *B Vehicle Cab Corrosion Inspection Standards*
3. AESP 2300-A-310-201 *B Vehicle Corrosion Prevention*
4. AESP 2300-A-600 *Waterproofing Regulations-Vehicles and Equipment*
5. *The user and services manual with a circuit diagram for the series 2A Landover lightweight*
6. *The user and services manual with a circuit diagram for the Landover 110 ffr*

I am treating your correspondence as a request for information under the Freedom of Information Act 2000.

A search for the information has now been completed within the Ministry of Defence, and I can confirm that some information in scope of your request is held.

The information you have requested can be found below, but some of the information falls entirely within the scope of the absolute exemptions provided for at sections 21 (Information Reasonably Accessible to Applicant) and 40 (Personal Data), and qualified exemption provided for at section 26 (Defence) and has been redacted.

Section 21 (Information Reasonably Accessible to Applicant) has been applied to AESPs 0200-A-221-013 and 2300-A-050-013 because they have been published previously and can be found on the gov.uk publication site (link is included below).

Section 40(2) has been applied to some of the information in order to protect personal information as governed by the Data Protection Act 1998.

Sections 21 and 40 are absolute exemptions and there is therefore no requirement to consider the public interest in making a decision to withhold the information.

Section 26 is a qualified exemption and subject to public interest testing which means that the information requested can only be withheld if the public interest in doing so outweighs the public interest in disclosure.

Section 26(1)(b) has been applied to some of the information because it contains details which are operationally sensitive and would prejudice the capability and effectiveness of our armed forces. The balance of public interest was found to be in favour of withholding the information given that, overall, the public interest is best served in not releasing any details that would prejudice the security of UK personnel and which would provide tactical advantage to our enemies and for these reasons I have set the level of prejudice against release of the exempted information at the higher level of "would" rather than "would be likely to".

The information you requested regarded Merlin reports and vehicle histories is exempt under s21 of the FOI Act. The department has undertaken a routine review of the MERLIN archive and the final version of this has since been released as part of a previous FOI request, which can be accessed at:

<https://www.gov.uk/government/publications/foi-responses-published-by-mod-week-commencing-09-july-2018>

However, a search of our records showed no information is held on vehicles (VRNs) 35FG12, 27EN32, 81PK17 or 48FL17.

The information you requested for the documents is as follows:

1. AESP 0200-A-221-013 and 2. AESP 2300-A-300-532 are exempt under s21 and can be found at the following link:

https://assets.publishing.service.gov.uk/government/uploads/system/uploads/attachment_data/file/607174/Army_Equipment_Support_Publication_AESP_233-E202-522_GS_Cargo.pdf

3. AESP 2300-A-310-201 is attached below.

4. AESP 2300-A-600-013 is attached below.

5. Despite an extensive search of archives no documentation has been found for the 2A Land Rover lightweight. It is possible that the REME museum may be able to offer some assistance and they can be contacted at the following link:

enquiries@rememuseum.org.uk

6. AESP 2300-D-122-302 is attached below

Under Section 16 of the Act (Advice and Assistance) you may find it helpful to note the database in the above link for MERLIN is split into seven spreadsheets. The first has a list of vehicles, while sheets two through seven have the service histories. To search for a vehicle this can be done by pressing Ctrl + F, then typing the vehicle registration number, and then enter.

Furthermore, you may wish to note that when the MERLIN database was archived into its current format some data may have been lost or corrupted. You should, therefore, be cautious that some of the data may be inaccurate.

If you have any queries regarding the content of this letter, please contact this office in the first instance.

If you wish to complain about the handling of your request, or the content of this response, you can request an independent internal review by contacting the Information Rights Compliance team, Ground Floor, MOD Main Building, Whitehall, SW1A 2HB (e-mail CIO-FOI-IR@mod.gov.uk). Please note that any request for an internal review should be made within 40 working days of the date of this response.

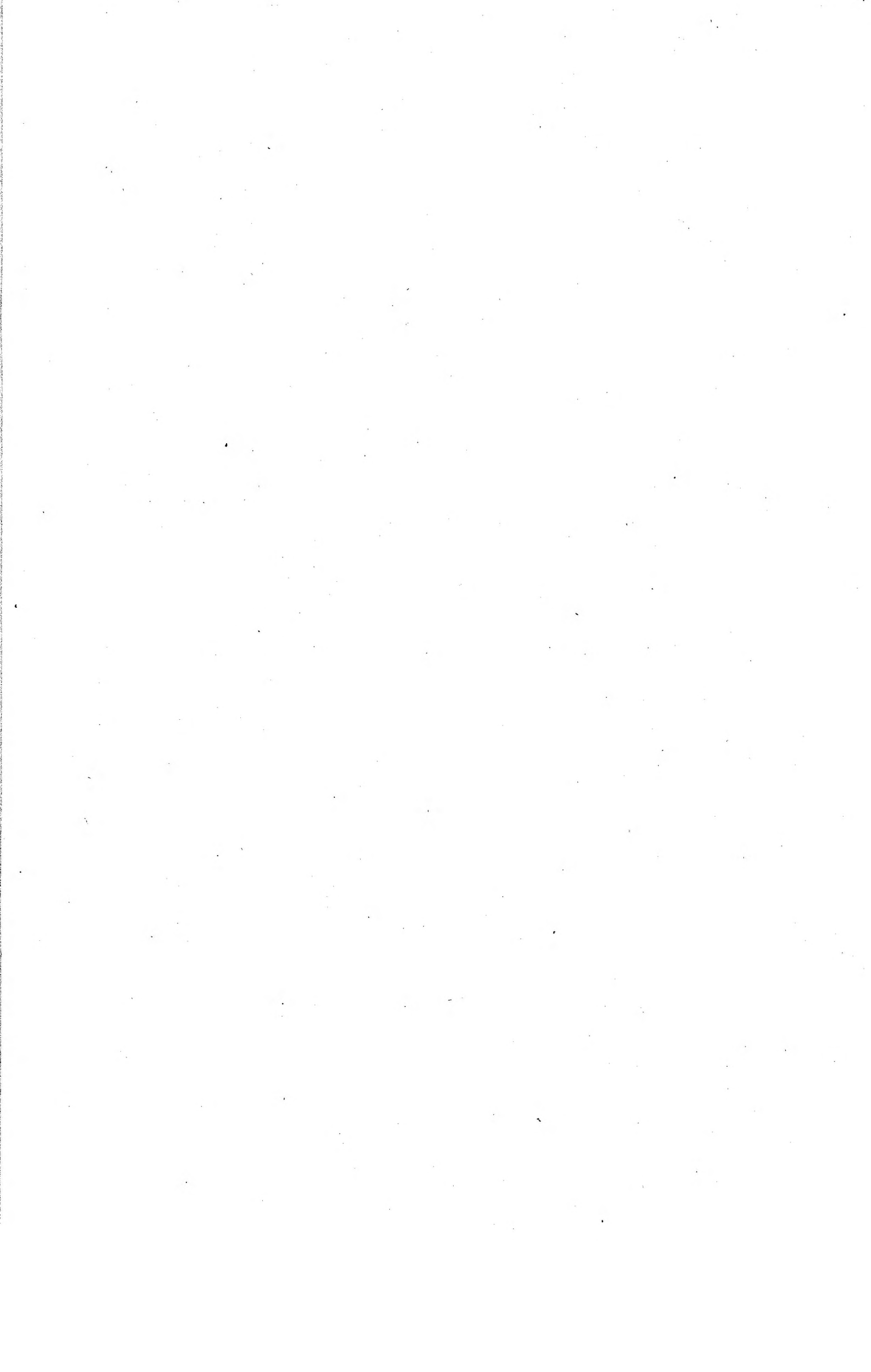
If you remain dissatisfied following an internal review, you may raise your complaint directly to the Information Commissioner under the provisions of Section 50 of the Freedom of Information Act. Please note that the Information Commissioner will not normally investigate your case until the MOD internal review process has been completed. The Information Commissioner can be contacted at: Information Commissioner's Office, Wycliffe House, Water Lane, Wilmslow, Cheshire, SK9 5AF. Further details of the role and powers of the Information Commissioner can be found on the Commissioner's website at <https://ico.org.uk/>.

Yours sincerely,

[Redacted signature]

[Redacted name]

DES SEC Pol Sec Land Equipment





Note:

*Retain 1st Edition until
Category 522 is issued*

**FOR OFFICIAL USE ONLY
CROWN COPYRIGHT RESERVED**

The information within this publication is released by
the UK Government to the recipient in accordance with
the Conditions of Release at Page (ii)

**LAND ROVER 90/110/127,
ALL VARIANTS
(EXCLUDING APV, SAS
AND 127 CRASH RESCUE
AMBULANCE)**

REPRINTED INCORPORATING AMNDTS 1-7

TECHNICAL DESCRIPTION

BY COMMAND OF THE DEFENCE COUNCIL

Ministry of Defence

**LAND SYSTEMS TECHNICAL PUBLICATIONS AUTHORITY
Royal Arsenal West, Woolwich,
London SE18 6ST**

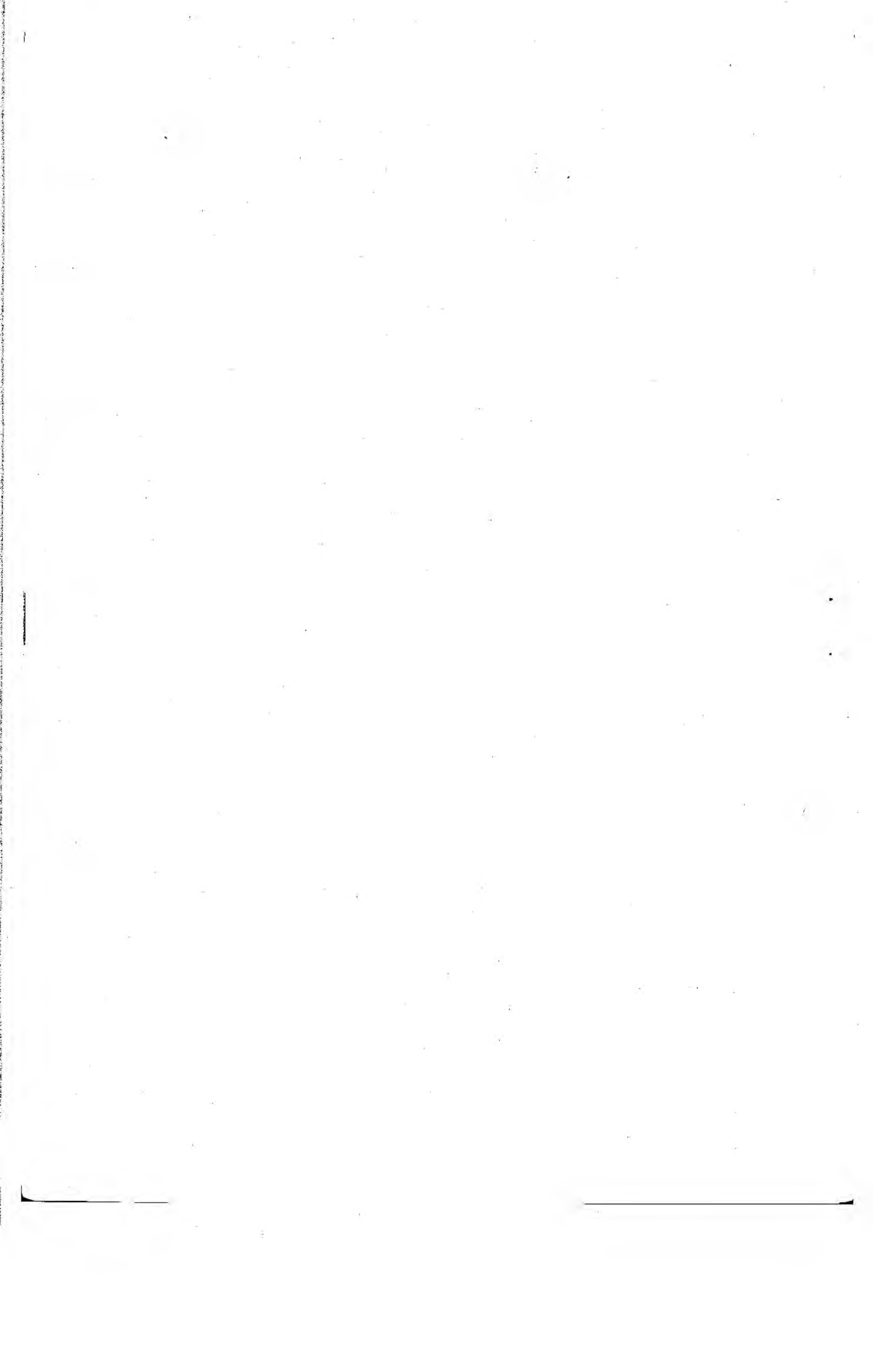
CONDITIONS OF RELEASE

1. This information is released by the UK Government for Defence purposes only.
2. This information must be accorded the same degree of security protection as that accorded thereto by the UK Government.
3. This information may be disclosed only within the Defence Department of the recipient Government, except as otherwise authorized by the Ministry of Defence (Army).
4. This information may be subject to privately owned rights.

AMENDMENT RECORD

Amdt No	Incorporated By (Signature)	Date
1	INCORPORATED	
2	INCORPORATED	
3	INCORPORATED	
4	[REDACTED]	2/11/97
5	[REDACTED]	17/10/98
6	[REDACTED]	10/3/99
7	[REDACTED]	20/11/00
8	[REDACTED]	
9		
10		
11		
12		
13		
14		
15		
16		
17		
18		
19		
20		
21		
22		
23		
24		
25		
26		
27		
28		
29		
30		
31		

Amdt No	Incorporated By (Signature)	Date
32		
33		
34		
35		
36		
37		
38		
39		
40		
41		
42		
43		
44		
45		
46		
47		
48		
49		
50		
51		
52		
53		
54		
55		
56		
57		
58		
59		
60		
61		
62		



CONTENTS

	Page
PRELIMINARY MATERIAL	
Title page (front cover)	(i)
Conditions of release	(ii)
Amendment Record Sheet	(iii)/(iv)
Contents (this List)	(v)
PREFACE	
Introduction	(vi)
Related and Associated Publications	(vi)
TECHNICAL DESCRIPTION	
CHAPTERS	
1 Engines	
1-1 2.5 litre diesel engine	
1-2 3.5 litre petrol engine	
1-3 2.5 litre diesel engine breather system	
2 Clutches	
2-1 Clutch 2.5 litre diesel 90 and 110	
2-2 Clutch 3.5 litre petrol 110 and 127	
3 Gearboxes	
3-1 LT77 five speed manual gearbox	
3-2 LT85 five speed manual gearbox	
3-3 LT85 lightweight divided-case manual gearbox	
4 Transmission (Transfer)	
5 Rear axles	
5-1 Salisbury type - 8HA	
5-2 Land Rover heavy duty	
6 Front axles	
6-1 Front axle 2.5 litre diesel 90 and 110	
6-2 Front axle 3.5 litre petrol 110 and 127	
7 Steering systems	
7-1 Manual steering system	
7-2 Power assisted system	
8 Suspension	
8-1 Suspension 90/110 vehicles	
8-2 Suspension 127 vehicles (Heavy duty)	
9 Wheels and tyres (NTU)	
10 Braking system	
11 Fuel systems	
11-1 Diesel fuel system	
11-2 Petrol fuel and exhaust system	
11-3 Pulsair system (derated engine)	
12 Cooling system	
12-1 2.5 litre diesel cooling system 90/110	
12-2 3.5 litre petrol cooling system 110/127	
12-3 Winterised cooling system	
█	
█	
█	
█	
█	
█	
14 Hydraulic system (NTU)	
15 Chassis	
15-1 Chassis 90 and 110 vehicles	
15-2 Chassis 127 vehicles	
16 Body and cab fittings (NTU)	
17 Electrical winch 127 vehicles	
18 Heating and ventilation	
18-1 Heating and ventilation system	

PREFACE**Sponsor : LSOR3C****INTRODUCTION**

1. Service users should forward any comments on this publication through the channels prescribed in AESP 0100-P-011-013.
2. The subject matter of this publication may be affected by Defence Council Instructions (DCIs), Standing Operating Procedures (SOPs) or by local regulations. When any such Instruction, Order or regulation contradicts any portion of this publication it is to be taken as the overriding authority.
3. For periods of servicing and lubricants to be used reference must be made to the Maintenance Schedule.

RELATED AND ASSOCIATED PUBLICATIONS**Related publications**

4. The Octad for the subject equipment consists of the publications shown below. All references are prefixed with the first eight digits of this publication.

CATEGORIES AND INFORMATION LEVELS														
Category	1	2	3	4		5				6	7		8	
				1	2	1	2	3	4		1	2	1	2
1 USER/OPERATOR	101	201	201	*	*	201	201	*	*	601	711	721	*	*
2 UNIT MAINTENANCE	*	*	302	*	*	512	522	532	*	*	*	*	*	*
3 FIELD MAINTENANCE	*	*	302	*	*	512	522	532	*	*	*	*	*	*
4 BASE MAINTENANCE	*	*	302	*	*	512	524	534	*	*	*	*	*	*

- | | |
|------------------------------------|---------------------------------|
| 1.0 Purpose & Planning Information | 5.3 Inspection Standards |
| 2.0 Operating Information | 5.4 Calibration Procedures |
| 3.0 Technical Description | 6.0 Maintenance Schedules |
| 4.1 Installation Instructions | 7.1 Illustrated Parts Catalogue |
| 4.2 Prep for Special Environments | 7.2 Commercial Parts List |
| 5.1 Failure Diagnosis | 8.1 Modification Instructions |
| 5.2 Repair Instructions | 8.2 General Instructions |

* Not published

Reference to relevant Group Index (see AESP 0100-A-001-013) must be made to ensure the availability of the listed publications.

Associated publications

5.	Code No	Type	Title
	2910-F-101-302	AESP	CAV FUEL INJECTION PUMP DPS
	2920-C-102-302	AESP	GENERATOR No 16 MK 1, 90 Amp (LUCAS, CAV, AC 172)

Chapter 1

ENGINES

TECHNICAL DESCRIPTION

INTRODUCTION

1 This Chapter gives the technical descriptions for engines fitted to Land Rover 2.5 litre diesel 90 and 110 vehicles, and Land Rover 3.5 litre petrol 110 and 127 vehicles.

2 The Chapter has been Sub-chaptered as follows to accommodate the engine fitted to Land Rover 2.5 litre diesel 90 and 110 vehicles, and the engine fitted to Land Rover 3.5 litre petrol 110 and 127 vehicles.

Chapter 1-1 2.5 LITRE DIESEL ENGINE

Chapter 1-2 3.5 LITRE PETROL ENGINE

Chapter 1-3 2.5 LITRE DIESEL ENGINE BREATHER SYSTEM

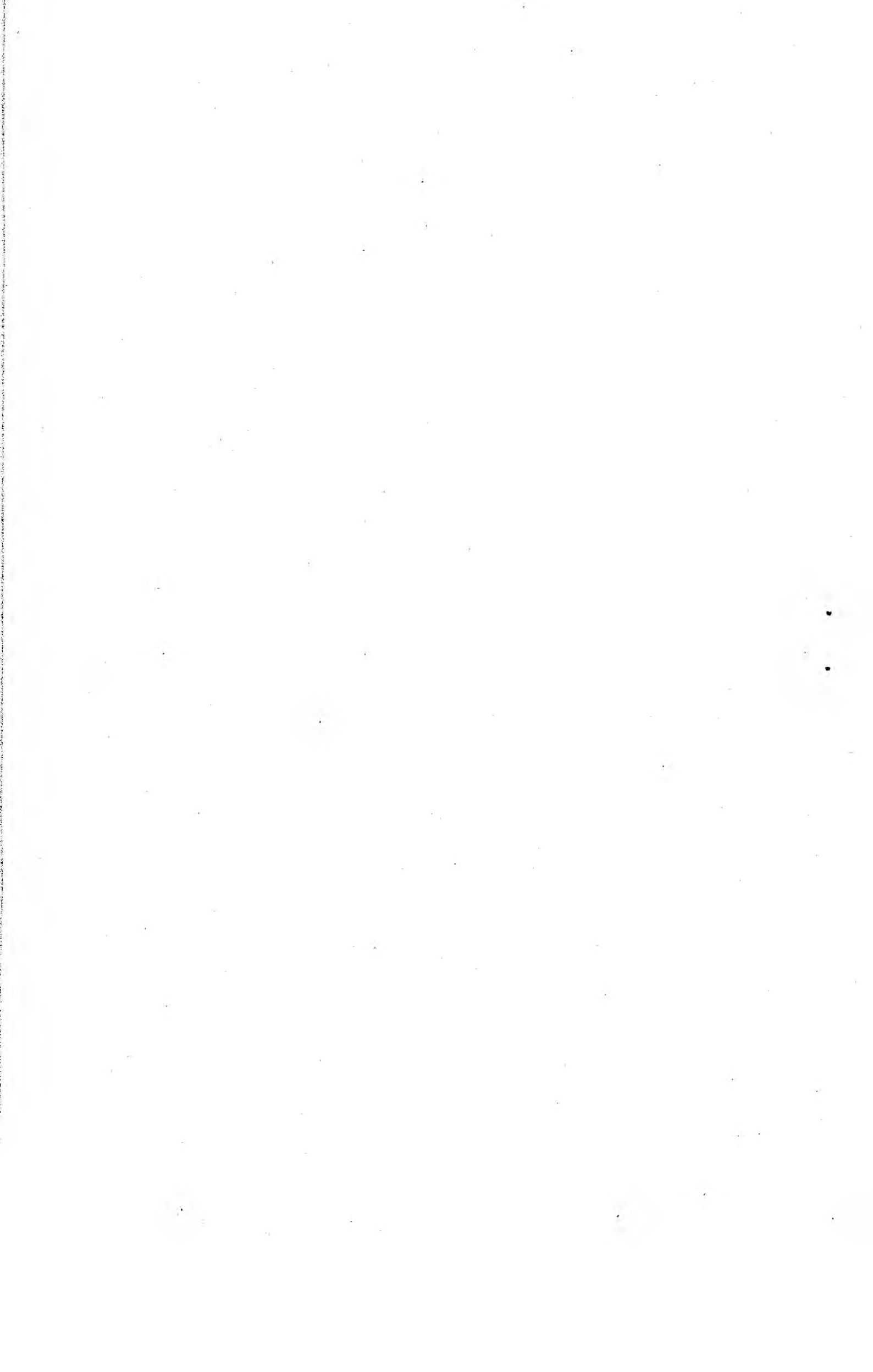
General

3 The information given is applicable to both left and right drive vehicles. Throughout the chapter the following terms are used to describe the location of components on the engine, when the engine is out of the vehicle.

3.1 Drive end - The end from which the drive is taken, i.e. the flywheel end.

3.2 Front - The end to which the crankshaft pulley is fitted, i.e. opposite to the drive end.

3.3 Left and Right sides - The sides are as viewed from the drive end of the engine.



Chapter 1-1

ENGINE 2.5 LITRE DIESEL

CONTENTS

Frame Para

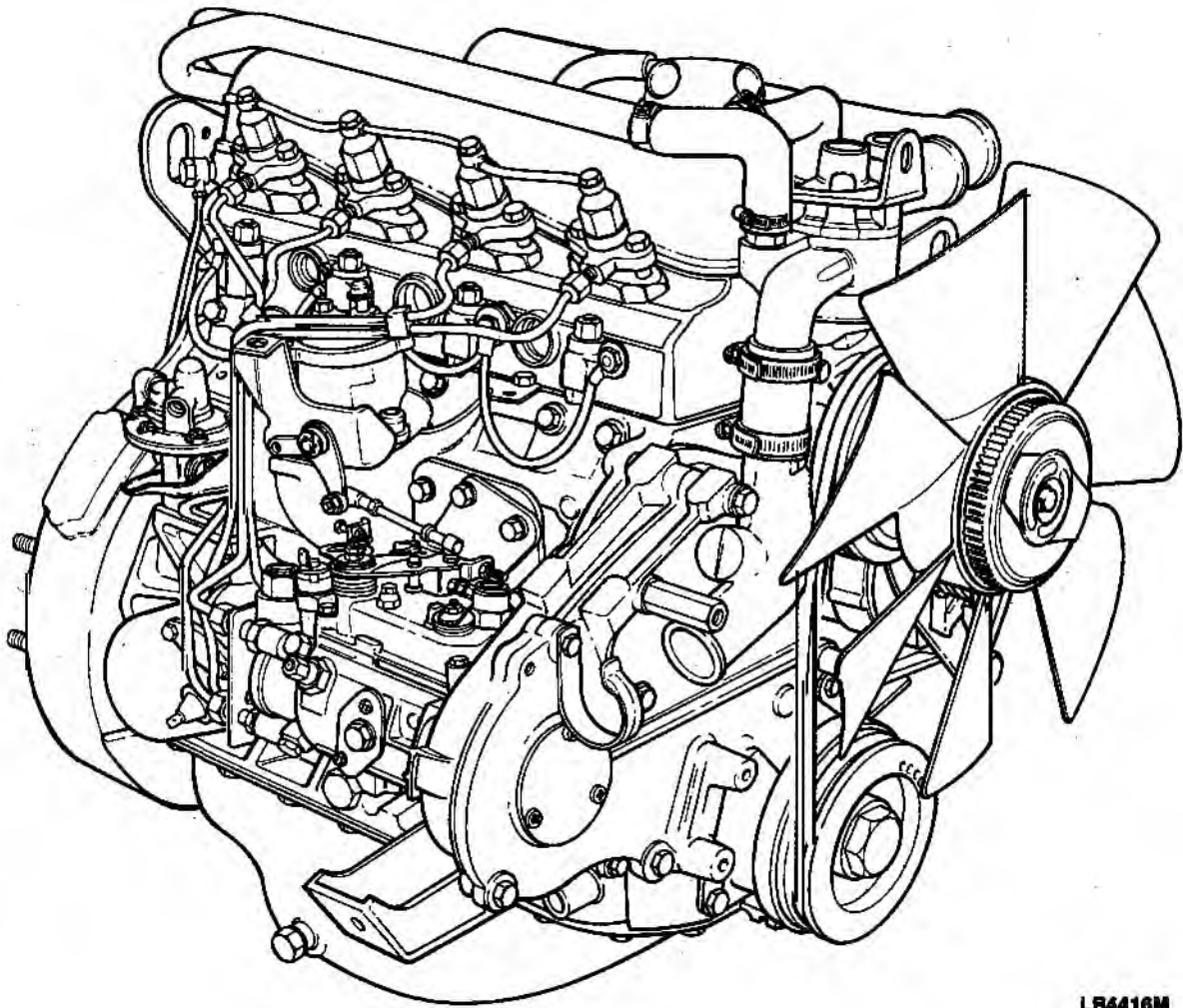
Engine

1	General
2	Cylinder block
4	Crankshaft and main bearings
8	Flywheel assembly
11	Flywheel housing
12	Camshaft
13	Tappets
14	Connecting rods and pistons
17	Cylinder head
18	Valves
19	Rocker shaft assembly
21	Operation
22	Valve tip clearances
23	Rocker cover
24	Timing case and pulleys
	Engine lubrication
28	General
29	Oil circulation
34	Oil cooling (12/24 volt only)
35	Oil pump
36	Oil filter
37	Oil cooler (12/24 volt only)

Fig

Page

1	2,5 Litre diesel engine	2
2	Crank shaft	3
3	Flywheel assembly	4
4	Camshaft and pulley	5
5	Tappets	6
6	Piston and connecting rod	7
7	Exploded view of cylinder head	8
8	Timing belt, pulleys, covers and water pump	11
9	Engine oil circulation	12
10	Oil pump	14



LR4416M

Fig 1 2,5 Litre diesel engine

ENGINE

General

1 The engine (Fig 1) is a Land Rover diesel 2.5 litre, 4 cylinder in line, compression ignition, overhead valve, liquid cooled unit having a nominal bore of 90,47 mm (3.562 in) and a stroke of 97,0 mm (3.819 in).

Cylinder block

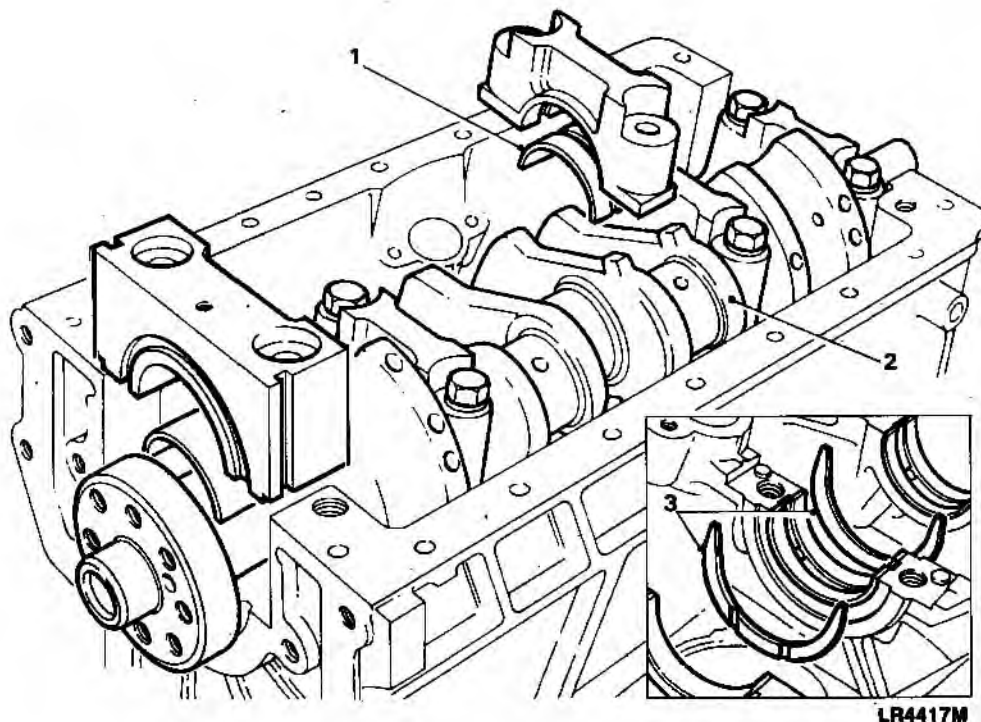
2 The cylinder block is of cast iron and is integral with the crankcase.

3 The cylinder bores are unlined but may be rebored and fitted with liners at overhaul.

Crankshaft and main bearings

4 The crankshaft (Fig 2 (2)) runs in five pre-finished replaceable shell bearings (1).

5 End float of the crankshaft is controlled by thrust washers (3) which are located on both sides of the centre main bearing housing. Oversize thrust washers are available which may be combined with standard thrust washers to obtain the correct end float, provided that the difference between the thrust washers is not more than 0.08 mm (0.003 in).



1 Shell bearing

2 Crankshaft

3 Thrust washers

Fig 2 Crankshaft

6 The front end of the crankshaft has a pulley fitted which incorporates a torsional vibration damper.

7 The crankshaft at the drive end has provision for eight fixing bolts for attaching the flywheel.

Flywheel assembly

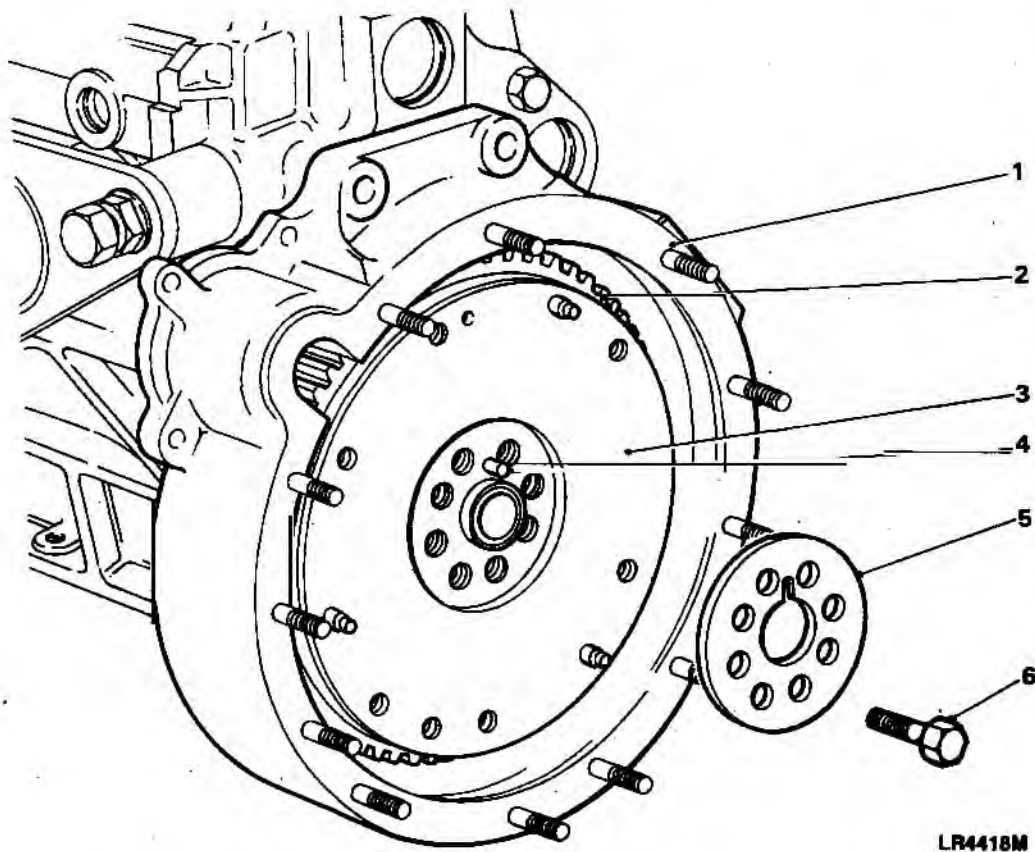
8 The flywheel assembly (Fig 3) consists of the flywheel and a starter ring gear.

9 The flywheel (3) is a steel forging and is secured to the crankshaft by eight set screws (6) a reinforcing plate (5) and a locating dowel (4) .

10 The starter ring gear (2) is shrunk onto the flywheel. The ring is heated to 240°C (464°F) prior to assembly and is slipped over the flywheel.

Flywheel housing

11 The flywheel housing (1) is an aluminium alloy casting secured to the rear of the crankcase, it also forms the mounting for the engine starter motor. A plugged aperture on the upper right hand side of the housing, allows access for engine timing.

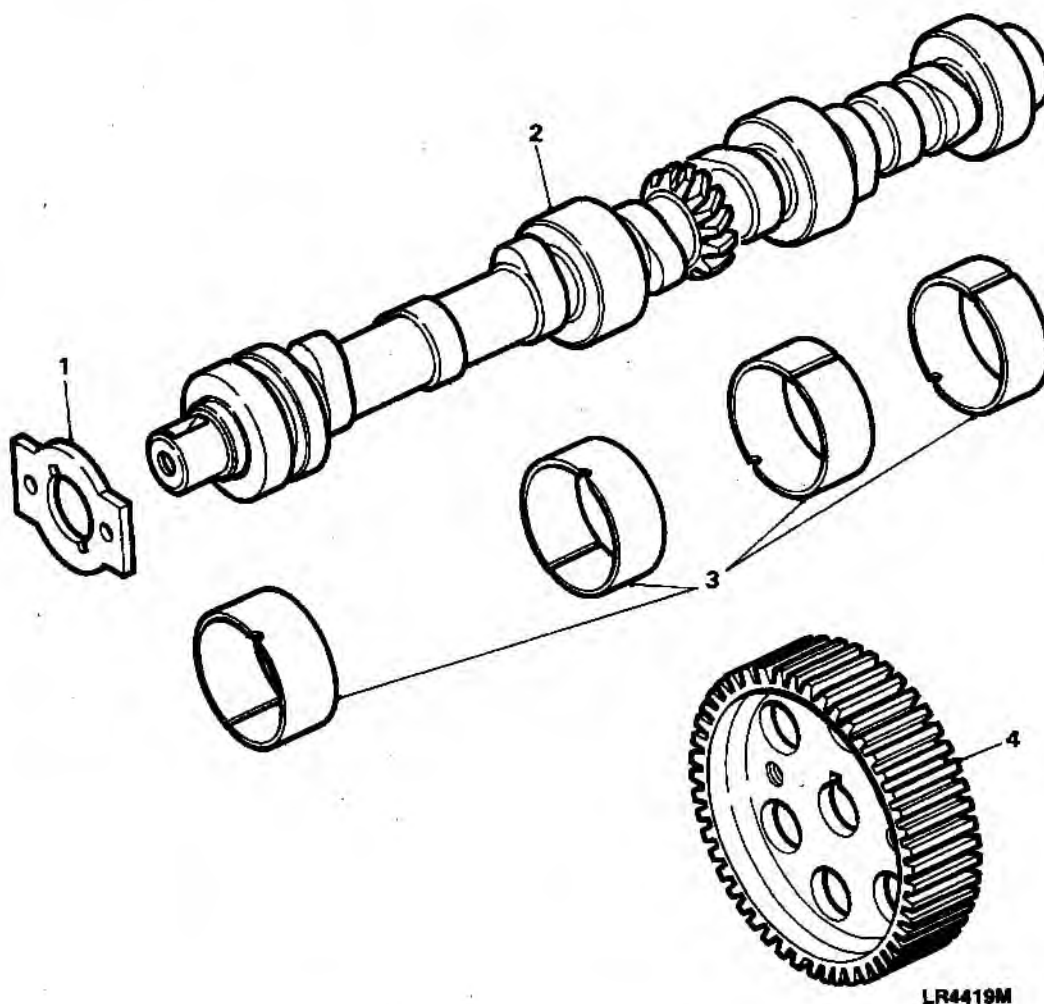


- | | | | |
|---|-------------------|---|-------------------|
| 1 | Flywheel housing | 4 | Dowel |
| 2 | Starter ring gear | 5 | Reinforcing plate |
| 3 | Flywheel | 6 | Setscrew |

Fig 3 Flywheel assembly

Camshaft

12 The camshaft (Fig 4 (2)) is supported by four bearings (3) and is driven by a pulley (4) and toothed belt from the crankshaft, a skew gear formed between the two inner bearing journals provides drive for the oil and vacuum pumps. Camshaft end float is controlled by a thrust plate (1) bolted to the cylinder block.



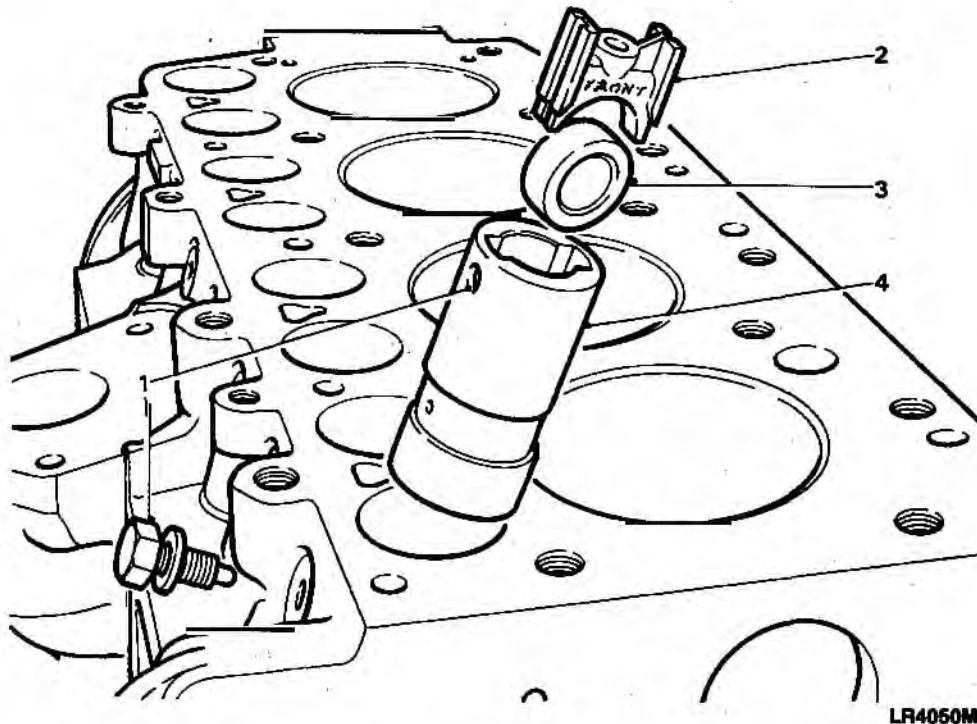
1 Thrust washer
2 Camshaft

3 Bearings
4 Camshaft pulley

Fig 4 Camshaft and pulley

Tappets

13 The tappets (Fig 5) are of the roller and slide type operating in a guide fitted to the cylinder block.



- | | | | |
|---|----------------------|---|--------|
| 1 | Screw guide locating | 3 | Roller |
| 2 | Slide | 4 | Guide |

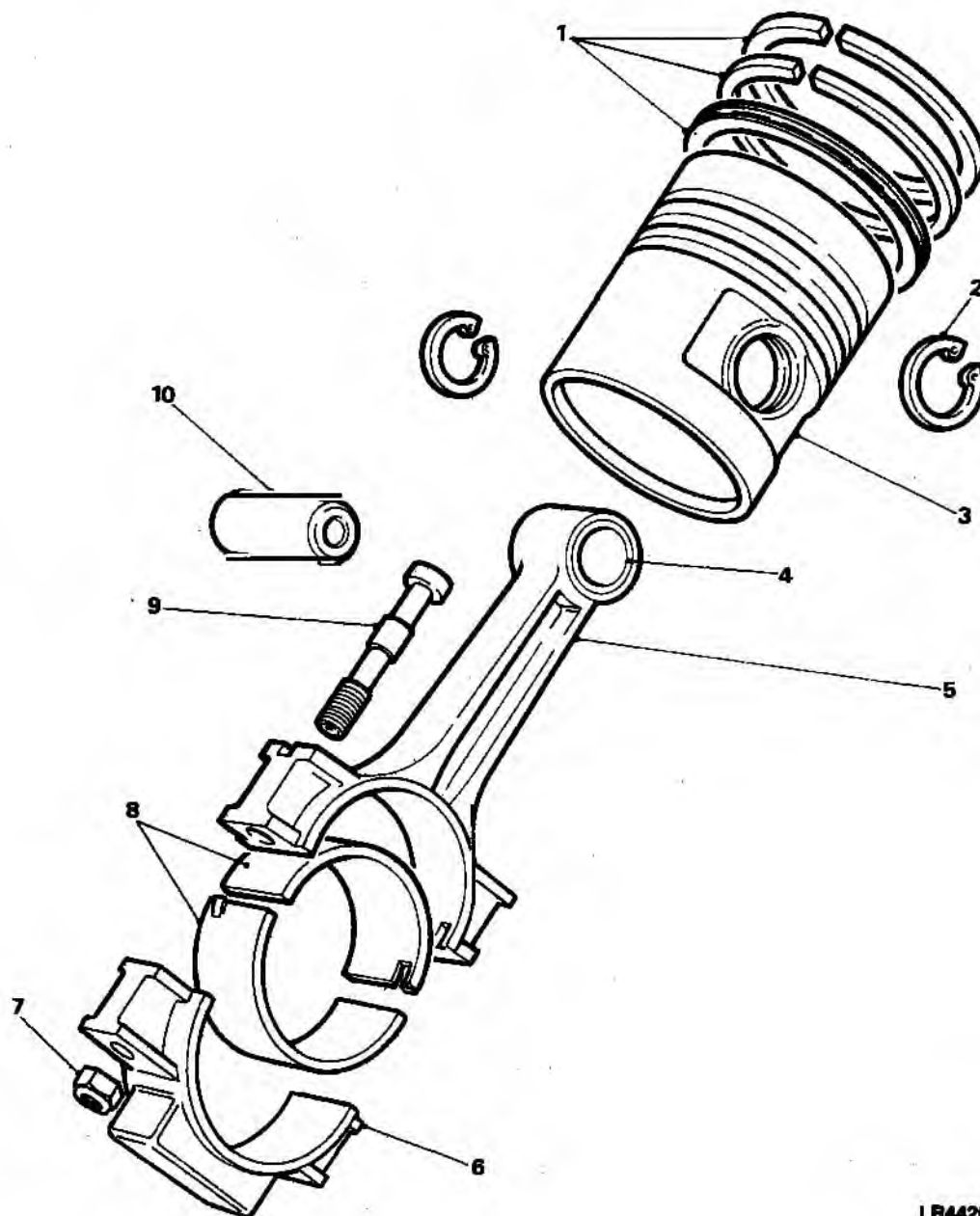
Fig 5 Tappets

Connecting-rods and pistons

14 The connecting-rod and piston assemblies are shown in Fig 6. Shell bearings (8) are fitted to the big ends and bushes (4) to the small ends. The pistons (3), connecting rods (5) and caps (6) are marked with their relevant cylinder number and should be kept together as an assembly with their associated big end bearings.

15 The pistons are secured to the small end by means of a gudgeon pin (10) and circlips (2). The connecting rod caps (6) are secured by two bolts (9) and nuts (7).

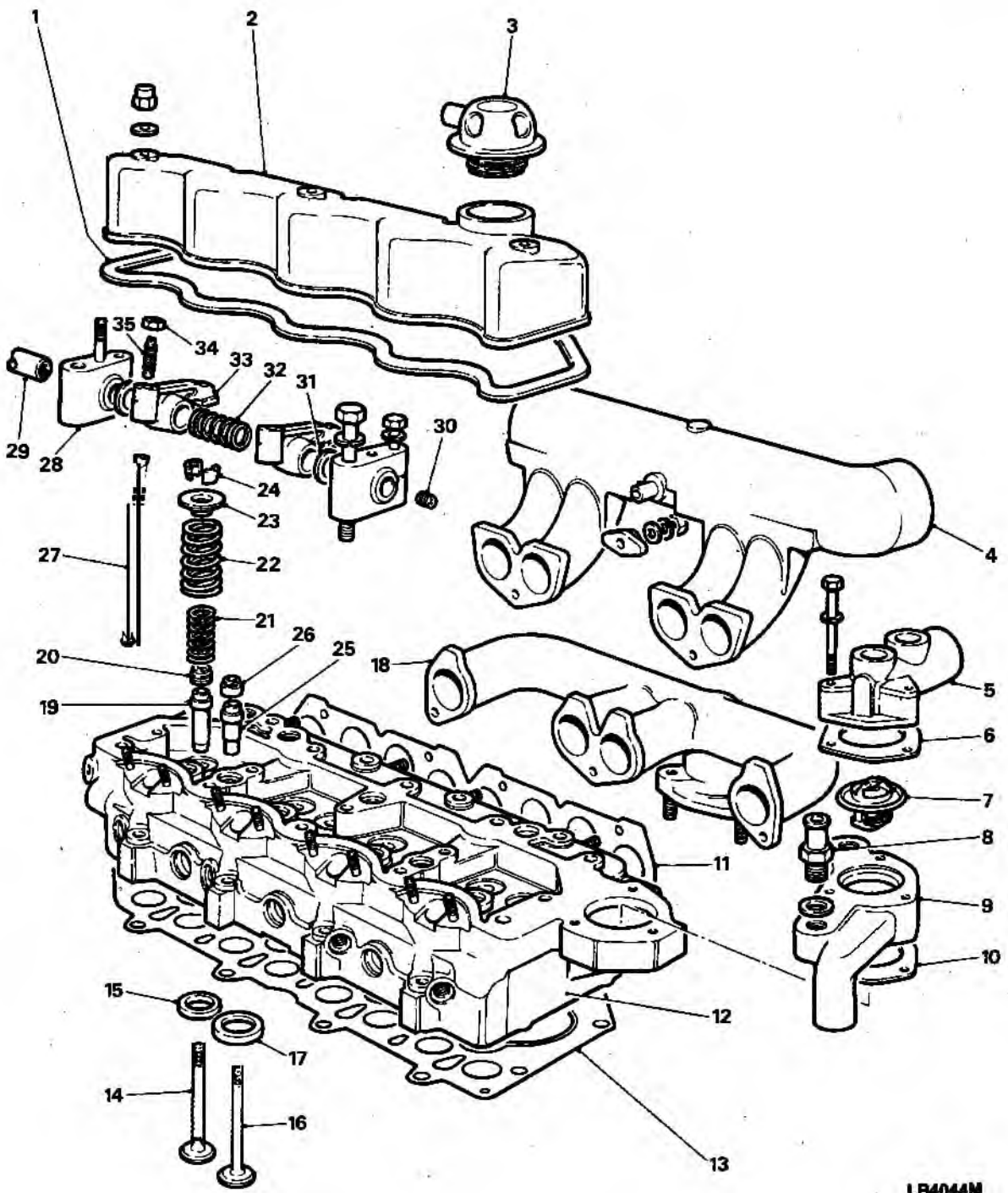
16 The pistons incorporate a 'V' trough cast in the crown to improve turbulence. Each piston has three rings (1) fitted, the top ring is a square friction edge chrome plated type. The middle ring is a bevelled friction edge type, marked 'TOP' on the upper side. The bottom ring is the oil control and is of the S E O C (Spring Expander Oil Control) conformable type.



LR4420M

- | | | | |
|---|----------------|----|--------------------|
| 1 | Piston rings | 6 | Connecting rod cap |
| 2 | Circlip | 7 | Retaining nut |
| 3 | Piston | 8 | Bearing |
| 4 | Bush | 9 | Retaining bolt |
| 5 | Connecting rod | 10 | Gudgeon pin |

Fig 6 Piston and connecting rod



LR4044M

Fig 7 Exploded view of cylinder head

Key to Fig 7

1	Gasket-rocker cover	19	Exhaust valve guide
2	Rocker cover	20	Oil seal-valve guide
3	Oil filler cap	21	Inner valve spring
4	Inlet manifold	22	Outer valve spring
5	Cover-thermostat housing	23	Valve spring retainer
6	Gasket	24	Split collets
7	Thermostat	25	Inlet valve guide
8	By-pass adaptor	26	Oil seal-valve guide
9	Thermostat housing	27	Push rod
10	Gasket	28	Rocker bracket
11	Manifold gasket	29	Rocker shaft
12	Cylinder head	30	Rocker shaft plug
13	Cylinder head gasket	31	Spacer
14	Exhaust valve	32	Spring
15	Exhaust valve seat	33	Rocker lever
16	Inlet valve	34	Locknut
17	Inlet valve seat	35	Adjusting screw
18	Exhaust manifold		

Cylinder head

17 The cylinder head (Fig 7 (12)) is jacketed for the circulation of coolant and is secured to the cylinder block by bolts and through studs. The head is fitted with guides (19) and (25) and seats (15) and (17) for the valves, tubes for the push rods and shrouds and hot plugs at the injector locations.

Valves

18 The valve assembly consists of a valve (14), split collets (24), spring retainer (23), inner and outer springs and an oil seal (20). The outer spring (22) is left hand coiled and the inner spring (21) is right hand coiled.

Rocker shaft assembly

19 The rocker shaft assembly consists of rocker levers (33), mounted on a hollow shaft (29) carried in four support brackets (28), springs (32) are interposed between the rocker levers. Each rocker lever is fitted with a bush and an adjustment screw (35) and locknut (34).

20 The rocker shaft assembly is secured to the cylinder head by bolts through the support brackets. Support brackets numbers one three and five are fitted with studs for securing the rocker cover, number two support bracket is fitted with a locating screw and spring washer. The locating screw connects with a corresponding bore in the rocker shaft to ensure correct spacing of the rocker levers on the shaft.

Operation

21 The valves are opened by the rocker levers which are operated by the push rods which in turn are operated through the tappets by the camshaft. The valves are opened at timed intervals. With the rocker levers acting upon the valves, pressure is exerted on the valves, compressing the springs and thus opening the valves. As pressure from the lever is released, the springs return to their original position thus closing the valves.

Valve tip clearances

22 The valve tip clearances are set at 0,25mm (0.010in) for both inlet and exhaust valves.

Rocker cover

23 The rocker cover is secured to the cylinder head by three cap nuts and is sealed by a replaceable gasket. The cover incorporates the oil filler cap and breather.

Timing case and pulleys

24 The timing case (Fig 8) consists of front and rear covers. The cast aluminium alloy rear cover (5) incorporates housings for the crankshaft and camshaft oil seals, the upper portion of the casting forms the mounting for the cooling system water pump (15). The rear cover is secured to the front of the cylinder block (1) and is sealed by gaskets.

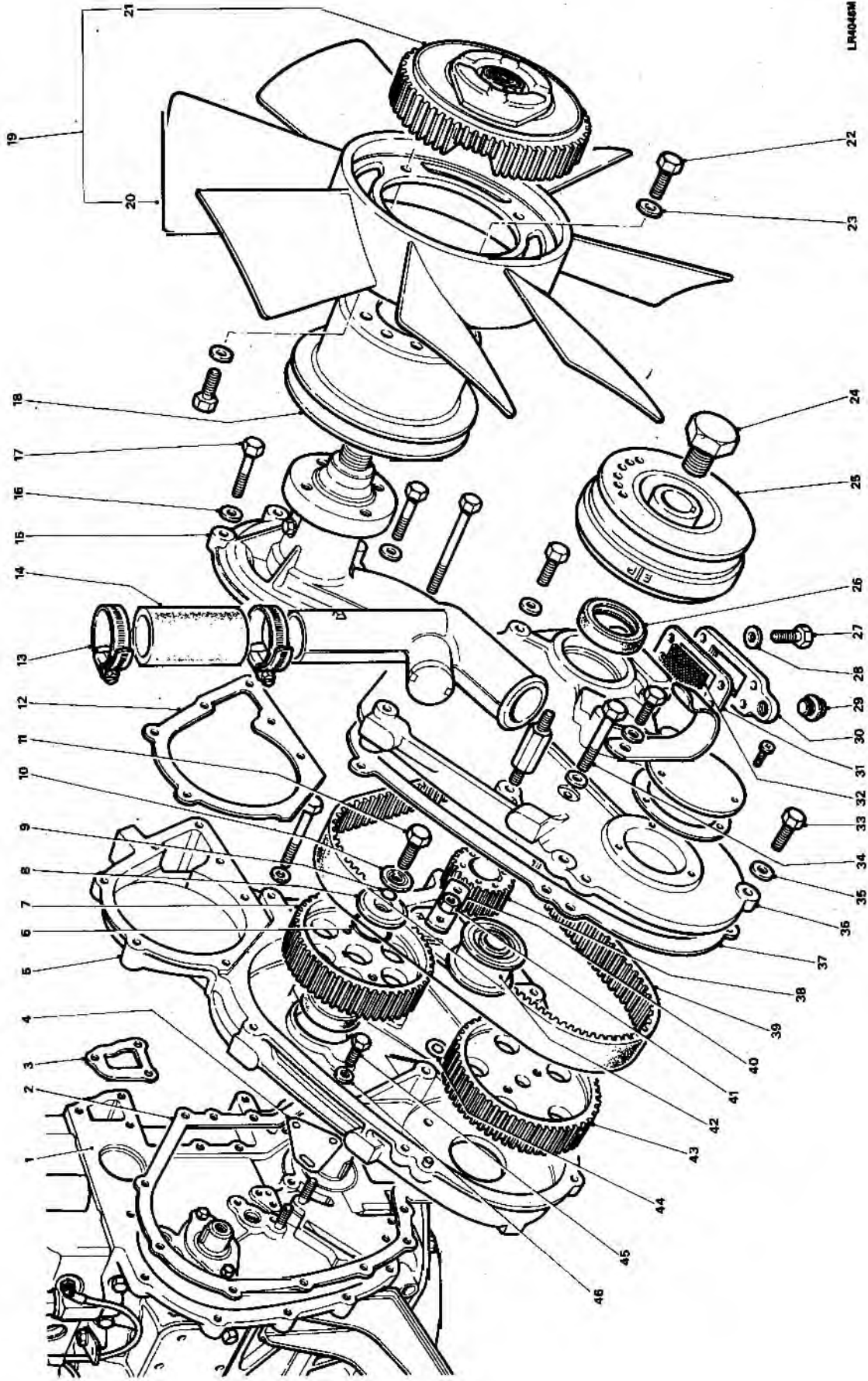
25 The front cover (36) is also an aluminium alloy casting and incorporates a housing for the front crankshaft oil seal and an inspection aperture. A vent (30) and after wading drain plug (29) are situated at the bottom of the front cover.

26 Three pulleys are housed within the case, the crankshaft pulley, (38) which provides the drive for the camshaft (7) and DPS pump (43) pulleys via a rubber timing belt (39), correct belt tension is achieved by an adjustable jockey pulley (42).

27 The rear cover and pulleys are marked with timing points to facilitate correct timing of the engine.

Key to Fig 8

1	Cylinder block	24	Bolt-crankshaft pulley
2	Gasket-rear cover	25	Crankshaft pulley
3	Gasket-water gallery	26	Oil seal
4	Gasket-triangular	27	Bolt-vent bracket
5	Rear cover	28	Washer-vent bracket
6	'O' ring seal	29	Wading plug
7	Camshaft pulley	30	Bracket-vent
8	Special washer	31	Gasket-vent bracket
9	'O' ring seal	32	Gauze-vent bracket
10	Plain washer	33	Bolt-front cover securing
11	Bolt-camshaft	34	Centre bolt-front cover
12	Gasket-water pump	35	Plain washer
13	Hose clip	36	Front cover
14	By-pass hose	37	Gasket-front cover
15	Water pump	38	Crankshaft timing pulley
16	Plain washer	39	Timing belt
17	Bolt-water pump	40	Clamp belt tensioner
18	Pulley-fan/water pump	41	Nut-belt tensioner clamp
19	Fan and viscous coupling assy.	42	Tensioner
20	Fan	43	DPS pump pulley
21	Viscous coupling	44	Fibre washer
22	Bolt-pulley to water pump	45	Bolt-rear cover
23	Plain washer	46	Plain washer



LR04048H

Timing belt, pulleys, covers and water pump

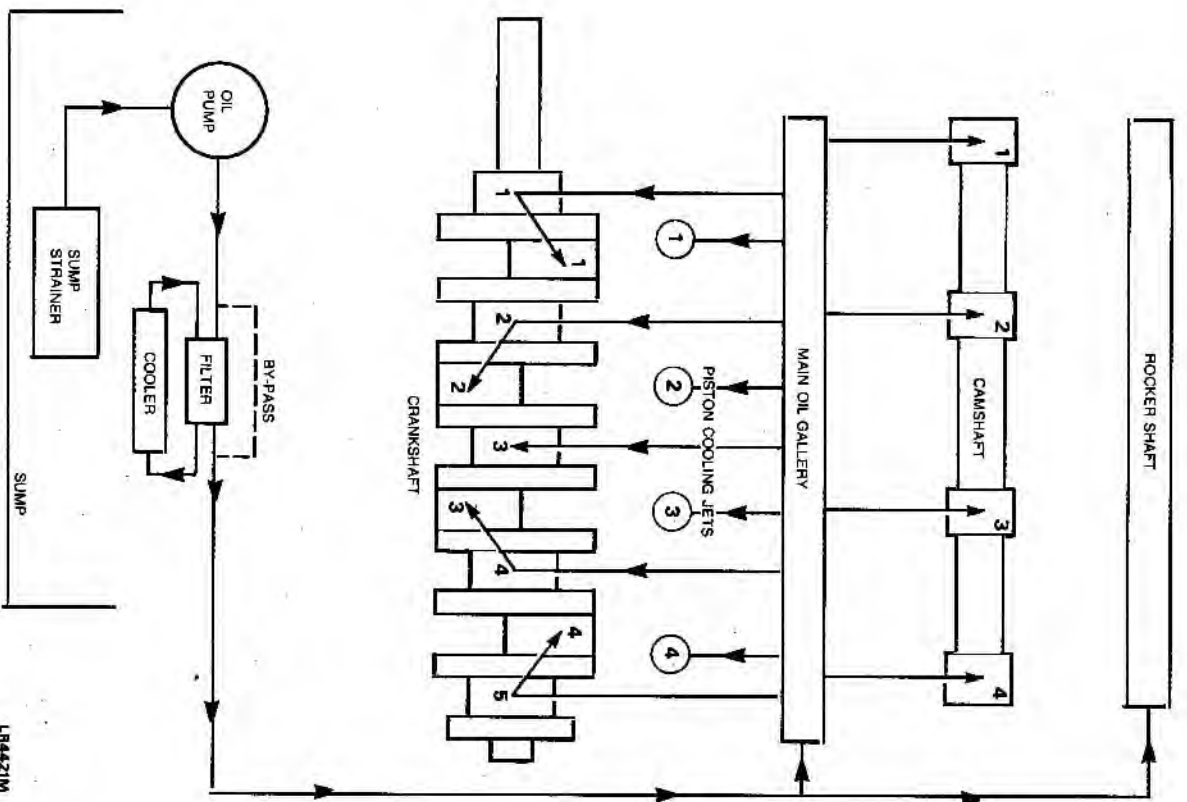


Fig 9 Engine oil circulation

ENGINE LUBRICATION

General

28 Engine lubrication is of the wet sump type, oil pressure is provided by a gear type pump driven by a skew gear on the camshaft.

Oil circulation (Fig 9)

29 The oil pump draws oil from the sump through the suction pipe and strainer and passes it through internal drillings in the cylinder block to an externally mounted full flow filter. Further drillings feed the oil to the main oil gallery drilled the length of the cylinder block.

30 Drillings, in the cylinder block webs, feed oil from the main gallery to the main bearings, and cross drillings in the crankshaft carry oil to the connecting rod big end bearings. The camshaft bearings are lubricated by oil being fed through drillings from the main gallery.

31 An external pipe, connected between the cylinder block and head, feeds oil to the rocker shaft assembly which escapes through a small bleed hole in each rocker lever to lubricate the valves and springs.

32 The pistons are cooled by lubricating oil being sprayed on them by cooling jets taking their feed from the main oil gallery via relief valves which allow the oil to flow at a pre-determined pressure.

33 Oil pressure is controlled by a pressure relief valve incorporated within the oil pump that allows excess oil to return to the sump.

Oil cooling (12/24V only)

34 Oil cooling is achieved by the fitment of an adaptor to the full flow filter head, a thermostat within the adaptor allows oil to flow to the cooler when it reaches a pre-determined temperature. Cooled oil is returned to the engine through a second adaptor in the filter head.

Oil pump

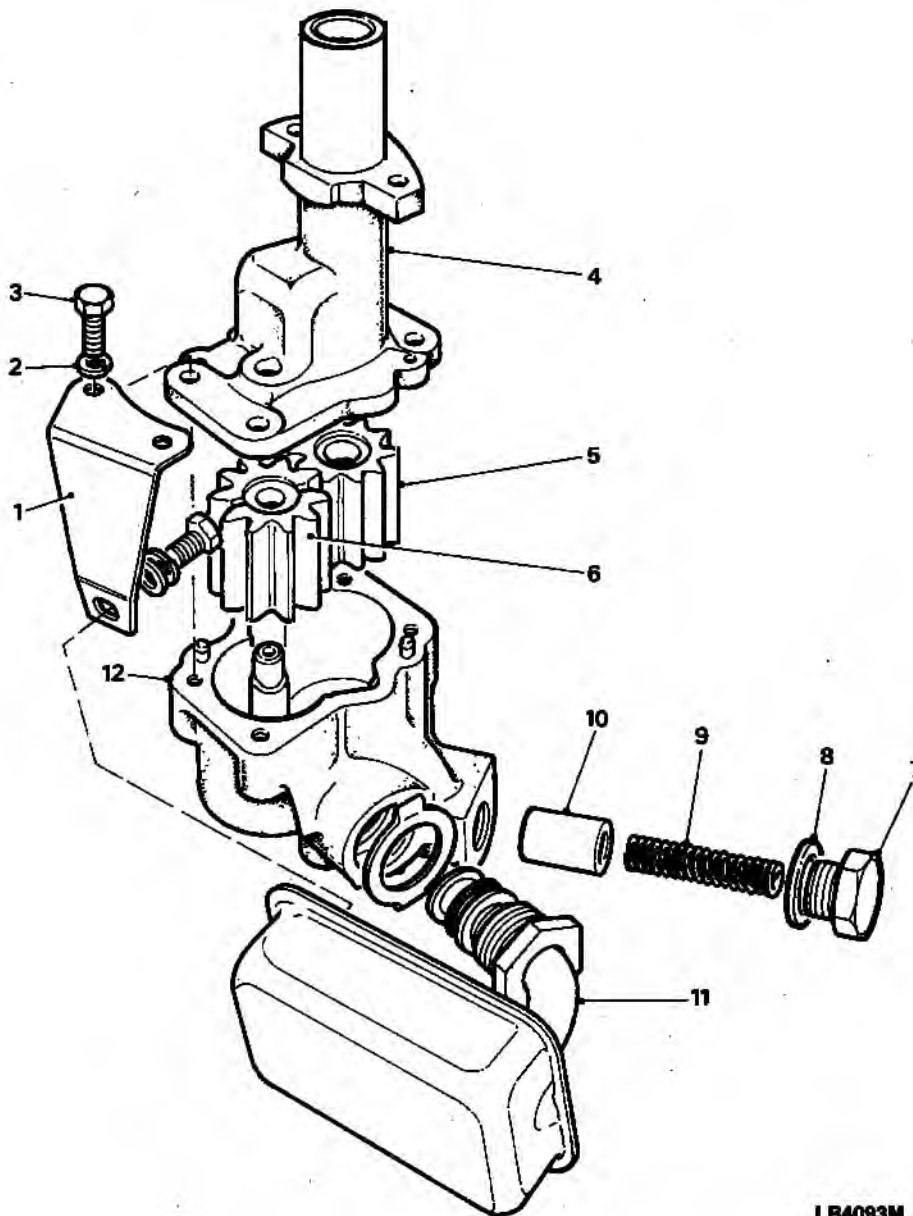
35 The oil pump is a conventional gear type pump, driven by a splined shaft and coupling, in mesh with a skew gear formed on the camshaft, and is secured to the crankcase by two set screws. It consists of two gears, one drive (Fig 10 (5)) and one idler (6), housed in the pump body (12). The sump strainer (11) and combined suction pipe is connected to the pump body and is supported by a bracket (1) attached to the cover (4) and strainer. A pressure relief valve is situated in the pump body.

Oil filter

36 The oil filter is a full flow single element canister type, and is mounted on the right hand side of the engine. A by-pass valve is incorporated in the filter head to ensure the passage of oil should the filter become blocked.

Oil cooler (12/24V only)

37 The oil cooler is mounted in an 'A' frame attached to cross tubes in front of the vehicle radiator. The oil cooler is an assembly of five 'U' tubes connected between an input reservoir and an output reservoir. Air drawn into the matrix cools the oil as it passes through the 'U' tubes before returning to the output reservoir.



LR4093M

- | | | | |
|---|-----------------|----|----------------------|
| 1 | Support bracket | 7 | Relief valve plug |
| 2 | Washers | 8 | Sealing washer |
| 3 | Bolts | 9 | Relief valve spring |
| 4 | Cover | 10 | Relief valve plunger |
| 5 | Driven gear | 11 | Strainer |
| 6 | Idler gear | 12 | Body |

Fig 10 Oil pump

Chapter 1-2

3.5 LITRE PETROL ENGINE

TECHNICAL DESCRIPTION

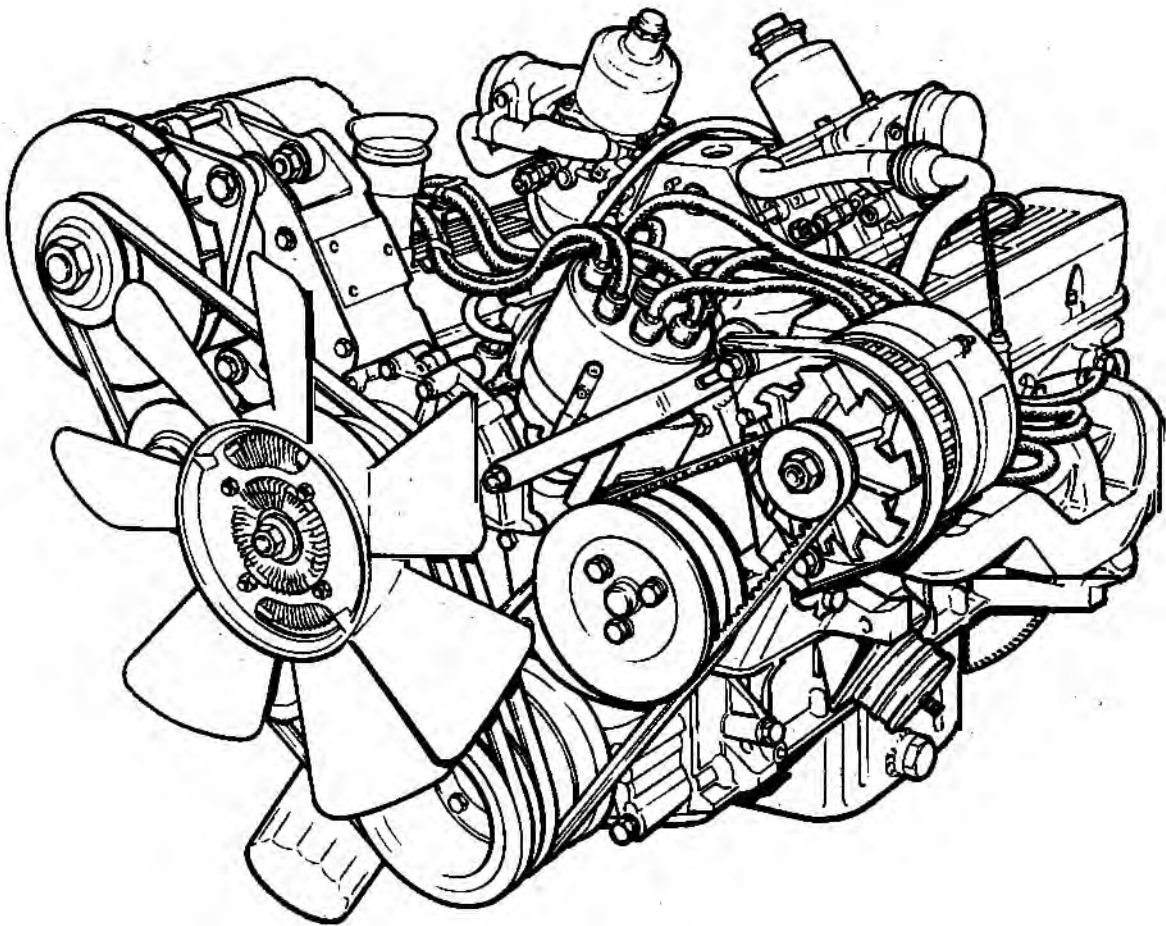
CONTENTS

Para.

	ENGINE
1	General
2	Cylinder block
4	Crankshaft and main bearings
8	Flywheel assembly
11	Camshaft
12	Tappets
13	Connecting rods and pistons
16	Cylinder head
17	Valves
18	Rocker shaft assembly
19	Operation
20	Rocker cover
21	Timing case and timing gear
	ENGINE LUBRICATION
23	General
25	Oil circulation
26	Oil pump
27	Oil cooling
28	Oil filter

Fig.

	Page	
1	3.5 Litre petrol engine	2
2	Crankshaft	3
3	Flywheel assembly	4
4	Camshaft and chainwheel	5
5	Tappets	6
6	Piston and connecting rod	7
7	Exploded view of cylinder head	8
8	Timing chain, chainwheels, cover and water pump	11
9	Engine oil circulation	13
10	Oil pump	15



The engine shown is a 12/24V screened engine with power steering pump.

Fig 1 3.5 Litre petrol engine

ENGINE

General

1 The engine (Fig 1) is a Land Rover 3.5 litre, overhead valve unit having two rows of four cylinders in a vee configuration and liquid cooling. The engine has a nominal bore of 88.90 mm (3.50 in) and a stroke of 71.12 mm (2.80 in) giving a cubic capacity of 3528 cubic centimetres (215 cu.in.)

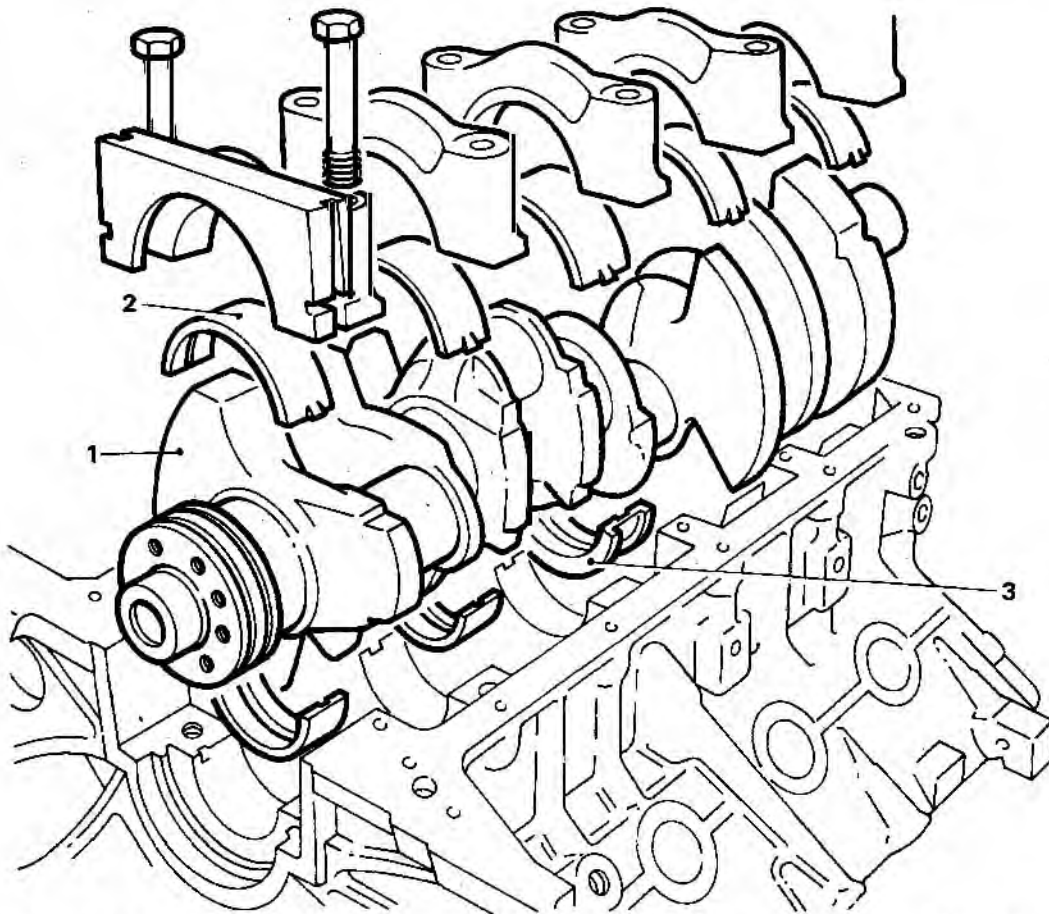
Cylinder block

2 The cylinder block is of aluminium alloy and is cast integrally with a shallow crankcase. The two banks of cylinders form a 90° angle.

3 The cylinder bores have pressed in liners which may be re-bored at overhaul intervals if necessary.

Crankshaft and main bearings

4 The crankshaft (Fig 2 (1)) runs in five sets of pre-finished replaceable shell bearings (2).



1 Crankshaft
2 Shell bearing

3 Centre shell bearing
upper half

Fig 2 Crankshaft

5 The end float on the crankshaft is controlled by the centre main bearing upper half (3) which is a flanged bearing presenting a thrust face on either side to the crankshaft. The cap half of the bearing is a plain shell type.

6 The front end of the crankshaft has a pulley fitted which incorporates a torsional vibration damper.

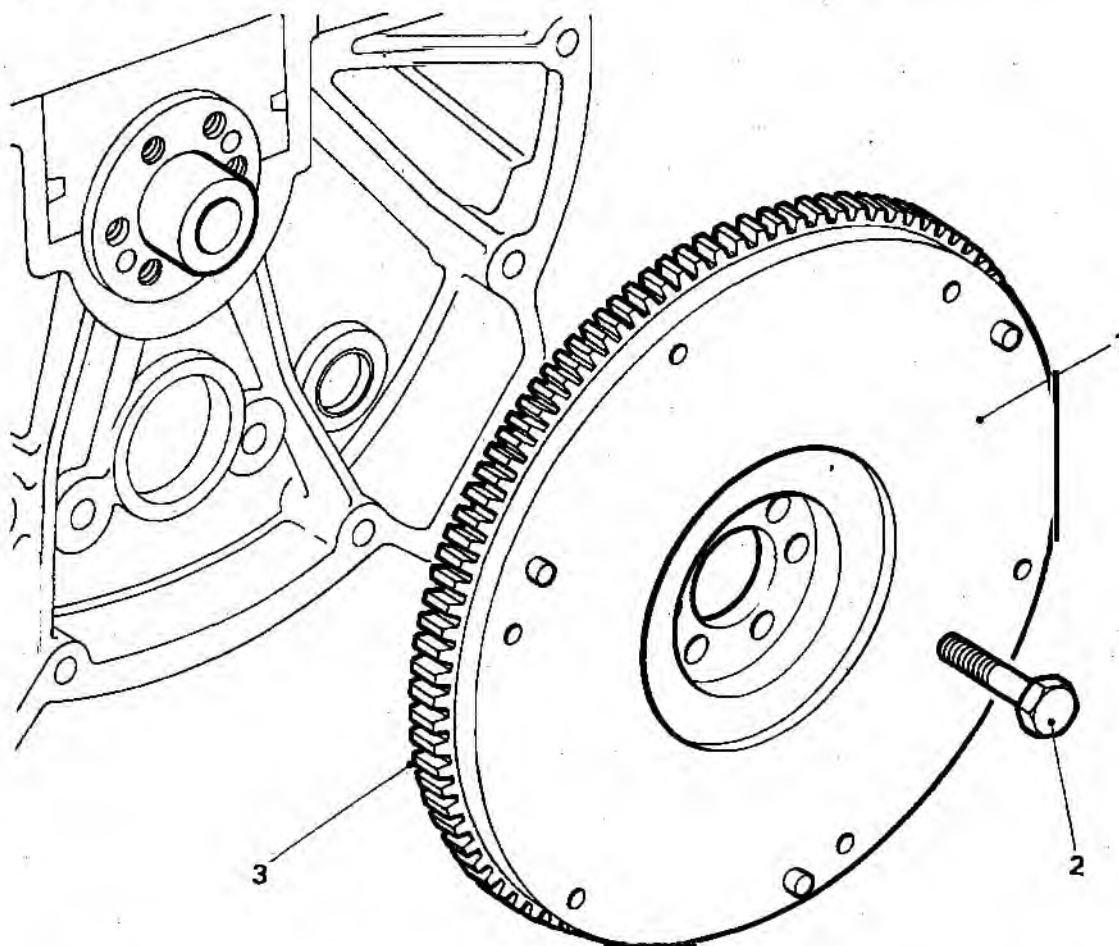
7 The crankshaft at the drive end has provision for six screws for attaching the flywheel.

Flywheel assembly

8 The flywheel assembly (Fig 3) consists of the flywheel and a starter ring gear.

9 The flywheel (1) is a steel forging and is located on the crankshaft by a spigot and is retained by six setscrews (2).

10 The starter ring gear (3) is shrunk on to the flywheel. The ring is heated to 170°C (338°F) prior to assembly and is slipped over the flywheel.



1 Flywheel
2 Setscrew

3 Starter ring gear

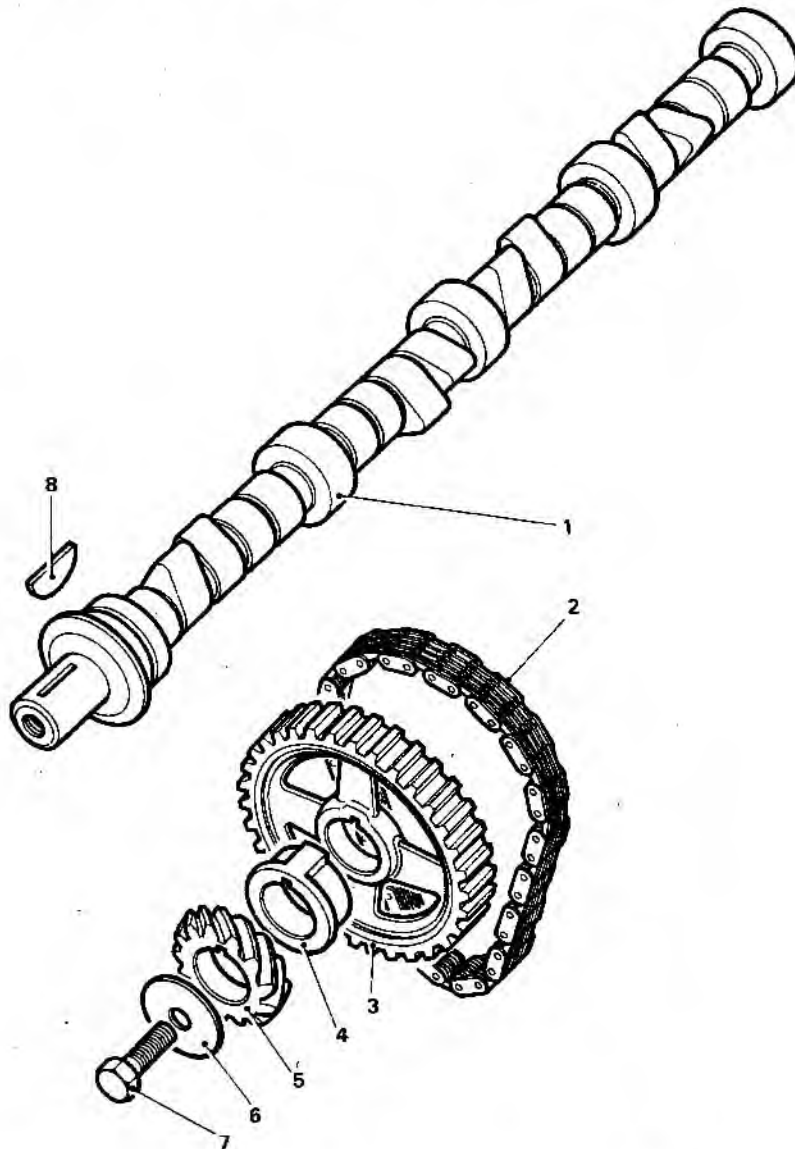
Fig 3 Flywheel assembly

Camshaft

11 The camshaft (Fig 4(1)) is located between the two banks of cylinders and is supported by five bearings which are machined in the crankcase casting. It is driven by the crankshaft via a timing chain (2) and chainwheel (3).

Note ...

The camshaft bearings are not replaceable, therefore if worn a new engine block is required.

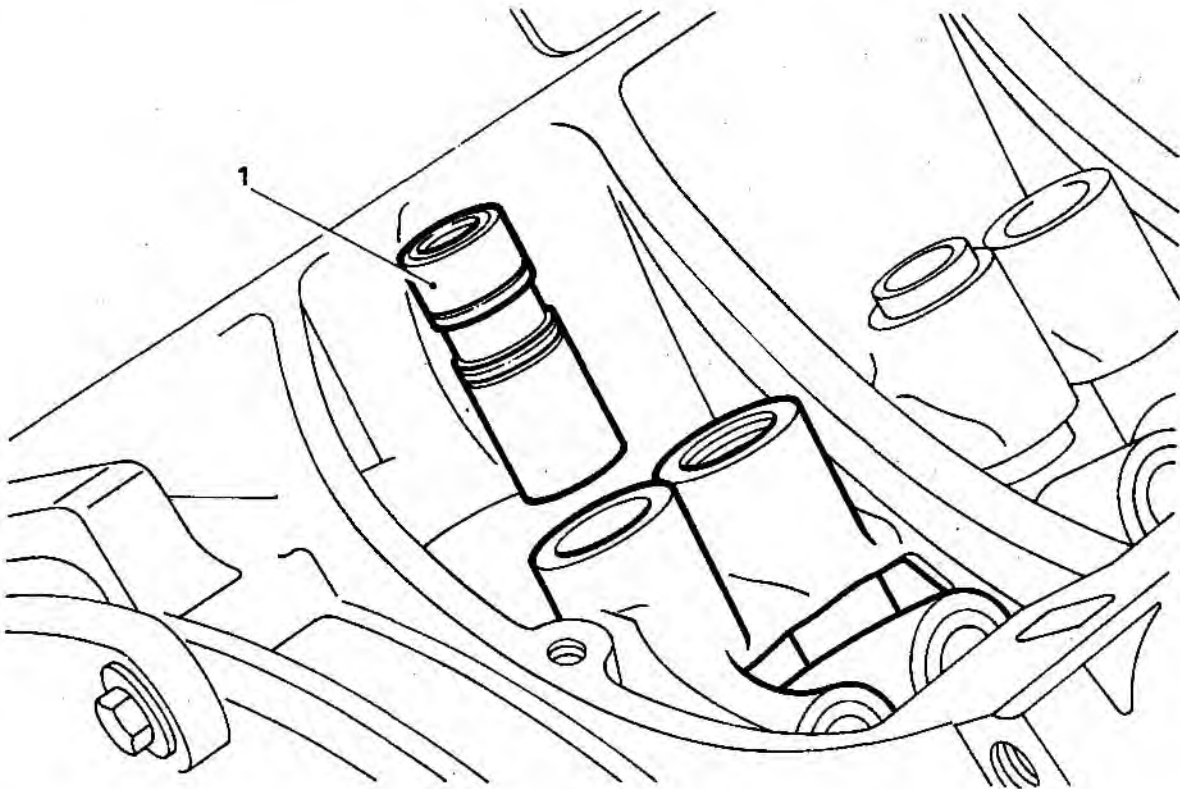


- | | | | |
|---|--------------|---|--------------|
| 1 | Camshaft | 5 | Gear |
| 2 | Timing chain | 6 | Washer |
| 3 | Chainwheel | 7 | Bolt |
| 4 | Spacer | 8 | Camshaft Key |

Fig 4 Camshaft and chainwheel

Tappets

12 The tappets (Fig 5 (1)) are of the hydraulic type which ensure quiet running and obviates the need for adjustment.



1 Hydraulic tappets

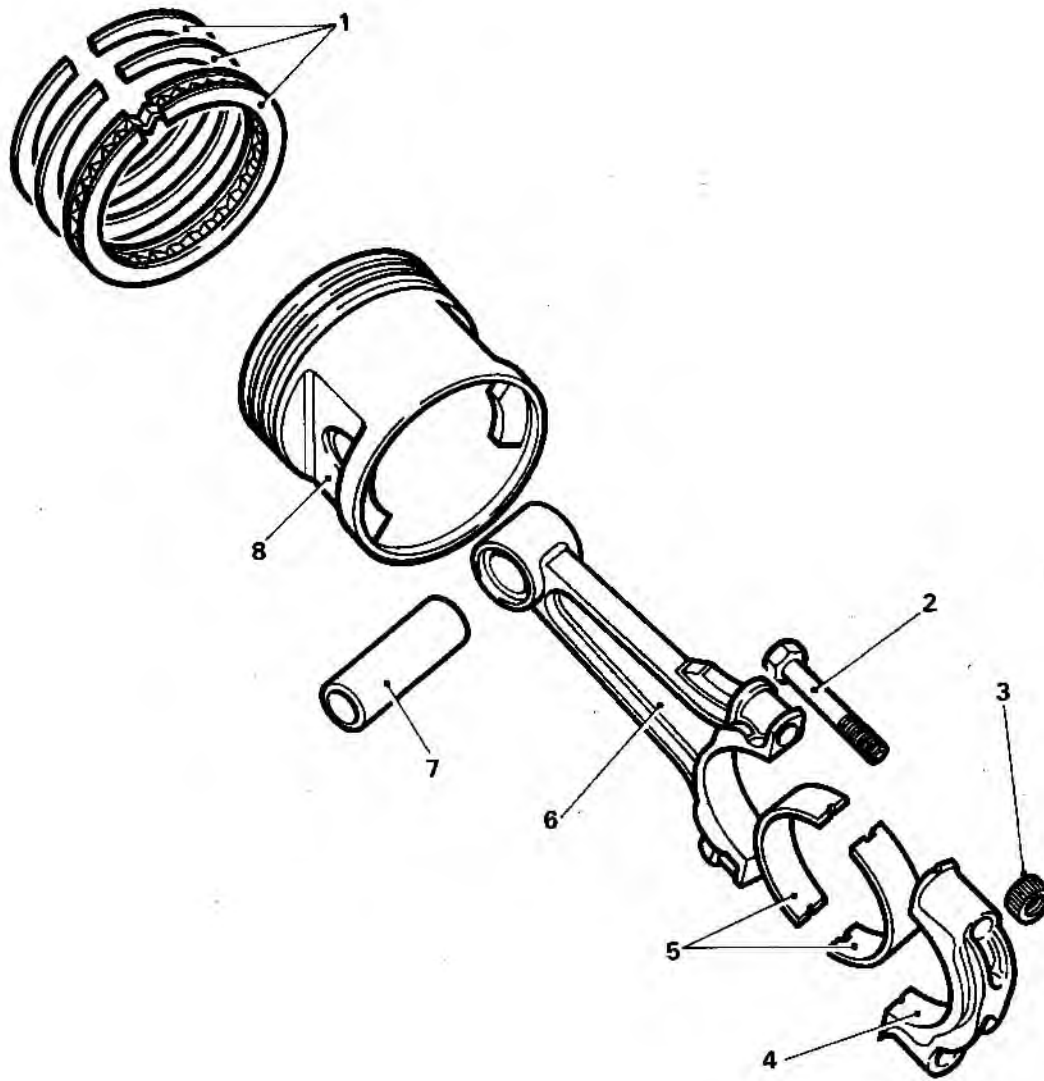
Fig 5 Tappets

Connecting-rods and pistons

13 A connecting rod and piston assembly is shown in Fig 6. Shell bearings (5) are fitted to the big ends of the connecting rods (6). The pistons (8), connecting rods (6), bearing caps (4), and gudgeon pins (5) should be labelled to ensure that they are replaced in the same cylinders from which they were removed.

14 The pistons (8) are fitted to the connecting rods (6) by gudgeon pins (7). The connecting rod bearing caps (4) are retained by two special bolts (2) and nuts (3).

15 Each piston has three rings (1) fitted comprising of a chromed compression ring at the top, a plain compression ring marked 'top' on its upper surface and a three part oil scraper ring which consists of an expansion ring and two ring rails.



- 1 Piston rings
- 2 Bolt
- 3 Nut
- 4 Bearing cap

- 5 Shell bearings
- 6 Connecting-rod
- 7 Gudgeon pin
- 8 Piston

Fig 6 Piston and connecting rod

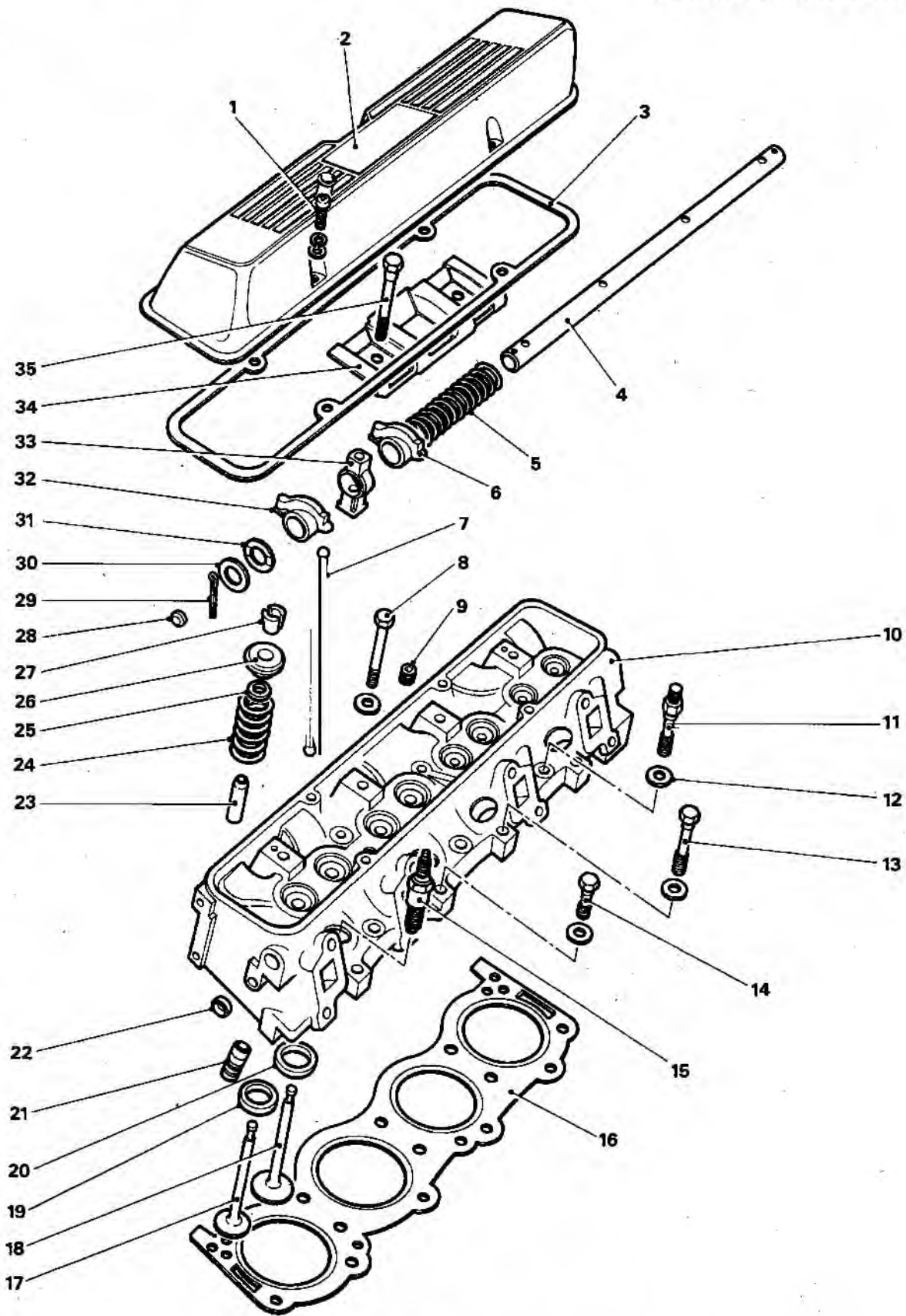


Fig 7 Exploded view of cylinder head

Key to fig 7

1 Bolt	19 Exhaust valve seat
2 Rocker cover	20 Inlet valve seat
3 Gasket	21 Hydraulic tappet
4 Shaft	22 Cup plug
5 Spring	23 Valve guide
6 Rocker assembly R.H.	24 Valve spring
7 Push rod	25 Valve stem seal
8 Bolt	26 Valve spring cap
9 Core plug	27 Split collets
10 Cylinder head	28 Shaft end plug
11 Bolt	29 Split pin
12 Washer	30 Plain washer
13 Bolt	31 Wave washer
14 Bolt	32 Rocker assembly L.H.
15 Spark plug	33 Bracket
16 Gasket	34 Baffle
17 Exhaust valve	35 Bolt
18 Inlet valve	

Cylinder heads

16 The two cylinder heads (Fig 7 (10)) are of a similar construction being cast in aluminium alloy and having both the inlet and exhaust valve guides (23) and seats (19,20) inserted. The valves are arranged in line and are inclined at an angle of 10° above the cylinder bore centre line. The cylinder heads have cast water channels for the circulation of coolant.

Valves

17 The valve assembly consists of a valve (17), valve spring (24), spring retainer (26) and two collets (27). In addition there is a seal (25) fitted to each of the inlet valve stems.

Rocker shaft assembly

18 The rocker shaft assembly consists of a tubular rocker shaft (4) with pivoting rocker arms (6,32). Springs (5) are positioned between the rocker arms on the rocker shaft which is supported by four brackets (33) attaching the assembly to the cylinder head via through bolts (35).

Operation

19 The valves are operated at timed intervals by the camshaft. As a cam lobe rotates, it pushes the tappet which in turn moves the pushrod. The pushrod is engaged in a recess in one end of the rocker. The opposite end of the rocker applies pressure to the end of the valve stem overcoming the opposing force which the valve spring is applying thus opening the valve. When the cam lobe has rotated away from the tappet, the valve spring closes the valve returning the mechanism to its original position.

Rocker cover

20 The rocker covers are retained by four bolts and they are each fitted with a replaceable gasket. The left-hand rocker box is fitted with a breather and the right-hand with an oil filler.

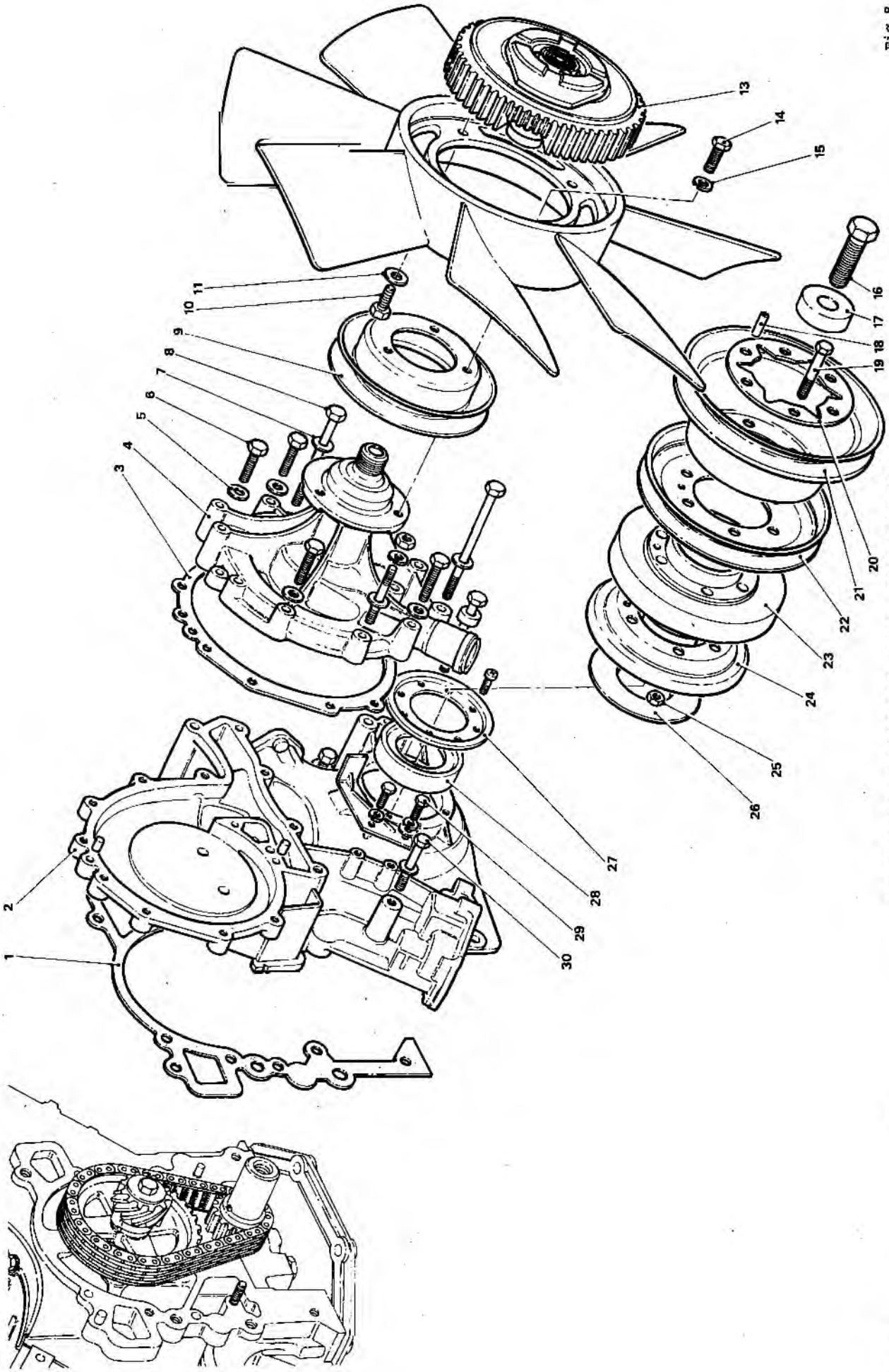
Timing case and timing gear

21 The timing case (Fig 8) is an aluminium alloy casting which houses the timing chain, chain wheels, the distributor drive gear and a crankshaft oil seal (28). Mounted on the outside of the timing case are the oil pump housing, the distributor and the coolant pump (4). The whole assembly is located on the front of the crankcase where it is retained by bolts and is sealed by a gasket (1).

22 The length of crankshaft which projects through the timing case has double pulley (21 & 22) on 12V vehicles or a treble pulley on 12/24V vehicles from which run vee-belts to drive the alternator(s), the cooling fan, coolant pump and the power steering pump (where fitted). Timing marks are engraved on the pulley to facilitate timing of the engine.

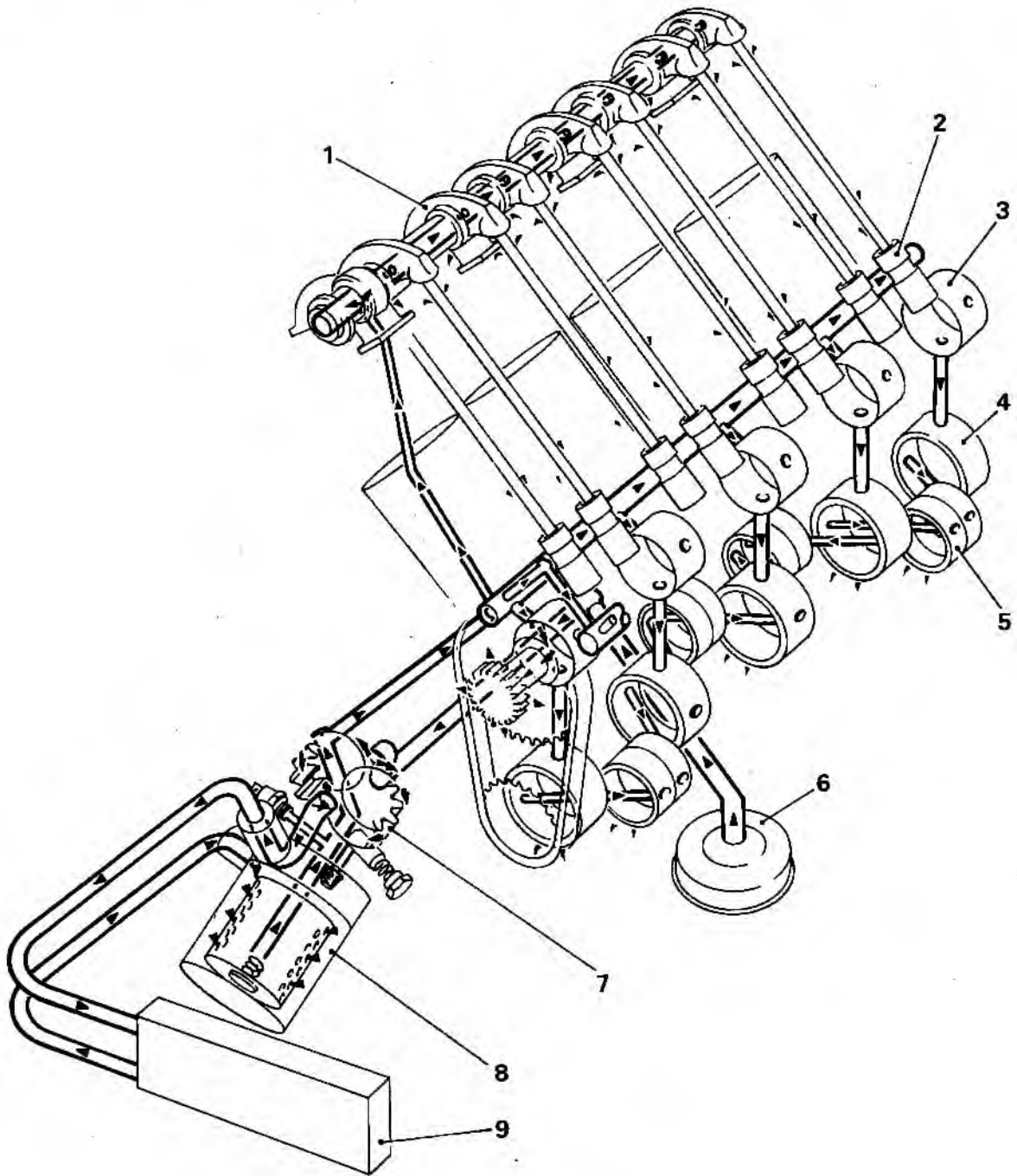
Key to fig 8

1	Gasket	16	Setscrew
2	Timing cover	17	Spacer
3	Gasket	18	Pin
4	Water pump	19	Bolt
5	Plain washer	20	Reinforcing plate
6	Setscrew	21	Pulley
7	Plain washer	22	Pulley
8	Bolt	23	Vibration damper
9	Pulley	24	Balance rim
10	Setscrew	25	Nut
11	Plain washer	26	Deflector
12	Cooling Fan	27	Seal retainer
13	Viscous coupling	28	Seal
14	Setscrew	29	Bolt
15	Spring washer	30	Bolt



Timing chain, chainwheels, cover and water pump





- | | | | |
|---|--------------------------|---|--------------|
| 1 | Rocker arms | 6 | Oil strainer |
| 2 | Tappets | 7 | Oil pump |
| 3 | Camshaft bearings | 8 | Oil filter |
| 4 | Crankshaft main bearings | 9 | Oil cooler |
| 5 | Connecting-rod bearings | | |

Fig 9 Engine oil circulation

ENGINE LUBRICATIONGeneral

23 The engine is lubricated by a wet sump system, the oil being circulated by a gear type pump driven by a skew gear on the camshaft.

Oil circulation (Fig 9)

24 The oil pump draws oil up from the sump through a suction pipe and strainer from where it passes through drillings in the cylinder block to an external full-flow filter. An oil cooler is fitted to prevent overheating during prolonged running of the engine whilst the vehicle is stationary.

Note ...

In Fig 9 only one bank of cylinders is shown for clarity.

25 Oil lubricates the big end bearings by passing through the crankshaft webs via drilling in the cylinder block and crankshaft main bearings. Lubrication to the rockers and valve gear is provided by oil passing through branches from the main gallery via the two cylinder heads. The oil then drains down the pushrod tunnels to lubricate the camshaft lobes returning to the sump.

Oil pump

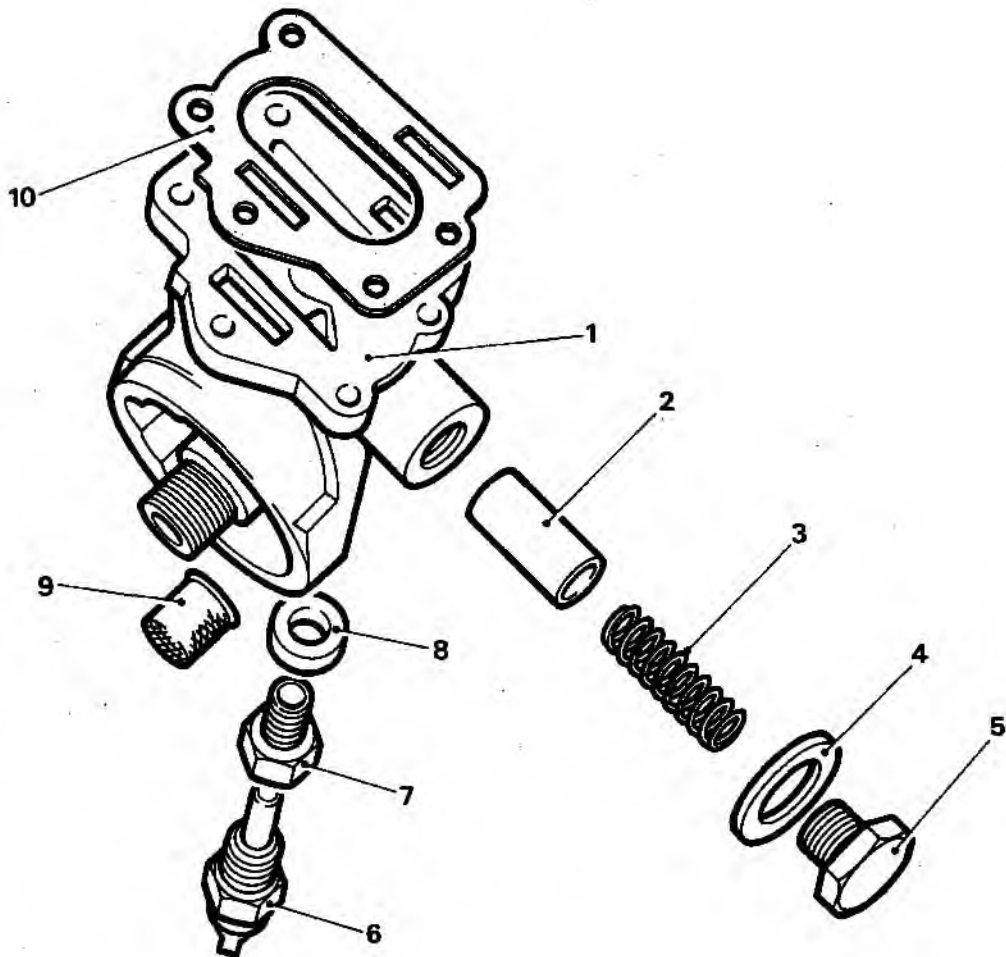
26 The oil pump (Fig 10) is a gear type which is driven via a skew gear fitted to the camshaft. The upper end of the shaft driven by the skew gear drives the distributor. Oil pressure is affected by changes in engine speed and therefore is excess oil pressure is controlled by a pressure relief valve (2) which opens allowing oil to recirculate to the low pressure side of the pump.

Oil cooling

27 After passing through the oil pump, oil transfers through a hose which is connected to the filter housing, to an oil cooler which is mounted at the front of the vehicle. A return hose then feeds the oil back into the filter housing where it passes into the oil filter.

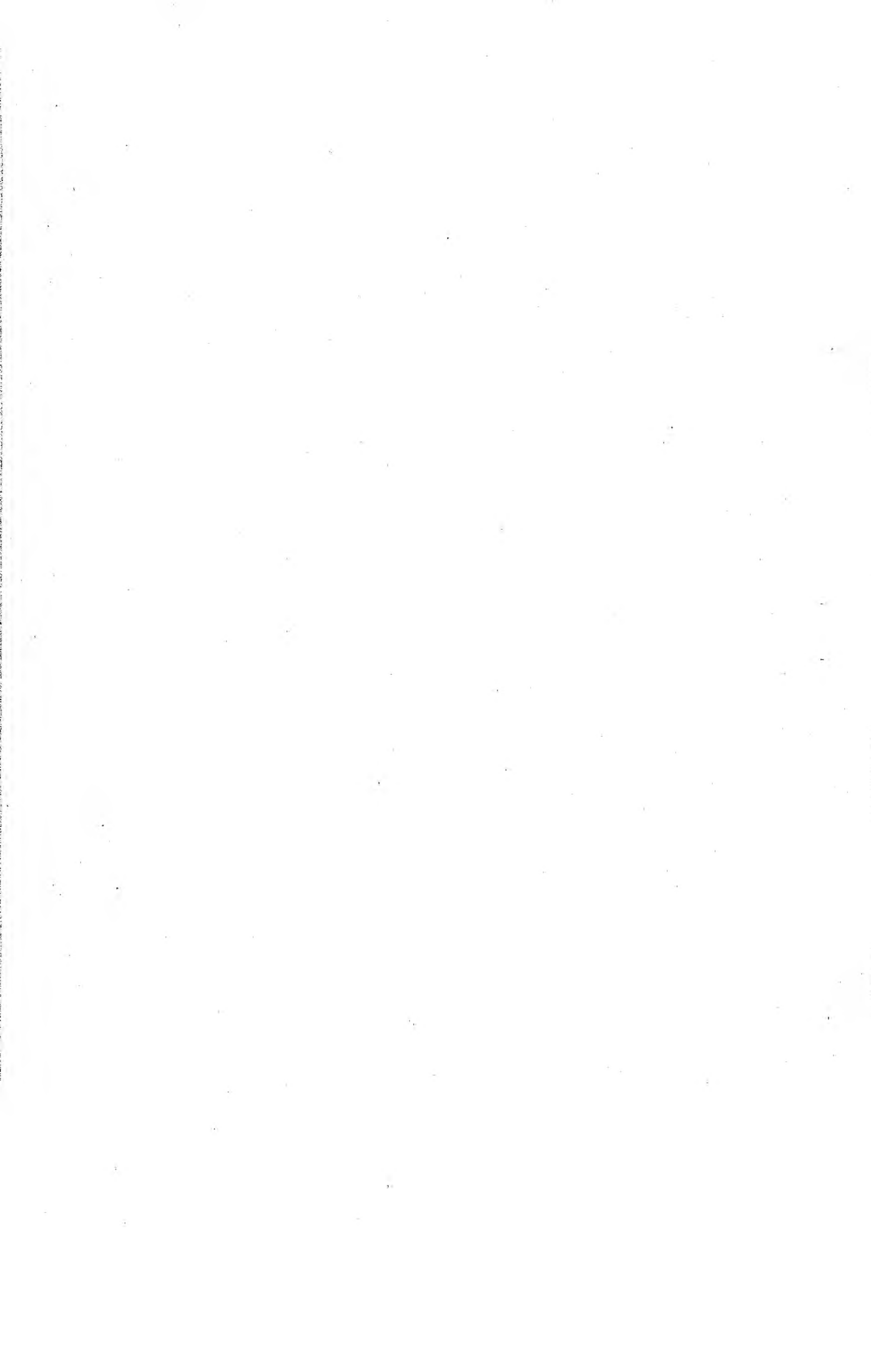
Oil filter

28 The oil filter is of the full flow type containing a replaceable cartridge with paper element. Should the element become obstructed, a bypass valve in the filter will still allow oil to circulate around the engine.



- | | | | |
|---|---------------|----|--------------------|
| 1 | Oil pump body | 6 | Temperature sender |
| 2 | Relief valve | 7 | Adaptor |
| 3 | Spring | 8 | Joint washer |
| 4 | Joint washer | 9 | Strainer |
| 5 | Cap | 10 | Gasket |

Fig 10 Oil pump



Chapter 1-3

2.5 LITRE DIESEL ENGINE BREATHER SYSTEM

TECHNICAL DESCRIPTION

CONTENTS

Frame	Para		Page
	1	Introduction	
	2	Description	
	4	Cyclone unit	
	5	Depression regulator	
	6	Operation	
	Fig		
	1	2.5 Litre diesel engine breather system	2

INTRODUCTION

1 This chapter details the technical description for the 2.5 litre diesel engine breather system fitted to Land Rover 90 and 110 vehicles.

Description

2 Normal engine respiration takes place through the transfer of air from the cylinder head to the induction manifold via a series of braided hoses, an in-line cyclone unit and a depression regulator.

3 A filler/breather cap (Fig 1 (1)) is fitted to the rocker cover to which a hose (2) is connected leading to an inlet port on the side of the cyclone unit (5). One of two outlet ports on the cyclone unit is connected by hose (7) to an inlet located in the engine sump. A hose (4) connected to the second outlet port leads to the underside of the depression regulator (3). A final hose (8) is connected between the outlet of the depression regulator and the induction manifold (9).

Cyclone unit

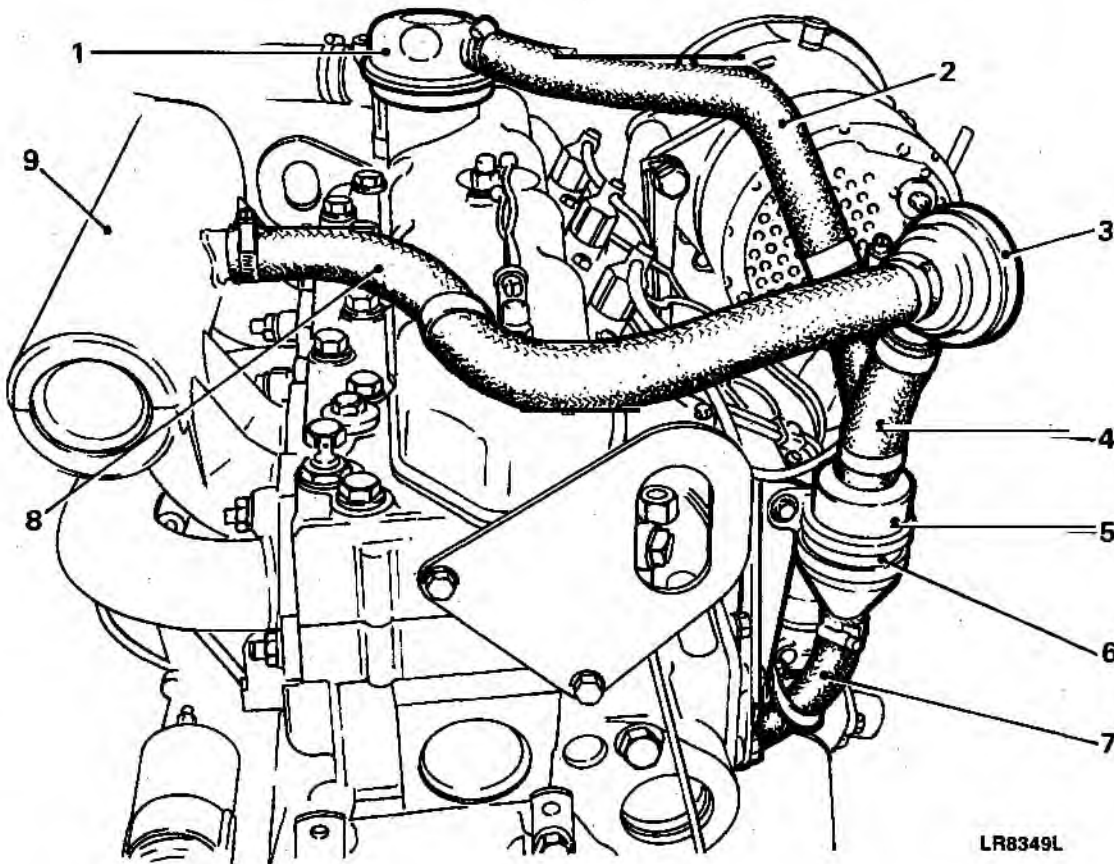
4 The cyclone unit consists of a hollow cylindrical chamber. Oil contaminated air vapour enters through the side inlet port of the unit and swirls around the chamber inside diameter causing a central low pressure. The oil then separates from the vapour allowing clean air to rise through the top outlet port.

Depression regulator

5 The depression regulator consists of housing fitted with an internal diaphragm and spring. The component is designed to regulate crankcase air pressure and to prevent oil contaminated air vapour entering the inlet manifold through the effect of excess depression.

Operation

6 Pressure decrement originated in the induction manifold and governed by the depression regulator provides the specific suction necessary for gas to be drawn from the cylinder head and through the breather system. Oil vapour contaminated air is drawn through the rocker cover filler/breather cap to the cyclone unit where a swirling action separates the engine oil from the air. Extracted oil is allowed to gravity feed back to the engine sump. Clean air then rises from the cyclone unit, through the depression regulator and into the induction manifold.



LR8349L

- | | |
|--------------------------------|---------------------------|
| 1 Filler/breather cap | 6 Support bracket |
| 2 Cyclone unit inlet hose | 7 Oil return to sump hose |
| 3 Depression regulator | 8 Induction inlet hose |
| 4 Cyclone unit air outlet hose | 9 Induction manifold |
| 5 Cyclone unit | |

Fig 1 2.5 litre diesel engine breather system

Chapter 2

CLUTCHES

TECHNICAL DESCRIPTION

INTRODUCTION

1 This Chapter gives the technical description for clutches fitted to Land Rover 2.5 litre diesel 90 and 110 vehicles, and Land Rover 3.5 litre petrol 110 and 127 vehicles.

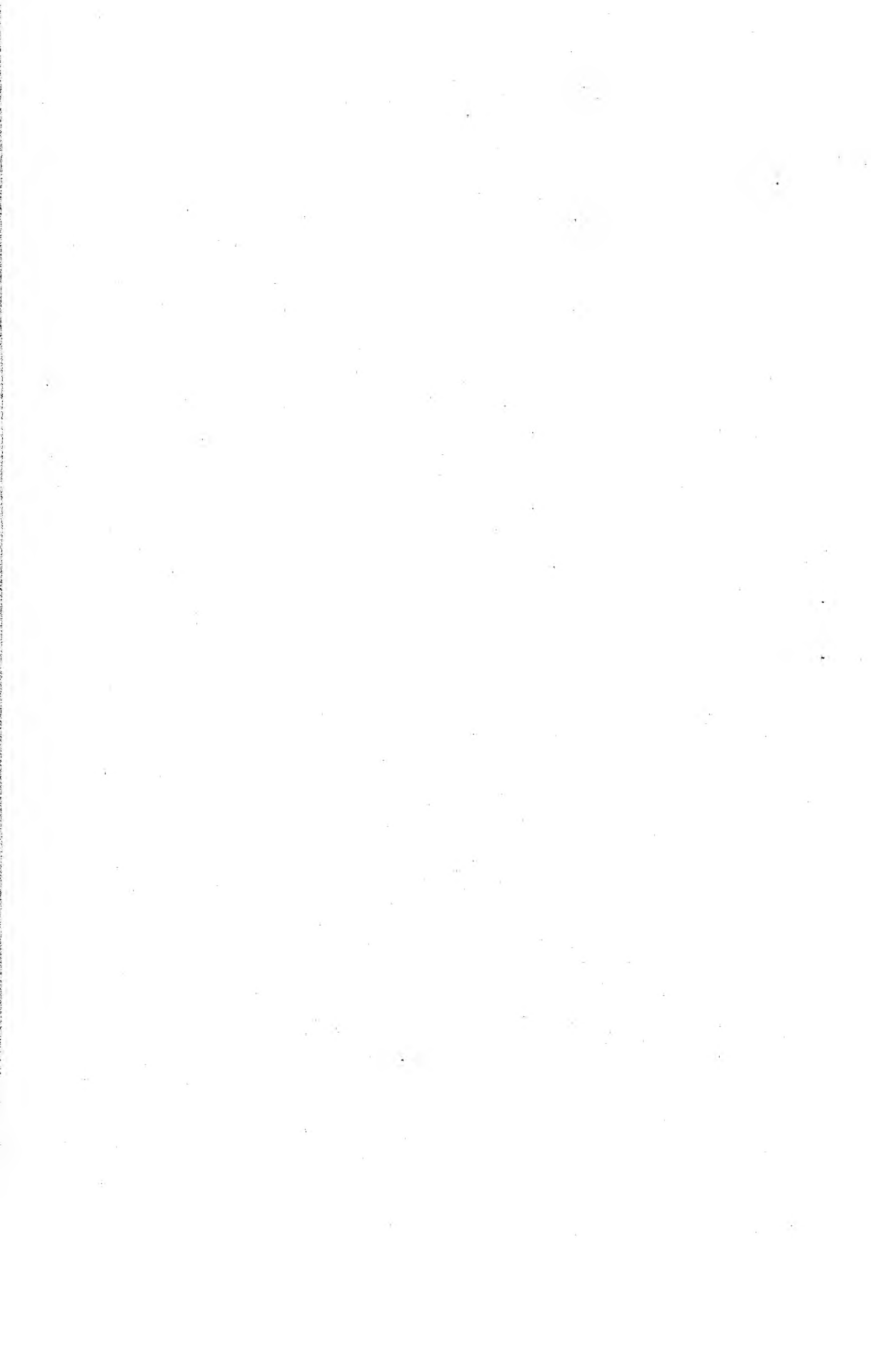
2 The Chapter has been Sub-chaptered as follows to accommodate the clutch fitted to Land Rover 2.5 litre diesel 90 and 110 vehicles, and the clutch fitted to Land Rover 3.5 litre petrol 110 and 127 vehicles.

Chapter 2-1 CLUTCH 2.5 LITRE DIESEL 90 AND 110

Chapter 2-2 CLUTCH 3.5 LITRE PETROL 110 AND 127

General

3 The information given is applicable to both left and right hand drive vehicles.



Chapter 2-1
CLUTCH 2.5 litre diesel 90 and 110

Frame Para

- 1 Introduction
- 2 Description
- 3 Operation

Fig

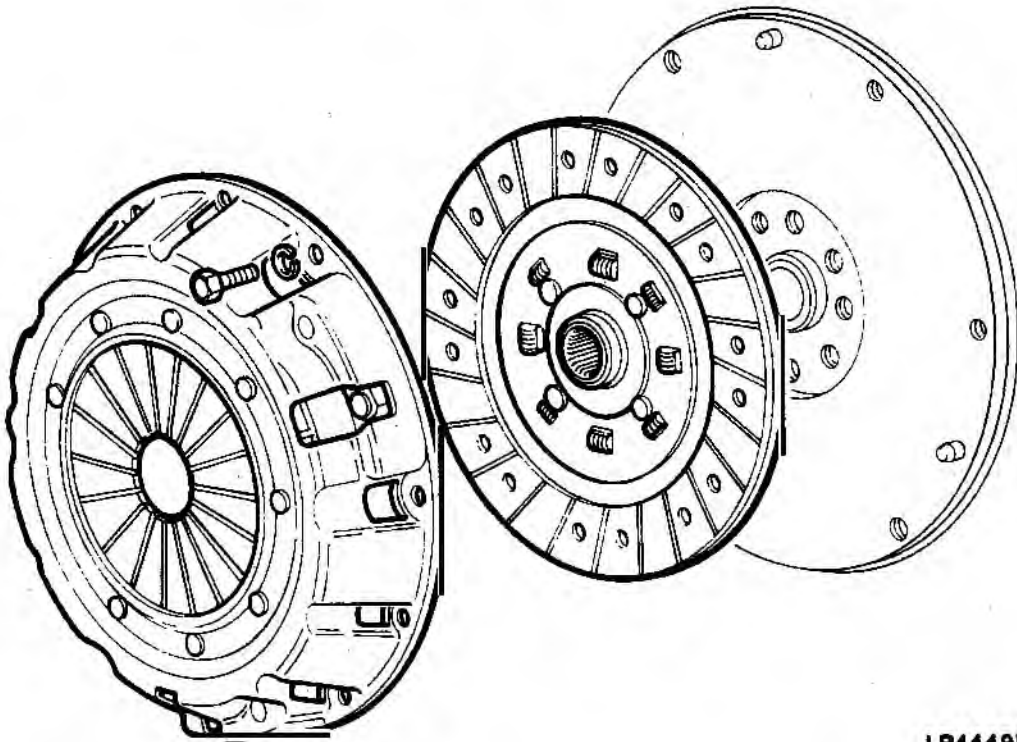
- 1 Clutch assembly
- 2 Clutch release mechanism

Page

- 1
- 2

INTRODUCTION

1 This chapter gives the technical description of the clutch and its operating mechanism as fitted to Land Rover 90 and 110 vehicles having 2.5 litre non-turbo diesel engines.



LR4449M

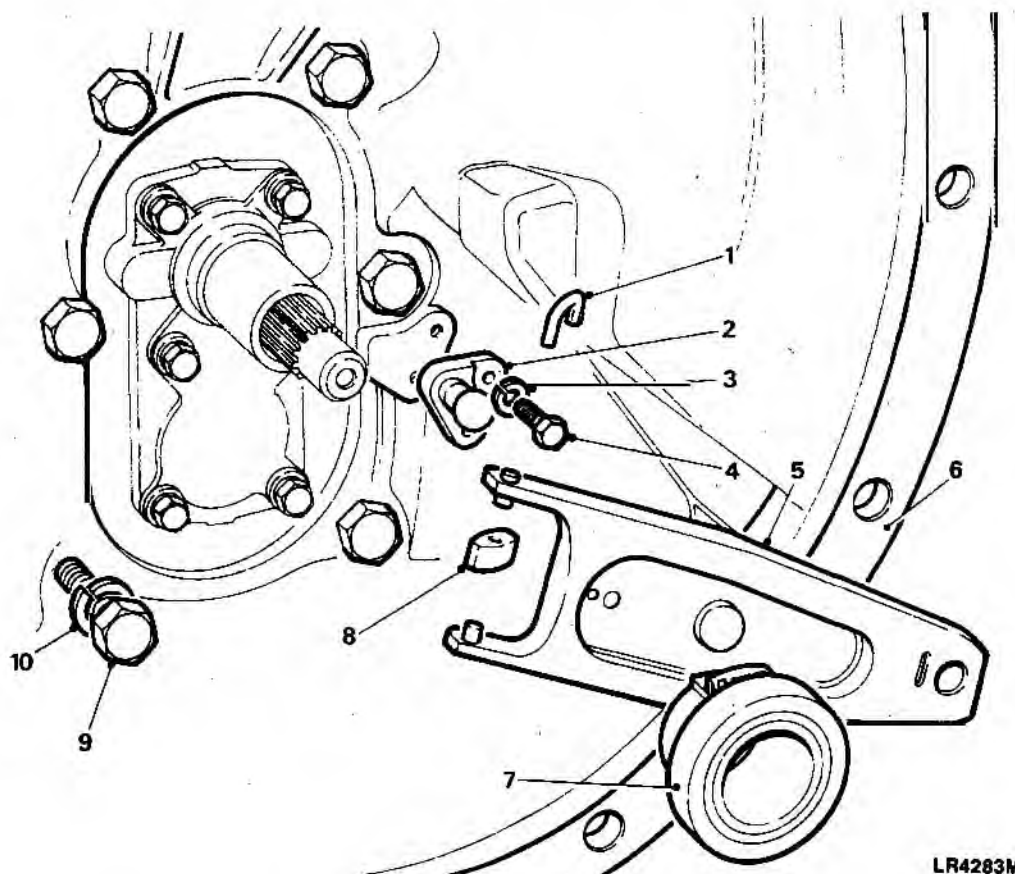
Fig 1 Clutch assembly

Description

2 The clutch is a single dry plate type with a diaphragm spring pressure plate assembly. The release mechanism is hydraulically operated through a master cylinder, mounted on the engine compartment bulkhead, and a slave cylinder secured to the bell housing. The release bearing is carried on a support sleeve on the gearbox front face and is actuated by a forked release lever which pivots on a ball type pivot post attached to the bell housing. The bearing is a pre-lubricated sealed unit and therefore requires no maintenance.

Operation

3 When the clutch pedal is depressed, fluid is forced from the master cylinder into the associated pipes and on to the slave cylinder. Fluid pressure actuates the piston in the slave cylinder causing the forked release lever to disengage the clutch.



- | | | | |
|---|----------------------|----|-----------------------------|
| 1 | Bearing carrier clip | 6 | Bell housing |
| 2 | Lever pivot | 7 | Release bearing and carrier |
| 3 | Spring washer | 8 | Slipper pad |
| 4 | Bolt | 9 | Bolt |
| 5 | Clutch release lever | 10 | Spring washer |

Fig 2 Clutch release mechanism

Chapter 2-2

CLUTCH 3.5 LITRE PETROL 110 AND 127

TECHNICAL DESCRIPTION

CONTENTS

Para.

CLUTCH

- 1 General
- 2 Fluid reservoir
- 3 Master cylinder
- 4 Slave cylinder
- 5 Release assembly
- 6 Driven plate and cover assembly

CLUTCH

General

1 The clutch is a Borg and Beck type with a single dry plate and diaphragm spring cover, hydraulically operated from a pedal actuated master cylinder and a slave cylinder at the gearbox.

Fluid reservoir

2 The reserve clutch fluid is stored in the central compartment of a dual reservoir, that is secured to the dash, adjacent to the instrument panel. (The outer compartment of the reservoir contains the reserve fluid for one section of the dual braking system).

Master cylinder

3 The outlet pipe from the bottom of the fluid reservoir is connected to a 15,87mm (0.625in) diameter bore, Girling 'CV' type master cylinder that is secured to the clutch pedal box immediately below the instrument panel.

Slave cylinder

4 The outlet pipe from the clutch master cylinder leads to the clutch slave cylinder mounted on the flange of the gearbox bell housing.

Release assembly

5 The slave cylinder push rod acts on one end of a pivoted release lever inside the bell housing, the other end of the release lever engages with a bearing and sleeve assembly that is a slide fit on the primary shaft.

Driven plate and cover assembly

6 The clutch driven plate is a slide fit on the splined end of the primary shaft, and is of the spring type pattern in which the splined hub is indirectly attached to a disc that bears two friction lining faces. Clutch engagement is maintained by a diaphragm type spring that clamps the driven plate between the clutch cover assembly and the engine flywheel. When the clutch pedal is depressed, pressure is transmitted via the master cylinder, slave cylinder and release assembly to the diaphragm spring in the clutch cover. This causes the spring to deflect and release the pressure on the driven plate, thereby disengaging the clutch.

Chapter 3

GEARBOXES

TECHNICAL DESCRIPTION

INTRODUCTION

1 This Chapter gives the technical description for gearboxes fitted to Land Rover 2.5 litre diesel 90 and 110 vehicles, and Land Rover 3.5 litre petrol 110 and 127 vehicles.

2 The Chapter has been Sub-chaptered as follows to accommodate the gearbox fitted to Land Rover 2.5 litre diesel 90 and 110 vehicles, and the gearboxes fitted to Land Rover 3.5 litre petrol 110 and 127 vehicles.

Chapter 3-1 LT77 FIVE SPEED MANUAL GEARBOX

Chapter 3-2 LT85 PUMPED FIVE SPEED MANUAL GEARBOX

Chapter 3-3 LT85 LIGHTWEIGHT DIVIDED-CASE MANUAL GEARBOX



Chapter 3-1

LT77 FIVE SPEED MANUAL GEARBOX

CONTENTS

Frame	Para		Page
	1	Introduction	
	2	General	
	10	Gear change lever	
	12	Casings	
	13	Lubrication and ventilation	
	Fig		
	1	LT77 Five speed manual gearbox	2

INTRODUCTION

1 This chapter covers the Technical Description for the LT77 Five Speed Gearbox as fitted to Land Rover 90 and 110 vehicles.

General

Note ...

Gearboxes fitted to MOD Land Rover 90 and 110 vehicles are fitted with special low ratio first and second gears, under no circumstances should the standard first and second gears or layshaft cluster be fitted at repair or overhaul.

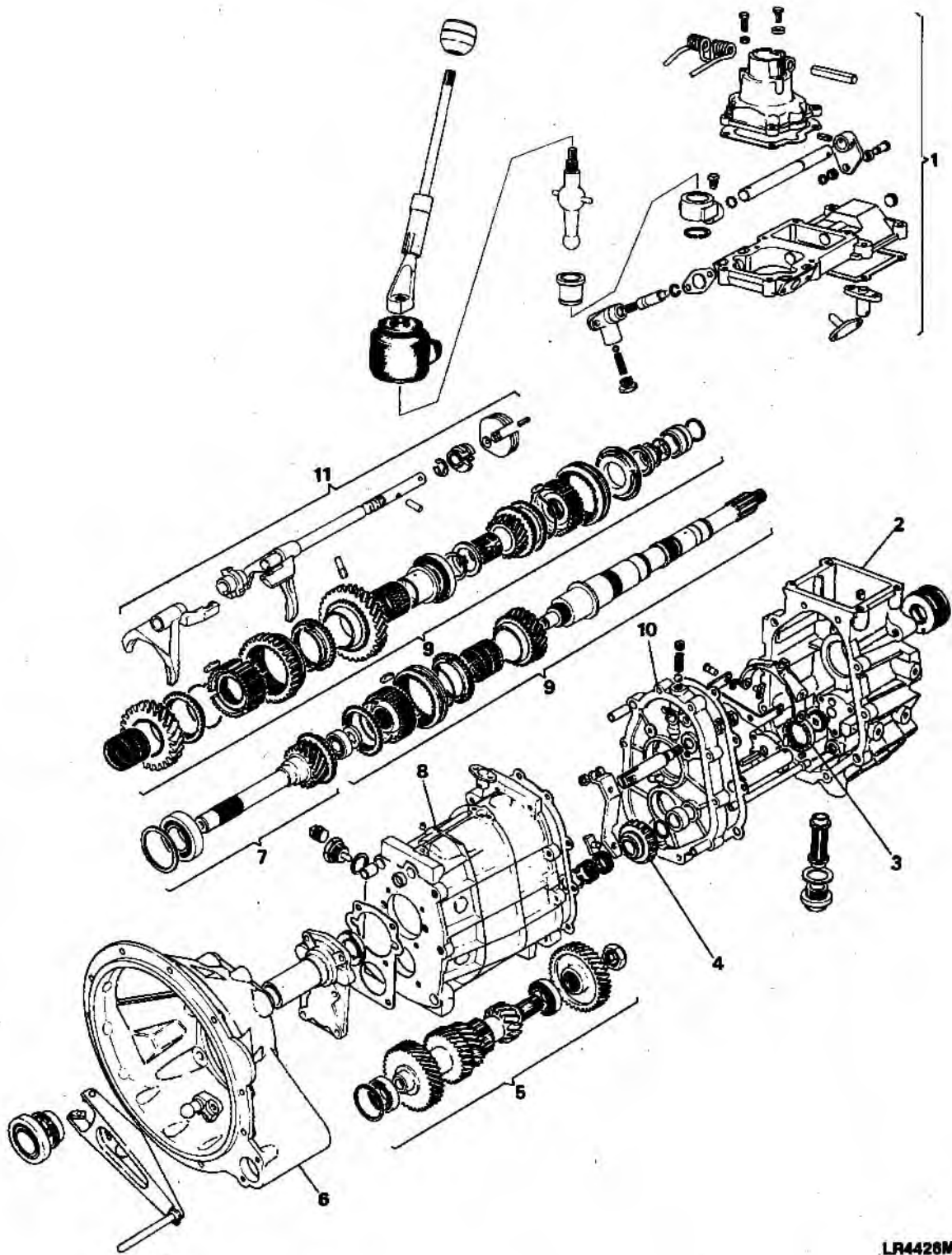
2 The gearbox has five forward speeds and one reverse with synchromesh engagement provided on all forward speeds. All forward speed gears are of the helical type and are in constant mesh.

3 Three synchronizer assemblies are installed, one between the mainshaft first and second speed gears, one between the mainshaft third and fourth speed gears and one at the rear of the mainshaft fifth speed gear.

4 The input shaft is supported by a taper roller bearing housed in the main casing. The mainshaft is supported by two taper roller bearings one housed in the rear of the input shaft and one housed in the centre plate.

5 The first, second, third and fifth mainshaft gears are supported on caged needle roller bearings whilst the synchronizer assemblies are located on splines. The main fourth speed gear is formed on the inner end of the input shaft and the mainshaft reverse gear is integral with the first and second speed synchronizer.

6 The layshaft is supported at the front end by a taper roller bearing housed in the main casing and at the rear end by a taper roller bearing housed in the centre plate. All gears are formed as an integral part of the layshaft except the fifth gear which is a separate gear splined to the layshaft and secured by a staked nut. A square drive peg fitted to the rear end of the layshaft provides the drive for the gearbox oil pump.



LR4428M

Fig 1 LT77 Five speed manual gearbox

Key to Fig 1

1	Remote gear change housing assembly	7	Primary pinion assembly
2	Extension case	8	Main gearcase
3	Oil pump assembly	9	Main shaft and gear assembly
4	Reverse idler assembly	10	Centre plate
5	Layshaft assembly	11	Gear selector assembly
6	Bell housing		

7 The reverse idler gear, which is fitted with two caged needle roller bearings retained by circlips, is mounted on a stationary shaft secured between the centre plate and the front of the main casing.

8 Engagement of the reverse idler gear with its associated gears on the main and layshafts is controlled by a lever and pivot via the gear change mechanism to the gear shift lever.

9 Forward speed gears are engaged by three shift forks attached to rods and inter-connected with the gear shift lever.

Gear change lever

10 The gear change lever is connected to a lower lever assembly supported in a housing attached to the top of the gearbox. The lower lever has a bulbous shape formed in the centre, allowing it to pivot on its seat to obtain the necessary movement required to achieve gear changing. A cross pin fitted through the bulbous portion of the lever locates in slots in the lever housing and prevents rotational movement.

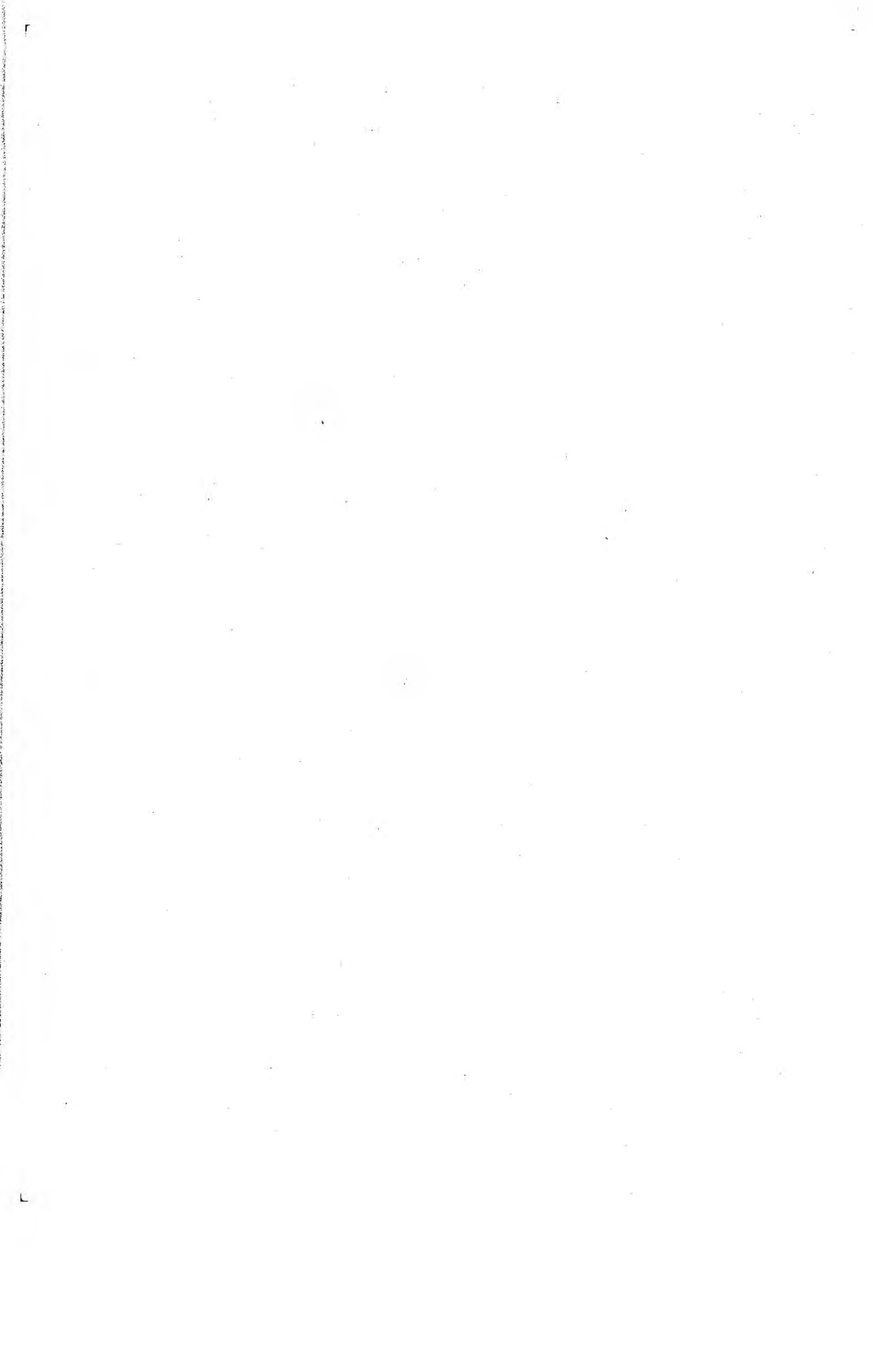
11 At the bottom of the lever a smaller bulbous shape seats in a yoke fitted to the end of the selector shaft. A quadrant attached to the other end of the shaft locates within a mating quadrant fitted to the end of the main selector shaft and fork assembly.

Casings

12 The gearbox casings consist of a main casing, a centre plate and an extension casing. The casings house the gear train mechanisms and provide housings for the bearings supporting the running shafts. The front end of the main casing carries the clutch bell housing, whilst the extension casing houses the oil circulation pump and forms the mounting for the transfer box.

Lubrication and ventilation

13 Gearbox lubrication is achieved by oil being pumped through internal drillings in the extension casing and through an oil feed ring to a central drilling in the main shaft, cross drillings in the shaft allow the oil to be fed to the needle roller bearings and the shrouded spigot bearing, with excess oil splash lubricating the gears. Ventilation is via a breather banjo situated on the side of the extension casing.



Chapter 3-2

LT85 PUMPED FIVE SPEED MANUAL GEARBOX

TECHNICAL DESCRIPTION

CONTENTS

Frame	Para		Page
	1	Introduction	
	2	General	
	10	Gear change lever	
	12	Castings	
	13	Lubrication and ventilation	
	Fig		
	1	Gear casings	3/4
	2	Gear selectors	5
	3	Gears and shafts	7/8

INTRODUCTION

1 This Chapter details the technical description for the LT85 Five speed manual gearbox fitted to Land Rover 3.5 litre petrol 127 vehicles.

GENERAL

Note ...

The gearboxes fitted to MOD Land Rover 127 vehicles are fitted with special low ratio first and second gears. Under no circumstances should standard first and second gears or lay shaft clusters be fitted during repair or overhaul procedures.

2 The gearbox has five forward speeds and one reverse with synchromesh engagement provided on all forward speeds. All forward speed gears are of the helical type and are in constant mesh.

3 Three synchronizer assemblies are installed, one between the mainshaft first and second gears, one between the mainshaft third and fourth speed gears and one at the rear of the mainshaft fifth speed gear.

4 The input shaft is supported by a plain ball journal housed in a front bearing plate. The mainshaft is supported by a plain ball journal housed in the main casing at the output end, and by a caged roller bearing fitted within the input gear on the input shaft.

5 The first, second, third and fifth mainshaft gears (Fig 3) are supported on caged needle roller bearings whilst the synchronizer assemblies are located on splines. The main fourth speed gear is formed on the inner end of the input shaft and the mainshaft reverse gear is integrated with the first and second speed synchronizer.

6 The layshaft is supported at the front end by a roller bearing in the front bearing plate. The rear end is supported by a double row of ball bearings housed in the main casing. All gears are formed as an integral part of the layshaft except the fifth gear which is a separate gear splined to the layshaft and secured by a staked nut. The layshaft rear end also has a square socket which provides a drive for the gearbox oil pump.

7 The reverse idler gear which is fitted with two caged needle roller bearings retained by circlips is mounted on a stationary shaft secured between the rear end of the main casing and a lug within the main casting.

8 Engagement of the reverse idler gear with its associated gears on the main and layshafts is controlled by a lever and pivot via the gear change mechanism to the gearshift lever.

9 Forward speed gears are engaged by three shift forks attached to rods and inter-connected with the gear shift lever (Fig 2).

Gear change lever

10 The gear change lever is connected to a lower lever assembly supported in a housing attached to the top of the gearbox (Fig 5). The lower lever has a bulbous shape formed in the centre, allowing it to pivot on its seat to obtain the necessary movement required to achieve gear changing. A cross pin fitted through the bulbous portion of the lever locates in slots in the lever housing and prevents rotational movement.

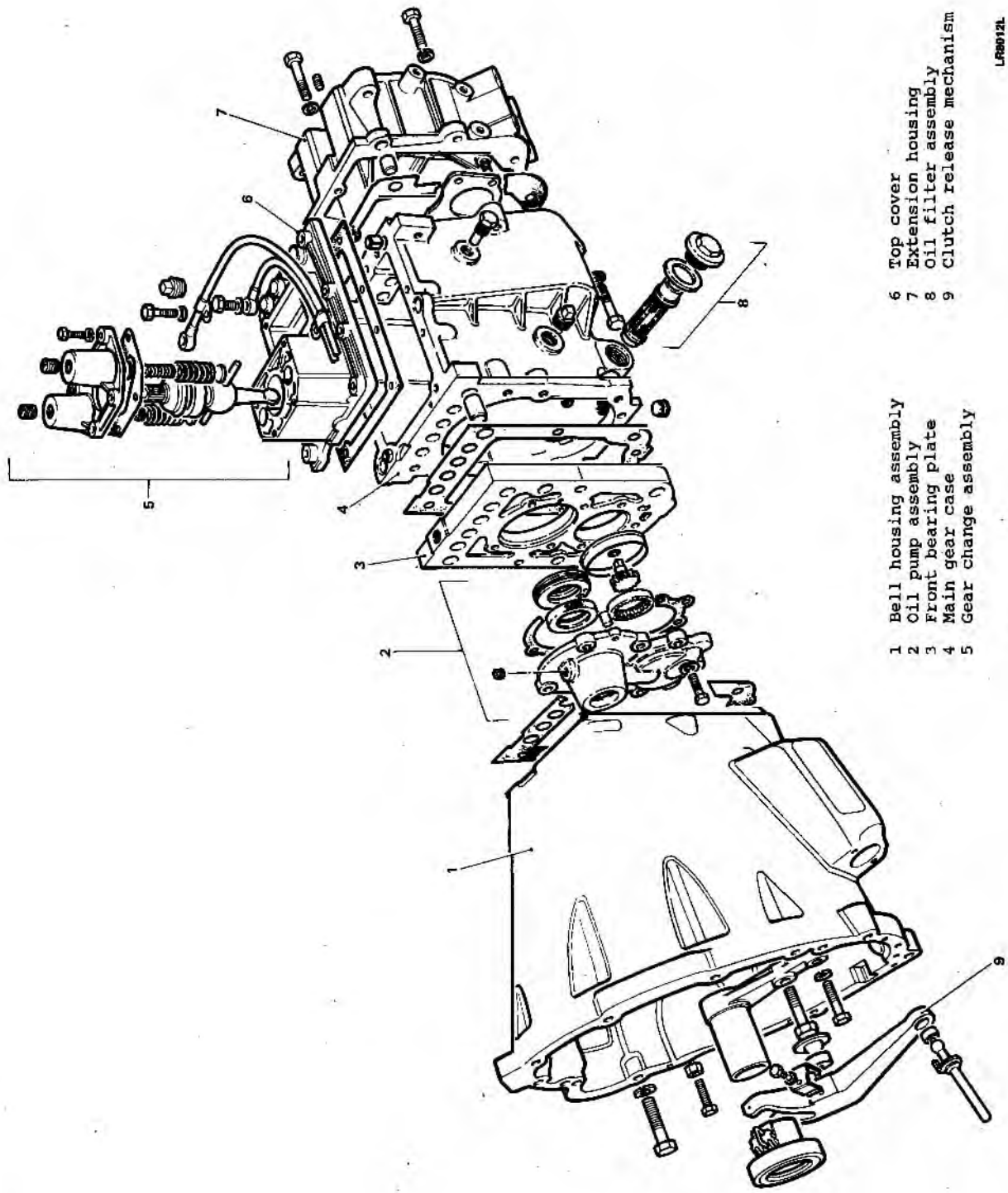
11 The bottom of the lever is a flattened ball shape which engages with one of four sets of selector jaws according to the position of the gear lever.

Casings

12 The gearbox casings (Fig 1) consist of a front bearing plate (3), a main casing (4) and an extension housing (6). The casings house the geartrain mechanisms and provide housings for the bearings supporting the running shafts. The front end of the main casing carries the front bearing plate and clutch bell housing whilst the extension housing at the rear forms the mounting for the transfer gearbox. The oil circulation pump (2) is mounted between the front bearing plate and the bell housing.

Lubrication and ventilation

13 Lubrication is achieved by oil being pumped through internal drillings in a cover mounted on the bearing plate which feeds oil to the centre of the input shaft via an oil feed ring and annular drillings in the input shaft. More cross drillings along the shaft feed oil to the needle roller bearings with excess oil splash lubricating the gears. Ventilation is via a banjo situated on the gear change lever housing.



- 1 Bell housing assembly
- 2 Oil pump assembly
- 3 Front bearing plate
- 4 Main gear case
- 5 Gear change assembly

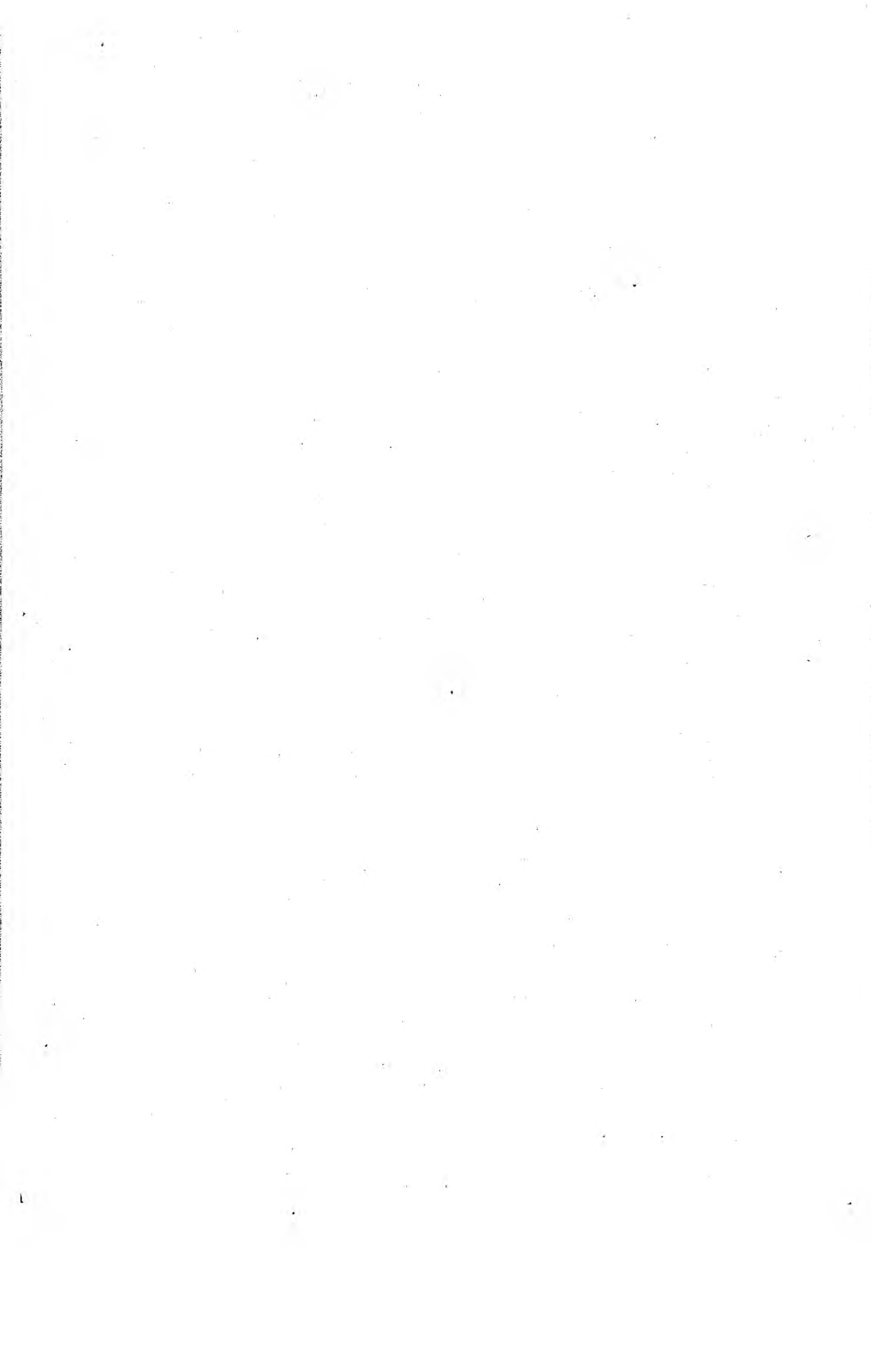
- 6 Top cover
- 7 Extension housing
- 8 Oil filter assembly
- 9 Clutch release mechanism

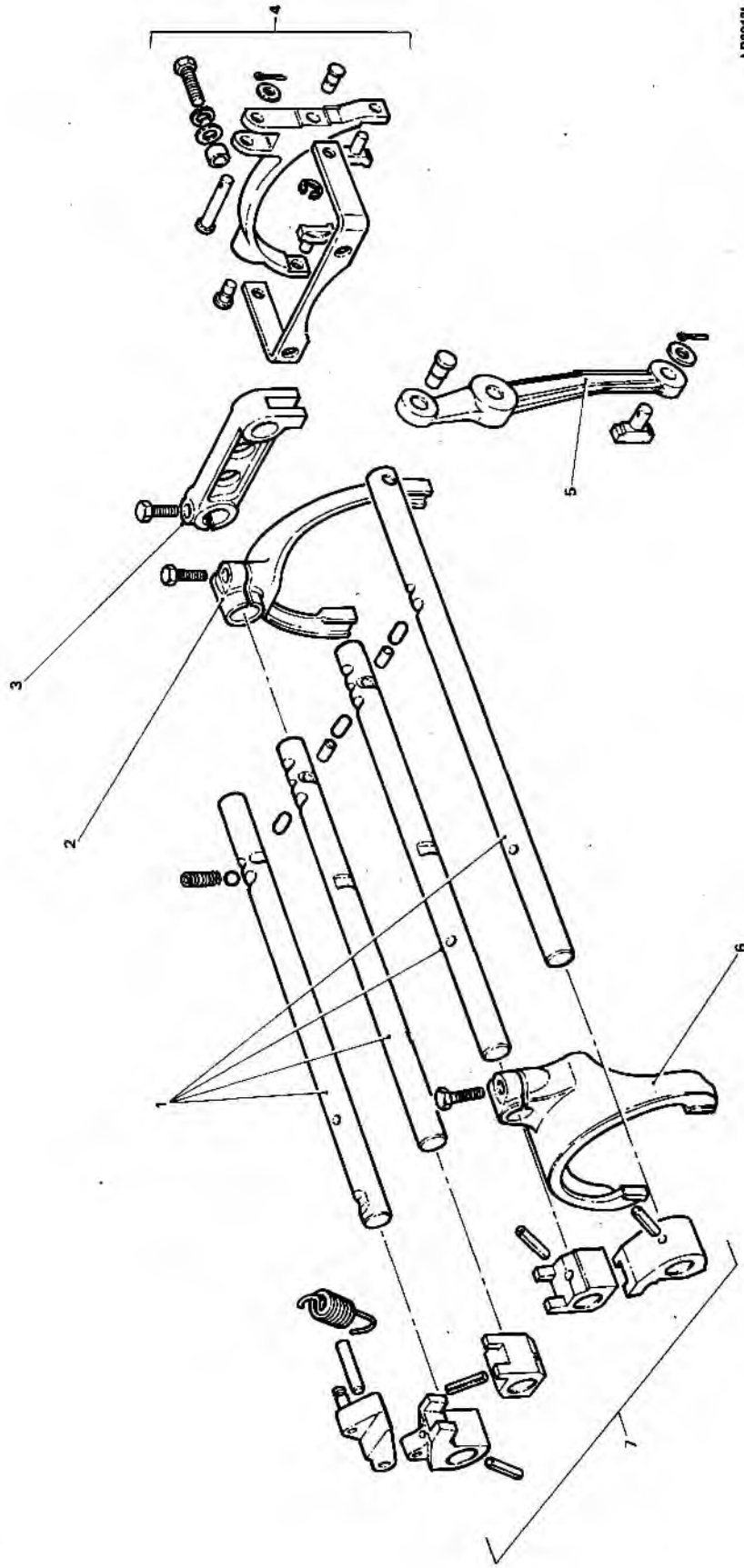
LR8012A

Fig 1
Gear casings

Fig 1

Fig 1





LR8013L

- 1 Selector rails
- 2 Fork 5th gear
- 3 Reverse cross-over lever
- 4 Fork 1st and 2nd gear
- 5 Selector arm reverse
- 6 Fork 3rd and 4th gear
- 7 Selector jaws

Gear selectors

Key to fig 3

Mainshaft assembly 'A'

- | | |
|---|----------------------------|
| 1 Mainshaft | 20 Needle roller bearing |
| 2 Circlip | 21 1st gear bush |
| 3 Selective washer | 22 Selective washer |
| 4 4th gear baulk ring | 23 Ball bearing |
| 5 1rd/4th gear synchro sleeve | 24 Snap ring |
| 6 3rd/4th gear synchro hub | 25 Circlip |
| 7 3rd gear baulk ring | 26 Washer |
| 8 Spacer | 27 Needle roller bearing |
| 9 3rd gear | 28 Spacer |
| 10 Needle roller bearing | 29 5th gear |
| 11 2nd gear | 30 5th gear baulk ring |
| 12 2nd gear baulk ring | 31 5th gear synchromesh |
| 13 Needle roller bearing | 32 5th gear synchro sleeve |
| 14 Spacer | 33 5th gear synchro plate |
| 15 1st/2nd gear synchro sleeve and reverse gear | 34 Dowel retaining plate |
| 16 1st/2nd gear synchro hub | 35 'O' ring seal |
| 17 1st gear baulk ring | 36 Sleeve |
| 18 1st gear | 37 Selective washer |
| 19 Spacer | 38 Circlip |

Input shaft assembly 'B'

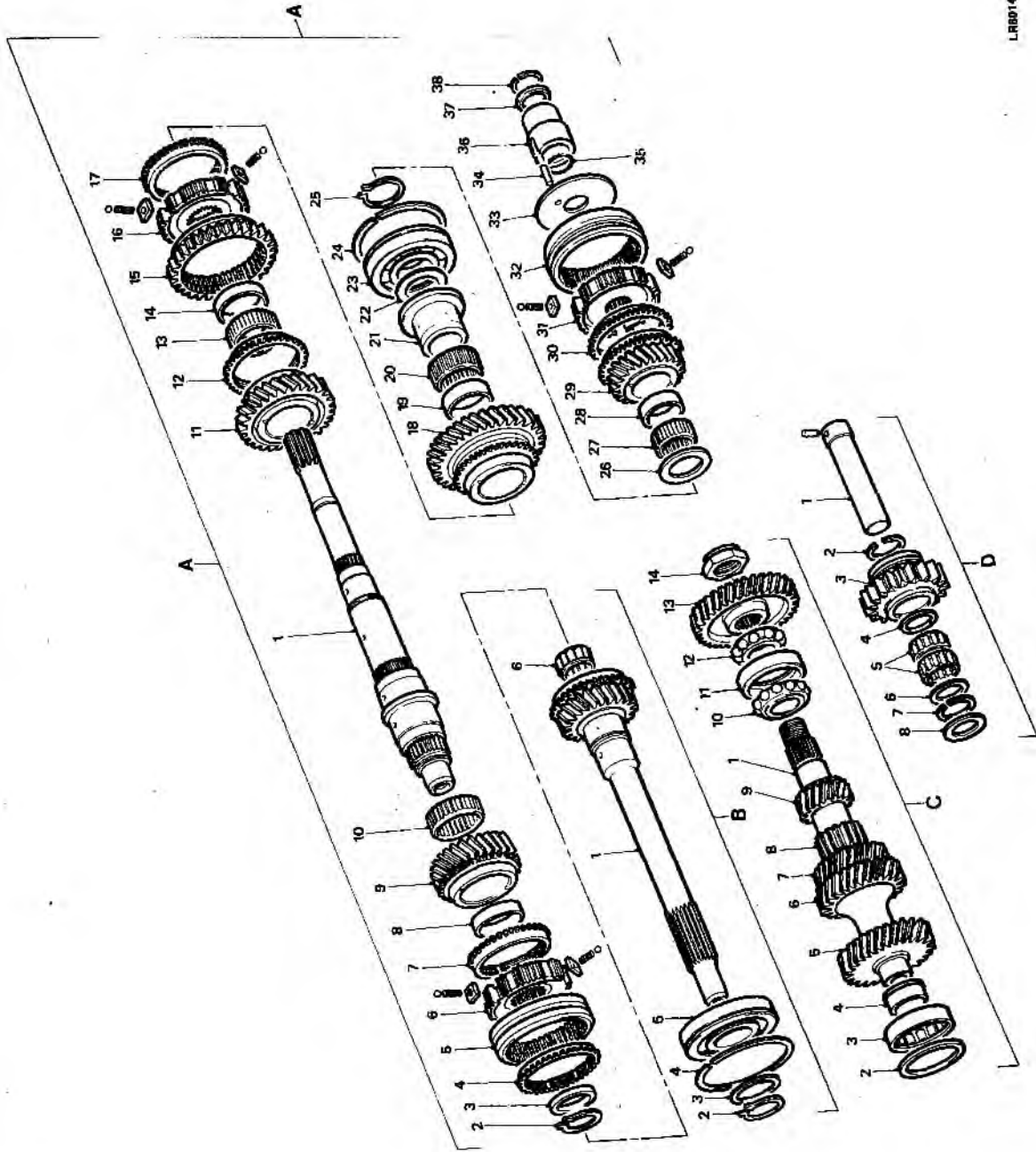
- | | |
|----------------------------|-------------------------|
| 1 Input shaft and 4th gear | 4 Snap ring |
| 2 Circlip | 5 Ball bearing |
| 3 Selective washer | 6 Needle roller bearing |

Layshaft assembly 'C'

- | | |
|------------------------|----------------------------|
| 1 Layshaft | 8 Reverse gear |
| 2 Spacer | 9 1st gear |
| 3 Roller bearing | 10 Inner ball bearing race |
| 4 Roller bearing track | 11 Bearing track |
| 5 4th gear | 12 Outer ball bearing race |
| 6 3rd gear | 13 5th gear |
| 7 2nd gear | 14 5th gear retaining nut |

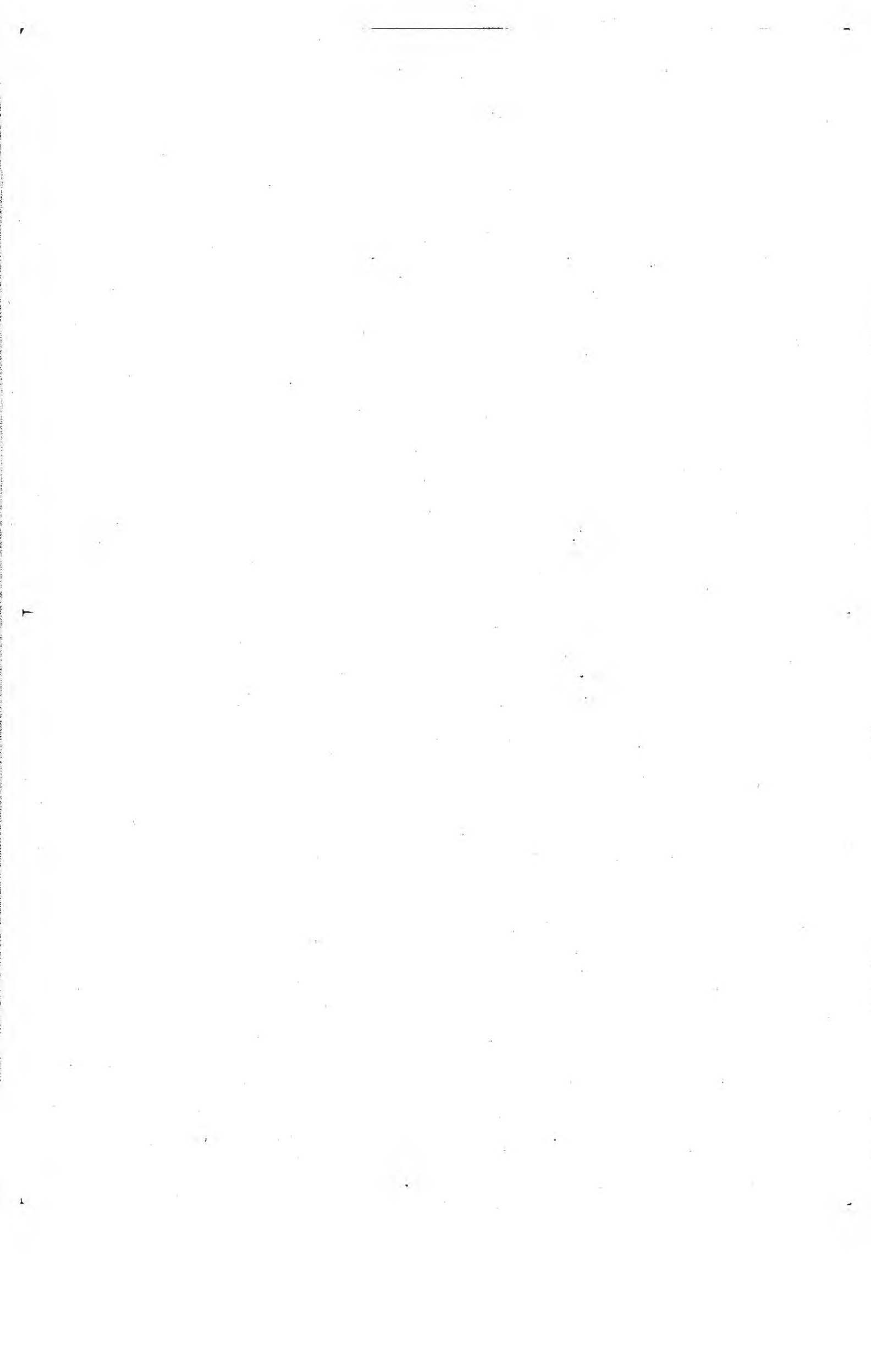
Reverse shaft assembly 'D'

- | | |
|----------------------------|-------------------------|
| 1 Reverse idler gear shaft | 5 Needle roller bearing |
| 2 Wire circlip | 6 Washer |
| 3 Reverse idler gear | 7 Wire circlip |
| 4 Washer | 8 Thrust washer |



LR8014L

Gears and shafts



Chapter 3-3

LT85 LIGHTWEIGHT DIVIDED-CASE GEARBOX

TECHNICAL DESCRIPTION

CONTENTS

Frame	Para		Page
	1	Introduction	
	2	General	
	10	Gear change lever	
	12	Castings	
	13	Lubrication and ventilation	
	Fig		
	1	Gear casings	3/4
	2	Gear selectors	5
	3	Gears and shafts	7/8

INTRODUCTION

1 This Chapter details the technical description for the LT85 Lightweight divided-case gearbox fitted to Land Rover 3.5 litre petrol 110 vehicles.

GENERAL

Note ...

The gearboxes fitted to MOD Land Rover 110 vehicles are fitted with special low ratio first and second gears. Under no circumstances should standard first and second gears or lay shaft clusters be fitted during repair or overhaul procedures.

2 The gearbox has five forward speeds and one reverse with synchromesh engagement provided on all forward speeds. All forward speed gears are of the helical type and are in constant mesh.

3 Three synchronizer assemblies are installed, one between the mainshaft first and second gears, one between the mainshaft third and fourth speed gears and one at the rear of the mainshaft fifth speed gear.

4 The input shaft is supported by a plain ball journal housed in the main casing. The mainshaft is supported by a plain ball journal housed in the main casing at the output end, and by a caged roller bearing fitted within the input gear on the input shaft.

5 The first, second, third and fifth mainshaft gears (Fig 3) are supported on caged needle roller bearings whilst the synchronizer assemblies are located on splines. The main fourth speed gear is formed on the inner end of the input shaft and the mainshaft reverse gear is integrated with the first and second speed synchronizer.

6 The layshaft is supported at the front end by a roller bearing housed in the main casing. The rear end is supported by a double taper, double row ball bearing housed in the main casing. All gears are formed as an integral part of the layshaft except the fifth gear which is a separate gear splined to the layshaft and secured by a staked nut.

7 The reverse idler gear which is fitted with two caged needle roller bearings retained by circlips is mounted on a stationery shaft secured between the rear end of the main casing and a lug within the main casting.

8 Engagement of the reverse idler gear with its associated gears on the main and layshafts is controlled by a lever and pivot via the gear change mechanism to the gearshift lever.

9 Forward speed gears are engaged by three shift forks attached to rods and inter-connected with the gear shift lever (Fig 2).

Gear change lever

10 The gear change lever is connected to a lower lever assembly supported in a housing attached to the top of the gearbox. The lower lever has a bulbous shape formed in the centre, allowing it to pivot on its seat to obtain the necessary movement required to achieve gear changing. A cross pin fitted through the bulbous portion of the lever locates in slots in the lever housing and prevents rotational movement.

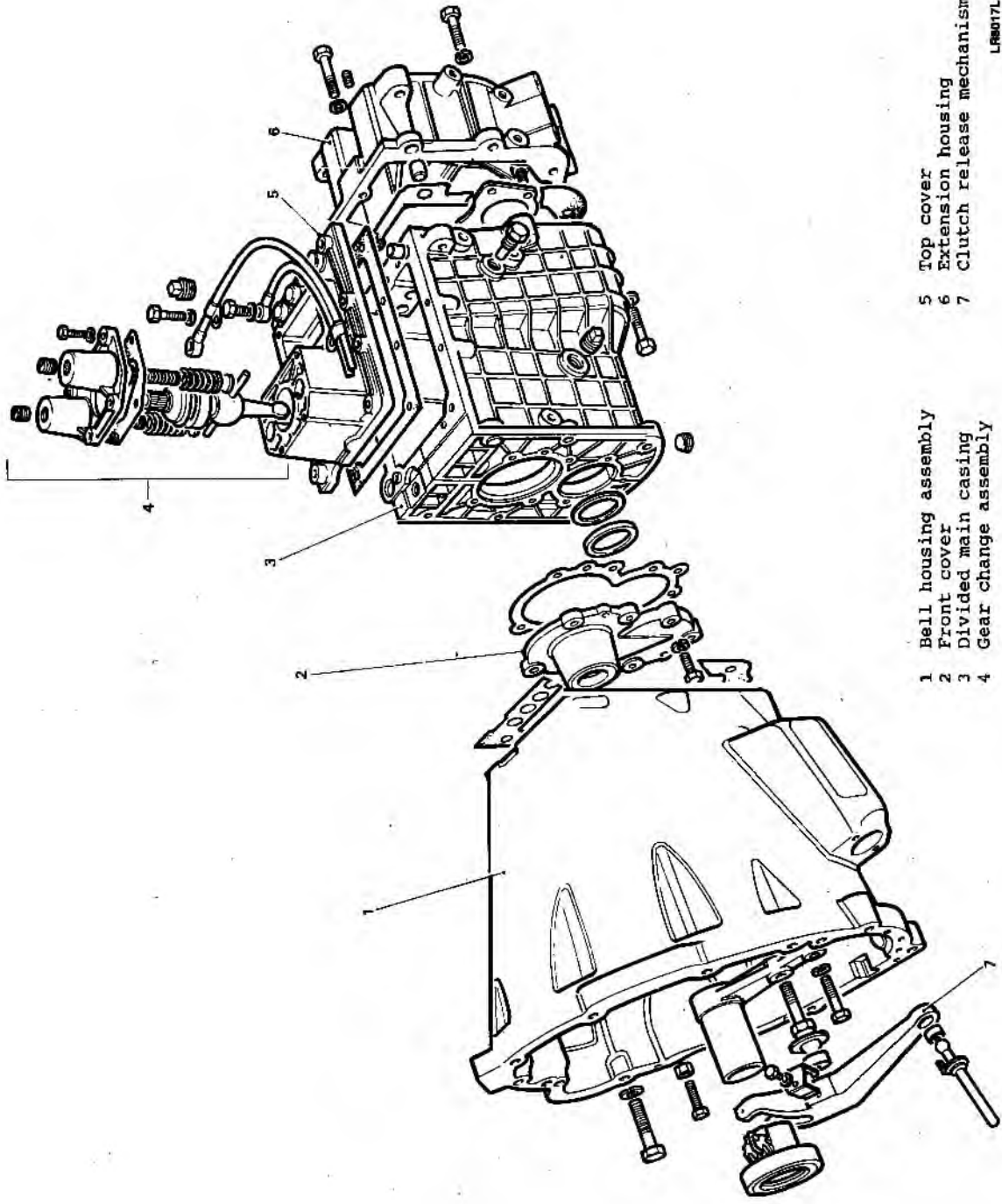
11 The bottom of the lever is a flattened ball shape which engages with one of four sets of selector jaws according to the position of the gear lever.

Casings

12 The gearbox casings (Fig 1) consist of a main casing split in two halves down the central axis and an extension housing. The casings house the geartrain mechanisms and provide housings for the bearings supporting the running shafts. The front end of the main casing carries a front cover (2) and the clutch bell housing (1), whilst the extension housing (6) at the rear forms the mounting for the transfer gearbox.

Lubrication and ventilation

13 Lubrication is achieved by splash from oil contained within the gearbox. Ventilation is via a banjo situated on the gear change lever housing.



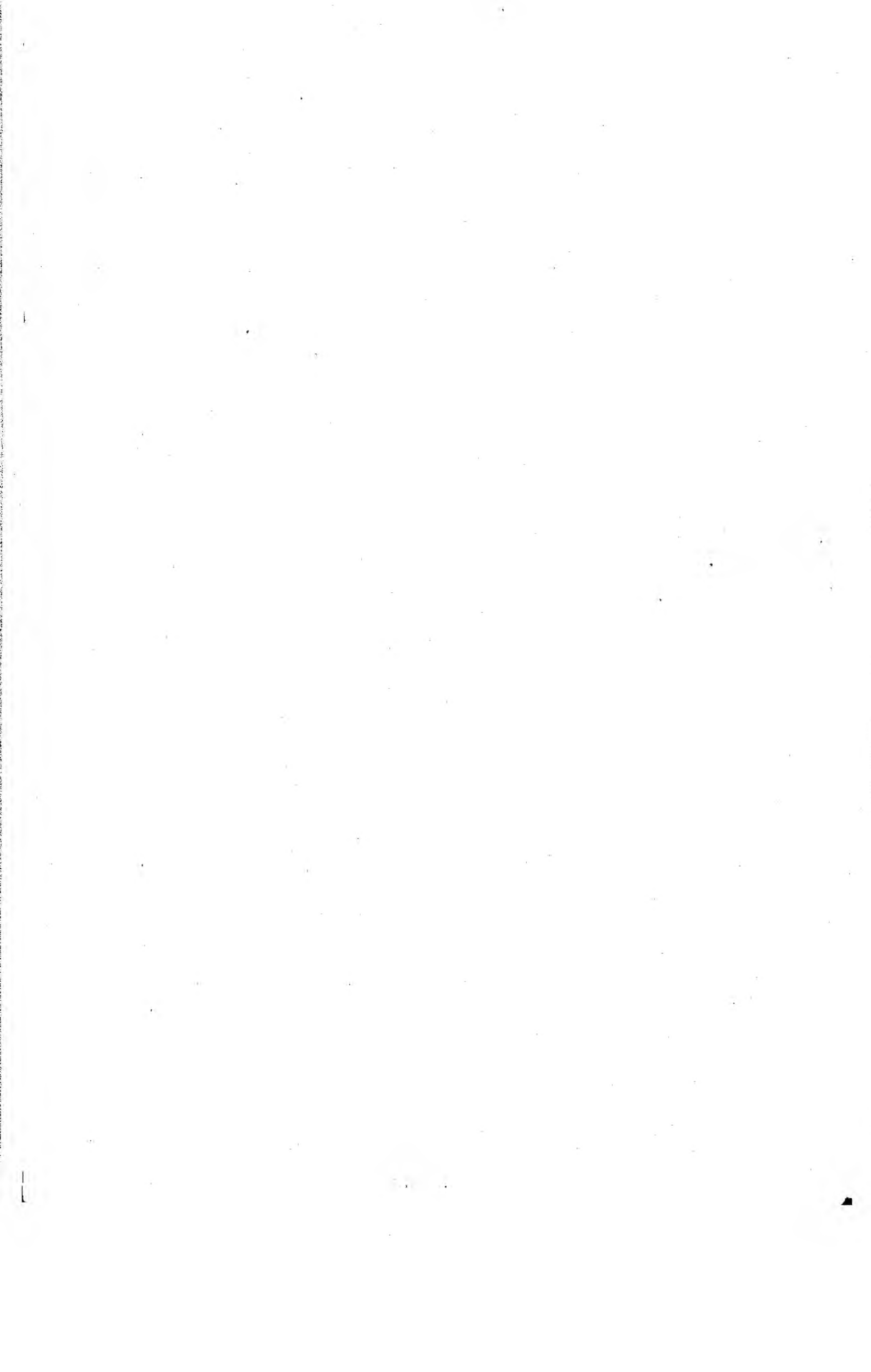
- 1 Bell housing assembly
- 2 Front cover
- 3 Divided main casing
- 4 Gear change assembly

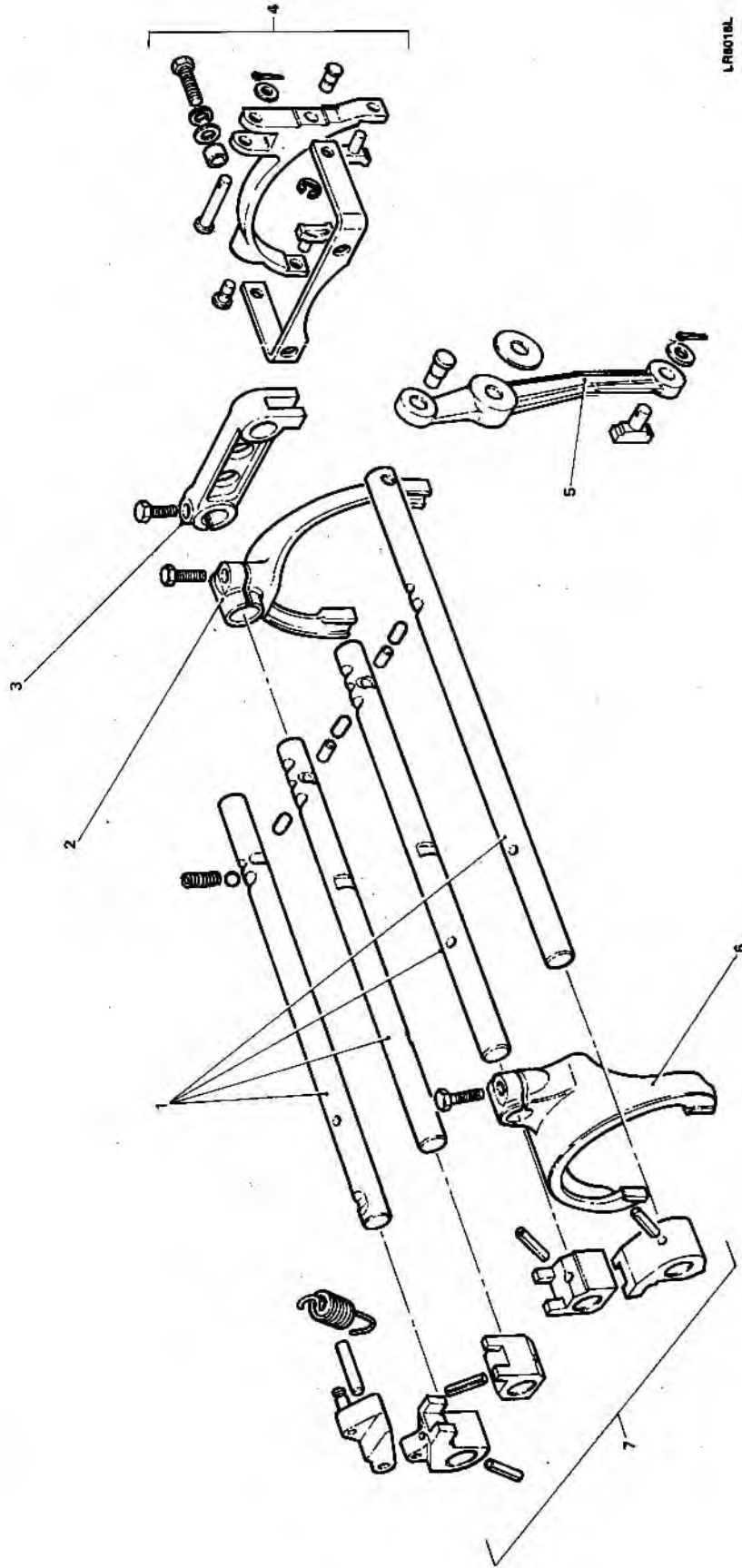
- 5 Top cover
- 6 Extension housing
- 7 Clutch release mechanism

LR6017L

Gear casings

Fig 1





- 5 Selector arm reverse
- 6 Fork 3rd and 4th gear
- 7 Selector jaws

- 1 Selector rails
- 2 Fork 5th gear
- 3 Reverse cross-over lever
- 4 Fork 1st and 2nd gear

Gear selectors

Key to fig 3

Mainshaft assembly 'A'

1	Mainshaft	20	Needle roller bearing
2	Circlip	21	1st gear bush
3	Selective washer	22	Selective washer
4	4th gear baulk ring	23	Ball bearing
5	3rd/4th gear synchro sleeve	24	Snap ring
6	3rd/4th gear synchro hub	25	Circlip
7	3rd gear baulk ring	26	Washer
8	Spacer	27	Needle roller bearing
9	3rd gear	28	Spacer
10	Needle roller bearing	29	5th gear
11	2nd gear	30	5th gear baulk ring
12	2nd gear baulk ring	31	5th gear synchromesh
13	Needle roller bearing	32	5th gear synchro sleeve
14	Spacer	33	5th gear synchro plate
15	1st/2nd gear synchro sleeve	34	Dowel retaining plate
16	and reverse gear	35	'O' ring seal
17	1st/2nd gear synchro hub	36	Sleeve
18	1st gear baulk ring	37	Selective washer
19	Spacer	38	Circlip

Input shaft assembly 'B'

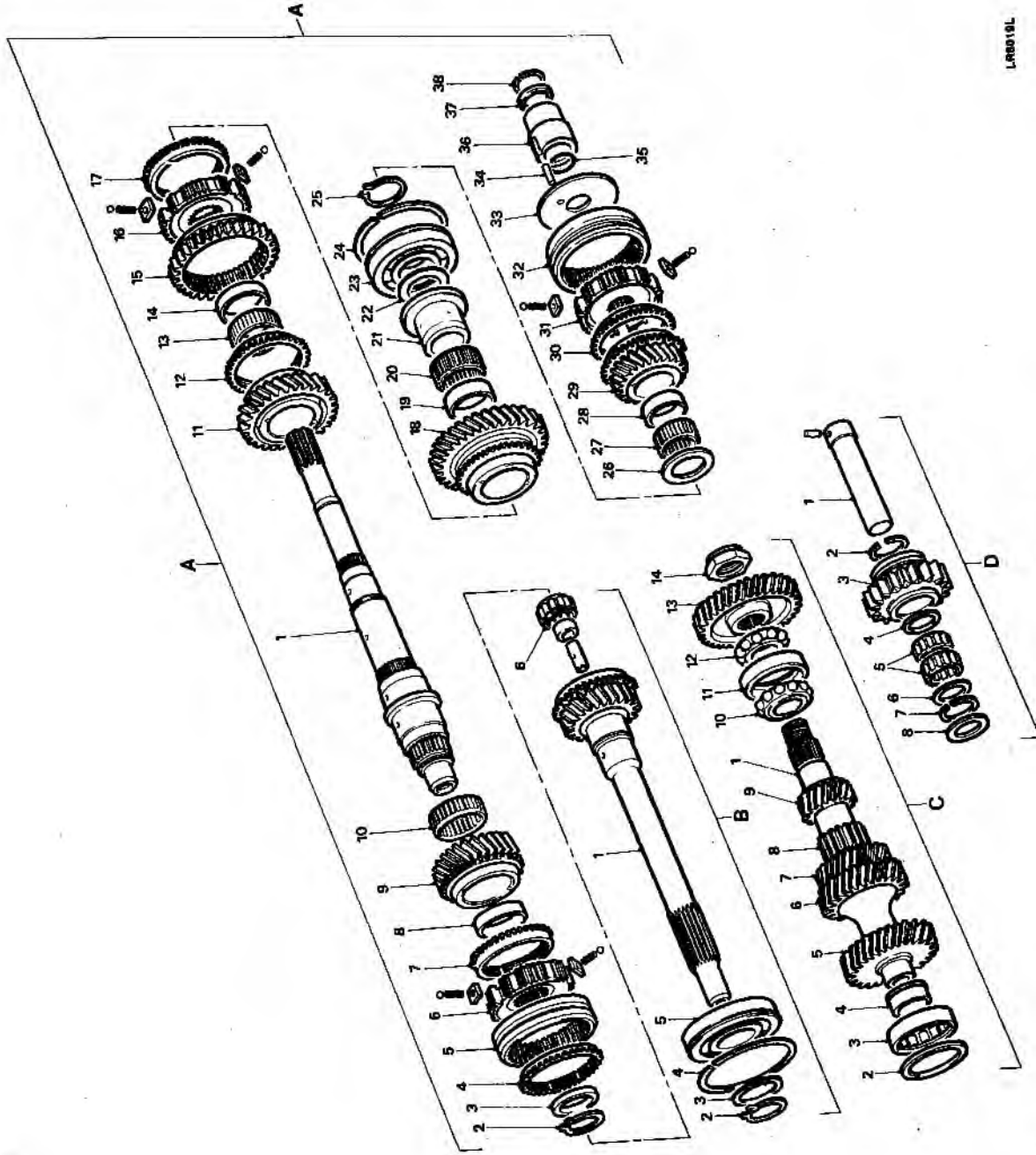
1	Input shaft and 4th gear	4	Snap ring
2	Circlip	5	Ball bearing
3	Selective washer	6	Needle roller bearing

Layshaft assembly 'C'

1	Layshaft	8	Reverse gear
2	Spacer	9	1st gear
3	Roller bearing	10	Inner ball bearing race
4	Roller bearing track	11	Bearing track
5	4th gear	12	Outer ball bearing race
6	3rd gear	13	5th gear
7	2nd gear	14	5th gear retaining nut

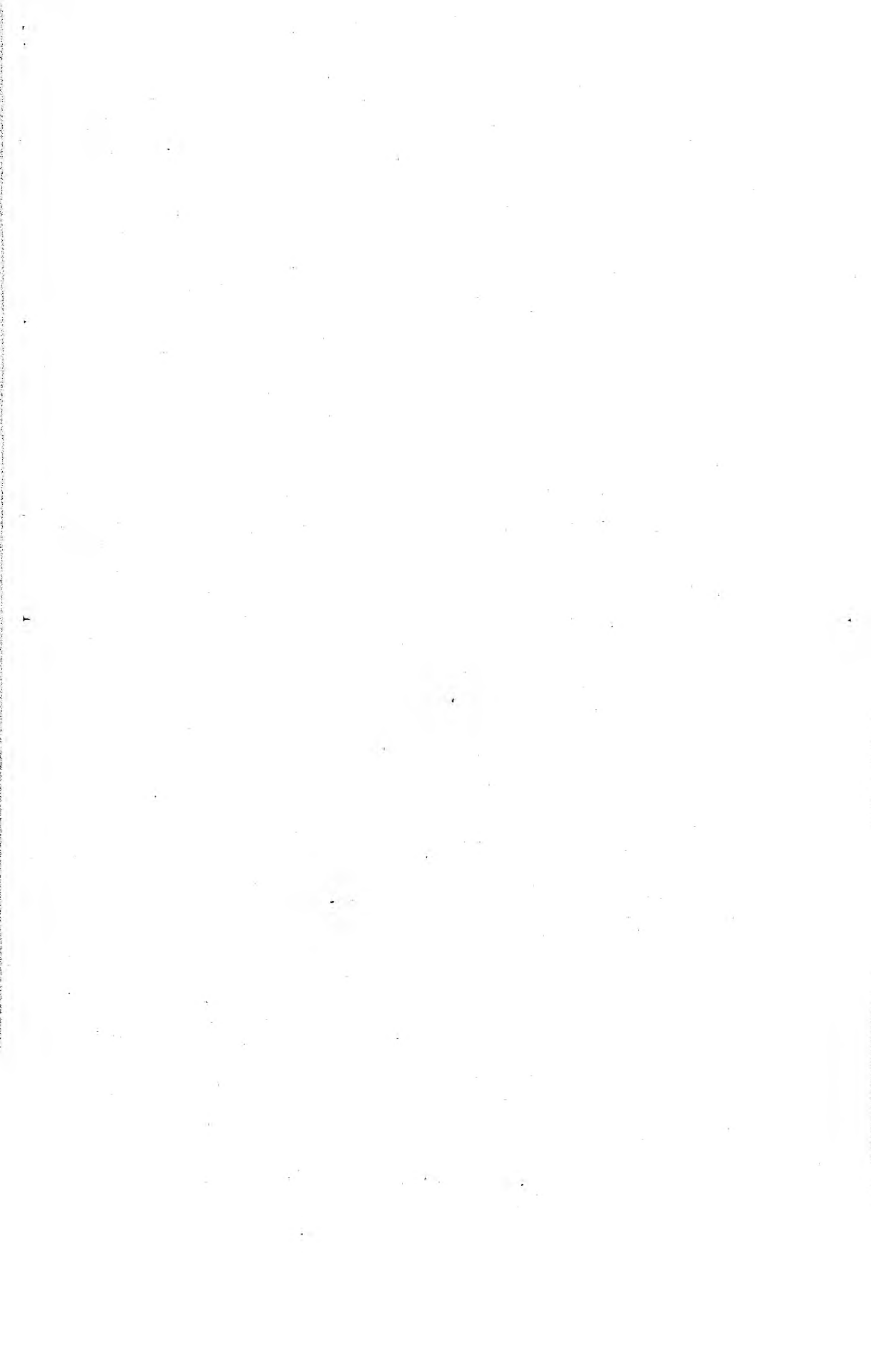
Reverse shaft assembly 'D'

1	Reverse idler gear shaft	5	Needle roller bearing
2	Wire circlip	6	Washer
3	Reverse idler gear	7	Wire circlip
4	Washer	8	Thrust washer



LR8016L

Gears and shafts



Chapter 4

TRANSMISSION

TRANSFER GEARBOX AND PROPELLER SHAFTS

CONTENTS

Frame Para

- 1 Introduction
Transfer gearbox
- 2 General
- 3 Differential
- 5 Transfer gear change
- 6 Lubrication
- 7 Propeller shafts

Fig

Page

- 1 Transfer gearbox case and gears
- 2 Front output housing and selector assembly
- 3 Centre differential assembly
- 4 Rear output drive and transmission
- 5 Propeller shaft

- 2
- 3
- 4
- 5
- 6

INTRODUCTION

1 This chapter covers the technical description for the LT 230T Transfer gearbox and propeller shafts as fitted to Land Rover 90 and 110 vehicles.

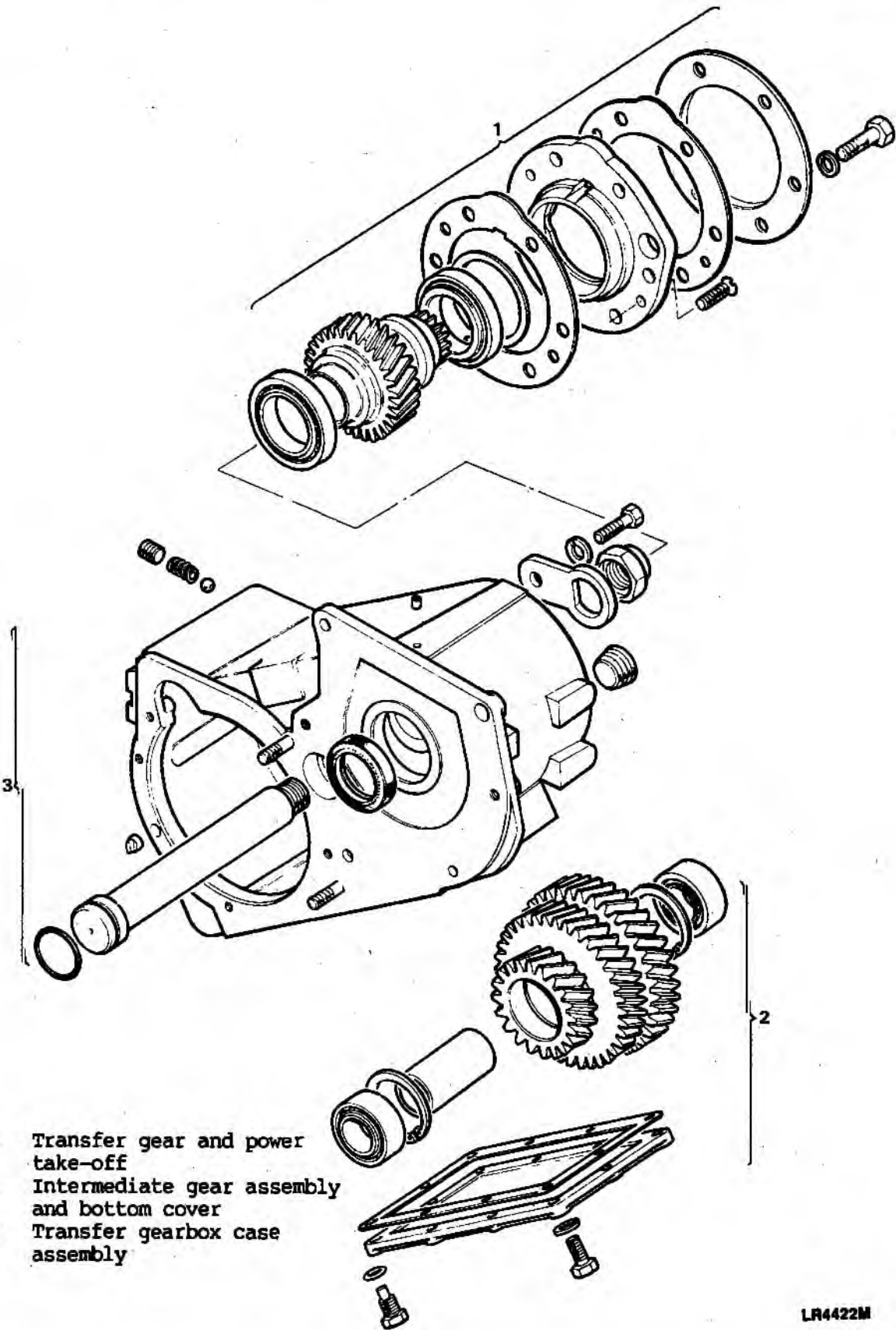
TRANSFER GEARBOX

General

2 The transfer gearbox is mounted at the rear of the main gearbox, the mainshaft of the gearbox extends into the transfer casing. A transfer gear supported in taper roller bearings and splined to the gearbox main shaft passes the drive to an intermediate gear cluster supported on a single shaft and rotating on taper roller bearings (Fig 1). The intermediate gears pass the drive to high and low speed gears on the rear output shaft. The rear output shaft passes through the speedometer drive housing, this housing also forms the mounting for the transmission brake (Fig 2). A worm gear fitted to the rear output shaft drives a pinion fitted in the speedometer housing.

Differential

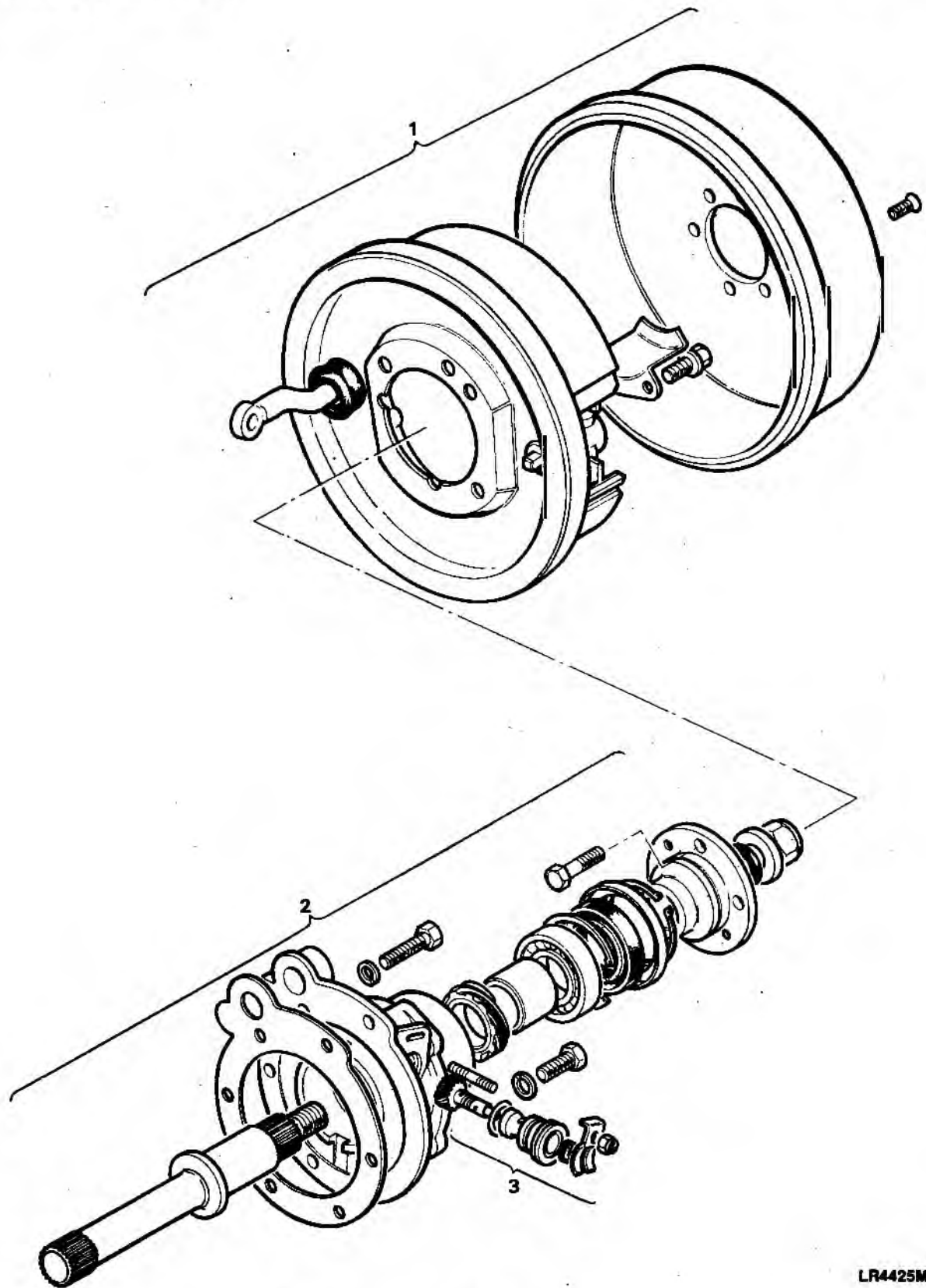
3 Integral with the output shafts is a differential assembly (Fig 3) which is provided to compensate for speed difference between front and rear propeller shafts. To prevent all power being transmitted to the wheel offering the least resistance, during off road conditions, a differential lock is provided. When applied the lock ensures that 50% of the available power is directed to each axle through the propeller shafts.



- 1 Transfer gear and power take-off
- 2 Intermediate gear assembly and bottom cover
- 3 Transfer gearbox case assembly

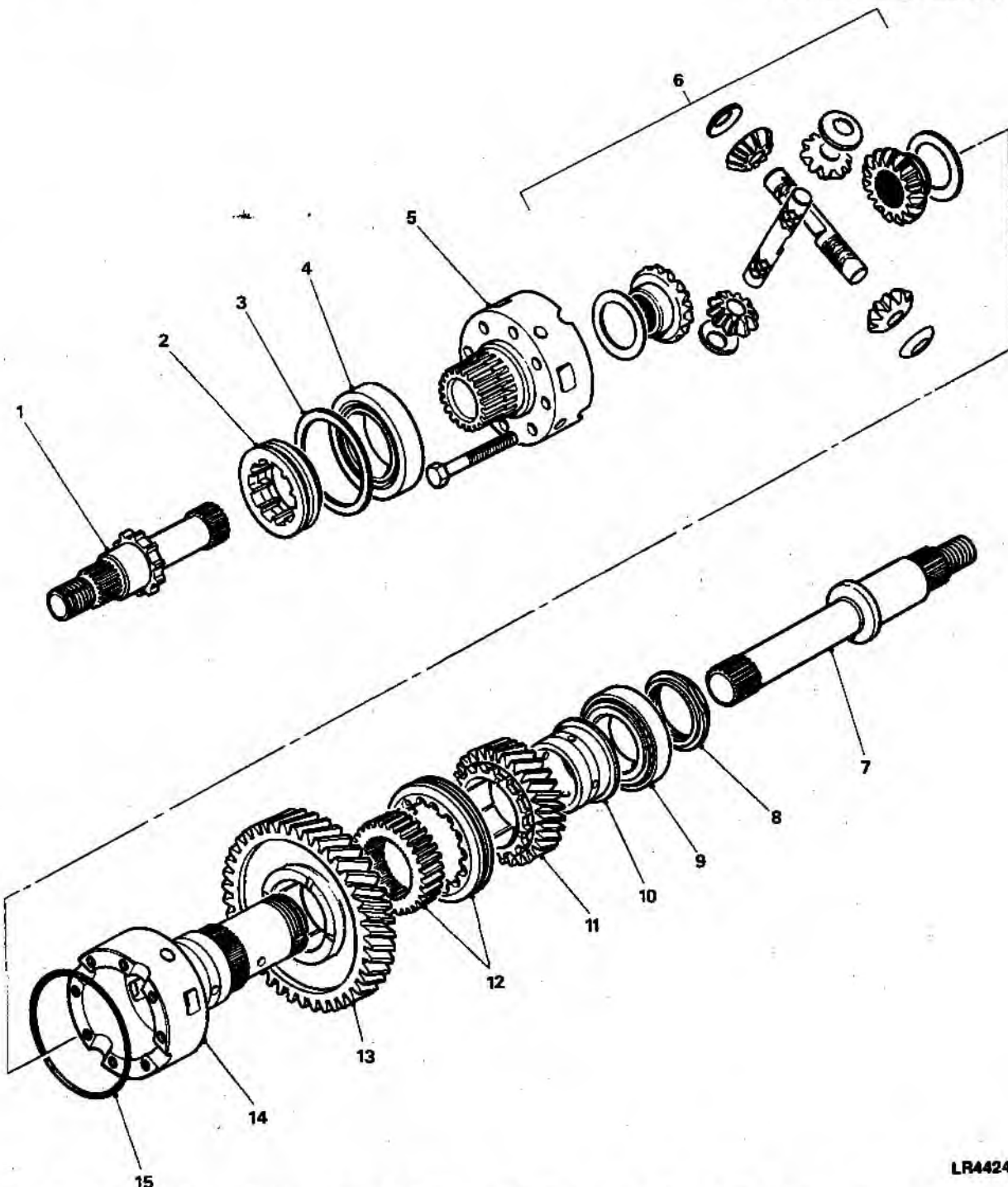
LR4422M

Fig 1 Transfer gearbox case and gears



- 1 Transmission brake
- 2 Rear output drive
- 3 Speedometer gear and housing

Fig 2 Rear output drive and transmission brake

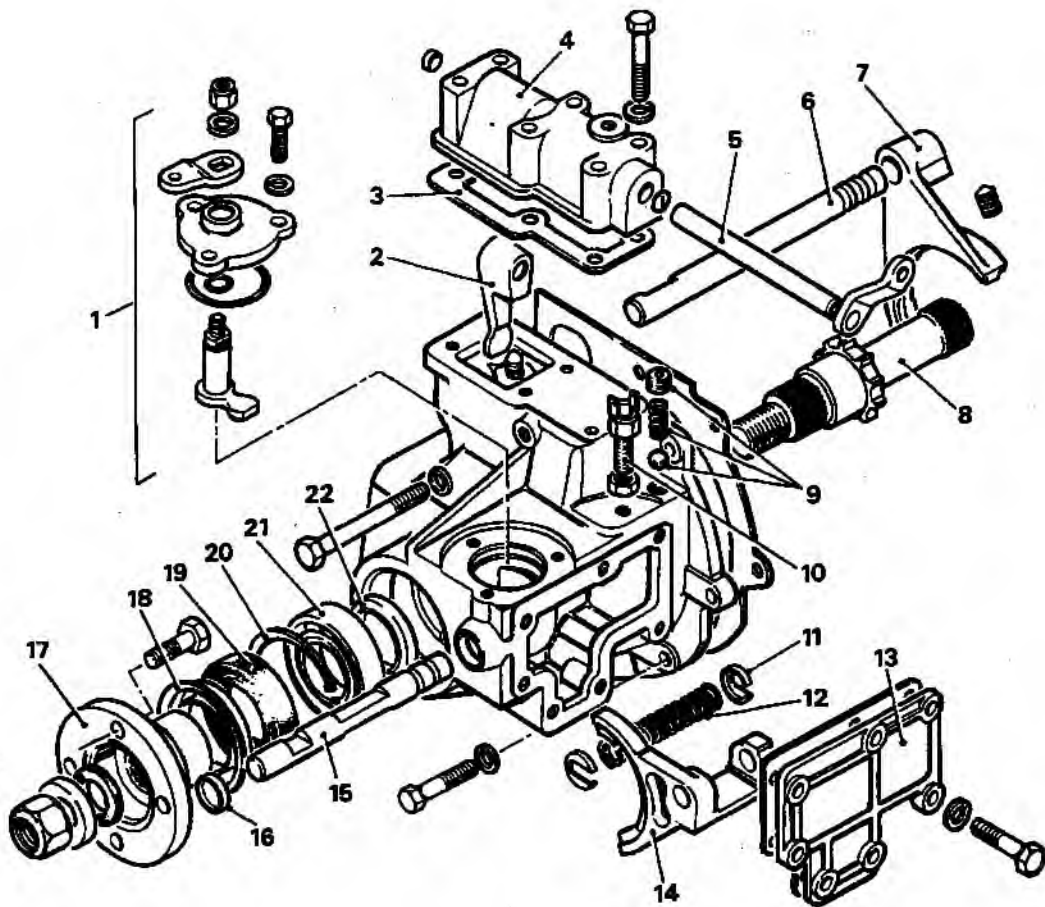


LR4424M

- | | | |
|------------------------------|---------------------------------------|------------------------------|
| 1 Front output shaft | 6 Differential gears and cross shafts | 11 High output gear |
| 2 Dog clutch | 7 Rear output shaft | 12 Hub and sleeve assembly |
| 3 Shim | 8 Nut bearing retainer | 13 Low output gear |
| 4 Bearing | 9 Bearing | 14 Rear differential housing |
| 5 Front differential housing | 10 Bush | 15 Locking ring |

Fig 3 Centre differential assembly

4 Selection of differential lock engages, through mechanical linkage, a dog clutch with the front output shaft, this action locks the centre differential and provides a fixed drive, giving equal power to the front and rear output shafts. When the differential lock is engaged a lamp is illuminated on the drivers warning lamp panel.



LR4423 /

- | | | | |
|----|---|----|----------------------------------|
| 1 | Differential lock selector finger housing | 12 | Differential lock spring |
| 2 | High/low operating arm | 13 | Front cover output housing |
| 3 | Gasket | 14 | Differential lock selector fork |
| 4 | High/low cross shaft housing | 15 | Differential lock selector shaft |
| 5 | High/low operating arm | 16 | Plug |
| 6 | High/low selector shaft | 17 | Front output flange |
| 7 | High/low selector fork | 18 | Mud shield |
| 8 | Front output shaft | 19 | Oil seal |
| 9 | Detent plug spring and ball | 20 | Circlip |
| 10 | Differential lock switch | 21 | Bearing |
| 11 | Spring clip | 22 | Spacer |

Fig 4 Front output housing and selector assembly

Transfer gear change

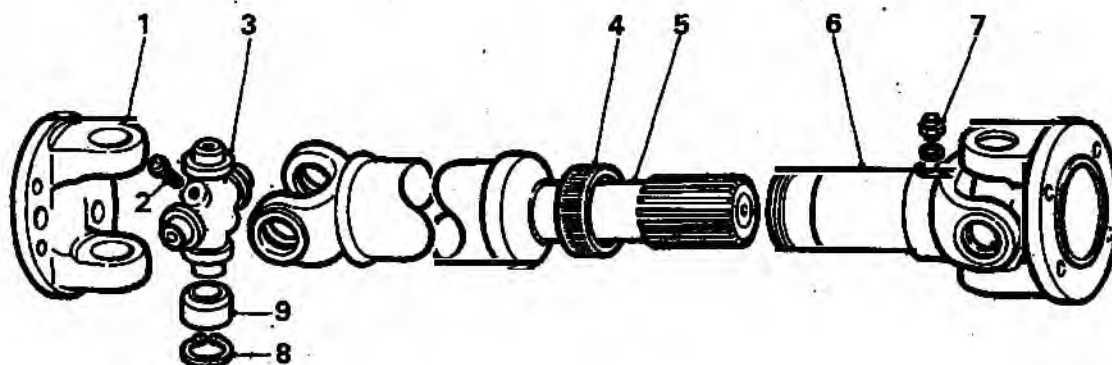
5 Transfer gear changing is obtained via a selector shaft passing forward through the front output housing to the transfer gear change level at the rear of the main gear change lever (Fig 4).

Lubrication

6 The lubrication system is self contained within the casings, oil circulation is achieved by the rotation of the gears, thereby splash feeding lubricant throughout the transfer gearbox.

PROPELLER SHAFTS

7 The front and rear propeller shafts, although not interchangeable, are identical from a design aspect. To accommodate fore and aft movement of the axles and the float of the engine and gearbox unit, one end of each shaft is provided with a splined sliding joint. Each universal joint consists of a centre spider, four needle roller bearing assemblies and two yokes. Lubrication nipples are provided for the needle roller bearing and for the splined sliding joint. The propeller shafts (front and rear) should be fitted with the sliding (splined) joint adjacent to the transfer box.



LR4432M

1	Flange yoke	6	Splined sleeve
2	Lubrication nipple	7	Lubrication nipple
3	Journal spider	8	Circlip securing bearing
4	Dust cap	9	Needle roller bearing
5	Splined shaft		

Fig 5 Propeller shaft

Chapter 5

REAR AXLES

INTRODUCTION

1 This Chapter gives the technical descriptions for the rear axles fitted to Land Rover 90 and 110 vehicles.

2 The Chapter has been Sub-chaptered as follows to accommodate the Salisbury type axle, fitted to Land Rover 110 vehicles and the heavy duty axle, fitted to Land Rover 90 vehicles:

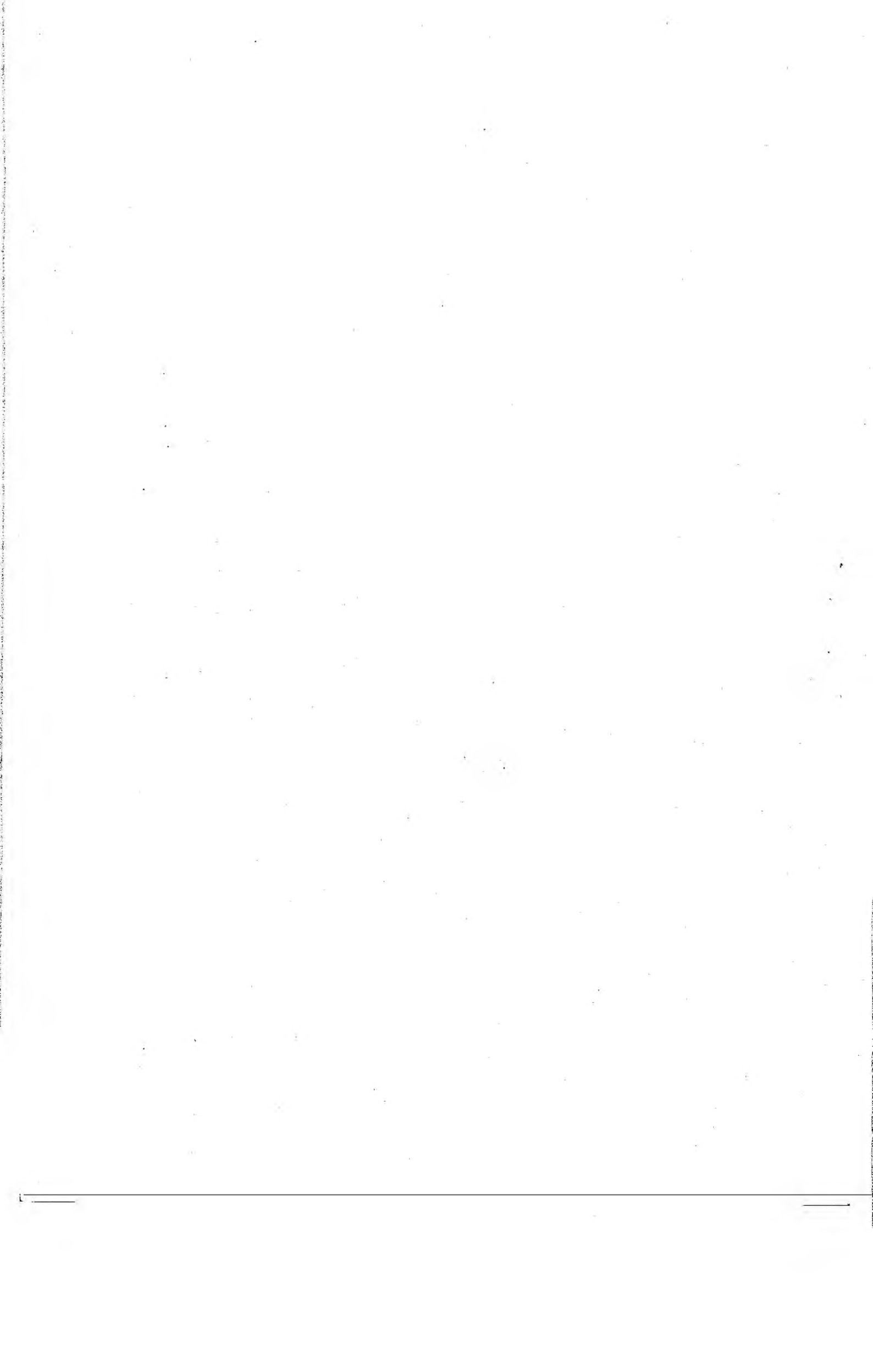
General

3 The information given is applicable to both left and right hand drive vehicles.

List of Sub-chapters

5-1 Rear axle Salisbury Type - 8HA

5-2 Land Rover heavy duty rear axle



Chapter 5-1

REAR AXLE SALISBURY TYPE - 8HA

CONTENTS

Frame Para

- 1 Introduction
- 2 Description
- 4 Operation
- 5 Lubrication

Fig

- 1 Rear axle Salisbury type
- 2 Rear hub assembly
- 3 Differential assembly in axle casing

Page

- 1
- 2
- 3

INTRODUCTION

1 This chapter covers the technical description for the Salisbury type rear axle as fitted to Land Rover 110 vehicles.

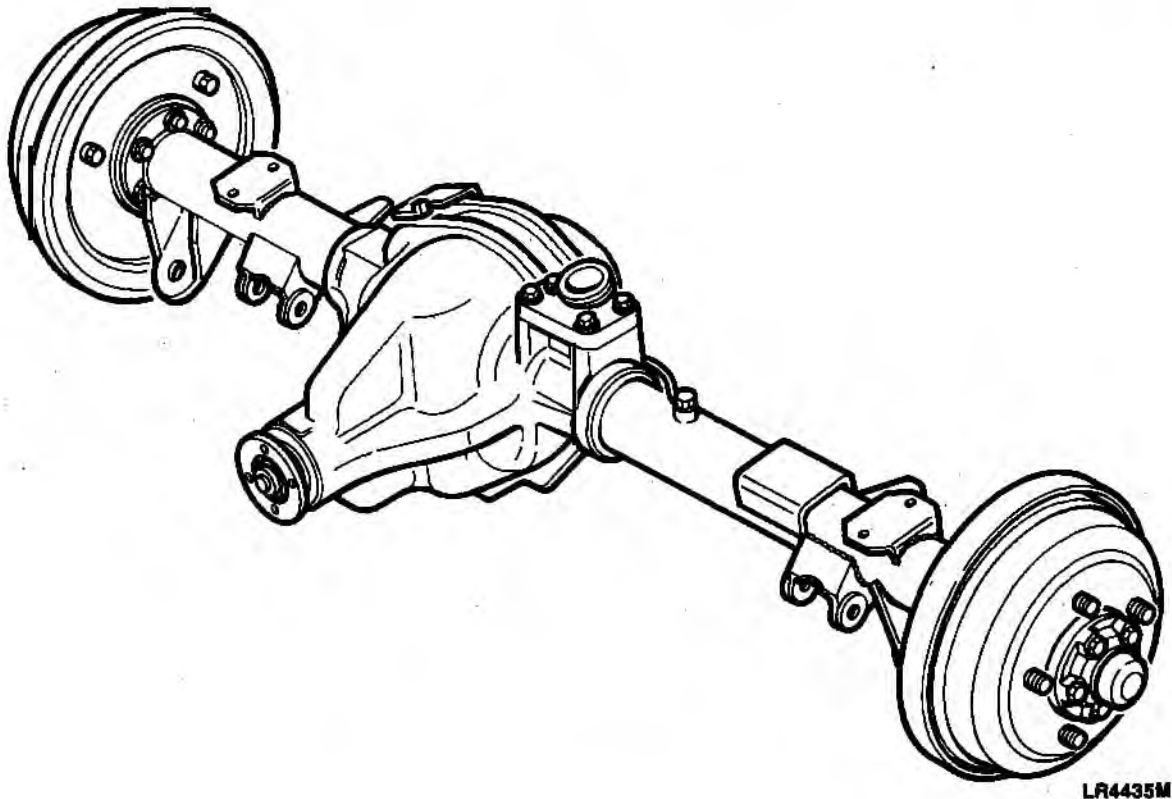
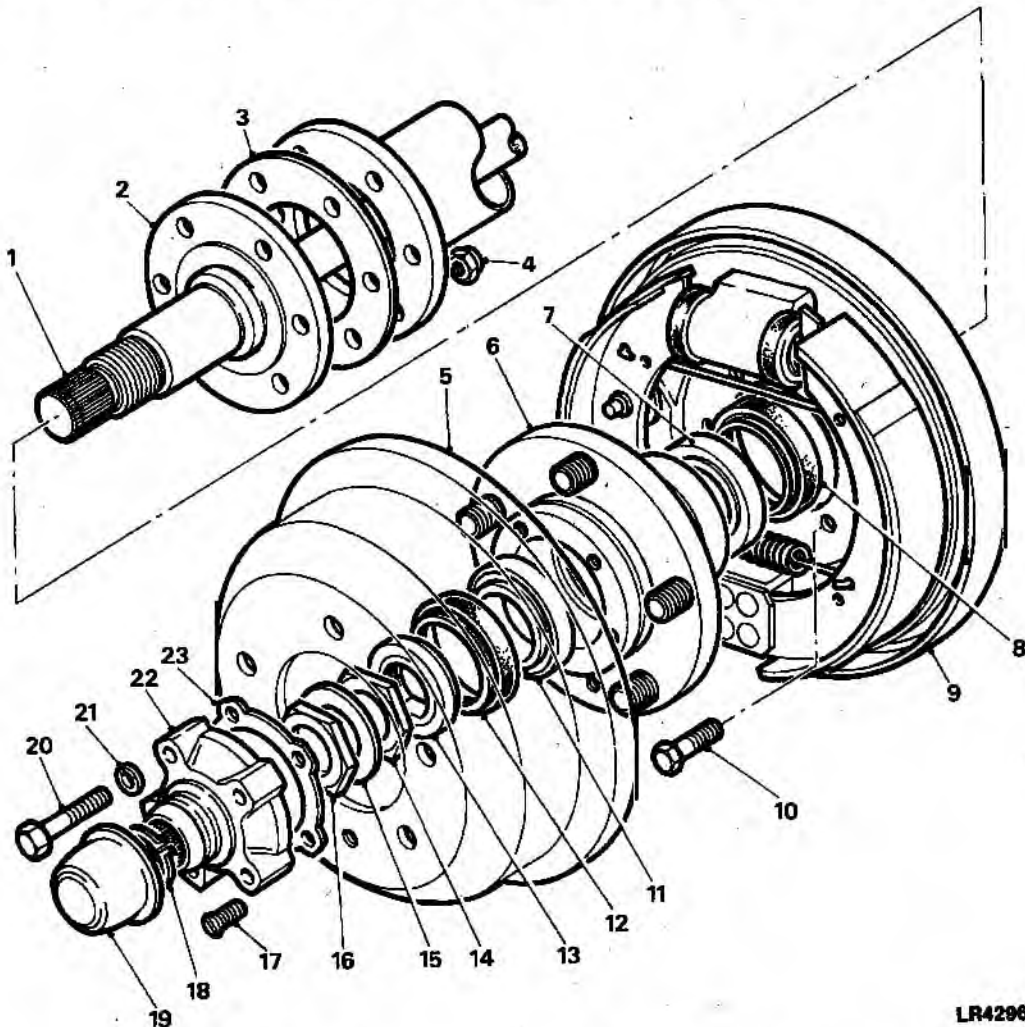


Fig 1 Rear axle Salisbury Type - 8HA

Description

2 The rear axle (Fig 1) incorporates the Salisbury heavy duty differential and axle casing, the differential is off-set to the right hand side. The hubs being carried through taper roller bearings on a stub axle which is attached to the axle casing. The hubs are grease packed and do not require further lubrication unless they are dismantled, a dual lipped seal is fitted to the front and rear of the hub and prevents seepage of grease. A drive member having an internal splined fit to the axle shaft is secured to the hub by bolts (Fig 2).



LR4296M

- | | | | |
|----|-----------------|----|--------------------|
| 1 | Axle half shaft | 13 | Seal track spacer |
| 2 | Stub axle | 14 | Adjusting nut |
| 3 | Gasket | 15 | Lock washer |
| 4 | Locknut | 16 | Locknut |
| 5 | Brake drum | 17 | Screw |
| 6 | Hub | 18 | Circlip |
| 7 | Inner bearing | 19 | Hub cap |
| 8 | Inner oil seal | 20 | Bolt |
| 9 | Brake backplate | 21 | Spring washer |
| 10 | Bolt | 22 | Hub driving member |
| 11 | Outer bearing | 23 | Gasket |
| 12 | Outer oil seal | | |

Fig 2 Rear hub assembly

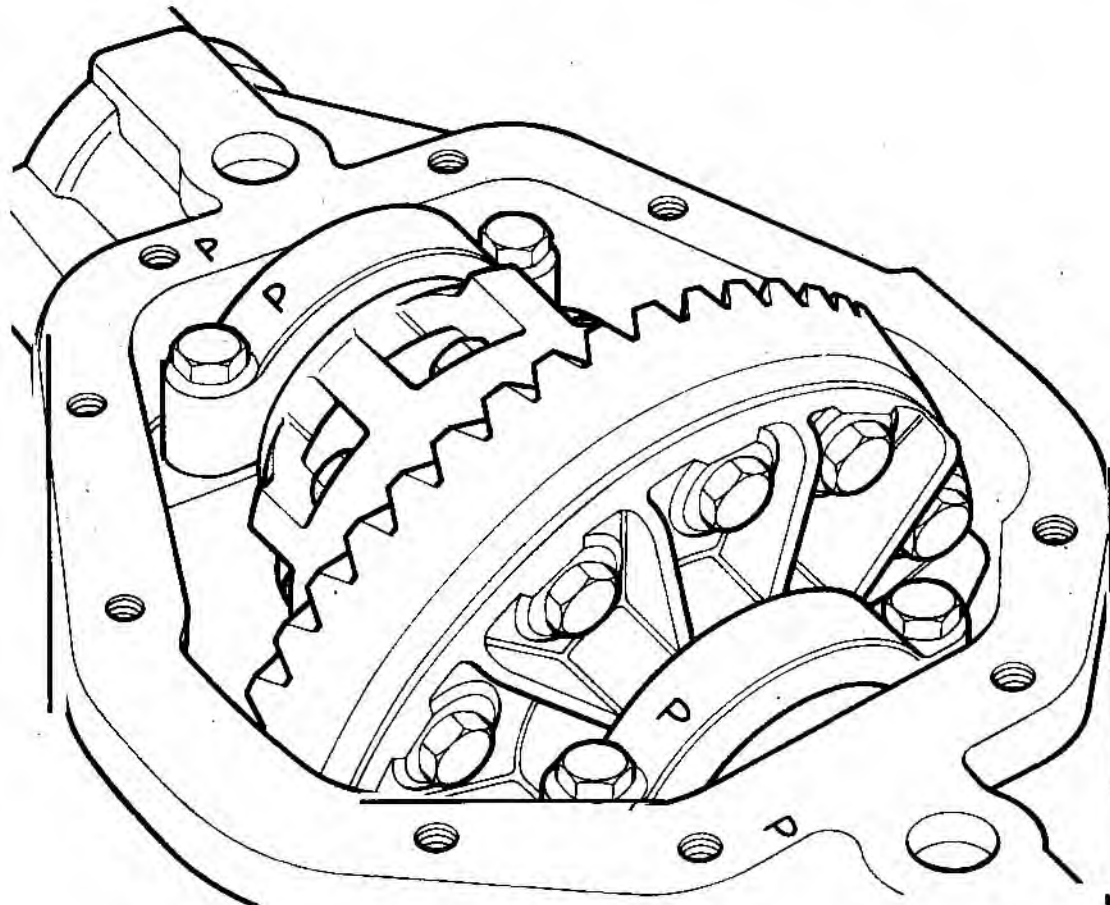
3 The differential case comprises two halves which form the housing for the differential pinions and wheels, when assembled, the crown wheel is mounted on taper roller bearing and supported by the bevel pinion housing. The differential wheels have internal splines which carry the fully floating axle shafts. Housed within the integral differential/axle casing the bevel pinion is mounted on taper roller bearings, and is adjusted for pre-load and correct positioning by shims fitted under the inner bearing cup and a collapsible spacer, fitted between the bearings. Backlash setting of the crown wheel is effected by fitting shims between the differential case and the bearing cone at the crown wheel side of the differential.

Operation

4 Drive is transmitted from the propellor shaft to the bevel pinion, then to the crown wheel, from the crown wheel to the differential casing and pinions through the differential wheels and on to the axle shafts.

Lubrication

5 The differential is oil lubricated, having a filler/level plug fitted at the rear of the axle casing and an oil drain plug fitted to the underside of the casing. Breathing is achieved through a banjo connection in the top of the casing and is passed to the engine compartment via plastic tubing.



LR4436M

Fig 3 Differential assembly in axle casing



Chapter 5-2

LAND ROVER HEAVY DUTY REAR AXLE

CONTENTS

Frame Para

- 1 Introduction
- 2 Description
- 3 Operation
- 4 Lubrication

Fig

- 1 Land Rover heavy duty rear axle
- 2 Rear hub assembly
- 3 Differential assembly

Page

- 1
- 2
- 3

INTRODUCTION

1 This chapter covers the technical description for the heavy duty type rear axle as fitted to Land Rover 90 vehicles.

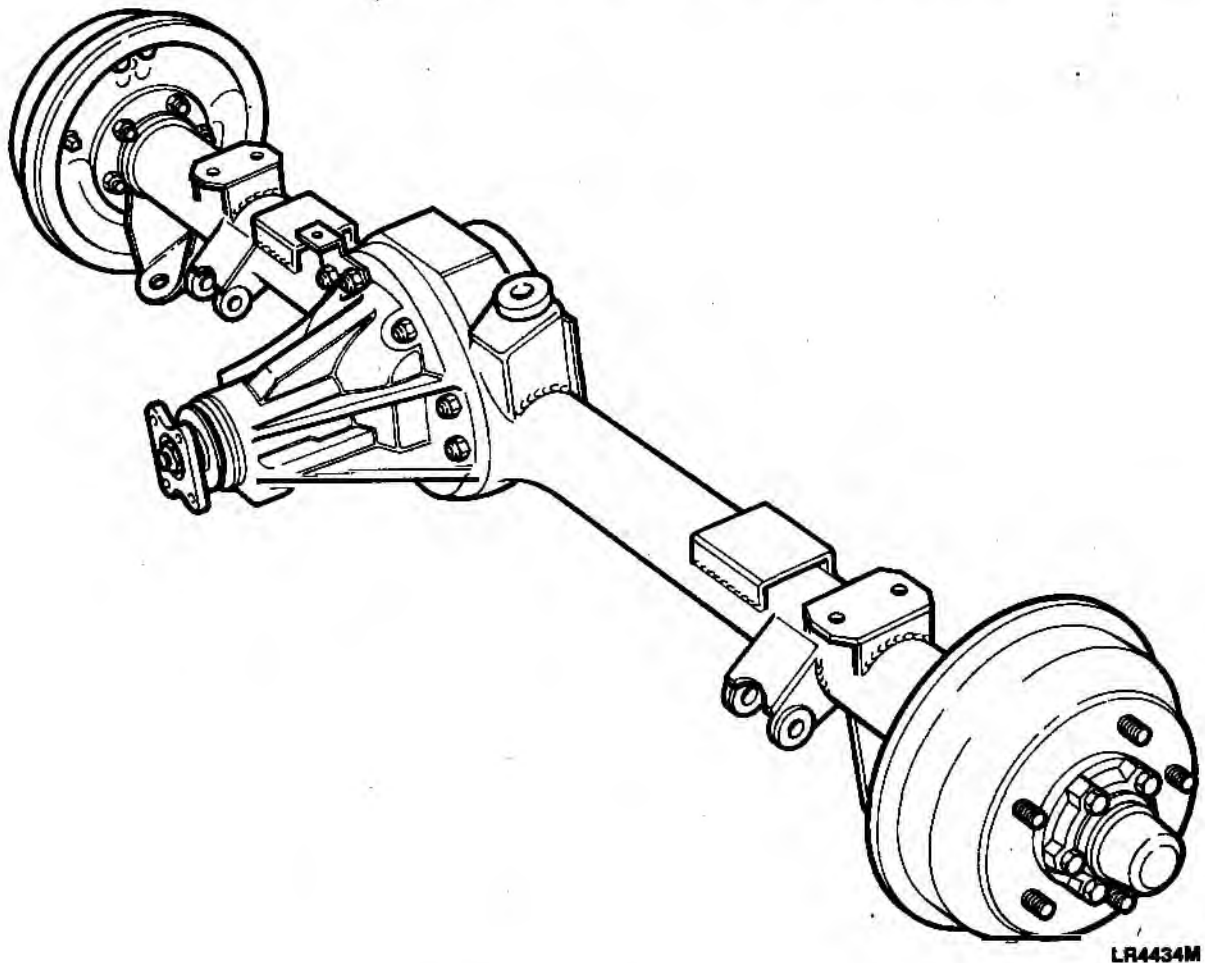
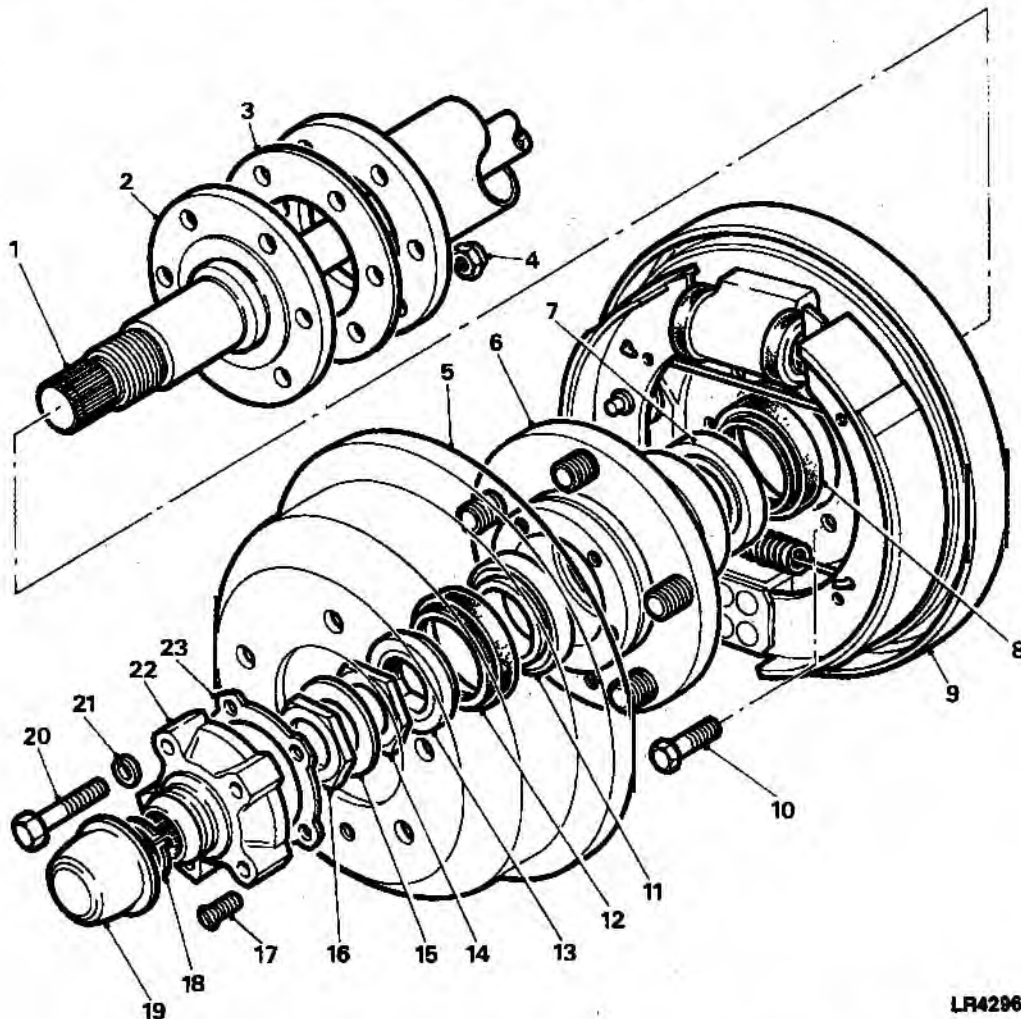


Fig 1 Land Rover heavy duty rear axle

Description

2 The Land Rover heavy duty rear axle (Fig 1) is of the fully floating type, with the differential off-set to the right hand side. The hubs being carried through taper roller bearings on stub axles which are attached to the axle casing. The hubs are grease packed and do not require further lubrication, unless they are dismantled, a dual lipped seal is fitted to the front and rear of the hub and prevents seepage of grease. A drive member having an internal splined fit to the axle shaft is secured to the hub by bolts (Fig 2).



1	Axle half shaft	13	Seal track spacer
2	Stub axle	14	Adjusting nut
3	Gasket	15	Lock washer
4	Locknut	16	Locknut
5	Brake drum	17	Screw
6	Hub	18	Circlip
7	Inner bearing	19	Hub cap
8	Inner oil seal	20	Bolt
9	Brake backplate	21	Spring washer) Hub driving
10	Bolt	22	Hub driving member) member
11	Outer bearing	23	Gasket
12	Outer oil seal		

Fig 2 Rear hub assembly

3 The differential case assembly complete with crown wheel, differential pinions and wheels, mounted on taper roller bearings and supported by the bevel pinion housing, carries the inner end of the axle shafts in the internally splined differential wheels which are mounted on taper roller bearings in the bevel pinion housing. The bevel pinion is adjusted for bearing pre-load and correct positioning by shims. When the bevel pinion is adjusted correctly the only other adjustment required is the backlash setting of the crown wheel, this is effected by rotating the serrated nuts at each side of the differential bearings (Fig 3).

Operation

4 Drive is transmitted from the propeller shaft to the bevel pinion, then to the crown wheel, from the crown wheel to the differential casing and pinions, then to the differential wheels and the axle shafts.

Lubrication

5 The differential is oil lubricated, having a filler/level plug fitted at the rear of the axle casing and an oil drain plug fitted to the underside of the casing. Breathing is achieved through a banjo connection in the top of the casing and is passed to the engine compartment via plastic tubing.

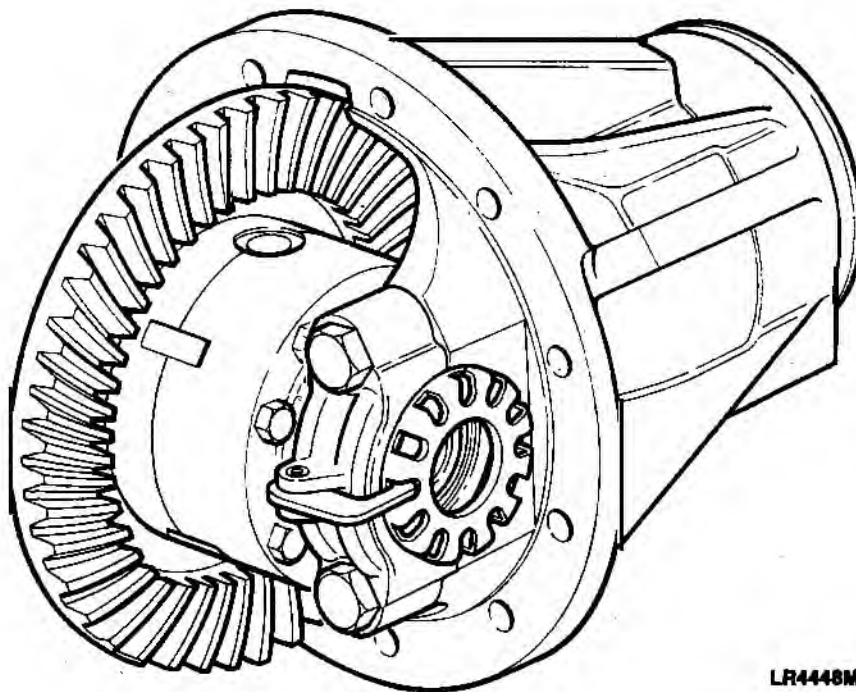


Fig 3 Differential assembly

Digitized by Google

Chapter 6

FRONT AXLES

TECHNICAL DESCRIPTION

INTRODUCTION

1 This Chapter gives the technical descriptions for front axles fitted to Land Rover 2.5 litre diesel 90 and 110 vehicles, and Land Rover 3.5 litre petrol 110 and 127 vehicles.

2 The Chapter has been Sub-chaptered as follows to accommodate the front axle fitted to Land Rover 2.5 litre diesel 90 and 110 vehicles, and the front axle fitted to Land Rover 3.5 litre petrol 110 and 127 vehicles.

Chapter 6-1 FRONT AXLE 2.5 LITRE DIESEL 90 AND 110

Chapter 6-2 FRONT AXLE 3.5 LITRE PETROL 110 AND 127

General

3 The information given is applicable to both left and right hand drive vehicles.

Chapter 6-1
FRONT AXLE 2.5 litre diesel 90 and 110

CONTENTS

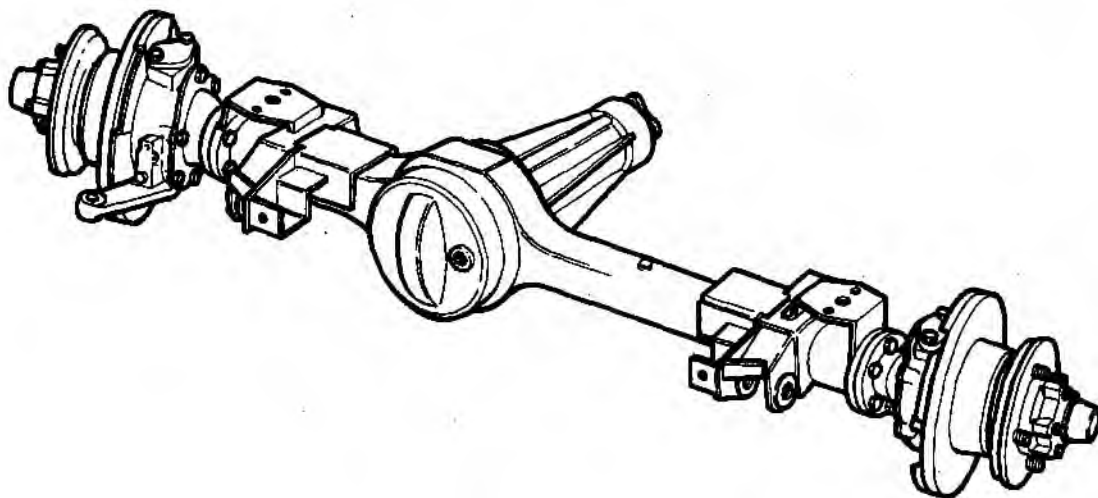
Frame	Para		Page
	1	Introduction	
	2	Description	
	5	Operation	
	6	Lubrication	
Fig			Page
	1	Front axle assembly	1
	2	Differential assembly	2
	3	Stub axle and swivel assembly	3
	4	Front hub assembly	4

INTRODUCTION

1 This chapter covers the technical description for front axles as fitted to Land Rover 90 and 110 vehicles.

Description

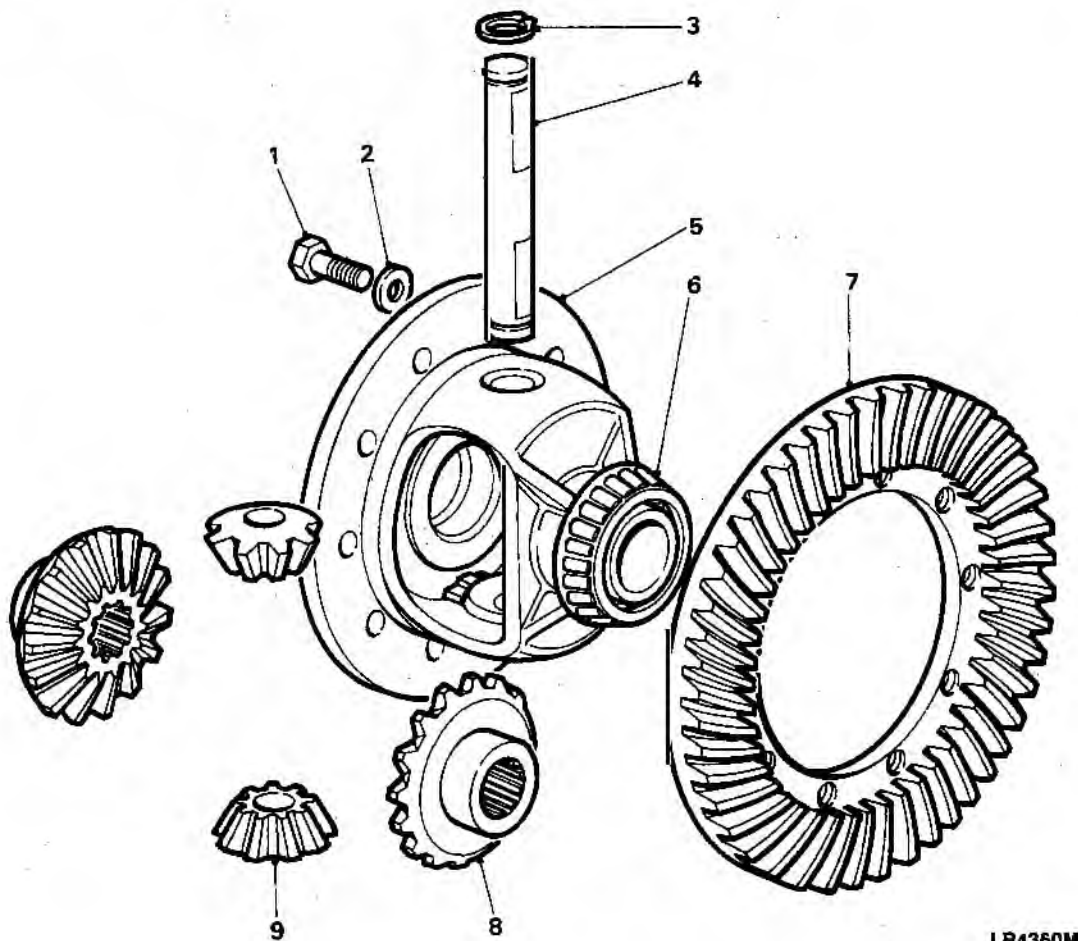
2 The front axle (Fig 1) is of the fully floating type with the differential off-set to the right hand side.



LR4433M

Fig 1 Front axle assembly

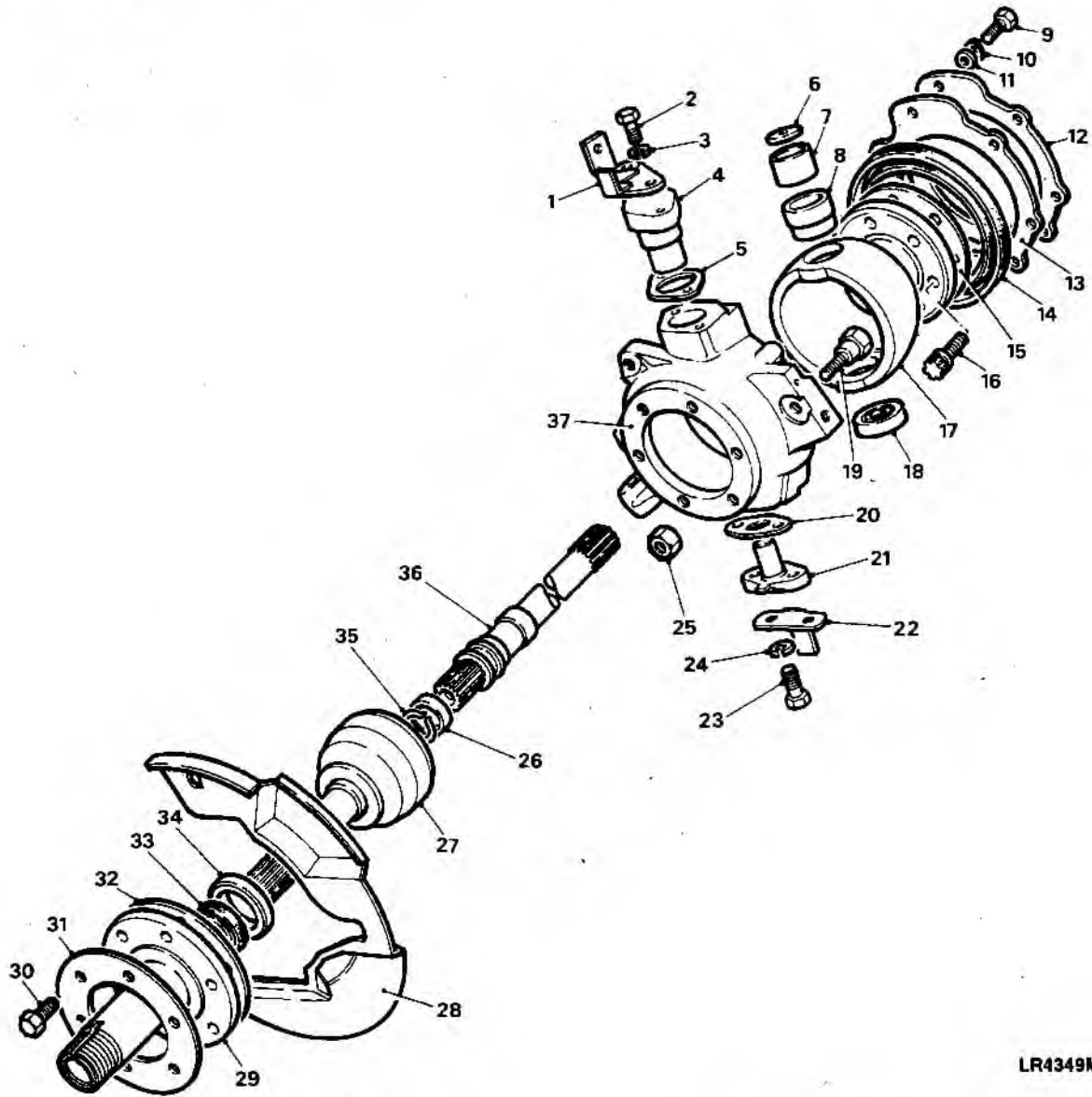
3 A standard Land Rover differential is fitted to the front axle, having a one piece differential case with an integral crown wheel, two pinions rotating on a single shaft transfer the drive from the crown wheel to the differential wheels. The differential wheels have internal splines which carry the inner ends of the axle shafts (Fig 2). The bevel pinion and its housing are identical to the heavy duty differential fitted to the rear axle.



- | | | | |
|---|----------------------|---|-------------------|
| 1 | Bolt | 6 | Carrier bearing |
| 2 | Washer | 7 | Crown wheel |
| 3 | Circlip | 8 | Differential gear |
| 4 | Cross shaft | 9 | Pinion gears |
| 5 | Differential housing | | |

Fig 2 Differential assembly

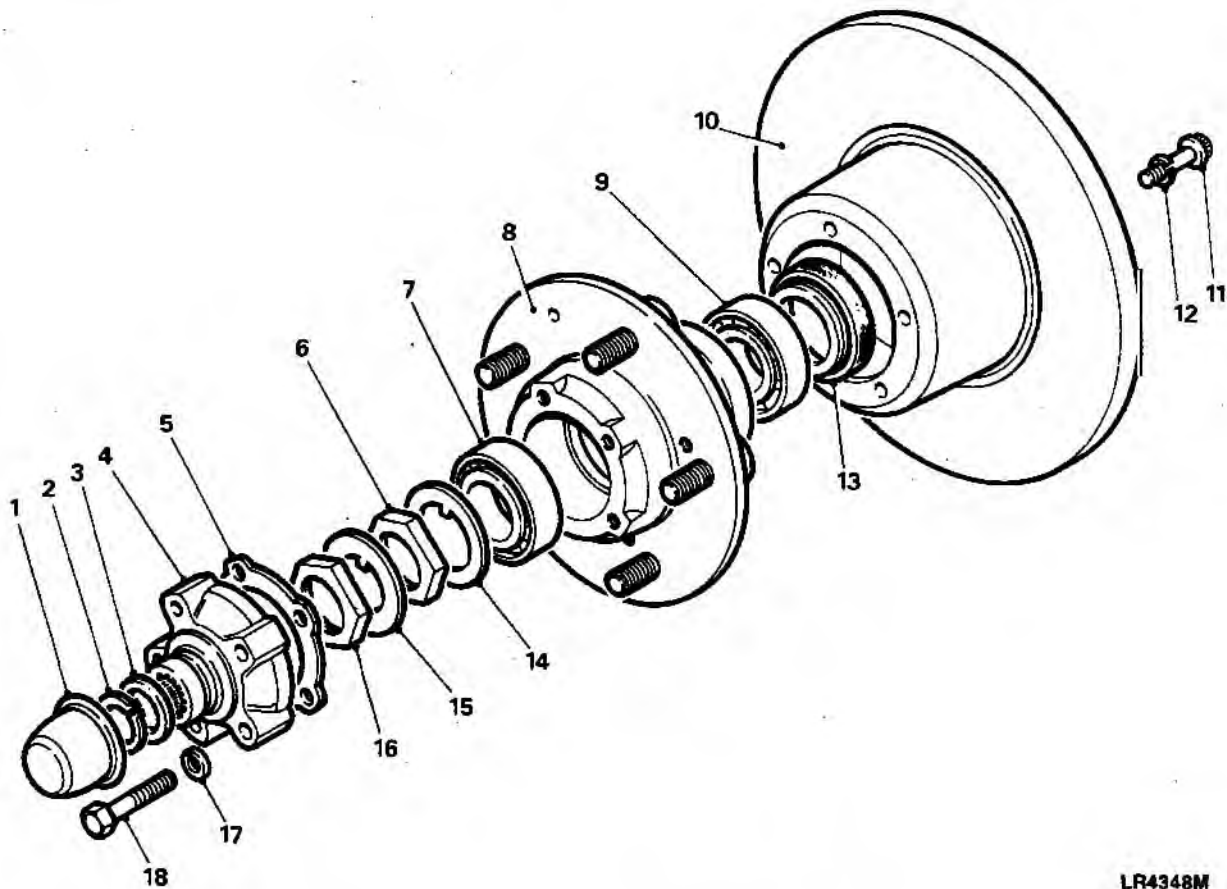
4 The outer ends of the axle shafts are splined to constant velocity joints housed within swivel pin assemblies (Fig 3). Bolted to the outer housing of the swivel assemblies are stub axles, in which are located the stub axle shafts, the latter being coupled to the main axle shafts by the constant velocity joints. The wheel hubs are carried on taper roller bearings mounted on the stub axles, drive members having a splined fit to the stub axle shafts are secured to the hub by bolts. Gaiters are fitted to the rear of the swivels to give added protection during off-road working.



LR4349M

- | | | | |
|----|----------------------------|----|---------------------------|
| 1 | Bracket brake hose | 20 | Gasket |
| 2 | Bolt | 21 | Lower swivel pin |
| 3 | Spring washer | 22 | Bracket brake disc shield |
| 4 | Upper swivel pin | 23 | Bolt |
| 5 | Shim | 24 | Spring washer |
| 6 | Thrust disc | 25 | Steering lock stop nut |
| 7 | Railko bush | 26 | Collar |
| 8 | Railko bush housing | 27 | Constant velocity joint |
| 9 | Bolt | 28 | Brake disc shield |
| 10 | Spring washer | 29 | Stub axle |
| 11 | Plain washer | 30 | Bolt |
| 12 | Oil seal retaining plate | 31 | Mud shield |
| 13 | Gasket | 32 | Gasket |
| 14 | Oil seal | 33 | Oil seal |
| 15 | Gasket | 34 | Bush |
| 16 | Bolt | 35 | Circlip |
| 17 | Swivel pin bearing housing | 36 | Axle shaft |
| 18 | Lower swivel pin bearing | 37 | Swivel pin housing |
| 19 | Steering lock stop bolt | | |

Fig 3 Stub axle and swivel assembly



LR4348M

1	Dust cap	10	Brake disc
2	Circlip	11	Bolt
3	Shim	12	Spring washer
4	Driving member	13	Oil seal
5	Gasket	14	Key washer
6	Adjusting nut	15	Lock washer
7	Outer bearing	16	Lock nut
8	Hub	17	Spring washer
9	Inner bearing	18	Bolt

Fig 4 Front hub assembly

Operation

5 Drive to the front axle shafts is transmitted in the same manner as to the rear axle shafts, then by means of the constant velocity joints to the stub axle shafts, driving members and wheel hubs.

Lubrication

6 The swivel pin assemblies are oil lubricated and fitted with filler/level and drain plugs. Lubrication of the differential assembly is the same as for the rear axle.

Chapter 6-2

FRONT AXLE 3.5 LITRE PETROL 110 AND 127

TECHNICAL DESCRIPTION

CONTENTS

Para.

- FRONT AXLE
1 Introduction
2 Description
5 Operation
6 Lubrication

Fig.

- 1 Front axle assembly
2 Differential assembly
3 Stub axle and swivel assembly
4 Front hub assembly

Page

- 1
2
3
5

FRONT AXLE

INTRODUCTION

1 This chapter covers the technical description for front axles fitted to Land Rover 3.5 litre petrol 127 vehicles, and for V8 110 vehicles see Chapter 6-1.

DESCRIPTION

2 The front axle (Fig 1) is of the fully floating type with the differential off-set to the right hand side.

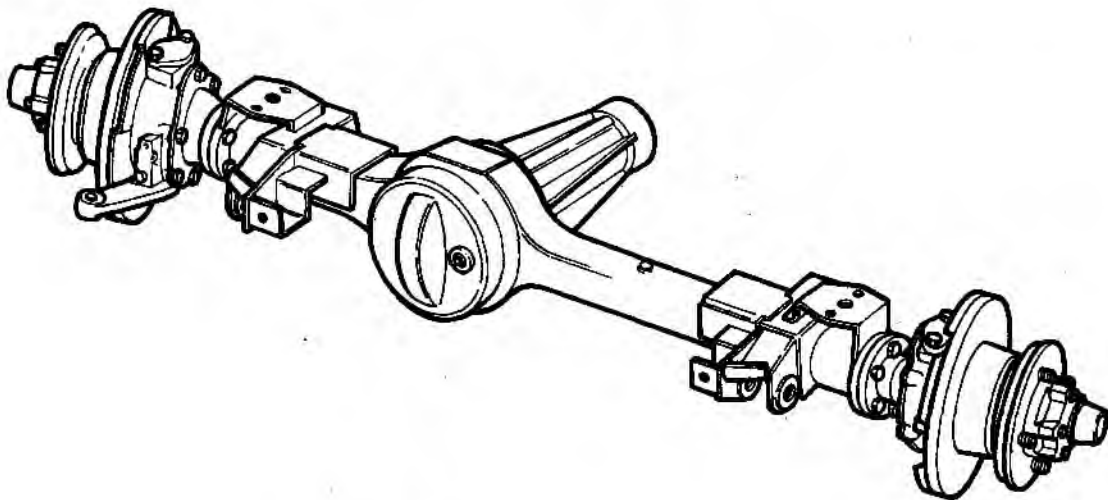


Fig 1 Front axle assembly

3 The differential case assembly complete with crown wheel, differential pinions and wheels, mounted on taper roller bearings and supported by the bevel pinion housing, carries the inner end of the axle shafts in the internally splined differential wheels which are mounted on taper roller bearings in the bevel pinion housing. The bevel pinion is adjusted for bearing pre-load and correct positioning by shims. When the bevel pinion is adjusted correctly the only other adjustment required is the backlash setting of the crown wheel, this is effected by rotating the serrated nuts at each side of the differential bearings (Fig 2).

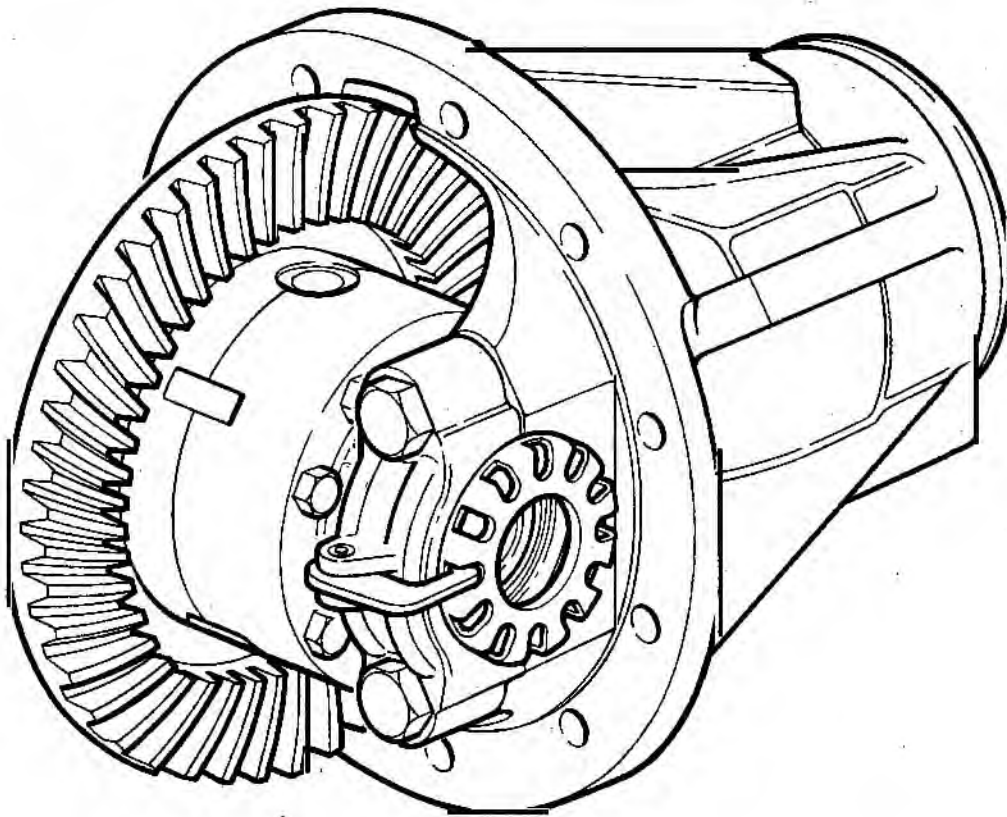
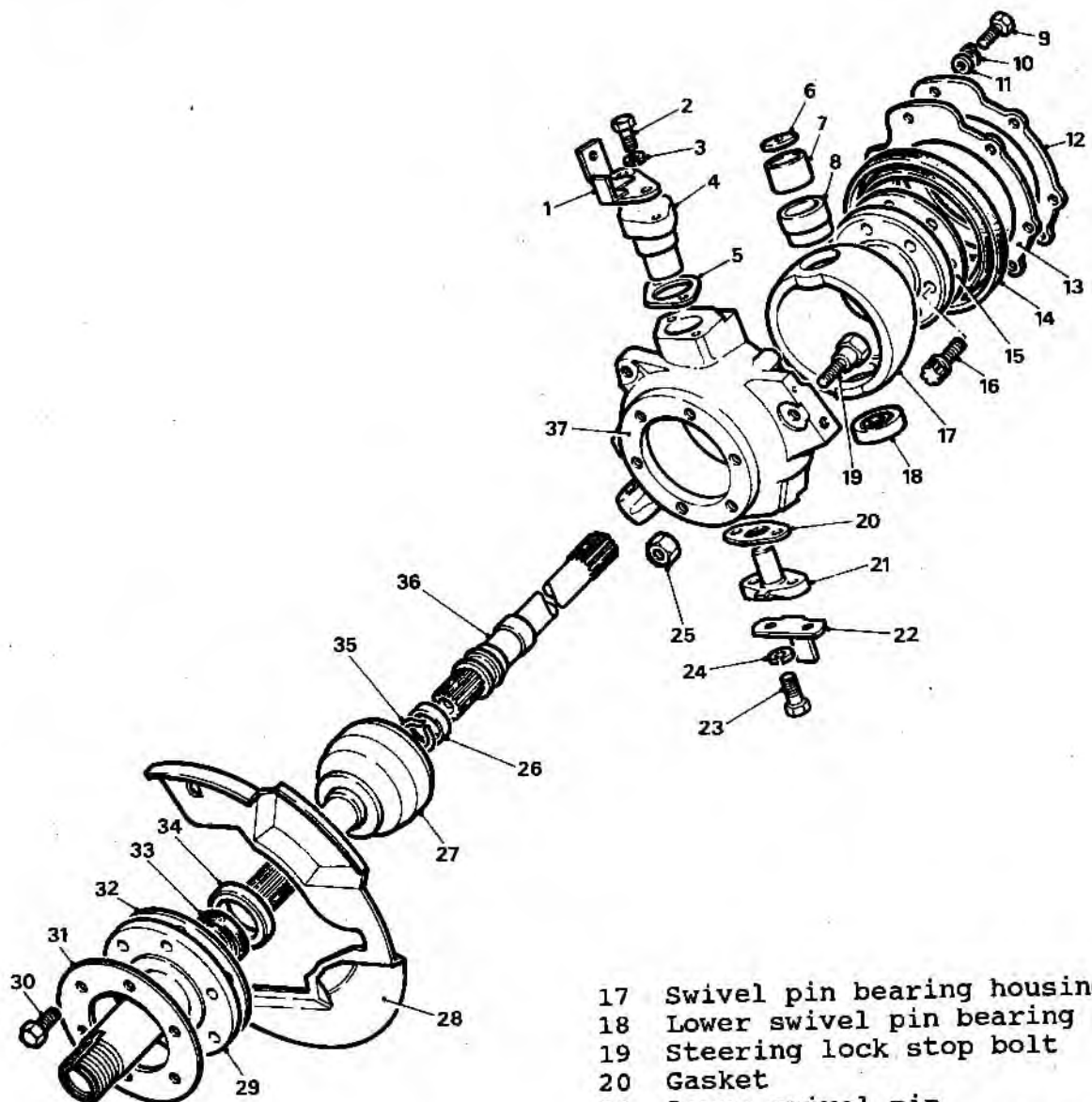


Fig 2 Differential assembly (127 Vehicles Only)

4 The outer ends of the axle shafts are splined to constant velocity joints housed within swivel pin assemblies (Fig 3). Bolted to the outer housing of the assemblies are stub axles, in which are located the stub axle shafts, the latter being coupled to the main axle shafts by the constant velocity joints. The wheel hubs are carried on taper roller bearings mounted on the stub axles, drive members having a splined fit to the stub axle shafts are secured to the hub by bolts. Gaiters are fitted to the rear of the swivels to give added protection during off-road working.



- 1 Bracket brake hose
- 2 Bolt
- 3 Spring washer
- 4 Upper swivel pin
- 5 Shim
- 6 Thrust disc
- 7 Railko bush
- 8 Railko bush housing
- 9 Bolt
- 10 Spring washer
- 11 Plain washer
- 12 Oil seal retaining plate
- 13 Gasket
- 14 Oil seal
- 15 Gasket
- 16 Bolt

- 17 Swivel pin bearing housing
- 18 Lower swivel pin bearing
- 19 Steering lock stop bolt
- 20 Gasket
- 21 Lower swivel pin
- 22 Bracket brake disc shield
- 23 Bolt
- 24 Spring washer
- 25 Steering lock stop nut
- 26 Collar
- 27 Constant velocity joint
- 28 Brake disc shield
- 29 Stub axle
- 30 Bolt
- 31 Mud shield
- 32 Gasket
- 33 Oil seal
- 34 Bush
- 35 Circlip
- 36 Axle shaft
- 37 Swivel pin housing

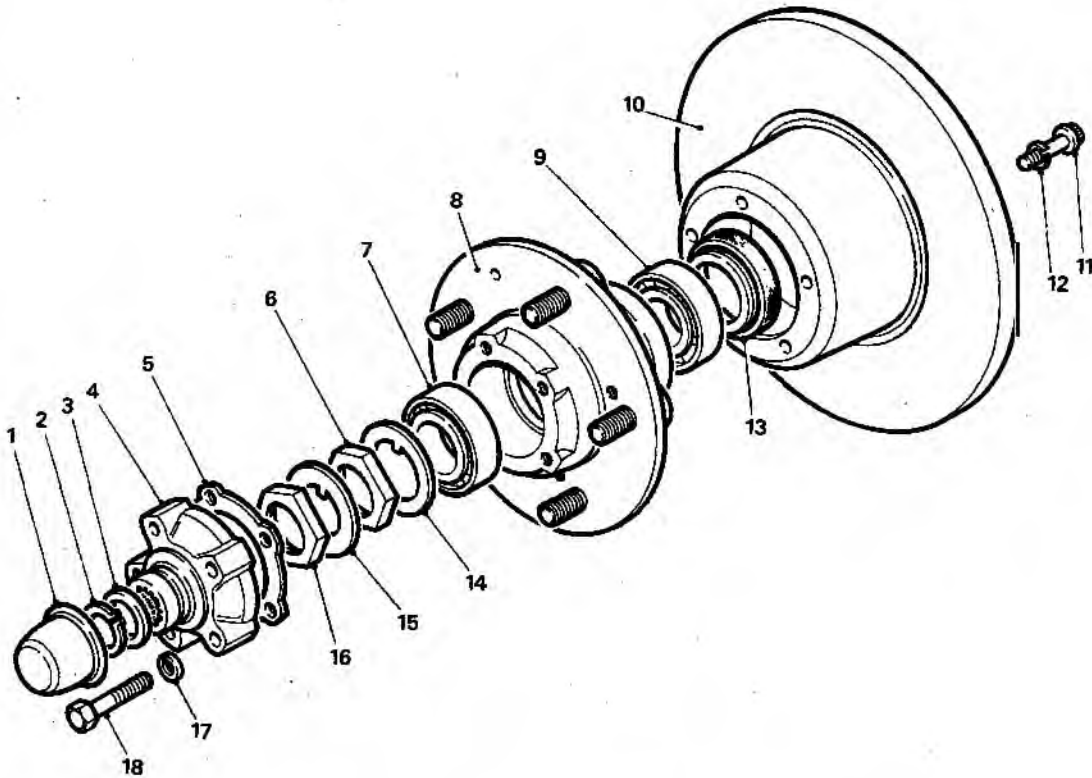
Fig 3 Stub axle and swivel assembly

OPERATION

5 Drive to the front axle shafts is transmitted from the transfer box to the differential via a prop shaft. The drive is then transmitted from the differential via drive shafts, constant velocity joints, stub axle shafts, driving members to wheel hubs.

LUBRICATION

6 The swivel pin assemblies are oil lubricated and fitted with filler/level and drain plugs. Lubrication of the differential assembly is the same as for the rear axle.



- | | | | |
|---|----------------|----|---------------|
| 1 | Dust cap | 10 | Brake disc |
| 2 | Circlip | 11 | Bolt |
| 3 | Shim | 12 | Spring washer |
| 4 | Driving member | 13 | Oil seal |
| 5 | Gasket | 14 | Key washer |
| 6 | Adjusting nut | 15 | Lock washer |
| 7 | Outer bearing | 16 | Lock nut |
| 8 | Hub | 17 | Spring washer |
| 9 | Inner hub | 18 | Bolt |

Fig 4 Front hub assembly

Chapter 7

STEERING SYSTEMS

TECHNICAL DESCRIPTION

INTRODUCTION

1 This Chapter gives the technical description for steering systems fitted to Land Rover 90 and 110 vehicles, and the power steering system fitted to Land Rover 3.5 litre petrol 127 vehicles.

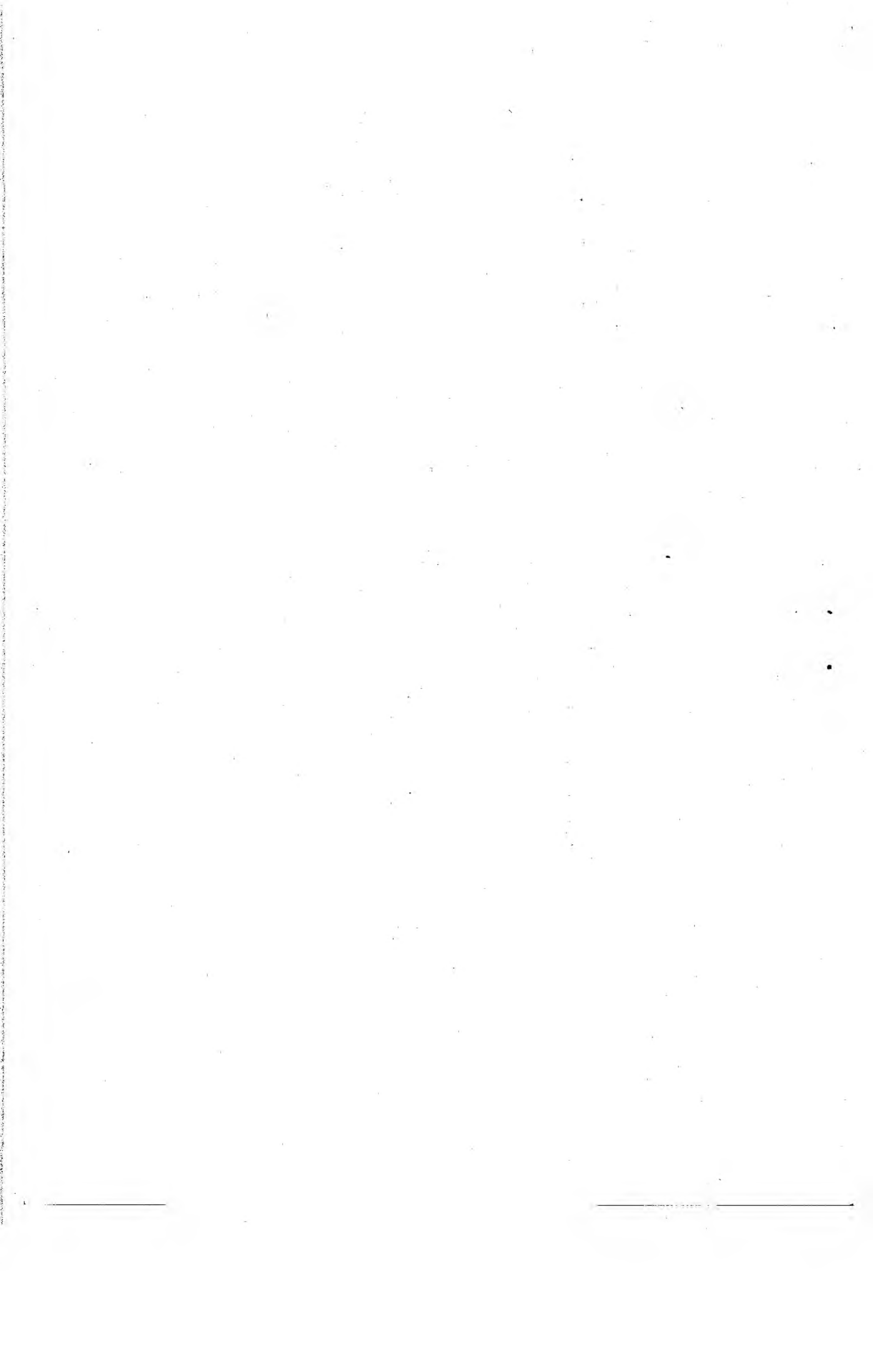
2 The Chapter has been Sub-chaptered as follows to accommodate the various systems fitted.

Chapter 7-1 STEERING SYSTEM 90 AND 110 VEHICLES

Chapter 7-2 POWER STEERING SYSTEM 127 VEHICLES

General

3 The information given is applicable to both left and right hand drive vehicles.



Chapter 7-1

STEERING SYSTEM 90 AND 110 VEHICLES

CONTENTS

Frame	Para		Page
	1	Introduction	
	2	Description	
	5	Operation	
	Fig		
	1	Steering system	2

INTRODUCTION

1 This chapter covers the manual steering system as fitted to Land Rover 90 and 110 vehicles.

Description

2 The manual steering system (Fig 1) incorporates a non-adjustable steering column conforming to the latest safety standards.

3 The linkage from the steering column to the steering box is by an angled rod with universal joints at each end. The linkage is fitted with a metallastic safety coupling which, in the event of the vehicle receiving a severe frontal impact, prevents the steering column from being forced back towards the driver. The metallastic rubber also absorbs a certain amount of the everyday road shocks transmitted through the system.

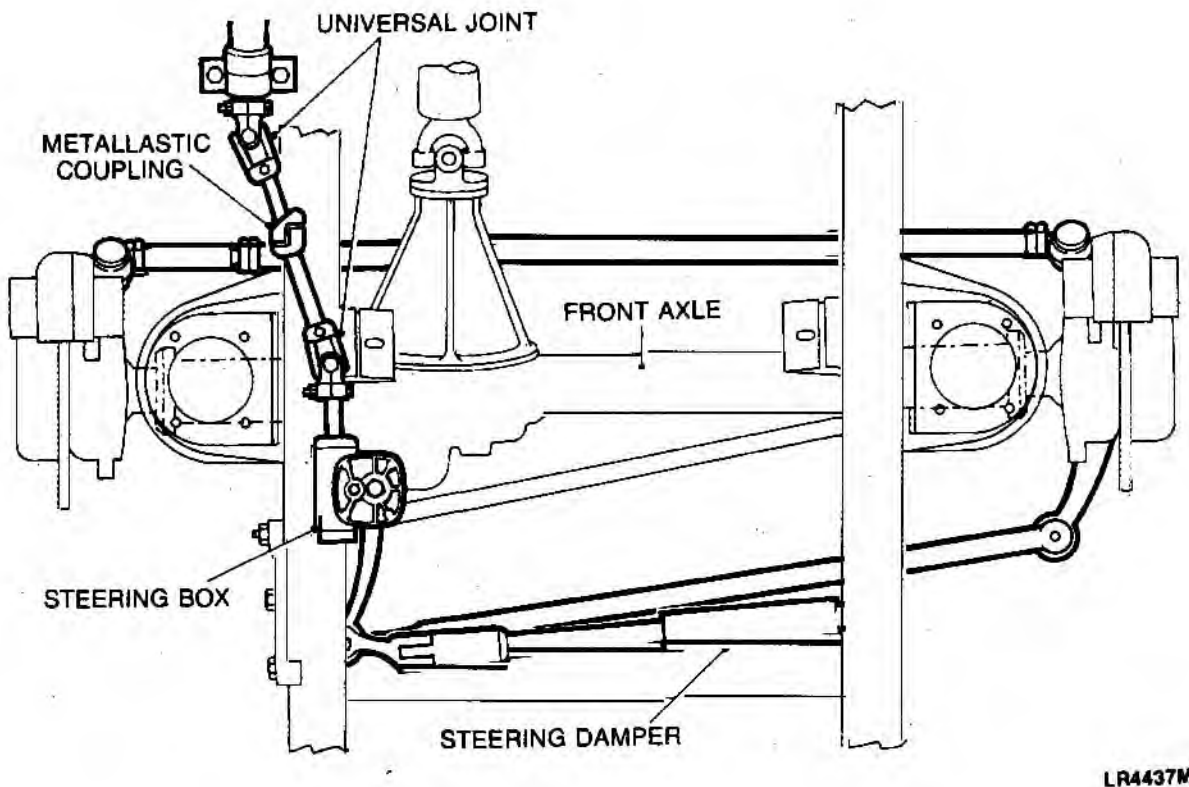
4 The steering box is mounted on the inner face of the chassis side member to the rear of the second cross member so that its position protects it from any possible damage when the vehicle is operating off road. The steering box is stabilised by a strut from the base of the box to the panhard rod mounting bracket.

Operation

5 The steering box converts the rotary motion of the steering wheel to a reciprocating (side to side) motion of the steering linkage and provides the driver with the extra leverage he needs to steer the road wheels. The positive steering 'feel' and reduced 'kick back' are achieved by using a hour glass worm and roller design in the steering box

6 At the bottom end of the steering wheel shaft a coarse screw thread is formed. The 'Hour-glass' shape of this threaded section is engaged with a Vee-shaped roller, attached to the drop arm/steering linkage. When the steering wheel is turned the threaded section moves the roller up or down the thread, turning the drop arm right or left.

7 A steering damper, operating in a similar manner to a shock absorber, is mounted horizontally between the chassis and the steering drag link. This is a double acting damper, retaining 'feel' by giving little resistance to light shocks and steering movement, but absorbing violent road shocks.



LR4437M

Fig 1 Steering system

Chapter 7-2

POWER STEERING SYSTEM 127 VEHICLES

CONTENTS

Frame	Para		Page
	1	Introduction Steering system	
	2	General	
	3	Steering box	
	4	Pump	
	6	Operation	
Fig			Page
	1	Power steering arrangement	2
	2	Steering box	3/4

INTRODUCTION

1 This chapter details the technical description for the power steering system fitted to Land Rover 3.5 litre V8 petrol 127 vehicles.

STEERING SYSTEM

General

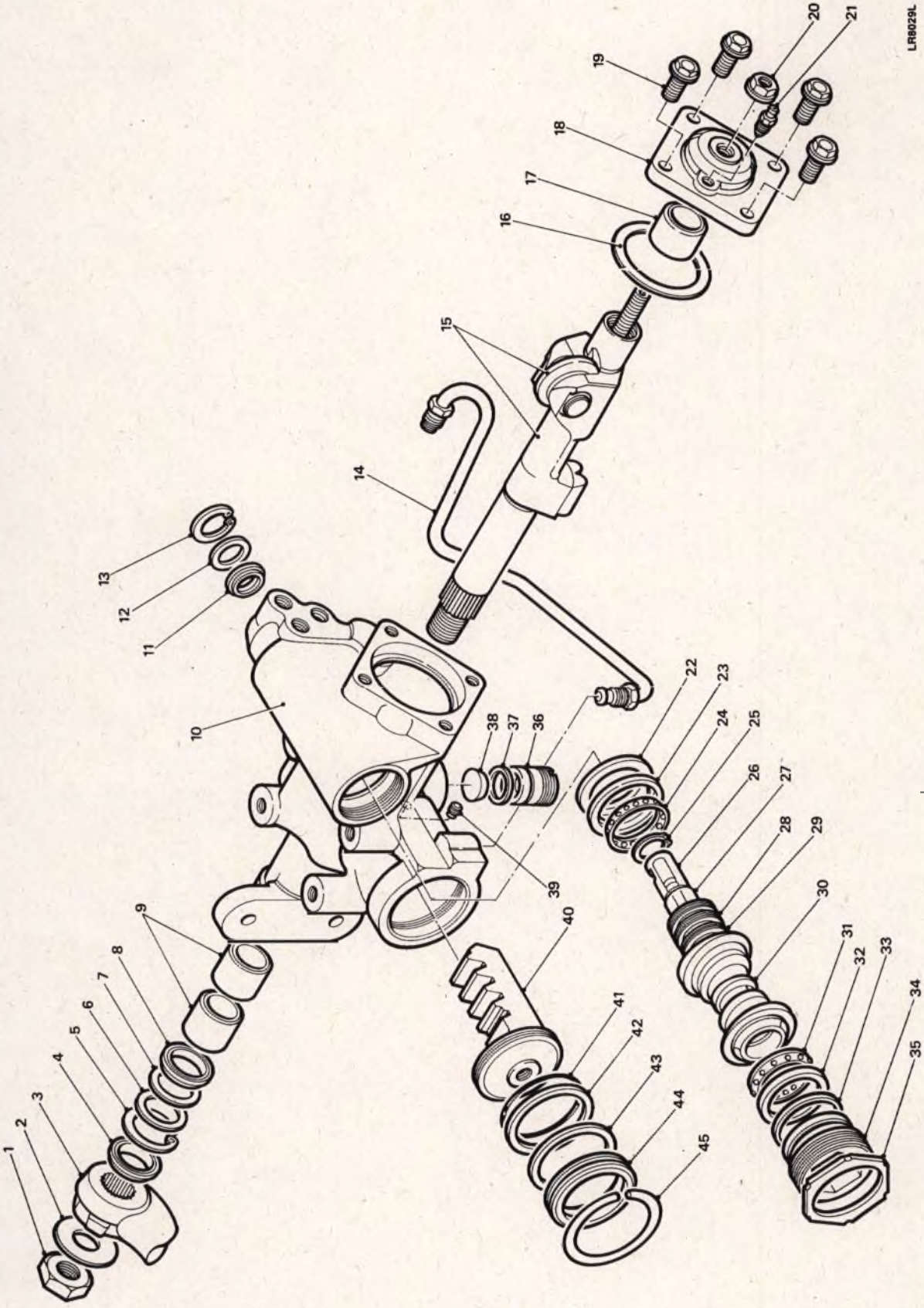
2 The power steering system consists of three major components. A belt driven pump (Fig 1 (2)) is mounted to the engine front face and supplies hydraulic power to the chassis mounted power steering box (4). A top-up reservoir (1) mounted to the inner seam of the r.h. outer wing enables maintenance of the system fluid level. Both the steering pump and box are serviceable items.

Steering Box

3 The power assisted steering box consists of three main sub-assemblies. A valve and worm assembly (Fig 2 (22 -35)), sector shaft and follower assembly (1-21) and rack and piston assembly (40-45).

Pump

4 The power steering hydraulic pump is a conventional rotary type secured to the engine front face via an adjustable bracket. A belt, driven direct from the crankshaft pulley provides the pumps rotary motion.



LR8029L

Steering box

Operation

5 Steering action is transferred to the steering box from the steering column via a universal joint and worm assembly. Rotary motion of the worm (Fig 2 (30)) acts directly on the sector shaft follower (15), transmitting the steering action to the drop arm (3). Steer assistance is provided by a hydraulically loaded piston and rack (40), acting directly on the shaft quadrant.

6 High pressure steering fluid is delivered from the pump (Fig 1 (2)) to the steering box (4) via a feed line (3). The fluid is then circulated via a line (6) to the fluid reservoir (1) and back through a return line (5) to the pump.

Note ...

The fluid reservoir contains an integral filter which is not serviceable, however in normal use the reservoir should last the life of the vehicle. Should the power steering system malfunction, and under inspection it is found that the steering fluid has been contaminated by foreign matter a new fluid reservoir must be fitted.

7 Steering action is transmitted from the steering box sector shaft to the drop arm and then through mechanical linkage to the roadwheels.

Chapter 8

SUSPENSION

INTRODUCTION

1 This Chapter gives a technical description of the suspensions as fitted to Land Rover 90/110 vehicles and the Land Rover 127 vehicles.

2 The Chapter has been Sub-chaptered to allow for the eventuality of other types of Land Rover suspensions.

List of Sub-Chapters

Chapter 8-1 SUSPENSION 90/110 VEHICLES

Chapter 8-2 SUSPENSION 127 VEHICLES (HEAVY DUTY)

3 The information is applicable to both right and left hand drive vehicles.

Chapter 8-1

SUSPENSION 90/110 VEHICLES

CONTENTS

Frame	Para		Page
	1	Introduction	
	2	General	
	3	Coil springs and dampers	
	9	Front axle	
	11	Rear axle	
Fig			Page
	1	Front suspension	2
	2	Rear suspension	3

INTRODUCTION

1 This chapter covers the suspension system as fitted to Land Rover 90 and 110 vehicles.

General

2 Both the Land Rover 90 and 110 vehicles feature a simple suspension design of beam axles with long, low rate coil springs, assisted by two stage hydraulic dampers. This combination absorbs on and off-road wheel shocks and deflections, thereby reducing body roll. The design allows maximum articulation of both axles, to keep the wheels constantly in contact with the ground for maximum traction and safety.

Coil springs and dampers

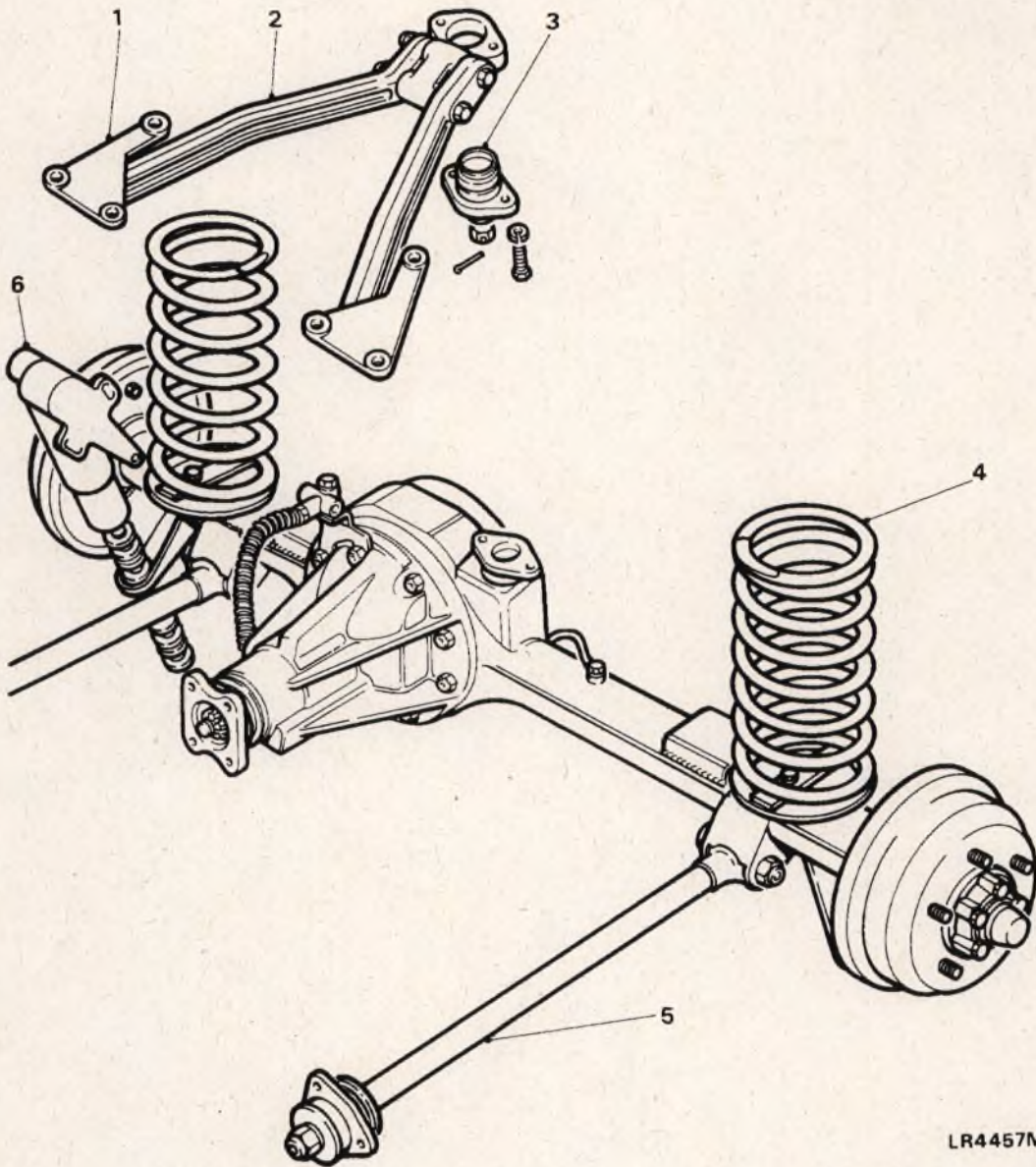
3 The coil spring is effectively a coiled torsion bar which stores energy produced by the up and down movement of the vehicle. The telescopic damper (shock absorber) damps out vibrations so that the springs do not continually bounce up and down.

Spring rates

4 Progressive rate coil springs are fitted to the front axle of all Land Rover 110 models. These springs have a primary rate of 27.1 N mm (155 lbf in) for unladen or lightly laden conditions, increasing to 36,95 N mm (211 lbf in) as the load is built up to the maximum permissible payload. The long two stage shock absorbers act in a similar way to the springs. They provide soft resistance to light shocks or suspension movements on normal road surfaces and a harder, faster acting resistance to counteract more violent off road movements, preventing any build up of spring oscillation.

5 The coil springs fitted to the rear axle have a single rate of 57.8 N mm (330 lbf in). The shock absorbers, mounted at a forward angle to the axle, are also two stage and operate in the same way as the front.

6 All coil springs are handed, either right or left, being slightly longer on the drivers side in order to maintain a lateral level attitude when being driven unladen.



LR4457M

- | | | | |
|---|--------------------------|---|----------------|
| 1 | Chassis mounting bracket | 4 | Road spring |
| 2 | Upper link assembly | 5 | Lower link |
| 3 | Pivot ball-pin assembly | 6 | Shock absorber |

Fig 2 Rear suspension

Chapter 8-2

SUSPENSION 127 VEHICLES (HEAVY DUTY)

TECHNICAL DESCRIPTION

1 For details of the technical description for the heavy duty suspension fitted to Land Rover 127 vehicles, refer to Cat 522 Chap 8-2 Para 2 and 3.

Chapter 10
BRAKING SYSTEM
CONTENTS

Frame	Para		Page
	1	Introduction	
		Description	
	2	General	
	5	Master cylinder	
	7	Servo unit	
	8	Land Rover 90	
	9	Land Rover 110	
	Fig		
	1	Master cylinder fluid chambers	2
	2	Section through servo unit	3
	3	Schematic of Land Rover 90 brake hydraulic system	4
	4	Schematic of Land Rover 110 brake hydraulic system	5
	5	Valve connections	6

INTRODUCTION

1 This chapter covers the technical description for the braking systems fitted to Land Rover 90 and 110 vehicles.

DESCRIPTION

General

2 The mechanical components of the braking system consist leading/trailing shoe drum brakes, each operated by a single cylinder double acting hydraulic cylinder at the rear of the vehicle and four piston caliper disc brakes at the front. The cable controlled hand brake is a mechanically operated single drum brake mounted on the output shaft of the transfer gearbox and is completely independent of the main braking system.

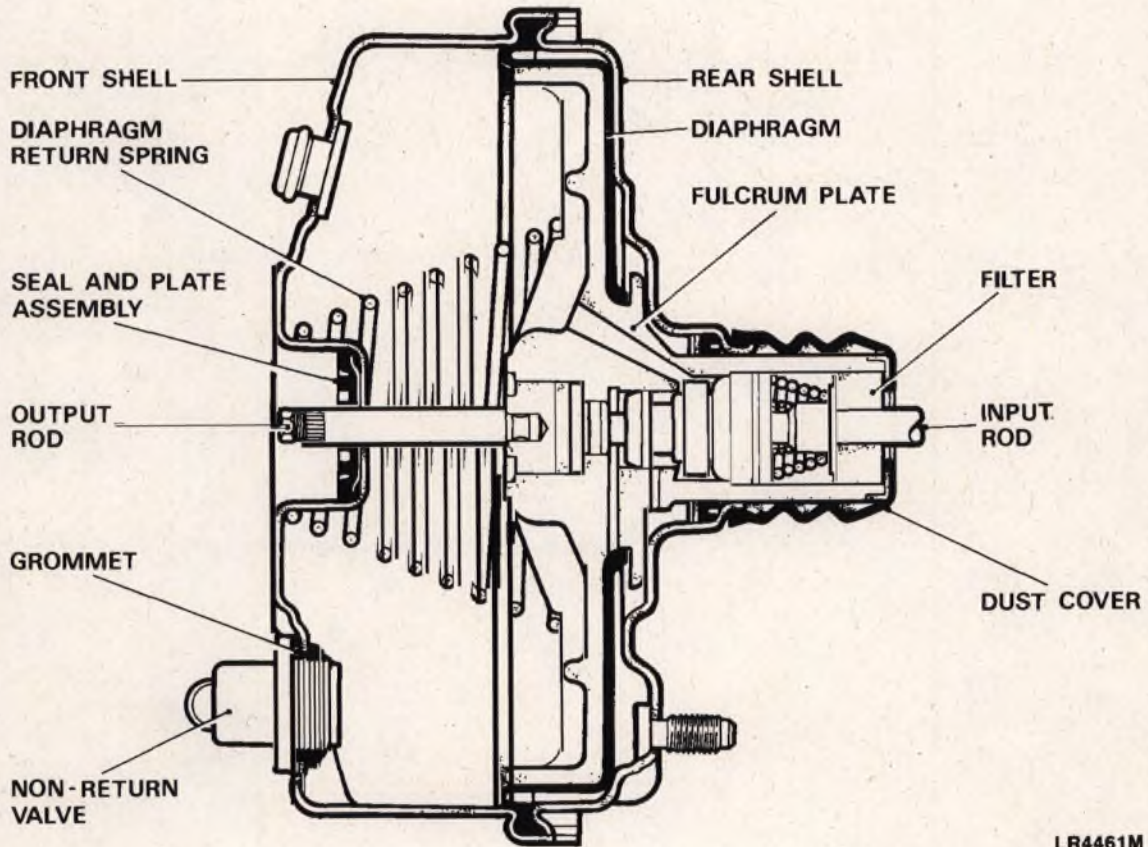
3 Adjustment of the rear wheel drum brakes is by a snail cam turned by a hexagon head on the back-plates. The transmission drum brake is adjusted by means of an expander assembly.

4 The basic hydraulic system involves two separate and independent primary and secondary circuits which permit a degree of braking should a fault occur in one of the circuits. The primary circuit operates the rear brakes and the secondary circuit controls the front brake calipers. The tandem master cylinder, which is assisted by a direct acting servo, is fed by a divided fluid reservoir. Fluid contained in the rear section of the reservoir supplies the primary circuit whilst that in the front portion supplies the secondary circuit.

6 When the brakes are released, the plungers, aided by the return spring, are retracted faster than the fluid, this creates a vacuum between the fluid in chambers 'A' and 'C' and the recuperation seals. The recuperation seals momentarily collapse allowing fluid in chambers 'B' and 'D', which is unaffected by the movement of the plungers, to flow through the hole in the plungers, over the collapsed seals and into chambers 'A' and 'C' respectively. The movement of fluid from one set of chambers to the other, is compensated for by fluid from the separate reservoirs in the supply tank moving through the feed holes in the cylinder. Conversely, the final return movement of the plungers causes the extra fluid in chambers 'A' and 'C' to move through the cut off holes into the fluid reservoirs.

Servo unit

7 The servo unit is a mechanical device which provides controlled power assistance to the brake pedal when pressure is applied. Power supplied by the unit is obtained from a vacuum pump located on the diesel engine of the vehicle. The vacuum is applied to both sides of a flexing diaphragm and by admitting atmospheric pressure to the rear of the diaphragm, the power is obtained. The servo unit is mounted between the brake pedal and the master cylinder and is connected to these assemblies by push rods. Should a vacuum failure occur, the two push rods will act as a single rod allowing the brakes to work in the conventional manner; but more effort will be required to operate the brake pedal.

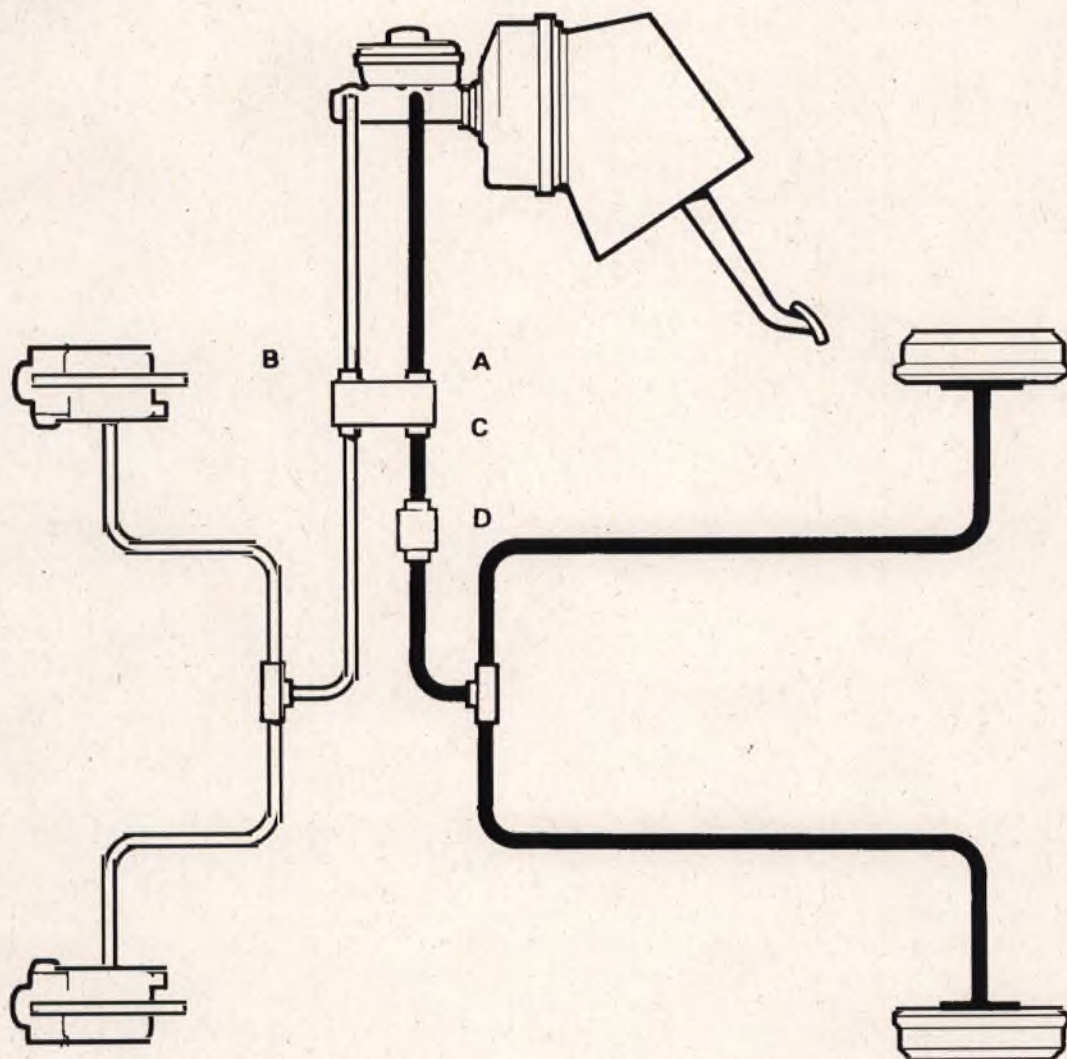


LR4461M

Fig 2 Section through servo unit

Land Rover 110

9 Land Rover 110 models have a Pressure Differential Warning Actuator Valve (P D W A Valve) situated between the master cylinder and the front and rear brakes. The valve is bolted to the bulkhead within the engine compartment. An electrical switch incorporated within the valve is wired to a lamp on the drivers warning light panel. The lamp illuminates momentarily when the starter is actuated, indicating that the brake warning circuit is functioning correctly. A fault in either the primary or secondary circuits is evident if the warning lamp illuminates upon application of the foot brake while the engine is running. Should a pressure failure occur in the front brake circuit (secondary) the piston in the P D W A valve will move in the direction of the failed circuit causing the switch to operate and the lamp to illuminate. At the same time full fluid pressure in the primary circuit to the rear brakes will continue. The P D W A valve will function in a similar manner should a failure occur in the primary, rear brake circuit. Illumination of the lamp at any time other than initial starting should always be investigated immediately. A 'G' pressure sensitive valve is also fitted to the primary circuit.



LR4438M

- | | | | |
|---|-----------------|---|------------------------|
| A | Primary circuit | B | Secondary circuit |
| C | PDWA valve | D | GPS apportioning valve |

Fig 4 Schematic of Land Rover 110 brake hydraulic system

Chapter 11

FUEL SYSTEMS

TECHNICAL DESCRIPTION

INTRODUCTION

1 This Chapter gives a Technical Description of the fuel systems as fitted to Land Rover 90 and 110 vehicles having 2.5 Litre naturally aspirated diesel engines and Land Rover 110 and 127 vehicles having 3.5 Litre V8 standard and derated engines.

2 The chapter has been Sub-chaptered as follows to accomodate the fuel systems fitted to both the 2.5 Litre naturally aspirated diesel engines and the 3.5 Litre V8 petrol engines.

Chapter 11-1 DIESEL FUEL SYSTEM

Chapter 11-2 PETROL FUEL AND EXHAUST SYSTEM

Chapter 11-3 PULSAIR SYSTEM (DERATED ENGINES)

3 The information is applicable to both right and left hand drive vehicles.

Chapter 11-1

DIESEL FUEL SYSTEM

CONTENTS

Frame	Para		Pag
	1	Introduction	
	2	General	
	3	Operation	
	4	Fuel tanks	
	5	Fuel filler	
	6	Fuel sedimenter	
	8	Fuel lift pump	
	9	Fuel filter	
		Fuel injection pump	
	10	General	
	11	Description	
	20	Operation	
	32	Fuel injectors	
	35	Air cleaner	
	36	Heater plugs	
	Fig		
	1	Land Rover 90 fuel pipe lay-out	2
	2	Land Rover 110 fuel pipe lay-out	3
	3	Section through sedimenter	4
	4	Fuel lift pump	5
	5	Fuel filter	6
	6	DPS Pump mounted to engine	7
	7	Pump housing, drive shaft assembly and hydraulic head	8
	8	DPS pump controls	9
	9	Governor control linkage	10
	10	Layout of fuel system	12
	11	Exploded view of fuel injector	13

INTRODUCTION

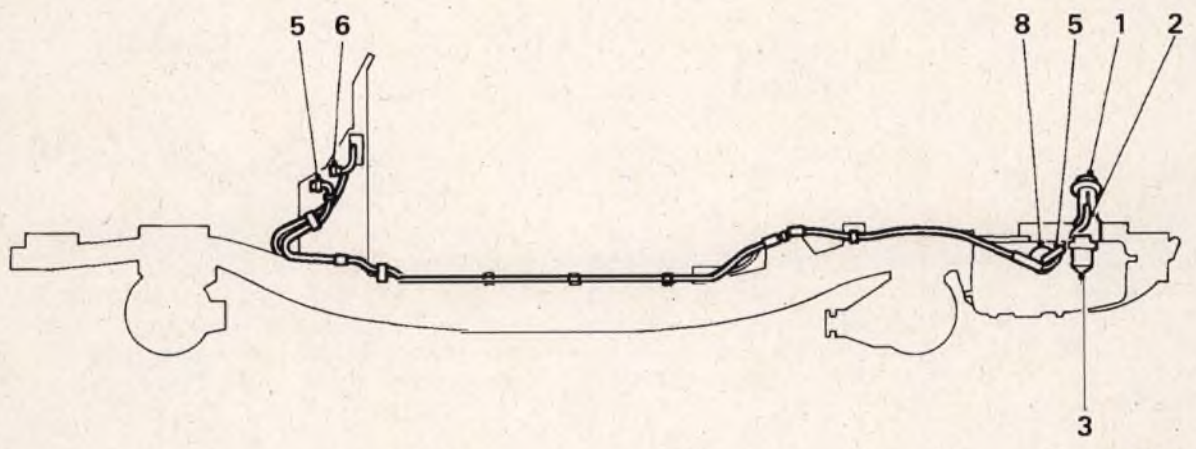
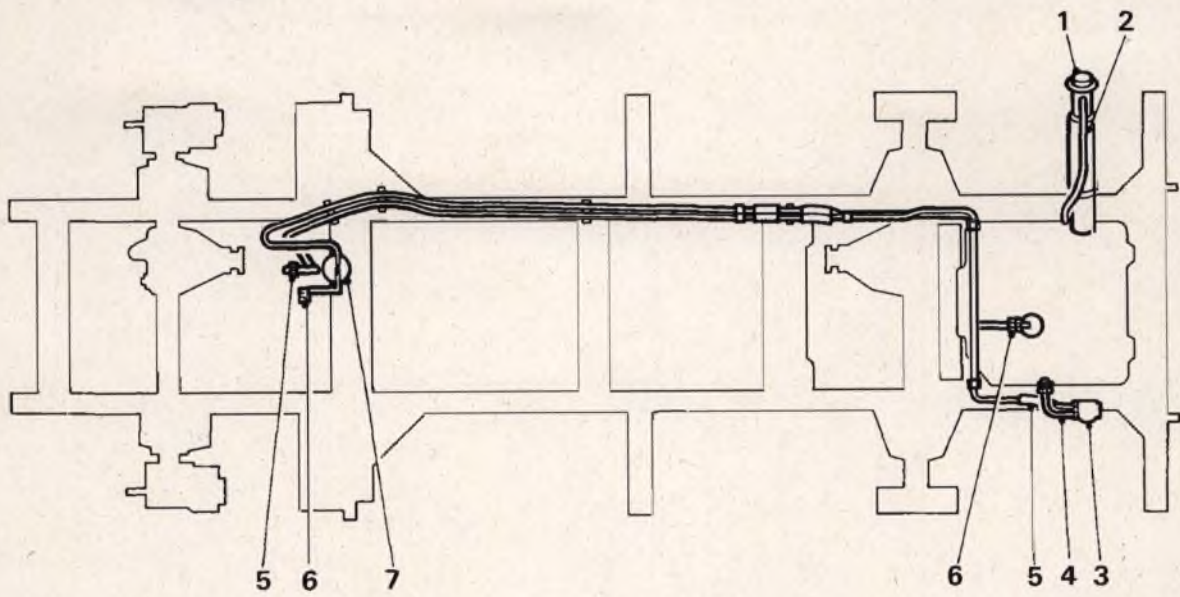
1 This chapter covers the diesel fuel system as fitted to Land Rover 90 and 110 vehicles.

General

2 The fuel system for Land Rover 90 and 110 vehicles, having 2.5 litre non-turbo diesel engines, is identical except for the position of the fuel tank. The system consists of a fuel tank, fuel supply line, fuel sedimenter, fuel lift pump, fuel filter, fuel injection pump, fuel injectors and an air cleaner.

Operation

3 Fuel is drawn from the tank, by the fuel lift pump, via the sedimenter. The fuel flows from the lift pump through the fuel filter to the injection pump from which it is metered to the injectors. Some of the fuel is returned to the fuel filter via a one-way pressure valve. Clean air flows to the intake manifold via the air cleaner.



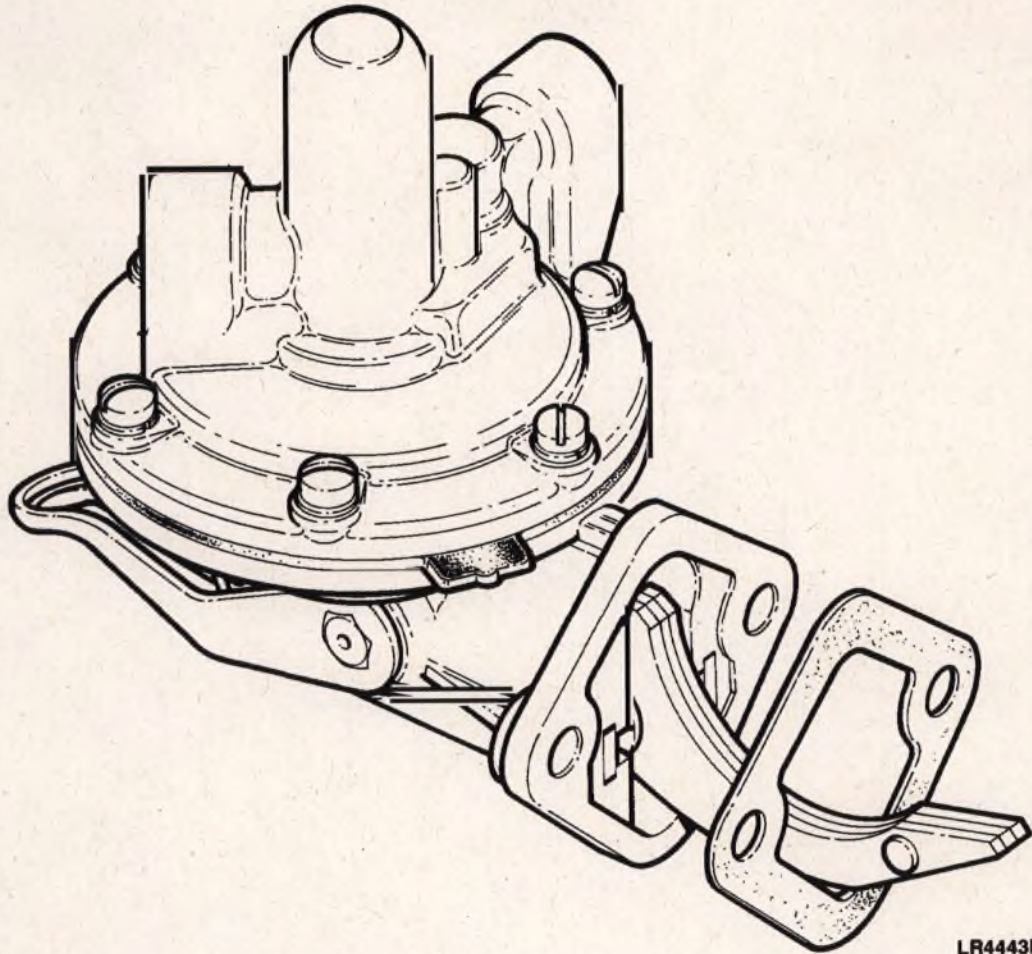
LR4440M

- | | |
|-----------------------------|---------------------------------------|
| 1 Fuel filler | 5 Supply sedimenter to fuel lift pump |
| 2 Breather pipe | 6 Injector leak-off and filter vent |
| 3 Sedimenter | 7 Fuel filter |
| 4 Supply tank to sedimenter | 8 Fuel tank gauge unit |

Fig 2 Land Rover 110 fuel pipe lay-out

Fuel filler

5 The fuel filler is located on the right hand side of the vehicle, on the Land Rover 90 it is forward of the rear wheel arch, on the Land Rover 110 it is toward the rear of the vehicle between the rear wheel arch and the back of the vehicle. To assist with fuel filling from a jerry can, a telescopic neck with an integral filter is incorporated. The fuel tank is vented to atmosphere via a double acting relief valve integral with the filler cap; the filler cap also has a facility to be secured with a padlock.

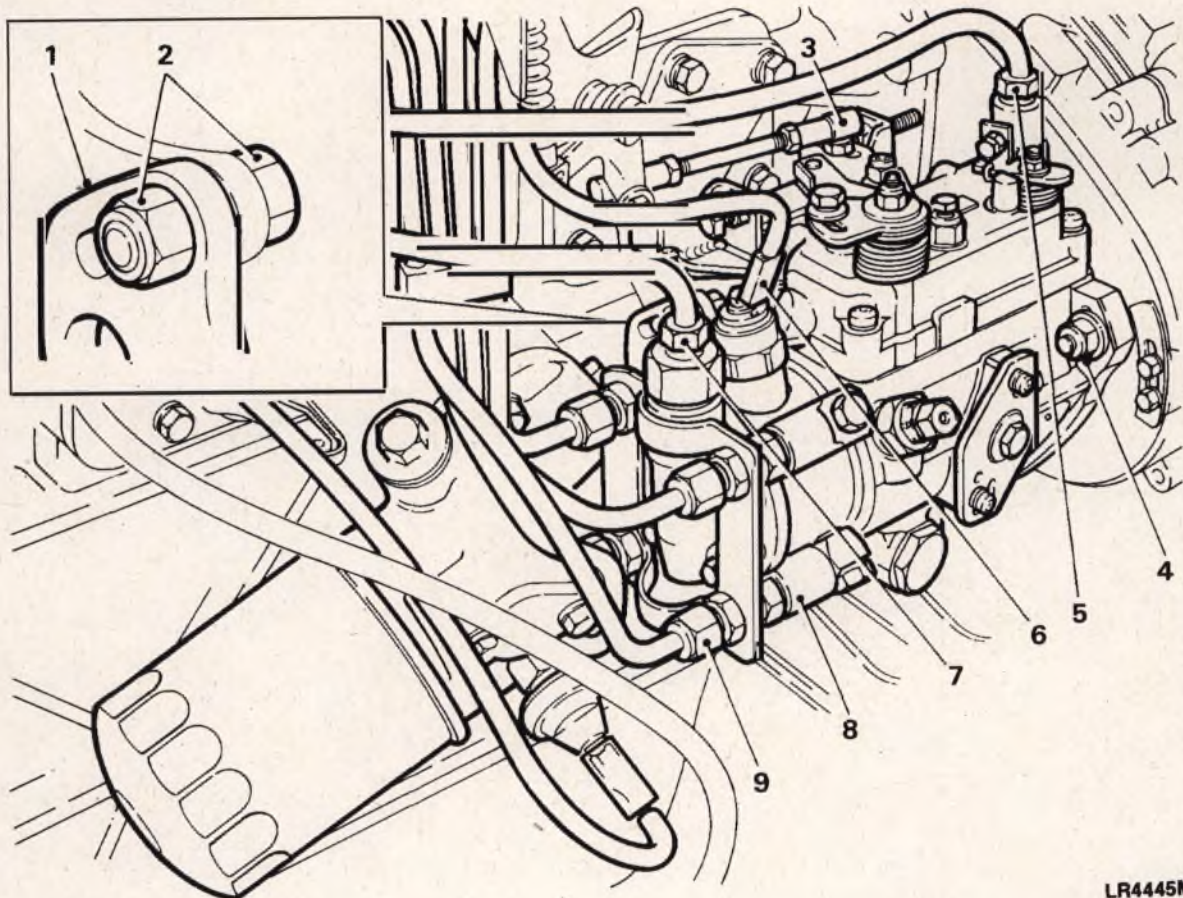


LR4443M

Fig 4 Fuel lift pump

Fuel filter

9 The fuel filter (Fig 5) is situated at the rear of the engine secured to the bulkhead and is of the agglomerator flow type, the internal circuit is designed to separate the fine water droplets from the emulsion of water and fuel which have not been removed by the sedimenter. A drain plug incorporated in the bottom cover allows water to be drained off. The filter consists of a head unit, bottom cover and a filter element, the outer casing of the element being utilized as the filter body.



LR4445M

- | | | | |
|---|-------------------------|---|--------------------------------|
| 1 | Support bracket | 6 | Solenoid electrical connection |
| 2 | Nut and bolt | 7 | Fuel inlet pipe |
| 3 | Ball-pin throttle lever | 8 | Delivery valves |
| 4 | Securing nuts | 9 | Fuel feed pipes |
| 5 | Return to filter | | |

Fig 6 DPS Pump mounted to engine

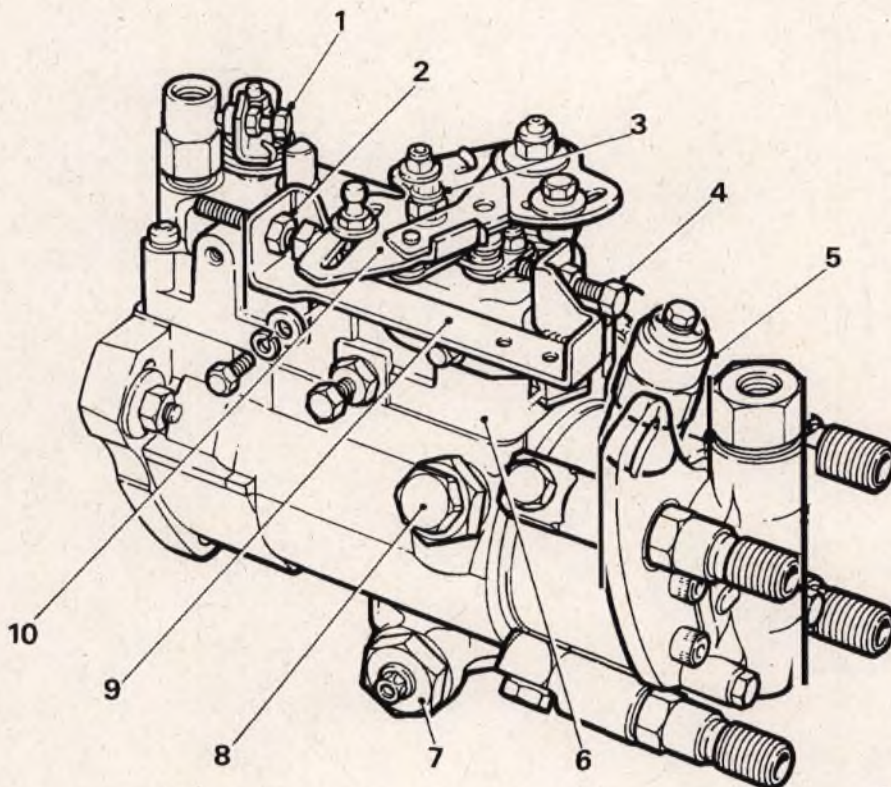
12 The pump has a solid one-piece drive shaft (Fig 7 (11)). Rollers (14) and shoes (15) are contained within the shaft assembly and the associated pumping forces are therefore transmitted directly from the pump drive gear. This effectively eliminates all backlash points between the driving and driven members. The one piece design also allows the front and rear bearings (28) to be located wide apart at each end of the shaft minimising the wear from side loads imposed by the belt drive.

13 The fuel is supplied to a vane type transfer pump (20) via the inlet connection and regulating valve. The regulating valve controls transfer pressure to a metering valve which is operated by the throttle lever and regulates the flow of fuel to the filling ports of the rotor. The distributor rotor (23) carries a pair of opposed high pressure pumping plungers (24) which under the action of fuel at filling pressure, push the rollers (14) into contact with the internal lobes of a pair of scroll plates (25 and 27) during the filling part of the cycle.

14 Maximum fuelling is pre-set by a sealed external adjuster which controls the scroll plates located concentrically with and either side of the cam ring (26). These act as check plates, limiting the outward movement of the rollers and can be partially rotated to adjust maximum fuelling.

16 The latch and rotor vent switch valves are located on either side of the pump housing and connect with passages in the hydraulic head (Fig 7 (21)). The latch valve, at engine cranking speed, ensures that the transfer pressure does not reach the auto-advance unit until the engine has self sustained. The rotor vent switch valve (Fig 8 (8)) performs the separate function of venting any air trapped between the pump plungers through a vent orifice in the hydraulic head. The valve thus provides the rotor with a self priming capability enabling an easy re-start to be made without bleeding the pump should the vehicle run out of fuel. When the engine self-sustains, transfer pressure opens the latch valve diverting the fuel under pressure to the advance device and simultaneously to the rotor vent valve, thus closing the vent passage to the cam box.

17 A two speed mechanical governor fitted with a 'cush drive' weight retainer (Fig 7 (6)) controls engine speed at idling and maximum only. At intermediate speeds there is a direct link between the metering valve and the accelerator pedal. Idling speed can be set independently of the throttle stop position by a variable idle control lever (Fig 8 (1)).



LR4446M

- | | | | |
|---|----------------------------|----|--------------------------|
| 1 | Idling lever | 6 | Governor control cover |
| 2 | Anti-stall screw (pre-set) | 7 | Auto-advance unit |
| 3 | Vent screw | 8 | Rotor vent switch valve |
| 4 | Maximum speed screw | 9 | Throttle control bracket |
| 5 | Shut-off solenoid | 10 | Throttle lever |

Fig 8 DPS Pump controls

Operation

19 Fuel at feed pressure (Fig 10 (E)) passes into the transfer pump (11) which raises the pressure with increasing engine speed to an intermediate value termed transfer pressure (B) controlled by the regulating valve (10). In operation the regulating valve maintains a pre-determined relationship between speed of rotation and transfer pressure by returning part of the fuel to the inlet side of the transfer pump.

20 Fuel at transfer pressure (B) is supplied to the pumping plungers and via a separate passage, actuates the latch valve (13). To fill the plungers, fuel at transfer pressure (B) flows around annular grooves in the hydraulic head (12) and passes via a solenoid shut-off valve (6) into a drilling in the top of the hydraulic head sleeve. Fuel then flows to the metering valve (5), which regulates fuel flow through linkage to the accelerator pedal or movement of the governor weights (19).

21 As fuel passes through the metering valve orifice, in the hydraulic head, a pressure drop occurs reducing transfer pressure (B) to a level known as metering pressure (C). Fuel from the metering valve then passes into two oblique filling ports via a circular groove in the sleeve to the rotor charging ports, then through a central drilling in the rotor to fill the opposed pumping plungers. These are then actuated by the internally lobed cam ring to pump the fuel at injector pressure.

22 The cam ring lobes are phased with the drillings in the hydraulic head and rotor which allows alternate filling and injection. The rotor ports first charge the pumping plungers at metered pressure (C), then fuel is pumped from the distributor port at injection pressure (A) to each of the injectors (16) in turn.

23 A controlled leakage of fuel for lubricating and cooling purposes passes between the rotor, hydraulic head, plungers and bore etc., and then to the cam box.

24 Cam box pressure (F) is maintained by the fuel being returned via a one-way to the fuel filter where the pressure is maintained at fuel lift pump pressure. The filter vent flow is returned to the fuel tank through a 0,50 mm orifice connection together with the back leakage flow from the injectors.

25 To activate the latch valve (13), fuel at transfer pressure (B), regulated by pump speed, flows into a drilling in the bottom of the hydraulic head sleeve and, via an annular groove in the sleeve, to the latch valve.

26 At cranking speeds, the latch valve is closed and prevents fuel at transfer pressure (B) flowing either to the advance unit or the rotor vent switch valve (18). The vent switch valve is spring loaded to the open position allowing fuel and air from the rotor to be vented to the cam box.

27 At a pre-determined pressure, i.e. above cranking speed the latch valve opens to allow fuel at transfer pressure (B) to flow via an annular groove in the hydraulic head sleeve to the head locating fitting (16). Fuel from the head locating fitting flows to the underside of the stem of the rotor vent switch valve lifting the valve and closing the rotor vent passage to the cam box. Fuel also flows from the head locating fitting to the pressure side of the piston of the automatic advance unit (15).

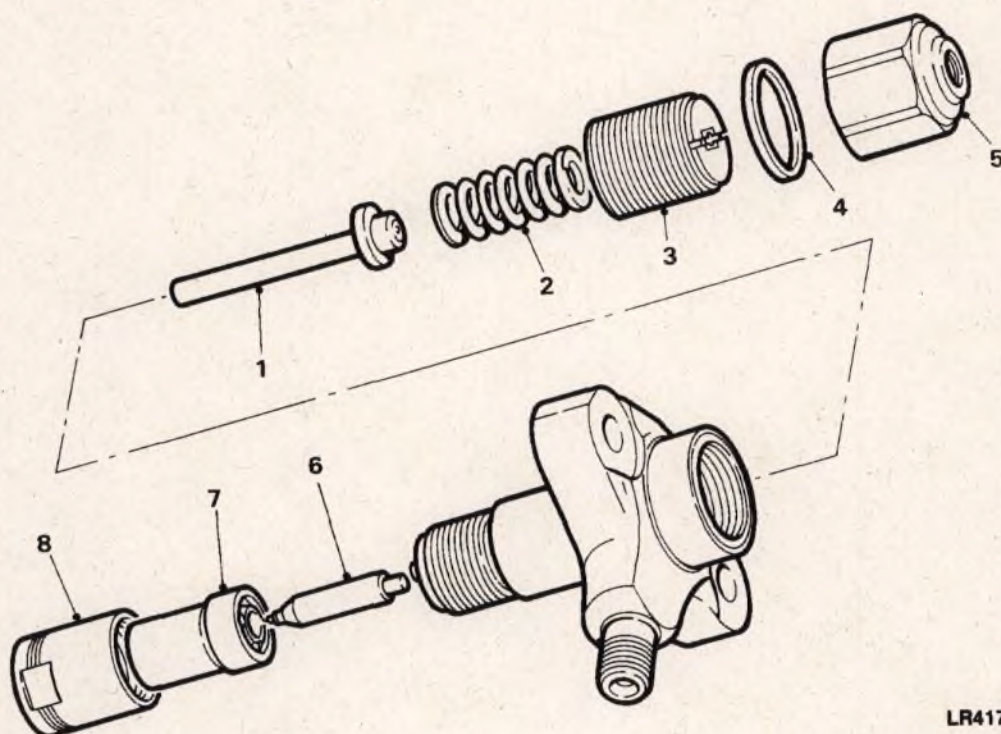
28 With an increase in pump speed, transfer pressure (B) acting on the advance piston causes the cam ring to advance the injection timing. Leakage from the advance unit flows back to the cam box.

Fuel injectors

29 The fuel injectors (Fig 11) are made up from two major parts. The nozzle assembly, through which fuel is injected into the combustion chamber and the nozzle holder, which locates the nozzle, carries the spring which controls the nozzle opening pressure, allows the assembly to be fitted in the cylinder head and provides the fuel inlet connection.

30 Fuel entering the injector passes through galleries in the body and nozzle to a chamber surrounding the nozzle valve. The valve is held tightly closed by the valve spring until on the fuel pump injection stroke, fuel pressure rises above the pre-set spring pressure. The valve then lifts, permitting the high pressure fuel to pass through and spray from the nozzle tip. At the end of the injection stroke the fuel pressure falls, the spring returns the valve to its seat and the spray into the combustion chamber is terminated.

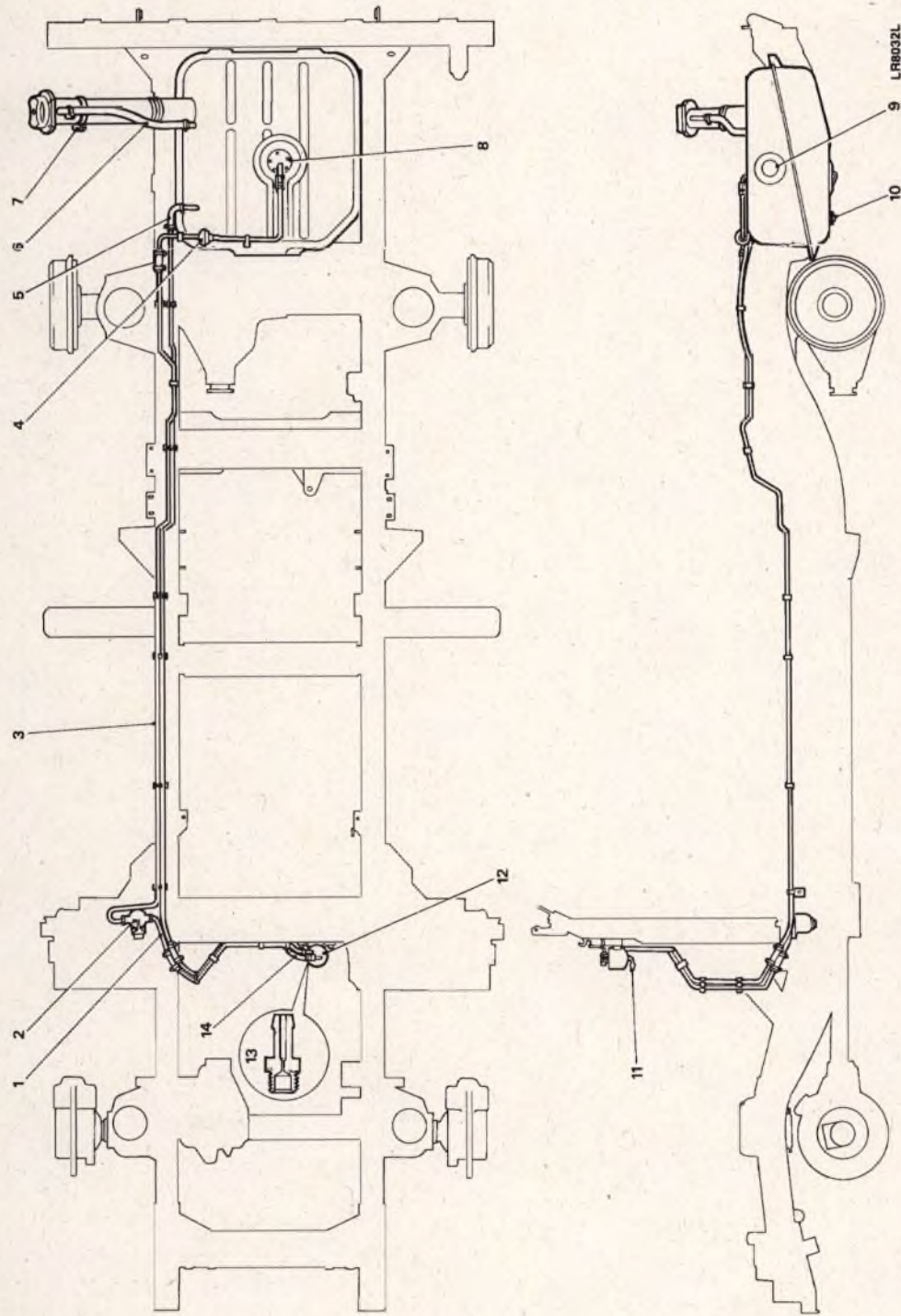
31 Fuel is used as a lubricant for the moving parts of the injectors; after carrying out this function the fuel is returned, via a small bore pipe to connect with the filter vent and return to the fuel tank.



LR4173M

- | | | | |
|---|-----------------|---|--------------|
| 1 | Valve spindle | 5 | End cap |
| 2 | Pressure spring | 6 | Nozzle valve |
| 3 | Adjusting screw | 7 | Nozzle body |
| 4 | Sealing washer | 8 | Cap nut |

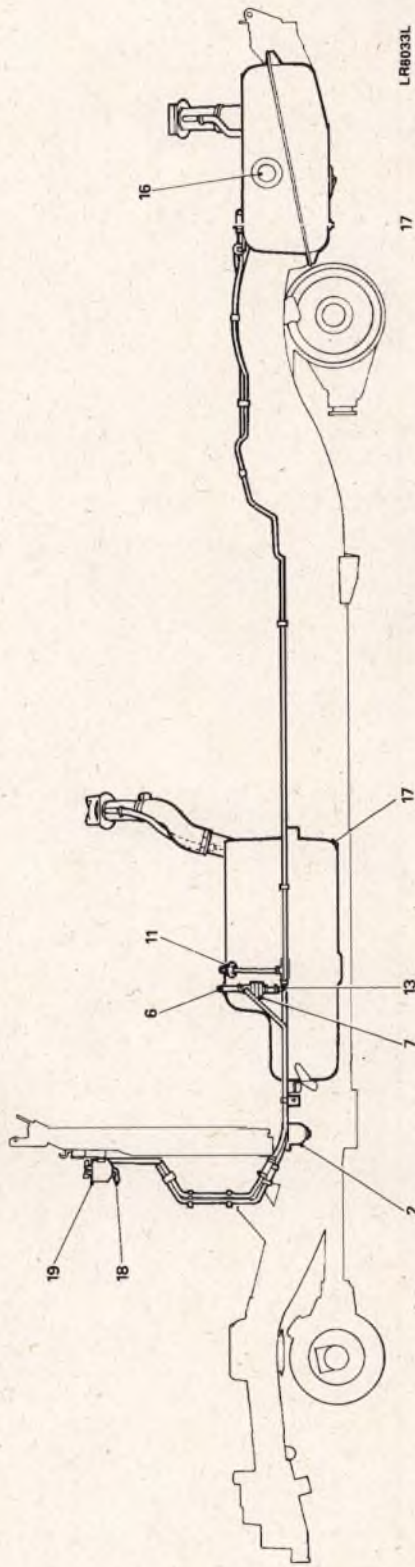
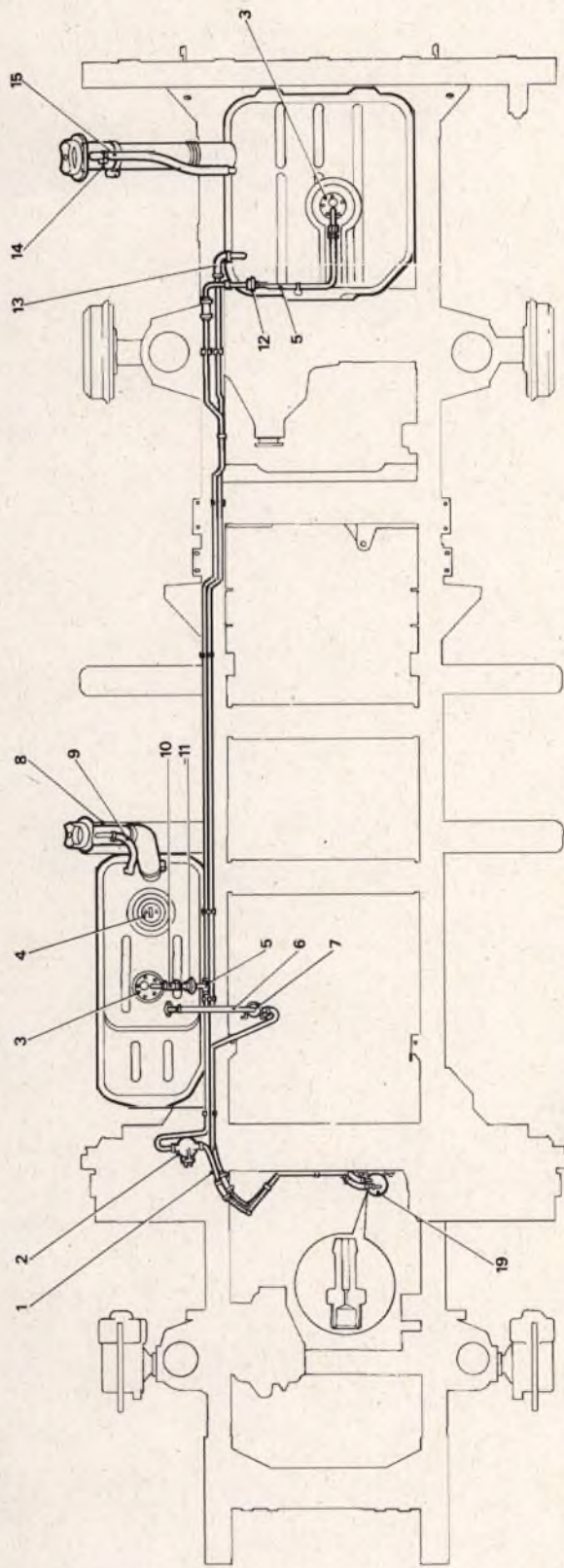
Fig 11 Exploded view of fuel injector



- | | |
|----------------------------------|--|
| 1 Fuel supply pipe | 8 Fuel pump |
| 2 Fuel filter | 9 Fuel gauge level unit |
| 3 Fuel supply pipe to filter | 10 Drain plug |
| 4 Non return valve | 11 Vapour separator, outlet to carburetter |
| 5 Spill return pipe to fuel tank | 12 Vapour separator |
| 6 Breather hose | 13 Restrictor |
| 7 Fuel filler | 14 Spill return pipe |

Fig 1

Land Rover 110 fuel pipe lay-out



LR8033L

- | | | | |
|----|--|----|--|
| 1 | Pipe, filter to vapour separator | 11 | Non - return valve |
| 2 | Fuel filter | 12 | Non - return valve |
| 3 | Fuel pump | 13 | Spill return pipe to rear tank from solenoid |
| 4 | Fuel gauge level unit - side tank | 14 | Fuel filler - rear tank |
| 5 | Fuel supply pipe - rear tank to filter | 15 | Breather pipe - rear tank |
| 6 | Spill return pipe to side tank | 16 | Fuel gauge level unit - rear tank |
| 7 | Spill return solenoid | 17 | Drain plugs |
| 8 | Fuel filler - side tank | 18 | Vapour separator outlet to carburetter |
| 9 | Breather pipe - side tank | 19 | Vapour separator |
| 10 | Connector pipe | | |

Land Rover 127 fuel pipe lay-out

Fig 2

Fuel pump

8 The fuel pump (Fig 3) is an electrically operated submerged unit mounted in the top of the tank, a filter bag (4) covers the pump inlet and a gasket (2) is provided between the fixing plate (6) and tank. Electrical connections (7) and the fuel delivery pipe extend through the tank fixing plate on top of the unit.

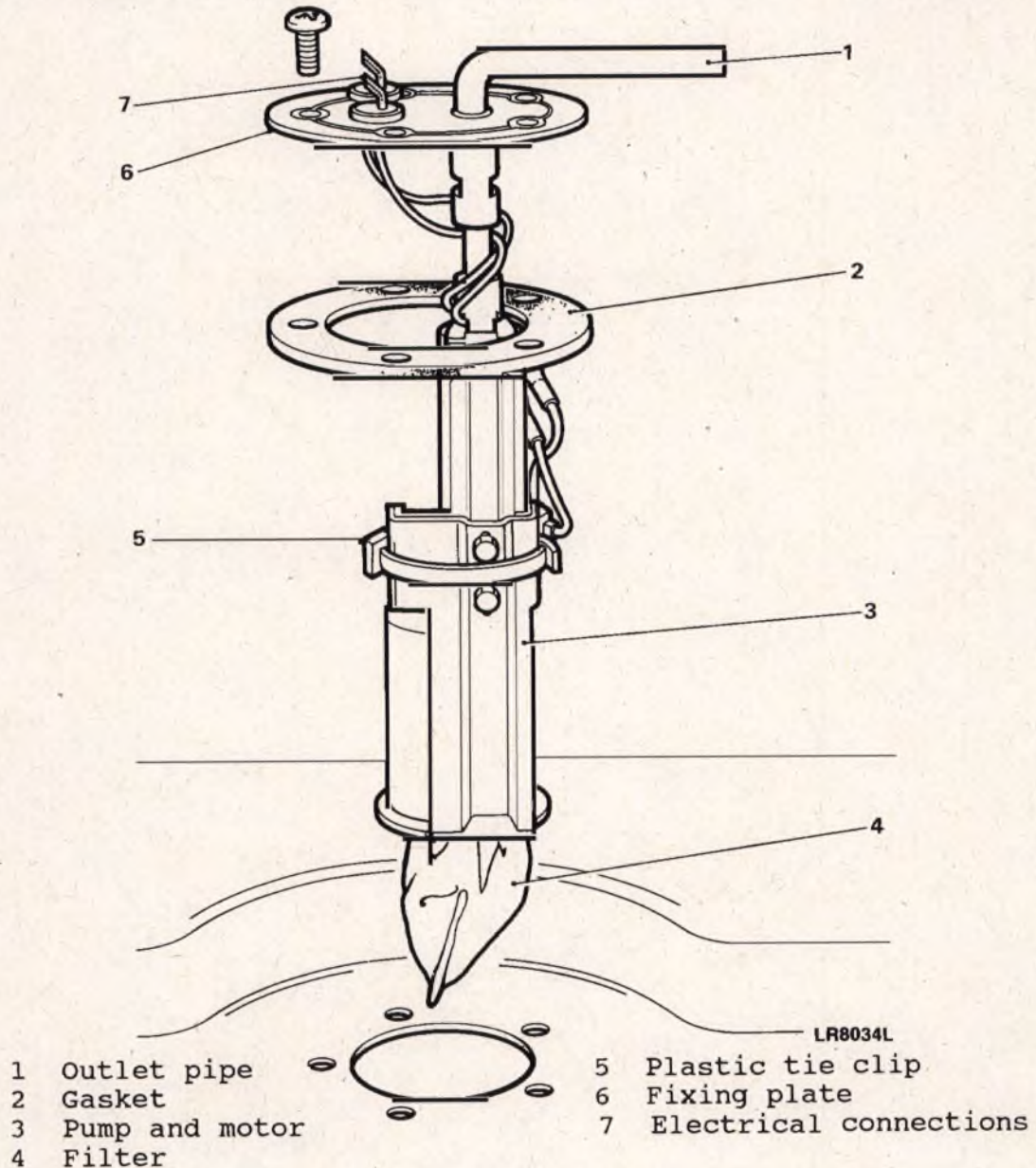


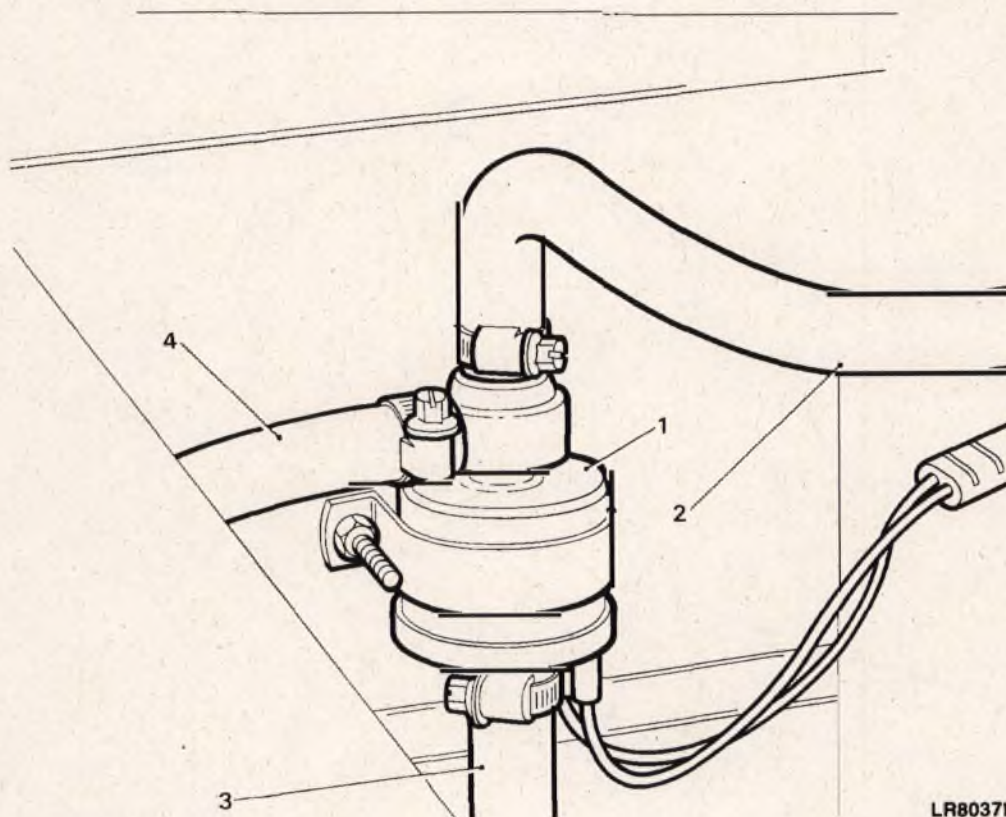
Fig 3 Fuel pump

Non-return valve

9 A non-return valve (Fig 4) is enclosed inside the hose connection of the supply pipe from both the rear and side tanks to prevent the possibility of a back flow of fuel along the supply lines to the fuel tanks.

Spill return solenoid valve

11 The spill return solenoid valve (Fig 6) is part of the spill return system incorporated on twin tank 127 vehicles only. The valve, which is energised by the tank selection switch, closes the port to the tank not in use and simultaneously opens the port to the selected tank.



- 1 Solenoid valve
- 2 Spill return to side tank
- 3 Spill return to rear tank
- 4 To carburetters via filter and vapour separator.

Fig 6 Spill return solenoid valve

Vapour separator and restrictor

12 The vapour separator (Fig 7) forms part of the spill return system and prevents fuel vapour causing air locks in the supply to the carburetter. Vapour and excess fuel flows back into the fuel tank through a restrictor fitted to the spill return port on the vapour separator.

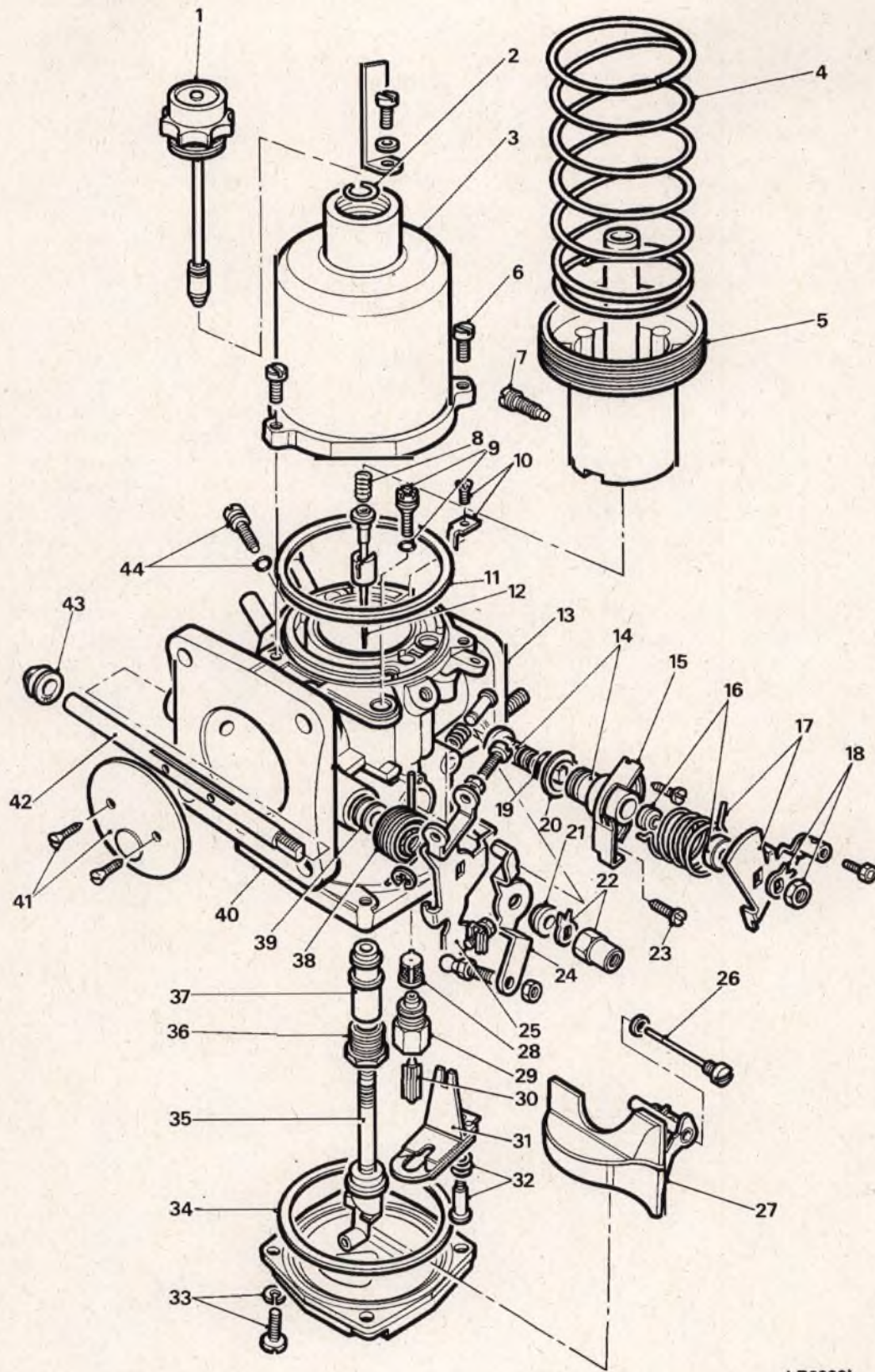
13 The restrictor is designed to assist in maintaining a constant fuel level in the vapour separator bowl and to prevent fuel flowing back to the tank at the same rate as the delivery.

Operation

15 The outlet pipe from the filter leads to the left hand carburetter float chamber, with a branch pipe supplying the right hand carburetter. Both carburetters are fitted with a mixture enriching device for engine starting from cold. When operated, this device draws supplementary fuel from the float chamber and feeds it directly into the carburetter throttle body. Under normal running conditions demand for fuel is controlled via a variable needle jet operated by an air piston positioned in the suction chamber on top the carburetter body.

Air cleaner

16 The air cleaner incorporating a replaceable element is mounted at the rear of the engine and is connected by hoses and ducting to the carburetters. In addition to supplying combustion air, clean air is also tapped off the ducting for the crankedcase ventilation system.



LR8039L

Fig 8 Carburetter

Jan 91 (Amdt 2)

Chap 11-2
Page 13

Chapter 11-2

PETROL FUEL AND EXHAUST SYSTEM

TECHNICAL DESCRIPTION

CONTENTS

Para

- 1 Introduction
- 2 General
- 3 Operation
- 5 Fuel tanks
- 6 Fuel filler
- 8 Fuel pump
- 9 Non-return valve
- 10 Fuel filter
- 11 Spill return solenoid valve
- 12 Vapour separator and restrictor
Carburetter
- 14 Description
- 15 Operation
- 16 Air cleaner
- 17 Exhaust system

Fig

Page

- 1 Land Rover 110 fuel pipe lay-out 3/4
- 2 Land Rover 127 fuel pipe lay-out 5/6
- 3 Fuel pump 7
- 4 Non-return valve 8
- 5 Fuel filter 8
- 6 Spill return solenoid valve 9
- 7 Vapour separator 10
- 8 Carburetter 13

INTRODUCTION

1 This chapter covers the petrol fuel and exhaust system fitted to Land Rover 110 and 127 vehicles.

GENERAL

2 The fuel systems for Land Rover 110 and 127, having 3.5 litre V8 engines, are identical except for the addition of a side mounted tank on 127 vehicles only. The system consists of fuel tanks, fuel pump, fuel supply and spill return lines, vapour separator, fuel filter, carburetters and an air cleaner.

OPERATION

3 Fuel drawn by the electrically operated in-tank pump, is delivered to a paper element type filter. From the filter, the fuel enters the carburetter float chamber via a vapour separator. Vapour and excess fuel returns to the fuel tank through a restrictor fitted to the return port on the vapour separator.

Chapter 11-3

PULSAIR SYSTEM (DERATED ENGINE ONLY)

TECHNICAL DESCRIPTION

CONTENTS

Frame	Para		Page
	1	Introduction	
	2	General	
	3	Operation	
	8	Inlet manifold	
	9	Pulsair manifold	
	10	Check valves	
	11	Exhaust system	
	Fig		
	1	Pulsair system	2
	2	Pulsair layout	3

INTRODUCTION

1 This chapter covers the pulsair system fitted to the derated 3.5 litre V8 engine installed in Land Rover 110 vehicles.

GENERAL

2 Due to restrictors fitted into the inlet manifold of the derated V8 engine a pulsair system (Fig 1) has been installed to control exhaust emissions. The additional equipment makes no changes in the maintenance and repair procedures already covered in the fuel system except for the pulsair rails and check valves which are covered in this chapter.

OPERATION

3 Pulsair is self-induced air injection into the exhaust ports via a configuration of pipes from the carburetter elbows, employing two one way pulse air valves.

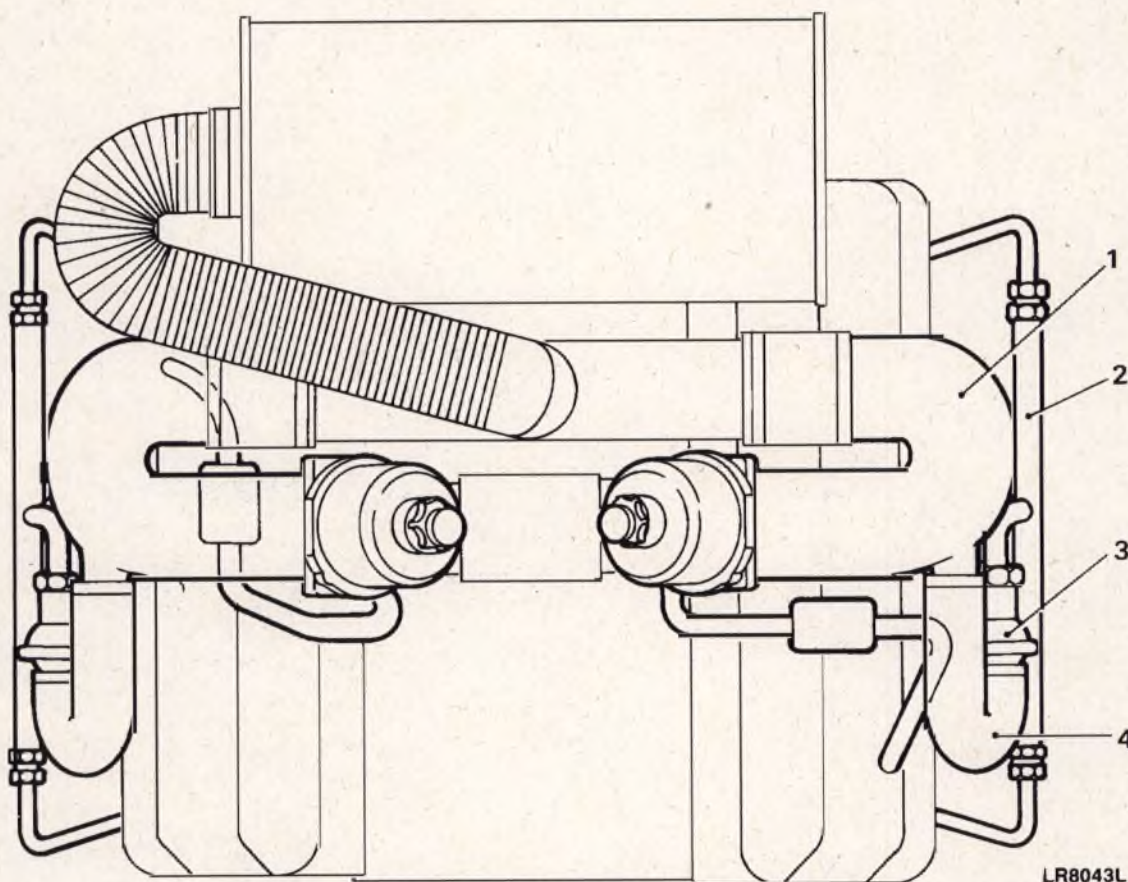
4 Air is drawn from the carburetter elbows (2) via a pressure check valve (3) then to the injectors (5) in the individual exhaust ports, adjacent to the exhaust valves. The air mixes with the exhaust gases leaving each cylinder and promotes secondary combustion within the exhaust ports, manifolds and exhaust system.

5 The check valve (3) is a simple one-way flap valve, to prevent gases passing back through the elbows.

6 Cranckcase gases are utilised by the constant depression area of the carburetter, gases are recycled from the cranckcase via the rocker cover, flame trap and carburetter to the induction system.

Check valves

10 The check valves are simple one-way flap valves and are connected to the pulsair manifolds by a threaded union. A flexible hose connects the other end of the valve to the carburetter elbows.



- | | |
|--------------------|--------------------|
| 1 Intake elbows | 3 Pulsair manifold |
| 2 Pulsair manifold | 4 Hoses |

Fig 2 Pulsair layout

EXHAUST SYSTEM

11 For technical description details of the exhaust system refer to Cat 302 Chap 11-2.

Chapter 12

COOLING SYSTEMS

TECHNICAL DESCRIPTION

INTRODUCTION

1 This Chapter gives the technical description for the cooling systems fitted to Land Rover 2.5 litre diesel 90 and 110 vehicles, and Land Rover 3.5 litre petrol 110 and 127 vehicles.

2 The Chapter has been Sub-chaptered as follows to accommodate the cooling system fitted to Land Rover 2.5 litre diesel 90 and 110 vehicles, and the cooling system fitted to Land Rover 3.5 litre petrol 110 and 127 vehicles.

Chapter 12-1 2.5 L DIESEL COOLING SYSTEM 90/110

Chapter 12-2 3.5 L PETROL COOLING SYSTEM 110/127

Chapter 12-3 WINTERISED COOLING SYSTEM

General

3 The information given is applicable to both left and right hand drive vehicles.

Chapter 12-1

2.5L DIESEL COOLING SYSTEM 90/110

CONTENTS

Frame	Para	Page
	1 Introduction (WARNING) Description	
	2 General	
	3 Radiator	
	4 Thermostat	
	5 Water pump	
	7 Fan and viscous coupling	
	8 Operation	
Fig		Page
	1 Water pump, fan and viscous coupling	2

INTRODUCTION

1 This chapter covers the technical description for the cooling system as fitted to Land Rover 90 and 110 vehicles.

WARNING ...

DO NOT REMOVE THE RADIATOR OR EXPANSION TANK FILLER CAPS WHEN THE ENGINE IS HOT BECAUSE THE COOLING SYSTEM IS PRESSURIZED AND PERSONAL SCALDING COULD RESULT.

DESCRIPTION

General

2 The cooling system is a thermo-syphon, pump assisted, thermostatically controlled arrangement designed to ensure that the engine is maintained at the approved running temperature at a wide range of weather conditions.

Radiator

3 The radiator is of the cross flow type having tanks at either side inter-connected by specially shaped tubes having gills inter-spaced about them. The tank on the right hand side of the radiator, when viewed from the driving position, has a hose connection at the bottom for coolant flow to the engine, a small hose connection at the top, for flow to the expansion tank and a filler plug on the top face. The tank on the left hand side has a hose connection at the top to receive the hot coolant from the engine.

Thermostat

4 Fitted to the front of the cylinder head, the thermostat assembly consists of an external housing, a temperature sensitive bellows and a top cover. Connections are provided on the thermostat housing to allow the hot coolant to be circulated to the heater.

Viscous coupling and fan

Description and operation

Description

7 The viscous coupling assembly, comprises a disc which is the driving member, secured with a lock nut to a left hand threaded boss formed on the end of an adapter fitted to the water pump shaft. A casing, which is the driven member, is finned to dissipate heat and is divided into two chambers by a separator plate; the rear chamber houses the disc and the front one forms a reservoir. A scoop, mounted on the separator plate, transfers fluid from the rear chamber to the front. A thermostatically-actuated valve situated near the centre of the plate allows the oil to return to the rear chamber; the thermostatic control element is mounted in front of the casing where it is exposed to the air flow through the radiator. The casing is filled with a viscous silicone fluid and also forms the mounting for the multi-bladed fan which has irregular spaced blades to minimise noise.

Operation

8 When the engine is started, drive from the pulley rotates the disc and residual fluid in the rear chamber passes through the scoop into the front chamber, so that no drive is transmitted to the casing. When the engine coolant rises above a pre-determined temperature the hot airflow from the radiator, passing over the thermostatic control element, actuates the valve and allows the fluid to re-enter the rear chamber. The fluid is distributed over the disc by centrifugal force, this action permits the drive to pass from the disc to the casing and thereby rotate the fan. The coupling is designed to allow the fan to slip when it reaches a pre-determined speed and maintain that speed irrespective of increases in engine speed. To prevent overheating in traffic conditions or high ambient temperatures, a bi-metallic thermocouple overrides the viscous action at underbonnet temperatures in excess of 70°C and increases the fan speed.

SYSTEM OPERATION

9 Under normal operating conditions, coolant is drawn from the bottom of the right hand tank of the radiator, viewed from the drivers position, then pumped through the cylinder block and cylinder head to return to the radiator left hand tank, from there it flows through the cooling cross tubes to the right hand tank, completing the cycle.

9 The thermostat maintains the coolant at the approved working temperature by controlling the flow of coolant to the left hand tank. When the engine is cold, coolant is prevented from returning to the radiator by the thermostat, coolant is then by-passed from the cylinder head to the pump and back to the cylinder block, thus the approved working temperature is quickly reached. As the coolant temperature rises the thermostat at a pre-determined setting will begin to open, allowing some of the coolant to flow to the radiator for cooling. Any rise in temperature above the normal operating range will cause the thermostat to open further allowing a greater volume of coolant to flow to the radiator, thereby lowering the temperature.

Chapter 12-2

3.5 L PETROL COOLING SYSTEM 110/127

CONTENTS

Frame Para

- 1 Introduction (WARNING)
Description
- 2 General
- 3 Radiator
- 4 Thermostat
- 5 Water pump
- 7 Fan and viscous coupling
- 8 Oil cooler
- 9 Operation

Fig

Page

- 1 Water pump, fan and viscous coupling

2

INTRODUCTION

1 This chapter details the technical description for the water and oil cooling systems fitted to the Land Rover 3.5 Litre Petrol 110 and 127 vehicles.

WARNING ...

DO NOT REMOVE THE RADIATOR OR EXPANSION TANK FILLER CAPS WHEN THE ENGINE IS HOT BECAUSE THE COOLING SYSTEM IS PRESSURISED AND PERSONAL SCALDING COULD RESULT

DESCRIPTION

General

2 The conventional water cooling system is an efficient pump assisted arrangement with thermostatic control. On the 12/24 V vehicles a supplementary oil cooling circuit is provided. The cooling system is designed to maintain the correct running temperature over a wide range of weather conditions.

Radiator

3 The radiator is of the cross flow type having tanks at either side interconnected by tubes providing the heat exchanging surface. When viewed from the driving position, the right hand tank contains bottom hose connection to the engine, smaller hose connections at the top for expansion tank and penthouse bleed, the filler plug is also located on the top face. The left hand tank houses the top hose connection receiving hot coolant from the engine.

Thermostat

4 Fitted to the front of the cylinder head, the thermostat assembly consists of an external housing, temperature sensitive bellows and a top cover. Connections are provided on the thermostat housing to allow the hot coolant to be circulated to the heater.

Water Pump

5 A centrifugal impeller type water pump (Fig 1(3)) is mounted on the timing chain cover (1) and is belt driven from the crankshaft pulley.

6 The pump body is a single casting incorporating spindle and bearing assembly. A cassette type seal unit excludes coolant from the bearing and prevents leakage. Pressed on the inner end of the spindle is an impeller. A drive hub is pressed on the outer end of the spindle to which is secured the drive pulley (5), fan (6) and viscous coupling (7).

Fan and Viscous Coupling

7 A left hand thread formed on the end of the water pump shaft carries the fan and viscous coupling assembly (6,7) and is secured to the hub by a lock nut. The viscous coupling (7) allows the fan to slip upon reaching a pre-determined speed and maintain that speed irrespective of increases in engine speed. The multi-bladed fan has irregular spaced blades to minimise noise.

Oil cooler

8 On 12/24V vehicles only, an auxiliary oil cooling facility is provided to prevent engine overheating during extended periods of running the engine when stationary.

OPERATION

9 Under normal operating conditions, coolant is drawn from the bottom of the right hand tank of the radiator, viewed from the drivers position, then pumped through the cylinder block and cylinder head to return to the radiator left hand tank; from there it flows through the cooling cross tubes to the right hand tank, completing the cycle.

10 The thermostat maintains the coolant at the approved working temperature by controlling the flow of coolant to the left hand tank. When the engine is cold, coolant is prevented from returning to the radiator by the thermostat, coolant is then by-passed from the cylinder head to the pump and back to the cylinder block.

11 As the coolant temperature rises the thermostat at a pre-determined setting will begin to open, allowing some of the coolant to flow to the radiator for cooling. Any rise in temperature above the normal operating range will cause the thermostat to open further allowing a greater volume of coolant to flow to the radiator, thereby lowering the temperature.

Chapter 12-3

WINTERISED COOLING SYSTEM

CONTENTS

Frame	Para		Page
	1	Introduction (WARNING)	
	2	General	
		Water heater unit	
	4	Description	
	6	Operation	
		Pre-heater water circuit	
	10	Operation	
	Fig		
	1	Section through Webasto DBW 46 water heater	2
	2	Water circuit	5/6

INTRODUCTION

1 This chapter details the technical description for the cooling system fitted to Land Rover 2.5 litre diesel winterised 90 and 110 vehicles.

WARNING ...

DO NOT REMOVE THE RADIATOR OR EXPANSION TANK FILLER CAPS WHEN THE ENGINE IS HOT. THE COOLING SYSTEM IS PRESSURISED AND THE RAPID RELEASE OF HOT COOLANT COULD RESULT IN PERSONAL INJURY.

GENERAL

2 For technical description details of the main cooling system refer to 'Cat 302 Chap 12-1.

3 Land Rover winterised 90 and 110 vehicles have been specifically designed to operate in extreme sub-zero climatic conditions. In order to meet the required specification a 'Wabasto' DBW 46 water heater has been incorporated as an aid to engine cold start procedure. An integral radiator/oil cooler providing oil temperature regulation is also fitted.

Water heater

Description

4 The water heater operates independently of the engine and is connected into the cooling system, fuel system and electrical installation of the vehicle.

Operation

6 When the heater is operated via the instrument panel switch, a positive charge is sent to the electronic control unit which in turn ignites the glow plug coil and activates the water circulation pump. An operation indicator light is illuminated in the instrument panel. After a delay of approximately 30 seconds the dosing pump is activated, forcing diesel fuel oil through the inlet pipe and on to the burner matting. Approximately five seconds later, the combustion air fan is activated, driving clean air into the burner. The burner matting acts as a wick supplying evaporated fuel over the cross-section of the burner tube. If combustion is not established, the flame detector initiates a second start cycle and ignition continues for a maximum period of four minutes, or until combustion. If a second combustion failure occurs the flame detector initiates a heater shut down.

7 Immediately after combustion is established the flame detector extinguishes the glow plug. A temperature sensor mounted in the heat exchanger records the water temperature which will continue to rise and is eventually maintained between 70° and 80°C by combustion air fan and dosing pump frequency changes, governed from the electronic control unit.

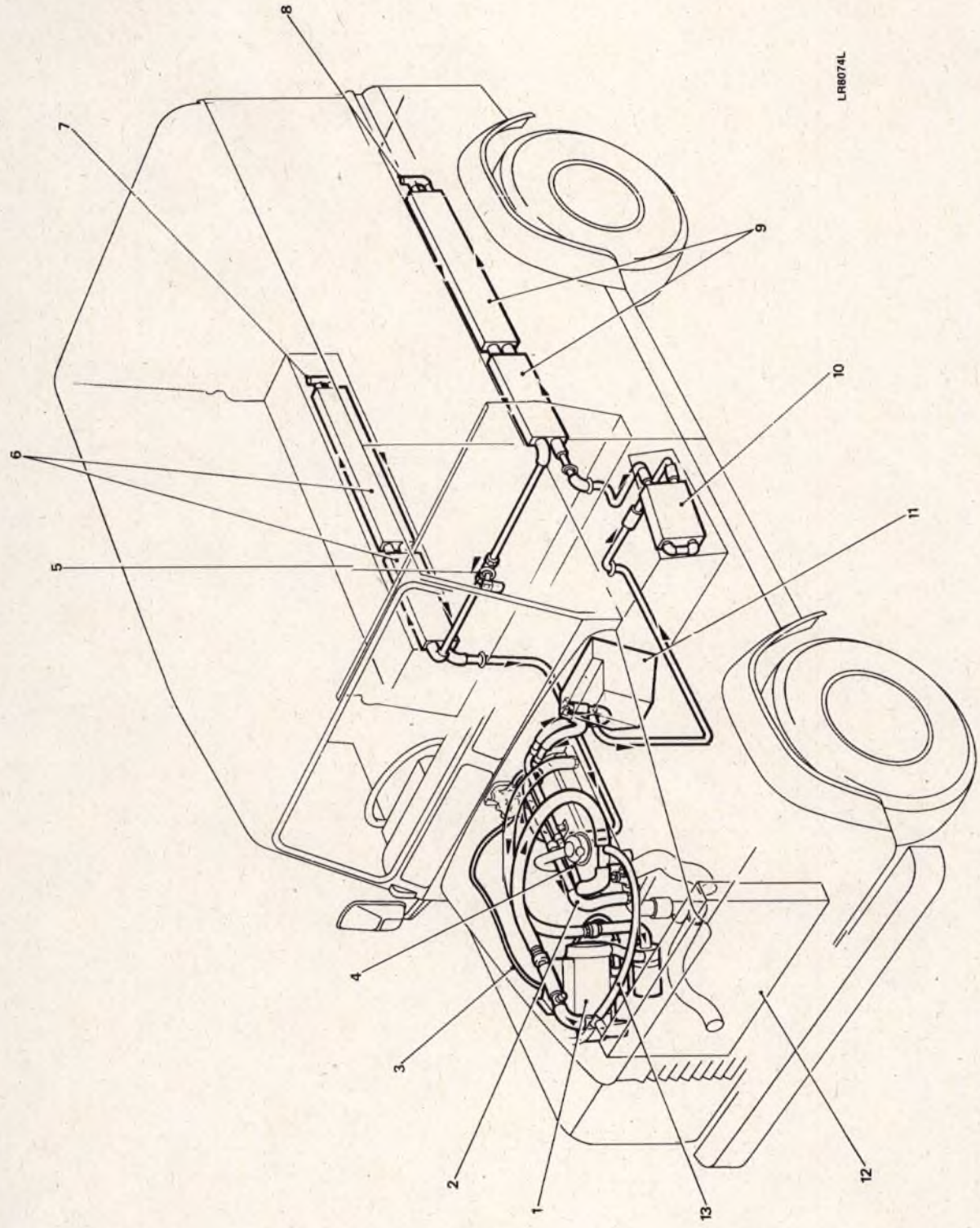
8 If the water temperature rises above 85°C, a purge cycle commences. In such an event, the dosing pump is de-energised, the glow plug is extinguished and the combustion air fan is activated to full load. This safety procedure ensures the combustion chamber is bled, and any gas is removed, thus allowing necessary cooling to commence. A purge cycle is also initiated when the heater is switched off. As a final safety precaution a manual reset overheat fuse incorporating a fusible plug which is blown at a permissible temperature is also fitted into the heat exchanger.

9 During normal operation exhaust gases are released from the burner through the exhaust pipe and silencer. An intake silencer is also secured to the combustion air intake pipe to reduce noise.

Pre-heater water circuit

Operation

10 Prior to engine ignition, water is drawn by the circulation pump from the engine and into the heat exchanger via a connection located at the rear of the cylinder head (Fig 2). Hot water is then forced out of the heat exchanger and back into the engine via a second connection located at the front of the cylinder head. An expansion hose is incorporated via a tee fitted into the same front cylinder head connection. Operation of the water heater and circulation pump automatically terminates when the engine is ignited.



Water circuit

[REDACTED]
[REDACTED]
[REDACTED]

[REDACTED]

[REDACTED]

[REDACTED]

[REDACTED]

[REDACTED]

[REDACTED]

[REDACTED]

[REDACTED]

[REDACTED]

[REDACTED]

[REDACTED]

[REDACTED]

[REDACTED]

[REDACTED]

[REDACTED]

[REDACTED]

[REDACTED]

[REDACTED]

[REDACTED]

[REDACTED]

[REDACTED]

[REDACTED]

[REDACTED]

[REDACTED]

[REDACTED]

[REDACTED]

[REDACTED]

[REDACTED]

[REDACTED]

[REDACTED]

[REDACTED]

[REDACTED]

[REDACTED]

[REDACTED]

[REDACTED]

[REDACTED]

[REDACTED]

[REDACTED]

[REDACTED]

[REDACTED]

[REDACTED]

[REDACTED]

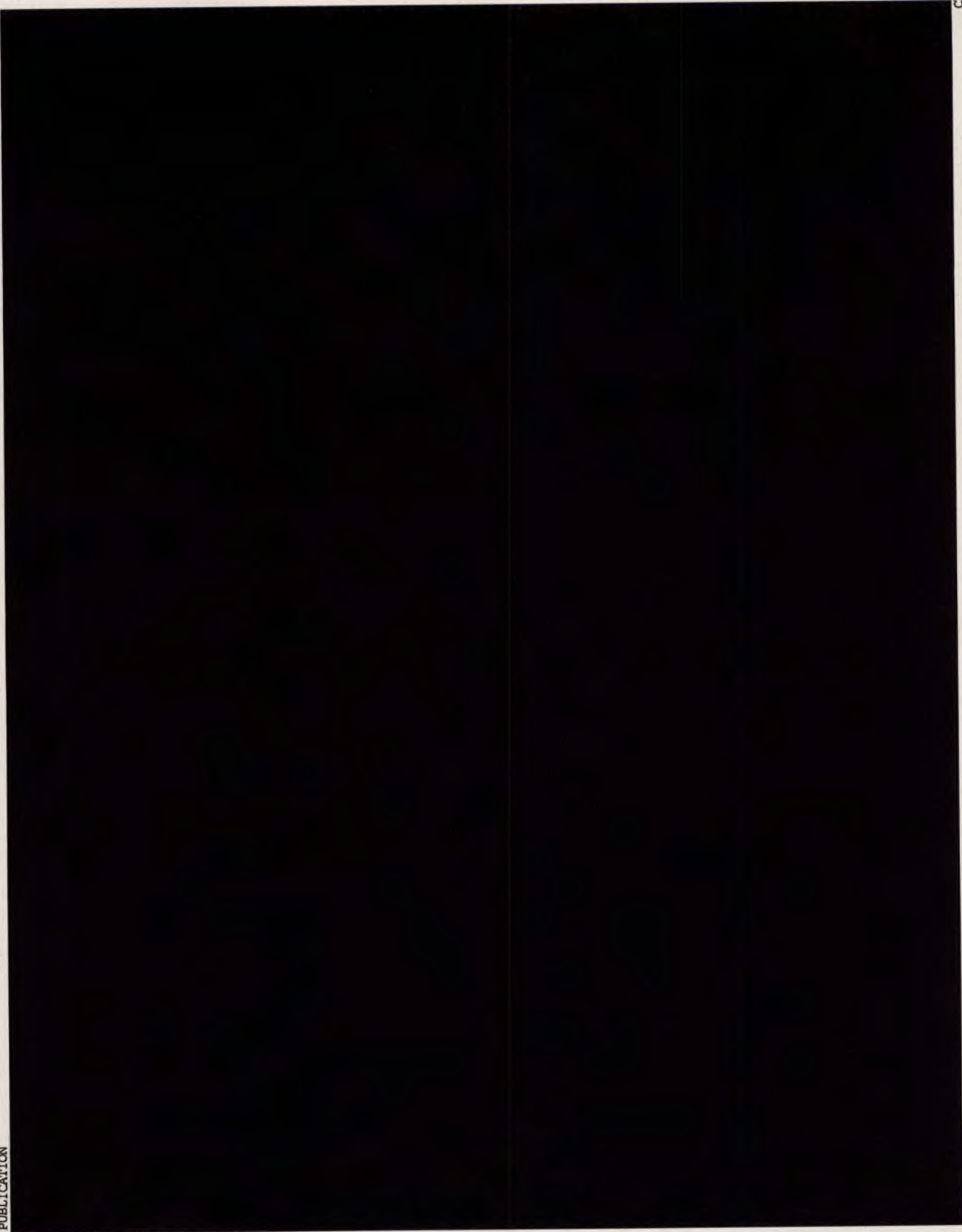
[REDACTED]

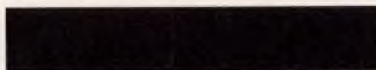
[REDACTED]

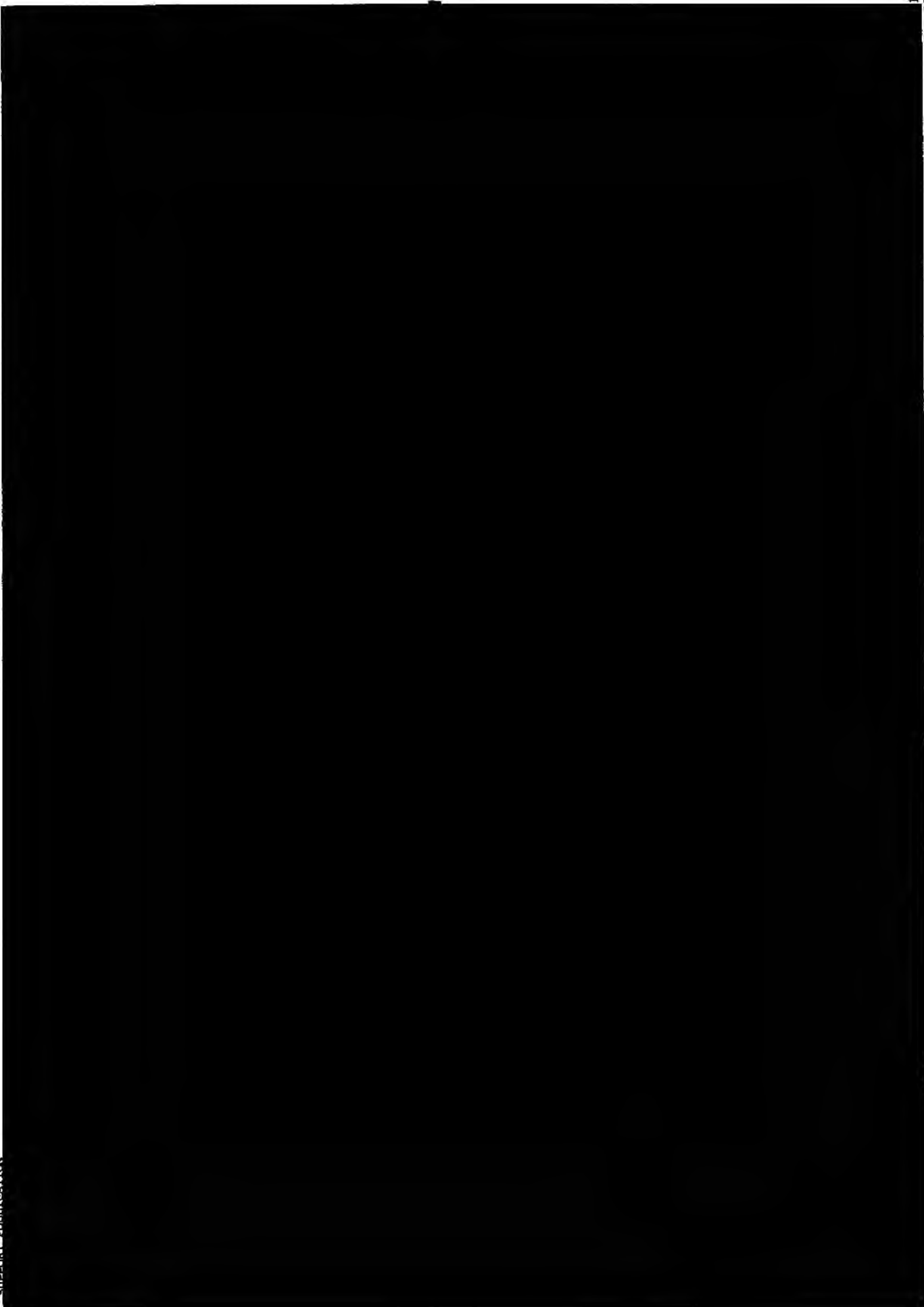
[REDACTED]

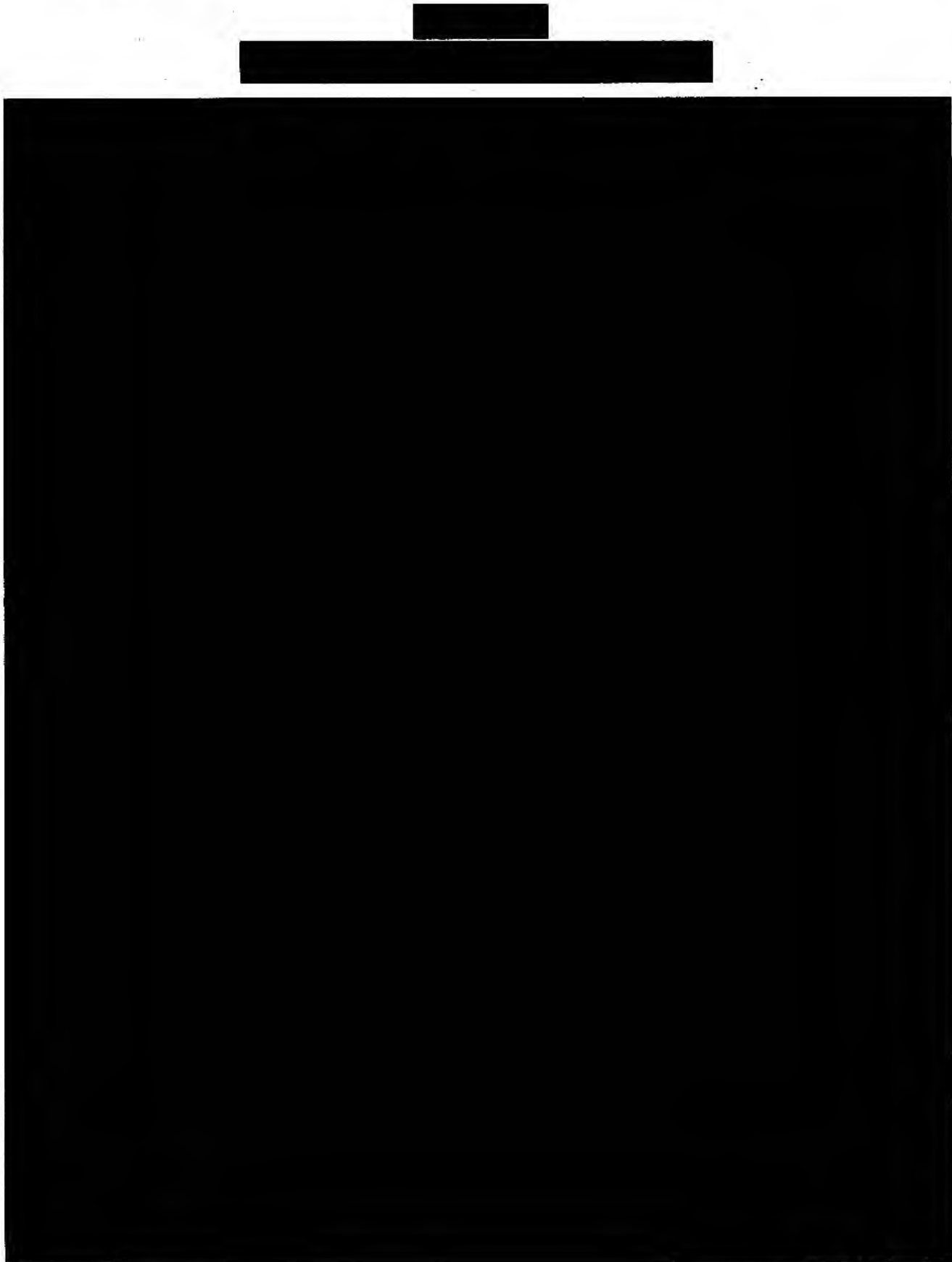
[REDACTED]

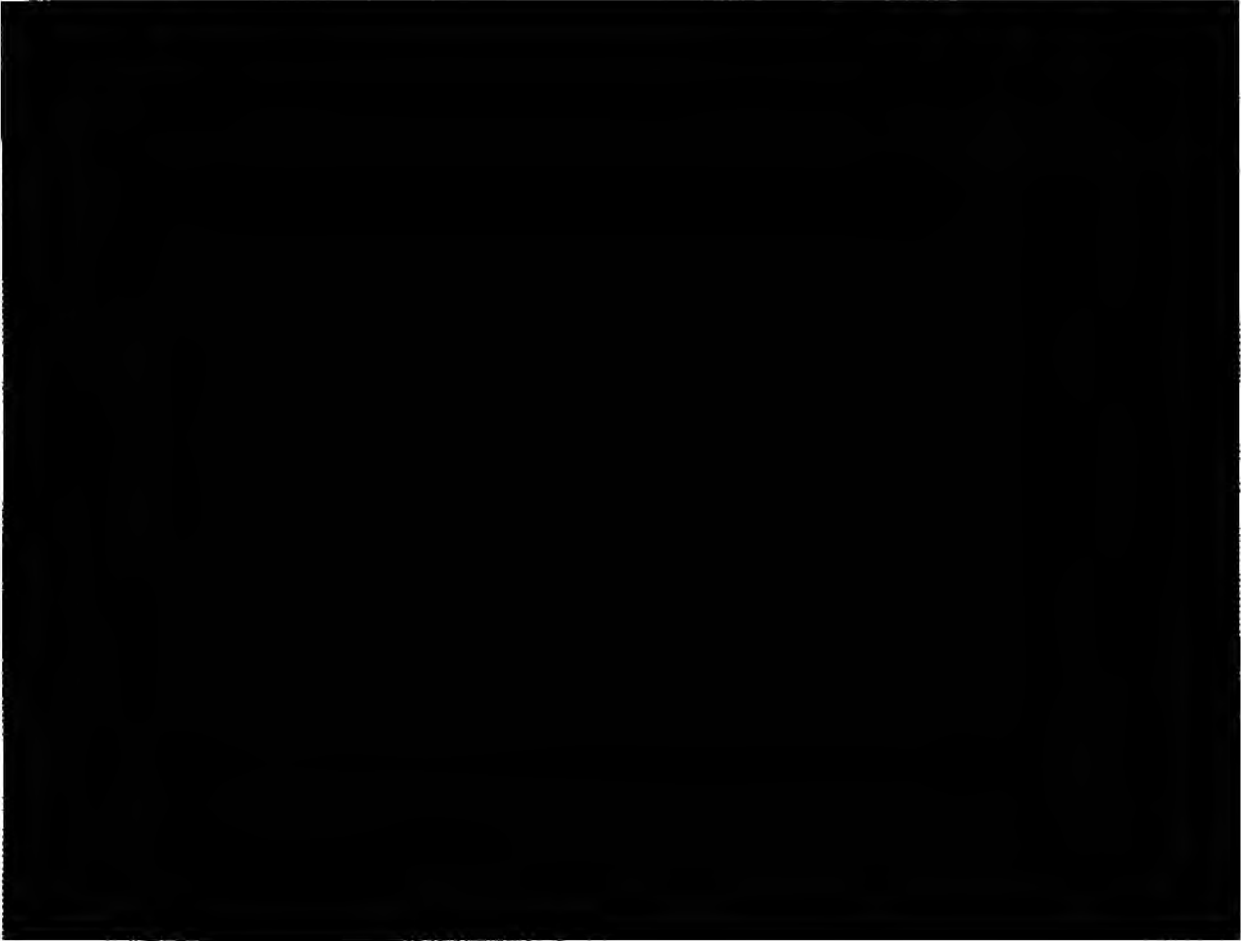




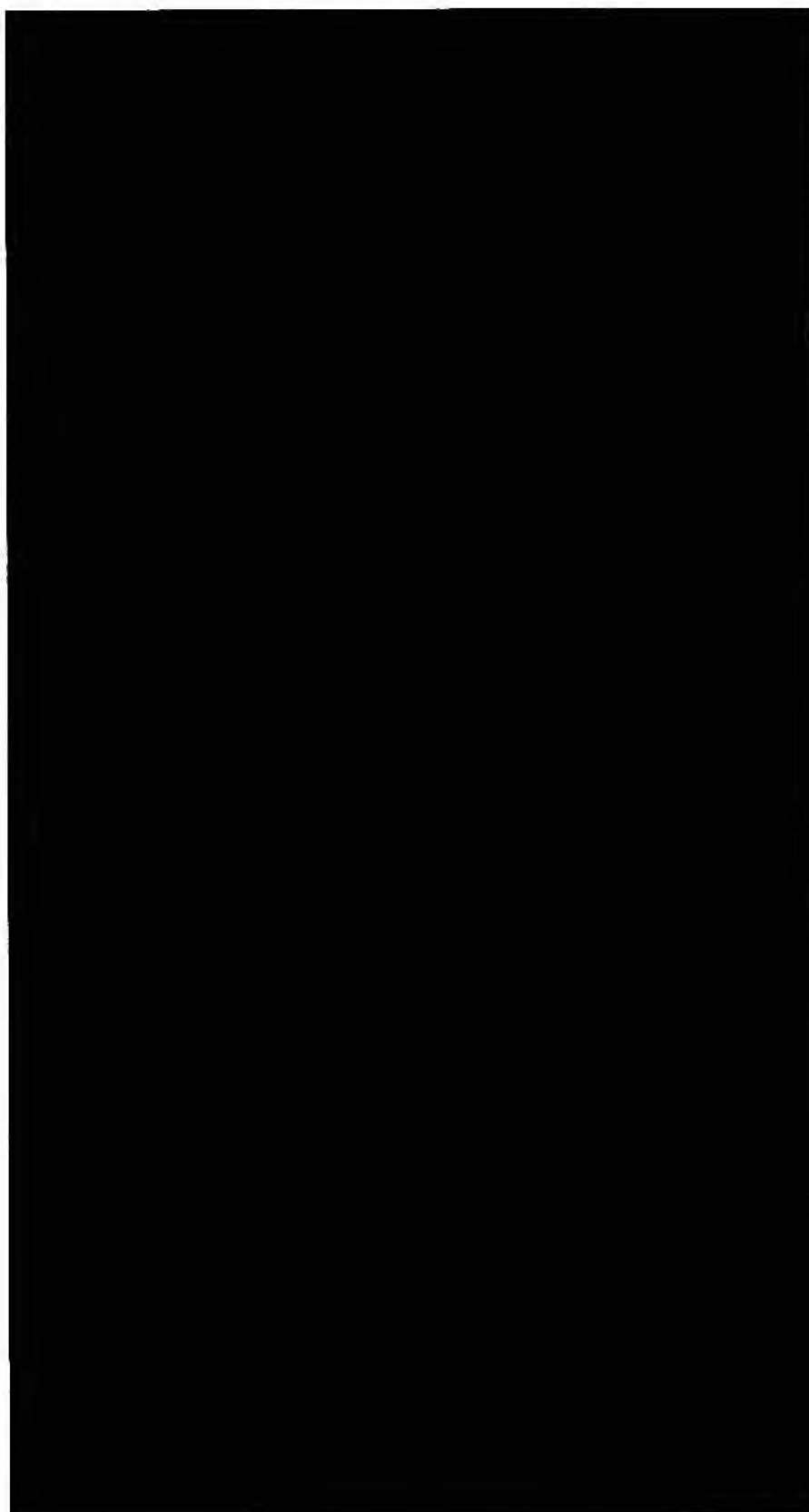


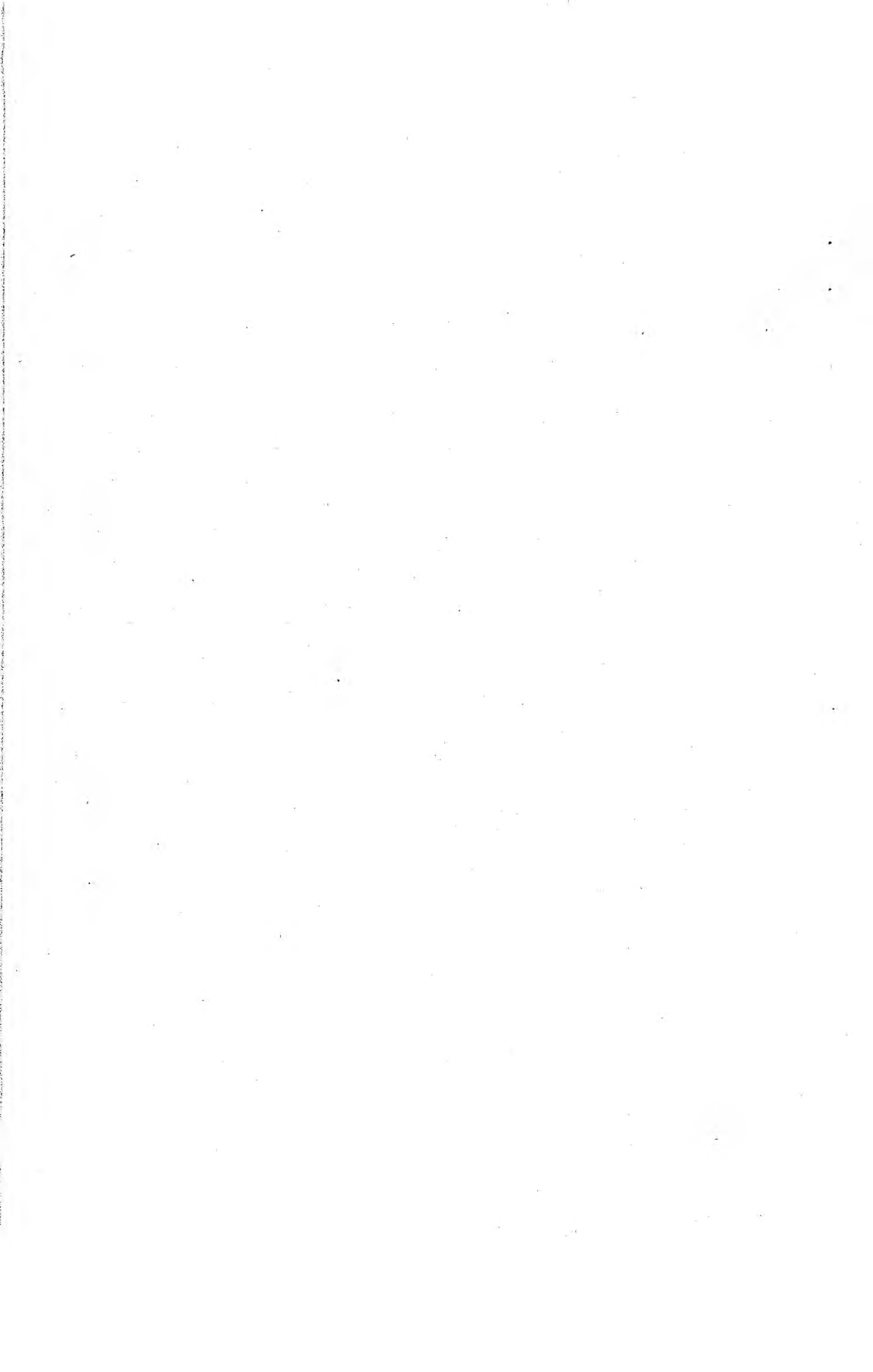


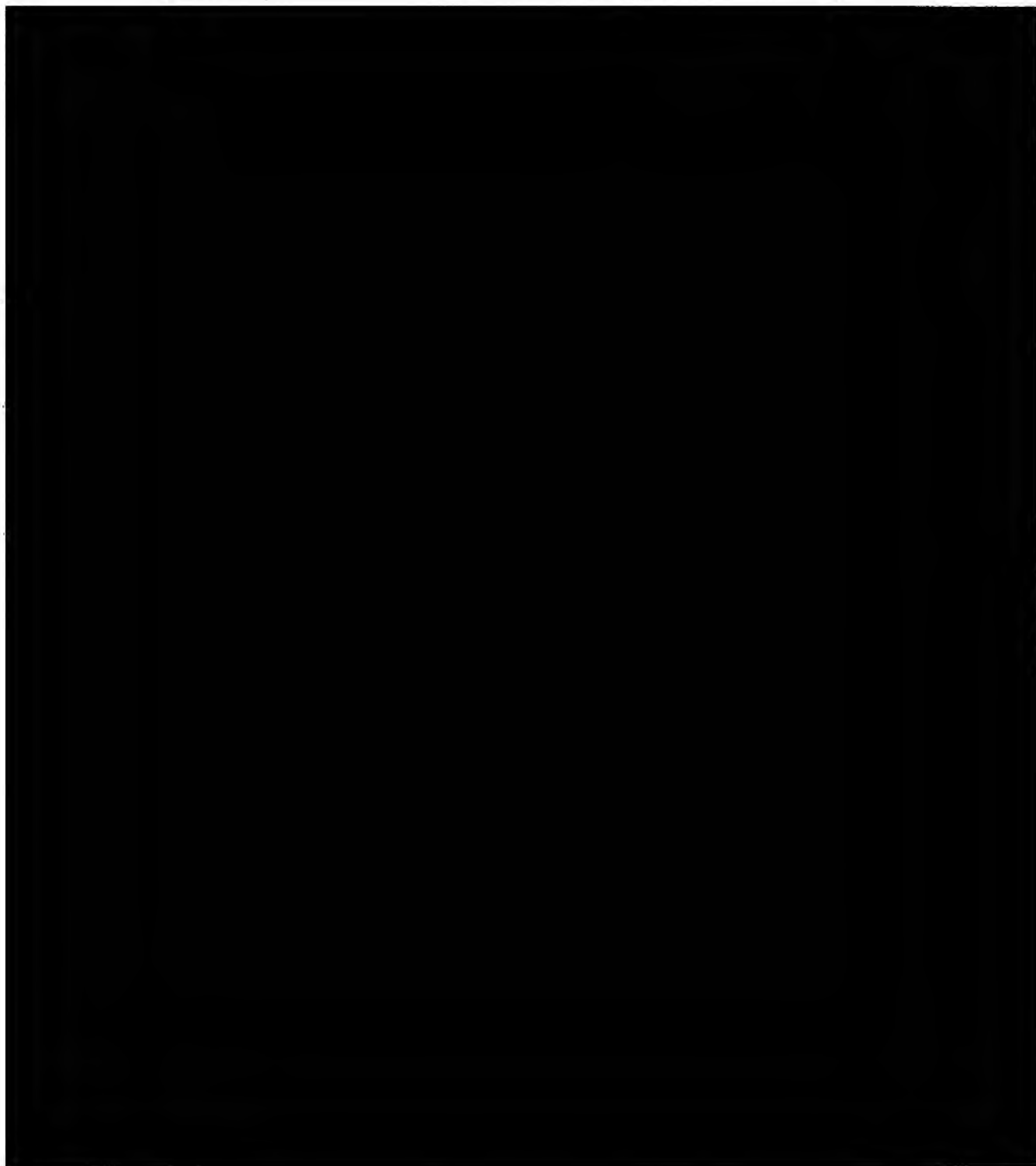


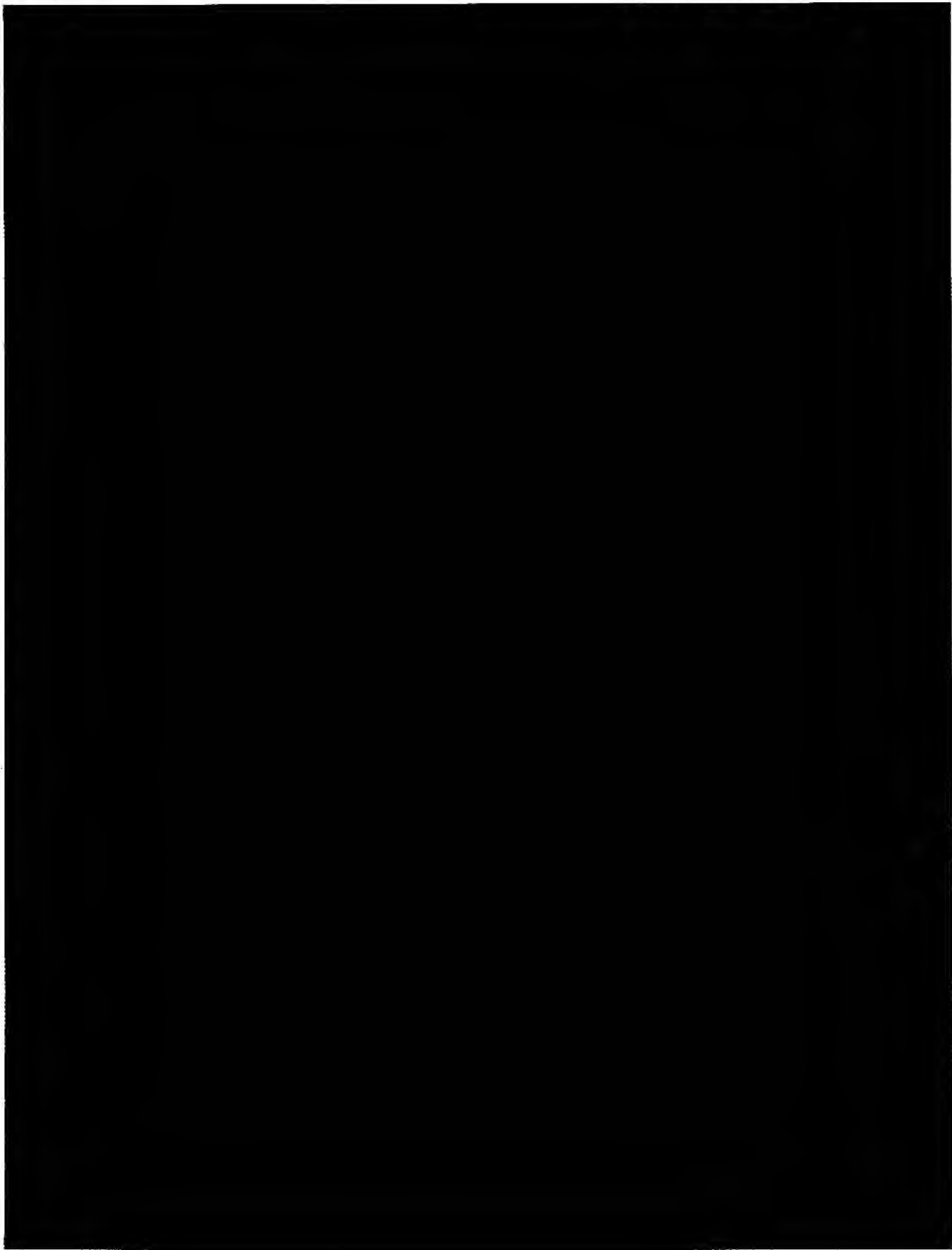


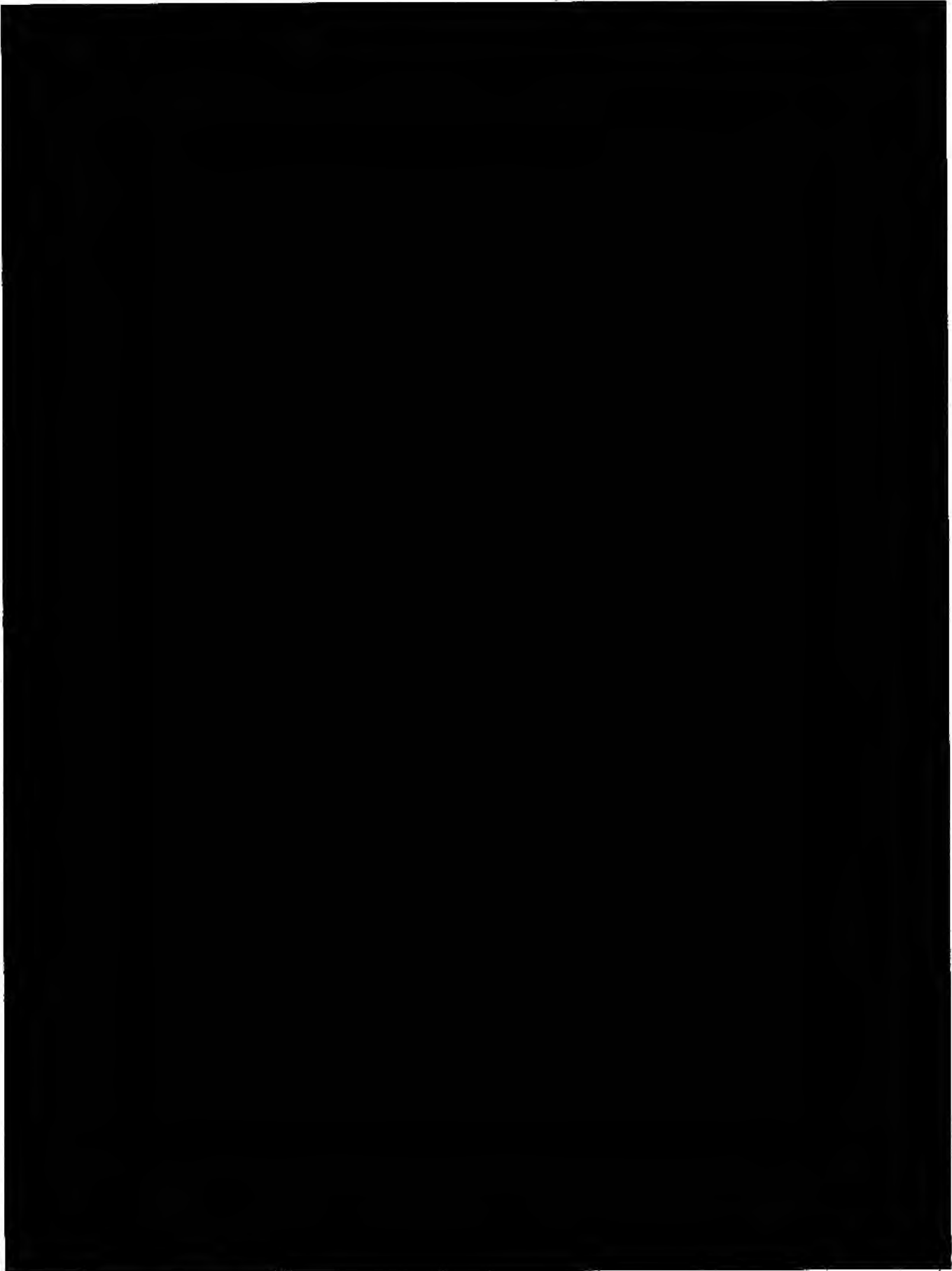








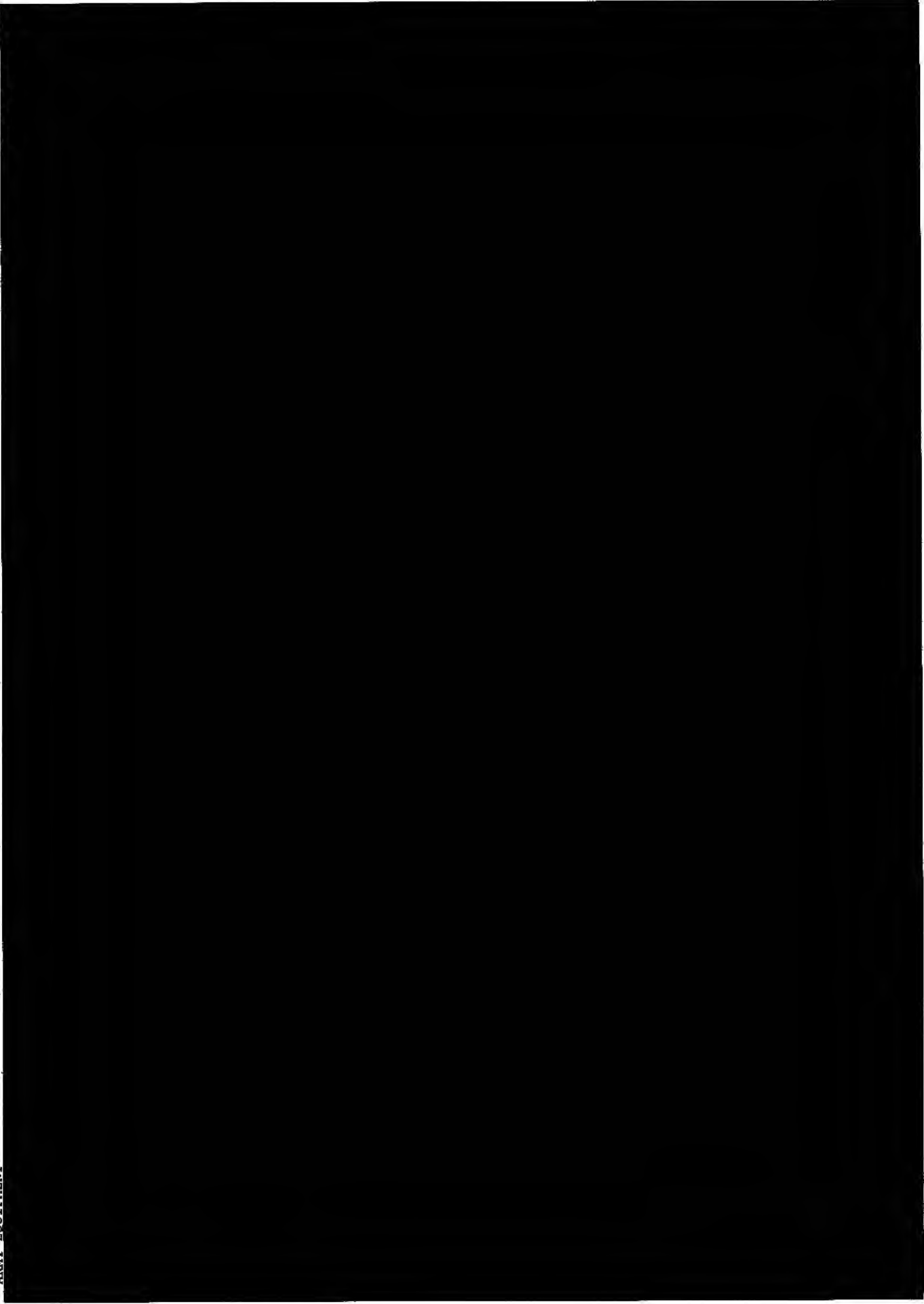


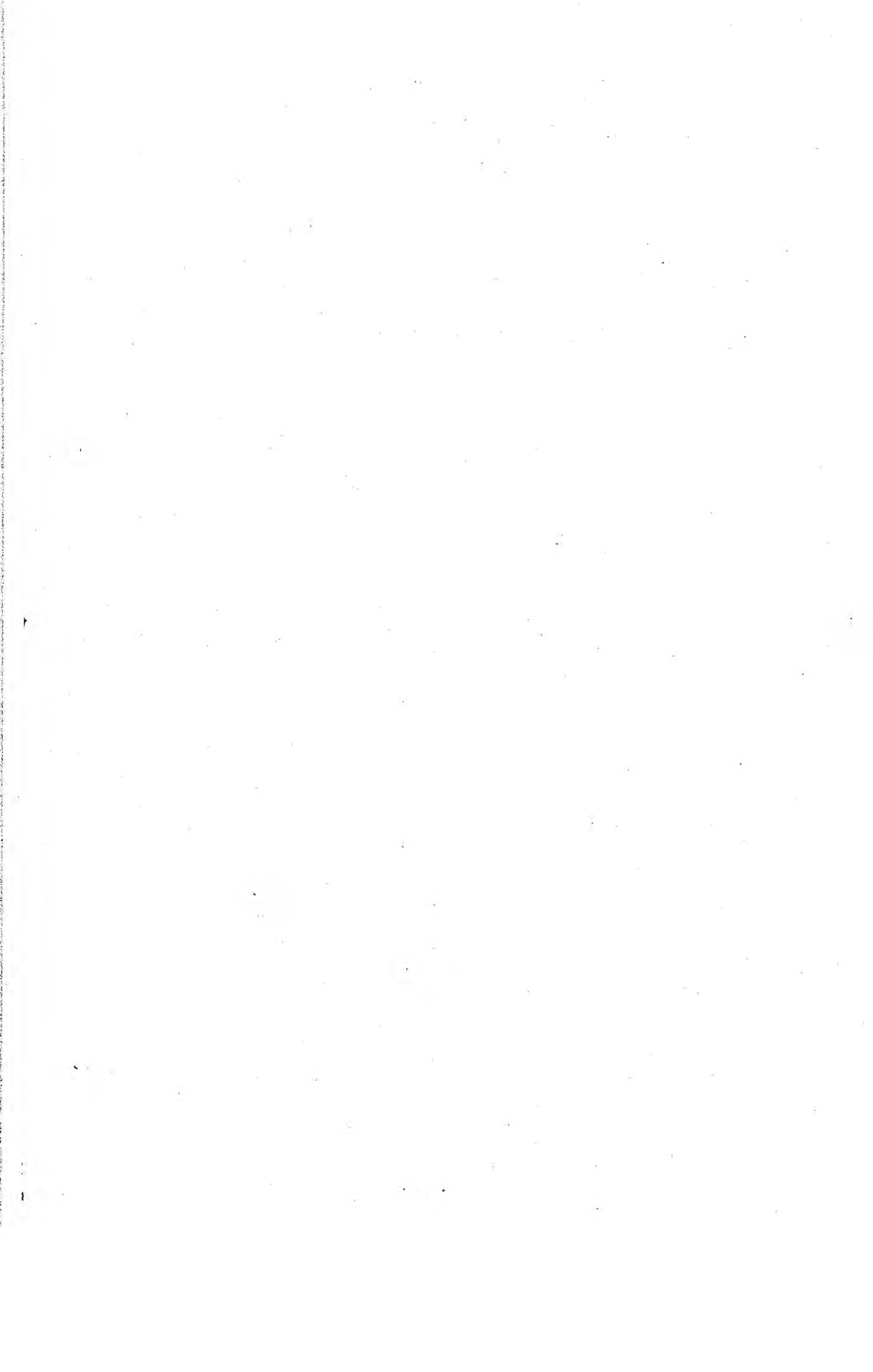


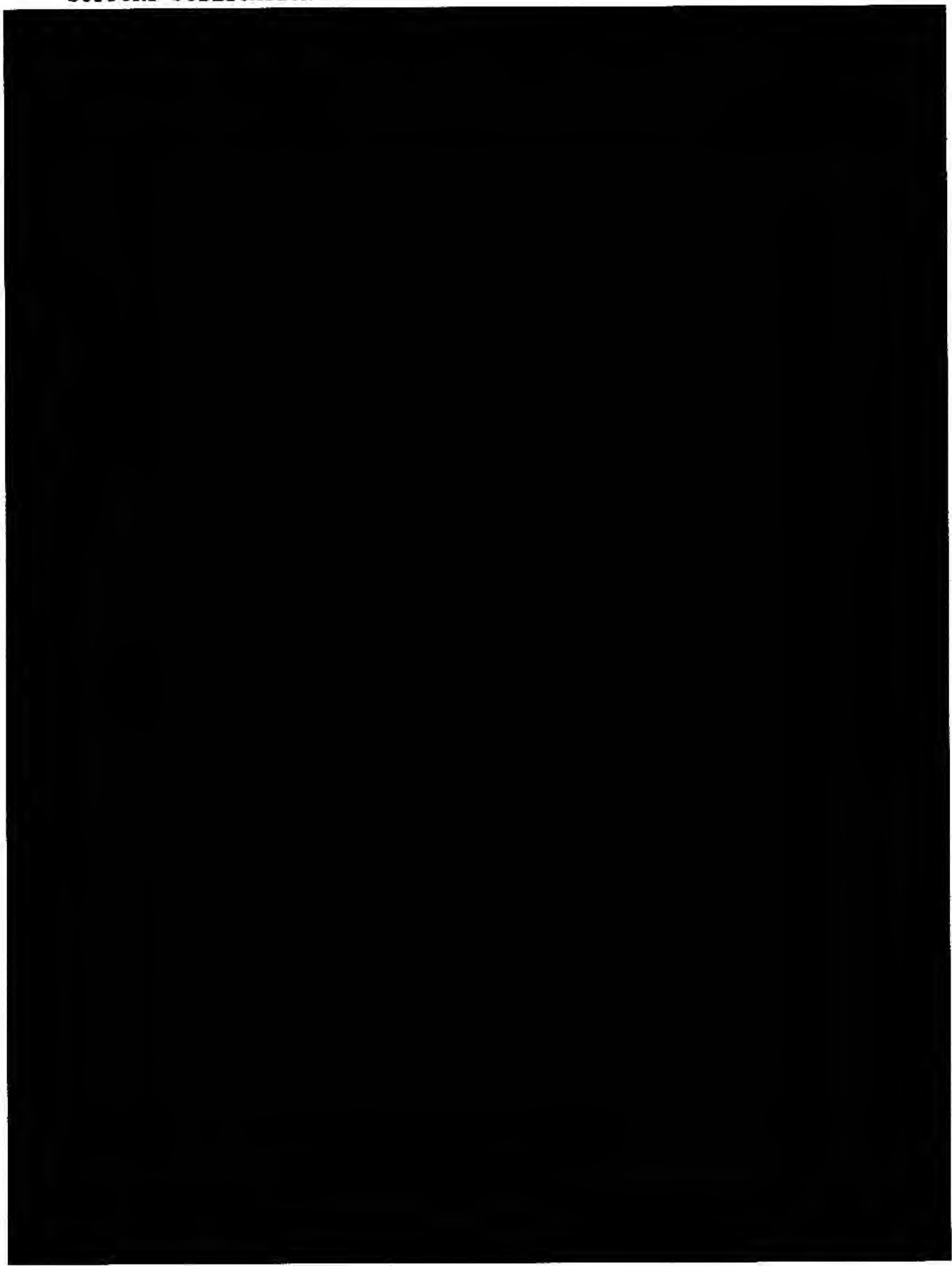


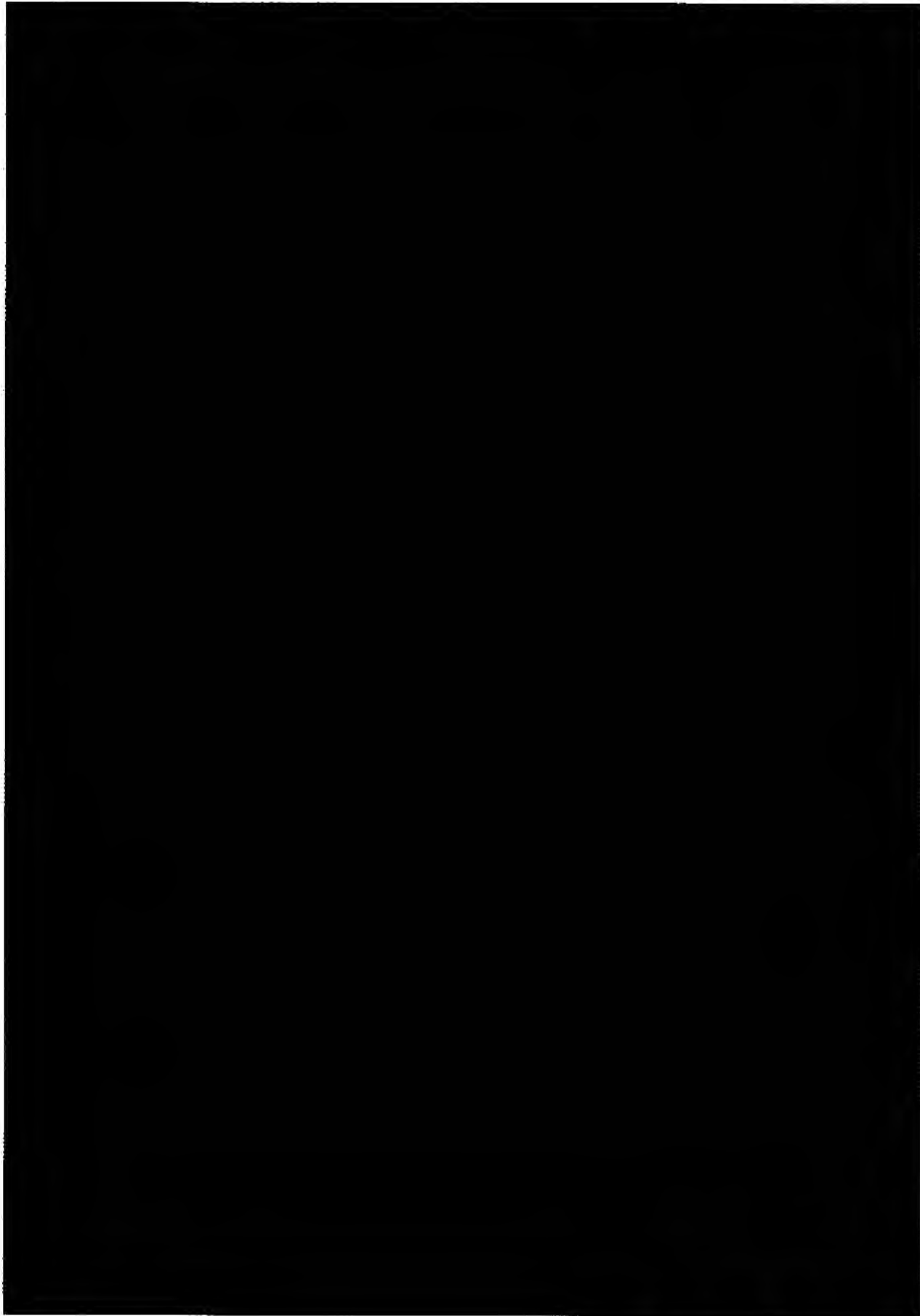
ARMY EQUIPMENT

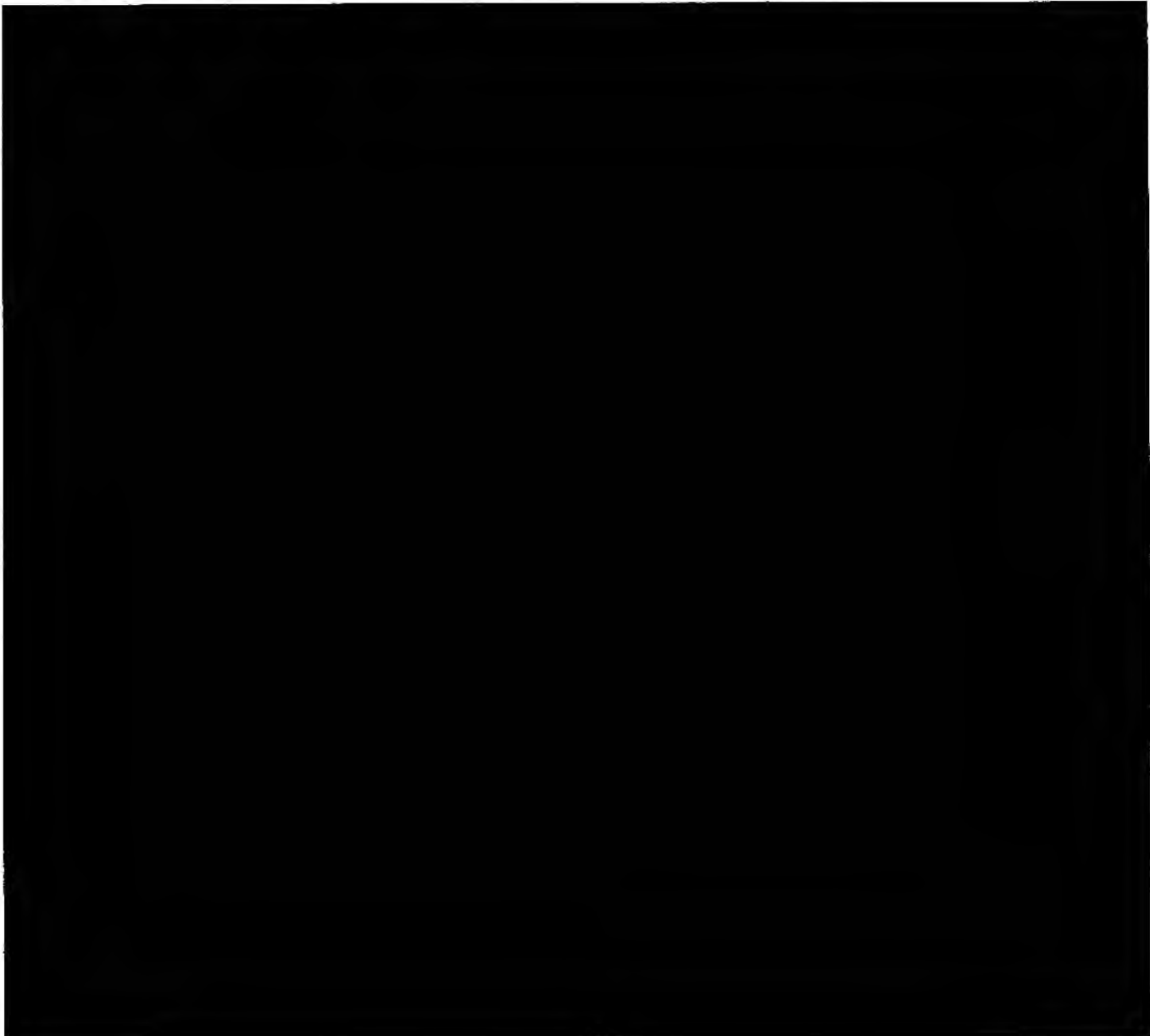
2320-D-122-302

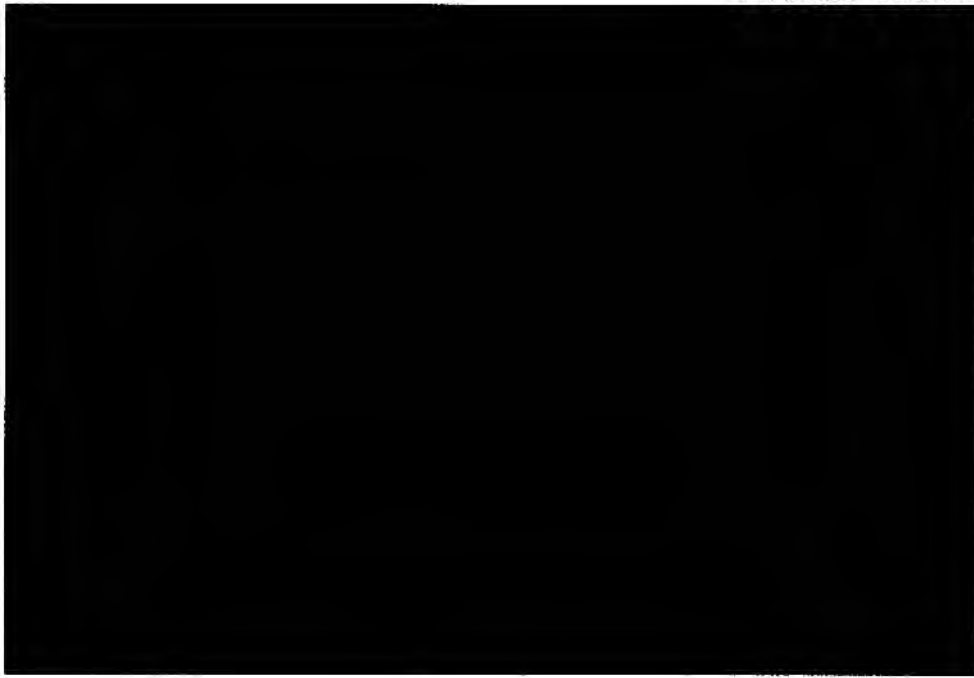


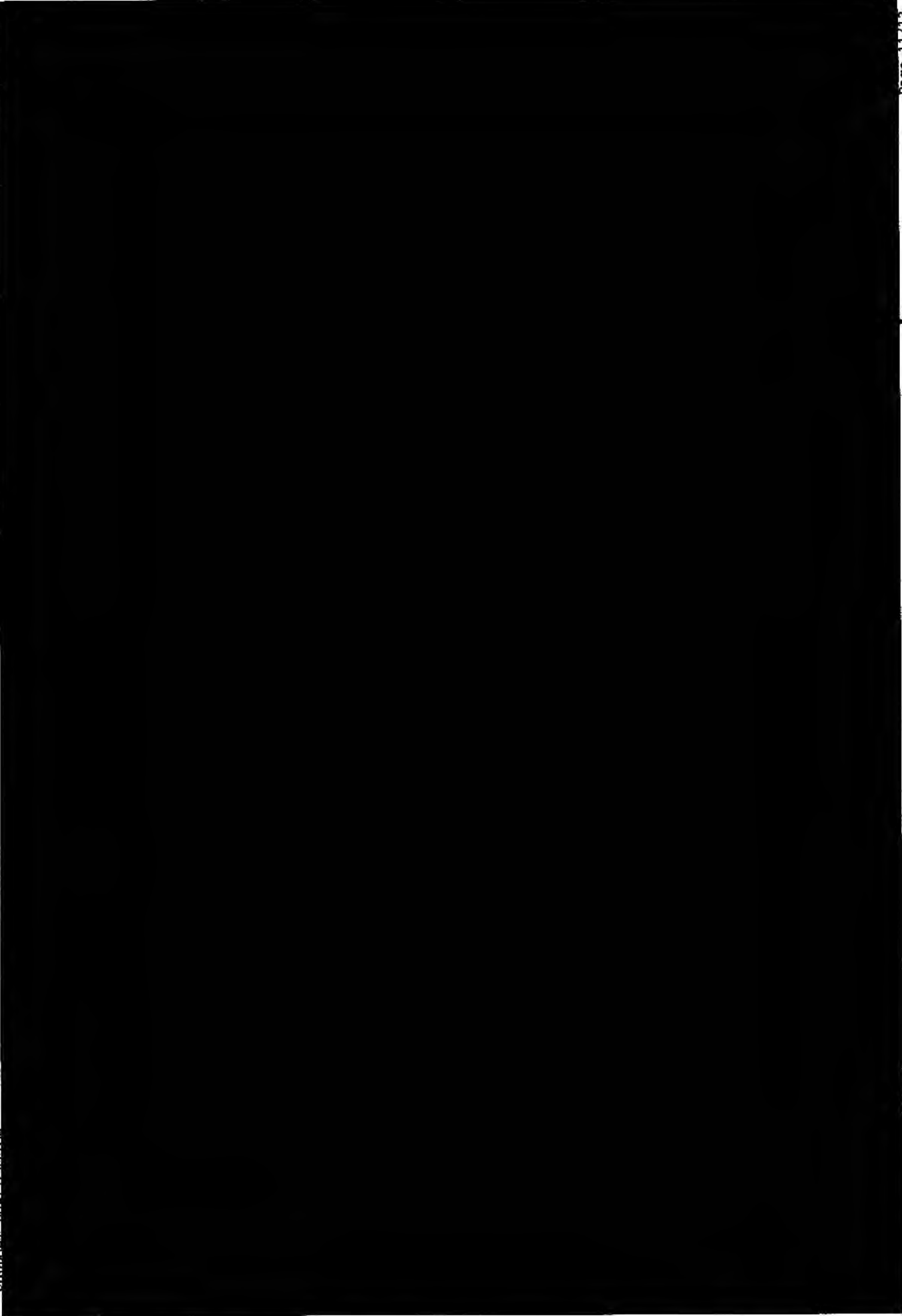


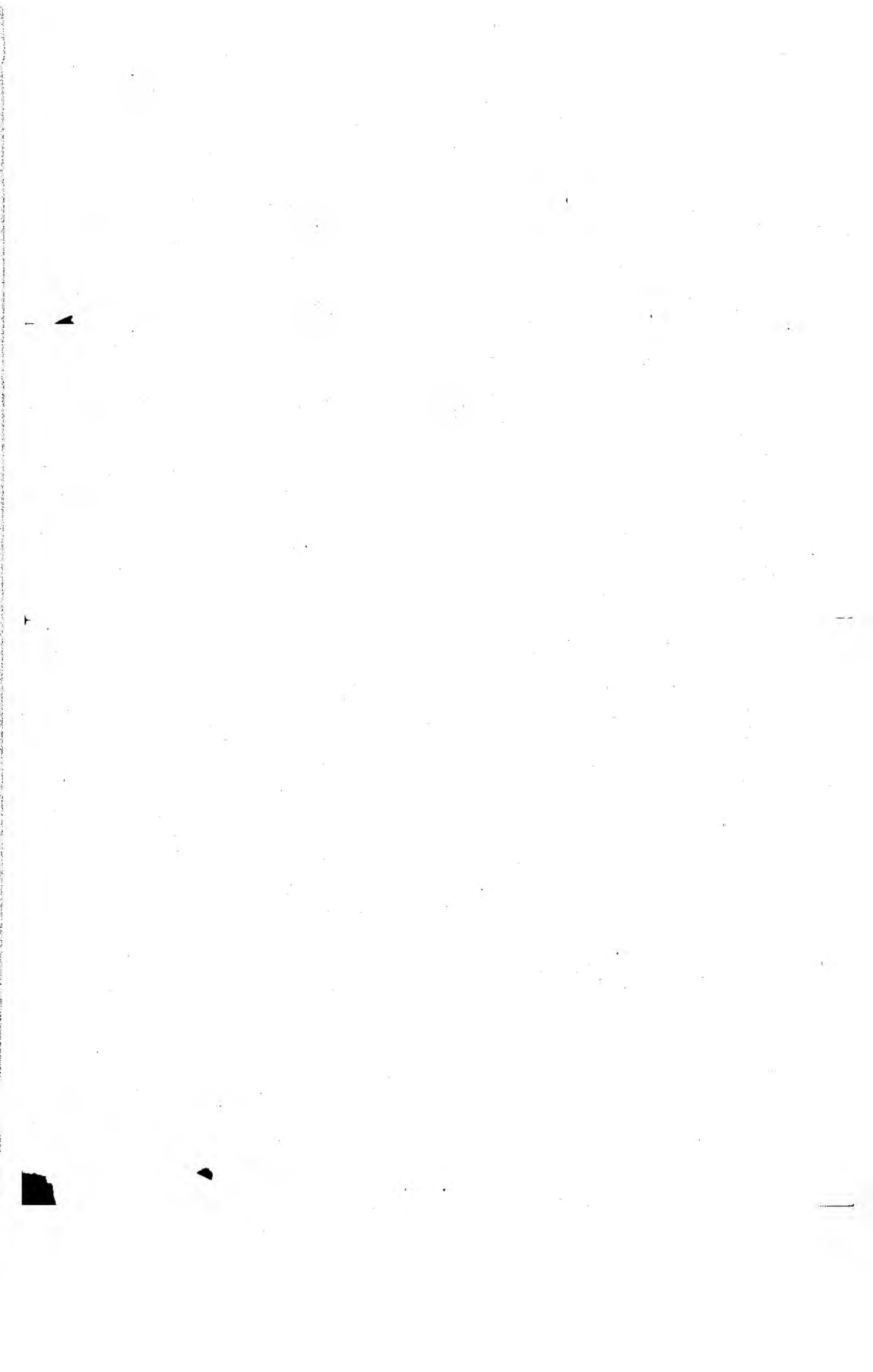


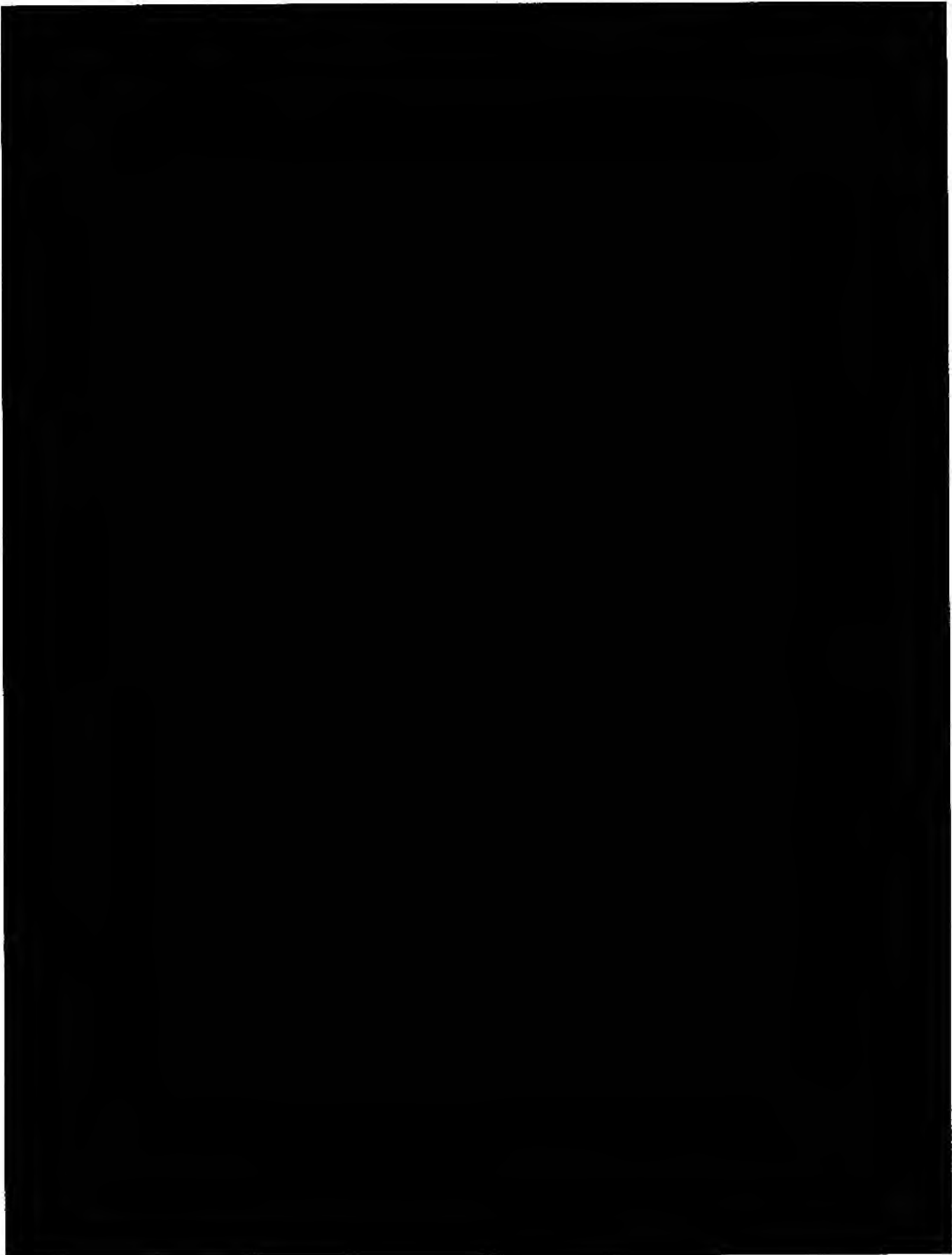


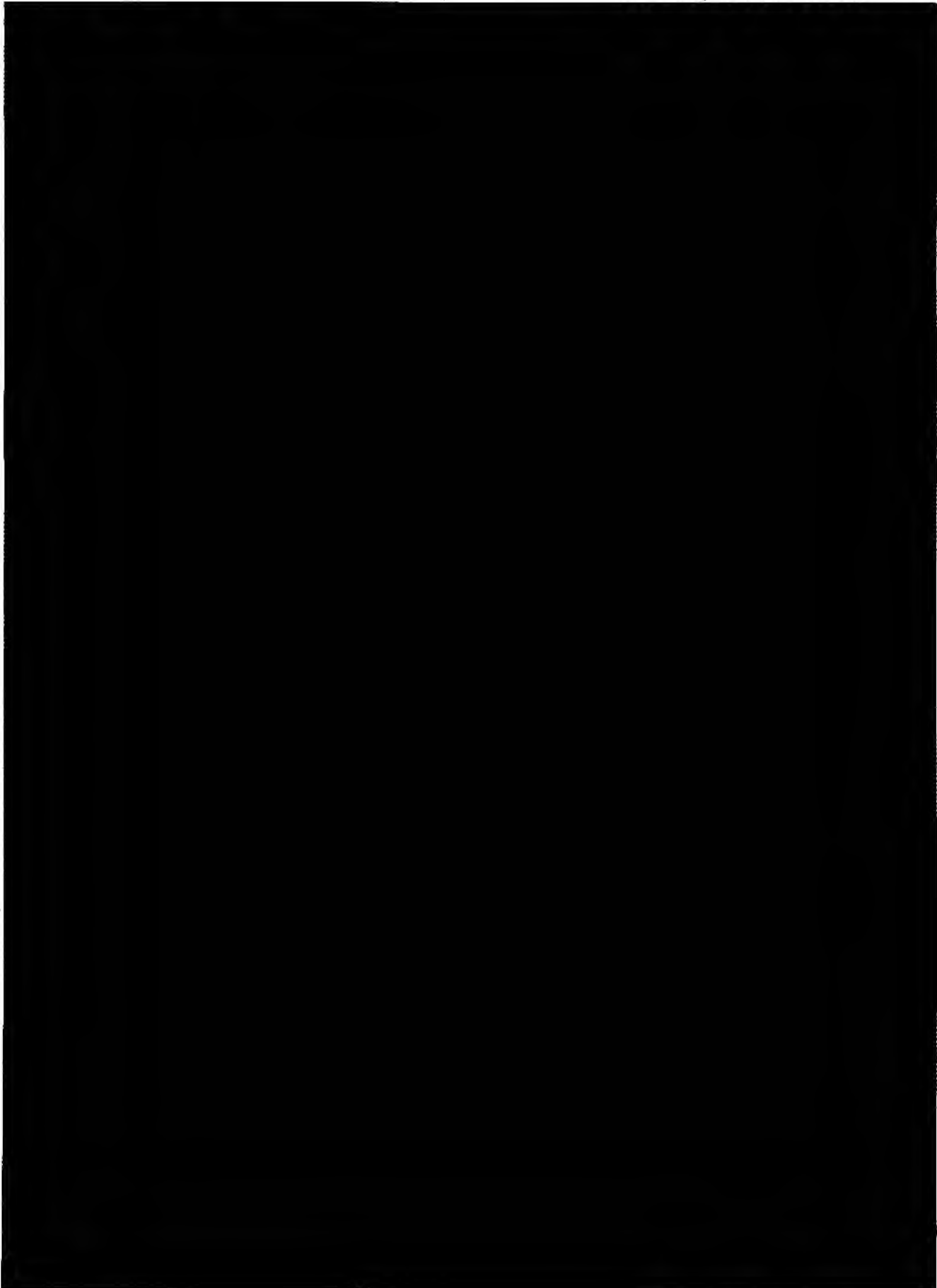


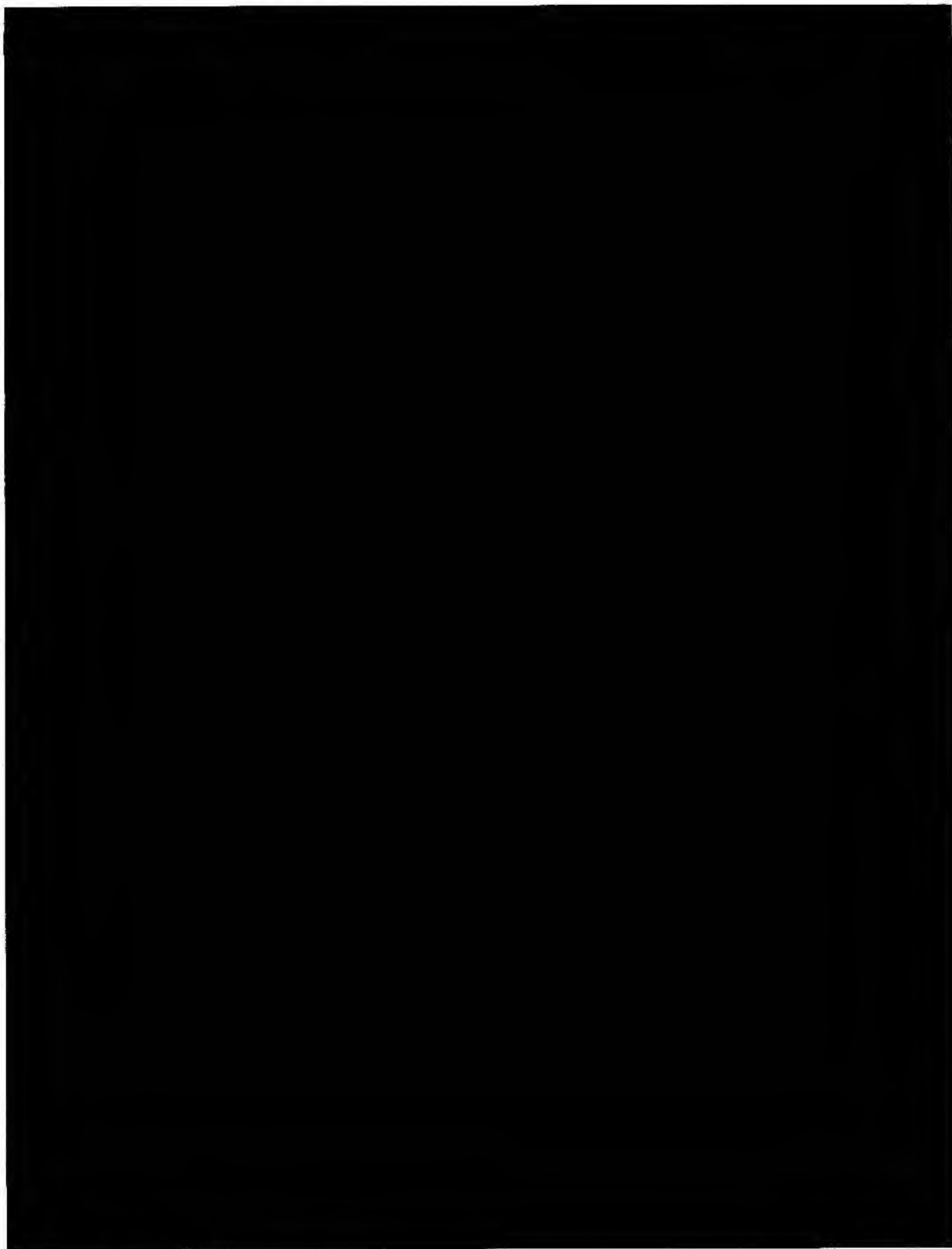


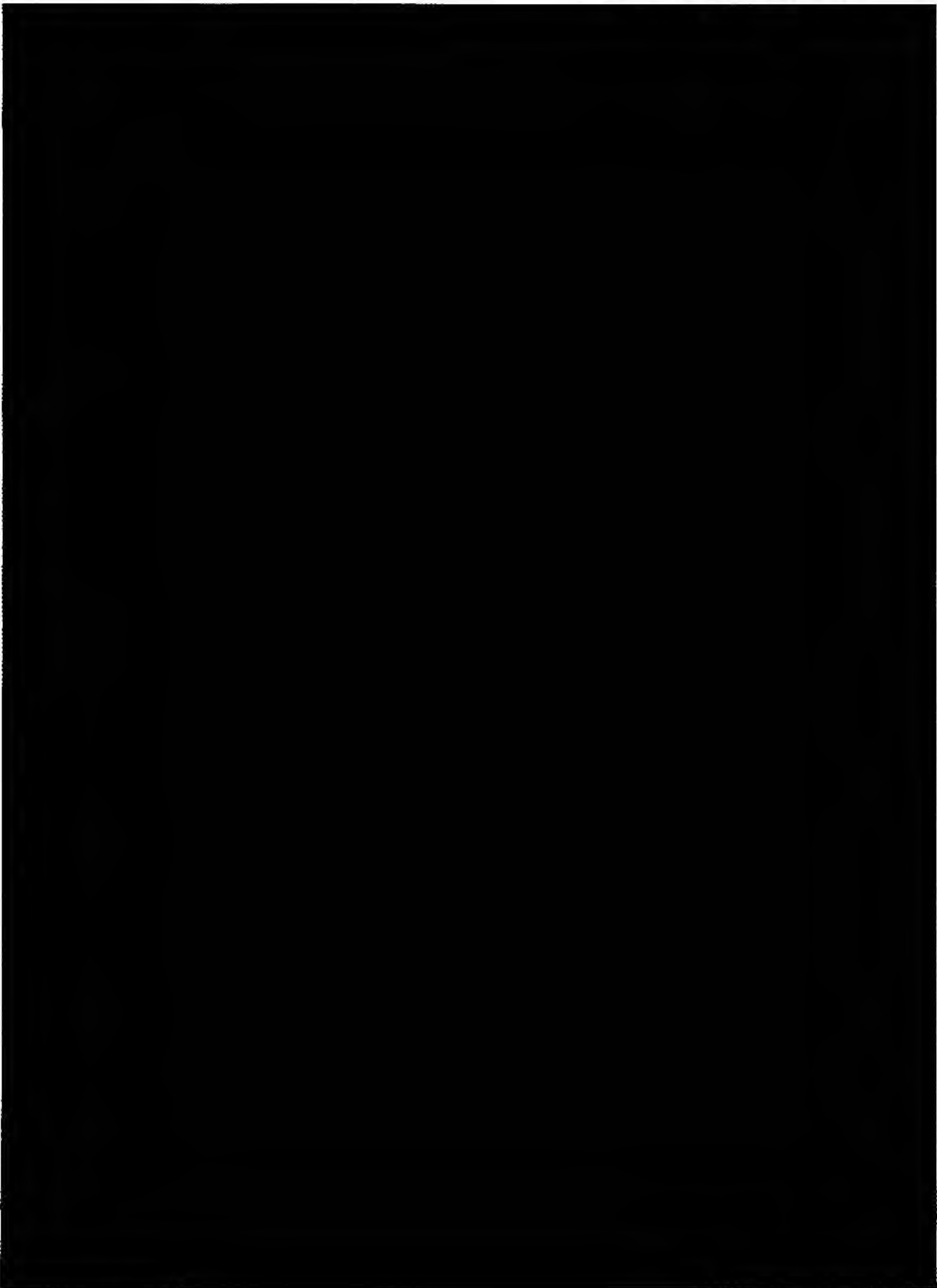


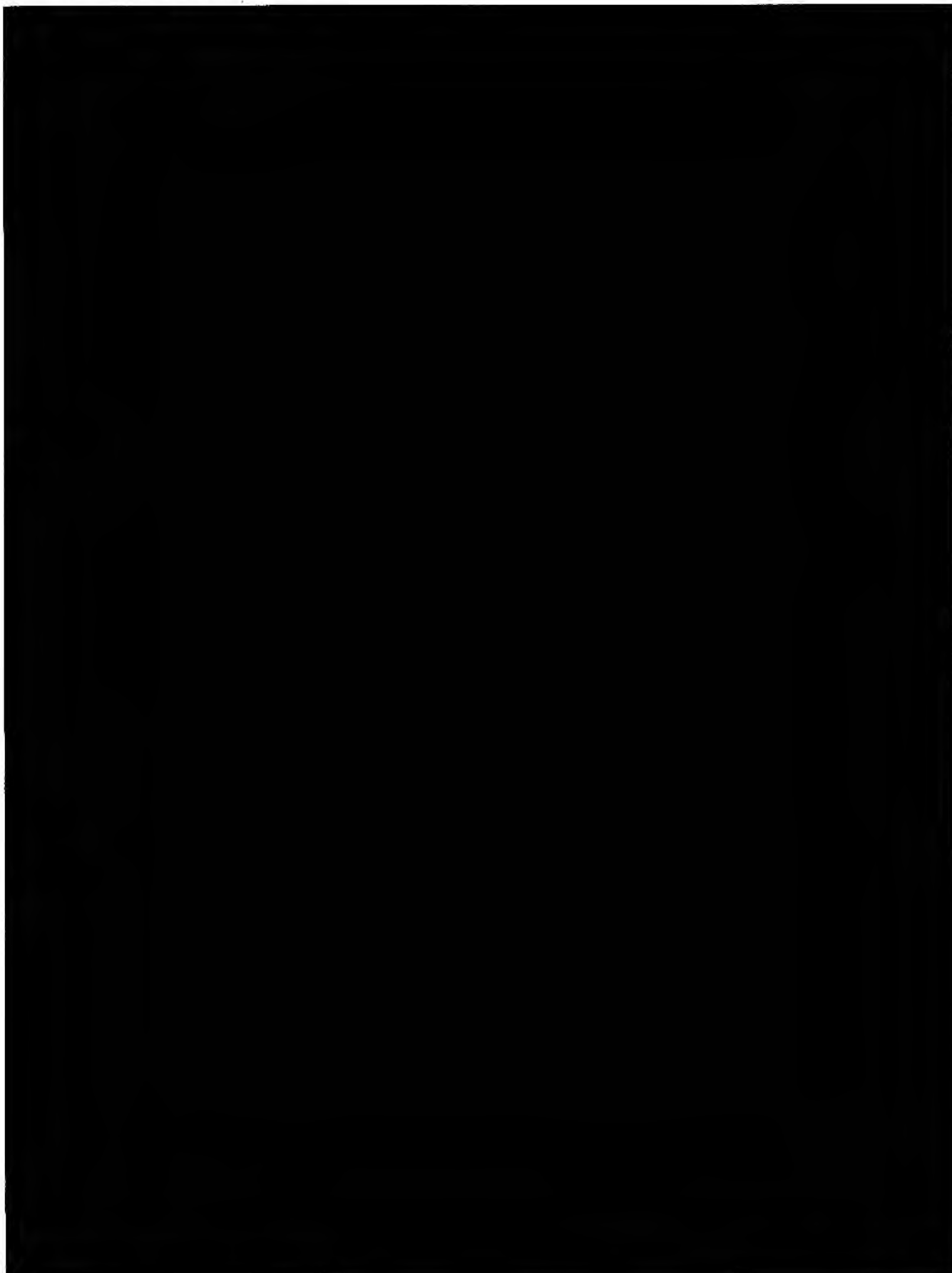


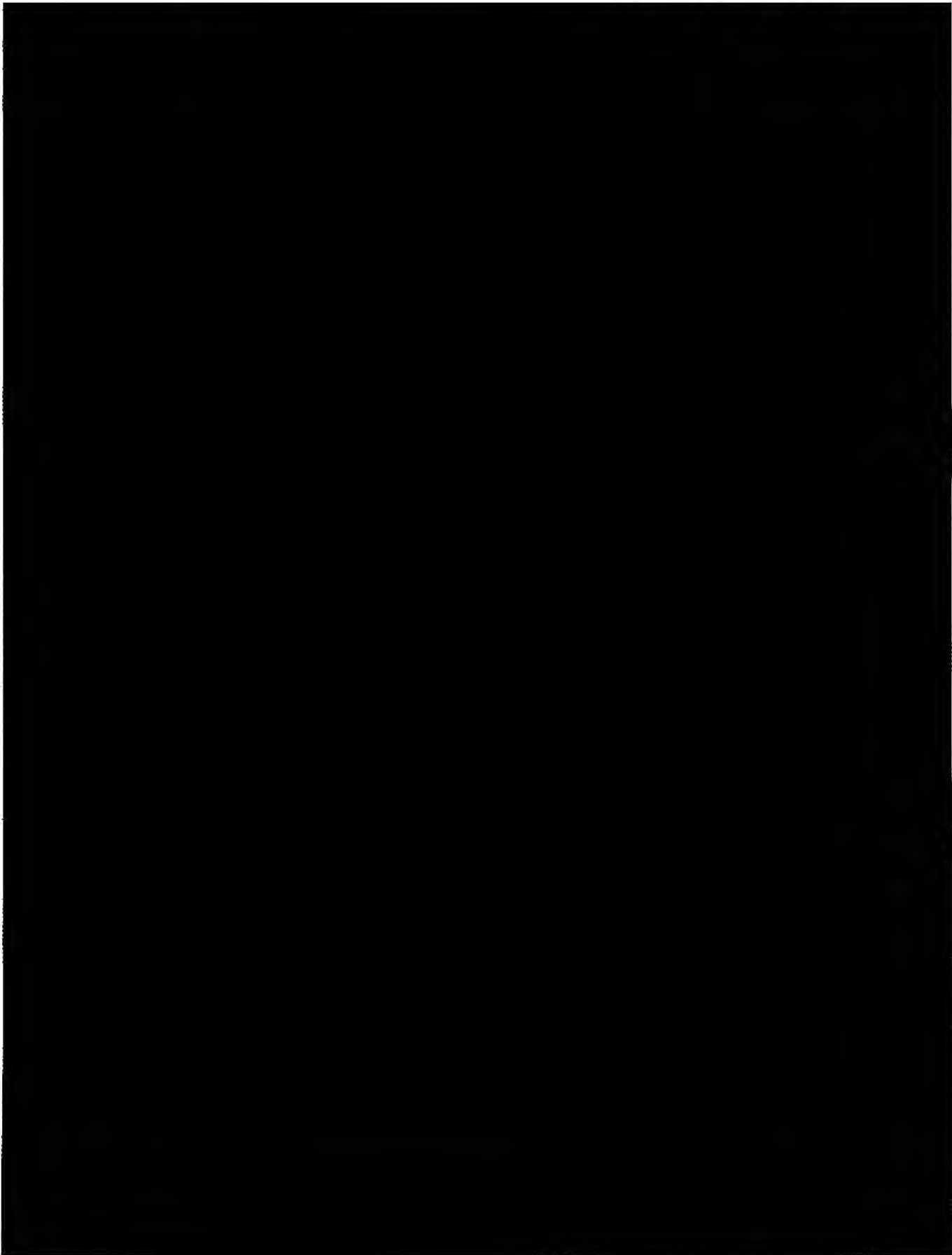


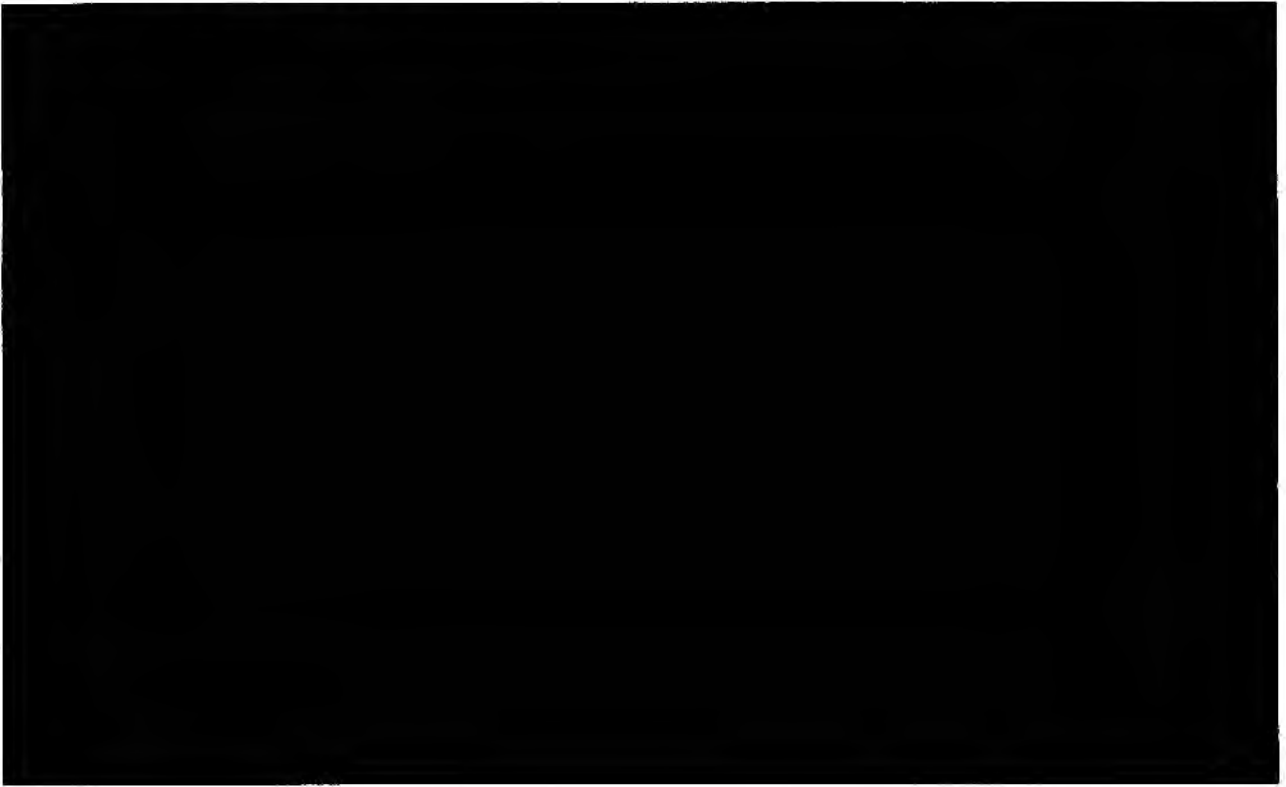


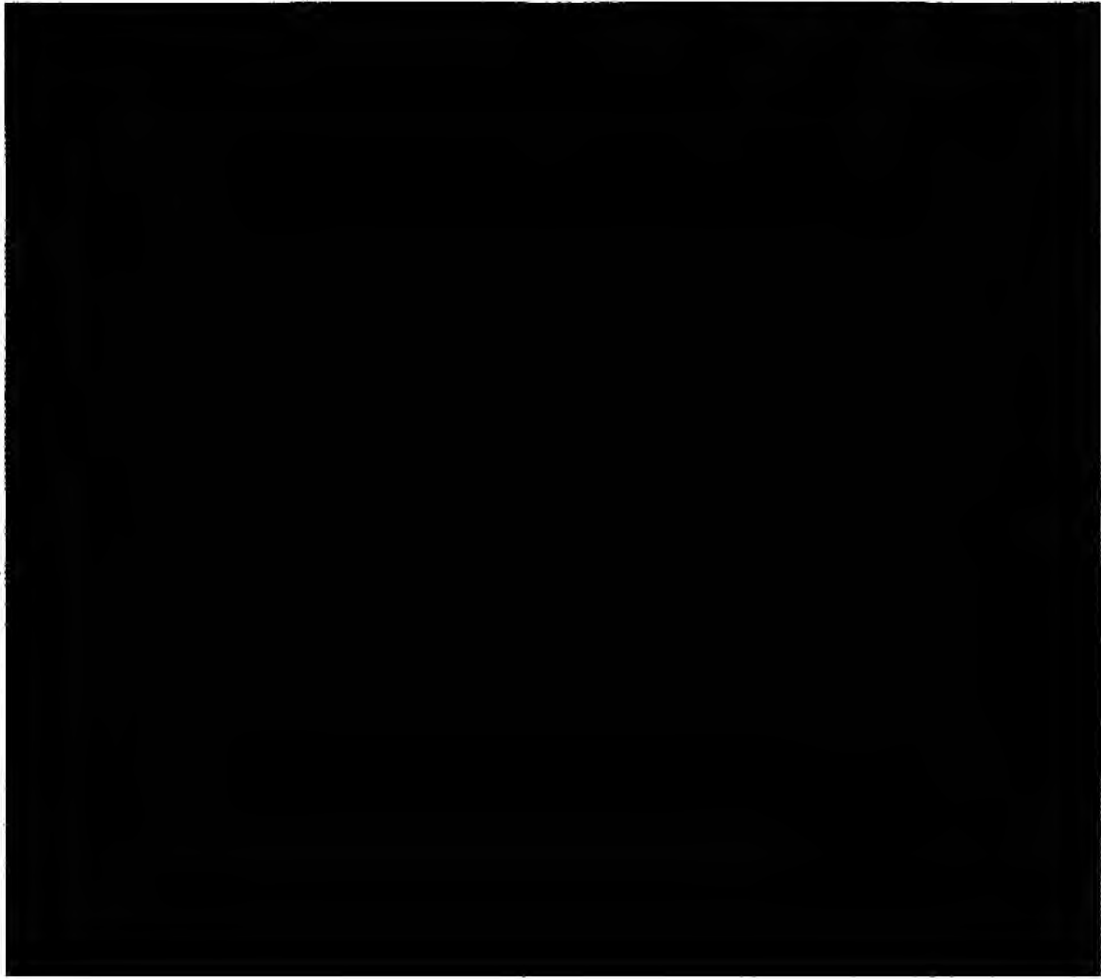








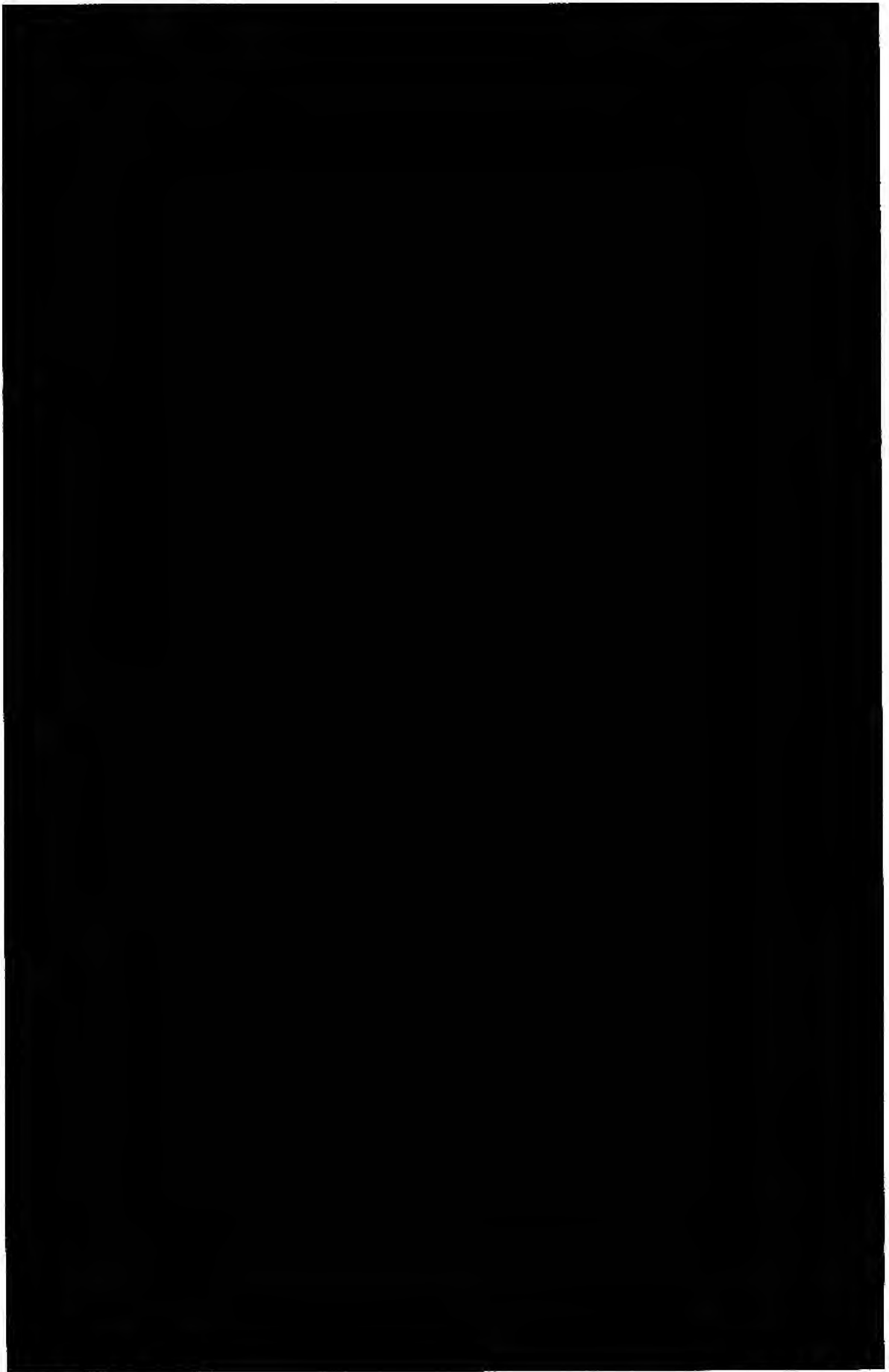




ARMY EQUIPMENT
SUPPORT PUBLICATION

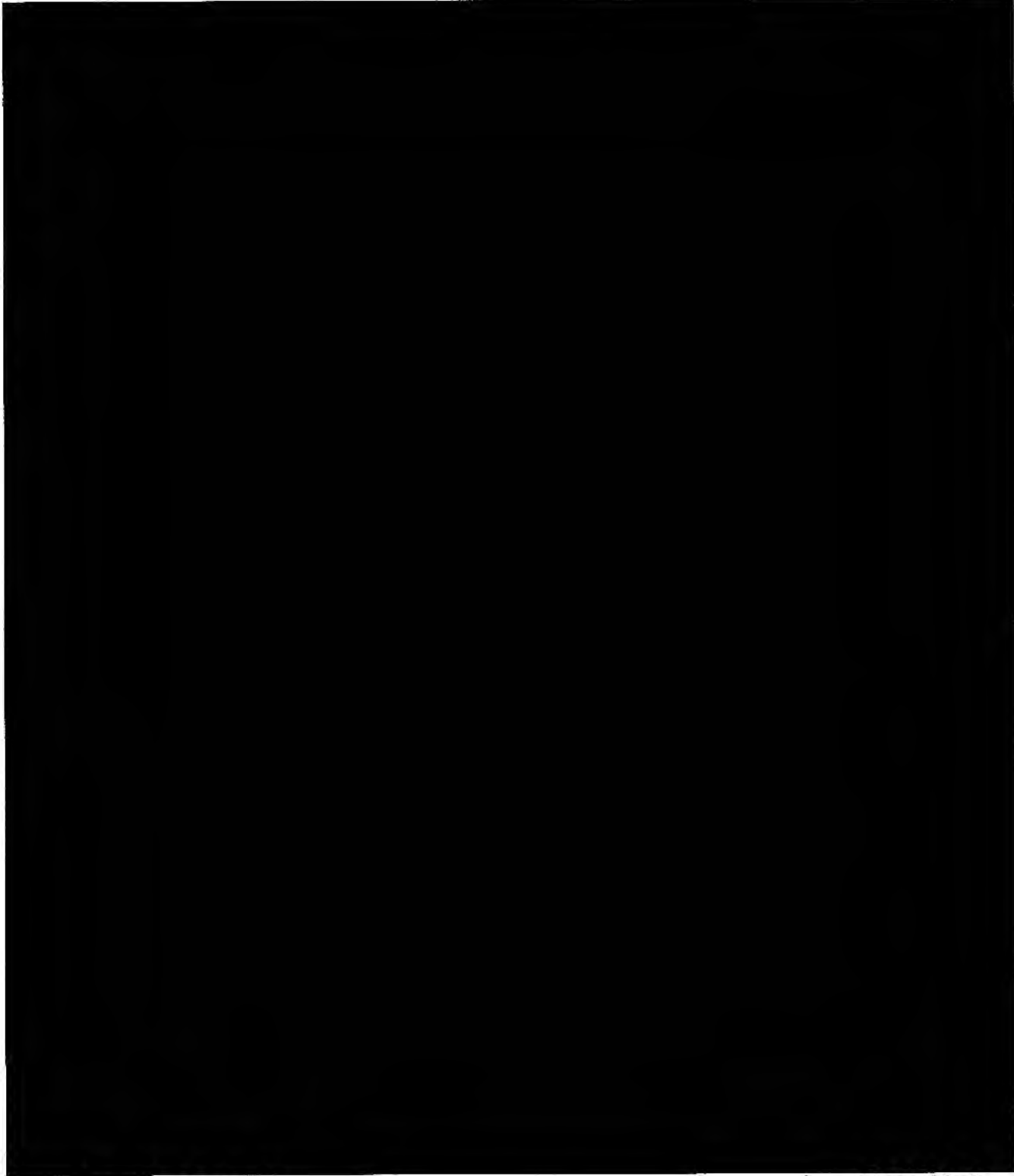
2320-D-122-302

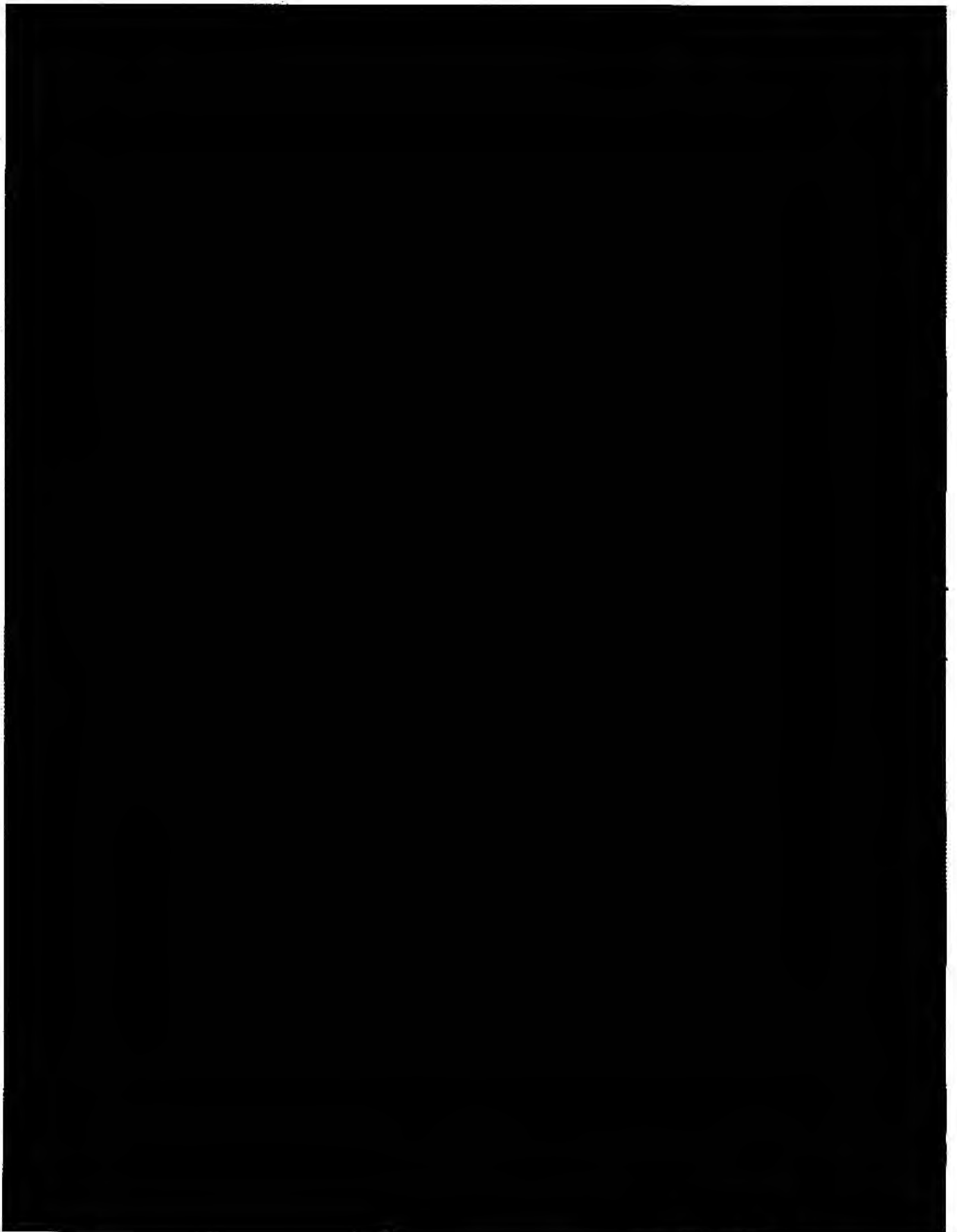


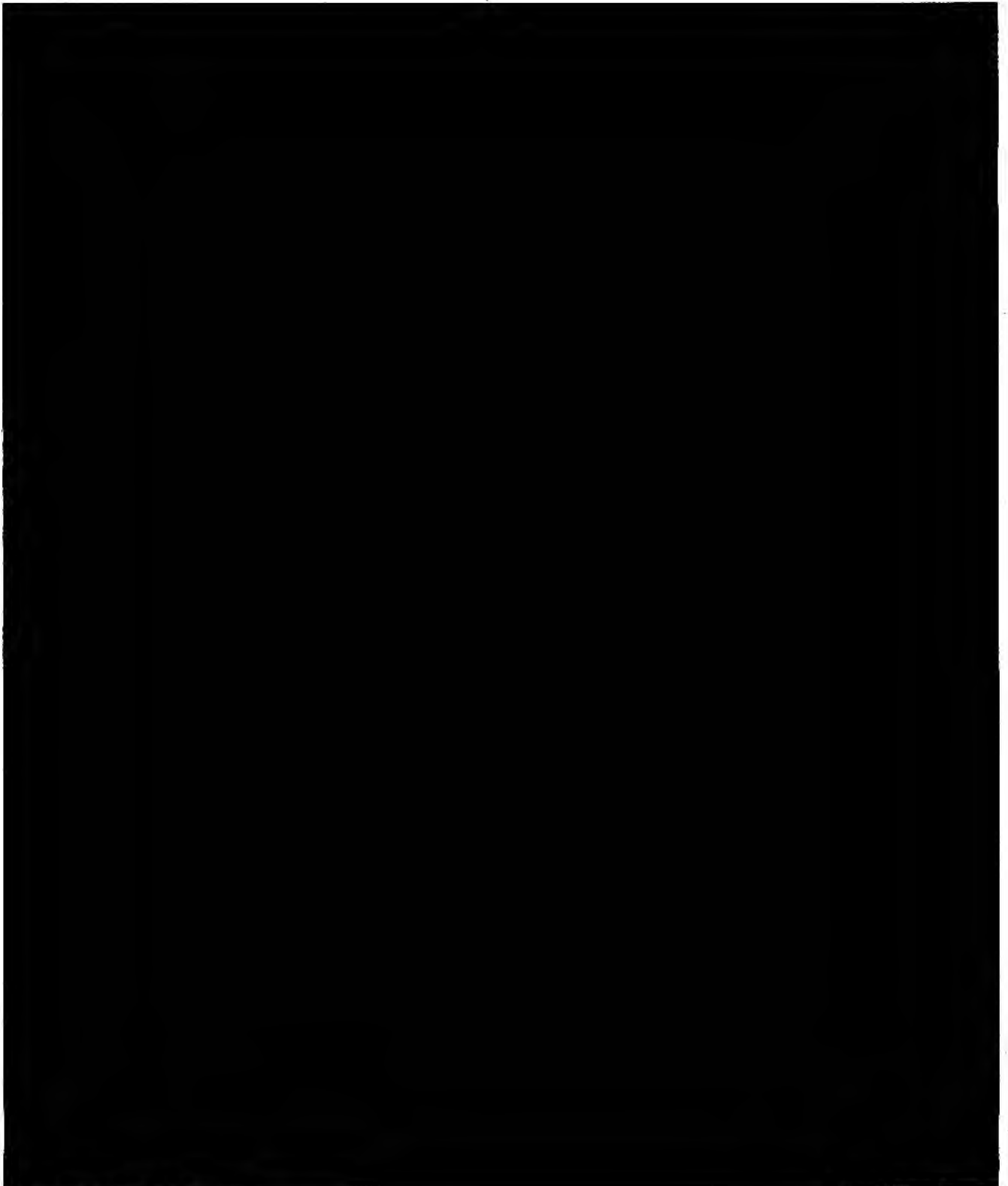


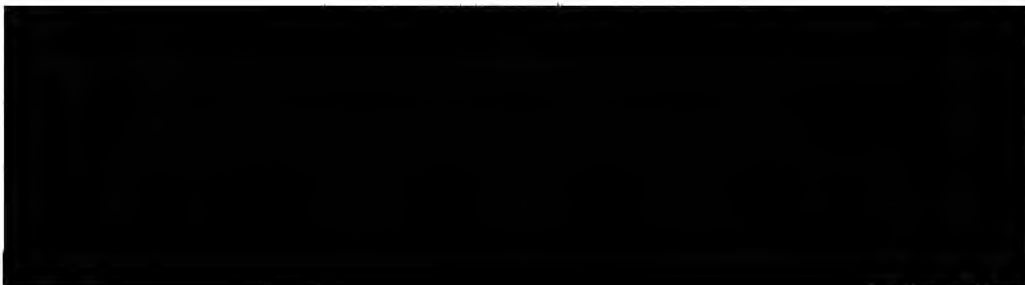


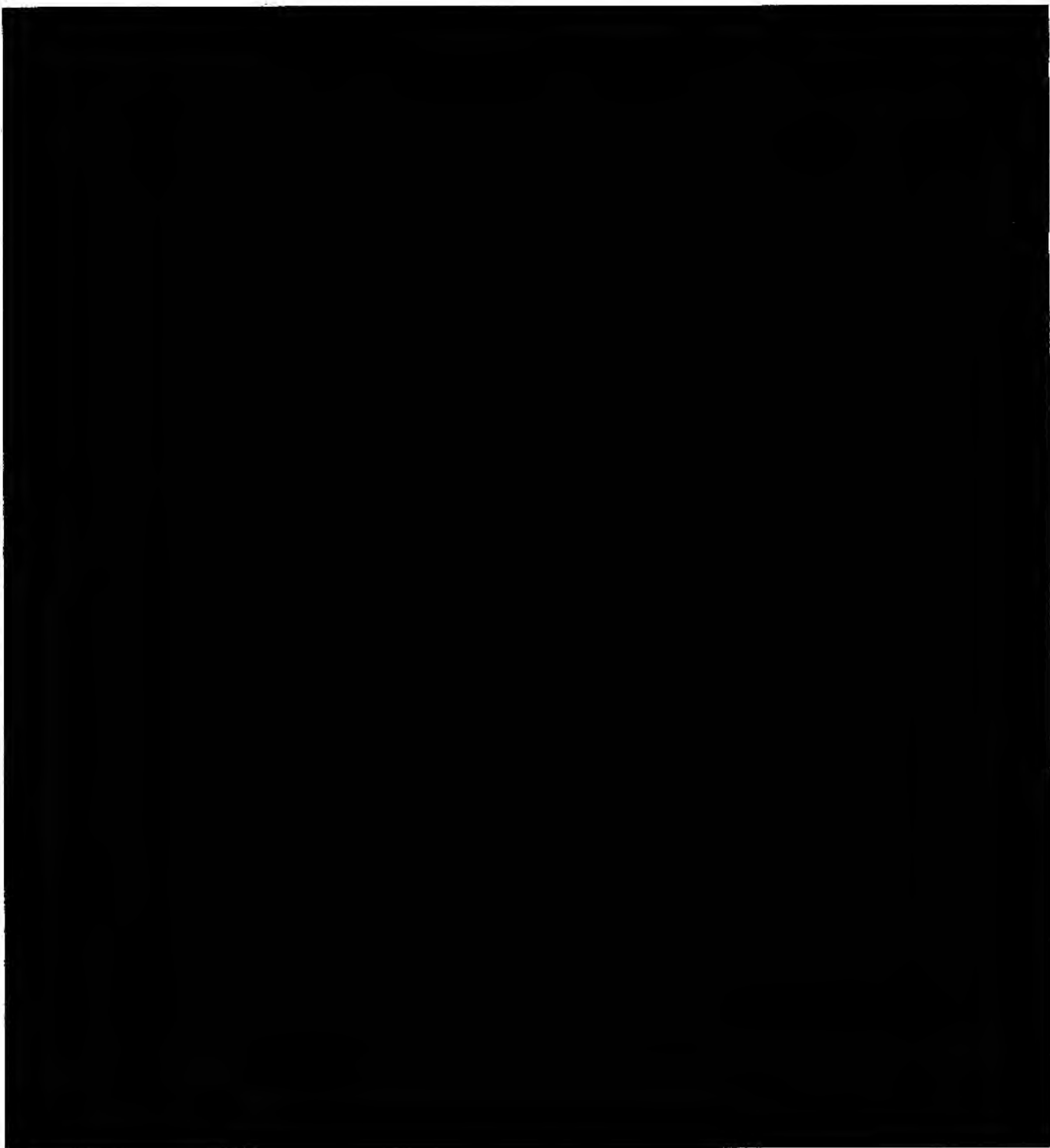


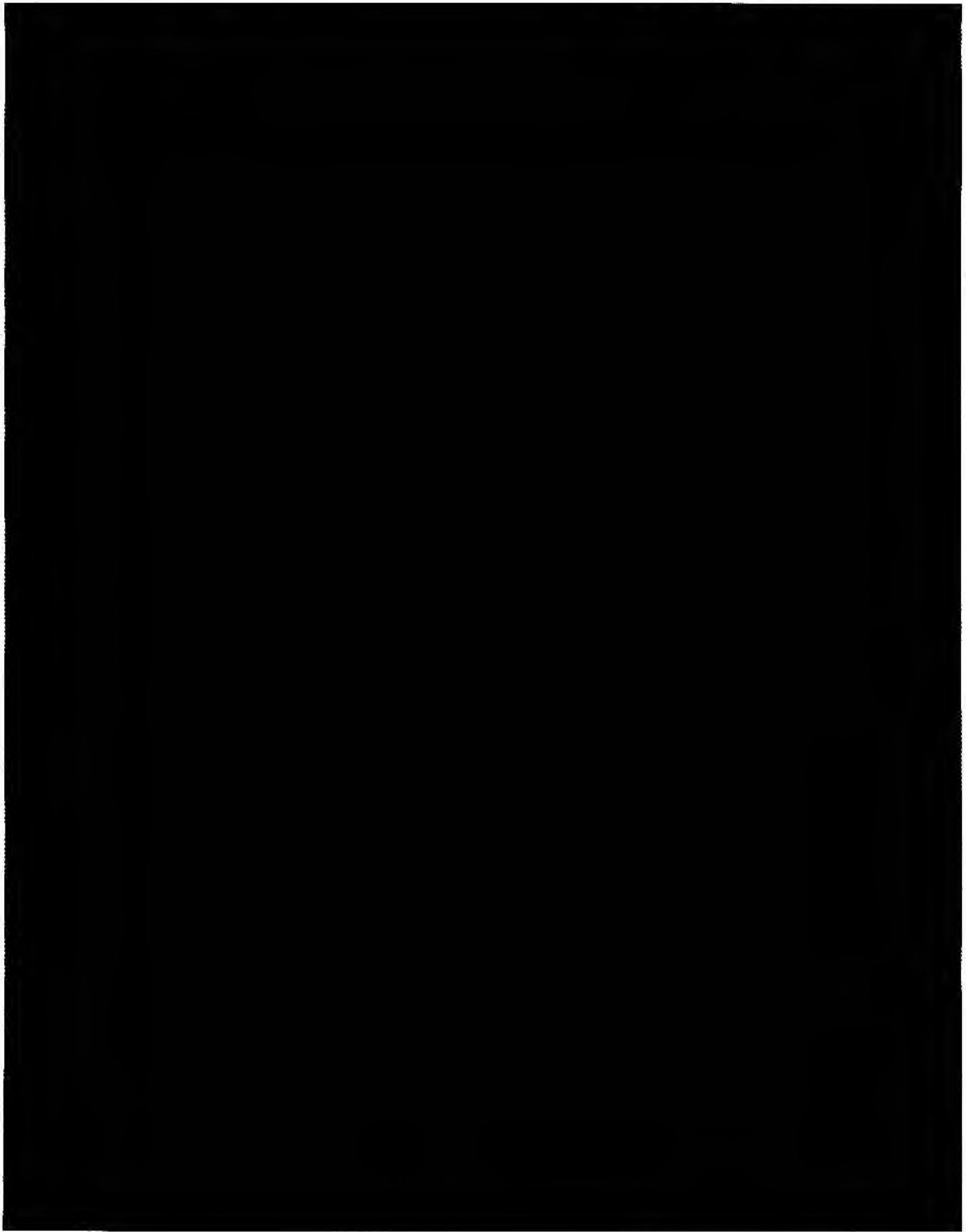




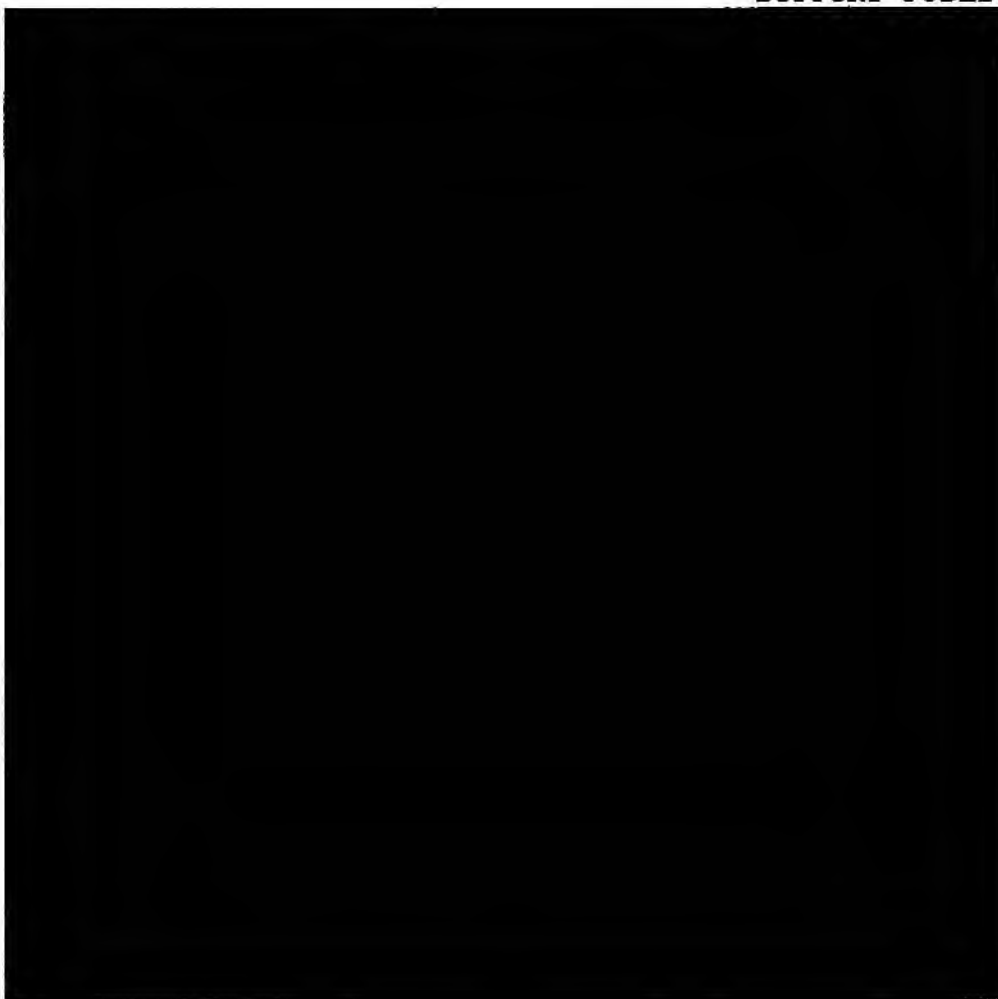


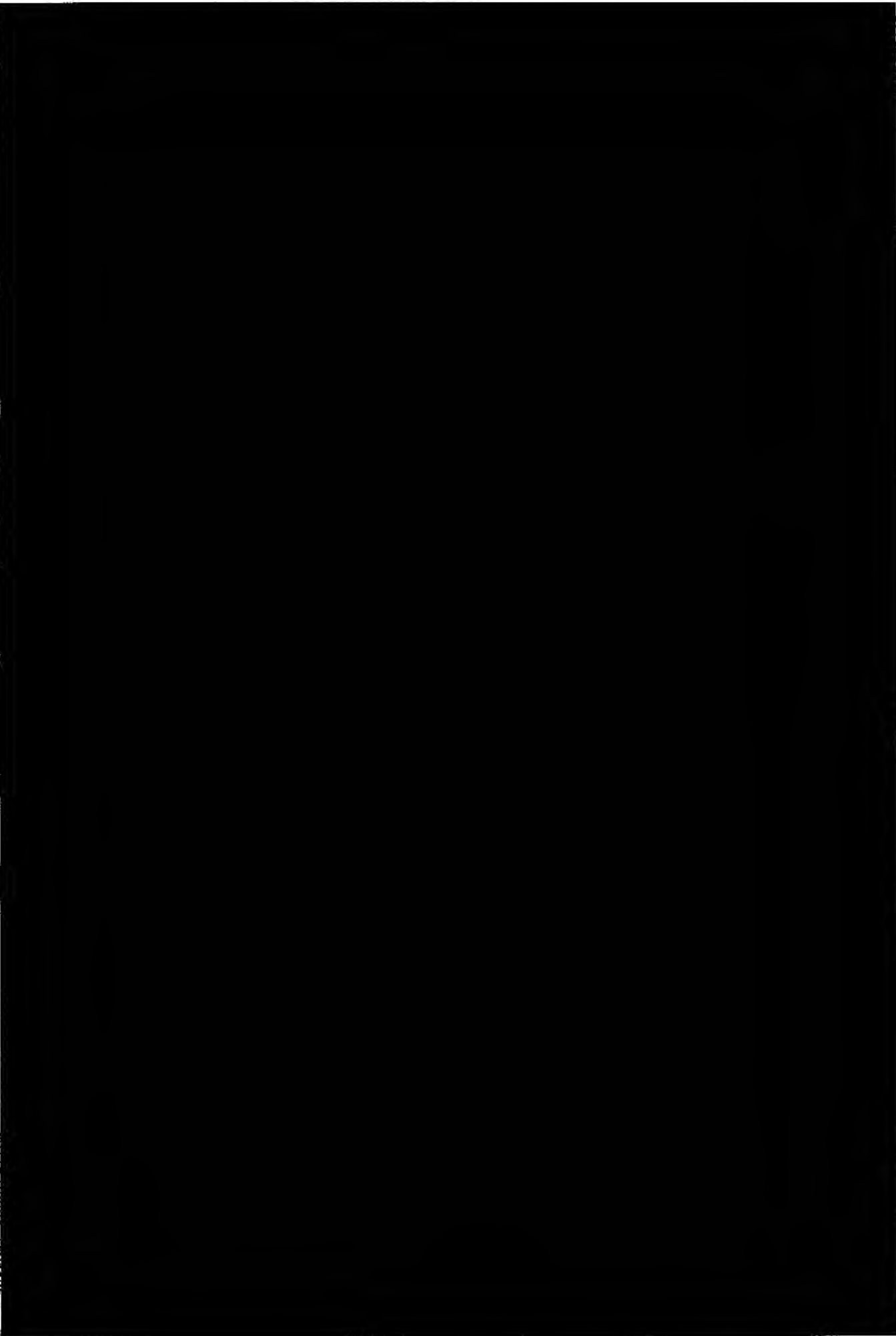


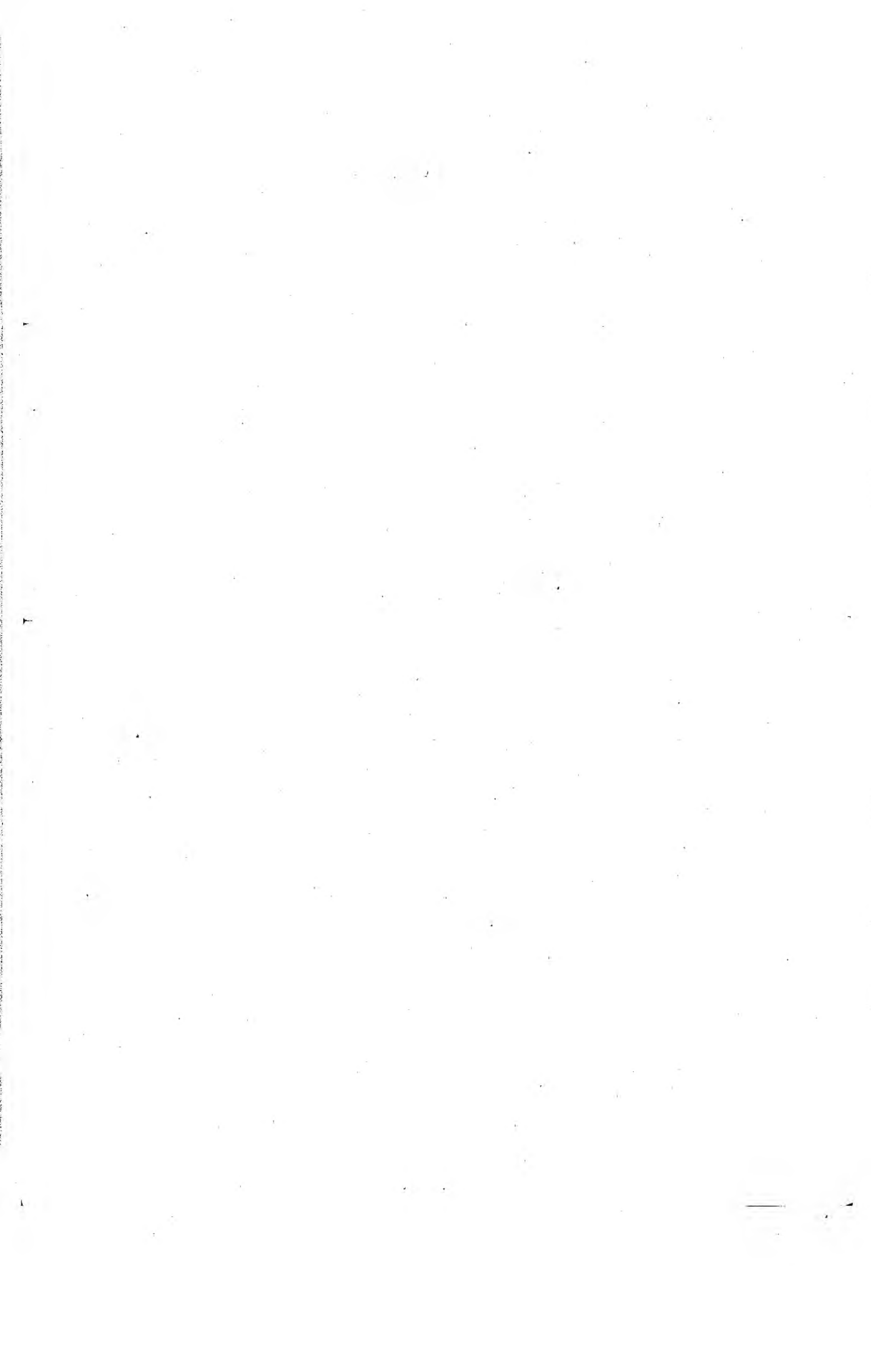


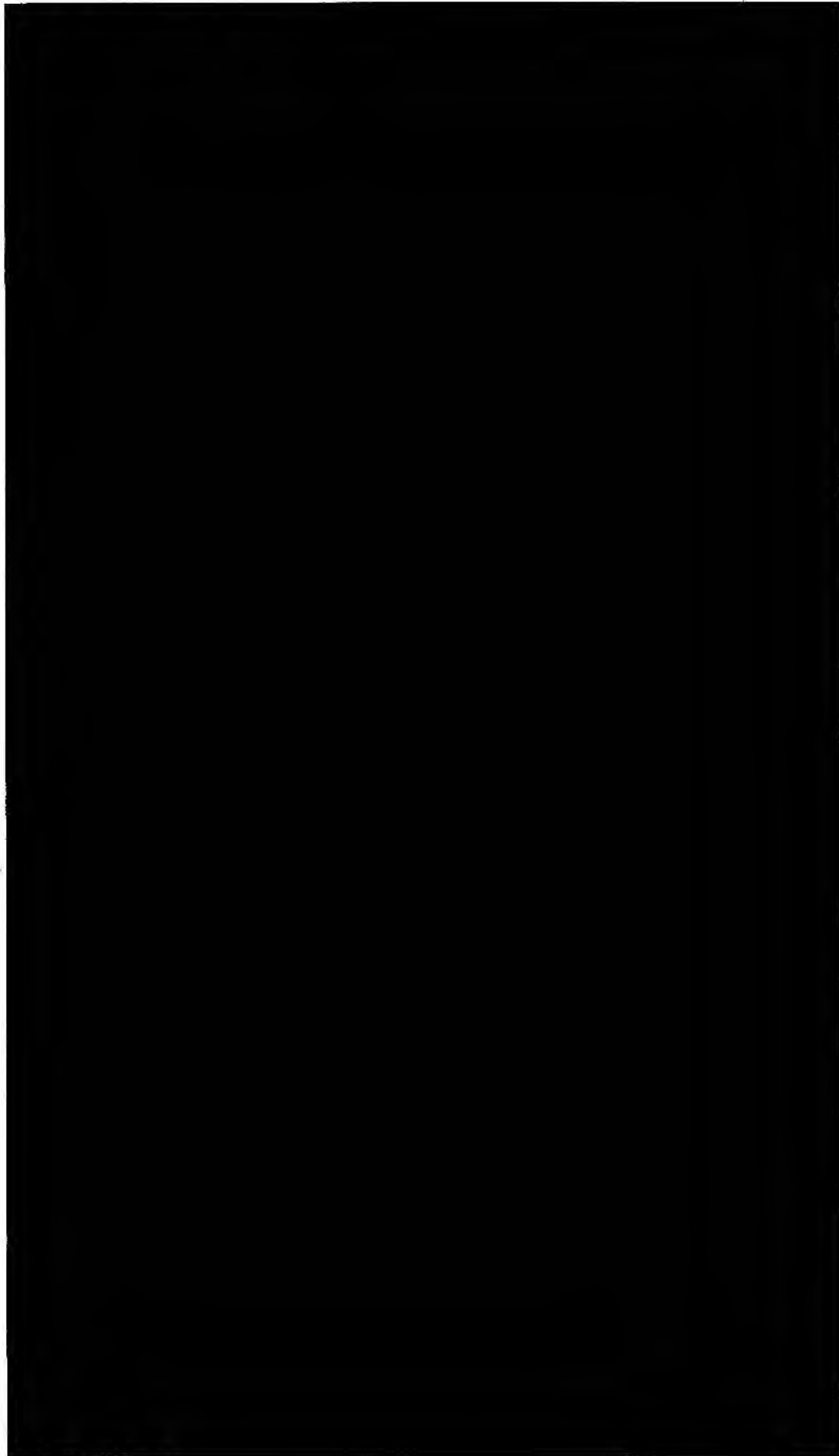


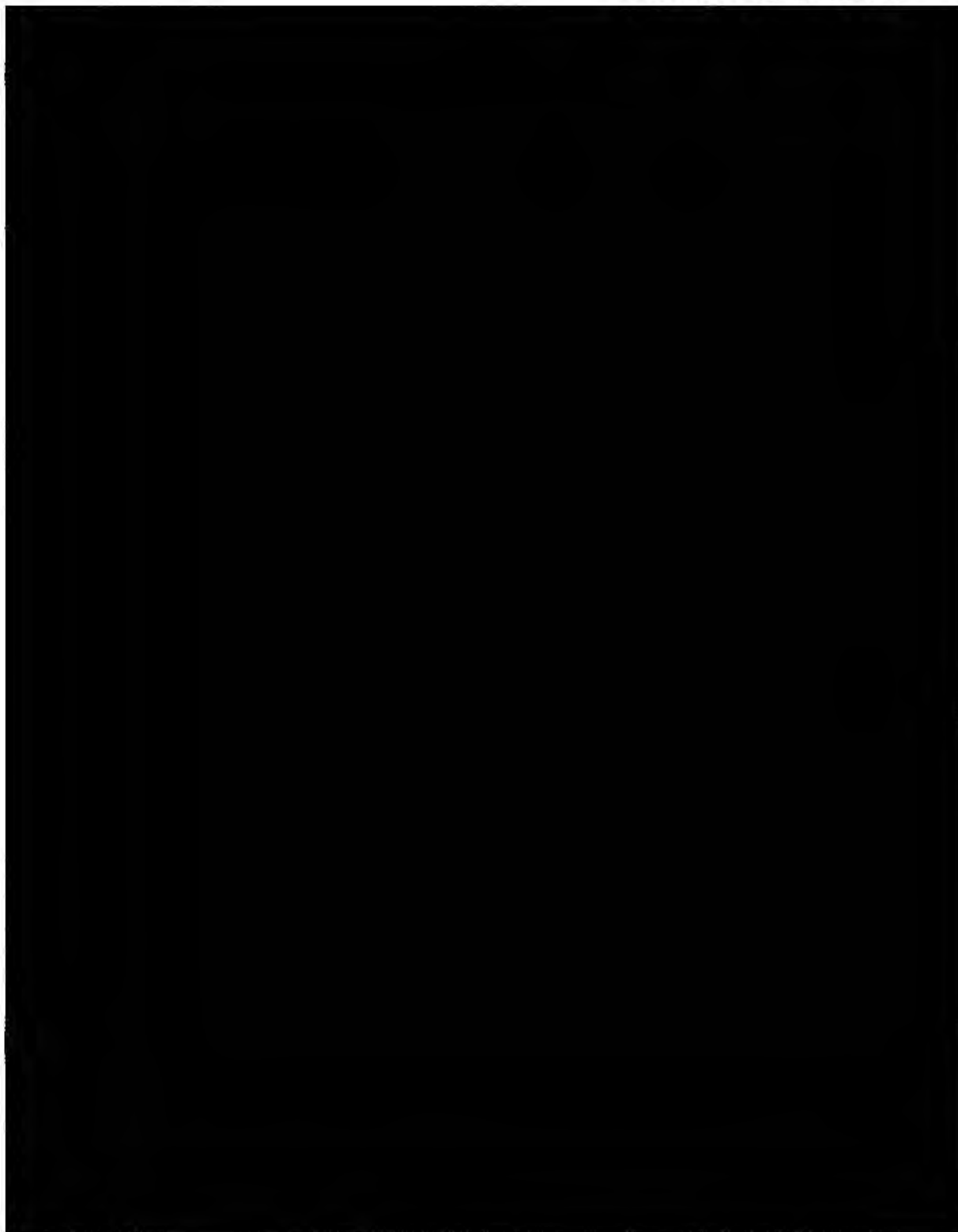












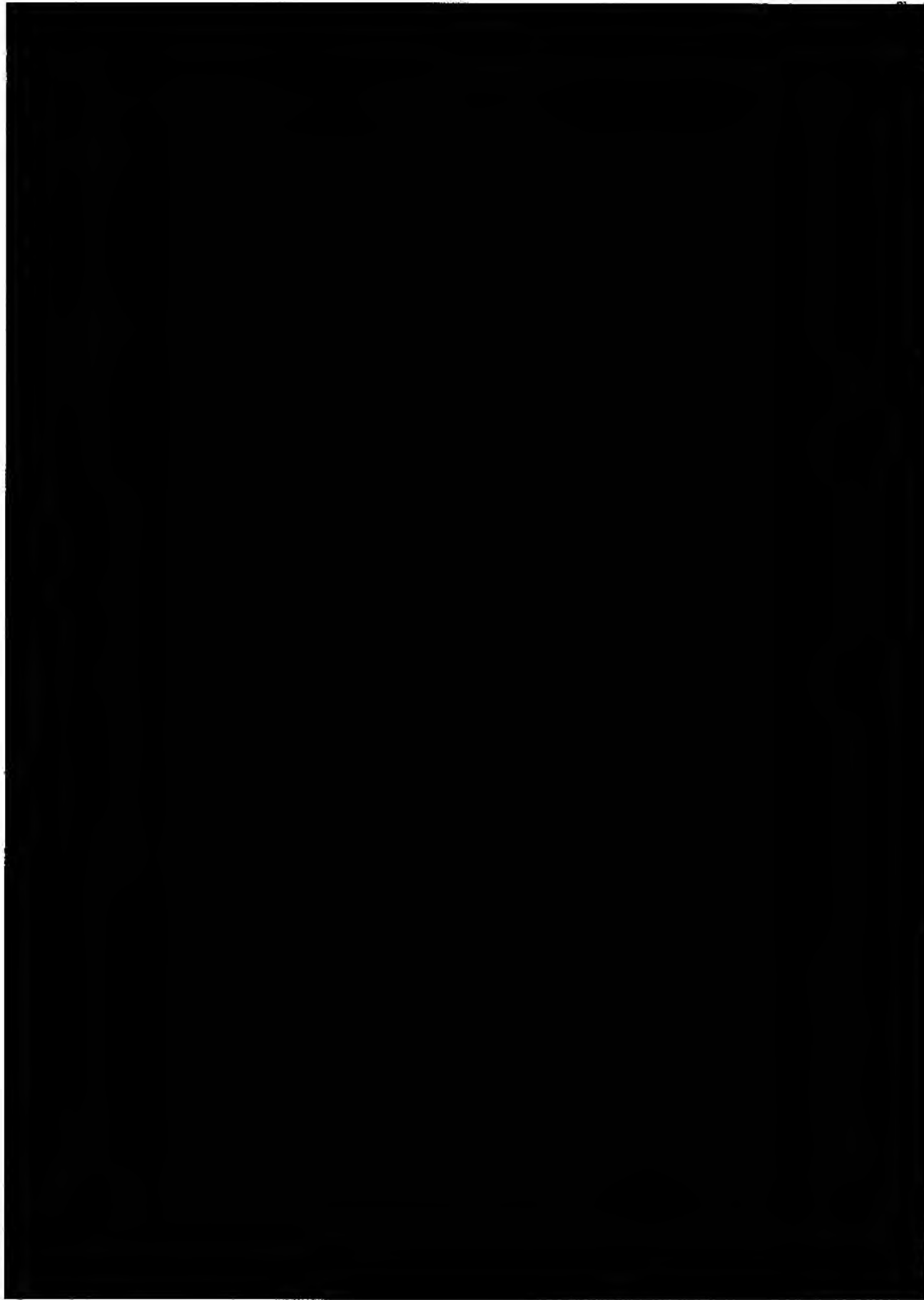
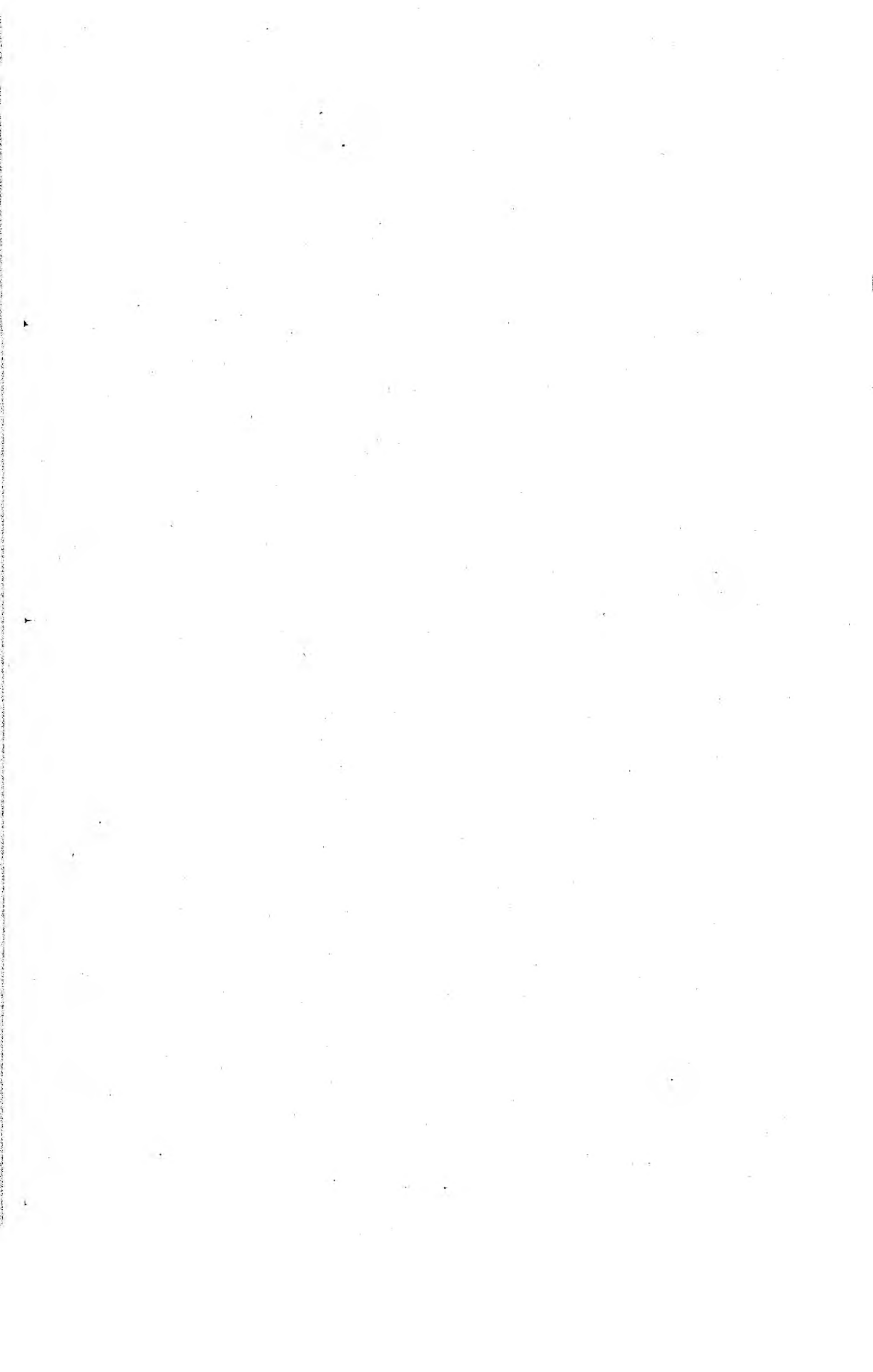
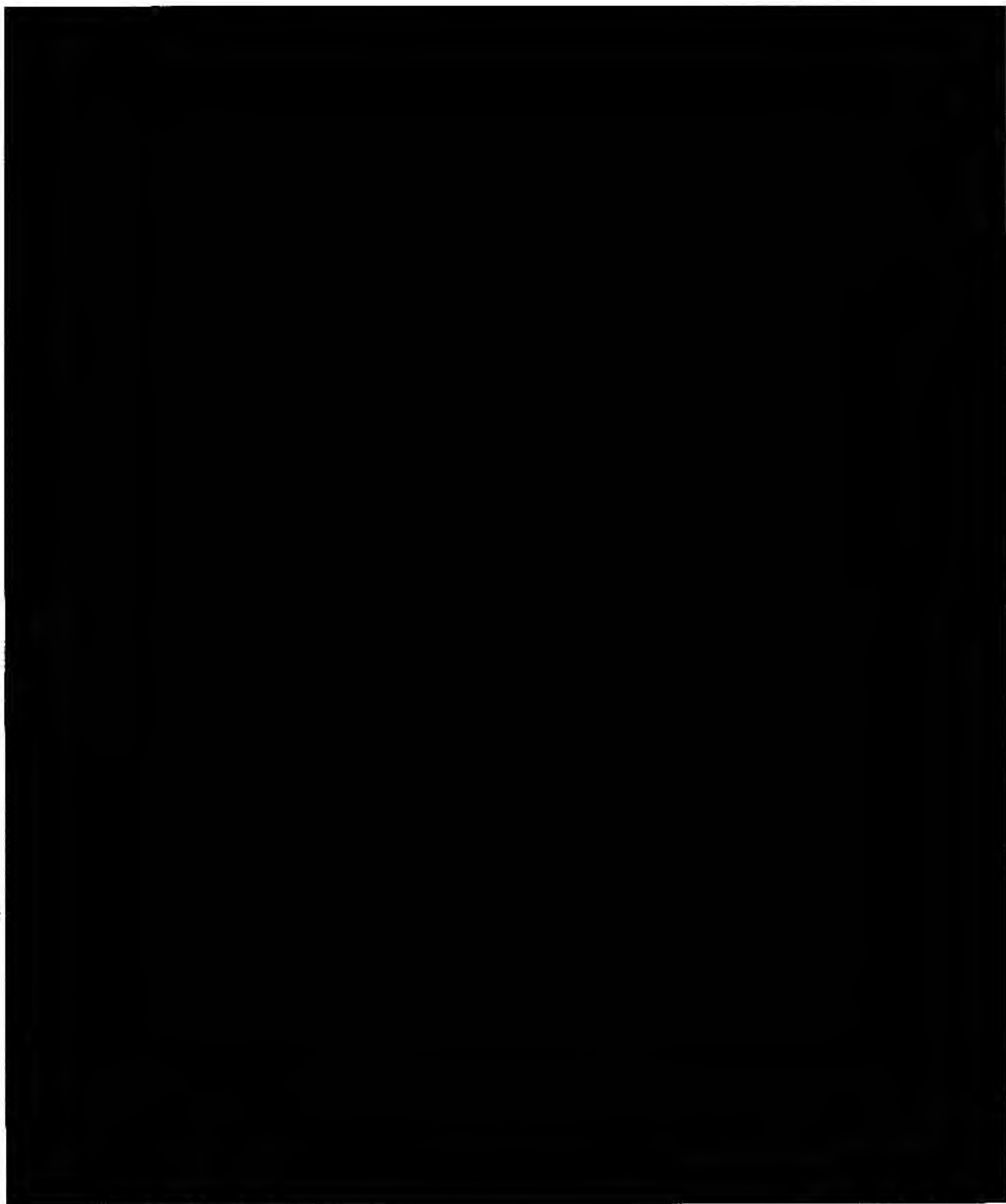
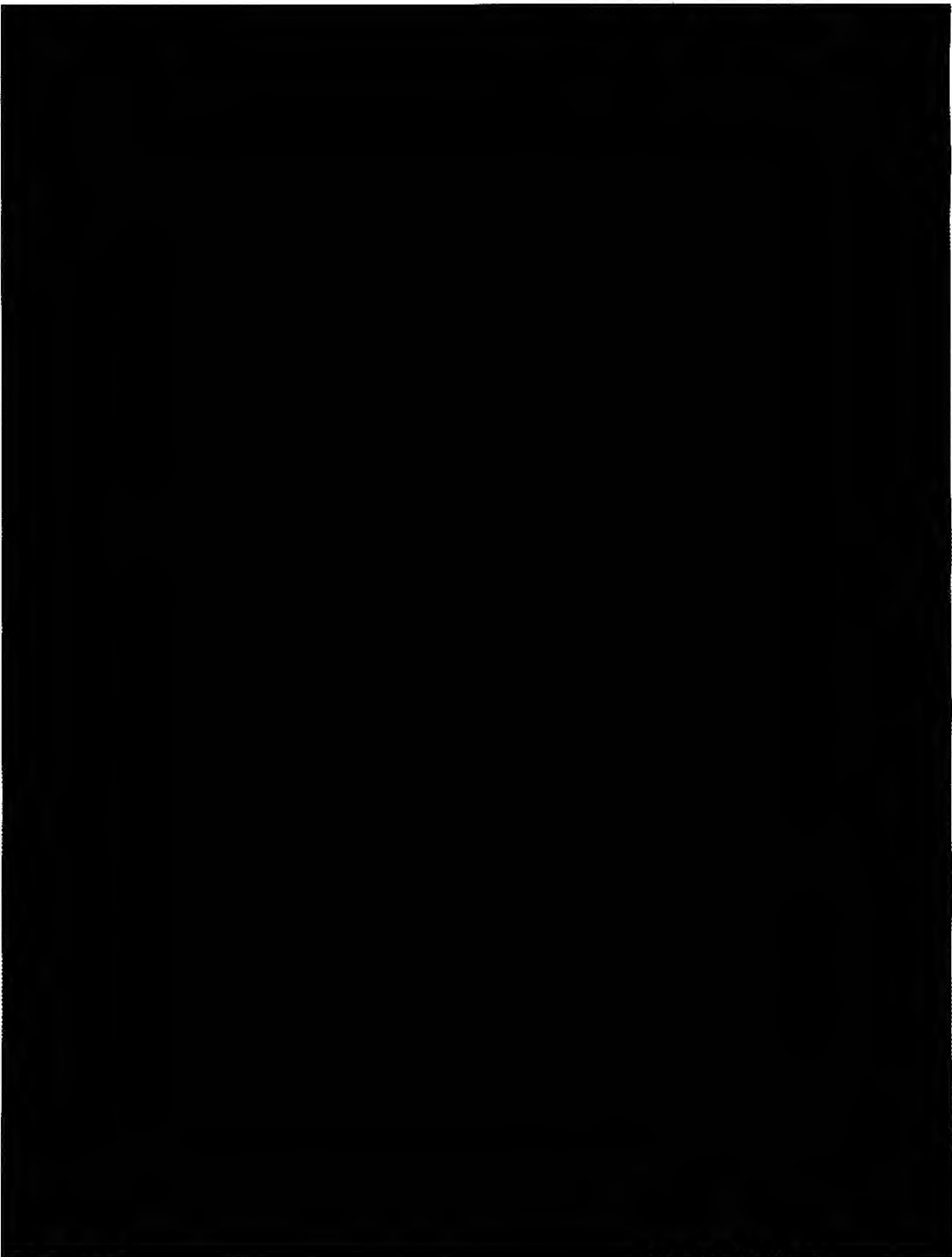


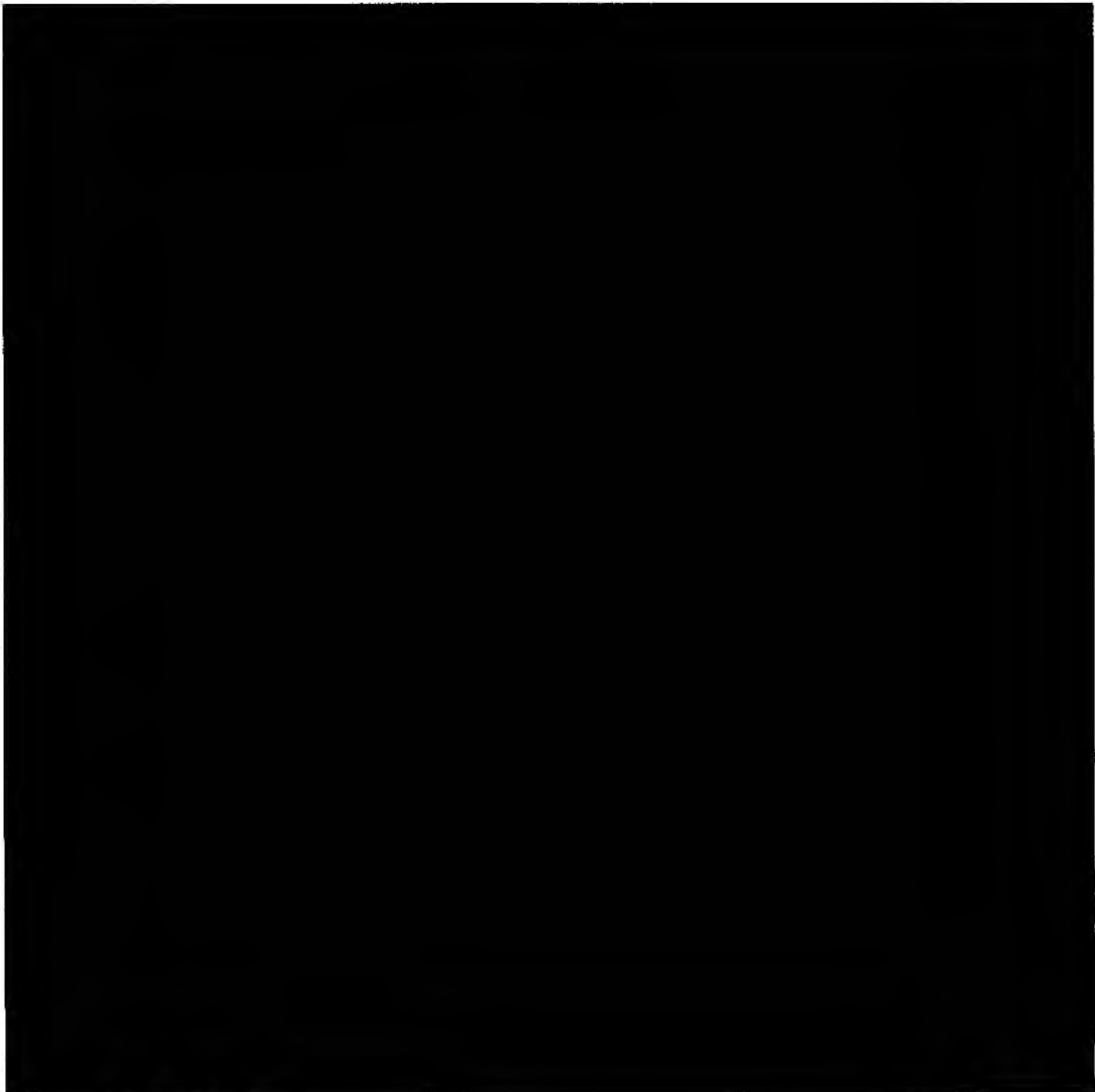
Fig 12

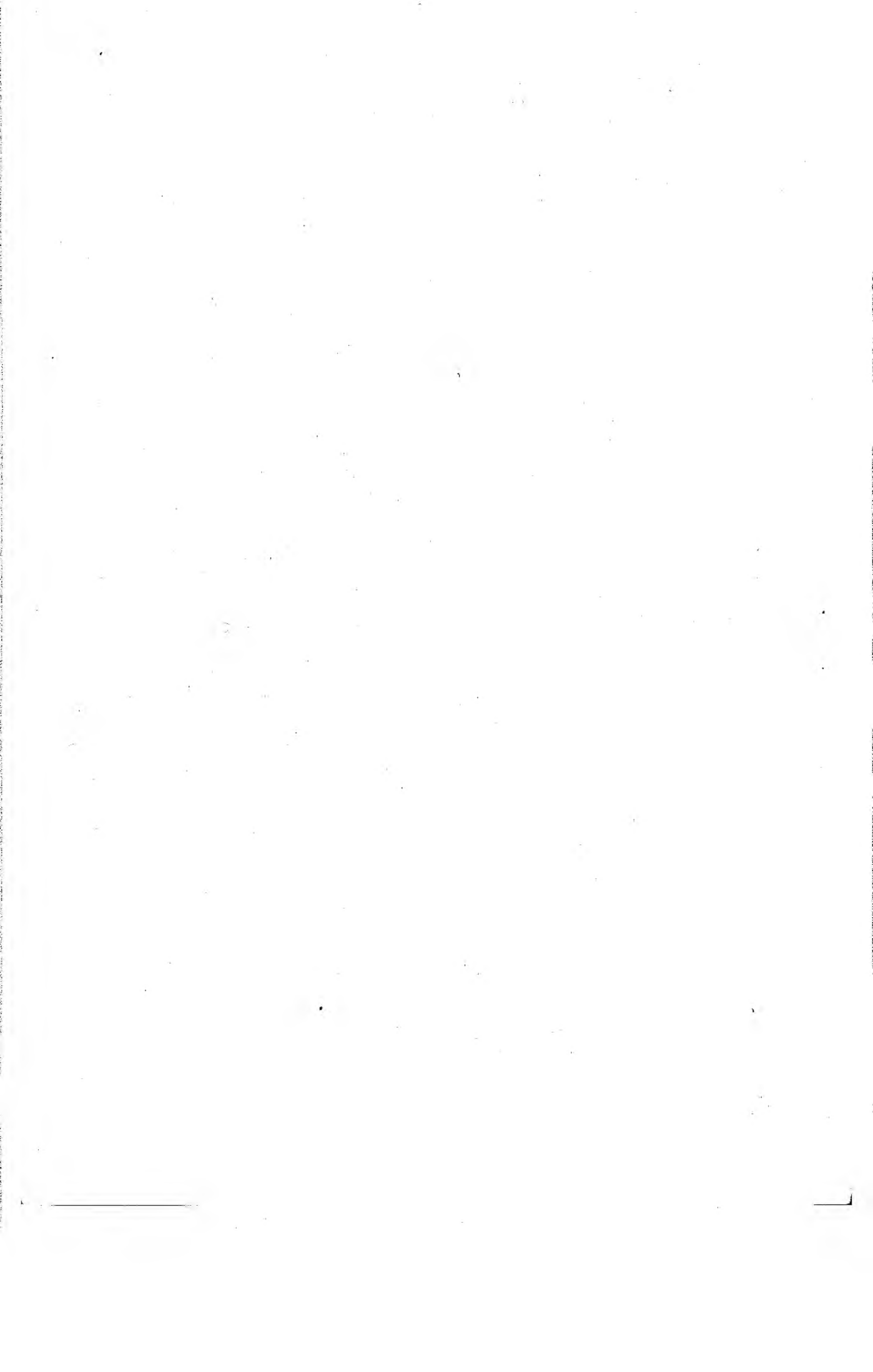
Jan 91 (Amdt 2)

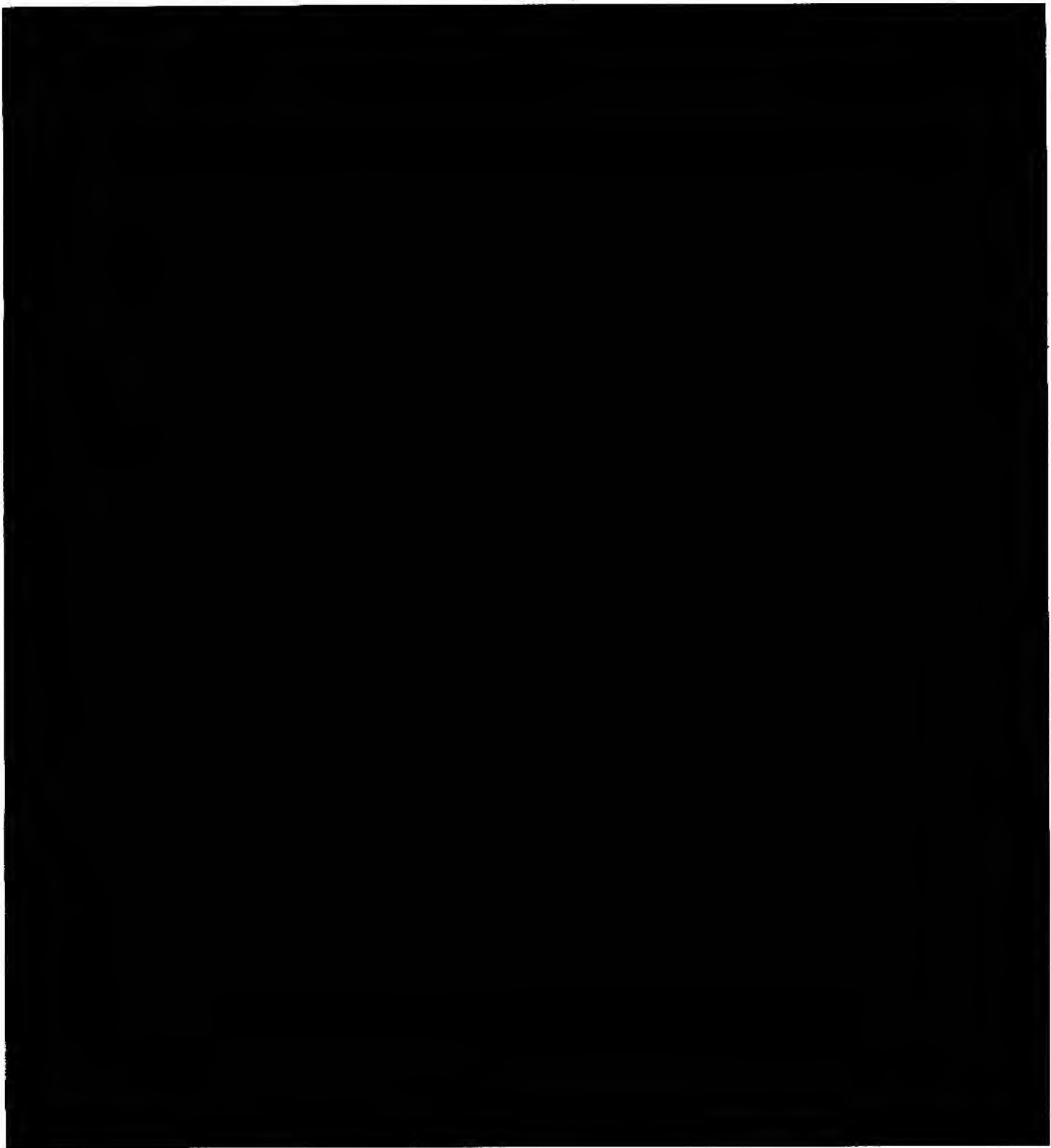


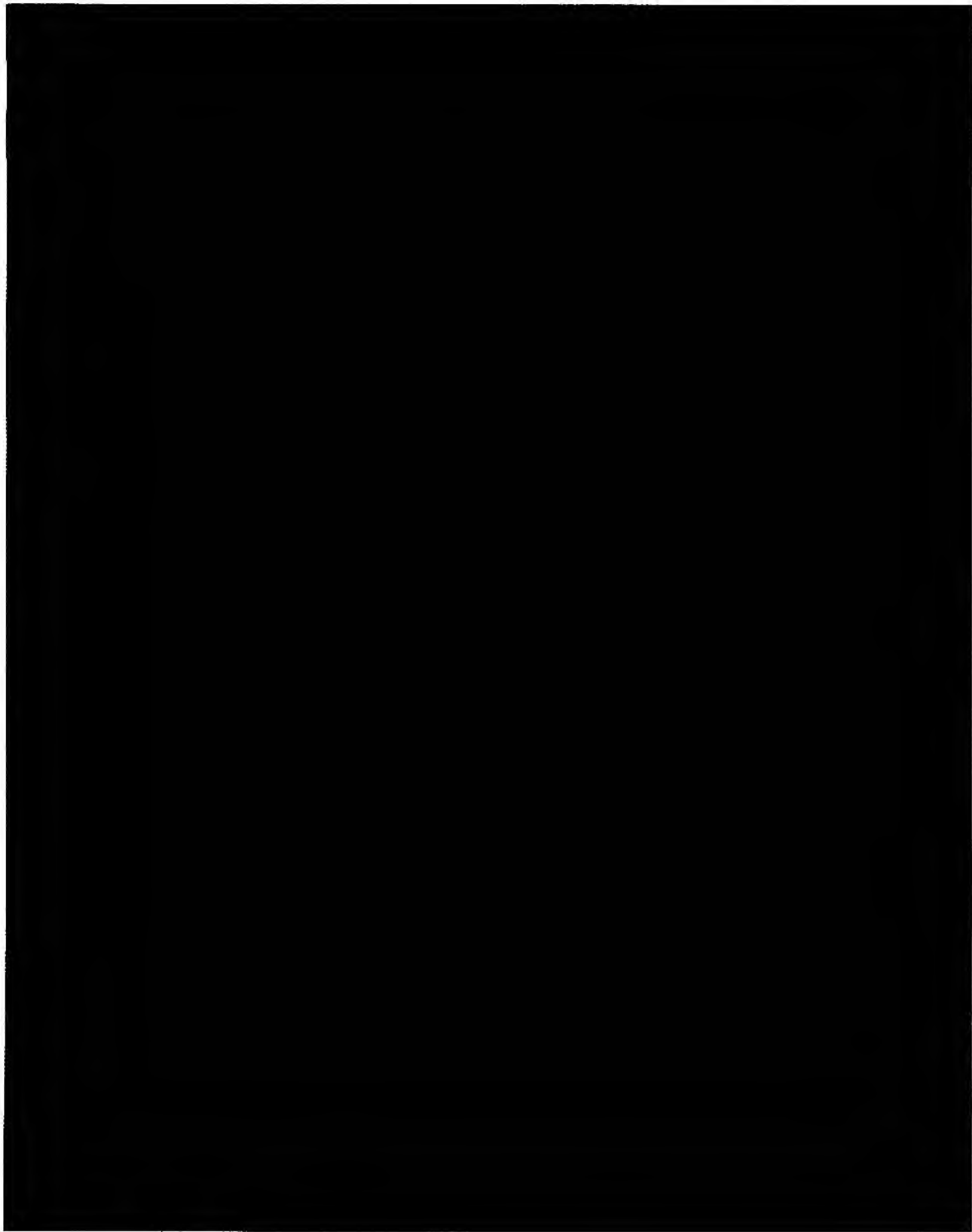


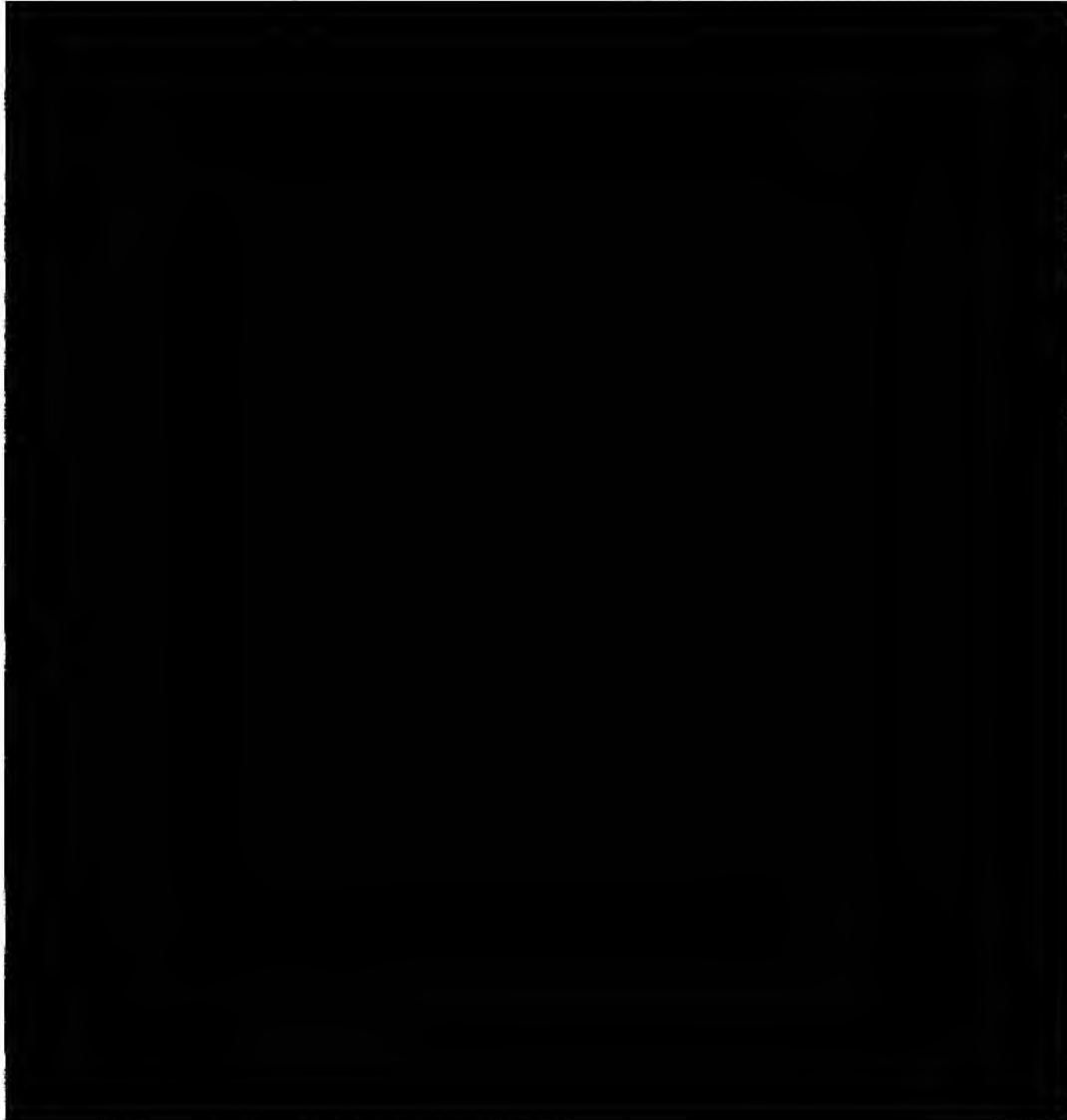


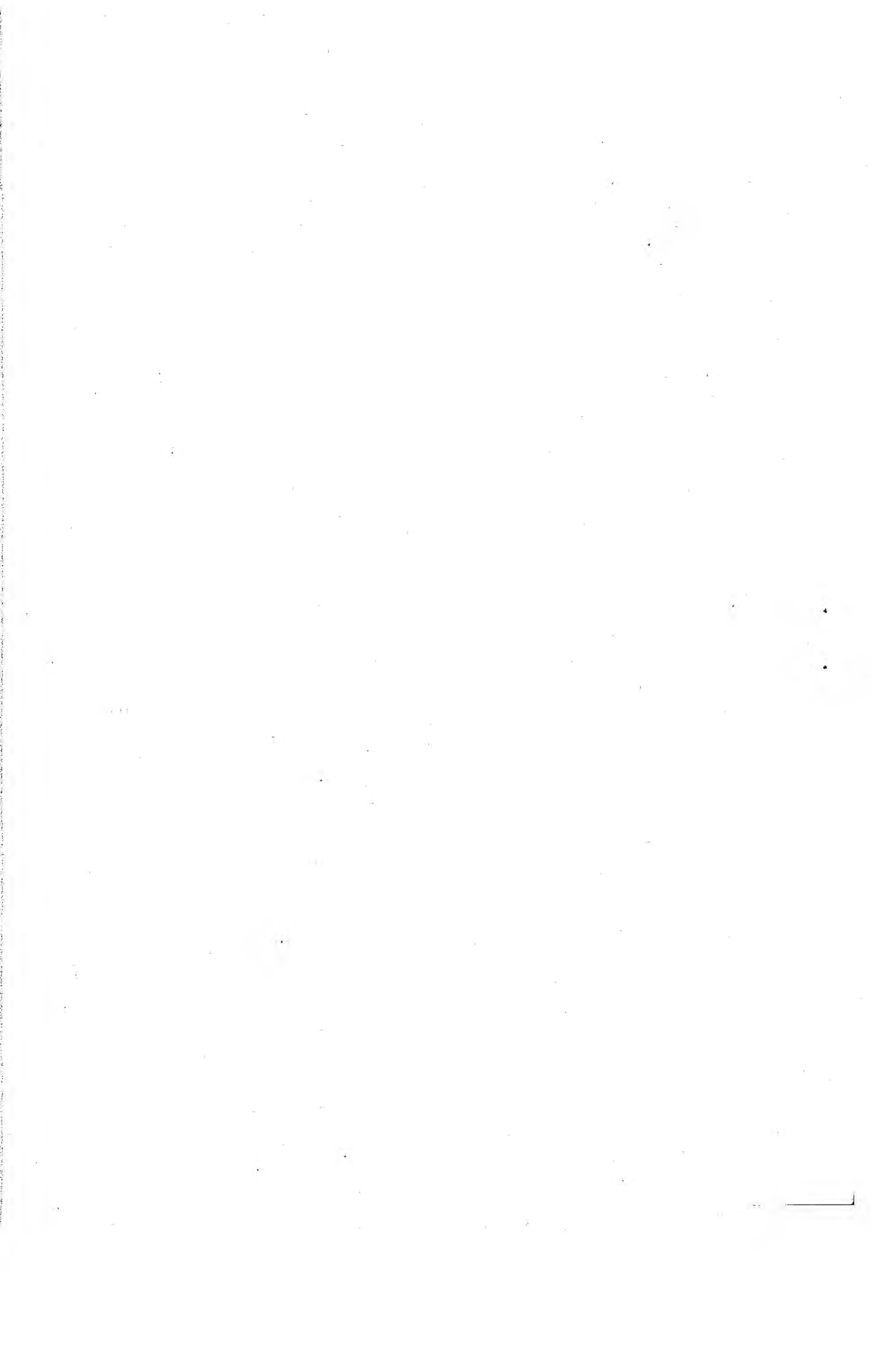












[REDACTED]

[REDACTED]

[REDACTED]

[REDACTED]

[REDACTED]

[REDACTED] y

[REDACTED]

[REDACTED]

[REDACTED]

[REDACTED]

[REDACTED]

[REDACTED]

[REDACTED]

[REDACTED]

[REDACTED]

[REDACTED]

[REDACTED]

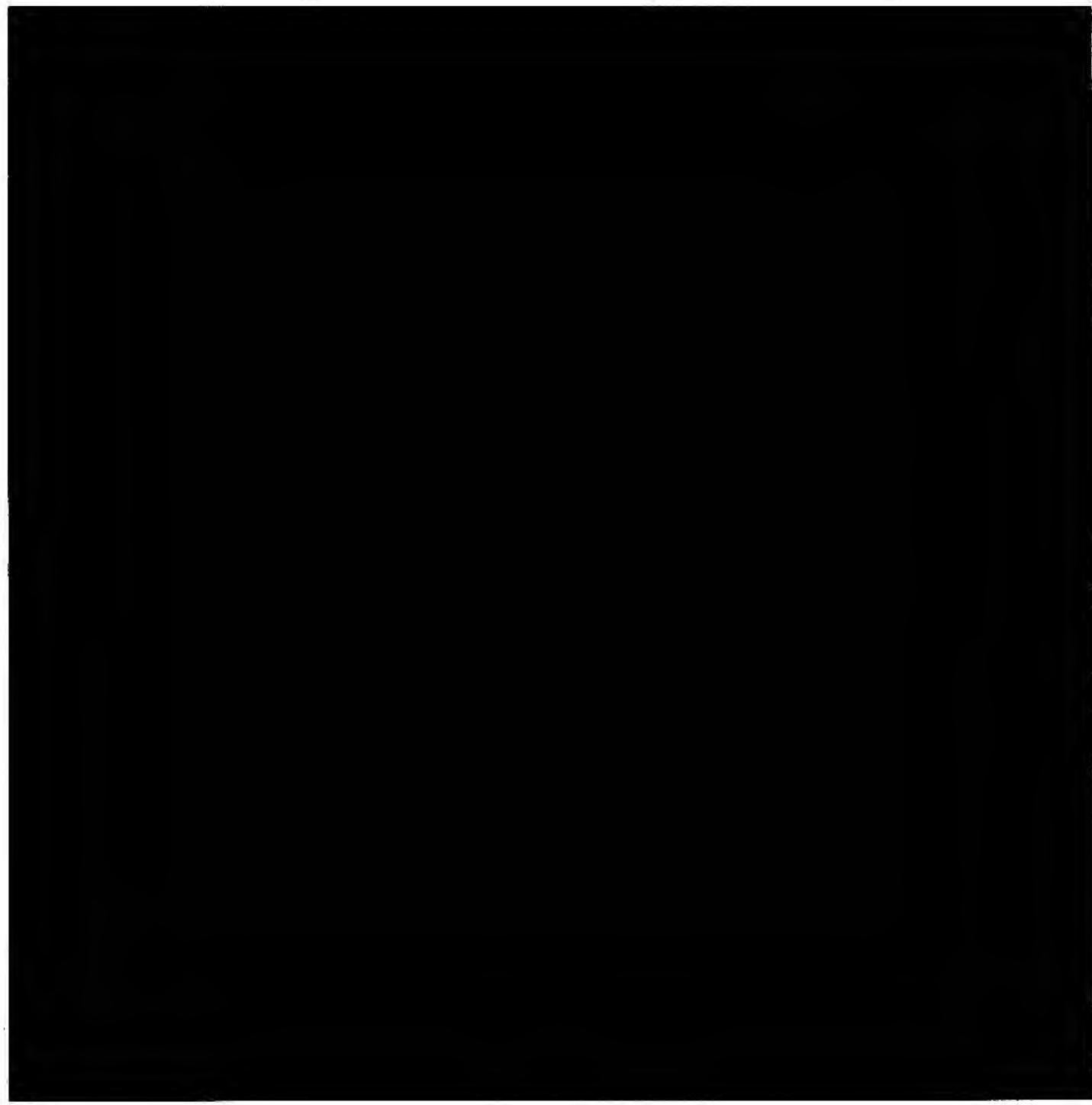
[REDACTED]

[REDACTED]

[REDACTED]

[REDACTED]







Chapter 15

CHASSIS

TECHNICAL DESCRIPTION

INTRODUCTION

1 This Chapter gives the Technical Description for chassis fitted to Land Rover 90, 110 and 127 vehicles.

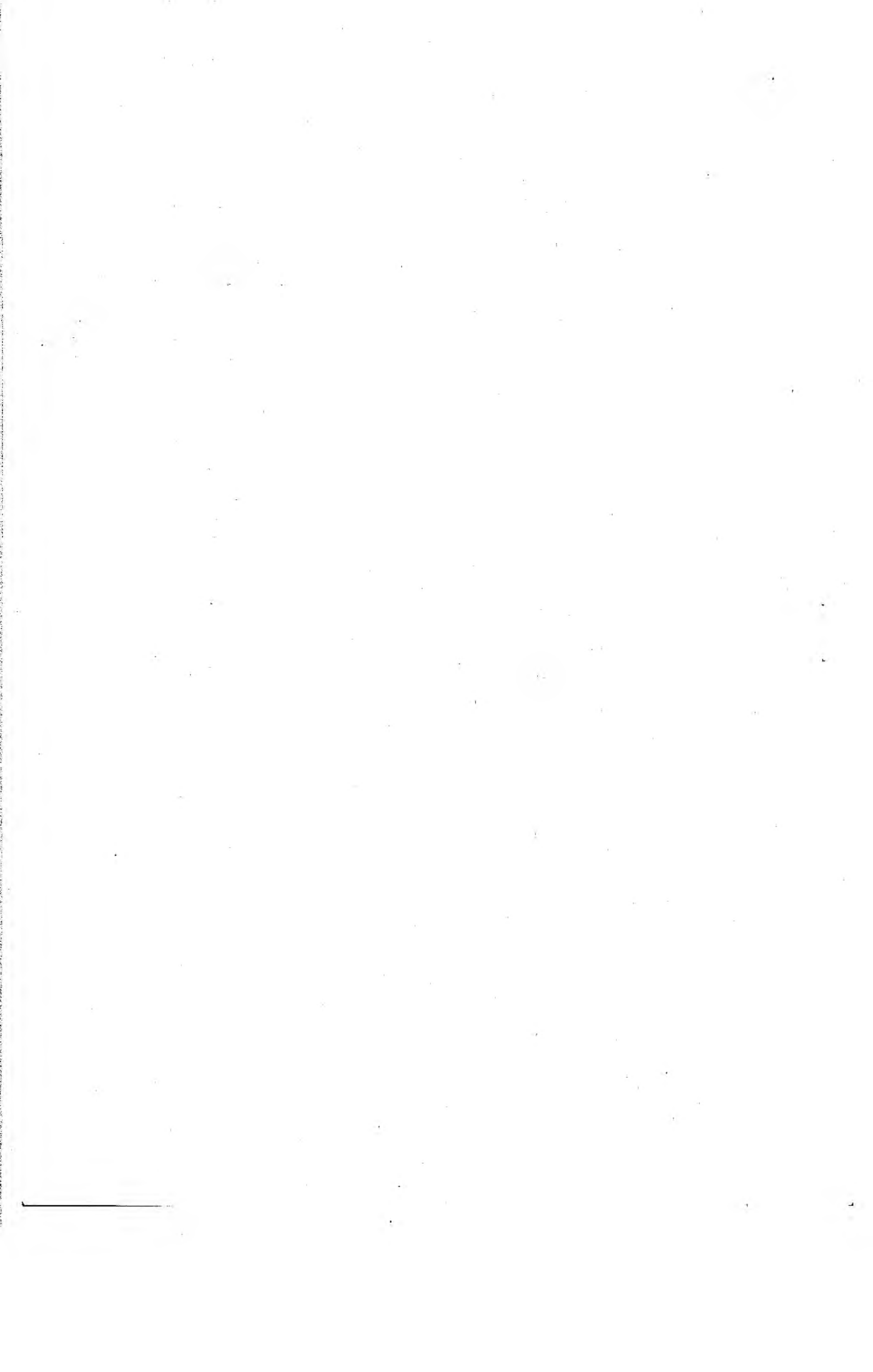
2 The Chapter has been Sub-chaptered as follows to accommodate the chassis fitted to Land Rover 90 and 110 vehicles, and the chassis fitted to Land Rover 127 vehicles.

Chapter 15-1 CHASSIS 90 AND 110 VEHICLES

Chapter 15-2 CHASSIS 127 VEHICLES

General

3 The information given is applicable to both left and right hand drive vehicles.



Chapter 15-1
CHASSIS 90 and 110 vehicles

CONTENTS

Frame	Para		Page
	1	Introduction	
	2	Description	
	5	Corrosion protection	
Fig			Page
	1	Land Rover 110 chassis	1

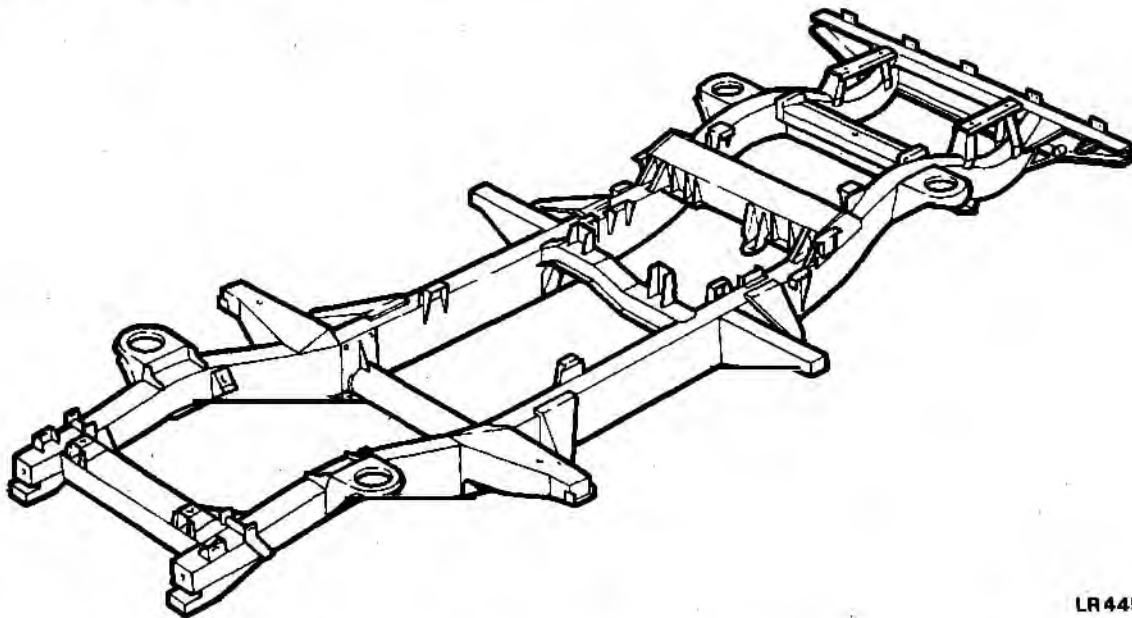
INTRODUCTION

1 This Chapter gives a Technical Description of the chassis as fitted to Land Rover 90 and 110 vehicles.

Description

2 The chassis frame is of 'ladder' type construction, made up from two parallel side members, manufactured from 2 mm (14 gauge) steel sub-assemblies welded into box sections. To ensure accuracy, welding is carried out by computer controlled robotic welders.

3 The 'ladder' frame construction resists twisting (torsional) and bending (flexing) stresses encountered in all types of conditions on and off road. The longitudinal chassis members are constructed from U-section assemblies, welded top and bottom into a box section. The box section is internally strengthened by tubes or scroll plates to avoid compression when ancillary equipment is bolted in place.



LR4459M

Fig 1 Land Rover 110 chassis

4 The Land Rover 90 is fitted with four cross members and the Land Rover 110 having six. The cross member situated beneath the transmission is removeable for ease of maintenance or removal of the gear or transfer boxes. The remaining cross members are welded in position.

Corrosion protection

5 To protect the chassis against corrosion, after assembly it is degreased, cleaned and dried, then shot blasted and immersed in grey water based primer and stove baked at 115°C. After priming the chassis is dip coated in black enamel and stove baked to 160°C. Holes are positioned along the chassis to allow full paint penetration over the inner surfaces. For extra safety and long life the rear cross member is wax injected to thoroughly exclude moisture.

Chapter 15-2

CHASSIS

CONTENTS

Frame	Para		Page
	1	Introduction	
	2	Description	
	3	Frame alignment	
	5	Corrosion protection	
Fig			
	1	Land Rover 127 chassis	1

INTRODUCTION

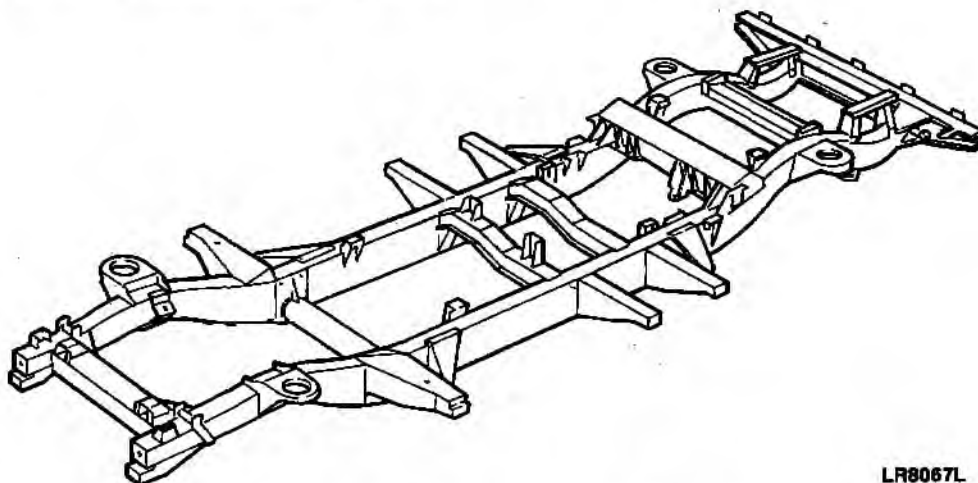
1 This Chapter gives a Technical Description of the chassis as fitted to the Land Rover 127 vehicle.

Description

2 The chassis frame is of 'ladder' type construction made up from two parallel side members, manufactured from 2 mm (14 gauge) steel sub-assemblies welded into box sections. To ensure accuracy, welding is carried out by computer controlled robotic welders.

Frame alignment

3 The 'ladder' frame construction resists twisting (torsional) and bending (flexing) stresses encountered in all types of conditions on and off road. The longitudinal chassis members are constructed from U-section assemblies, welded top and bottom into a box section. The box section is internally strengthened by tubes or scroll plates to avoid compression when ancillary equipment is bolted in place.



LR8067L

Fig 1 Land Rover 127 Chassis

4 The Land Rover 127 is fitted with seven cross members. The cross member situated beneath the transmission housing is removeable for ease of maintenance or removal of the gear or transfer boxes. The remaining cross members are welded in position.

Corrosion protection

5 To protect the chassis against corrosion, after assembly it is degreased cleaned and dried, then shot blasted and immersed in grey water based primer and stove baked at 151°C. After priming the chassis is dip coated in black enamel and stove baked to 160°C. Holes are positioned along the chassis to allow full paint penetration over the inner surfaces. For extra safety and long life the rear cross member is wax injected to thoroughly exclude moisture.

Chapter 17

ELECTRIC WINCH 127 VEHICLES

TECHNICAL DESCRIPTION

CONTENTS

Frame	Para		Page
	1	Introduction	
	2	General	
	5	Motor	
	6	Clutch	
	7	Gearbox	
	8	Drum and wire rope assembly	
	9	Fairlead rope guide	
	10	Remote control	
	11	Brake assembly	
	Fig		
	1	Electric winch arrangement	2

INTRODUCTION

1 This Chapter details the technical description for the electric winch fitted to Land Rover 127 vehicles.

GENERAL

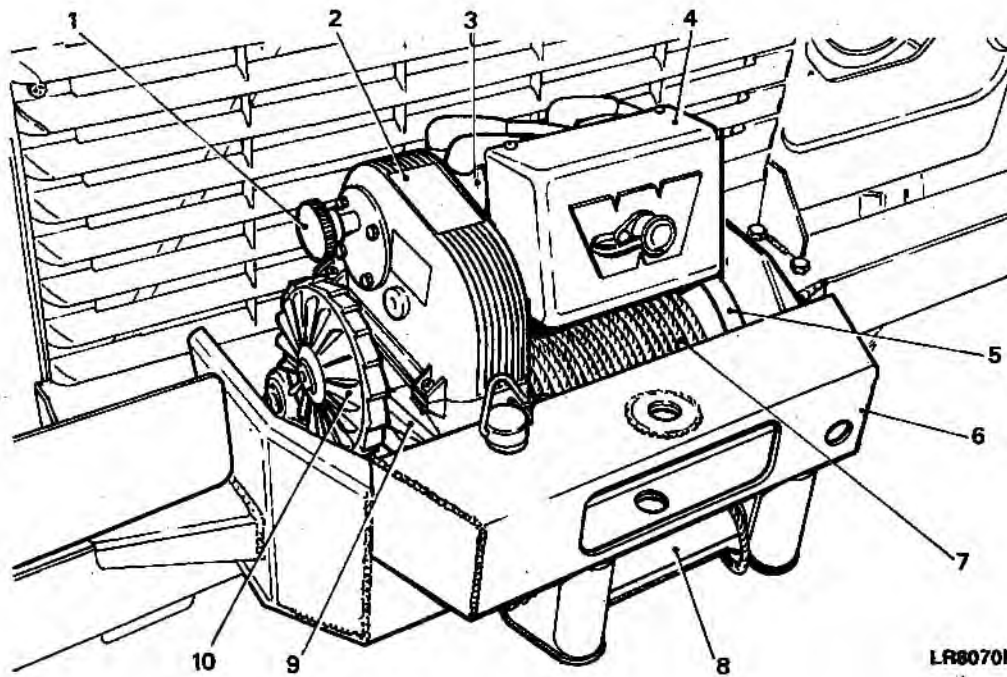
2 The winch assembly, mounted on a special cradle (Fig 1 (6)) attached to the front vehicle bumper is powered by an electric motor (3). The motor is engaged by a manual clutch control (1), housed in the upper gear case (2).

3 Drive is transmitted via a series of gears to the drum (5) which accommodates the wire rope assembly (7). A fairlead rope guide bracket (8) mounted on the front of the cradle permits unrestricted wire rope movement during winch operations.

4 A remote control switch unit and wander lead when engaged with the solenoid control housing (4) operates the electric motor. A brake assembly (10) housed externally on the lower gear case (9) automatically activates against a load when the drum is static.

Motor

5 The electric motor is of a 12 volt DC type mounted externally on the upper gear case. It has three terminals provided for connection into the solenoid housing plus a fourth which accommodates the negative lead. The drive shaft locates into the clutch pinion via a bearing.



LR8070L

- | | |
|----------------------------|---------------------------|
| 1 Clutch control | 6 Mounting cradle |
| 2 Upper gear case | 7 Wire rope assembly |
| 3 Electric motor | 8 Wire rope guide bracket |
| 4 Solenoid control housing | 9 Lower gear case |
| 5 Drum | 10 Brake assembly |

Fig 1 Electric winch arrangement

Clutch

6 The manual clutch assembly is mounted in the upper gear case and is operated by an external push/pull control knob. A motor pinion positioned at the end of the shifter assembly, when engaged allows drive from the motor output shaft to be transmitted to the gears in the gearbox assembly.

Gearbox

7 The gearbox casing consists of an upper and lower housing. The upper housing contains the motor pinion which when actuated by the clutch engages with a gear cluster. Drive is then transmitted to intermediate and main gears contained in the lower housing. The main gear also has a ring of internal teeth which mesh with an external gear on the drum shaft.

Drum and wire rope assembly

8 The drum and gear shaft which pass through a seal and thrust washer assembly before engagement with the main gear is held to the lower housing by an end support, bolted to the mounting cradle. The wire rope and hook assembly which is distributed and retrieved from the underside, is tethered by a 'U' bolt clamp restricted to the end of the drum.

Fairlead rope guide

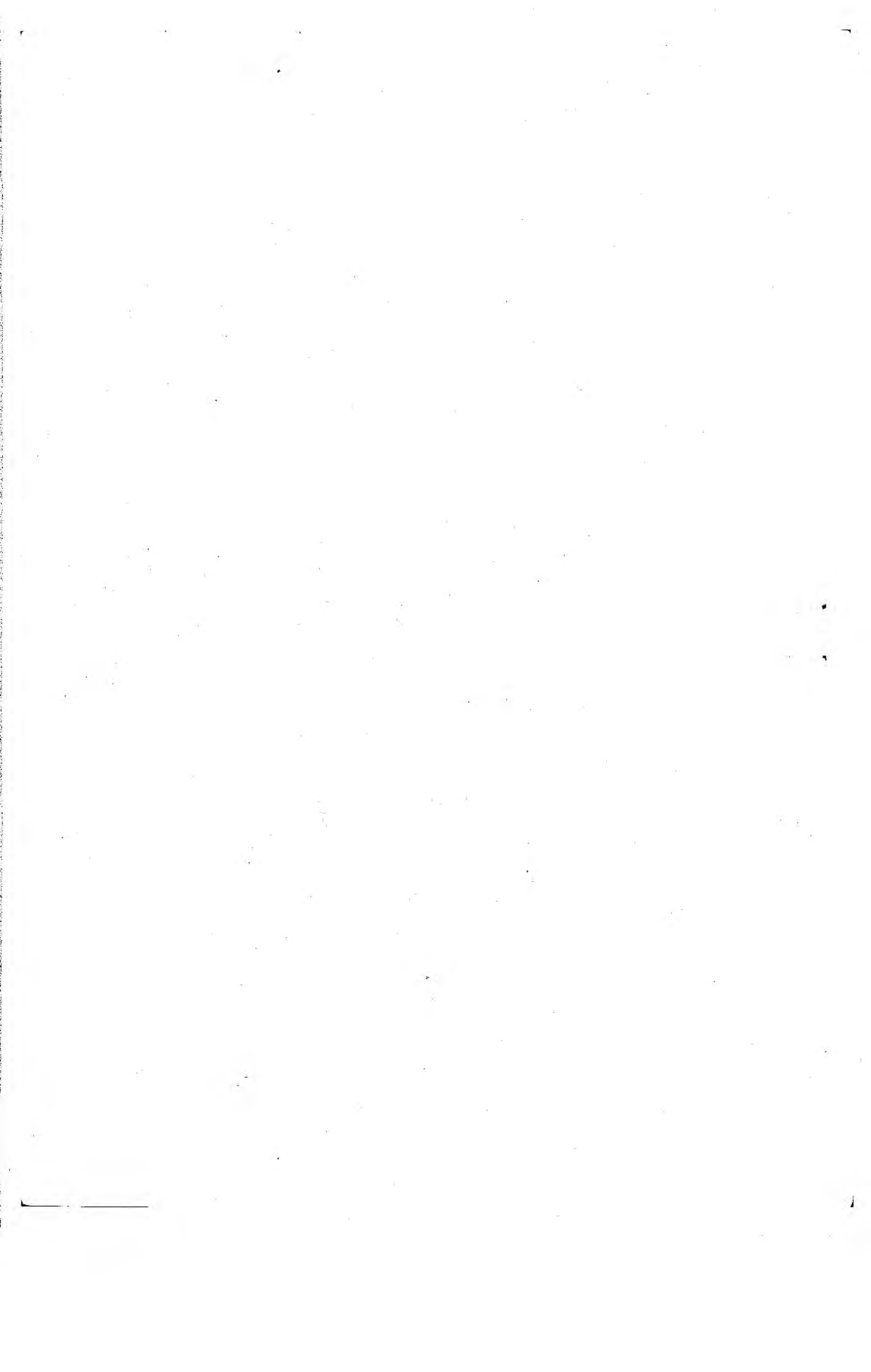
9 The fairlead rope guide is bolted externally to the base of the mounting cradle and consists of two horizontal and vertical rollers which permit unrestricted movement and guard against damage to the wire rope.

Remote control

10 The remote control consists of a hand held switch unit connected by insulated cable which is plugged into a socket terminal externally mounted on the front of the solenoid control housing. The spring loaded toggle switch on the hand held unit activates the electric motor allowing the winch to be powered either 'in' or 'out'. A third switch position provides a neutral or 'off' mode.

Brake assembly

11 The brake assembly consists of a two friction linings, spring applied and housed either side of a ratchet and between an inner and outer disc. The assembly is accommodated on a central pinion and cam which in turn is located into the intermediate gear, contained in the lower housing. A pawl and spring assembly is mounted externally to the side of the brake assembly and locates into the ratchet teeth. When the winch is under load and the remote control switch is returned to a neutral position, the brake automatically activates.



Chapter 18

HEATING AND VENTILATION

TECHNICAL DESCRIPTION

Introduction

1 This Chapter details the technical description for the heating and ventilation system fitted Land Rover 2.5 litre diesel winterised 90 and 110 vehicles.

2 The Chapter has been Sub-chaptered as follows to accommodate any future variants.

Chapter 18.1 WINTERISED HEATING AND VENTILATION SYSTEM

3 The information is applicable to both right and left hand drive vehicles.

Chapter 18-1

WINTERISED HEATING AND VENTILATION SYSTEM

TECHNICAL DESCRIPTION

CONTENTS

Frame	Para		Page
	1	Introduction	
	2	General	
	3	Interior water heater circuit	
	4	Description	
	4	Operation	
	6	Interior air ducting	
	6	Windscreen and cab	
	7	Side screen demisters	
	Fig		
	1	Water circuit	3/4
	2	Side screen demisters	5

INTRODUCTION

1 This Chapter details the technical description for the heating and ventilation system fitted to Land Rover 2.5 litre diesel winterised 90 and 110 vehicles.

GENERAL

2 Land Rover winterised 90 and 110 vehicles have been specifically designed to operate in extreme sub-zero climatic conditions. In order to meet the required specification a 'Webasto' DBW 46 water heater has been incorporated as an aid to engine cold start. The vehicle internal heater feed hose is connected into the water pre heater circuit, but only receives its hot water from the cooling system when propelled by the engine water pump after ignition. The water heater operates independently of the engine and is installed to raise coolant temperature prior to starting.

Interior water heater circuit (Fig 1)

Description

3 The water heater circuit consists of a series of hoses and copper tubing connected to the standard heater matrix and five interior mounted radiators. One radiator is mounted under the passenger seat in the left hand side of the vehicle battery box and a further two banks of two are mounted adjacent to each other in the rear of the vehicle. An air bleed valve is fitted to each of the rear radiator banks and an on/off water flow valve is mounted at the front of the vehicle rear bulkhead. All pipes exposed to atmosphere are fully insulated.

Operation

4 Operation of the water heater automatically terminates when the engine ignites. Water is therefore static in the water pre heater system, allowing engine coolant at temperature to be propelled by the engine water pump through to the vehicle heater matrix where hot air is supplied to the interior assisted by the heater fan.

5 A tee connection fitted to the vehicle heater feed line allows hot water to be fed under the engine compartment bulkhead and into the battery box radiator. Hot water is then supplied from the battery box radiator through the rear bulkhead to the left hand bank of radiators. The water is then returned back through the left hand bank to a feed line mounted across the rear of the rear bulkhead where an on/off water flow valve, accessible from the driver's compartment is centrally mounted. The valve provides the operator with an option of preventing flow within the internal radiator system, therefore restricting circulation to the heater matrix. When the flow valve is open, water continues through the right hand bank of radiators, returning under the engine compartment bulkhead to the engine, via a tee connection fitted into the vehicle heater to engine return line.

Key to fig 1

1	Water heater	8	LH radiator bleed valve
2	Vehicle heater to engine return	9	LH rear radiator bank
3	Diesel fuel supply	10	Battery box radiator
4	Engine to vehicle heater feed	11	Vehicle heater matrix
5	On/off water flow valve	12	Radiator/oil cooler
6	RH rear radiator bank	13	Expansion hose
7	RH radiator bleed valve		

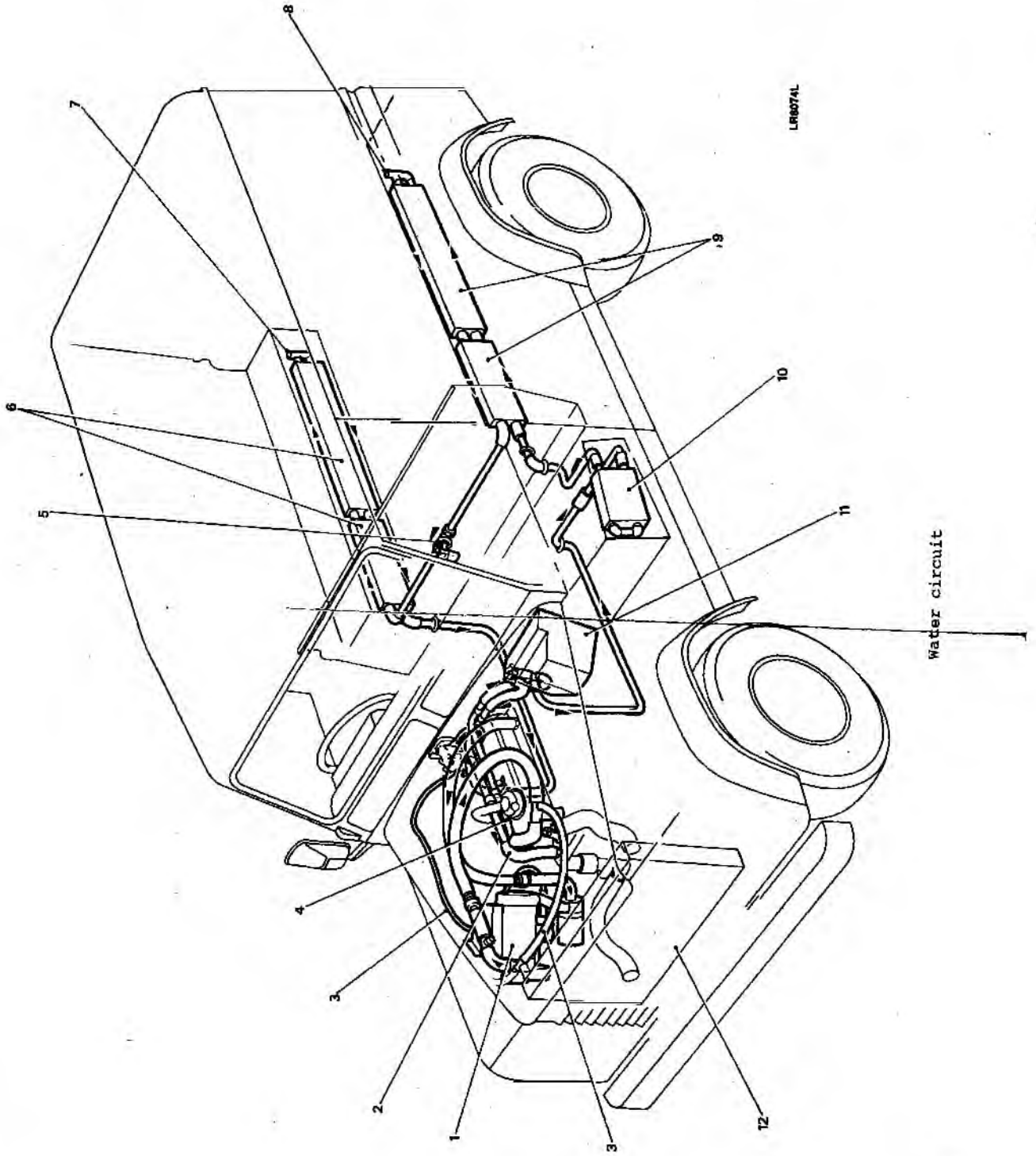


Fig 1
Jan 91 (Amdt 2)

Water circuit



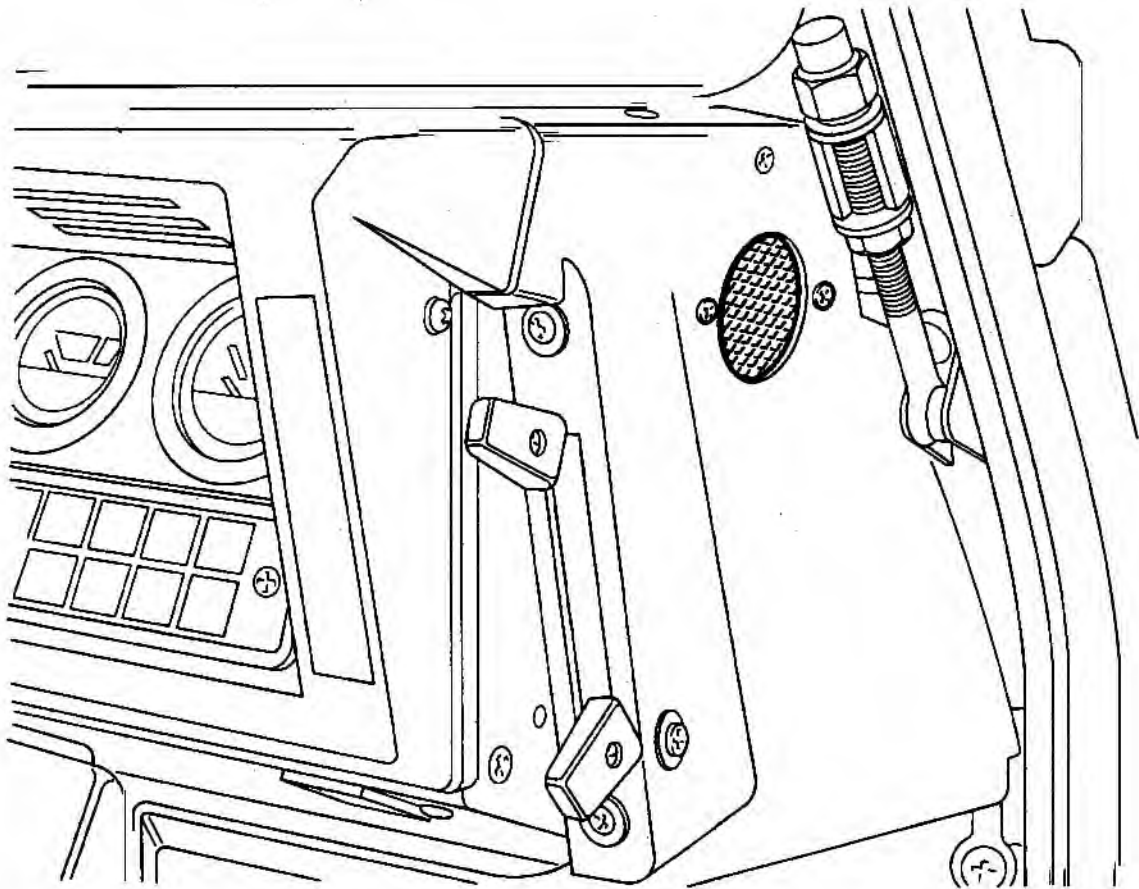
Interior air ducting

Windscreen and cab

6 For details of the interior air ducting to front windscreen and cab refer to Cat 302 Chap 16-1.

Side screen demisters (Fig 2)

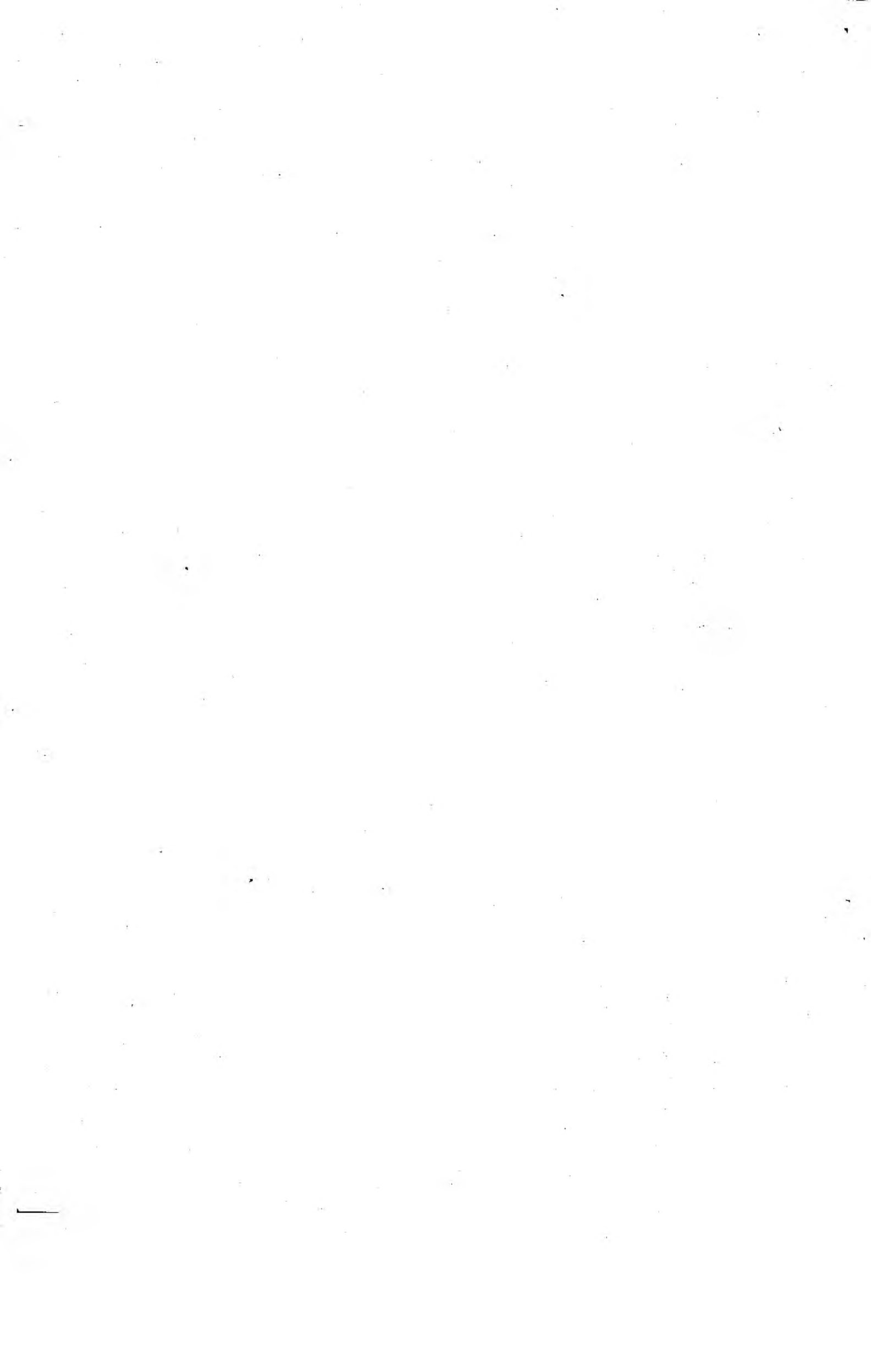
7 A duct and vent is connected each side of the vehicle into the standard windscreen ducting system supplying air to the front side screens. Operation of air supply is via the standard windscreen/footwell heater controls.



LR8075L

Fig 2 Side screen demisters







B VEHICLE CORROSION PREVENTION

This publication contains information covering the requirements of
Category 2 at information level 1 and category 5 at
information levels 2, 3 and 4

**Sponsored for use in the
UNITED KINGDOM MINISTRY OF DEFENCE
AND ARMED FORCES
by**

DE & S LAND SYSTEMS SAFETY AND ENGINEERING

**Publication Authority:
DES SE LAND-EP-PC1**

CONDITIONS OF RELEASE

~~This information is released by the UK Government for Defence purposes only.~~

~~This information must be afforded the same degree of protection as that afforded to information of an equivalent classification originated by the recipient Government or as required by the recipient Government's National Security regulations.~~

~~This information may be disclosed only within the Defence Department of the recipient Government, except as otherwise authorized by the Ministry of Defence (Army).~~

~~This information may be subject to privately owned rights.~~

~~THIS DOCUMENT IS THE PROPERTY OF HER BRITANNIC MAJESTY'S GOVERNMENT, and is issued for the information of such persons only as need to know its contents in the course of their official duties. Any person finding this document should hand it in to a British forces unit or to a police station for its safe return to the Ministry of Defence, (DDef Cy), Main Building, Whitehall London, SW1A 2HB, with particulars of how and where found. THE UNAUTHORIZED RETENTION OR DESTRUCTION OF THIS DOCUMENT IS AN OFFENCE UNDER THE OFFICIAL SECRETS ACTS OF 1911-1989. (When released to persons outside Government service, this document is issued on a personal basis. The recipient to whom it is entrusted in confidence, within the provisions of the Official Secrets Acts 1911-1989, is personally responsible for its safe custody and for seeing that its contents are disclosed only to authorized persons.)~~

© CROWN COPYRIGHT RESERVED

AMENDMENT RECORD

Amdt No.	Incorporated By (Signature)	Date
1		
2		
3		
4		
5		
6		
7		
8		
9		
10		
11		
12		
13		
14		
15		
16		
17		
18		
19		
20		
21		
22		
23		
24		
25		
26		
27		
28		
29		
30		
31		

Amdt No.	Incorporated By (Signature)	Date
32		
33		
34		
35		
36		
37		
38		
39		
40		
41		
42		
43		
44		
45		
46		
47		
48		
49		
50		
51		
52		
53		
54		
55		
56		
57		
58		
59		
60		
61		
62		

CONTENTS

PRELIMINARY MATERIAL

	Page
Front cover (title page)	(i)
CONDITIONS OF RELEASE	(ii)
AMENDMENT RECORD	(iii)/(iv)
CONTENTS (this list)	(v)
PREFACE	(vi)
Introduction	(vi)
Related and associated publications	(vi)
Related publications	(vi)
Associated publications	(vii)/(viii)
COMMENT(S) ON AESP*	Final leaf

Para

- 1 Introduction
- 2 Applicability
 - Standard commercial cars saloon, cars utility, coaches and vans
- 3 Wax injection and underbody protection
- 4 Manufacturer's bodywork anti-perforation/ corrosion warranties
 - Large goods vehicles, coaches and specialist vehicles
- 5 Vehicle chassis and sub-chassis
- 6 Coach bodies
- 7 Vehicle cabs
- 8 Specialist vehicle bodies
- 9 Lifting equipment superstructures, booms, masts and jibs
- Trailers
- 10 Trailer chassis
- 11 Trailer bodies
- 12 Variations in examination and corrosion prevention procedures
 - Vehicle corrosion prevention procedures application of PX 28 (WARNINGS) (CAUTION)
- 13 Preparation
- 14 Spraying equipment
- 15 Vehicle cabs
- 16 Specialist vehicles, trailers and bodies

Fig

Page

- 1 Examples of enclosed box sections to be found at the front and sides of a vehicle cab/body **Error!**
Bookmark not defined.
- 2 Examples of box sections to be found on a cab door 6
- 3 Examples of box sections to be found at the rear of a cab 6
- 4 Examples of box sections to be found on the underside/floor of a vehicle cab 7

Annex A – Vehicle bodywork warranty examination form

Fig

- 5 Example of light/medium vehicle body A-1

Table

- 1 Record of bodywork defects A-2

PREFACE

Sponsor: DG S and E
File Ref: SE Land WIP430\11\
Pubs\Contract\AESP\
310-201

Publication Authority: DES SE Land-EP-PC1

INTRODUCTION

1 Any comments by service users on this publication should be forwarded through the channels prescribed in Army Equipment Support Publication (AESP) 0100-P-011-013. An AESP Form 10 is provided at the end of this publication; it should be photocopied and used for forwarding comments on this AESP.

2 AESPs are issued under UK MOD authority and where AESPs specify action is to be taken, the AESP will of itself be sufficient authority for such action and also for the demanding of the necessary stores, subject to the provisions of Para 3 below.

3 The subject matter of this publication may be affected by Defence Instructions and Notices (DINs), Standard Operating Procedures (SOPs) or by local regulations. When any such instruction, Order or Regulation contradicts any portion of this publication it is to be taken as the overriding authority.

RELATED AND ASSOCIATED PUBLICATIONS

Related publications

4 The Octad for the subject equipment consists of the publications shown opposite. All references are prefixed with the first eight digits of this publication. The availability of the publications can be checked by reference to the relevant Group Index (see AESP 0100-A-001-013).

Category/Sub-category			Information Level			
			1 User/Operator	2 Unit Maintenance	3 Field Maintenance	4 Base Maintenance
1	0	Purpose and Planning Information	*	*	*	*
	1	Equipment Support Policy Directive	*	*	*	*
2	0	Operating Information	*	*	*	*
	1	Aide Memoiré	*	*	*	*
	2	Training Aids	*	*	*	*
3		Technical Description	*	*	*	*
4	1	Installation Instructions	*	*	*	*
	2	Preparation for Special Environments	*	*	*	*
5	1	Failure Diagnosis	*	*	*	*
	2	Maintenance Instructions	*	*	*	*
	3	Inspection Standards	*	*	*	*
	4	Calibration Procedures	*	*	*	*
6		Maintenance Schedules	*	*	*	*
7	1	Illustrated Parts Catalogues	*	*	*	*
	2	Commercial Parts Lists	*	*	*	*
	3	Complete Equipment Schedule, Production	*	*	*	*
	4	Complete Equipment Schedule, Service Edition (Simple Equipment)	*	*	*	*
	5	Complete Equipment Schedule, Service Edition (Complex Equipment)	*	*	*	*
8	1	Modification Instructions	*	*	*	*
	2	General Instructions, Special Technical Instructions and Servicing Instructions	*	*	*	*
	3	Service Engineered Modification Instructions (RAF only)	*	*	*	*

*Category/sub-category not published.

Associated publications

5	Reference	Title
	JSP 375	MOD Health and Safety Handbook
	JSP 437	Personal Protective Equipment Catalogue
	JSP 515	Hazardous Stores Information System
	JSP 800	Defence Movements and Transportation Regulations Vol 5
	EMER T & M A 028 Chap 150	General Principles of Quality Assessment of Vehicles
	AESP 0200-A-100-013	Mandatory Equipment Inspection (MEI)
	Vehicle Inspectorate	Heavy Goods Vehicle Inspection Manual
	Vehicle Inspectorate	Public Service Vehicle Inspection Manual
	Vehicle Inspectorate	Car and Light Commercial Vehicle Testing Manual
	AESP Octad	For specific vehicle as necessary

WARNINGS AND CAUTIONS

6 WARNINGS

VEHICLE CORROSION PREVENTION PROCEDURES APPLICATION OF PX 28

- (1) **HEALTH HAZARD. PERSONNEL SPRAYING PX 28 ARE TO WEAR THE APPROPRIATE PROTECTIVE CLOTHING AND RESPIRATOR/BREATHING EQUIPMENT IN ACCORDANCE WITH MANUFACTURERS SAFETY DATA SHEETS AND/OR JSP 437.**
- (2) **HEALTH HAZARD. PERSONNEL ARE TO BE CONVERSANT WITH THE HEALTH HAZARDS AND SAFETY PRECAUTIONS CONTAINED ON THE SAFETY DATA SHEET PRIOR TO SPRAYING PX 28.**
- (3) **HEALTH HAZARD. APPLICATION OF PX 28 IS TO BE CARRIED OUT IN VEHICLE SPRAY BAYS/BOOTHES WITH BUILT IN EXTRACTION FACILITIES OR IN DESIGNATED AREAS AS APPROVED BY LOCAL HEALTH AND SAFETY MANAGEMENT, IN ACCORDANCE WITH REGULATIONS LAID DOWN UNDER THE H AND SW ACT 1974 AND LOCAL FIRE ORDERS.**
- (4) **FIRE HAZARD. AFTER SPRAYING PX 28 IN/ONTO A VEHICLE THE VEHICLE IS NOT TO BE USED/DRIVEN FOR AT LEAST FOUR HOURS. IDEALLY THE VEHICLE SHOULD BE LEFT INSIDE THE SPRAY BAY OVERNIGHT TO ALLOW THE PX 28 TO DRY OFF.**

7 CAUTIONS

- (1) **MASKING. Where necessary and before spraying, mask off any brake components, electrical wiring, plastic pipes/hoses and mechanical linkages etc.**

INTRODUCTION

1 This AESP details the corrosion prevention procedures to be carried out on green fleet B vehicles used in the Services as called for routinely in individual vehicle AESP Category 6 Maintenance Schedules or after any rectification work as necessary. Unit personnel carrying out either routine maintenance or rectification work are to ensure that any corrosion found is removed, using the appropriate equipment and complying with relevant safety precautions as necessary, before repainting or treating of affected areas. This AESP also gives details on the application of PX 28 to vehicles as a corrosion prevention measure. PX 28 is to be applied to vehicle types listed in this AESP by a specialist Painter and Finisher (P&F) MOD civilian or contract tradesmen in an authorised specialist vehicle spray bay/booth.

APPLICABILITY

2 This AESP applies to all green fleet B vehicles. Green fleet vehicles are those maintained in-house. Dual role vehicles, e.g. Ambulance Role Coaches, EOD vans etc, will remain an in-service responsibility. As a guideline, any vehicle with letters NB as part of the Equipment Asset Code shall be subject to in-service/contract corrosion prevention. In instances where cabs or bodies are manufactured from non-metallic materials, (fibre glass, plastic etc) whilst corrosion is not likely to effect these components, they should still be examined where they contribute to the overall strength of the vehicle. All metallic supporting framework, box sections and attachments should be treated as necessary.

STANDARD COMMERCIAL CARS SALOON, CARS UTILITY, COACHES AND VANS

Wax injection and underbody protection.

3 Modern vehicles have wax injection of hollow body sections and underbody protection applied during manufacture. The re-application of wax injection or underbody protection is not necessary for variants of cars saloon, cars utility, coaches small, ambulances and vans, unless specifically called for in the vehicle's AESP Category 6.

Manufacturer's bodywork anti-perforation/ corrosion warranties

4 Most light and medium vehicles are covered by a manufacturer's bodywork anti-perforation/corrosion warranty, usually for a period of six years. A condition of these warranties is that the bodywork must be examined annually for damage/ corrosion. For most Service vehicles, this examination can be carried out by a REME tradesman /MT Technician (RAF) or civilian equivalent. A bodywork warranty examination form has been compiled for recording these examinations and is reproduced at Annex A to this AESP. Rectification of any damage found on the paintwork/underbody protection, during the warranty period, is to be carried out by a manufacturer's recognised local dealer for the vehicle type. For vehicles located in remote areas overseas, where it is not feasible for it to be returned to a manufacturer's local agent, the warranty terms cannot be complied with and rectification necessary should be carried out by the unit. The warranties normally cover corrosion that perforates a panel from the inside as a result of defective materials or workmanship. They do not cover corrosion that has resulted from damage to exterior paintwork or underbody protection from exterior sources. Once a vehicle's bodywork warranty has expired, the annual examination of the body is still to be carried out. However, any rectification work is to be carried out at unit level where possible.

LARGE GOODS VEHICLES, COACHES AND SPECIALIST VEHICLES

Vehicle chassis and sub-chassis.

5 The vehicle chassis and sub-chassis is to be examined annually for surface corrosion. If corrosion is found, it is to be removed and the area repainted. Minor corrosion can be mechanically removed and the affected area repainted by the user/MT Mech/Tech (RAF) taking advice as necessary from REME tradesmen, (P&F) MOD civilian or contract tradesmen. Heavy chassis corrosion should be removed and the affected area treated then repainted by (P&F) MOD civilian or contract tradesmen or at 2nd or 3rd line as necessary.

Coach bodies.

6 Coach bodies are constructed with a steel or alloy frame, mounted onto the vehicle chassis or sub-chassis. The frames are covered with painted aluminium and fibre-glass exterior panels. The frame is normally wax-injected during vehicle manufacture and it is not necessary to re-apply during the life of the vehicle. Coach bodies and their frames are to be examined annually for corrosion. Any minor corrosion found is to be removed and the area repainted. Heavy corrosion is to be removed and the affected area treated then repainted by (P&F) MOD civilian or contract tradesmen or at 2nd or 3rd line as necessary.

Vehicle cabs.

7 All vehicle cabs are to have the following examination/corrosion prevention measures carried out:

7.1 The exterior of the cab, including the underside, is to be cleaned and examined annually for damage to the paintwork and for corrosion. Any damage to the paintwork is to be rectified immediately and any corrosion is to be removed and the area retreated/repainted. In instances where cabs or bodies are manufactured from non - metallic materials, fibre glass, plastic, etc whilst corrosion is not likely to effect these components, they should still be examined where they contribute to the overall strength of the vehicle. All metallic supporting framework, box sections and attachments should be treated as necessary.

7.2 At the 1st maintenance interval, as called for in the respective AESP Category 6 Maintenance Schedule, the cab is to be examined to ascertain that box sections and the underside of the floor pan have been sprayed with manufacturer's corrosion preventative compound (CPC). If the cab has been treated and the CPC is in good condition then record this fact in the Vehicle document FMT 1004 within the FMT1000 series for both Army and RAF. If the cab has not been sprayed with a CPC or the covering is found to be inadequate, then PX 28, NSN 8030-99-657-7708 is to be sprayed into all hollow box sections, inside doors and on the underside of the floor pan where no underbody protection exists. This application of PX 28 should be carried out by REME tradesmen or (P&F) MOD civilian or contract tradesmen or at 2nd or 3rd line as necessary, and recorded in the AB 562 (Army) or on STAMA and the vehicle record card (4870) (RAF). Information on applying PX 28 is at Paras 13 to 16.

Specialist vehicle bodies.

8 The following examination and corrosion prevention measures are to be carried out on the bodies of specialist vehicles:

8.1 Interior and exterior bodywork and any supporting framework is to be cleaned and examined annually for damage to paintwork and for corrosion. If any damage or corrosion is found it is to be rectified immediately.

8.2 At the 1st maintenance interval, as called for in the respective vehicle AESP Category 6 Maintenance Schedule, the bodywork is to be examined to ascertain that box sections and panels on the underside or in hidden/non-cosmetic areas have been sprayed with manufacturer's CPC. If the body has been treated and the compound is in good condition, then record this fact in the Vehicle document FMT 1004 within the FMT1000 series for both Army and RAF. If the body has not been sprayed with a CPC, or the covering is found to be inadequate, then PX 28 is to be sprayed into all hollow box sections and onto unprotected panels on the underside or in hidden/non-cosmetic areas of the body. This application of PX 28 should be carried out by REME tradesmen or (P&F) MOD civilian or contract tradesmen at 2nd or 3rd line as necessary, and recorded in the Vehicle document FMT 1004 within the FMT1000 series for both Army and RAF. Information on the application of PX 28 is given in this AESP.

Lifting equipment superstructures, booms, masts and jibs.

9 Superstructures, booms, masts and jibs of all lifting equipment are to be examined annually for damage to paintwork and for corrosion. Minor corrosion can be mechanically removed/repainted by the user/MT Mech/Tech (RAF), taking advice as necessary from REME tradesmen or (P&F) MOD civilian or contract tradesmen. Heavy corrosion should be removed, and the affected area treated then repainted by (P&F) MOD civilian or contract tradesmen or at 2nd or 3rd line as necessary.

TRAILERS

Trailer chassis.

10 Trailer chassis and sub-chassis are to be examined as per Para 0.

Trailer bodies.

11 The bodies of trailers are to be examined as follows:

11.1 Annually, bodywork and any supporting framework is to be examined for corrosion and damage to the paintwork. Any damage or corrosion found is to be rectified immediately.

11.2 The body is to be examined and treated with PX 28 if necessary as per Para 8.2

VARIATIONS IN EXAMINATION AND CORROSION PREVENTION PROCEDURES

12 Any variations to the procedures listed in this AESP, required to comply with manufacturer's warranty conditions, will be identified in individual vehicles manufacturer's literature or AESP

Category 6 Maintenance Schedules as applicable. When new panels or repaired sections of a vehicle cab/body are fitted, the internal surface of the panels/ box sections are to be sprayed with PX 28 prior to the vehicle being returned to use.

VEHICLE CORROSION PREVENTION PROCEDURES APPLICATION OF PX 28

WARNINGS

(5) **HEALTH HAZARD. PERSONNEL SPRAYING PX 28 ARE TO WEAR THE APPROPRIATE PROTECTIVE CLOTHING AND RESPIRATOR/BREATHING EQUIPMENT IN ACCORDANCE WITH MANUFACTURERS SAFETY DATA SHEETS AND/OR JSP 437**

(6) **HEALTH HAZARD. PERSONNEL ARE TO BE CONVERSANT WITH THE HEALTH HAZARDS AND SAFETY PRECAUTIONS CONTAINED ON THE SAFETY DATA SHEET PRIOR TO SPRAYING PX 28.**

(7) **HEALTH HAZARD. APPLICATION OF PX 28 IS TO BE CARRIED OUT IN VEHICLE SPRAY BAYS/BOOTHES WITH BUILT IN EXTRACTION FACILITIES OR IN DESIGNATED AREAS AS APPROVED BY LOCAL HEALTH AND SAFETY MANAGEMENT, IN ACCORDANCE WITH REGULATIONS LAID DOWN UNDER THE H AND SW ACT 1974 AND LOCAL FIRE ORDERS.**

(8) **FIRE HAZARD. AFTER SPRAYING PX 28 IN/ONTO A VEHICLE THE VEHICLE IS NOT TO BE USED/DRIVEN FOR AT LEAST FOUR HOURS. IDEALLY THE VEHICLE SHOULD BE LEFT INSIDE THE SPRAY BAY OVERNIGHT TO ALLOW THE PX 28 TO DRY OFF.**

CAUTION

(1) **MASKING. Where necessary and before spraying, mask off any brake components, electrical wiring, plastic pipes/hoses and mechanical linkages etc.**

Preparation.

13 Prior to the application of PX 28, the underside of the vehicle must be thoroughly power cleaned and dried. To enable PX 28 to be sprayed it must be warmed, by decanting a quantity into a container and placing the container in hot water. PX 28 should not normally be thinned. However, in cold climates or conditions where it is impossible to spray without dilution, it is permissible to thin the PX 28 with up to a maximum of 20% white spirit. The spray pattern/coverage from the spray gun/nozzles being used should be checked by spraying into a cardboard box prior to treating a vehicle.

Spraying equipment.

14 The following equipment is to be used to spray PX 28:

14.1 Enclosed box sections. A spray gun, with rigid and flexible nozzle extension lances should be used. These should be available at authorised vehicle spray booths/bays with kits consisting of:

14.1.1 Spray gun.

14.1.2 Long rigid extension lance 1100 x 8 mm (metal) giving 360 degrees spray at right angles from the lance.

14.1.3 Flexible nylon extension hose 1300 x 8 mm giving 360 degrees spray at right angles to the hose end.

14.1.4 Rigid hook nozzle 300 x 4 mm giving a forward spray. The air supply to this spray gun should be regulated to between 3 - 6 bar (40-80 lbf/in²).

14.2 Open panels. A high volume low pressure (HVLP) type spray gun must be used whenever PX 28 is sprayed onto open panels (in accordance with EC Volatile Organic Compound Regulations). HVLP spray guns are available under Section, Ref numbers 4940-99-915-3666 and 4940-99-225-5425. These are only available to authorised vehicle spray booths/bays

Vehicle cabs.

15 The following procedures are to be followed:

15.1 Cab preparation. Before treatment, the cab interior trims and door trims should be removed as necessary by a REME tradesman or MT Mech/Tech (RAF) or civilian equivalent, to give access to any box sections. The instrument panel/dashboard headlining need not be removed. Remove any loose material/dust from inside the cab/panels as necessary using a vacuum cleaner. Most box sections will have manufacturer's holes to facilitate spraying. Any box sections that do not have suitable access are to have 10 mm diameter holes drilled by a REME tradesman or MT Mech/Tech (RAF) or civilian equivalent as follows:

15.1.1 On long vertical box sections, 2 holes should be drilled, one approximately a third of the way up and the other, two thirds.

15.1.2 On short vertical sections, a single hole should be drilled midway.

15.1.3 On horizontal or diagonal sections, holes should be drilled at approximately 900 mm intervals.

Any holes drilled in box sections should be in non-cosmetic areas, for example on the inside or underside of the cab or in areas that are normally covered by a trim panel. Bare metal created by the drilling of extra holes is to be painted prior to the application of PX 28. After application of the PX 28 these additional holes are to be plugged using grommets (NSN 6MT 5340-99-810-8172), or equivalent.

15.2 Application. The shaded areas marked on **Error! Reference source not found.** to Fig 4, give representative examples of the box sections of a vehicle cab to be treated with PX 28. When the rigid and flexible extension lances are used, they should be fully inserted into the box section/panel and then slowly withdrawn with the spray gun trigger fully applied. When using the hook nozzle, the nozzle end should be inserted into the panel/section and directed at the area to be treated with the spray gun trigger fully applied. The cab should be treated in separate areas as follows:

15.2.1 Cab front. Raise the cab front grille and identify all box sections to be treated. Remove plugs/grommets from box section access holes. Spray PX 28 into all box sections using a flexible nozzle extension or hook nozzle as necessary. Refit plugs/grommets.

15.2.2 Cab sides. Open the cab doors, locate box sections and remove any plastic plugs/grommets from existing manufacturer's holes. PX 28 should be sprayed into all the box sections using the rigid or flexible nozzle extension. Refit plastic plugs/grommets to holes as necessary.

15.2.3 Cab doors. Open cab doors and ensure the windows are raised. Spray PX 28 up into the box section window frames, using the rigid and flexible nozzle extensions as necessary. Using the hook nozzle extension, spray PX 28 inside the door cavity below the window frames, paying particular attention to all welded and folded joints and strengtheners in contact with the outer skin.

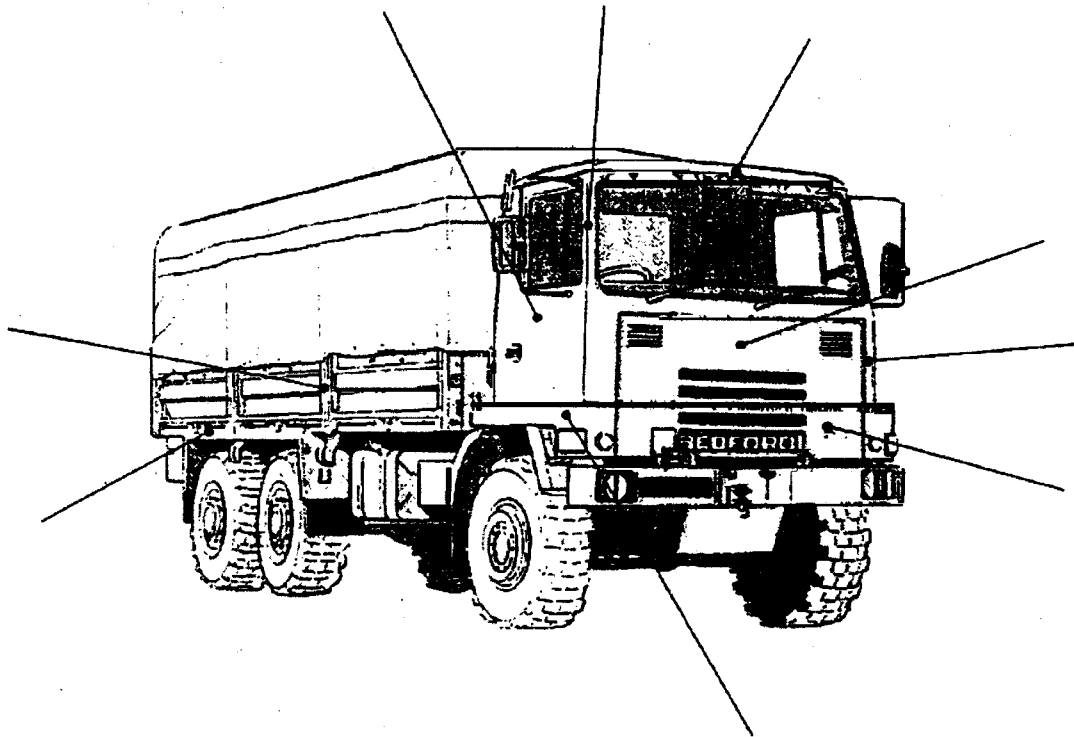


Fig 1 Examples of enclosed box sections to be found at the front and sides of a vehicle cab/body

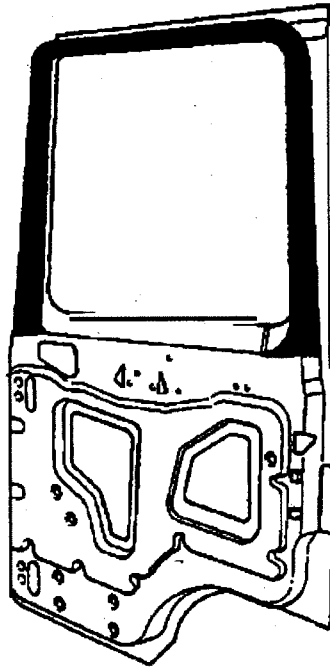


Fig 2 Examples of box sections to be found on a cab door

15.2.4 Cab rear. Identify all box sections on the cab rear and remove any plugs/grommets from access holes. Spray PX 28 into all box sections, using the rigid and flexible nozzle extensions as necessary through all available holes. Refit plugs/grommets.

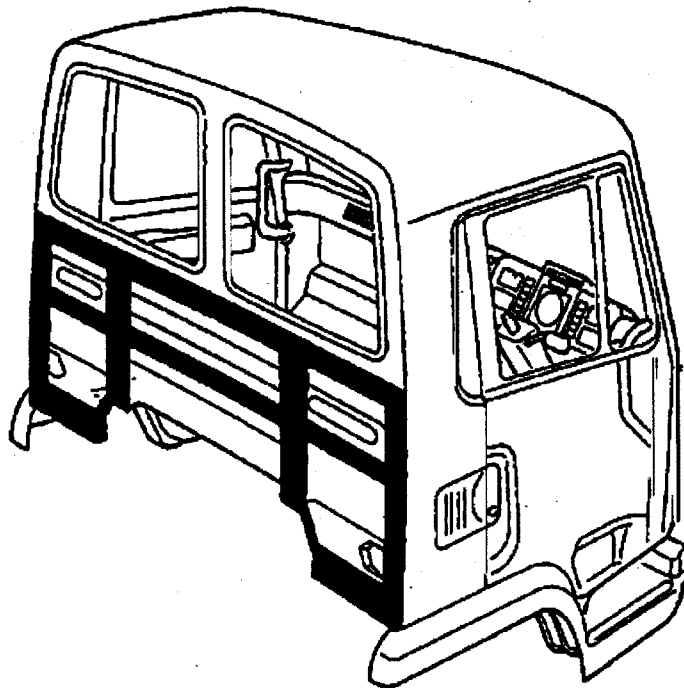


Fig 3 Examples of box sections to be found at the rear of a cab

15.2.5 Cab underside/floor Tilt the cab, identify all enclosed box sections on the cab floor and remove any plugs/grommets from access holes. Spray PX 28 into the box sections using the rigid and flexible nozzle extensions as necessary, through all access holes. Refit plugs/grommets. Spray any panels on the underside of the cab floor that are not coated with underbody sealant with PX 28, using a HVLP spray gun and lower the cab. From inside the cab, spray PX 28 into any box sections that have not been treated. After spraying PX 28, ensure that all manufacturer's drainage holes on the vehicle are clear.

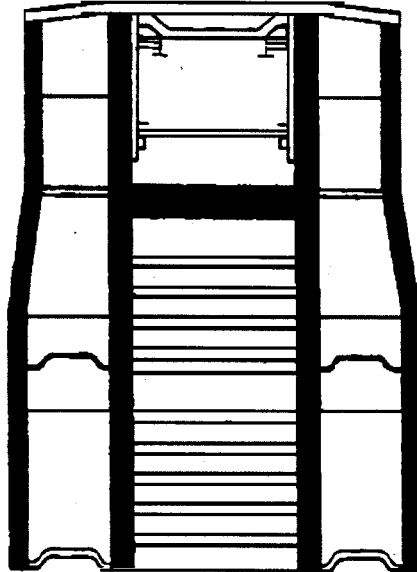


Fig 4 Examples of box sections to be found on the underside/floor of a vehicle cab

Specialist vehicles, trailers and bodies

16 The following procedures are to be followed when applying PX 28 to specialist vehicles, trailers and bodies:

16.1 Preparation. Any loose equipment should be removed and stowed away from the vehicle. If necessary, trim panels should be removed by a REME tradesman or MT Mech/Tech (RAF) or civilian equivalent to give access to areas that require spraying. Examine the body structure of the vehicle or trailer and note the position of any enclosed box sections and whether there are sufficient access holes. Any box sections that do not have sufficient access holes are to have 10 mm diameter holes drilled in accordance with Para 15. Note the position of any unprotected aluminium panels on the underside. If necessary, mask up electrical wiring, brake components, plastic pipes/hoses and mechanical linkages adjacent to open panels that are to be sprayed. of the vehicle and in hidden non-cosmetic areas, particularly where they are in contact with steel supporting frames/structures. Remove any loose material or dust with a vacuum cleaner.

16.2 Application. Remove any plugs/grommets and spray PX 28 into all steel enclosed box sections using a spray gun with rigid or flexible extension lance as necessary. The interior surfaces of door cavities are to be sprayed using the hook nozzle extension. The interior surfaces of any hidden/non-cosmetic steel sheet or aluminium sheet body panels and any unprotected aluminium or steel panels on the underside of the vehicle, are to be sprayed using a HVLP spray gun. Particular attention should be paid to all welded and folded joints and strengtheners supporting frames in contact with the outer skin. After spraying, ensure that any manufacturer's drainage holes are clear. Refit plugs/grommets.

ANNEX A

VEHICLE BODYWORK WARRANTY

EXAMINATION FORM

Fig		Page
1	Example of light/medium vehicle body	2
Table		Page
1	Record of bodywork defects	4

ANNEX A

VEHICLE BODYWORK WARRANTY EXAMINATION FORM

NOTES

- (9) This form is to be photocopied and used to record in-house vehicle bodywork warranty examinations on light/medium vehicles.
- (10) The Figure below shows a representative example of a light/medium vehicle body with panels to be examined.
- (11) Any damaged bodywork/paintwork found during the examination is to be recorded in Table 1, for example stone chips on the bonnet should be recorded with the words 'stone chips' against Serial 2. A dent on the front l.h. wing would be recorded with the word 'dent' against Serial 4.
- (12) If damaged bodywork/paintwork is found, arrangements to get the damage repaired should be initiated as soon as possible.
- (13) The completion of the bodywork examination should be documented on this form by using the unit stamp and signature by the MT WO/SNCO or MT TECH NCO.
- (14) The form is to be retained with the vehicles Vehicle document FMT 1004 within the FMT 1000 series/maintenance documents for the duration of the vehicle's bodywork warranty - normally six years from the date into service.

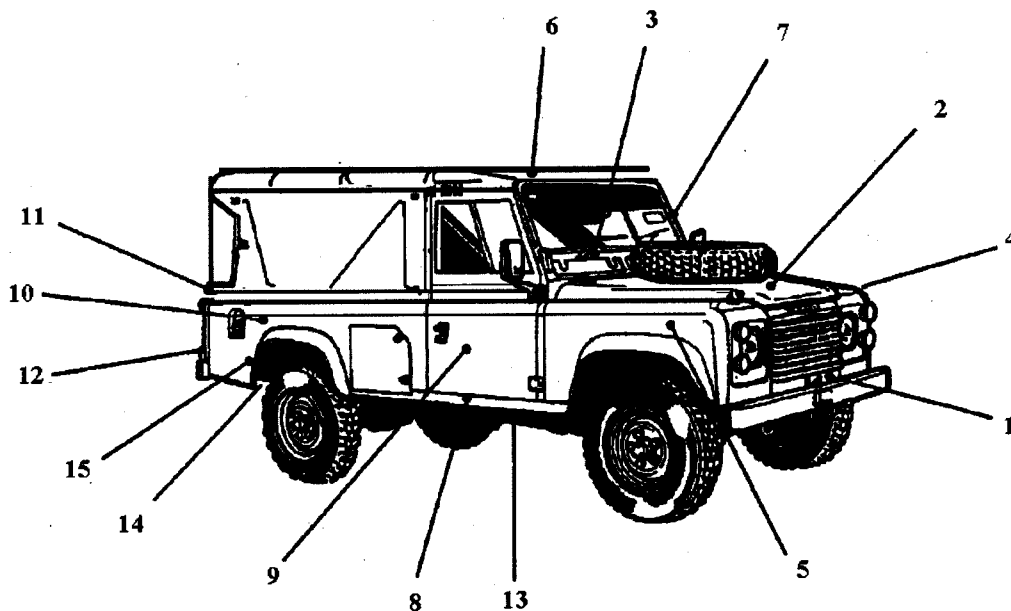


Fig 5 Example of light/medium vehicle body



TABLE 1 RECORD OF BODYWORK DEFECTS

Serial	Body Area	Comments
1	Front Panel/Valance	
2	Bonnet	
3	Windscreen Surround	
4	LH Front Wing	
5	RH Front Wing	
6	Roof	
7	LH Front Door	
8	Sills	
9	RH Front Door	
10	RH Rear Wing/Bodyside Panel	
11	Boot/Tailgate/Rear Door(s)	
12	Rear Panel/Valance	
13	Floor Pan	
14	Chassis Legs/Crossmembers	
15	Front and Rear Wheel Arches	
16	Miscellaneous Body Panels	
17		
18		
19		

EAC: _____	REGISTRATION NO: _____
VEHICLE TYPE _____	VEHICLE MILEAGE: _____
UNIT STAMP:	SIGNATURE:

If required this form should be adapted locally and used on Large Goods Vehicles, Coaches and Trailers.

COMMENT(S) ON AESP*

To: FRACAS BFPO 794

From:

.....
.....
.....

Senders Reference	BIN Number	Date
AESP Title: B VEHICLE CORROSION PREVENTION - TECHNICAL DESCRIPTION		
Chapter(s)/Instruction	Page(s)/Paragraph(s)	
If you require more space please use the reverse of this form or a separate piece of paper. Comment(s):		

Signed: Telephone No.:

Name(Capitals): Rank/Grade: Date:

✕

FOR AESP* SPONSOR USE ONLY

TO: FROM:

.....
.....
.....

Thank you for commenting on AESP*: 2300-A-310-201.....

Your reference: Dated:

Action is being taken to:	Tick		Tick
Issue a revised/amended AESP*		Under investigation	
Incorporate comment(s) in future amendments		No action required	
Remarks			

Signed: Telephone No.:

Name(Capitals): Rank/Grade: Date:

* AESP or EMER



Ministry of Defence

WATERPROOFING REGULATIONS VEHICLES AND EQUIPMENT

Sponsored for use in the
UNITED KINGDOM MINISTRY OF DEFENCE
AND ARMED FORCES
By

DES LE PEng-Eng

Publication Authority
11 Amphibious Trials and Training Squadron
1 Assault Group Royal Marines
N5612A

CONDITIONS OF RELEASE

~~This information is released by the UK Government for Defence purposes only.~~

~~This information must be afforded the same degree of protection as that afforded to information of an equivalent classification originated by the recipient Government or as required by the recipient Government's National Security regulations.~~

~~This information may be disclosed only within the Defence Department of the recipient Government, except as otherwise authorized by the Ministry of Defence (Army).~~

~~This information may be subject to privately owned rights.~~

~~THIS DOCUMENT IS THE PROPERTY OF HER BRITANNIC MAJESTY'S GOVERNMENT, and is issued for the information of such persons only as need to know its contents in the course of their official duties. Any person finding this document should hand it in to a British forces unit or to a police station for its safe return to the Ministry of Defence, (DDef Sy), Main Building, Whitehall London, SW1A 2HB, with particulars of how and where found. THE UNAUTHORIZED RETENTION OR DESTRUCTION OF THIS DOCUMENT IS AN OFFENCE UNDER THE OFFICIAL SECRETS ACTS OF 1911-1989. (When released to persons outside Government service, this document is issued on a personal basis. The recipient to whom it is entrusted in confidence, within the provisions of the Official Secrets Acts 1911-1989, is personally responsible for its safe custody and for seeing that its contents are disclosed only to authorized persons).~~

© CROWN COPYRIGHT RESERVED

AMENDMENT RECORD

Amdt No.	Incorporated By (Signature)	Date
1		
2		
3		
4		
5		
6		
7		
8		
9		
10		
11		
12		
13		
14		
15		
16		
17		
18		
19		
20		
21		
22		
23		
24		
25		
26		
27		
28		
29		
30		
31		

Amdt No.	Incorporated By (Signature)	Date
32		
33		
34		
35		
36		
37		
38		
39		
40		
41		
42		
43		
44		
45		
46		
47		
48		
49		
50		
51		
52		
53		
54		
55		
56		
57		
58		
59		
60		
61		
62		

PAGE LEFT INTENTIONALLY BLANK

CONTENTS

PRELIMINARY MATERIAL	Page
Front cover (title page)	(i)
Conditions of release.....	(ii)
Amendment record.....	(iii)
Contents (this list).....	(v)
Preface	(vi)
Introduction.....	(vi)
Amendments	(vi)
Related and associated publications.....	(vi)
Abbreviations.....	(vii)
COMMENT(S) ON AESP	Final leaf

POLICY AND PROCEDURES

Chapter

- 1 Waterproofing aspects of amphibious operations
- 2 Waterproofing materials and their usage
- 3 Waterproofing and its effects on servicing and repair
- 4 Driving of waterproofed equipment and beach recovery
- 5 Treatment of drowned vehicles after recovery

PREFACE

Sponsor: DES LE PEng-Eng
 Project Number: LE029
 File Ref: PfmO/PEng/17/069
 Publication Authority: 11 Amphibious Trials and
 Training Squadron

INTRODUCTION

1 Service users should forward any comments on this publication through the channels prescribed in Army Equipment Support Publication (AESP) 0100-P-011-013. An AESP Form 10 is provided at the end of this publication; it may be photocopied and used for forwarding comments on this AESP, if unable to send electronically. An electronic Form 10 can be found on TDOL and JAMES, this is the preferred method of submitting Form 10s.

2 The AESP Form 10 in this publication is Unclassified. Where comments made are of a classified nature, the completed form is to be annotated with the appropriate Protective Marking. Security procedures are to be observed in accordance with Joint Services Publication (JSP) 440.

3 This procedure is only to be used for the purpose of commenting on the content of an individual AESP and must not be used in place of the equipment defect reporting procedure as outlined in the Defence Logistic Framework (DLF).

4 Where AESPs specify action to be taken, the AESP will be itself sufficient authority for such action and also for the demand of the necessary stores, subject to provisions of Para 6.

5 The subject matter of this publication may be affected by Defence Instructions and Notices (DINs), Standard Operating Procedures (SOPs) or by local regulations. When any such Instruction, Order or regulation contradicts any portion of this publication, it is to be taken as the overriding authority.

AMENDMENTS

6 New or amended material will be indicated by vertical margin lines to show the extent of the amendment in accordance with AESP 0100-P-009-013.

RELATED AND ASSOCIATED PUBLICATIONS

7 The associated publications are as follows:

Reference	Title
DEFENCE STANDARD 00-006	Fording and Flotation Requirements for Combat and Support Ground Vehicles. Information: www.dstan.mod.uk
STANAG 2805	Fording and Flotation Requirements for Combat and Support Ground Vehicles. Information: www.dstan.mod.uk
BR 6600	Control of Substances Hazardous to Health Regulations (COSHH). Information: www.hse.gov.uk/coshh
JSP 515	Hazardous Stores Information System 2 (HSIS 2). Information: www.transportsafety.dii.r.mil.uk

ABBREVIATIONS

Abbreviation	Nomenclature
1 AGRM	1 Assault Group Royal Marines
3 Cdo Bde RM	3 Commando Brigade Royal Marines
11(ATT) Sqn	11 Amphibious Trials and Training Squadron
ABU	Amphibious Beach Unit
AESP	Army Equipment Support Publication
BR	Book of Reference
BRV	Beach Recovery Vehicle
CES	Complete Equipment Schedule
CINCFLEET	Commander In Chief Fleet
COSHH	Control Of Substances Hazardous to Health
CST	Close Support Tanker
DE&S	Defence Equipment and Support
DR TDOL	Design Repository Technical Documents on Line
DROPS	De-mountable Rack Offload and Pickup System
DSDA	Defence Storage and Distribution Agency
DSEME	Defence School of Electrical and Mechanical Engineers
DST	Defence School of Transport
DVP	Drowned Vehicle Park
EAC	Equipment Asset Code
EFR	Equipment Failure Report
ES	Equipment Support
FEPS	Field Electrical Power Supplies
FFR	Fitted For Radio
FRACAS	Failure Reporting And Corrective Action System
ft	Feet
GS	General Service
GW	Guided Weapon
HQ 3 Cdo Bde RM	Headquarters 3 Commando Brigade Royal Marines
IMM	Improved Medium Mobility
In.	inch

(continued)

ABBREVIATIONS (continued)

Abbreviation	Nomenclature
JNCO	Junior Non-Commissioned Officer
JSP	Joint Service Publication
Km/h	Kilometres an hour
LCU	Landing Craft Utility
LCVP	Landing Craft Vehicle Personnel
LPD	Landing Platform Dock
LSD	Landing Ship Dock
m	meter
mm	millimetre
MM	Medium Mobility
MMLC	Medium Mobility Load Carrier
mph	Miles per hour
MTO	Motor Transport Officer
NATO	North Atlantic Treaty Organisation
NSN	NATO Stock Number
PT	Project Team
PVC	Polyvinyl Chloride
RA	Royal Artillery
REME	Royal Electrical Mechanical Engineers
RLC	Royal Logistic Corps
SNCO	Senior Non-Commissioned Officer
SOP	Standard Operating Procedure
SRD	System Requirements Document
STANAG	NATO Standardization Agreement
STTE	Special Tools and Test Equipment
SV	Support Vehicle
TAR	Tactical Aircraft Refueller
TBC	To Be Confirmed
TCV	Troop Carrying Vehicle
TES TI	Technical Enabling Services - Technical Information
TUL	Truck Utility Light
TUM	Truck Utility Medium
UST	Unit Support Tanker

(continued)

ABBREVIATIONS (continued)

Abbreviation	Nomenclature
VM	Vehicle Mechanic
WMIK	Weapons Mount Installation Kit

PAGE LEFT INTENTIONALLY BLANK

CHAPTER 1

WATERPROOFING ASPECTS OF AMPHIBIOUS OPERATIONS

CONTENTS

Para

	Introduction
1	Operational requirement
4	Aim
	Technical aspects of waterproofing
5	Waterproofing standards
6	Unprepared Fording
7	Unprepared Fording depths
8	Prepared Fording
9	Prepared Fording depths
12	Readiness to operate after fording
14	Tactical considerations
15	Drowned Vehicle Parks
16	Recovery
	Detailed technical considerations
17	Kit waterproofing, semi-permanent
19	Stage 'A' waterproofing (CAUTION)
20	Stage 'B' waterproofing
21	Stage 'C' de-waterproofing
22	Stage 'D' de-waterproofing
25	Training
29	Technical services
	General related matters
31	Beaches
33	Loading and stowage
34	Prepared Fording cycle
35	Waterproofed equipment markings

Table

	Page
1	Semi-permanent waterproofing equipment markings10
2	Semi-permanent waterproofing stages (A-D)11
3	LCU Mk 10 Beaching15
4	Vehicles unsuitable for fording16
5	Vehicles and equipment waterproofing kits16

Fig

	Page
1	Prepared Fording Cycle9
2	Waterproofed equipment markings10

INTRODUCTION

Operational requirement

1 During the types of operation listed below, it is essential for equipment to be able to ford fresh and sea water gaps and retain an ability to fight during or soon after the crossing:

- 1.1 Opposed and unopposed water crossings.
- 1.2 Seaborne landings.
- 1.3 Fighting in marshy or tidal areas.
- 1.4 Fighting and/or movement in areas (particularly those below sea or river level) exposed to flash floods or enemy released flood waters.

2 Service equipment has the ability to ford without preparation at a depth determined by their construction. In the case of equipment where this depth is insufficient to enable them to carry out the operational requirement at Para 1.1 to 1.4, it is necessary to have a facility to waterproof this equipment.

3 Equipments may gain the ability to ford without detriment to their operational performance in three ways:

- 3.1 MOD System Requirements Document (SRD) ensures equipment design meets minimum fording category (Unprepared Fording).
- 3.2 By fitting a permanent waterproofing installation (Unprepared Fording).
- 3.3 By having a special waterproofing kit applied to the equipment before fording (Prepared Fording).

Aim

4 The aim of this Army Equipment Support Publication (AESP) is to assist HQ's staff, Equipment Support (ES) staff and personnel engaged in amphibious activities, to gain an understanding of the technical aspects of waterproofing.

TECHNICAL ASPECTS OF WATERPROOFING

Waterproofing standards

5 The Defence Standard 00-006 titled 'Fording and Flotation Requirements for Combat and Support Ground Vehicles' contains the relevant standards for waterproofing and gives definitions as follows:

Unprepared Fording

6 The capability of a combat or support ground vehicle with its wheels or tracks in contact with the ground, to negotiate a water obstacle without prior preparation. The use of built-in waterproofing will increase the depth to which mobile equipment is capable of unprepared fording and may be necessary to meet minimum fording requirements:

- 6.1 Ideally, Unprepared Fording should be possible without preparation but where preparation cannot be avoided the time taken for this operation is not to exceed 5 minutes, in all conditions. Preparation shall not involve fittings which are not part of the mobile equipment and shall be within the capability of the crew using normal hand tools supplied as part of the usual tool kit, carried on the mobile equipment.

6.2 Mobile equipment is to be capable of Unprepared Fording continuously for up to 2 hours at a ground speed of 8-13 km/h (5-8 mph). During fording the engines of self-propelled mobile equipment must be capable of being stopped for up to 10 minutes and restarted. The equipment must be capable of operating in reverse at its maximum fording depth

Unprepared Fording depths

7 The variety and complexity of mobile equipment now in service makes it impracticable to specify a standard for Unprepared Fording depths. But the SRD for each equipment will state the depth required, and the final specifications must state the agreed Unprepared Fording depth. Where possible the depth required should be indicated by invoking one of the following categories:

- 7.1 Amphibious plant vehicles – 1500 mm (60 in.) plus 500 mm (20 in.) splash height.
- 7.2 Heavy armoured fighting vehicles – 1500 mm (60 in.).
- 7.3 Light armoured vehicles and high mobility 'B' vehicles (payload over 4 tonne) – 1250 mm (50 in.).
- 7.4 Other vehicles – 750 mm (30 in.).

Prepared Fording

8 The capability of a combat or support ground vehicle with its wheels or tracks in contact with the ground, to negotiate a water obstacle by prior application of a special waterproofing kit. The incorporation of some built-in waterproofing may simplify the waterproofing kit and have the added advantage of increasing the Unprepared Fording depth.

Prepared Fording depths

9 The following combat and support ground vehicles, preferably with built-in waterproofing or by the use of special waterproofing kits, shall be capable of Prepared Fording for 6 minutes continuous driving at the depths indicated:

- 9.1 All vehicles, irrespective of size that are required for amphibious operational purposes – 1500 mm (60 in.) plus 500 mm (20 in.) splash height.
- 9.2 Trailed loads less than 1,500 mm in height could obviously be subject to complete immersion if they do not float. Trailed loads should not float while being towed by a vehicle which itself is in the water, and which is obtaining its traction by contact with the ground.

10 The 'fording depth' refers to the effective depth of water the vehicle equipment can negotiate including ramp angle, wheel sink and wave height.

11 The waterproofing kits used to achieve these depths by Prepared Fording should be of a two stage, semi-permanent design; Waterproofing Stage 'A' and Waterproofing Stage 'B'.

Readiness to operate after fording

12 Self-propelled equipment must be capable of completing its battlefield mission after very minor servicing/removal of any special waterproofing kit. This servicing/removal should take no longer than 15 minutes to complete. To permit the equipment to clear the immediate beach area it is permissible for the equipment to operate for a period of up to one hour after leaving the water.

13 Self-propelled and towed guns are to be capable of being brought into action immediately after any fording equipment has been removed or stowed.

Tactical considerations

14 Although waterproofing is essentially a 'G3' staff requirement, it will be necessary for the staff to work in close co-operation with the Defence Equipment & Support, Project Team (DE&S, PT) and 11 Amphibious Trials and Training Squadron, 1 Assault Group Royal Marines (11(ATT) Sqn, 1 AGRM) in planning any activity which involves crossing a water gap. It may be that the basic Unprepared Fording capabilities of the equipment involved is sufficient to allow crossings to be effected. This may well be the case in flood conditions or certain ship to shore situations. However, where it is necessary to use waterproofing kits to prepare equipment for Prepared Fording, the logistic services may be called upon as follows:

14.1 DE&S PT. To provide the necessary waterproofing kits. The issue of such kits is controlled by Defence Storage and Distribution Agency (DSDA), Bicester. Demands should be placed through staff channels.

14.2 11(ATT) Sqn, 1 AGRM. To advise on the technical aspects of waterproofing kits including:

14.2.1 Whether it is necessary to waterproof. The depth of water to ford will determine whether some or all of the equipment needs waterproofing.

14.2.2 Whether waterproofing kits have been designed for equipment required to cross the water gap. It may be necessary to develop local ad hoc waterproofing systems, where minor differences exist between actual equipment and the standard equipment for which the waterproofing kits were designed.

14.2.3 The time factors and resources required to carry out the waterproofing task.

Drowned Vehicle Parks

15 During fording, it is likely that some equipment may fail in the water gap. It is necessary to effect recovery of this equipment to a Drowned Vehicle Park (DVP) where they may be quickly made battleworthy before deterioration, due to drowning, sets in. Standard Operating Procedures (SOPs) for the organisation and control of DVPs is a 3 Commando Brigade Royal Marines (3 Cdo Bde RM) responsibility. DVPs must be established according to the requirement. The ES staff at the HQ which is controlling the amphibious operation is responsible for making the necessary arrangements for DVPs within their area.

Recovery

16 The extrication of a casualty in a water gap is a normal Royal Marines Assault Squadron responsibility.

DETAILED TECHNICAL CONSIDERATIONS

Kit waterproofing, semi-permanent

17 The kit waterproofing semi-permanent is of a two stage design. Table 5 gives details of existing semi-permanent kits and related installation times. The first stage (A) is a permanent modification which may be incorporated in the build standard of the equipment or comprise of a modification kit. The second stage (B) is a temporary modification kit which is applied immediately prior to Prepared Fording.

18 Waterproofing for Prepared Fording takes time; it requires good working conditions under cover and technical support. The complete waterproofing of equipment would not normally take place at the point of embarkation or river crossing because of the tactically unacceptable concentration of equipment in one place over a long period of time. Refueling, maintenance and kit stowage are necessary after a long journey; consequently waterproofing is broken down into various stages to avoid a concentration of equipment at the point of departure.

Stage 'A' waterproofing

CAUTION

EQUIPMENT DAMAGE. THE APPLICATION OF STAGE 'A' WATERPROOFING DOES NOT IMPROVE THE FORDING CAPABILITY OF THE EQUIPMENT. THE EQUIPMENT MUST NOT BE SUBJECT TO ANY PREPARED FORDING REQUIREMENT UNTIL THE COMPLETION OF FITTING THE STAGE 'B' WATERPROOFING KIT.

19 Stage 'A' waterproofing comprises the bulk of the work and is a permanent modification to the equipment. This stage of waterproofing is achieved by one of the following methods:

19.1 Build standard modification. Stage 'A' waterproofing is included within the build standard of the equipment by the manufacturer. The equipment is identified as a waterproofed variant by Equipment Asset Code (EAC). Repair and maintenance is defined by the manufacturer in the relevant categories of the AESP Octad for the equipment.

19.2 Stage 'A' modification kit. Alternatively when equipment is required for Prepared Fording after coming into service, stage 'A' waterproofing is completed by the fitting of a modification kit to AESP category 423. The AESP for fitting the kit is controlled and issued by the relevant DE&S PT for the equipment. The AESP must be retained with the vehicle documents to assist in the maintenance and repair of the waterproofing modifications. This kit is designed to be installed by unit tradesmen at workshop level. The date of fitting this kit is to be recorded in the appropriate section of the vehicle record book. There is no restriction on mileage after completion. The relevant categories of the AESP Octad for the equipment will be amended to cover repair/maintenance of waterproofing modifications. When stage 'A' waterproofing kit has been fitted for a period of twelve months, it must be inspected annually by a Senior Non-Commissioned Officer (SNCO) trained in the repair/maintenance of waterproofed equipment.

Stage 'B' waterproofing

NOTE

Control of Substances Hazardous to Health (COSHH) items and compounds which have a shelf storage life are not supplied with waterproofing kits. These items are listed in the AESP instructions and are to be demanded separately by Units prior to undertaking waterproofing preparation.

20 The instructions for Stage 'B' waterproofing are controlled and issued by the appointed DE&S Project Team (PT) for the equipment:

20.1 Technical instructions for waterproofing preparation are completed by one of the following methods:

20.1.1 AESP Category 421 Waterproofing Instruction. Waterproofing preparation is completed by the fitting of a modification kit to instructions contained within the AESP Category 421 for the equipment.

20.1.2 AESP Category 201 Operating Information. Alternatively waterproofing preparation is contained within the Operating Information, AESP Category 201 for the equipment.

20.2 The waterproofing preparation is capable of being installed by a trained driver [REDACTED] using simple hand tools with a minimum of assistance from a Vehicle Mechanic (VM). These are the final tasks before Prepared Fording. Stage 'B' should be completed as near to the point of embarkation as possible and supplies of fuel, oil and lubricants must be available. After completion of stage 'B', pre-ford vehicle running time should be restricted to 15 minutes. Final check of vehicle waterproofing before disembarkation is essential. The waterproofing preparation instructions must be retained by the vehicle crew as they contain all the information to complete the de-waterproofing stages 'C' and 'D'.

20.3 Suitable protection from wind, rain and dust must be provided together with adequate illumination for stage 'B' waterproofing. Sufficient working space must be allowed to complete the waterproofing.

20.4 Full servicing facilities including washing down, fuel, oil and lubricants. (Fuel and oil tanks are prepared at this stage). The equipment must be fully inspected before any waterproofing takes place and any defects rectified. It is useless to ford equipment which is not in a fully serviceable condition.

Stage 'C' de-waterproofing

21 Stage 'C' de-waterproofing tasks should take no longer than 15 minutes to complete. It is permissible for the equipment to operate for a period of up to one hour after leaving the water before this stage is completed. After completion of stage 'C' de-waterproofing, the equipment is capable of completing the battlefield mission. The equipment can re-ford by completing the 'wet shod re-embarkation' instructions contained within the AESP.

Stage 'D' de-waterproofing

22 Stage 'D' de-waterproofing, tasks which are completed at this stage depend on whether the vehicle is to remain and operate on shore indefinitely or re-embark within a few days. Certain tasks may need to be completed within 40 km (25 miles) from point of disembarkation if operationally possible. The remaining tasks should be completed as soon as conditions permit before or after completion of the battlefield mission. After stage 'D' is completed, the vehicle is capable of re-fording by repeating stage 'B'.

23 At stage 'D', it is desirable to have good supplies of fresh water for washing down and fuel, oil and lubricants for draining and refilling any assemblies which have been contaminated.

24 Most waterproofing instructions call for workshop assistance for the completion of some of the tasks. These are mainly the services of a Unit VM or electrician and can be completed with hand tools from a VM tool kit. Units may be heavily involved in waterproofing their own equipment and it could be necessary to call for additional ES from sources outside the force undergoing amphibious preparations. This especially applies to adequate inspection and repair facilities before waterproofing.

Training

25 Training is essential for successful waterproofing and is the responsibility of the unit concerned. It should cover as fully as possible the following:

25.1 Waterproofing and de-waterproofing of vehicles and equipment.

25.2 Inspecting the integrity of the "Build Standard" waterproofing of vehicles and equipment.

25.3 Driver and Vehicle Mechanic (VM) training to cover:

25.3.1 Embarking and disembarking from a Landing Craft Utility (LCU).

25.3.2 Driving in the sea to the maximum fording depth of the vehicle or equipment.

25.3.3 Practice in Drowned Vehicle Recovery techniques.

25.3.4 Driving on soft sand and negotiating difficult beach conditions.

25.4 Instruction of all personnel in beach organisation covering particularly, details of beach recovery, traffic control, Drowned Vehicle Procedure and post ford servicing. The above techniques should be practiced regularly in benign conditions and within the weather and sea condition limitations of the LCU during daylight and dark hours.

26 Units are responsible for the inspection and any subsequent maintenance of the build standard waterproofing (Stage 'A') for all vehicles and equipment on their charge in accordance with the relevant Maintenance Schedule (AESP Category 601). This is a mandatory requirement in order to maintain the waterproofing integrity of the vehicles and equipment.

27 Units are also responsible for the waterproofing of the vehicles and equipment on their charge that are capable of being forded. The waterproofing is to be carried out by personnel who have been suitably trained and under the supervision of a Junior Non-Commissioned Officer (JNCO) who has been trained in waterproofing techniques. Because of the exacting nature of the work and the possibility of catastrophic equipment damage if incorrectly waterproofed, the ratio of supervision should be aimed at one JNCO for every four 'B' type vehicles.

28 Training courses for all aspects of vehicle and equipment waterproofing is the responsibility of the Training Wing, 11(ATT) Sqn, 1AGRM, Instow. The following training courses are available to all Driver and VM branches of 3 Cdo Bde RM. Specialist courses can also be arranged to suit the needs of operational units by contacting Training Wing, 11(ATT) Sqn, 1 AGRM, Instow:

- 28.1 RM D1-D3 Waterproofing Driver courses, sponsored by DST Leconfield.
- 28.2 Motor Transport Officer (MTO) course sponsored by DST Leconfield.
- 28.3 3 Cdo Bde RM driver Waterproofing and Supervisor courses.
- 28.4 Vehicle Mechanic (VM 1-3) course sponsored by DSEME Bordon.
- 28.5 Amphibious Beach Unit (ABU) Plant.
- 28.6 Amphibious Beach Unit VM Beach Recovery Vehicle (BRV).

Technical services

29 The development of waterproofing techniques and the issue of instructions in the form of waterproofing AESPs for each type of equipment is the responsibility of 11(ATT) Sqn, 1 AGRM. DE&S retain the responsibility for technical editing, printing and distribution of the publication.

30 It is a RM responsibility to provide one waterproofing SNCO to each major unit called upon to take part in waterproofing exercises or operations. The training of sufficient waterproofing SNCOs to meet this commitment is a RM responsibility and applications for courses should be addressed to Navy Command HQ. The SNCO is capable of giving advice on all aspects of the waterproofing task to commanders.

GENERAL RELATED MATTERS

Beaches

31 Careful consideration must be given to the nature of the beach on which a landing is to take place. The Staff planning the operation will naturally select one operationally suitable with sufficient beach exits. There are many types of beach and they vary in consistency, the most acceptable being firm sand. The risk of bogging down wheeled vehicles on shingle beaches is very high. Soft deep mud may be impossible to negotiate. Whenever a RM Assault Squadron is involved in the landing the ability to lay Class 30 Trackway to enable 'B' vehicles to negotiate difficult beaches is available.

Loading and stowage

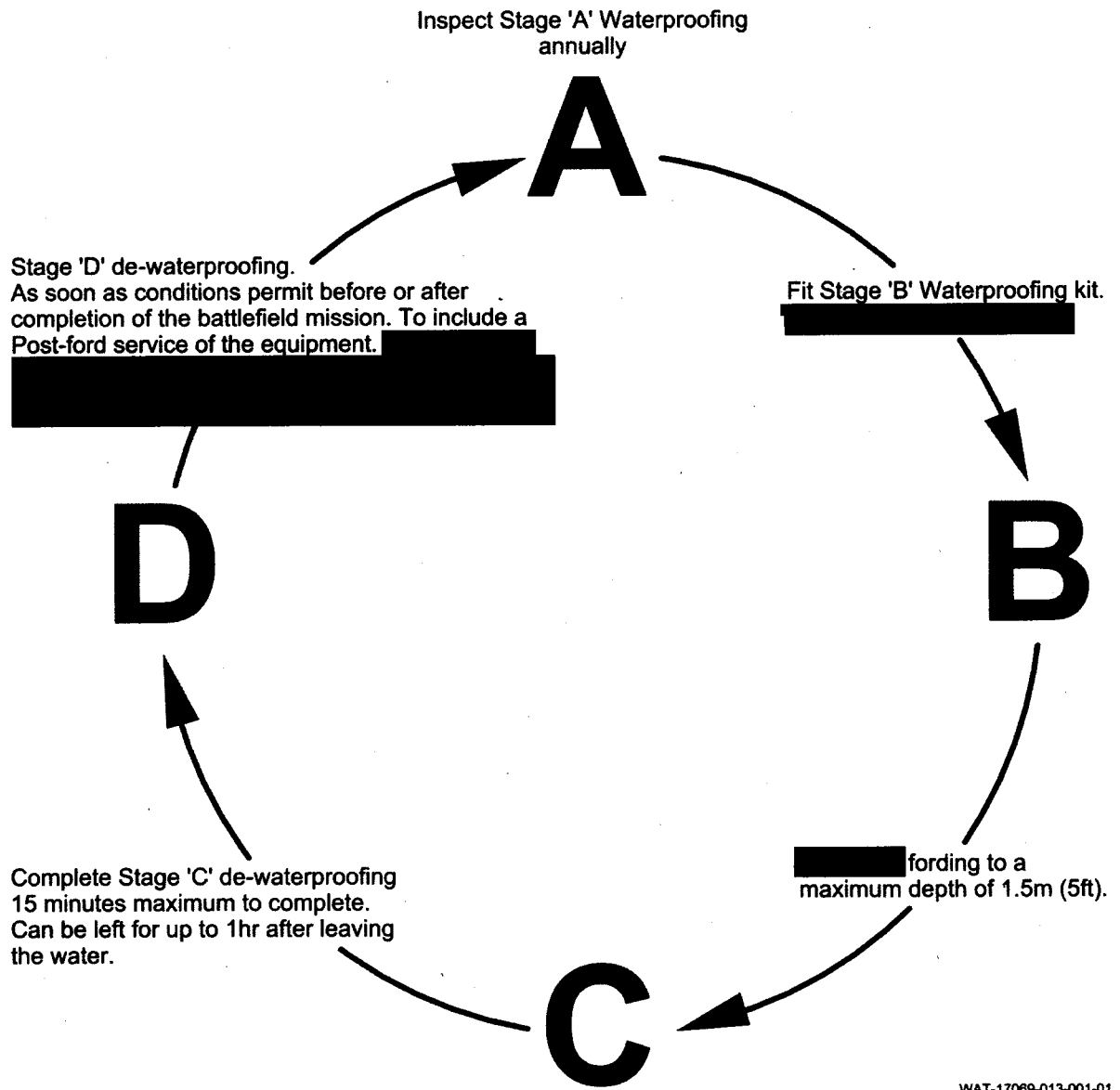
33 If stage 'B' waterproofing is to be completed on board ship, ample space must be left around the waterproofed equipment to enable the tasks to be completed. If the landing craft are to transport equipment direct to the assault beach, loading will be arranged tactically, i.e. the first off will be the last on. All equipment which may have to withstand a long sea voyage, or bad weather, must be securely lashed down. Main battle tanks may have to be pedestalled by placing wooden blocks under the hull of the tank both fore and aft so as to raise the tank hull 25 mm. The purpose of this is:

- 33.1 To provide a more inert load from the cargo point of view.
- 33.2 To spread the load over both tracks and pedestal base.
- 33.3 To prevent tracks sliding on the tank decks.

34 Care must be taken that pedestals do not damage the waterproofing on the underside of the hull. If waterproofed equipment is carried in the holds of cargo vessels for subsequent trans-shipment to landing craft, precautions must be taken that the waterproofing is not damaged by loading slings, hooks or cradles. Care must be taken that sufficient space is allowed around each vehicle for effective lashing down, maintenance, inspection and combating fire. Equipment carried on open decks will be exposed to the weather; therefore, regular inspection of any waterproofing must be carried out. Arrangements must be made for maintenance teams to be carried on these vessels, to check the waterproofing and maintain the equipment.

Prepared Fording cycle

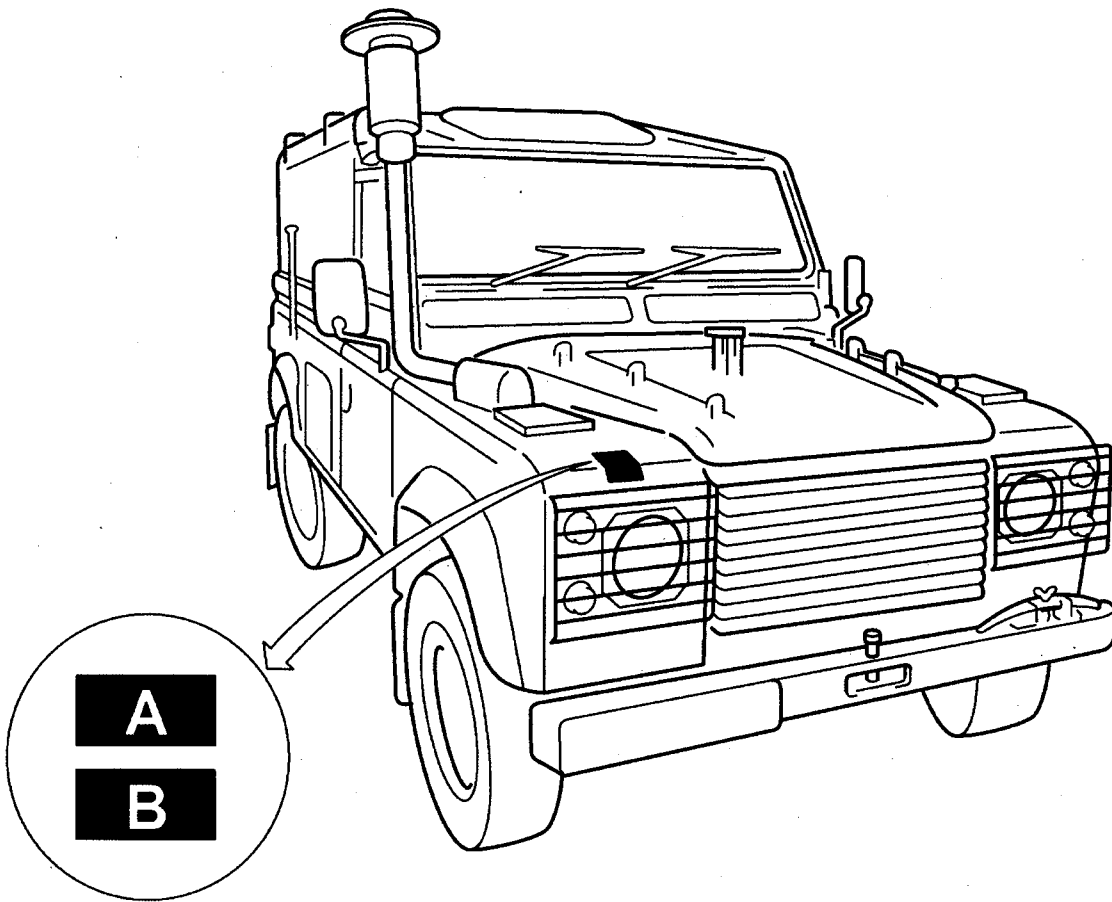
35 The following is an illustration describing the Waterproofing 'Stages' for Prepared Fording.



WAT-17069-013-001-01

Fig 1 Prepared Fording Cycle



Waterproofed equipment markings



WAT-17069-013-002-01

Fig 2 Waterproofed equipment markings

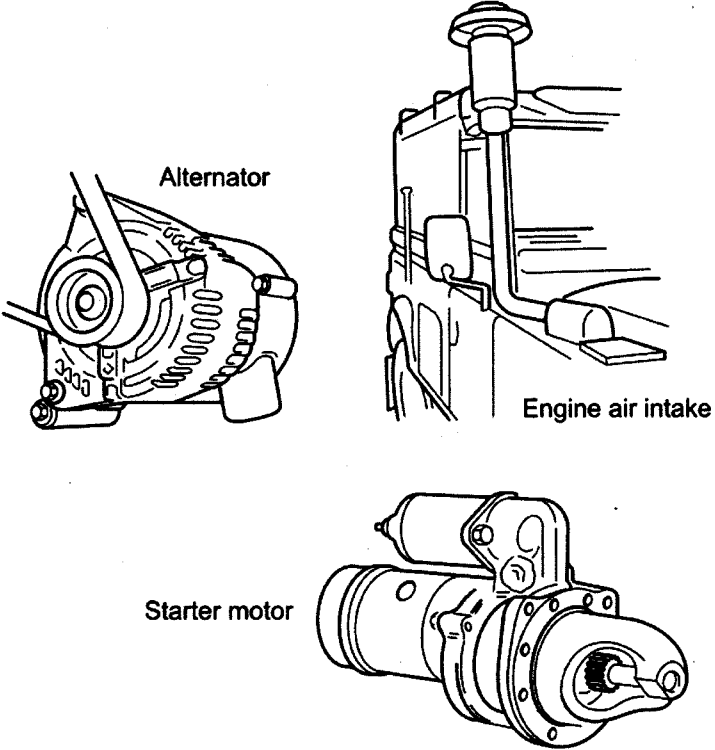
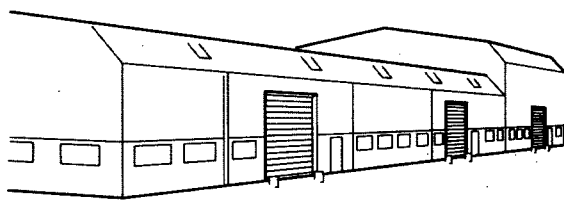
TABLE 1 SEMI-PERMANENT WATERPROOFING EQUIPMENT MARKINGS

Serial (1)	Colour meaning (2)		Action (3)
1	 Blue with white 'A' in centre	SEMI-PERMANENT Stage 'A' completed (build standard modifications)	Production build standard or Unit Workshops
2	 Red with white 'B' in centre	SEMI-PERMANENT Stage 'A' checked Stage 'B' Completed Equipment passed for disembarkation	Assembly area, onboard Landing Ship or embarkation area

NOTE

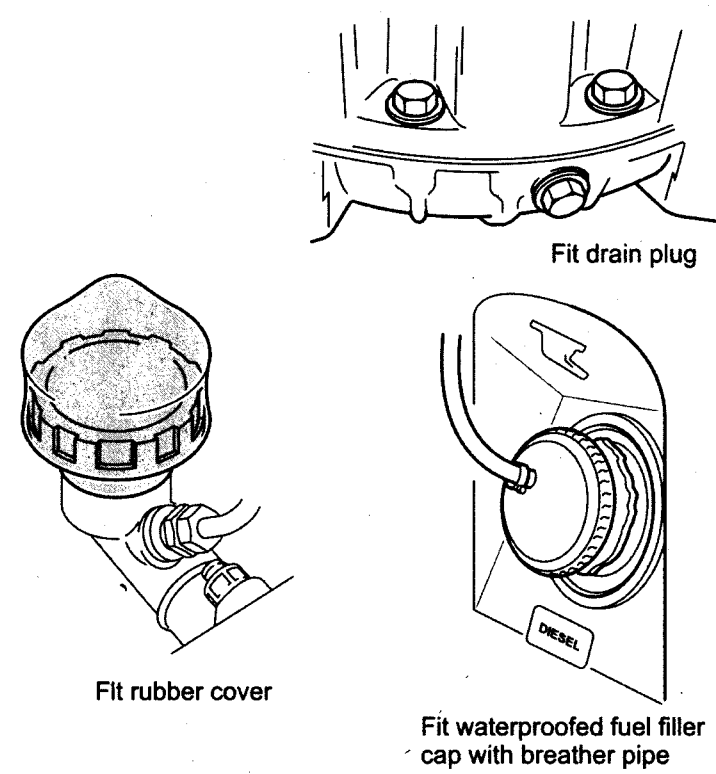
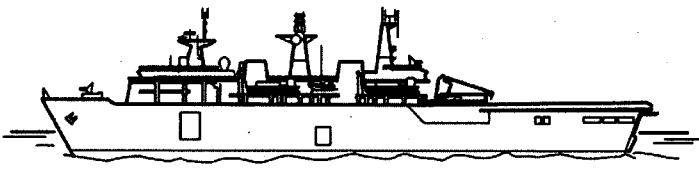
The stage 'B' marking must be covered with black adhesive tape when stage 'C' or 'D' has been completed. The marking must be uncovered when stage 'B' is complete for further fording operations.

TABLE 2 SEMI-PERMANENT WATERPROOFING STAGES (A-D)

Serial (1)	Stage (2)	Build standard or stage 'A' waterproofing kit (3)
1	Subsequent permissible mileage	No restriction on mileage
2	Stage times (comparative)	Days
3	Sample of components to be dealt with at each stage	 <p>Alternator</p> <p>Engine air intake</p> <p>Starter motor</p> <p>WAT-17069-013-003-01</p>
4	Where or when carried out	 <p>Production build standard or Unit workshops</p> <p>WAT-17069-013-016-01</p>

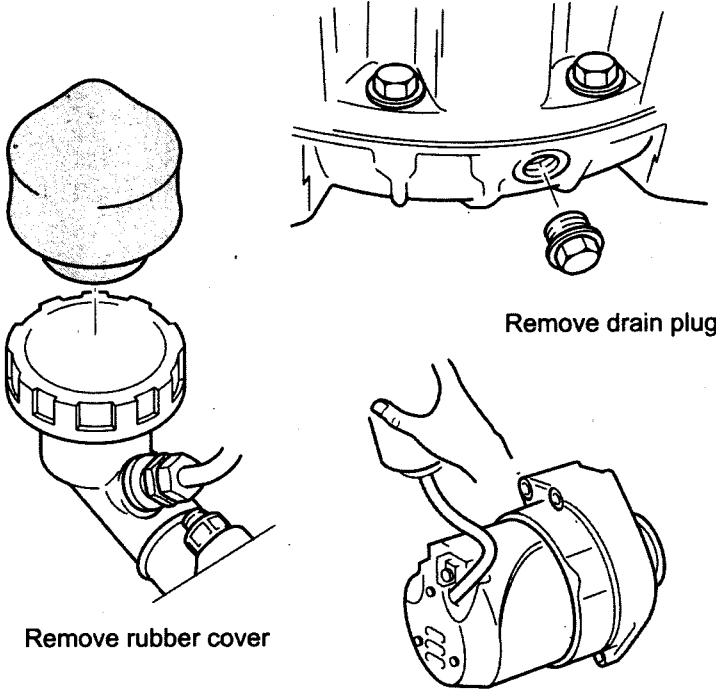

(continued)

TABLE 2 STAGE B - SEMI-PERMANENT (continued)

Serial (1)	Stage (2)	Stage 'B' waterproofing (3)
5	Subsequent permissible mileage	Pre-ford running time restricted to 15 minutes
6	Stage times (comparative)	[REDACTED]
7	Sample of components to be dealt with at each stage	 <p style="text-align: center;">Fit drain plug</p> <p style="text-align: center;">Fit rubber cover</p> <p style="text-align: center;">Fit waterproofed fuel filler cap with breather pipe</p> <p style="text-align: right; font-size: small;">WAT-17069-013-004-01</p>
8	Where or when carried out	<p>Assembly area, on-board Landing Ship or embarkation area</p>  <p style="text-align: right; font-size: small;">WAT-17069-013-005-01</p>

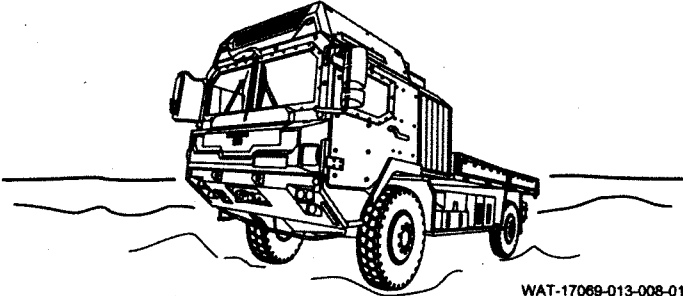
(continued)

TABLE 2 STAGE C - SEMI-PERMANENT (continued)

Serial (1)	Stage (2)	Stage 'C' de-waterproofing (3)
9	Subsequent permissible mileage	Battlefield mission of equipment
10	Stage times (comparative)	15 Minutes
11	Sample of components to be dealt with at each stage	 <p data-bbox="687 1241 938 1265">Remove rubber cover</p> <p data-bbox="1171 924 1385 949">Remove drain plug</p> <p data-bbox="1023 1330 1385 1355">Flush and re-connect alternator</p> <p data-bbox="1262 1398 1430 1415">WAT-17069-013-006-01</p>
12	Where or when carried out	<p data-bbox="603 1584 1011 1609">Within one hour of leaving the water</p>  <p data-bbox="1206 1854 1374 1871">WAT-17069-013-007-01</p>

(continued)

TABLE 2 STAGE D - SEMI-PERMANENT (continued)

Serial (1)	Stage (2)	Stage 'D' de-waterproofing (3)
13	Subsequent permissible mileage	Battlefield mission mileage.
14	Stage times (comparative)	Hours
15	Sample of components to be dealt with at each stage	Typical examples: 1. Check engine, gearbox and axle oils. Change if contaminated. 2. Wash down equipment with fresh water. 3. Full Post-ford service of equipment.
16	Where or when carried out	As soon as conditions permit before or after completion of the battlefield mission.  <p style="text-align: right; font-size: small;">WAT-17069-013-008-01</p>

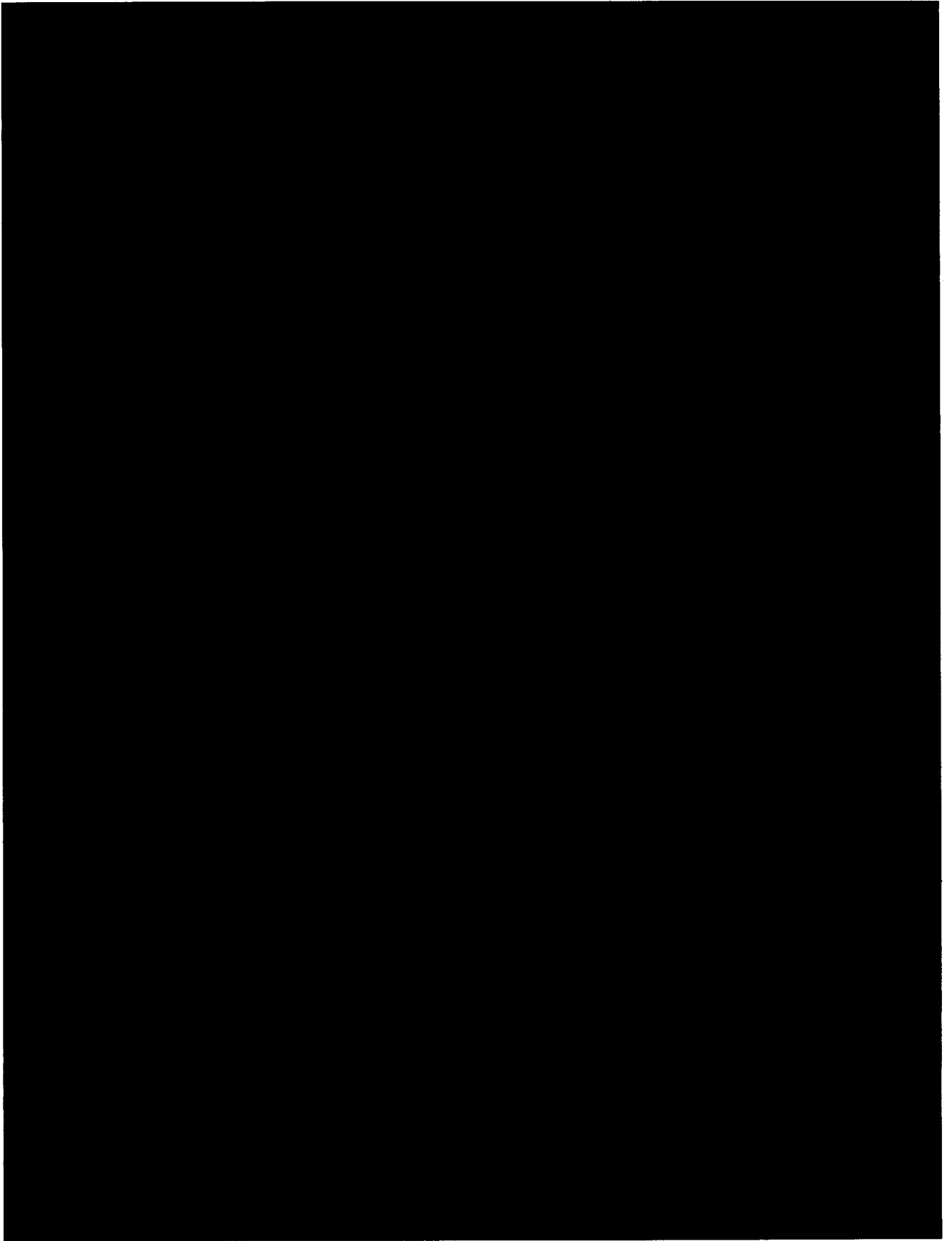


TABLE 4

Serial (1)	Designation of type (2)	Reason (3)
1		
2		
3		

TABLE 5 VEHICLES AND EQUIPMENT WATERPROOFING KITS

Serial (1)	Equipment (2)	AESP (3)	Waterproofing Kit NSN (4)	Ford depth (5)	Manpower (6)	Waterproofing Stages, Total Man-hours			
						Stage 'A' (7)	Stage 'B' (8)	Stage 'C' (9)	Stage 'D' (10)
1	Land Rover TUL/TUM (HS) GS Variant	2320-D- 128-421 Inst Instr No.1	Stage 'B' Waterproofing kit 7XDW 2540-99-573- 6345	1.5 m	Driver & VM	-	■	0.2	■
2	Land Rover TUL/TUM (HS) FFR Variant	2320-D- 128-421 Inst Instr No.2	Stage 'B' Waterproofing kit 7XDW 2540-99-573- 6346	1.5 m	Driver & VM	-	■	0.2	■
3	Land Rover TUM (HS) Battlefield Ambulance	2320-D- 128-421 Inst Instr No.3	Stage 'B' Waterproofing kit 7XDW 2540-99-481- 9231	0.6 m	Driver & VM	-	■	0.2	■
4	Pinzgauer TUM (HD) 4x4 GS Variant	2320-D- 400-421 Inst Instr No.1	Stage 'B' Waterproofing kit 7SDP 2540- 99-406-3897	1.5 m	Driver & VM	-	■	0.25	■
5	Trailer, Lightweight, GS Cargo	2330-E- 202-421 Inst Instr No.1	Stage 'B' Waterproofing kit 7LWT 2540- 99-291-1332	1.5 m	Driver	-	■	0.1	■
6	Trailer Cargo 3 Tonne GS 2 Whd Universal Engineering Ltd	2330-H- 300-201 Operatin g Informati on	Trailer is capable of Unprepared Fording to 1.5 m. Post ford maintenance is contained in "Operating information", Chapter 4.	1.5 m	Nil	■	■	Nil	■

(continued)

TABLE 5 VEHICLES AND EQUIPMENT WATERPROOFING KITS (continued)

Serial (1)	Equipment (2)	AESP (3)	Waterproofing Kit NSN (4)	Ford depth (5)	Manpower (6)	Waterproofing Stages, Total Man-hours			
						Stage 'A' (7)	Stage 'B' (8)	Stage 'C' (9)	Stage 'D' (10)
7	Gun, 105 mm, Field, L118 Towed	1015-K- 100-421 Inst Instr No.1	Stage 'A' Build Standard Annual Maintenance	0.5 m	Gun Fitter	■	-	-	-
		1015-K- 100-421 Inst Instr No.2	Stage 'B' Waterproofing Kit N1 1015- 99-344-3581	1.5 m	Gunner and Gun Fitter Class 2 Min	-	■	0.25	■
8	Truck, Load Handling (DROPS) 15 Tonne, 8x6, LHD, MMLC (Leyland Daf)	2320-R- 301-423 Wpf Instr No.1	Stage 'A' Modification Kit 6WPG 2540- 99-325-2551	0.75m	VM	■	-	-	-
		2320-R- 301-421 Wpf Instr No.1	Stage 'B' Modification Kit 7FW 2540-99- 338-8086	1.5 m	Driver & VM	-	■	0.25	■
9	Trailer, Cargo, Skeletal, Wheeled, 15 Tonne (DROPS)	2330-S- 300-423 Wpf Instr No.1	Stage 'A' Modification Kit 6WPG 2590- 99-499-7551	0.5 m	VM	■	-	-	-
		2330-S- 300-421 Wpf Instr No.1	Stage 'B' Modification Kit 6WPG 2540- 99-383-9933	1.5 m	Driver & VM	-	2.0	■	■
10	Dump Truck, Self- Loading, Medium, 6x6 Iveco Trakker AD380T45 W	3805-B- 200-201 Inst Instr No.1	Waterproofing Kit issued as (CES) Items. Fording instructions contained in "Operating Information"	1.5 m	Driver & VM	-	■	0.2	■
11	Tractor, Wheeled, Earth moving, Light, JCB 4CX	2420-G- 108-421 Inst Instr No.1	Stage 'B' Waterproofing Kit 8REBM 2540-99-886- 2331	1.5 m	Driver	-	■	0.1	■
11a	Tractor, Wheeled, Earthmovin g, light, JCB 4CX (new version)	3805-E- 128-201 ANNEX B - Appendi x 10	Waterproofing Kit issued as (CES) Items, Fording Instructions contained within "Operating Information"	1.5 m	Driver	-	■	0.1	■
12	Trailer, Field Equipment Power Supplies (FEPS)	6115-L- 100-421 Inst Instr No.1	Waterproofing Kit issued as (CES) Items.	1.5 m	Driver & VM	-	■	0.25	■

(continued)

TABLE 5 VEHICLES AND EQUIPMENT WATERPROOFING KITS (continued)

Serial (1)	Equipment (2)	AESP (3)	Waterproofing Kit NSN (4)	Ford depth (5)	Manpower (6)	Waterproofing Stages, Total Man-hours			
						Stage 'A' (7)	Stage 'B' (8)	Stage 'C' (9)	Stage 'D' (10)
13	Oshkosh Wheeled Tanker: Tractor Wheeled 6 x 6	2320-R- 320-201	Waterproofing Kit issued as (CES) Items. Fording instructions contained in "Operating information".	1.5 m	Driver & VM	-	■	0.25	■
14	Oshkosh Semi- Trailer: Close Support Tanker (CST). (Fuel)	2320-R- 321-201	Waterproofing Kit issued as (CES) Items. Fording instructions contained in "Operating information".	1.5 m	Driver & VM	-	■	0.25	■
15	Oshkosh Semi- Trailer: Tactical Aircraft Refueller (TAR)	2320-R- 321-201	Waterproofing Kit issued as (CES) Items. Fording instructions contained in "Operating information".	1.5 m	Driver & VM	-	■	0.25	■
16	MAN Support Vehicle (SV): 6 Tonne Medium Mobility- (MM) 4 x 4	2320-W- 100-421 Inst Instr No.1. All Variants.	Waterproofing kit details contained in: AESP 2320-W- 100-421 Inst Instr No.1.	1.5 m	Driver & VM	-	■	0.25	■
17	MAN Support Vehicle (SV): 9 Tonne Medium Mobility- (MM) 6 x 6	2320-W- 100-421 Inst Instr No.1. All Variants.	Waterproofing kit details contained in: AESP 2320-W- 100-421 Inst Instr No.1.	1.5 m	Driver & VM	-	■	0.25	■
	9 Tonne Improved Medium Mobility- (IMM) 6 x 6	2320-W- 100-421 Inst Instr No.1. All Variants.		1.5 m	Driver & VM	-	■	0.25	■
18	MAN Support Vehicle (SV): 15 Tonne 8 x 8	2320-W- 100-421 Inst Instr No.1. All Variants.	Waterproofing kit details contained in: AESP 2320-W- 100-421 Inst Instr No.1.	1.5 m	Driver & VM	-	■	0.25	■

(continued)

TABLE 5 VEHICLES AND EQUIPMENT WATERPROOFING KITS (continued)

Serial (1)	Equipment (2)	AESP (3)	Waterproofing Kit NSN (4)	Ford depth (5)	Manpower (6)	Waterproofing Stages, Total Man-hours			
						Stage 'A' (7)	Stage 'B' (8)	Stage 'C' (9)	Stage 'D' (10)
19	MAN Support Vehicle (SV): Unit Support Tanker-(UST) 9 Tonne Medium Mobility-(MM) 6 x 6	2320-W-100-421 Inst Instr No.2. All Variants.	Waterproofing kit details contained in: AESP 2320-W-100-421 Inst Instr No.2.	1.5 m	Driver & VM	-	■	0.25	■
20	MAN Support Vehicle (SV): Unit Support Tanker-(UST) 9 Tonne Improved Medium Mobility-(IMM) 6 x 6	2320-W-100-421 Inst Instr No.2. All Variants.	Waterproofing kit details contained in: AESP 2320-W-100-421 Inst Instr No.2.	1.5 m	Driver & VM	-	■	0.25	■
21	MAN Support Vehicle (SV): Recovery vehicle-(RV) Improved Medium Mobility-(IMM) 8 x 8	2320-W-100-421 Inst Instr No.3. All Variants.	Waterproofing kit details contained in: AESP 2320-W-100-421 Inst Instr No.3.	1.5 m	Driver & VM	-	■	0.25	■

(continued)

TABLE 5 VEHICLES AND EQUIPMENT WATERPROOFING KITS (continued)

Serial (1)	Equipment (2)	AESP (3)	Waterproofing Kit NSN (4)	Ford depth (5)	Manpower (6)	Waterproofing Stages, Total Man-hours			
						Stage 'A' (7)	Stage 'B' (8)	Stage 'C' (9)	Stage 'D' (10)
22	* Hägglunds All-Terrain Vehicle (Protected) ATV(P), Viking:								
	<u>Command Vehicle (CV)</u>	2350-T- 265-201	Waterproofing Kit issued as (CES) Items. Fording & Flotation instructions contained in "Operating information".	1.5 m	Crew	-	■	0.25	■
				1.5 m	Crew	-	■	0.25	■
				1.5 m	Crew	-	■	0.25	■
	<u>Troop Carrying Vehicle (TCV)</u>	2350-T- 265-201	Waterproofing Kit issued as (CES) Items. Fording & Flotation instructions contained in "Operating information".						
	<u>Repair & Recovery Vehicle (RRV)</u>	2350-T- 260-201	Waterproofing Kit issued as (CES) Items. Fording & Flotation instructions contained in "Operating information".						

(continued)

* NOTE

Hägglunds ATV (P) Viking is capable of Flotation (swimming) as well as Fording. Preparation and Post Ford servicing or Post Flotation servicing tasks are the same.

TABLE 5 VEHICLES AND EQUIPMENT WATERPROOFING KITS (continued)

Serial (1)	Equipment (2)	AESP (3)	Waterproofing Kit NSN (4)	Ford depth (5)	Manpower (6)	Waterproofing Stages, Total Man-hours			
						Stage 'A' (7)	Stage 'B' (8)	Stage 'C' (9)	Stage 'D' (10)
23	Hägglunds BV 206 - MAMBA	2350-T- 303-201	Waterproofing Kit issued as (CES) Items. Fording instructions contained in "Operating information".	1.5 m	Crew	-	■	0.25	■
24	Hägglunds BV 206 - TCV	2350-T- 303-201	Waterproofing Kit issued as (CES) Items. Fording instructions contained in "Operating information".	1.5 m	Crew	-	■	0.25	■
25	Hägglunds BV 206 - FFR	2350-T- 303-201	Waterproofing Kit issued as (CES) Items. Fording instructions contained in "Operating information".	1.5 m	Crew	-	■	0.25	■
26	Hägglunds BV 206 - Javelin HVM	2350-T- 303-201	Waterproofing Kit issued as (CES) Items. Fording instructions contained in "Operating information".	1.5 m	Crew	-	■	0.25	■
27	Hägglunds BV 206 - Mortar	2350-T- 303-201	Waterproofing Kit issued as (CES) Items. Fording instructions contained in "Operating information".	1.5 m	Crew	-	■	0.25	■
28	Hägglunds BV 206 - FRT	2350-T- 303-201	Waterproofing Kit issued as (CES) Items. Fording instructions contained in "Operating information".	1.5 m	Crew	-	■	0.25	■
29	Hägglunds BV 206 - Flat bed	2350-T- 303-201	Waterproofing Kit issued as (CES) Items. Fording instructions contained in "Operating information".	1.5 m	Crew	-	■	0.25	■
30	Terrier Armoured Engineer Tractor Full Tracked	-	Waterproofing Kit in Development/pr oduction	1.5 m	Crew	-	■	TBC	■

PAGE LEFT INTENTIONALLY BLANK

CHAPTER 2

WATERPROOFING MATERIALS AND THEIR USAGE

CONTENTS

Para

	Introduction
1	Health and Safety
2	Scope
3	Army Equipment Support Publications
5	Waterproofing Kits
7	General Instructions
	Materials, uses and application (WARNING)
12	Solvent Cleaner (6850-99-192-3265)
13	Bostik 1GA 186 adhesive (8040-99-224-5034)
14	Sealing compound (8030-99-517-8487)
17	Sealing compound application
20	Sealant, industrial, 3Ms, EC-750-C (8030-99-224-5433)
21	Spray sealer, 3Ms, Scotch 1602 (5970-99-224-4974)
22	Tape, adhesive, 3Ms, Scotch 88 all-weather PVC tape (5970-99-664-8764)
23	Covers, elastic, waterproofing
25	Rubber non-return valves
26	Cover, battery vent (2540-99-815-9287)
27	Compound silicone (5970-99-225-1703)
28	Solution, temporary protective PX-24 (6850-99-224-5311)
29	Grease, PX-7 (9150-99-943-2033)
30	Grease, XG-279 (9150-99-220-2418)
31	Grease, XG-286 (9150-99-224-8885)
32	Bags, waterproofing, cargo
33	PVC Cargo bag, closure slider
34	Examples of the use of bags, waterproofing
36	Bag, envelope, PVC
38	Training in the use of waterproofing materials
39	3 Cdo Bde RM waterproofing
40	RM/REME controlled waterproofing
41	Materials for training
42	Suitability of waterproofing kits
44	Maintenance of stage 'A' waterproofing
45	Issue of stage 'B' waterproofing kits
46	NATO 6TN Battery waterproofing (WARNING)

Fig

Page

1	Method of application.....	4
2	Application of sealing compound.....	4
3	Seals and slider of PVC cargo bags.....	6
4	Standard method of waterproofing NATO 6TN batteries.....	10

INTRODUCTION

Health and Safety

1 The materials and substances used in waterproofing kits are required to meet obligations introduced under the Control of Substances Hazardous to Health Regulations 2004 (COSHH). Safety information relating to materials used is contained in (JSP 515) Hazardous Stores Information System 2 (HSIS 2).

Scope

2 This Publication only applies to waterproofing kits for prepared fording.

Army Equipment Support Publications

3 Waterproofing AESPs published are listed in Chap 1, Table 5 of this publication together with the corresponding NATO Stock Numbers (NSNs) of waterproofing kits. It is the responsibility of the Unit MTO/QM (Tech) to ensure that all AESPs are up to date at current edition. Refer to Design Repository Technical Documentation on Line (DR TDOL).

4 Details are given of the materials provided in these kits, together with instructions for the method and purpose of their application for installation.

Waterproofing Kits

5 A waterproofing kit contains material, and parts, sufficient to waterproof one particular equipment. The kit will only suit that equipment and variations in make, model or mark of the equipment usually necessitate different kits.

6 Usually kits are packed to ensure a minimum storage life of two years from the date of packing. Subsequently, after inspection and repair where necessary, the kits may be fit for storage for a further two years. The date of original packing and subsequent inspections should therefore be marked on the inspected package. Provided that the kit is within two years of its last inspection and that the case is undamaged on receipt, the kit should be serviceable. Nevertheless, before use the Unit must thoroughly check to ensure completeness and serviceability of the kit and to ensure that the kit corresponds with the equipment to be waterproofed.

NOTE

Inflammable items and compounds which have a shelf storage life are not supplied with the waterproofing kits. These items are listed in the AESP kit list and are to be demanded separately by Units prior to undertaking the fitting of waterproofing kits.

GENERAL INSTRUCTIONS

7 Waterproofing is carried out in stages and each stage must be completed in the sequence given in the instruction (AESP). The tasks within each stage are given in the sequence most suited, but this may be varied according to circumstances. Where complete task coverage requires more than one page the task must be read in its entirety before commencing a page by page progression.

8 **CLEANLINESS IS THE FIRST ESSENTIAL OF SUCCESSFUL SEALING.** When applying sealants, ensure that the hands are clean and free from grease and that all surfaces to which sealing compounds are to be applied are scrupulously clean. Mud, oil, grease or water will spoil adhesion.

9 **REMEMBER THAT ALL WATERPROOFING MUST BE 100 PER CENT SUCCESSFUL.** One carelessly treated component may cause failure at a critical moment, so care must be taken with every detail. Whenever waterproofing is being carried out during wet weather suitable shelter should be arranged over the vehicle.

10 Vehicle loads must be made secure to prevent any movement whilst vehicles are ascending or descending the ramp of the ship or craft.

- 11 If difficulties are encountered, the senior attachment ES Officer should be consulted.

MATERIALS, USES AND APPLICATION

WARNING

HEALTH AND SAFETY. MATERIALS USED IN WATERPROOFING ARE REQUIRED TO MEET OBLIGATIONS INTRODUCED UNDER THE CONTROL OF SUBSTANCES HAZARDOUS TO HEALTH REGULATIONS (COSHH). SAFETY INFORMATION RELATING TO MATERIALS USED IS CONTAINED IN JSP 515- HAZARDOUS STORES INFORMATION SYSTEM 2 (HSIS 2).

Solvent Cleaner (6850-99-192-3265)

- 12 This is used for cleaning and degreasing surfaces before applying Waterproofing Materials. Solvent cleaner is a flammable liquid. Suitable precautions should therefore be taken.

Bostik 1GA 186 adhesive (8040-99-224-5034)

- 13 This is a medium viscosity adhesive, buff coloured, with high bond strength and resistant to heat. It can be easily applied by brushing and is particularly suited for the adhesion of fabrics to metal, adhesion of natural and neoprene rubber and Polyvinyl Chloride (PVC) materials. Bostik Cleaner No 6012 should also be used to clean metal surfaces before applying the adhesive.

Sealing compound (8030-99-517-8487)

- 14 A plastic sealing compound for waterproofing, which when moulded around or over a component prevents water entry. Component surfaces must be cleaned with solvent cleaner and be free from oil and dirt. Oil adversely affects the sealing compound which becomes soggy when contaminated with lubricants or fuel oils. Adhesion is poor on damp surfaces; these must be both thoroughly clean and dry to ensure that the sealing compound adheres correctly. Sealing compound does not harden on ageing and retains its tackiness and is not affected by normal engine temperatures.

- 15 Sealing compound is manufactured and issued in strips 600 mm (24 in.) long by 40 mm (1½ in.) wide by 3mm (⅛ in.) thick. These are enclosed between a backing release paper and a top centre perforated release paper. The whole is enclosed within a sealed polythene bag.

- 16 The insulating properties of the sealing compound make it suitable for waterproofing electrical components. Fig 1 illustrates the method of handling.

NOTES

- (1) Sealing compound must never be applied to any metal surface which has not been thoroughly cleaned and dried.
- (2) Always keep sealing compound clean and dry. The biggest hindrances to successful waterproofing are **OIL, DIRT** and **WATER**; therefore cleanliness is a major factor towards successful waterproofing.

Sealing compound application

17 Fig 1 illustrates the method of application. Lay the strip on a clean surface, tear open the outer polythene envelope wrapping at one end and slide out the sealing compound strip.

18 Remove the plain backing paper. Inspect sealing compound. Sections showing signs of dryness or cracks must be removed by cutting out suspected section of the strip.

19 Cut off the required length for use.

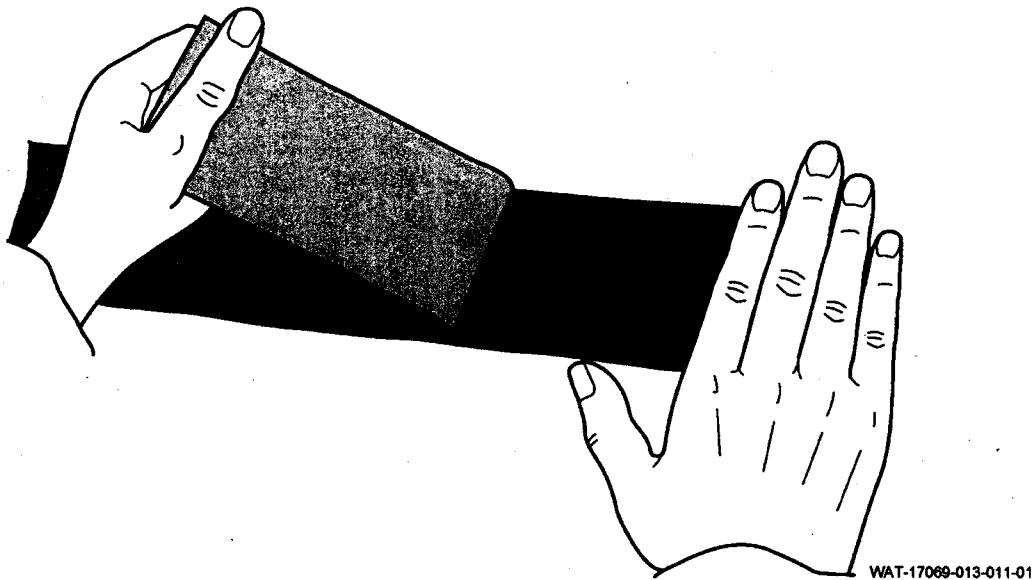


Fig 1 Method of application

NOTE

Remove the remaining backing paper on the job.

<u>APPLYING SEALING COMPOUND TO AN UNEVEN SURFACE</u>	<u>JOINING STRIPS OF SEALING COMPOUND</u>
Using fingers mould well down around uneven surfaces making sure no air pockets remain beneath the sealing compound.	Always overlap like this and using fingers, lightly mould joint together.
<p>A diagram showing a strip of sealing compound being applied to an uneven surface. The strip is being pressed down by a finger. A small cylinder and a circle are shown on the surface to illustrate the unevenness. A reference code 'WAT-17069-013-012-01' is at the bottom right.</p>	<p>A diagram showing two strips of sealing compound overlapping. The overlapping area is shaded. A dimension line indicates a 6mm overlap. A reference code 'WAT-17061-013-013-01' is at the bottom right.</p>

Fig 2 Application of sealing compound

Sealant, industrial, 3Ms, EC-750-C (8030-99-224-5433)

20 Supplied in 4 oz tubes, 3Ms EC-750-C is a sealant which dries to form a tough flexible seal. Designed primarily to accommodate movement in ducting and other sheet metal or fabric fabrications it is used for the potting of multi-pin electrical plugs and sockets and for sealing cables and cable ducting. The material is fuel and oil resistant.

Spray sealer, 3Ms, Scotch 1602 (5970-99-224-4974)

21 An electrical grade sealer and insulator for spraying on alternator windings and electrical connections. Protects a variety of surfaces against moisture, corrosion, oils, alkalis and acids.

Tape, adhesive, 3Ms, Scotch 88 all-weather PVC tape (5970-99-664-8764)

22 A waterproof adhesive tape, suitable for repairing and sealing PVC bags, breathers, apertures, joints and components. The width of the tape can be increased by over-lapping to the required width.

Covers, elastic, waterproofing

23 These covers are manufactured from neoprene rubber and are resistant to fuel and lubricant oils. They are capable of withstanding normal engine temperatures, but are inclined to harden in low temperatures of -30° C. Pre-heating or immersion of rubber covers in hot water will make them more flexible for application.

24 Operators should not attempt to fit covers with long or jagged finger nails as either may cause minor tears which extend when the covers are in a stretch fit condition. Minor tears can be repaired temporarily with adhesive tape. Repaired covers should be replaced as soon as conditions permit.

Rubber non-return valves

25 These are simple pressure activated valves made from thin rubber tube. Their main use is to close up engine, gearbox and axle breathers when immersed, but to avoid excessive build-up of pressures during dry shod running.

Cover, battery vent (2540-99-815-9287)

26 These are rubber sheaths which are fitted over the cell filler caps. There is a very fine slit in the dome of the cover, which is forced open by gas pressure when the battery is being charged. During immersion, water pressure being greater than the internal pressure set up in the battery tends to flatten the vent cover which closes the slit and prevents water entry into the cell.

Compound silicone (5970-99-225-1703)

27 Supplied in 100 g tubes and incorporated in waterproofing kits for certain equipment. It is a silicone base compound, water repellent and suitable as an insulator for electrical connections which must remain operative at all times. The components should be covered with a generous, unbroken, even film of silicone compound.

Solution, temporary protective PX-24 (6850-99-224-5311)

28 Supplied in 1 litre containers in waterproofing kits, it is used as an inhibitor and as a water displacement fluid for alternators, starter motors and other electrical components during fording operations. PX-24 is also available in 5 litre containers; (8030-99-224-4966), through DSDA supply.

Grease, PX-7 (9150-99-943-2033)

29 Supplied locally, it is not included in waterproofing kits; it is used as a preservation grease to protect battery and electrical terminals.

Grease, XG-279 (9150-99-220-2418)

30 Supplied locally in 3 kg tins. It is not included in waterproofing kits; it is a general purpose lubricant for automotive applications.

Grease, XG-286 (9150-99-224-8885)

31 Supplied locally in 3 kg tins. It is not included in waterproofing kits; it is used for protection against corrosion of mechanisms submerged in sea water or subject to the washing effect of heavy seas.

Bags, waterproofing, cargo

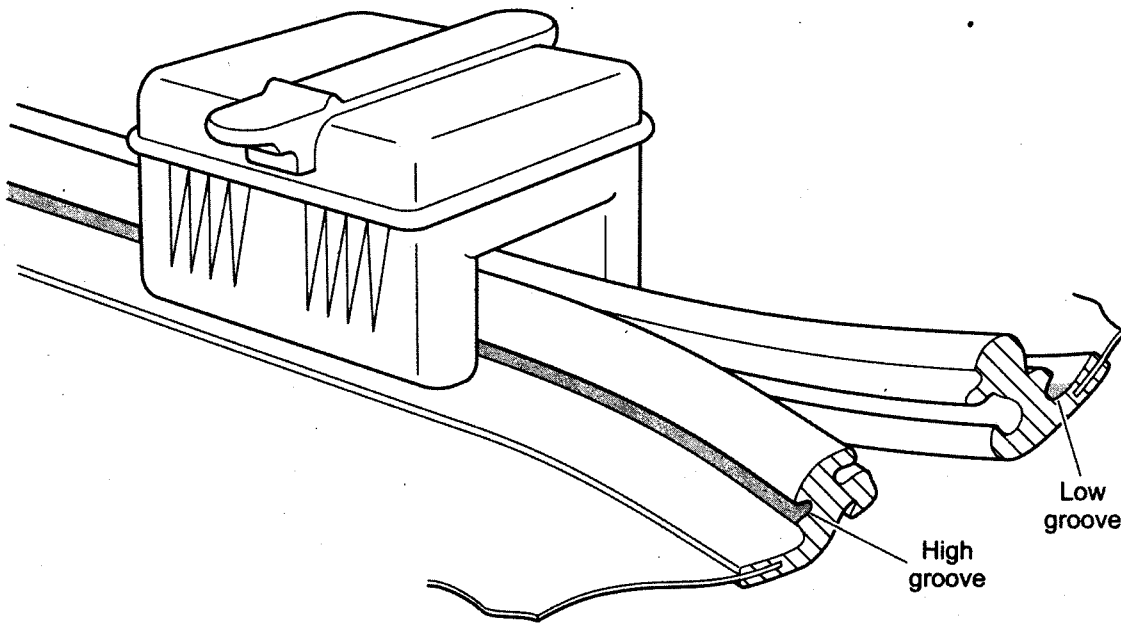
32 PVC waterproofing bags are sealed by interlocking flexible closures, details of which are shown in Fig 2. Each bag is issued with operating instructions contained in a pocket attached to the PVC bag. These bags are primarily for use with the Trailer, Lightweight GS Cargo. The smaller one can also be used for waterproofing cargo in Truck Utility Vehicles (TUV). The following two PVC bags are reusable types fitted with zip closures:

32.1 2540-99-815-9470, Bag cargo (WPG 9031). 1.8 m (72 in.) x 0.9 m (36 in.) x 0.45 m (18 in.).

32.2 2540-99-815-9471, Bag cargo (WPG 9032). 0.9 m (36 in.) x 0.9 m (36 in.) x 0.45 m (18 in.).

PVC Cargo bag, closure slider

33 Move the slider backwards and forwards until the mating faces are in contact. If the slider is stiff on the closure, apply a light film of silicone compound in the high and low grooves but **NOT** on the locking section of the closure.



WAT-17069-013-014-01

Fig 3 Seals and slider of PVC cargo bags

Examples of the use of bags, waterproofing

34 Waterproofing small optical instruments, Guided Weapon (GW) equipment, small arms ammunition and rations.

35 Waterproofing bags, which are stowed in small vehicles, e.g. Truck Utility or trailers could be completely immersed and are liable to float out. Bags should be secured to the vehicle and trailer covers should be firmly lashed down to retain the bags in the trailer body.

Bag, envelope, PVC

36 These are manufactured bags of various sizes and are used to enclose parts of the vehicle or documents as detailed in the relevant waterproofing instruction, or stowage of personal kit. The bag must be sealed with adhesive tape before any fording activity. Before use, the bag must be inspected for pin holes, tears or split seams which can be repaired with suitable lengths of adhesive tape.

37 The following sizes of PVC bags available:

37.1 8105-99-135-6190. 450 mm (17 in.) x 255 mm (10 in.)

37.2 2540-99-816-2670. 900 mm (36 in.) x 600 mm (24 in.)

Training in the use of waterproofing materials

38 The necessity of adequate training is important. Due to limitations of shipping space there will always be a shortage of vehicles in an amphibious operation. The loss of one vehicle due to failure may hold up disembarkation and have serious effects. Training of personnel in waterproofing will be divided into two categories, 3 Cdo Bde RM and RM/REME controlled.

3 Cdo Bde RM waterproofing

39 Because stage 'B' waterproofing is intended to be completed by Unit personnel with few tools, the kits are designed as simply as possible with the minimum number of special materials. It is, however, a detailed and exacting task requiring careful attention and thorough checking and supervision. The instructions are in simple language and fully illustrated in colour.

39.1 RM Drivers. Within each Unit the work must be carried out by RM drivers who are trained in waterproofing techniques by 11(ATT) Sqn, 1AGRM.

39.2 All Arms Drivers. Drivers should attend All Arms Driver waterproof training at 11(ATT) Sqn, 1AGRM. During training, it is essential that the driver should have actually waterproofed and forded at least one type of equipment.

39.3 The Waterproofing will be completed under the guidance of Unit MT/WKSP JNCOs who have been trained in waterproofing techniques by 11(ATT) Sqn, 1AGRM. The JNCO has two main tasks to perform during preparations for amphibious operations:

39.3.1 Training the drivers in material handling. Training in material handling should be carried out using the basic materials detailed in this chapter with emphasis on cleanliness, patience and conscientiousness.

39.3.2 Supervising the waterproofing of Unit equipment by checking off each task in the check list (which is printed in the last pages of the waterproofing instruction). The JNCO must be given ample time and facilities to achieve the required standard when instructing the drivers.

RM/REME controlled waterproofing

40 SO2 ES at Navy Command HQ is responsible for the attachment of a SNCO to act as an adviser to each major unit. The SNCO will be a D1/VM1 who has been specially trained in waterproofing techniques at 11(ATT) Sqn, 1AGRM:

40.1 Ideally, each RM major unit involved in amphibious operations should have a suitably trained SNCO. The SNCO will be responsible for advising the unit commander on matters relating to waterproofing of the equipment.

40.2 The SNCO must be capable of making decisions regarding waterproofing of components which may vary from those illustrated in the waterproofing instruction, due to contract changes or modification.

40.3 Training waterproofing SNCOs is the responsibility of 11(ATT) Sqn, 1AGRM. They are trained in the principles of waterproofing, de-waterproofing plus anti-corrosive treatment and post ford maintenance.

40.4 If the SNCO does not accompany the unit after the equipment has been loaded on board ship he/she will be responsible for advising the unit MTO, QM (Tech) or equivalent, on essential matters during sea transit and unit maintenance before and after fording operations.

Materials for training

41 Waterproofing material for normal training of unit personnel can be obtained in bulk through DSDA supply.

Suitability of waterproofing kits

42 To understand the procedure regarding the provision of waterproofing kits it is essential to appreciate the problem involved. A waterproofing kit is developed for particular equipment by the definition of the EAC. This covers the type, mark, make, contract number or code number.

43 MTO/QM (Tech) of the RM formation involved in an amphibious assault or exercise must ensure that the correct waterproofing kits are demanded and issued as designated in Chap 1, Table 5 Details of the waterproofing kit and EAC are given on page one of each waterproofing AESP. Units must ensure that detailed information regarding the Unit equipment is forwarded to formation HQ and on receipt of waterproofing kits, check that the correct kits have been received.

Maintenance of stage 'A' waterproofing

44 Stage 'A' waterproofing comprises the bulk of the work and is a permanent modification to the equipment. This stage of waterproofing is achieved by one of the following methods:

44.1 Build standard modification. Stage 'A' waterproofing is included within the build standard of the equipment by the manufacturer. The equipment is identified as a waterproofed variant by the EAC. Repair and maintenance is defined by the manufacturer in the relevant categories of the AESP Octad for the equipment.

44.2 Stage 'A' modification kit. Stage 'A' waterproofing of the equipment is completed by fitting a modification kit. The AESP for fitting the kit is controlled and issued by the DE&S organisation. The AESP **MUST** be retained with the MTO/QM (Tech) to assist in the maintenance and repair of the waterproofing equipment. The relevant categories of the AESP Octad for the equipment will be amended if required to cover repair/maintenance of the waterproofing modifications. When a stage 'A' waterproofing kit has been fitted for a period of twelve months, it must be inspected and maintained by a SNCO trained in the repair/maintenance of waterproofing equipment.

Issue of stage 'B' waterproofing kits

45 Stage 'B' waterproofing kits are designed where possible to be re-useable. They are to be retained with the equipment and maintained by the Unit MTO/QM (Tech). Units are to demand replacement items to replenish kits after completion of prepared fording. The kits are available to fit the following two types of modified equipment:

45.1 Production built waterproof variant. The stage 'B' kit is issued into service with this equipment by the manufacturer. It is the responsibility of the MTO/QM (Tech) to ensure that all AESP instructions issued are correct and up to date. Refer to Design Repository Technical Documentation on Line (DR TDOL). Replacement kits can be demanded from DSDA, Bicester. Demands must quote the full NATO stock number for the waterproofing kit as designated in Chap 1, Table 5.

45.2 In-service equipment modifications. The stage 'B' kits for this equipment are MOD (A) controlled stores and on operations will normally be issued as a result of Staff instruction. They can only be fitted to equipment that has been specially adapted with a stage 'A' modification kit. Should demands be authorized for training or exercises they will be demanded in the UK direct from DSDA, Bicester. Overseas they will be demanded through formation HQ. Demands must quote the full NATO stock number for the waterproofing kit as designated in Chap 1, Table 5. The authority for the demand must also be quoted.

NATO 6TN Battery waterproofing

WARNINGS

(1) **NO SMOKING OR NAKED FLAMES. LEAD ACID BATTERIES PRODUCE POTENTIALLY EXPLOSIVE GASES.**

(2) **BATTERY ACID HAZARD PROTECTION. WEAR PROTECTIVE GLOVES AND GOGGLES WHEN HANDLING BATTERY FILLER CAPS.**

46 There are two types of 6TN battery fitted to military equipment. The early types contain electrolyte acid and have rubber filler plugs. The later type are 'Gel Mat' replacements for the originals. They still retain a venting mechanism but have no filler plugs, are maintenance free and sealed for life.

47 Early type batteries. Ensure batteries are fully charged and that electrolyte level is correct.

47.1 Ensure that all battery filler plugs are pushed tightly into the filler necks.

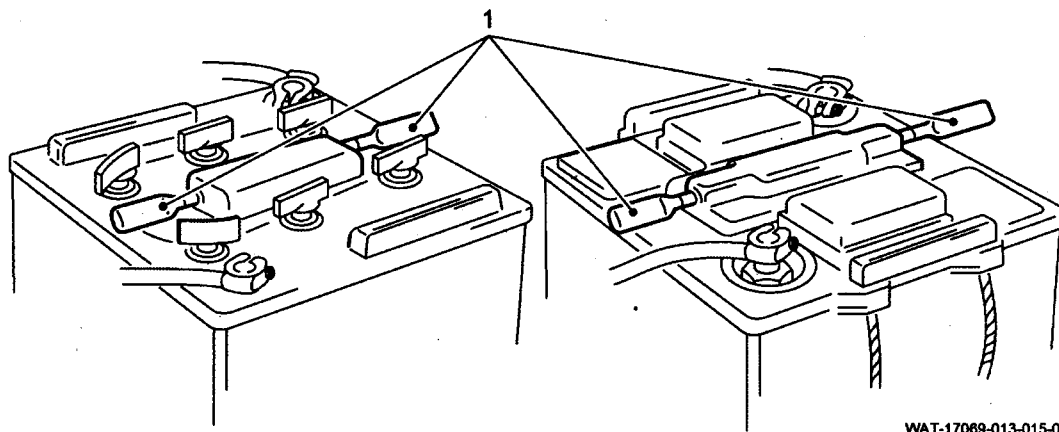
47.2 Fit a ¼ in. non-return valve over each battery vent (see Fig 4).

47.3 Brush a liberal coat of preservative grease PX-7 to all battery terminals. Refit battery covers.

48 Later type batteries. Ensure batteries are fully charged.

49 Fit a ¼ in. non-return valve over each battery vent (see Fig 4).

50 Brush a liberal coat of preservative grease PX-7 to all battery terminals. Refit battery covers.



WAT-17069-013-015-01

1 Non return valve vents

Fig 4 Standard method of waterproofing NATO 6TN batteries

CHAPTER 3

WATERPROOFING AND ITS EFFECTS ON SERVICING AND REPAIR

CONTENTS

Para

	Introduction
1	General
3	Mechanical efficiency before waterproofing
	Servicing before fording
6	Kit, waterproofing semi-permanent
7	Servicing on ship or shore when waterproofed for long periods
	De-waterproofing and servicing after fording (WARNING)
8	Operational duty
10	Temporary halt procedure
11	Vehicle parks
12	After fording training exercises
13	Servicing/repair of equipment for unprepared fording
14	Effect of modifications on waterproofing
16	Summary

INTRODUCTION

General

1 All equipment to be forded must be in a fully serviceable condition. It is a complete waste of time, effort and materials if an equipment, when forded, breaks down due to a mechanical or electrical defect which ought to have been rectified prior to waterproofing. The object of this publication is to detail the procedure to avoid such an occurrence.

2 After equipment has been forded, steps must be taken to ensure that corrosion, due to immersion in either fresh or sea water does not have a serious effect on the useful life of the equipment. This publication serves as a guide to achieve this objective.

Mechanical efficiency before waterproofing

3 Preferably vehicles selected for waterproofing should be in a fully serviceable condition. Outstanding repairs and modifications must be completed. Check the following:

- 3.1 There are no oil leaks.
- 3.2 All fuel pipe unions are tight and do not leak.
- 3.3 Worn or damaged tyres are replaced.
- 3.4 Exhaust/inlet manifolds must be checked for tightness.
- 3.5 Check for unofficial modification.

4 Where excessive repairs are required to bring the equipment up to the desired standard the equipment should be replaced. The replacement equipment should have the same Equipment Asset Code (EAC) and be identical by mark, type and contract number otherwise the waterproofing kit may not fit.

5 After the equipment has passed inspection, it must be fully serviced, washed down and cleaned with emphasis on removing surplus oil on the engine and associated components. Batteries must be fully charged and topped up. Areas of loose paint must be removed by scraping or by means of a wire brush. Repaint surfaces where time permits.

SERVICING BEFORE FORDING

Kit, waterproofing semi-permanent

6 Semi-permanent waterproofing kits employ durable mechanical waterproofing techniques. Vehicles fitted with these kits can be serviced normally and there are no mileage restrictions. Waterproofing is carried out in two stages as follows:

6.1 Stage 'A' waterproofing. Approximately 90% of waterproofing is completed at this stage which is either 'build standard' modifications or the fitting of a modification kit. This entails considerable technical support. Once completed, vehicles can operate in normal circumstances. The stage 'A' waterproofing will be inspected annually by a SNCO trained in the repair/maintenance of waterproofing equipment. Suspect waterproofing aids will be replaced or in extreme cases, a complete new kit will be fitted. Care must be taken to replace any waterproofing disturbed during workshop repairs.

6.2 Stage 'B' waterproofing. This stage is completed to enable the vehicle to ford across beaches. When stage 'B' is completed servicing is still possible but it is normally more convenient to complete the servicing before waterproofing stage 'B'.

Servicing on ship or shore when waterproofed for long periods

7 The operational plan may call for equipment which is waterproofed up to stage 'B' to be held for a long period before embarking. Alternatively, the operation may involve a long sea voyage (over 3 days at sea). Equipment must, therefore, be subject to routine inspections during this storage period. Attention must be given to the following points:

7.1 Thoroughly check all waterproofing tasks carried out in the previous stage to ensure that nothing has been damaged or displaced.

7.2 Check that oil or fuel leaks have not occurred.

7.3 Engines should be run for short periods only, so as to conserve fuel.

7.4 Batteries should be checked for 'full' charge. On board ship, slave charging can be carried out using the ship's facilities and care should be taken to ensure that charging rate is not excessive in order to avoid heavy gassing and loss of electrolyte. Battery vent covers must not be damaged.

DE-WATERPROOFING AND SERVICING AFTER FORDING

WARNING

DEFECT REPORTING. ALL DEFECTS INCLUDING OCCURRENCES OF WATER INGRESS FOUND DURING STAGE 'C' AND STAGE 'D' DE-WATERPROOFING, MUST BE REPORTED TO A SENIOR MEMBER OF UNIT ES STAFF AS SOON AS OPERATIONALLY POSSIBLE, FOR APPROPRIATE EQUIPMENT FAILURE REPORT (EFR) ACTION.

Operational duty

8 Because of varying conditions which will prevail on operational duty, it is impossible to lay down a rigid procedure for servicing after fording, but there are certain de-waterproofing tasks which must be carried out without delay. These vary for each equipment and are listed in the appropriate waterproofing AESP for the equipment. Semi-permanent de-waterproofing is broken down into two stages as follows:

8.1 Stage 'C' de-waterproofing. These are the tasks which **MUST** be carried out as soon as possible after fording. Stage 'C' de-waterproofing tasks should take no longer than 15 minutes to complete. It is permissible for the equipment to drive for one hour from the landing area before this stage is completed. After stage 'C' de-waterproofing, the equipment is capable of completing its battlefield mission. The equipment can re-ford by completing 'wet shod re-embarkation' instructions contained within the AESP.

8.2 Stage 'D' de-waterproofing. Tasks which are completed at this stage depend on whether the vehicle is to remain and operate on shore indefinitely or re-embark within a few days. The remaining tasks should be completed as soon as conditions permit before or after completion of battlefield mission. After stage 'D' is completed, the vehicle is capable of re-fording by repeating the fitting of a stage 'B' waterproofing kit.

NOTE

On completion of stage 'D' the equipment is now returned to stage 'A' and can resume normal duties.

9 As stated above, the work in stage 'C' and stage 'D' will vary for each equipment, but to generalise, tasks are as follows:

- 9.1 Open all breathers and drain holes (stage 'C').
- 9.2 Flush out electrical components as required.
- 9.3 Check all oils. If the water is contaminated, drain and refill (stage 'C' or stage 'D').
- 9.4 As soon as is practicable, wash down the equipment thoroughly with fresh water. Remove all traces of sand and salt deposits (stage 'D').
- 9.5 Carry out a post-ford service and lubrication of the equipment as detailed in the Stage 'D' de-waterproofing and in accordance with the equipment Servicing Schedule.
- 9.6 Frequent exercise of the clutch mechanism is recommended. If water has entered the clutch housing, disengage the clutch pedal with a suitable prop when leaving the equipment parked until the clutch linings and linkage have had sufficient time to dry out.
- 9.7 Brake linings should be dried out as soon as possible after landing by application of the brakes whilst on the move. Do not park equipment with brakes on unless absolutely necessary, rather chock road wheels and leave handbrake off.

Temporary halt procedure

10 On completion of de-waterproofing stage 'C', a temporary halt procedure may be necessary and the following precautions must be actioned:

- 10.1 Chock road wheels.
- 10.2 Leave the parking brake in the 'OFF' position.
- 10.3 Turn the battery isolating switch 'OFF' or disconnect the batteries.

Vehicle parks

11 On completion of fording it may be necessary to store equipment in vehicle parks and the following tasks must be carried out in addition to those listed in Para 8.2.

- 11.1 All items, such as brake servo mechanism, starter motors, generators etc., in which there is evidence of water entry must be dismantled and cleaned.

- 11.2 Wheel bearings which are not of waterproofed pattern must be dismantled, cleaned and repacked with grease.
- 11.3 Rubber gaiters fitted over tracta joints must be unclipped and if there is any evidence of water entry the tracta joints should be flushed with de-watering fluid, cleaned and oil sprayed before the rubber covers are replaced.
- 11.4 Brake and clutch mechanism must be exercised daily to maintain complete free movement.
- 11.5 Turn the battery isolating switch 'OFF' or disconnect the batteries.

After fording training exercises

12 A similar procedure to that outlined must be followed; but since time will be available, all the stage 'B' waterproofing materials must be removed. Care must be taken to ensure that no damage is done to any electrical connections or wiring harness. A thorough inspection must be made for any signs of water entry and if any is apparent, the assembly must be dismantled, cleaned and treated with PX-24 water displacement fluid. Electrical components, if saturated, must be washed with fresh water or PX-24 and dried out. Hubs and brakes should be dismantled and serviced at the earliest opportunity to reduce long-term effects of salt water corrosion.

Servicing/repair of equipment for unprepared fording

13 Special care must be taken for the servicing/repair of equipment with built-in waterproofing. **CORRECT REPLACEMENT PARTS DESIGNATED FOR THE WATERPROOFED EQUIPMENT MUST BE FITTED.** If seals and gaskets are disturbed; new seals and gaskets must be fitted and treated with the correct type of jointing compound. When assemblies or sub-assemblies are dismantled for repair, they must be refitted in accordance with the relevant AESP repair instructions for the equipment. All maintenance inspections for waterproofed equipment must be recorded in the vehicle/equipment documents.

Effect of modifications on waterproofing

14 Authorised modifications do not normally impair waterproofing as the relevant waterproofing instructions are suitably amended. Difficulty will arise when **UNAUTHORISED MODIFICATIONS** have been carried out. Equipments which are selected for operations involving fording must be inspected to ensure that no such modifications exist.

15 If it should prove essential to use a piece of equipment on an operation, which has been the subject of an unauthorised modification, the user must not attempt to improvise a waterproofing technique to cover this. A waterproofing SNCO trained in the repair/maintenance of waterproofing equipment must be consulted for advice.

Summary

16 As stated in Para 8 and 9, de-waterproofing and servicing tasks vary for each type of equipment and the foregoing is only a guide. The detailed work for every equipment which can be forded is contained in the respective waterproofing instruction.

17 When a formation is taking part in an amphibious operation, the load on ES personnel will undoubtedly increase because, in addition to waterproofing their own equipment, ES personnel will have to assist their dependent units. Consequently, it will probably be necessary to call in outside assistance, either to carry out the inspection of equipment or to assist in the waterproofing effort.

CHAPTER 4

DRIVING OF WATERPROOFED EQUIPMENT AND BEACH RECOVERY

CONTENTS

Para

- 1 Introduction
Driving waterproofed equipment on land before fording
- 3 Kit, waterproofing, semi-permanent
Driving during fording (CAUTION)
- 4 Beach gradient
Driver responsibilities
- 5 Driving of fording vehicles
Co-driver responsibilities
- 12 Co-Driver primary duties
- 13 Co-Driver secondary duties
Driving across beaches and after fording
- 14 Post ford driving
Driver training for fording operations
- 22 Training
- 25 Beach recovery and drowned vehicle park

INTRODUCTION

1 In an amphibious operation, vehicles will usually be carried in landing craft and discharged direct from these craft probably through a water gap on to the beaches beyond. Before and after loading into landing craft, vehicles pass through several stages of waterproofing. They are then ready to carry out their battlefield-mission after the beach landing. Waterproofing and other operations are as follows:

- 1.1 Preparation servicing and inspection of stage 'A' waterproofing in unit lines. Then movement to the loading areas.
- 1.2 Waterproofing loading areas. Stage 'B' waterproofing may be carried out here, on a Landing Platform Dock (LPD) or on a Landing Ship Dock (LSD) during a sea voyage.
- 1.3 Amphibious landing, where the fording of the water gap is carried out crossing the assault beach.
- 1.4 Completion of stage 'C' de-waterproofing, after which the equipment battlefield mission can be carried out.
- 1.5 Completion of stage 'D' de-waterproofing and equipment post-ford servicing.

2 Conditions will vary for each operation. The maximum number of vehicles will be required as early as possible after the initial assault, and the successful landing of serviceable vehicles will depend to a great extent on the experience and stage of training of each driver.

DRIVING WATERPROOFED EQUIPMENT ON LAND BEFORE FORDING

Kit, waterproofing, semi-permanent

3 Letters are used to describe the various stages of waterproofing. The application of semi-permanent waterproofing is broken down into two stages:

3.1 Stage 'A'. This is the initial fitting of most of the waterproofing items including the bulk of the VM work. This stage may be completed at the production build standard of the equipment by the manufacturer or by fitting a stage 'A' modification kit any time during the normal life of the equipment. There is no restriction on mileage that the equipment may cover after this stage has been completed.

3.2 Stage 'B'. These are the final tasks before fording. [REDACTED]

[REDACTED]. After Stage 'B' has been completed, pre-ford running time should be restricted to 15 minutes and a final check on the waterproofing before disembarkation is essential.

DRIVING DURING FORDING

CAUTION

ENGINE DAMAGE. IF THE VEHICLE FAILS DUE TO ENGINE STOPPAGE, ENGAGE NEUTRAL AND DO NOT ATTEMPT TO RE-START. WATER MAY HAVE ENTERED THE ENGINE BY THE EXHAUST PIPE AND CAUSED A HYDROSTATIC LOCK. USE OF THE STARTER MOTOR COULD HAVE CATASTROPHIC RESULTS.

Beach gradient

4 The landing craft is trimmed to the gradient of the beach prior to landing to prevent grounding by the stern when retracting. On a steep beach the landing will be dry but on a flat beach it will be wet and vehicles may have to drive off into any depth up to 1.5 m of water including ramp angle, wheel sink and wave height.

DRIVER RESPONSIBILITIES

Driving of fording vehicles

5 Drivers must be trained and practiced in driving through water in order to get the feel of their vehicles under these conditions. They should be practiced in driving down steep slopes into water, so that the essential experience, skill and confidence can be gained to drive a vehicle down a landing craft ramp into the sea. This type of training also covers driving down a river bank, which can be considered in the light of a landing craft ramp. It is at the moment of entering the water that most cases of 'drowning' occur and this can generally be traced to inexperienced driving.

6 Fording in deep water bears little relationship to normal driving. Once immersed, the engine and transmission can become relatively silent and forgotten. The vehicle appears slow to respond to the wheel, hence there is a tendency for the beginner to over-steer. With waves following the vehicle or when landing on a falling tide, the driver may have doubts about his forward motion, but a quick check against objects on the far shore will be reassuring.

7 Driving instructions for prepared fording are contained in the waterproofing instruction for each vehicle. When fording with normal GS vehicles, bottom gear low ratio is most suitable; but for some specialised equipment, this gear may be too low. [REDACTED]

[REDACTED] Ensure before leaving the landing craft that all-wheel drive is engaged. Rear axle differential locks if fitted may be required to be engaged. To prevent flotation of some vehicles, the waterproofing instruction calls for the cab doors, tailboard or rear door to be propped open. This ensures rapid flooding of the vehicle body. Drive slowly down the ramp ensuring that the approach is 'square' so that the minimum amount of steering is required when the vehicle is actually on the ramp. On entering the water, depress the accelerator and maintain a steady speed until the beach exit or firm ground is reached. Some wet sand can be very soft and wheel spin may occur when the rear wheels touch the ground.

8 In the water the driver must keep his foot down on the accelerator, and ensure that it does not slip off, as there is a tendency for the leg to rise when the cab of the vehicle fills with water. If a hand throttle or throttle stop screw is fitted it should be so adjusted that should the driver's foot slip off the accelerator, the engine will not 'die'. Except for fully tracked vehicles, the clutch must on no account be used while the vehicle is moving down the ramp or in the water. Do not attempt to change gear in any type of 'B' or 'C' vehicle.

9 Drivers must ensure before leaving the landing craft, that a suitable towrope equipped with a throwing line is fitted to the front end of their vehicle. It should be readily accessible to the co-driver. If for any reason the vehicle fails in the water, the co-driver will hold the towrope ready for immediate coupling to the recovery vehicle. Gun detachments must be ready to manhandle their equipment, and will carry drag-ropes for this purpose. Every effort must be made to prevent a 'drowned' vehicle/equipment blocking the way of the next vehicle leaving the landing craft.

10 If the equipment 'bogs down' and engine stalling can be avoided, engage neutral and keep the engine running at a fast tick-over and wait for recovery. Drivers must remember that if their vehicle fails in the water and is impeding the flow of traffic, it may be pushed or towed out of the way and not immediately recovered to the beach. The all-important aim is to get as many vehicles ashore in fighting condition in the shortest possible time.

CO-DRIVER RESPONSIBILITIES

11 The Co-driver has a key role to play when fording 'B' type vehicles from ship to shore and back to the ship. When a vehicle is prepared for fording the co-driver is to make a final check that the recovery rope is fitted correctly and is ready to deploy if the vehicle should become a casualty when crossing the water gap.

Co-Driver primary duties

12 The co-driver primary duties are:

12.1 If the vehicle "drowns" or becomes "bogged down" during daylight hours the co-driver is to signal the Beach Recovery Vehicle (BRV) by use of hand signals that the vehicle requires recovery.

12.2 During dark hours the co-driver is to be in possession of [REDACTED] signaling the BRV that the vehicle requires recovery.

12.3 The driver is required to remain in control of the vehicle. The co-driver has sole responsibility for preparing the recovery rope for transfer to the BRV and passing by signal to the BRV that the vehicle is ready to be recovered.

12.4 He is the primary communication link between the BRV and the driver of the vehicle.

Co-Driver secondary duties

13 The co-driver secondary duties are:

13.1 The co-driver is to assume the role of "look out" for potential dangers when crossing the water gap from ship to shore and passing this information to the driver.

13.2 The co-driver is to be the "safety person" should the driver become snagged at any time when evacuation from the vehicle may be required.

13.3 The co-driver is to ensure that both he and the driver are suitably equipped and have the Vehicle Crew Lifejackets (VCLJ) fitted correctly.

DRIVING ACROSS BEACHES AND AFTER FORDING**Post ford driving**

14 Once the beach has been reached, drivers must not stop at the water's edge. They should drive straight across the beach as directed, through the exits to the beach transit areas.

15 Drivers should not normally change gear on a beach until the beach roadway is reached. By changing gear, engine speed may be reduced, causing loss of momentum and consequent bogging of the vehicle, or causing a badly running engine to stop altogether. It is, however, permissible to change gear in the following circumstances:

15.1 On long firm beaches where there is little or no danger of the vehicle sticking, and to avoid unnecessary overheating of the engine.

15.2 On hard stony beaches which are negotiated more easily in second gear.

15.3 On beaches where a higher vehicle speed is required in order to cross strips of soft sand.

16 After leaving the water, brakes will be ineffective until the components have dried. Brakes should be applied for short distances while moving, to dry them out thoroughly. Until the brakes are dry, drivers must keep a greater safety distance than usual from vehicles in front. If a vehicle is left with the brakes wet, brake seizure may occur due to the action of salt water.

17 On reaching the beach transit area, de-waterproofing stage 'C' tasks should take no longer than 15 minutes to complete. It is permissible for the equipment to drive for one hour from the landing area before this stage is completed. After stage 'C' de-waterproofing, the equipment is capable of completing its battlefield mission.

18 Certain stage 'D' de-waterproofing tasks may need to be completed within 40 km (25 miles) from the point of disembarkation, if operationally possible. Stage 'D' tasks should be completed as soon as conditions permit before or after completion of the battlefield mission.

19 The surfaces of different beaches can vary considerably and drivers should be able to recognise the various types in order to use the appropriate driving technique. These difficulties will have been borne in mind when the routes and exits from the beaches were originally selected. The main types of beaches are shingle and sand and the techniques to be used are detailed below:

19.1 Shingle, rocky and stony beaches. Provided that vehicles are not allowed to stop and that pushing parties are available, loose shingle beaches can be negotiated. Bottom gear should be used. For hard stony beaches, provided the stones are not covered with slippery seaweed and the beach is not steep, change into second gear when the vehicle is clear of the water's edge.

19.2 Sandy beaches with wet patches. Hard sand with wet patches is not difficult to negotiate, although the wet patches may affect the steering. These patches are easily recognised as being darker in colour than hard sand. They must be crossed with front wheels straight and without any reduction in speed. Pools of water should be avoided if possible, because their depth and underwater surface are uncertain. If unavoidable, they should be reconnoitred first on foot and then crossed cautiously.

19.3 Hard sand beaches with strips of soft sand. A strip of soft sand may be found between the high water mark and beach exits, although the remainder of the beach is firm. These strips should be approached as fast as possible either in bottom or second gear. The wider the strip, the lower the gear. Changing gear on the strip is not recommended, as momentum is lost. All-wheel drive must be used and the steering wheel held firmly keeping the front wheels straight. Turning should not be attempted unless absolutely necessary. If the vehicle should stick in the sand, the driver must back out at once. By rocking the vehicle backwards and forwards a firm patch can be made to enable it to be reversed out.

19.4 Soft sandy beaches. These are the worst conditions likely to be encountered, and it is useless to attempt to rush the beach as is done with the strips of soft sand as in Para 19.3 above. The vehicle tyres pressure which may have been lowered for fording will afford some assistance to the tractive effort but vehicles may still require manual assistance before they reach a hard surface or a prepared beach roadway. No attempt should be made to approach a soft sandy beach at an angle and the beach slope should be taken head on in bottom gear, using low reduction gear when fitted. If the vehicle loses forward momentum the driver must stop as wheel spin will only cause the vehicle to sink in deeper. Recovery procedure as detailed hereafter must be taken.

20 On large scale landings, and prior to the first wave of 'B' vehicles to be landed, a 'Class 30 Assault Trackway' will be laid right up the beach. This trackway provides a hard surface, and as soon as vehicles are clear of the water, drivers can resume normal driving.

21 The procedure detailed above refers to wheeled vehicles. Tracked vehicles generally present no difficulties. Turning places for this equipment should be chosen on ground which has some support such as heather or other vegetation growing on it.

DRIVER TRAINING FOR FORDING OPERATIONS

Training

22 Training courses for driver training of vehicles and equipment for fording operations is the responsibility of the Training Wing, 11(ATT) Sqn, 1ASRM, Instow. It is pointed out in Para 5 that most causes of failure are attributable to inexperienced driving and it is, therefore, essential that all drivers taking part in an amphibious operation must be suitably trained for this task.

23 Sufficient time, equipment and facilities for this training must be allotted. The driver's training falls into five main stages:

23.1 Handling of vehicles on and off ramps of landing craft. Before exercising with the actual craft, this can be practised ashore with mock-up ramps or earth banks.

23.2 Stowage of vehicles in landing craft. This is best done in the early stages using taped spaces representing landing craft stowage areas.

23.3 Beach driving. The handling of vehicles on sand, shingle, or mud similar to the nature of the beach to be assaulted.

23.4 Beach control. Traffic control in conjunction with the Beach Provost Section.

23.5 Waterproofing and de-waterproofing. This type of training is dealt with in greater detail in Chap 2.

24 When drawing up a programme for driver training, it is important to remember that some vehicles taking part in an operation with any particular unit may come from other supporting units, e.g. RA, RLC or REME. The drivers of these vehicles must undergo training identical to that carried out by the RM drivers and they should, if possible, be included with the latter while training is being carried out. Every driver taking part in an amphibious operation must be given the opportunity of driving a vehicle under fording conditions so that not only will he feel what it is like to drive in a semi-immersed state, but he will appreciate how the vehicle reacts while fording.

BEACH RECOVERY AND DROWNED VEHICLE PARK

25 In any fording operation, a beach recovery detachment is essential, since one vehicle drowning at the foot of the ramp or bogging down on the beach roadway or in a narrow exit, can bring disembarkation to a complete standstill. The primary aim of the beach recovery section is to maintain a clear passage from ship to shore and across the beaches in order that the maximum number of equipment should reach the forward area in the shortest possible time. The secondary task as opportunities arise is the recovery of drowned equipment to the drowned vehicle park so they can be put back into fighting condition by the drowned vehicle team as quickly as possible.

26 The main equipment used is a Beach Recovery Vehicle (BRV) which is able to operate safely in [REDACTED]. For operations on the dry beach a standard recovery vehicle is used.

27 Since the BRV may be required at the outset of a landing, [REDACTED] with its duty confined to keeping clear the route between the ship's ramp and the beach roadway. In the early stages of the operation, the BRV [REDACTED]

28 If a vehicle has failed in the water gap, the BRV will be detailed to assist. The driver of the drowned equipment should have his vehicle in neutral and the co-driver or crew member should be holding the throwing line attached to the tow rope for immediate coupling to the recovery vehicle. For speed it may be necessary for the BRV to resort to pushing rather than towing, but whatever method is to be adopted will be indicated by the BRV commander to the crew of the drowned vehicle. His instructions must be obeyed.

29 There is little that crews can do on the 'self-help' principle during fording other than that already detailed in Para 9. Once having reached the beach or at about 2 ft. of water, manual recovery may be used to augment the resources of the beach recovery section. Pushing parties are of great assistance on soft ground, but pushing must always begin before the vehicle comes to a halt. Pushing must always take place from the rear of the vehicle and must be upward as well as forward in order to lift the weight off the wheels. Pushing parties are only effective on equipment carrying a load of not more than 4 tonnes. If a vehicle has to be dug out of soft sand, the following rules must be observed:

- 29.1 See that the front wheels are pointing straight ahead.
- 29.2 Select a parking place on firm ground to which it is intended to drive the vehicle once it is movable.
- 29.3 Select bottom gear, all-wheel drive and low reduction and drive slowly forward to firm ground.

CHAPTER 5

TREATMENT OF DROWNED VEHICLES AFTER RECOVERY

CONTENTS

Para		Page
	Introduction (CAUTIONS)	
1	General	
5	Causes of failure	
6	Precautions 'A' vehicles	
12	Precautions 'B' and 'C' vehicles	
	Vehicle repairs	
17	Vehicle disposal	
19	Movement of 'A' vehicles	
20	Diagnosis and remedial action for all drowned vehicles (WARNINGS) (CAUTION)	
23	Check for hydrostatic lock, Diesel engines	
24	Water contamination, Diesel engines (CAUTION)	
Table		
1	Workshop remedial action	6

INTRODUCTION

CAUTIONS

(1) **ENGINE DAMAGE. IF A VEHICLE HAS STALLED DURING ANY FORDING, NO ATTEMPT SHOULD BE MADE TO RE-START THE ENGINE AS SERIOUS INTERNAL DAMAGE WILL RESULT FROM THE EFFECT OF AN ENGINE HYDROSTATIC LOCK.**

(2) **ENGINE DAMAGE. IF A VEHICLE HAS FAILED DURING AN AMPHIBIOUS LANDING NO ATTEMPT SHOULD BE MADE TO RECOVER THE VEHICLE WHILST IN GEAR AS SERIOUS INTERNAL DAMAGE TO THE ENGINE WILL RESULT FROM THE EFFECT OF AN ENGINE HYDROSTATIC LOCK.**

(3) **EQUIPMENT REPAIR. THE INSTRUCTIONS IN THIS CHAPTER MUST BE COMPLETED BY A VEHICLE MECHANIC.**

General

- 1 The aim of this AESP is to give guidance on the repair of drowned vehicles. It covers:
 - 1.1 Failure of waterproofed vehicles during Fording.
 - 1.2 Accidental drowning of non-waterproofed vehicles.
- 2 Failure during fording may be relatively simple to rectify since it is possible that only one component is affected. During amphibious operations, it is a vital vehicle mechanic task to make these vehicles operational again as quickly as possible at the Drowned Vehicle Park (DVP).
- 3 Complete flooding of vehicles that have not been waterproofed, is much more serious and will inevitably result in extensive workshop repairs **WHICH MUST BE STARTED AT ONCE** before further damage occurs. All equipment must be back loaded for Level 4 (L4) repairs within 24/48 hours and HQ's ES staff is to action the relevant DE&S PT managing the equipment for transport and repair.

- 4 During recovery, it is essential that the drowned vehicle's transmission should be disengaged.

Causes of failure

- 5 The main causes of failure are:
- 5.1 Mechanical and/or electrical component system failure either due to **incorrect waterproofing** or in the case of 'A' vehicles, flooded engine and crew compartments.
 - 5.2 Stalling due to **poor driving**, obstacles, soft sand or mud.
 - 5.3 **By fording too deep**, i.e. in a depth greater than that specified for the equipment.

Precautions 'A' vehicles

- 6 Disengage the drive from the main engine to the transmission before the vehicle is moved.
- 7 Remove all ammunition, pyrotechnics and any other form of explosives.
- 8 Where fitted, Laser range finders will be locked in the 'SAFE' position.
- 9 Remove all hull drain plugs.
- 10 Vehicles which have drowned in sea water remove and drain the batteries; keeping your face well clear of the battery vents in case chlorine gas is trapped in the battery cells.
- 11 Where possible, wash down the hull interior with fresh water.

Precautions 'B' and 'C' vehicles

- 12 These precautions to be observed are also related to other soft skinned vehicles, such as 'C' vehicles and plant equipment.
- 13 Do not attempt to start the main engine or tow the vehicle whilst in gear.
- 14 Whilst towing the vehicle in neutral, the efficiency of the vehicle brakes will be degraded, so towing speed should therefore be kept to a minimum.
- 15 **DO NOT** attempt to start the engine until the checks detailed in Para 23 are completed.
- 16 Disconnect the vehicle and radio batteries; if the batteries are flooded with sea water, keep your face well clear of the battery vents.

VEHICLE REPAIRS

Vehicle disposal

- 17 It is imperative that all vehicles which have drowned should be admitted to a designated workshop for repair with the least possible delay. This is particularly important where vehicles are fitted with specialised electronic equipment, because corrosion and deterioration develops rapidly unless speedily rectified.
- 18 The drowned vehicle must be recovered as soon as possible. Full details are to be telephoned through normal ES channels to the relevant DE&S PT for the equipment, who must arrange immediate repair.

Movement of 'A' vehicles

19 The unit concerned will arrange with the local Transport and Movements Office Royal Logistics Corps (RLC) for the immediate movement of the vehicle from its recovered location to repair workshops as appropriate. Movement of the vehicle must not be delayed beyond 24 hours and the local HQ's ES staff will ensure that the necessary priority is allocated to this movement.

Diagnosis and remedial action for all drowned vehicles

WARNINGS

(1) **HEALTH HAZARD. PX-24 IS A TOXIC SUBSTANCE WHICH MUST NOT BE CONSUMED. AVOID CONTACT WITH SKIN AND EYES. WEAR PROTECTIVE GLOVES AND GOGGLES WHEN HANDLING PX-24. IN THE EVENT OF SLIGHT SKIN/EYE CONTACT, THOROUGHLY RINSE THE AFFECTED AREA WITH WATER. IF THERE IS EXCESSIVE SKIN/EYE CONTACT OR INGESTION SEEK MEDICAL ATTENTION IMMEDIATELY.**

(2) **NO SMOKING OR NAKED FLAMES. USE ONLY IN WELL VENTILATED AREAS.**

CAUTION

ENGINE DAMAGE. PX-24 IS A WATER DISPLACING FLUID AND NOT A LUBRICANT. IT HAS A LOW FLASH POINT AND IT IS IMPORTANT THAT THE ENGINE IS NEVER RUN WITH THE SUMP FILLED OR PARTIALLY FILLED WITH PX-24.

20 Where waterproofed vehicles drown whilst engaged in amphibious assaults across beaches, failure may be due to defective waterproofing of one particular component. Diagnosis and rectification is not a major problem and on average, a drowned waterproofed vehicle can be returned mobile using procedures contained in Para 23 and 24.

21 Drowned vehicles which are not waterproofed, will require greater effort to make them serviceable. Table 1 outlines the procedures and must be read in conjunction with Para 23 and 24. It should be noted that Table 1 is only a guide and there may be additional tasks depending on the vehicle design.

22 Vehicle mounted or transported equipment such as radio installations, guided weapon sets, armaments and associated stores will require immediate treatment. Where possible, release trapped water, spray internally and externally with PX-24. Equipment should then be immediately delivered to a workshop so that repairs can be carried out with the minimum of delay in order to reduce corrosive damage to the equipment.

Check for hydrostatic lock, Diesel engines

23 If the equipment has been subject to prepared fording, check that the crew have completed de-waterproofing stage 'C' of the AESP Category 421. The following procedure to eliminate engine hydrostatic lock must be completed for all drowned vehicles:

23.1 Check the engine air cleaner and engine air intake hoses for water contamination. Remove all traces of water. Replace the air cleaner filter with a new one, if possible. If new ones are not available, dry out the old element before re-fitting.

23.2 If fitted, remove the inter-cooler drain plugs and drain off any water contamination. Refit the drain plugs.

23.3 Check for hydrostatic lock. Remove the fuel injectors or engine glow plugs, turn the engine by hand. If water is expelled, operate the starter motor for short periods to hasten the ejection of water.

23.4 Fill each engine cylinder with PX-24, turn the engine until all fluid is expelled.

23.5 It may be necessary to siphon the PX-24 out of some piston crowns, depending on the type of piston fitted to the particular engine.

23.6 Refit engine fuel injectors and glow plugs.

NOTE

If the engine cannot be turned by hand, it may be seized with catastrophic internal damage. This may ultimately require a replacement engine assembly.

Water contamination, Diesel engines

CAUTION

ENGINE DAMAGE. IN CASES WHERE THE OIL LEVEL IS EXCESSIVELY HIGH, THE ENGINE MUST NOT BE RUN UNTIL THE PROCEDURES DETAILED IN PARA 24 HAVE BEEN COMPLETED.

24 Check the engine oil level. If the oil level is not excessively high, the engine can be run without changing the oil immediately. Start the engine, it may run erratically at first, but as the engine warms up, the performance should return to normal. If the level is above the **FULL** mark, water entry into the sump must be suspected. Visually examine the oil for emulsification (a yellow milky appearance will indicate the presence of water in the oil). If water is present, complete the following procedures:

24.1 Drain the sump (removing all drain plugs).

24.2 Remove the oil filters, drain and refit.

24.3 Replace the drain plugs and fill the sump to 2/3 capacity with PX-24.

24.4 Remove the fuel injectors or glow plugs.

24.5 Turn the engine by hand to agitate the PX-24.

24.6 Drain off the PX-24 (remove all drain plugs) from the sump.

24.7 Replace the oil filters with new ones, if possible. If new ones are not available, wash out the old filters with PX-24 and saturate with clean engine oil before refitting.

24.8 Refit the injectors and glow plugs.

24.9 Refit drain plugs and fill the sump with the correct grade oil to the normal level.

24.10 After changing the engine oil, the engine should be run for 10 minutes on a fast tick over. Recheck engine oil and repeat the procedure as necessary.

NOTE

The warm air flow from the radiator is the best means of drying out the engine compartment.

25 When the engine starts, check the oil pressure gauge or low pressure warning light for normal behaviour. If no oil pressure is registered after one minute, switch off the engine and trace the cause. If pressure is registered, but abnormal fluctuations are shown, it is probable that water is still present. Run the engine for 10 minutes and examine the oil. Should water be present, drain and refill with fresh oil.

NOTES

- (1) It is practically impossible to clear every drop of water from a lubrication system using these first aid treatments, but the contamination can be reduced to an acceptable level and avoid damage to the engine. The oil should be examined regularly and drained and replenished at the earliest opportunity.
- (2) Where the equipment is urgently required, the following may apply: if only slight discoloration or rise in the level is apparent, it should be possible to defer draining and refilling until the situation allows or stage 'D' of the waterproofing AESP to be carried out. Even with moderate contamination flushing with PX-24 can be omitted and a straight drain and refill carried out. With heavy contamination (above 15% water entry), full flushing procedure is necessary.

TABLE 1 WORKSHOP REMEDIAL ACTION

Ser (1)	Component (2)	Remedial action (3)
Engine and Transmission		
1	Engine	Drain oil, flush with PX-24, drain and refill with clean oil
2	Engine oil filter	Drain and flush or renew oil filter
3	Gearbox and transfer box	Drain oil, flush with PX-24, drain and refill with clean oil
4	Drive axles	Drain oil, flush with PX-24, drain and refill with clean oil
5	Engine air filter	Clean system of water, renew filter element
6	Turbo charger inter-cooler	Drain off any water contamination
Brake systems		
7	Air servos	Clear system of water contamination
8	Hydraulic servos	Check hydraulic fluid, drain and renew if contaminated
9	Air compressor	Check oil, drain and renew if contaminated
10	Compressed air reservoirs	Drain storage tanks and clear any water contamination
11	Air pipes	Clear pipes of water contamination
Electrical items		
12	Starter motor	Wash with PX-24
13	Alternator	Wash with PX-24
14	Battery	Drain contaminated electrolyte, refill with clean electrolyte
15	Instrument panel	Spray with PX-24
16	Electronic Control Units (ECUs)	Replace damaged units
17	Wiring harnesses	Clean connectors with PX-24. Replace damaged harnesses
18	Fuse boxes	Clean and spray with PX-24. Replace damaged fuses.
19	Electrical relays	Replace damaged relays
20	Vehicle lights	Dismantle, clean and spray bulb connections with PX-24
Fuel systems		
21	Fuel tank	Drain fuel tank, refill with clean fuel
22	Fuel sediment and filter unit	Drain off contaminated fuel. Renew filter
23	Fuel pipes	Clean pipes of contaminated fuel
24	Fuel pump	Operate until clear of contaminated fuel
25	Fuel injection pump	Drain off contaminated fuel from cam casing and fuel gallery
26	Fuel injectors	Remove and connect to the injection pump. Operate until all traces of contaminated fuel are removed

ARMY EQUIPMENT AND SUPPORT PUBLICATION (AESP) AND ELECTRICAL AND MECHANICAL ENGINEERING REGULATIONS (EMER) - FORM 10

*AESP/EMER NUMBER:		*IS THIS SAFETY RELATED?	Yes	<input type="checkbox"/>	No	<input type="checkbox"/>
--------------------	--	--------------------------	-----	--------------------------	----	--------------------------

Send Form 10 via the Email or Post address. However, email is preferred.		Tel:	
Email: DEAL.E-Form10@med.uk	Post to:	Form 10 Cell Land Equipment Elm 3b #4330 MOD Abbey Wood Bristol BS34 8JH	
(Give a copy of the form and email to the above address. If the link fails, copy address and paste into email client)			

ORIGINATORS DETAILS			
*Address			*Name
			Rank / Grade
			*Phone
			*Senders Reference
			*Date Raised
*E-Mail			Eqpt Asset Code (if applicable)

AESP/EMER DETAILS							
*Full Title of AESP/EMER (Not the AESP/EMER Number)							
*Edition	*Amendment	*Chapter	*Page	*Paragraph	Figure	Instruction	Other
*Comments: if additional information is to be supplied, please e-mail with the Form 10 as separate attachments.							

FORM 10 CELL USE			
*Date Received		*Form 10 Reference	
*Date Sent to PT / SME		Problem Report	

PROJECT TEAM / SME RESPONSE TO COMMENTS:			
Project Team (PT) / SME		*Sponsors Name	
*Phone		Rank / Grade	
*Email		*Date Received	
*The following action is to be carried out:	Mark:		Mark:
Issue a revised/amended AESP/EMER:		Under investigation:	
Incorporate comment(s) in future amendments:		No action required:	
Remarks:			
SPONSOR/PT FINAL CLOSURE STEPS	Mark:	Form 10 Cell notified of Date action taken	Date:
Form 10 Originator notified of the action taken:			

AESP Form 10 (Issue 6.2 dated July 13)

- * Mandatory Fields for Originator
- * Mandatory Fields for Sponsor.

ARMY EQUIPMENT AND SUPPORT PUBLICATION (AESP) AND ELECTRICAL AND MECHANICAL ENGINEERING REGULATIONS (EMER) - FORM 10

Form 10 Guidance

Form 10 can be found within the AESP or, as a template, from the JAMES Portal (Hot Topic – Forms) & TDOL (FORM10).

Originator responsibility is to enter the following details marked *:

- In the **AESP/EMER Number:** cell enter the full document number e.g. AESP 1256-I-400-711.
- Is this **Safety Related?** – select Yes or No as appropriate.
- Originator Details:
 - Full address Inc Post Code or BFPO NO.
 - Originator email address
 - Senders Reference – that must be unique.
- AESP Details shall enter the following details:
 - The Full Title of AESP/EMER should not include the AESP/EMER Number
 - Enter details in all other mandatory fields marked *.
 - Additional information relating to the Comments (AESP copies, additional text details or photographs) should be attached to the Email at the same time.
- Originator makes up the Form 10 & Sends to Form 10 cell via
 - Email: Save a copy of the form and send to DESLE-Form10@mod.uk Copy the address and paste it into your email client
 - Post to Form 10 Cell Form 10 Cell, Land Equipment, Elm 3b #4330, MOD Abbey Wood, Bristol, BS34 8JH.
 - **Any AESP that holds a Security marking higher than 'Restricted' should be securely circulated.**

FORM 10 CELL responsibilities:

The Form 10 Cell enters:

- Date Received
- Form 10 Reference
- Date sent to Sponsor
- Register all Form 10 details in the MOSS Form 10 Tracker.

Sponsor Responsibility

The Sponsor will:

- Enter their name, email address & phone contact details.
- Enter Date Received
- Enter Details in the non-mandatory field as & when required.
- Acknowledge receipt of Form 10, within 5 working days, by email to Form 10 Cell.
- Assess the contents of comments and details received.
- Mark the relevant Action box and fill out the Remarks field.
- Enter date when the Form 10 is returned to Form 10 Cell.
- Email copy of completed Form 10, within 6 weeks, to the Form 10 Cell and Originator.

Form 10 Cell on receipt will:

- Record final stage of the Form 10 into the MOSS Form 10 Tracker.
- Close off the Form 10 and archive.

AESP Form 10 (Issue 6.2 dated July 13)

* Mandatory Fields for Originator

* Mandatory Fields for Sponsor.