

OPINION UNDER SECTION 74A

| | |
|---------------------|---------------------------------|
| Patent | EP 2532841 B1 |
| Proprietor(s) | United Technologies Corporation |
| Exclusive Licensee | |
| Requester | Rolls-Royce |
| Observer(s) | |
| Date Opinion issued | 07 March 2019 |

The request

1. The comptroller has been requested by Rolls-Royce (the Requester) to issue an opinion on whether the flexible support structure for a geared architecture gas turbine engine of EP(GB) 2532841 B1 (the Patent) is valid. More specifically the Requester has asked for an opinion of validity on the following grounds:
 - (i) whether all claims of the Patent lack an inventive step in light of documents D1-D11 provided by the Requester, and
 - (ii) whether the Proprietor is entitled to the Patent, and
 - (iii) whether the disclosure is sufficiently clear and complete for the invention to be carried out by a person skilled in the art, and
 - (iv) whether claims 11, 12, 13 of the Patent includes added matter through intermediate generalisation and/or are adequately supported.

2. The request was received on the 8th November 2018 and was accompanied by a statement explaining the request as well as copies of the various documents relied on. These are as follows:
 - (P1) US 2011/61494453P (United Technologies)*
 - (D1) US 5433674 B1 (United Technologies)*
 - (D2) US6223616 B1 (United Technologies)*
 - (D3) US 2010/105516 (United Technologies)*
 - (D4) US 2011/0130246 A1 (United Technologies)*
 - (D5) ANSI-AGMA 6123-B06*
 - (D6) "Optimised Gearbox Design for Modern Wind Turbines" Hicks Cunliffe and Giger 20th November 2004.*

(D7) "Quiet Clean Short-Haul Experimental Engine (QCSEE) Main Reduction Gears Detailed Final Report", NASA CR-13872. March 1975

(D8) "Energy Efficient Engine Preliminary Design and Integration Studies" NASCAR-135396. November 1978

(D9) "Expansion of Epicyclic Gear Dynamic Analysis Programme; Final Report", NASA CR-179563. August 1986

(D10) "Load Sharing Behaviour in Epicyclic Gears: Physical Explanation and Generalizes Formulation", Avinash Singh, Mechanism and Machine Theory 45 (2010) pp 511-530 published online 24th November 2009.

(D11) "PurePower PW1000G Engine: Customer Testimonials", Youtube video published 26th July 2010.

3. Observations were filed by the Proprietor on the 21st December 2018. Observations in reply were filed by the Requester on 18th January 2019 in which the Requester seeks support for part of their argument in pre-grant communications from the EPO in relation to related patent applications EP 3045684 A, EP 3098396 A and EP 3296526 A1.
4. Both sides sought to submit further observations. The opinion service however only provides for the three rounds of correspondence hence the submissions filed after the observations in reply have not been considered.

Whether all parts of the request are allowable

5. The comptroller will only issue an opinion in relation to a prescribed matter, this is by virtue of section 74A(1) of the Patents Act 1977 (the Act). The matters for which an opinion may be sought are prescribed at rule 93(6) of the Patents Rules 2007, as amended, (the Rules). These matters do not include whether the patent was granted to a person not entitled hence I am not able to give an opinion on that aspect of the request.
6. The comptroller will also not issue an opinion if for any reason he considers it inappropriate in all circumstances to do so, this is by virtue of section 74A(3)(b) of the Act. In particular, a request will be refused which does no more than repeat arguments already considered pre-grant.
7. Documents (D1), (D2) and (D3) were each discussed in relation to novelty and inventive step during the pre-grant prosecution of the Patent at the EPO. Any request for an opinion on validity that argues on the basis of prior art that has previously been cited in the X or Y category does not, other than in exceptional circumstances¹, raise a new question. D1-D3 were cited in the X category during pre-grant proceedings. I do not consider the circumstances here exceptional and therefore I will not consider documents D1-D3.
8. Additionally, I am of the opinion that the Requester has not set out an argument in respect of documents D7-D11 that is clearly distinct from that made in relation to in particular D4. I also note that the argument in respect of D11 appears to relate to a different patent to that in issue here. I will therefore disregard D7-D11.

¹ BL 0/370/07

9. The request also seeks an opinion on various matters relating to whether the Patent discloses the invention clearly enough and completely enough for it to be performed by a person skilled in the art (sufficiency) and also whether the disclosure in the specification of the Patent extends beyond that disclosed in the application for the Patent, as filed (added matter).
10. The Proprietor notes that an examiner will always examine for these matters and hence the lack of any specific objection during examination would indicate that the examiner is satisfied that the application is sufficient and does not add matter. The approach however taken by the IPO when a request has referred to these grounds is to provide an opinion unless the issue has been explicitly considered during examination.
11. In that respect I note that the European Search Opinion dated 15th May 2014 objected to the term '*gear mesh lateral stiffness*' as violating Article 83 EPC (Disclosure of the invention). The objection was subsequently dropped in response to argument from the applicant. It is therefore understood that the sufficiency of this term, so far as it is used in claims 11-13 of the Patent, has been previously considered. As part of that consideration the EPO examiner would have undoubtedly also considered the terms 'stiffness' and 'lateral stiffness' and therefore it is my opinion that the request here in relation to sufficiency so far as it relates to the terms "stiffness", "lateral stiffness" and "gear mesh lateral stiffness" does not give rise to a new question.
12. I would add that in its observations in reply the requestor refers to apparently related pending applications where the EPO examiner has objected to claims including these terms. It is arguable that this is not strictly evidence in reply. The Requester could have provided this additional evidence in their request but did not do so. If they had then the Proprietor would have had an opportunity to make observations on them. In the event I do not believe they help the Requester since unlike the consideration by the EPO examiner on the patent here, the consideration in the pending actions is not final. Hence I am justified in not providing an opinion on the sufficiency of the Patent based on these terms.
13. The Request in respect of added matter focuses on what is often referred to as 'intermediate generalisation'. More specifically the Requester argues that claim 11 relates to only a three way lateral stiffness relationship whereas the embodiments on which it relies disclose a five way relationship including also the lateral stiffness of a ring gear and planet journal bearing. The Requester alleges that, in the absence of any such five way relationship, the lateral stiffness of the claimed components may be more or less than the lateral stiffness of the gear mesh. The Requester makes similar assertions in regard to the lateral stiffness of a ring gear of claim 12, and a planet journal bearing of claim 13.
14. The Requester also contends that the Patent is insufficient as whilst the disclosure is limited to a star or planetary epicyclic gear arrangement, the claims extend beyond such gear arrangements. Hence there is no disclosure that would enable the skilled person to realise the full scope of the claim. Further claims 1 to 13 cover arrangements where the lateral stiffness of the various components of the invention could be 0% of the reference stiffness. This would require unworkable and undisclosed infinite flexibility.

15. I am of the opinion that the request regarding added matter is valid, as is the request regarding sufficiency in relation to the unbounded range. The remaining matters relate to clarity and/or support and are therefore not provided for under the opinions service.
16. Hence having regard to the entirety of the request, which with attached documents runs to over 900 pages, and mindful of the reasons set out above together with the aim of the opinions procedure to be a relatively quick and simple process, I believe it is appropriate to limit my opinion to the following matters:
 - (i) whether all claims of the Patent lack an inventive step in light of documents D4-D6 provided by the Requester, and
 - (ii) whether the disclosure is sufficiently clear and complete for the invention to be carried out by a person skilled in the art, in particular in regard to the absence of a lower limit to a claimed range.
 - (iii) whether claims 11, 12, and 13 of the Patent includes added matter through intermediate generalisation.

The Patent

17. The Patent is entitled, "Flexible support structure for a geared architecture gas turbine engine" and was filed on 1st June 2012 having an earliest priority date of 8th June 2011. The Patent was granted on the 27th April 2016 and remains in force.
18. The Patent relates to a geared gas turbine engine and specifically to a flexible support structure for a fan drive gear system (FDGS) of a gas turbine engine. A geared gas turbine engine allows the fan, which provides a large proportion of thrust, to be operated at an optimum speed independent from the speed of a core engine. This allows additional optimisation of fan size and bypass ratio. However, the gearing system is subject, during flight, to lateral loading that causes misalignment between gear train components; this reduces overall efficiency and inevitably leads to accelerated wear.
19. The Patent specifically relates to supporting of a shaft, and supporting of the gear system within the gas turbine engine such that the FDGS may be, to some extent, isolated from any lateral distortion thereby maintaining alignment with the shaft. The invention is defined by two distinct embodiments each relating to a similar concept of maintaining alignment between the FDGS and its output, for example a sun gear or a fan shaft of a gas turbine engine. The overarching principle is discussed below in reference to figure 3 of the Patent which illustrates a sectional view through a gas turbine engine.
20. The gas turbine engine of the Patent comprises a fan shaft 76 supported by a frame 82, typically via bearings 38A and 38B. A gearbox is at least partially supported by a flexible support 78. Both the frame 82 and the flexible support are mounted to a static structure which would typically be an annular core engine casing or similar load bearing structure of a gas turbine engine. The gearbox

receives an input, typically from an engine shaft, via an input coupling 62. Under heavy load the casing 36 tends to deform whilst the fan shaft will maintain alignment with the gearbox as any deformation is compensated by the flexible support and the coupling, both of which will deform sooner than the fan shaft support frame.

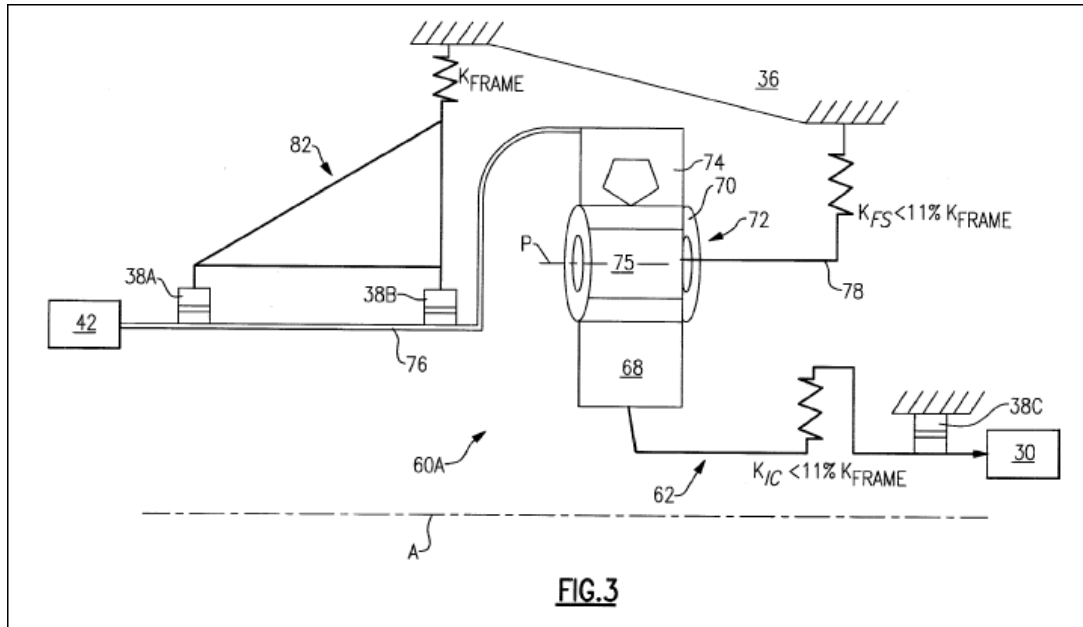

21. The Patent contains claims 1-13 of which claims 1 and 11 are independent claims. These read as follows:

Claim 1. A geared architecture (48) for a gas turbine engine (20) comprising:

a fan shaft (76);

a frame which supports said fan shaft (76), said frame defines a frame lateral stiffness (K_{frame});

a gear system which drives said fan shaft (76);

a flexible support (78) which at least partially supports said gear system,

an input coupling (62) to said gear system (60)

characterised in that

said input coupling (62) defines an input coupling lateral stiffness (K_{IC}) with respect to said frame lateral stiffness (K_{frame}) of less than 11% of said frame lateral stiffness (K_{frame}); and

said flexible support (78) defines a flexible support lateral stiffness (K_{FS}) with respect to said frame lateral stiffness (K_{frame}) of less than 11% of said frame lateral stiffness (K_{frame}).

and

Claim 11. A geared architecture (48) for a gas turbine engine (20) comprising:

a fan shaft (76);

a frame which supports said fan shaft (76);

a gear system which drives said fan shaft (76), said gear system (60) includes a gear mesh that defines a gear mesh lateral stiffness (KGM)

a flexible support (78) which at least partially supports said gear system (60);

and

an input coupling (62) to said gear system (60),

characterised in that

said input coupling (62) defines an input coupling lateral stiffness (KIC) with respect to said gear mesh lateral stiffness (KGM) of less than 5% of said gear mesh lateral stiffness (KGM); and

said flexible support (78) defines a flexible support lateral stiffness (KFS) with respect to said gear mesh lateral stiffness (KGM) of less than 8% of said gear mesh lateral stiffness (KGM), wherein said gear mesh lateral stiffness (KGM) is defined between a sun gear (68) and multiple planet gears (70) of said gear system (6).

Added matter – the law

22. The Requester alleges that the Patent has been amended such that the Patent discloses matter extending beyond that disclosed in the original application. Section 76(2) of the Act reads;

No amendment of an application for a patent shall be allowed under section 15A(6), 18(3) or 19(1) if it results in the application disclosing matter extending beyond that disclosed in the application as filed.

23. The Requester alleges that claims 11-13 of the Patent disclose matter extending beyond that disclosed as filed. The Requester relies on the content of the Manual of Patent Practice paragraphs 76.15.3-76.22 to support their allegation. In particular the Requester argues;

“As set out in MPEP² 76.15.14 (reproduced below) if a claimed feature is taken from an embodiment, stripped of other related features of the embodiment, then unless the application suggests this feature has particular significance, the claim is likely to constitute an intermediate generalisation.”

² The Manual of Patent Practice

“76.15.3 Amendments which limit the scope of a claim by the introduction of one or more features from the description or claims may in certain circumstances add matter through what is known as “intermediate generalisation”. This concept was explained by Pumfrey J in Palmaz’s European Patents (UK) ([1999] RPC 47, upheld on appeal [2000] RPC 631):

“If the specification discloses distinct sub-classes of the overall inventive concept, then it should be possible to amend down to one or other of those sub-classes, whether or not they are presented as inventively distinct in the specification before amendment. The difficulty comes when it is sought to take features which are only disclosed in a particular context and which are not disclosed as having any inventive significance and introduce them into the claim deprived of that context. This is a process sometimes called ‘intermediate generalisation’.”

76.15.4 This definition has been endorsed in subsequent decisions of the courts, such as Vector Corp v Glatt Air Technologies Ltd [2007] RPC 12. In particular, if a feature is taken from only one, or a subset, of the embodiments, stripped of the other related features of the embodiment(s), and claimed as a defining feature of the invention, then unless the application suggests that this feature has a particular significance this is likely to constitute an intermediate generalisation; as in Datacard Corp. v Eagle Technologies Ltd. [2011] EWHC 244 (Pat), [2011] RPC 17.”

24. Claim 11 has been amended to recite, in their entirety, the features of claims 10-12 and 15 as originally filed and published in EP 2532841 A2. Each of the original claims 11, 12 and 15 was directly dependent on original claim 10 and therefore have not been stripped of any related features, and clearly have a particular significance.
25. Therefore in my Opinion claims 11-13 do not disclose matter extending beyond that disclosed as filed.

Sufficiency – the law

26. The law relating to sufficiency is set out in section 14(3) of the Act, which states:

14(3) The specification of an application shall disclose the invention in a manner which is clear enough and complete enough for the invention to be performed by a person skilled in the art.

27. The Requester alleges that the Patent is insufficient as the invention is claimed such that the relative lateral stiffness of the input coupling and flexible support could be 0%; that is to say that these components would be infinitely flexible.
28. The Proprietor argues that *“where the skilled person recognises that a range is intrinsically limited, such as where extremely high or low values cannot be*

obtained, this does not give rise to an insufficiency objection”.

29. It is my opinion that the skilled reader would understand the function of the input coupling to be one of transferring torque from a spool of a gas turbine engine to a transmission of a gas turbine engine. The skilled person would understand that the minimum stiffness of this component would be such that it could perform this function and therefore would not extend to ‘infinite flexibility’. Similar consideration is given to the flexible support which requires sufficient stiffness in order to at least support a FDGS. Hence, I am not persuaded that the claims are insufficient in this respect. I note that the communications from the EPO in relation to similar issues in EP 3098396 A and EP 3045684 do not support this assessment. I am however neither bound by nor persuaded by those communications. I would note also that in, for example EPO Board of Appeal decision T0487/89, the EPO has allowed similar open-ended ranges.

Inventive step – the law

30. The Requester argues that claims 1 and 11 lack an inventive step in light of the disclosure of documents D4-D6 provided with the request. Section 1(1)(b) of the Act reads:

1(1) A patent may be granted only for an invention in respect of which the following conditions are satisfied, that is to say

(a) ...

(b) it involves an inventive step;

31. The provisions in relation to inventive step are found in section 3 which states:

3. An invention shall be taken to involve an inventive step if it is not obvious to a person skilled in the art, having regard to any matter which forms part of the state of the art by virtue only of section 2(2) above (and disregarding section 2(3) above)

32. The Court of Appeal in *Windsurfing*³ formulated a four-step approach for assessing whether an invention is obvious to a person skilled in the art. This approach was restated and elaborated upon by the Court of Appeal in *Pozzoli*⁴. Here, Jacob LJ reformulated the *Windsurfing* approach as follows:

(1)(a) Identify the notional “person skilled in the art”

(1)(b) Identify the common general knowledge of that person;

(2) Identify the inventive concept of the claim in question or if that cannot be readily done, construe it;

(3) Identify what, if any, differences exist between the matter cited as forming part of the “state of the art” and the inventive concept of the claim or the claim as construed.

(4) Viewed without any knowledge of the alleged invention as claimed, do those differences constitute steps that would have been obvious to the person skilled in

³ *Windsurfing International Inc. v Tabur Marine (Great Britain) Ltd*, [1985] RPC 59

⁴ *Pozzoli Spa v BDMO SA & Anor* [2007] EWCA Civ 588

the art or do they require any degree of invention?

33. In the first instance I will limit my consideration of the Patent, in relation to inventive step, to claims 1 and 11. If I find these claims to be obvious I will extend my consideration to the dependent claims.

The person skilled in the art and common general knowledge

34. Neither the Requester nor the Proprietor have defined the skilled person. I consider this person to be a gas turbine engine engineer, specifically the skilled person would be a specialist in the structural design of gas turbine engines and the mounting of accessories and auxiliary equipment including transmissions.

Identify the inventive concept of the claim in question or if that cannot be readily done, construe it

35. The Proprietor argues that the inventive concept of the claimed invention is the recognition that specific relative stiffnesses of certain components of the gear architecture support system are critical to the successful implementation of geared architecture in high-bypass geared turbofan engines.
36. Neither the Requester nor the Proprietor identify any problem with understanding the constructional arrangement of components as set out in the claims above. Specifically there is no contention over the arrangement of a fan shaft, a fan shaft support frame, a gear system, a flexible support, and an input coupling as claimed in claim 1 and 11.
37. However, there is some disagreement on the interpretation of several key terms, in particular; 'stiffness', 'lateral stiffness', 'gear mesh' and 'gear mesh lateral stiffness'. It is noted that these are argued exclusively on the basis of section 72(1)(c). Similarly, the Requester makes observations in regard to omitted limitations under section 72(1)(c), which has previously been considered.
38. In their argument the Requester sets out the conventional definition of stiffness;

“The stiffness, k , of a body is a measure of the resistance offered by an elastic body to deformation. For an elastic body with a single degree of freedom (DOF), the stiffness is defined as

$$k = \frac{F}{\delta}$$

Where, F is the force on the body and δ is the displacement produced by the force along the same degree of freedom.”

39. The Proprietor provides no argument specific to the term 'stiffness' and I have no reason to accept that anything but the conventional definition of the term is intended.
40. The Requester asserts that the term 'lateral stiffness' is understood to be *“a linear stiffness and reflects a deflection in a direction of an applied force. For example the force may be radial/perpendicular and the resulting deflection a linear*

displacement in a radial/perpendicular direction with respect to the axis of rotation". The Proprietor makes no comment to counter this typical understanding. Furthermore, there is nothing in the description that would allow me to deviate from this normal interpretation of the term. It is noted that in the correspondence issued by the EPO in regard to EP 3045684 A the examiner is explicit in the suitability, in terms of Article 84 EPC, of the term 'lateral stiffness'

41. The Requester argues that the term 'gear mesh' "*...is an interaction between two moving bodies...*". The Requester refers to 'Dynamic model of a helical gear pair with backlash and angle-varying mesh stiffness' (R2) to allege that; "*...gear mesh stiffness is not a constant value, it is a variable, a variable parameter cannot be used as a reference against which to define a relationship parameter...*".
42. The Proprietor does not provide any comment to dispute the interpretation of this term and the description does not provide me with any basis on which to deviate from the normal construction of the term 'gear mesh'. That is to say that a 'gear mesh' is a point at which two gears of a geared architecture interact in order to transmit torque.
43. The Proprietor agrees with the Requester in regard to the variation in stiffness of the gear mesh during rotation, in this instance, the Proprietor observes; "*the rotation would be so rapid that only the average stiffness would be perceived*". The Proprietor additionally argues that a force perpendicular to the rotation axis could be readily applied in order to determine the lateral stiffness of the gear mesh. The Proprietor relies on R2 to demonstrate that the skilled person would be able to model this accordingly both statically and dynamically.
44. I am of the opinion that term 'gear mesh lateral stiffness', and its component terms, needs no special construction wherein stiffness would inevitably be determined using the relationship $k=f(F, \delta)$. The term is understood to be a measure of resistance, offered by a system of interacting components of the gear mesh, to deformation in a direction perpendicular with respect to the axis of rotation of the gas turbine engine. This measure of resistance could be readily modelled by the skilled person trying to carry out the invention.
45. Hence I take the claimed inventive concept to lie in the specific relationships between the stiffnesses of various components as set out in the claims and as construed above.

Identify what, if any, differences exist between the matter cited as forming part of the "state of the art" and the inventive concept of the claim or the claim as construed.

46. D4 (US 2011/013026 A1) has a publication date of 2nd June 2011 and is entitled 'Mounting arrangements for a planetary gear train in a gas turbine engine'. D4 specifically discloses an apparatus for supporting a planetary gear train in a gas turbine engine as shown in the figure below which illustrates a sectional view through a gas turbine engine. The planetary gear train is supported by an input shaft 46, a fan shaft 34 and a mounting system composed of a deflection limiter 52 and a flex coupling 60. The input shaft and mounting system are configured to permit the planetary gear train 30 to move within a nacelle in order to account for

bending moments applied by the output shaft thereby maintaining alignment between components of the gear train. The invention disclosed in D4 therefore attempts to solve a similar problem as the Patent.

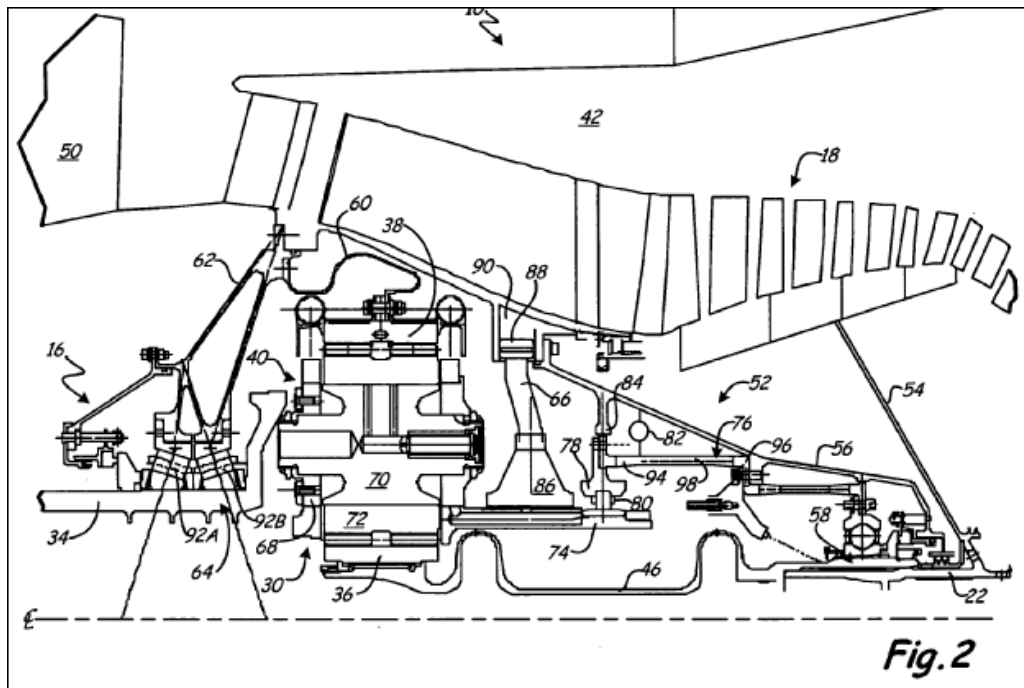

47. The fan shaft is supported by a support frame composed of struts 62 wherein the support frame carries a bearing assembly 64 that directly support the fan shaft much like the bearing systems 38A and 38B of the Patent. The struts 62 rigidly support the bearing assembly.
48. The input shaft 46 is coupled to a low pressure shaft 22 and configured to transmit torque between the input shaft and the planetary gear train. It is important to note, as the Requester has done, that the document explicitly discusses the absence of support bearings for the input shaft thereby permitting relative displacement of the gear train. Therefore the input coupling is considered to be flexible, particularly in respect to the struts 62.
49. The mounting system flex coupling 60 anchors a ring gear 38, or the gear train to a nacelle 42 via the support frame 62 and permits radial movement of the gear train.
50. The constructional features of D4 and their relevance to the Patent are argued convincingly by the Requester. The Requester's arguments in regard to the interpretation of D4, thus far, are not contested by the Proprietor.
51. I am in agreement in so much as D4 clearly and unambiguously discloses the general arrangement of components as required by the claim 1. Furthermore, in the absence of any disclosure to the contrary I understand D4 to imply a rigid gear mesh as this is entirely conventional. Therefore D4 additionally discloses the general arrangement of components as required by claim 11. However D4 fails to disclose the specific stiffness properties as required by the claims.

52. D5 is an American National Standard of American Gear Manufacturers Association (AGMA) and relates generally to design guidelines, amongst other things, relating to drive systems employing epicyclic gear arrangements. D5 appears to have been approved 20th September 2016. Although I am unable to confirm any publication date at this time, I will continue with my opinion under the assumption that D5 is Section 2(2) art as defined in the Act. If, however, D5 is significant I will have to consider this matter further. The Requester additionally asserts that D5 renders all claims obvious in light of D4 or D6
53. The Requester has discussed, in detail, the pertinent parts of D5 which they allege to be;
- i. The stiffness of a frame for supporting an output shaft (e.g. a fan shaft in an FDGS) a flexible gear support (which might include; a flexible support to the ring gear or planet carrier, or a planet journal bearing), a flexible input coupling, a ring gear, and a ring gear mesh are all critical to design of a gear system (claims 1, 11, 12, 13)*
 - ii. A design should be analysed under maximum loads expected to be encountered in operation.*
 - iii. The designer should adjust stiffness of one or more of a flexible gear support, a flexible input coupling, a ring gear, and a gear mesh until the best load sharing case is found.*
 - iv. There is a stiffness relationship (deflection) between an output support frame (e.g. for a fan shaft) and each of a sun input and a flexible gear support (e.g. ring gear support) (Claim 1).*
 - v. There is a stiffness relationship between each of the sun input and a flexible gear support (e.g. ring gear support) and a gear mesh (claim 12).*
54. The Proprietor argues that D5 is a generic document and finds no basis in the field of geared gas turbine engines and in particular has no relevance to any relationship between a gearbox support system and a fan shaft. The Proprietor additionally argues that D5 does not disclose any relationship between a gearbox support system and a frame supporting a fan shaft.
55. D5 demonstrates that it is known that epicyclic gear units are not designed in isolation and dynamic behaviour of the system, rather than the gear unit alone, must be considered. Here, the disclosure extends to a prime mover, the gear unit, the driven equipment as well as couplings and foundations. D5 additionally demonstrates that it is desirable to provide an epicyclic gear unit with floating components such as; gear rings, planet carriers and sun gears. The floating components provide improved load sharing which can account for manufacturing tolerances amongst other things. D5 further demonstrates that, where multiple floating components are used, additional calculations are required and several prototypes with incremental degrees of modification ought to be implemented in order to arrive at an optimised system.
56. D6 is entitled “Optimised gearbox design for modern wind turbines” and appears

to have been created on 20th November 2004, although I am unable to confirm any publication date at this time, I will continue with my opinion under the assumption that D6 is Section 2(2) art as defined in the Act. If, however, D6 is significant I will have to consider this matter further. The Requester alleges that D6 teaches a general concept of floating epicyclic gear components including an input coupling, or ring gear, with respect to a mechanical ground.

57. The Proprietor argues that D6 does not relate specifically to a geared architecture for a gas turbine engine and therefore fails to disclose a fan shaft, or a frame that supports the fan shaft, or any gear system that drives the fan system. The Proprietor additionally observes that the Requestor has failed to identify why the use of the epicyclic gearbox of D6 would be used in a geared gas turbine engine.
58. D6 discusses a Stoeckicht system which provides an epicyclic gearbox having a floating flexible outer ring gear, and a floating sun wheel. D6 additionally discloses a Hicks system which utilises flexible pins configured to permit planet gear deformation. The deformation afforded by the flexible pin is understood to be sufficient so as to account for manufacturing tolerances of cooperating components and therefore appropriate load sharing amongst discrete planet gears is achieved. The schematic at figure 3, reproduced below, clearly shows a fan, fan shaft and a mount for the fan shaft and epicyclic gearbox. D6 further discloses an epicyclic gearbox that would inevitably have a reduced gear mesh stiffness provided by a flexible pin, as well as a flexible input coupling provided by the floating sun wheel, and a flexible support provided by a flexible outer ring.

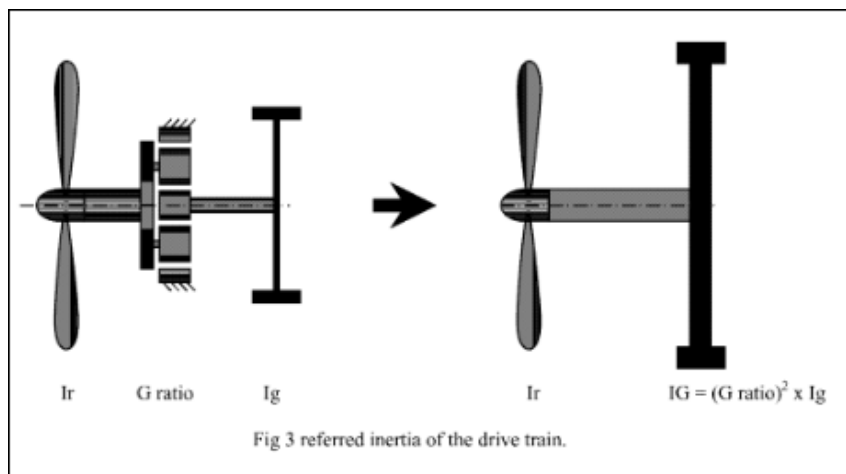

59. In my opinion D5 discloses normal design considerations that would be available to the skilled person as part of the common general knowledge. Similarly, although directed towards wind turbine generators rather than gas turbine engines, the specific design considerations in respect to the epicyclic gearbox of a wind turbine generator, disclosed in D6, would find commonality with the application of an epicyclic gearbox of a gas turbine engine. Therefore the relationships between components of the epicyclic gearbox disclosed in D6 would also be familiar to the skilled person.
60. The Requester identifies the difference between the disclosure of D4 and claim 1 of the Patent to lie in the specific numerical values attributed to the individual

component lateral stiffness as recited in claim 1. This is not contested by the Proprietor and I generally agree with the Requester's assessment at this stage. Although D4 does not explicitly relate to a lateral stiffness this property is implied by the configuration of the input shaft and the flex coupling.

61. The Requester identifies a similar difference between D5 and D6 and claim 1 and claim 11 of the Patent. This is contested by the Proprietor. The Proprietor argues that D5 is a generic design manual that has no specific relevance to geared architecture of a gas turbine engine or discloses a relationship between a gearbox support system and a flexible frame of a fan shaft. The Proprietor makes a similar argument in regard to D6
62. The Requester omits to identify the specific difference between D4 and claim 11 of the Patent although, it seems, that a similar reasoning put forward in regard to claim 1 of the Patent is also intended. Again, this is not contested by the Proprietor.
63. I agree with the Proprietor in that the differences between D5 and D6 and the Patent are substantial. However, as previously stated I am of the opinion that D5 and D6 each exemplify the common general knowledge that the skilled person would ordinarily apply in designing a transmission mounting system of a gas turbine engine.

Viewed without any knowledge of the alleged invention as claimed, do those differences constitute steps that would have been obvious to the person skilled in the art or do they require any degree of invention?

64. The Requester argues that the numerical values defined in the claims constitute selection inventions as the claimed range is arbitrary. The Requester relies on an annex of P1 to support their argument, the annex reads;

"Notes:

Lateral spring rates on structural components are something we can measure and enforce.

Film stiffness, spline stiffness, journal bearing stiffness are difficult to interpret (therefore difficult to enforce).

The 11% is arbitrary. Larger is better."

65. The Proprietor refutes this argument and observes that none of the prior art disclose a range of relative stiffness values and therefore the claims cannot be selected from a previously disclosed broader range. The Proprietor further disputes the provenance of P1.
66. The Proprietor additionally argues that the key feature of the claim is that the lateral stiffness of the support and the input coupling are both significantly lower, for example an order of magnitude lower, than the stiffness of the support frame.
67. I am of the opinion that the differences between claim 1 of the Patent and the disclosure of D4, either in isolation or read in light of the common general knowledge as exemplified in D5 and D6, lie exclusively in values attributed to the

relative stiffness of the input coupling and the flexible support, and specifically:

- (i) the input coupling has a lateral stiffness of less than 11% of the frame lateral stiffness, and
 - (ii) the flexible support has a lateral stiffness of less than 11% of the frame lateral stiffness.
68. Similarly, I am of the opinion that the differences between claim 11 of the Patent and the disclosure of D4, either in isolation or read in light of the common general knowledge as exemplified in D5 and D6, lie exclusively in values attributed to the relative stiffness of the input coupling and the flexible support and specifically;
- (i) the input coupling has a lateral stiffness of less than 5% of the gear mesh lateral stiffness, and
 - (ii) the flexible support has a lateral stiffness of less than 8% of the gear mesh lateral stiffness.
69. The phrase "*The 11% is arbitrary. Larger is better*" must be construed in light the whole disclosure. P1 teaches that input coupling lateral stiffness and flexible support lateral stiffness is 11%, or lower, than the frame lateral stiffness therefore when considering the range 0% to 100%, clearly, 100% is not better as at 100% neither the flexible support nor the input coupling would distort relative to the support frame and consequently the problem the invention attempts to solve would not be met. The skilled person would understand that the drafter of P1 intended to instruct the reader that any suitable value within the range <11% would realise the invention although the greater the number, within that range, would be better.
70. Furthermore, based on the material before me, which does not include expert evidence, I am not persuaded that the specific relationships set out in claims 1 and 11 are arbitrary. In my opinion the skilled person in light of the teachings of D4 in isolation, or in combination with the common general knowledge as exemplified in D5 and D6, would not arrive at the invention of claim 1 or claim 11 of the Patent.
71. Therefore in my opinion claims 1 and 11 are inventive.

Opinion

72. I am of the opinion that the Patent does not disclose matter extending beyond that disclosed in the application as filed under section 76 of the Act.
73. I am of the opinion that the specification discloses the invention clearly enough and completely enough for it to be performed by a person skilled in the art under section 14(4) of the Act.

74. On the basis of the evidence put forward regarding documents D4-D6, I am of the opinion that claim 1 and claim 11 of the Patent involve an inventive step under section 3 of the Act.

Sean O'Connor
Examiner

NOTE

This opinion is not based on the outcome of fully litigated proceedings. Rather, it is based on whatever material the persons requesting the opinion and filing observations have chosen to put before the Office.