

HS2 Phase 2b: Crewe – Manchester and West Midlands – Leeds

Guide to the working draft Environmental Statement and working draft Equality Impact Assessment Report

Between 11 October and 21 December 2018 we are carrying out two consultations on HS2 Phase 2b: Crewe – Manchester and West Midlands – Leeds.

In these consultations we are seeking your feedback on:

- **The working draft Environmental Statement** that describes the likely significant effects of building and operating Phase 2b of HS2; as well as proposed ways to avoid, reduce, mitigate and monitor these effects.
- **The working draft Equality Impact Assessment Report** that considers the potential effects of building and operating the railway on groups protected by the Equality Act (2010).



This guide provides an overview of the information we are consulting on and how this is presented across the various documents that make up the working draft Environmental Statement and working draft Equality Impact Assessment Report.

These consultations include new information about the proposals in your area. Please let us know what you think and take this opportunity to influence our plans for the new railway.

For more information please visit www.hs2.org.uk/phase2b



Working draft Environmental Statement

The working draft Environmental Statement (ES) provides a description of Phase 2b and describes the likely significant environmental effects of building and operating the railway; and the measures we propose to avoid, reduce, mitigate and monitor these effects.

The working draft ES is based on a point-in-time assessment in the ongoing development of Phase 2b. The purpose of this consultation is to provide all those affected or interested in the project with an opportunity to review and comment on our initial work to assess the environmental impacts of Phase 2b.

Feedback will be taken into consideration as we further develop of our proposals and finalise the Environmental Statement that will be submitted to Parliament alongside the hybrid Bill.

The working draft ES is made up of the following documents:

Non-technical summary

A summary of the information in the working draft ES including a summary of the significant environmental effects identified to date for each community area.

Glossary of terms and list of abbreviations

This contains an explanation of the terms and abbreviations used throughout the working draft ES.

Volume 1: Introduction and methodology

This provides:

- a description of HS2 Phase 2b, the environmental assessment process and the approach to consultation and engagement;
- details of the permanent features of Phase 2b and general construction techniques;
- a summary of the scope and methodology used to assess the environmental effects;
- an outline of our approaches to mitigation and monitoring; and
- a summary of the alternatives studied.

Finding what you need in a community area report

Each community area report in Volume 2 has the same structure. To help find the information you're most interested in, please use the table of chapter contents below.

1. Introduction	5. Air quality	11. Landscape and visual
2. Overview of the area and description of Phase 2b	6. Community	12. Socio-economics
3. Stakeholder engagement and consultation	7. Ecology and biodiversity	13. Sound, noise and vibration
4. Agriculture, forestry and soils	8. Health	14. Traffic and transport
	9. Historic environment	15. Water resource and flood risk
	10. Land quality	

Similarly, each of the community area map books share the same structure. In each map book you will find a guide to the different types of mapping included and index maps to help you find the specific map you're interested in.

Volume 2: Community area reports and map books

The route has been divided into 28 community areas. This volume contains reports and map books for each area that provides the following information:

- an overview of the area;
- a description of the construction and operation of Phase 2b in the area;
- a summary of the local alternatives considered since the Secretary of State's announcement of the preferred route in July 2017;
- a description of the local environment today, an assessment of the potential environmental impacts, both beneficial and adverse, of Phase 2b and the proposed means of avoiding, reducing or managing the effects; and
- outline proposals for monitoring effects during construction and operation.

The maps relevant for each community area are provided in separate Volume 2 map books.

Two community areas cover the proposed electrification of the Midland Main Line between Clay Cross and Sheffield Midland Station. This work is required to enable HS2 services to connect to Sheffield via Chesterfield. These reports contain less detailed information and do not yet have separate map books because we are at an earlier stage of design and assessment on this section of the route.

Volume 3: Route-wide effects

This describes the effects that are likely to occur at a route-wide scale such as the overall effects of Phase 2b on surface and groundwater bodies.

Volume 4: Off-route effects

This provides an overview of the anticipated off-route works and surrounding environment (where locations are known) together with indicative lists of environmental topics expected to be included in the assessment of off-route works in the ES submitted alongside the hybrid Bill.

Supporting documents

- EIA Scope and Methodology Report: this outlines the scope and methodology adopted for the environment assessment process that will be reported in the Environmental Statement submitted alongside the hybrid Bill.
- Alternatives Report: this describes the evolution of Phase 2b and the reasonable alternatives considered at this stage of the design, at the strategic, route-wide, route corridor and local levels.
- Draft Code of Construction Practice: this sets out the measures and standards that are proposed to help control the potential effects of construction on communities and the environment.

Community areas on the Phase 2b route

The community areas that make up Volume 2 are shown below, from the south on the left to the north on the right.

Western leg

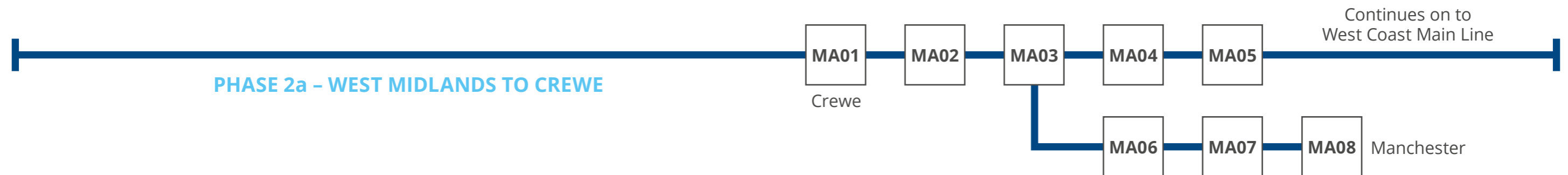

Eastern leg

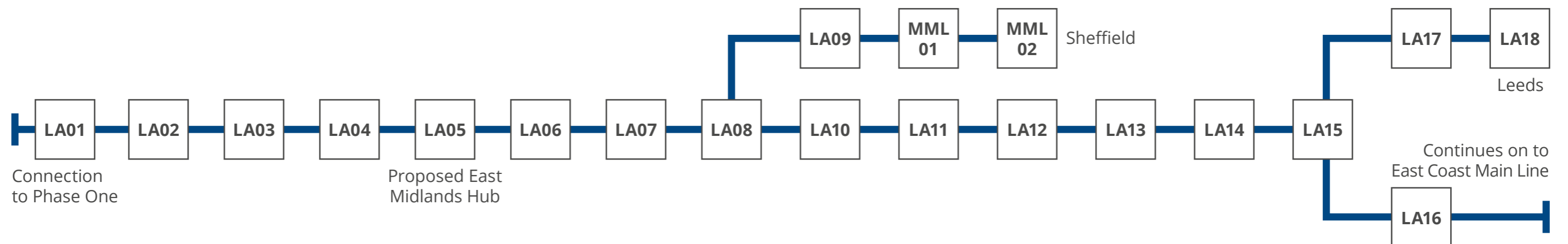

Community area names in full

MA01: Hough to Walley's Green
 MA02: Wimboldsley to Lostock Gralam
 MA03: Pickmere to Agden and Hulseheath
 MA04: Broomedge to Glazebrook
 MA05: Risley to Bamfurlong
 MA06: Hulseheath to Manchester Airport
 MA07: Davenport Green to Ardwick

MA08: Manchester Piccadilly Station
 LA01: Lea Marston to Tamworth
 LA02: Birchmoor to Austrey
 LA03: Appleby Parva to Ashby-de-la-Zouch
 LA04: Coleorton to Kegworth
 LA05: Ratcliffe-on-Soar to Long Eaton
 LA06: Stapleford to Nuthall

LA07: Hucknall to Selston
 LA08: Pinxton to Newton and Huthwaite
 LA09: Stonebroom to Clay Cross
 LA10: Tibshelf to Shuttlewood
 LA11: Staveley to Aston
 LA12: Ulley to Bramley
 LA13: Ravenfield to Clayton

LA14: South Kirkby to Sharlston Common
 LA15: Warmfield to Swillington and Woodlesford
 LA16: Garforth and Church Fenton
 LA17: Stourton to Hunslet
 LA18: Leeds Station
 MML01: Danesmoor to Brierley Bridge
 MML02: Unstone Green to Sheffield Station

Working draft Equality Impact Assessment Report

The working draft Equality Impact Assessment (EQIA) Report considers the potential effects of constructing and operating Phase 2b on groups with protected characteristics. These groups are defined by the Equality Act 2010 as: age, disability, gender reassignment, marriage and civil partnership, pregnancy and maternity, race, religion and belief, sex, and sexual orientation.

The working draft EQIA Report draws on information provided in the working draft ES. This will be updated and submitted as an EQIA Report when the hybrid Bill is deposited in 2020.

The working draft EQIA Report includes:

- a summary of the scope and methodology for the EQIA;
- identification of people with protected characteristics likely to be affected by Phase 2b;
- a route-wide assessment of potential equality effects, taking account of general mitigation measures; and
- an assessment of specific individual effects in the three development areas into which the Phase 2b route has been divided.

The working draft EQIA Report is divided into the following three development areas, each of which covers multiple community areas:

Development Area 1: Crewe to Manchester, covering community areas MA01 to MA08

Development Area 2: Birmingham to Bolsover, covering community areas LA01 to LA08

Development Area 3: Bolsover to Leeds, community areas covering LA09 to LA18

The working draft EQIA Report includes a map book, which sets out the information on protected characteristic groups identified in the report.

Supporting documents

- EQIA Scope and Methodology Report: this outlines the scope and methodology adopted for the equality impact assessment for the EQIA report submitted alongside the hybrid Bill.

Where to find the consultation documents

- All of the working draft ES documents can be found by visiting:
www.gov.uk/government/consultations/hs2-phase-2b-working-draft-environmental-statement-consultation
- All of the working draft EQIA Report documents can be found by visiting:
www.gov.uk/government/consultations/hs2-phase-2b-working-draft-equality-impact-assessment-report-consultation

To request a printed copy of any consultation document, please contact the HS2 Helpdesk using the details at the back of this leaflet.

Reference copies of the consultation documents will also be available at a number of public locations during the consultation and at a series of information events.

Details of both can be found at www.hs2.org.uk/phase2b



How to respond to the consultations

We are seeking your comments on both the working draft ES and working draft EQIA Report. Listed below are all the ways in which you can respond to the consultations.

Working draft Environmental Statement

Online: <https://ipsos.uk/environment2b>

Email: environment2b@ipsos-mori.com

Post: **FREEPOST HS2 PHASE 2B ENVIRONMENTAL CONSULTATION**

Working draft Equality Impact Assessment Report

Online: <https://ipsos.uk/equality2b>

Email: equality2b@ipsos-mori.com

Post: **FREEPOST HS2 PHASE 2B EQUALITY CONSULTATION**

**Both consultations close at 23:45 on 21 December 2018.
Please ensure you send us your comments by then.**

Keeping you informed

We are committed to keeping you informed about work on HS2. This includes ensuring you know what to expect and when to expect it, as well as how we can help.

Residents' Charter and Commissioner

The Residents' Charter is our promise to communicate as clearly as we possibly can with people who live along or near the HS2 route. www.gov.uk/government/publications/hs2-residents-charter

We also have an independent Residents' Commissioner whose job is to make sure we keep to the promises we make in the Charter and to keep it under constant review. Find reports at: www.gov.uk/government/collections/hs2-ltd-residents-commissioner

You can contact the Commissioner at: residentscommissioner@hs2.org.uk

Construction Commissioner

The Construction Commissioner's role is to mediate and monitor the way in which HS2 Ltd manages and responds to construction complaints. You can contact the Construction Commissioner at: complaints@hs2-cc.org.uk

Property and compensation

You can find out all about HS2 and properties along the line of route by visiting: www.gov.uk/government/collections/hs2-property

Find out if you're eligible for compensation at: www.gov.uk/claim-compensation-if-affected-by-hs2

Holding us to account

If you are unhappy for any reason you can make a complaint via the helpline. For more details on our complaints process, please visit our website: www.hs2.org.uk/how-to-complain/

Contact us

If you have any questions about this document, please get in touch.

 **Email** HS2enquiries@hs2.org.uk

 **24/7 freephone** 08081 434 434

 **Minicom** 08081 456 472

Write to

High Speed Two (HS2) Limited
Two Snowhill
Snow Hill Queensway
Birmingham B4 6GA

Website www.hs2.org.uk

Please contact us if you'd like a free copy of this document in large print, Braille, audio or easy read. You can also contact us for help and information in a different language.

HS2 Ltd is committed to protecting personal information. If you wish to know more about how we use your personal information please see our Privacy Notice (<https://www.gov.uk/government/publications/high-speed-two-ltd-privacy-notice>).

HS2