



Defence  
Safety  
Authority



## Safety Investigation Report

RAF BLSA LUGE ACCIDENT - NSI

29 January 2018

Defence Accident  
Investigation Branch



## Defence Accident Investigation Branch

*Enhancing safety through investigation*

The role of the DAIB is to conduct independent safety investigation of accidents and serious incidents to determine causal factors and make targeted recommendations in order to prevent accidents and enhance safety, whilst preserving operational capability.

The primary aim of an accident investigation shall be the prevention of future accidents. It shall not be the purpose of a safety investigation to determine liability nor to apportion blame.

### Conditions of Release

1. This information is Crown Copyright and the intellectual property rights for this report belong exclusively to the Ministry of Defence (MOD). No material or information contained in this report should be reproduced, stored in a retrieval system or transmitted in any form outside MOD establishments except as authorised by the MOD.
2. This information is released by the UK Government to a recipient Government for defence purposes only. It may be disclosed only within the Defence Department of a recipient Government, except as otherwise authorised by the MOD.
3. This information may be subject to privately owned rights.
4. This information is released for safety purposes only.
5. Requests for permission for wider dissemination should be addressed to the DSA at the address below.

© Crown copyright, 2018

For all enquiries:

DSA Sec Comms  
Juniper (Level 0) Wing 1 # 5004  
Neighbourhood 5 Abbeywood North  
BRISTOL  
BS34 8QW  
Tel Civ: [REDACTED]

Email: [REDACTED]



<b>Report Title:</b>	RAF BLSA LUGE ACCIDENT - NSI
<b>Reference:</b>	DAIB/18/003
<b>Issue:</b>	1
<b>Date:</b>	July 18
<b>Authors:</b>	Lt Cdr [REDACTED] (Eng) and WO1 [REDACTED] (Eng)
<b>Reviewed by:</b>	Wg Cdr [REDACTED]
<b>Approved by:</b>	Gp Capt [REDACTED]

**Probability Expressions.**

The use of probability expressions in this Non-Statutory Inquiry (NSI) follows DAIB SOP 514 “Probabilistic Language” Figure 1. The purpose of introducing probability expressions is to facilitate standardised communication of uncertainty in DSA Accident and Incident reporting.

The choice of expression remained a matter of judgement by the Investigation Team and provided an indication of meaning based on common usage and understanding. The terminology should therefore be thought of in terms of relative meaning within the report rather than a precise measurement of probability.

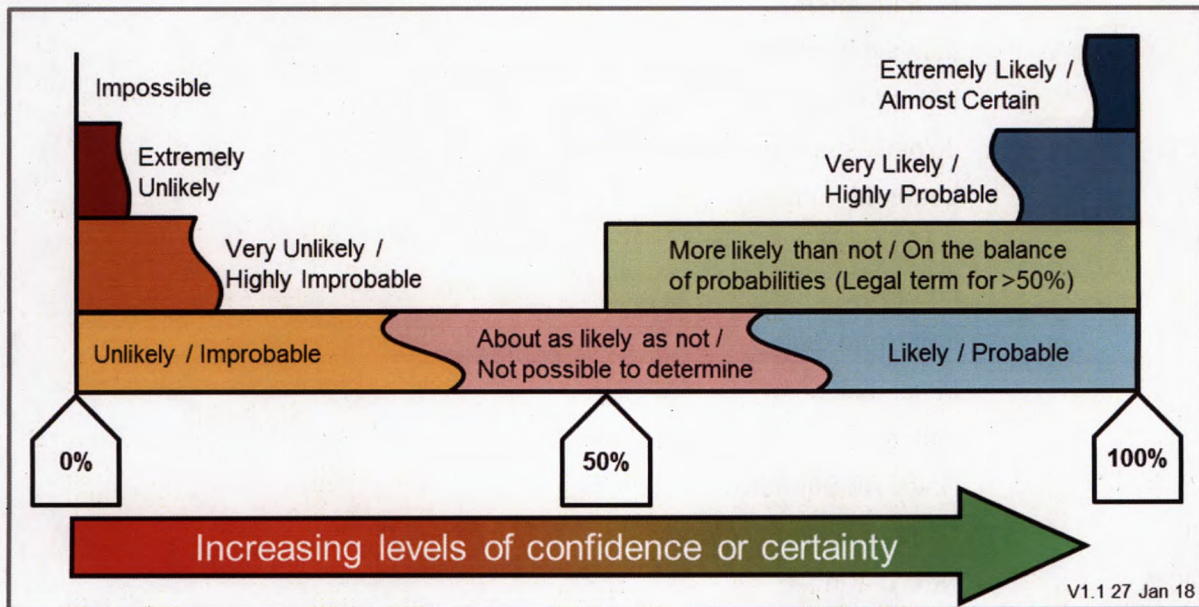

**Figure 1: Probability expressions used in this Non-Statutory Inquiry**

## Glossary

ALARP	As Low As Reasonably Practicable
AO	Administration Order
AOC	Air Officer Commanding
AT	Adventurous Training
BLSA	Bobsleigh, Luge and Skeleton Association
CCTV	Closed Circuit Television
DAIB	Defence Accident Investigation Branch
D COM Ops	Deputy Commander Operations
DTM	Delegated Team Manager
DG DSA	Director General Defence Safety Authority
DRS	Directorate of RAF Sport
EHIC	European Health Insurance Card
EO	Enabling Objectives
FIL	International Luge Federation (Federation Internationale de Luge de Course)
GB	Great Britain
HF	Human Factors
HSAW	Health and Safety At Work Act
HQ	Headquarters
IO	Investigating Officer
IP	Injured Person
JCCC	Joint Casualty and Compassionate Centre
LOA	Letter Of Authority
LoS	Line of Sight
LH	Left Hand
LHS	Left Hand Side
MT	Motor Transport
M	Metres
NAS	Naval Air Squadron
NGB	National Governing Body
NOK	Next of Kin
NSI	Non-Statutory Inquiry
OiC	Officer in Charge
OEM	Original Equipment Manufacturer
PPE	Personal Protective Equipment
PA	Public Address
RAF	Royal Air Force



RA	Risk Assessment
RHS	Right Hand Side
RN	Royal Navy
RP	Responsible Person
SAC	Senior Aircraftman/woman
SME	Subject Matter Expert
SM	Safety Manager
SMO	Senior Medical Officer
SMP	Safety Management Plan
SMS	Safety Management System
SOP	Standard Operating Procedure
SP	Service Person
SQEP	Suitably Qualified and Experienced Person
TM	Team Manager
TRiM	Trauma Risk Management
TO	Training Objectives
UK	United Kingdom
USA	Urgent Safety Advice



## 1 Executive Summary

On 29 Jan 18, a luge sporting incident involving a Service Person (SP) occurred at the Innsbruck Olympia Eiskanal at Igls Austria during the Royal Air Force (RAF) Bobsleigh, Luge and Skeleton Association (BLSA) Novice Ice Championships 18; the accident resulted in the SP receiving a serious head injury. The Defence Accident Investigation Branch (DAIB) deployed 2 investigators to carry out the initial investigation. The Director General of the Defence Safety Authority (DG DSA), upon review of the Triage Report, decided that the DAIB would carry out a Non-Statutory Inquiry (NSI). The Triage Investigating Officer (IO) did not identify any practices which posed a significant or enduring risk to life and, as such, there was no recommended Urgent Safety Advice (USA).

The SP had successfully completed an initial ice-run at the Igls track earlier on 29 Jan 18 and navigated the same section of track without incident and was informally assessed by the RAF BLSA coaching staff as competent to continue with a second ice-run. During the SPs second ice-run the accident sequence commenced when the SP contacted the ice wall in the straight leading into Turn 10. The SP was unable to adequately correct her racing line after the initial impact and subsequently impacted the ice wall a further 3 to 4 times along the straight without making an effective recovery prior to entering Turn 10. Due to a lack of Closed Circuit Television (CCTV) coverage throughout the whole of Turn 10<sup>1</sup> it cannot be confirmed, but is extremely likely, that the SP lost momentum towards the exit of Turn 10 and fell from a height of approximately 4.5 metres (M) impacting the inside of the ice wall on the Left Hand Side (LHS) of the exit<sup>2</sup>. It can be confirmed that the SP departed her sled at this point and impacted her head several times on the ice floor before coming to rest on the track at the entry of Turn 11; it can also be confirmed that the SPs sled came into contact with SPs helmet after she departed the sled<sup>3</sup>.

The DAIB NSI confirmed that there were no technical issues with the SPs sled or Personal Protective Equipment (PPE) but did identify some lifing and servicing issues with the SPs helmet and sled. The cause of the accident was determined as being a combination of loss of sled control by the SP and her inability to successfully execute corrective steering actions prior to entering Turn 10. Contributory factors include the absence of any formalised or assured novice luge training and a lack of a formalised or assured on-ice novice competency assessment, limited knowledge of RAF BLSA safety and assurance policy by the nominated RAF BLSA Luge Team coaches and safety officials, a lack of 2<sup>nd</sup> Party assurance by the Directorate of RAF Sport (DRS) and no 3<sup>rd</sup> Party risk-based assurance by either the RAF Safety Centre, National Governing Body (NGB) or other Front-Line Command (FLC).

The NSI team concluded that it was not possible to determine if the SP received all of the necessary training that would have enabled her to effect the required corrective actions after she encountered a loss of sled control event. The RAF BLSA did not deliver any formalised or assured training or conduct any formalised or documented on-ice competency assessment of the SP prior to this accident. These omissions culminated in the SP entering Turn 10 at a high entry angle

<sup>1</sup> Sun blinds were lowered throughout Turn 10 except for one section within the centre of the turn (Figure 6).

<sup>2</sup> It is not known if the SP suffered a head trauma as a consequence of this impact (Impact Point 6) but the available evidence suggests it is extremely likely that a significant high energy deceleration event occurred at this point and threw the IP from her sled.

<sup>3</sup> Evidence reference - DAIB/18/003/2058.



suffering a loss of forward momentum towards the exit of the turn concluding in a fall from height and subsequent high energy impact with the ice wall.

No formalised training processes or procedures have been established for either the RN, RAF or Army Novice Luge Teams. None of the Single Service Luge Teams have had any formal 2nd Party safety or assurance activities carried out on their delivery of novice luge training. High-Risk Representative sporting activities conducted within the military by novice SP are currently not regulated within the DSA Regulatory Framework. It was confirmed that at least 4 other injuries were sustained during the RAF BLSA Novice Ice Championships 18; none of these additional injuries were reported by the RAF BLSA staff.

In order to address the findings of this NSI, 25 Safety Recommendations have been made to the RAF BLSA, RAF DRS, RAF Safety Centre, Fleet Commander, RAF Deputy Commander Operations (D Com Ops), The Army Sports Control Board and the DSA HQ with the aim of reducing the likelihood of reoccurrence of this type of accident in the military.

**Contents**

1	Executive Summary .....	v
2	Factual Information.....	1
2.1	Introduction .....	1
2.2	RAF BLSA Novice Ice Championships Overview .....	1
2.3	Governance of RAF sport.....	2
2.4	Assurance of the RAF BLSA .....	2
2.5	RAF BLSA Overview .....	3
2.6	RAF BLSA Medical Cover .....	4
2.7	RAF BLSA Luge Team Management .....	4
2.7.1	Luge TM.....	4
2.7.2	Coach 1.....	5
2.7.3	Coach 2.....	5
2.7.4	Coach 3.....	5
2.8	Athlete Selection .....	5
2.9	Novice Athlete Supervision.....	5
2.9.1	Pre-accident Phase .....	7
2.9.2	Accident Phase .....	10
2.9.3	Post-accident Phase .....	15
2.10	Chronology of Events .....	17
3	Equipment.....	18
3.1	Introduction .....	18
3.1.1	Luge Sled Design.....	18
3.1.2	RAF BLSA Luge Equipment .....	18
3.1.3	IP's Luge Clothing .....	23
4	Analysis.....	25
4.1	Introduction .....	25
4.1.1	Available Evidence .....	25
4.1.2	Main Lines of Inquiry .....	26
4.2	Methodology.....	26
4.3	Accident Factors .....	26
4.3.1	Causal Factors .....	26
4.3.2	Contributory Factors.....	27
4.3.3	Aggravating Factors .....	27



4.3.4 Other Factors ..... 27

4.3.5 Observations ..... 27

4.4 Event Management ..... 27

4.5 IP’s Accident ..... 30

4.6 RAF BLSA Assurance ..... 33

4.7 RAF BLSA Luge Training ..... 35

4.8 RAF BLSA Medical Supervision ..... 38

4.9 IP’s Luge Sled ..... 40

4.10 IP’s Luge Helmet ..... 42

4.11 RN and Army Luge ..... 47

4.12 Post Incident Management ..... 48

4.13 Human Factors ..... 49

5 Summary of findings and recommendations ..... 51

5.1 Findings ..... 51

5.1.1 Causal Factors ..... 51

5.1.2 Contributory Factors ..... 51

5.1.3 Other Factors ..... 51

5.1.4 Observations ..... 52

5.1.5 Conclusion ..... 54

5.2 NSI Safety Recommendations ..... 56

5.2.1 Organization ..... 56

5.2.2 Training and Supervision ..... 57

5.2.3 Assurance ..... 58

5.2.4 Equipment ..... 59

6 References ..... 60



**Figures**

Figure 1: Probability expressions used in this Non-Statutory Inquiry ..... ii

Figure 2: Luge Sled..... 6

Figure 3: Innsbruck Eiskanal Igls Austria.....9

Figure 4: IP’s 2nd Ice-Run Impact Points ..... 11

Figure 5: IP Impact Points 3, 4 and 5 prior to entering Turn 10 ..... 12

Figure 6: Turn 10 with mid-section sunblind raised ..... 13

Figure 7: IP Impact Points 6, 7 and 8 on exit of Turn 10..... 14

Figure 8: Luge sled ..... 18

Figure 9: BLSA Luge Equipment Storage Facility Room 1, RAF Halton ..... 19

Figure 10: BLSA Luge Equipment Storage Facility Room 2, RAF Halton ..... 19

Figure 11: Most recent RAF BLSA Sled Service Record ..... 20

Figure 12: IP’s Luge Sled, BLSA Serial Number 1 damage..... 21

Figure 13: Front LH Internal Bridge Attachment Bolt Damage Figure 11 ..... 21

Figure 14: IP’s Helmet (Standard - FIL 2010 050)..... 22

Figure 15: IP’s Helmet Bag and Visor ..... 23

Figure 16: Examples of Luge clothing issued by RAF BLSA (Not IP’s clothing)..... 23

Figure 17: Examples of body armour issued to IP (Not actual IP’s body armour) ..... 24

Figure 18 - Ice wall damage at the exit of Turn 10..... 31

Figure 19: Close up of Figure 18 – Ice wall damage on the inside of the exit of Turn 10 ..... 31

Figure 20: Helmet Classification Areas (Standard - FIL 2010 050)..... 43

Figure 21: IP’s Helmet Damage RHS Upper ..... 44

Figure 22: IP’s Helmet Damage RHS lower ..... 45

Figure 23: Summary of Factors..... 53



## 2 Factual Information

### 2.1 Introduction

Throughout this report all times are LOCAL unless stated. The following information has been established from witness statements and physical evidence gathered during this investigation.

On 29 Jan 18, a luge sporting incident involving a Service Person (SP) occurred at Innsbruck Olympia Eiskanal in Igls Austria during the Royal Air Force (RAF) Bobsleigh, Luge and Skeleton Association (BLSA) Novice Ice Championships 18. The SP was competing in the RAF BLSA Novice Luge event and suffered a serious head injury. Immediately after the accident the SP was tended to by RAF BLSA Coaches, RAF BLSA athletes, Austrian ambulance staff and the Igls Track Manager before being taken to ██████████ Hospital via Air Ambulance. The SP was subsequently aero-medevaced back to the United Kingdom (UK) on █ Feb 18. The SP involved in the accident will be referred to as the Injured Person (IP) from this point onwards.

The IP is a Regular Senior Aircraftwoman (SAC) who attended the RAF BLSA Novice Ice Championships 18 as a Novice luge athlete.

The Defence Accident Investigation Branch (DAIB) deployed 2 investigators to carry out an initial Triage investigation into this incident. The aim of the Triage deployment was to conduct a fact-finding investigation to assist The Director General of the Defence Safety Authority (DG DSA) in determining the most appropriate post incident course of action and to secure vulnerable and perishable evidence. The investigators reviewed the technical aspects of the IP's luge sled and PPE along with the organizational aspects relevant to the command and control of the event at the time in order to identify any urgent safety issues. Based on the Triage Report<sup>4</sup> the DG DSA decided that a NSI conducted by the DAIB was the most appropriate method to investigate this accident. The Triage IO did not identify any practices which posed a significant or enduring risk to life and, as such, there was no recommended Urgent Safety Advice (USA).

### 2.2 RAF BLSA Novice Ice Championships Overview

The RAF BLSA Novice Ice Championships 18<sup>5</sup> were held at the Innsbruck Olympia Eiskanal in Igls Austria (Figure 3) during the period 26 Jan – 12 Feb 18. These championships involved several ice events including a week of novice luge training culminating with a final luge race day conducted on the ice-track at Igls; this was followed by a second week of Inter-Service ice events.

The Ice-Track at Igls is an International Luge Federation (FIL)<sup>6</sup> registered Olympic luge track and is controlled by a Track Manager situated within the Track Control Point (Figure 3). Access to the track is monitored by Closed Circuit Television (CCTV) and a Public Address (PA) system is employed to communicate with athletes and safety officials along its entirety. A traffic light system is employed to indicate that the track is clear before athletes commence their ice-runs. Trackside telephones are situated along the track to enable communication with the Track Manager in an

<sup>4</sup> Evidence reference - DAIB/18/003/2053.

<sup>5</sup> This event aims to promote leadership, teamwork, initiative, discipline, physical fitness and to enhance the reputation of the RAF.

<sup>6</sup> The International Luge Federation is the main international federation for all luge sports.



emergency. Sunblinds are utilised at the Igls ice-track on a number of the bends (Figure 6) to prevent exposed sections of the track ice from melting.

The overall Command and Control of the RAF BLSA Novice Ice Championships 18 was delegated to an Officer in Charge (OiC) with Team Managers (TMs) nominated for individual RAF BLSA ice disciplines. The nominated OiC as detailed within the RAF BLSA Administration Order<sup>7</sup> (AO) did not deploy until the second week; an RAF SNCO was nominated with 2iC responsibilities for the first week. The RAF BLSA AO was issued prior to the Novice Ice Championships 18 detailing the management of individual disciplines and provided safety, medical, PPE, additional equipment lists, personal insurance requirements, travel details and contingency instructions.

Discipline TMs are nominated within the AO, and within the RAF BLSA Safety Management Plan (SMP)<sup>8</sup>, as being responsible for Safety Management within their own sport disciplines and are directed to conduct specific-to-discipline Risk Assessments (RAs) prior to undertaking on-ice activities; 3 RAF BLSA luge coaches were nominated as Safety Officials within the AO and are detailed within this report as Coach 1, Coach 2 and Coach 3. Two Intermediate luge athletes and 14 Novice luge athletes deployed initially to Germany and then to Igls, Austria with the RAF BLSA luge coaching staff.

### 2.3 Governance of RAF sport

Overall governance of UK Armed Forces sport is detailed within JSP 660 (Sport in the Armed Forces) and provides current policy directives<sup>9</sup>. RAF Sport strategy, policy and the governance of day-to-day duty status authorised sport is detailed within AP 3415<sup>10</sup>; these authorised activities are managed and assured from within a 1\* Directorate working directly for Air Officer Commanding 22 (AOC 22 Gp).

### 2.4 Assurance of the RAF BLSA

The RAF DRS is the controlling authority responsible for policy, governance and assurance of RAF sport. The RAF DRS is also responsible for delivering safe and competitive sport and exercises executive responsibility for the control and conduct of all sport undertaken by all of the RAF Sports Associations; the RAF BLSA is one of 50 sports associations<sup>11</sup> under RAF DRS control.

Assurance within RAF sports revolves around the requirement for 1st and 2nd Party internal audits with 3rd Party external audits of the RAF DRS being conducted on a risk based approach either by the appropriate NGB, other Service Commands or the RAF Safety Centre. RAF Sports are categorised by Sport England as either High or Low risk sports with High risk sports mandated to be audited every 18 months within AP 3415 Leaflet 15 Annex A. Sport England is a non-departmental public body under the Department for Digital, Culture, Media and Sport; its role is to build the foundations of a community sport system by working with sport National Governing Bodies (NGB). The RAF BLSA luge discipline has been deemed as a High-Risk Sport.

<sup>7</sup> Evidence reference - DAIB/18/003/2001.

<sup>8</sup> Evidence reference - DAIB/18/003/2002.

<sup>9</sup> JSP 660 V2.1 Mar 18 details single Service regulations for Sport in the UK Armed Forces; BRd51(4) - Sport in the Naval Service, AGAI Vol 1 Chap 5 – Army Sport, AP 3415 – Sport in the RAF.

<sup>10</sup> Evidence reference - DAIB/18/003/2024.

<sup>11</sup> AP3415 Leaflet 15 Annex A.



RAF BLSA 1<sup>st</sup> Party Assurance is mandated to be complied with by annual completion of the RAF DRS Assurance Self-Assessment Questionnaire<sup>12</sup>; 2<sup>nd</sup> Party Assurance is mandated to be conducted by the RAF DRS every 18 months. A 3<sup>rd</sup> Party risk based assurance audit of the RAF DRS, conducted either by the RAF Safety Centre, NGB or other FLC, is also mandated; no periodicities are detailed with AP 3415 for this 3<sup>rd</sup> Party risk based audit.

## 2.5 RAF BLSA Overview

The RAF BLSA is managed by serving and reserve SP who are the enablers for ice sport delivery supported by public and non-public Service funds and are accountable to the Chairman of the RAF Service Sports Board for the delivery of novice luge. Team GB civilian luge coaches have previously been employed by the RAF BLSA to deliver some aspects of luge training during previous RAF BLSA Novice Ice Championships; no Team GB civilian luge coaches were available for the RAF BLSA Novice Ice Championships 18.

The RAF BLSA is accountable to the RAF DRS for the delivery of Bobsleigh, Luge, Skeleton and Natural Luge<sup>13</sup> ice sports disciplines. The RAF BLSA staff act as the Subject Matter Experts (SME) for their sport and select and manage RAF representative teams, including novice teams and provide coaches and safety officials for the Novice Ice Championships.

The RAF BLSA Chairman has been appointed the RAF BLSA Responsible Person (RP) by Letter of Authority (LOA) from the RAF Sports Board and is legally responsible for the duty of care of SPs partaking in all RAF BLSA activities.

The RAF BLSA RP has nominated a Safety Manager (SM) who is responsible for compiling the current RAF BLSA SMP winter season 2018/19<sup>14</sup>. This SMP is a comprehensive document which outlines the roles and responsibilities of the RAF BLSA RP, SM and Discipline TMs and additionally details the Risk Assessment (RA) and medical supervision policy to be complied with by all TMs along with additional information pertaining to RAF BLSA governance and the training of RAF BLSA staff.

The RAF BLSA RP designates RAF BLSA coaching staff as Suitably Qualified and Experienced Personnel (SQEP) if they have participated as a competitor at a Single Service, Combined Service or at a national level. Additional SQEP criteria includes coaching under the mentorship of a SQEP or by officiating at other ice sports events.

The designated TM for the RAF BLSA luge discipline did not deploy to the RAF BLSA Novice Ice Championships 18 due to a mandatory training requirement associated with his primary role and delegated his TM responsibilities to Coach 1. Coach 3 was appointed as the RAF BLSA Luge Kit Manager and Safety Official<sup>15</sup> and Coach 2 was utilised as a coach and Safety Official. No formal National Governing Body (NGB) coaching course exists for luge; the RAF BLSA coaching staff are deemed SQEP<sup>16</sup> by the RAF BLSA Responsible Person (RP) based only on individual luge experience and representation at GB or Inter-Service level.

<sup>12</sup> Evidence reference - DAIB/18/003/2013.

<sup>13</sup> A sister sport to luge but is a totally separate ice discipline.

<sup>14</sup> Evidence reference - DAIB/18/003/2002.

<sup>15</sup> Coaches 1, 2 and 3 were designated as Safety Officials within the AO.

<sup>16</sup> Evidence reference - DAIB/18/003/2040.



The RAF BLSA SM provides discipline TMs with a generic RA covering the general risks involved in moving to and from Ice-Tracks and includes non-track related risks. A requirement for a specific to discipline RA<sup>17</sup> for luge is additionally detailed within the SMP; this specific to discipline RA should be reviewed by the TM on arrival at the designated resort and an additional on-ice RA carried out by the discipline TM prior to any on-ice activity taking place. The RAF BLSA SMP also details individual athlete responsibilities pertaining to personal fitness and medical status.

## 2.6 RAF BLSA Medical Cover

The RAF BLSA SMP requires that the RAF BLSA have trained First Responder personnel<sup>18</sup> and that a Duty-Medic, who is First Responder trained, should be trackside prior to commencement of any RAF BLSA on-ice event.

## 2.7 RAF BLSA Luge Team Management

### 2.7.1 Luge TM

The Luge TM at the time of the accident was a serving [REDACTED] and had been the Luge TM for [REDACTED] years, he has also represented the [REDACTED]. The Luge TM is mandated<sup>19</sup> within the SMP as being responsible for the following:

- Providing an up to date on-ice RA and for their own discipline.
- Ensuring luge equipment is serviced annually and servicing records kept.
- Arranging selection events for potential ice sports athletes.
- Arranging for coaching staff that are SQEP to train athletes.
- Ensuring athletes are instructed on sled care by a SQEP individual.
- Ensuring athletes are not pushed, nor push themselves beyond their individual abilities.
- Ensuring athletes are provided with and use safety and PPE.
- Ensuring sufficient medical supervision is trackside at all times during the on-ice event.
- Liaising with the RAF Sports Board to provide support to athletes with potential for representation at a higher level.

<sup>17</sup> Evidence reference - DAIB/03/003/2012.

<sup>18</sup> An individual that has attended a recognised BTEC level First Responder medical course and has the requisite in-date qualification.

<sup>19</sup> Evidence reference - DAIB/18/003/2002.



### 2.7.2 Coach 1

Coach 1 is a [REDACTED] who has represented the [REDACTED]. Coach 1 was the nominated RAF BLSA Luge TM for the RAF BLSA Novice Ice Championships 18 and had been deemed SQEP by the RAF BLSA RP<sup>20</sup>.

### 2.7.3 Coach 2

Coach 2 is a [REDACTED] who has [REDACTED]. Coach 2 has [REDACTED]. Coach 2 was the first to attend the IP after the accident and delivered initial First Aid. Coach 2 has been deemed SQEP by the RAF BLSA RP.

### 2.7.4 Coach 3

Coach 3 is a [REDACTED] who has [REDACTED]. Coach 3 has [REDACTED]. Coach 3 had been deemed SQEP by the RAF BLSA RP.

## 2.8 Athlete Selection

SPs wishing to attend the RAF BLSA Luge Novice Ice Championships are required to apply directly to the RAF BLSA and complete a questionnaire providing reasons why they should be selected. Each potential novice luge athlete is additionally required to complete a RAF BLSA application form which includes a 200-word pen-picture and requires the individual to identify their personal qualities, attributes, interests and hobbies. The applications are used by the Luge TM as a mechanism for novice luge team selection.

After an initial sift by the Luge TM, individuals are selected to attend a road Luge Taster day<sup>21</sup> at RAF Halton<sup>22</sup>. Individuals who did attend the Luge Taster day were assessed by the Luge TM and Coaches 1 and 3 on their wheeled luge abilities and physical coordination. The novice luge athletes who did not attend this taster event were selected on the information contained within their application forms only.

Eight additional SP who attended the RAF BLSA Luge Novice Ice Championships 18 as either Novice or Intermediate athletes provided evidence to support this NSI, none of these SP witnessed the IP's accident; Novice 1 was the IP's roommate.

## 2.9 Novice Athlete Supervision

Each RAF BLSA discipline TM is deemed responsible for novice safety and supervision whilst competing or training at RAF BLSA authorised events. Prior to departure successful novice applicants including the IP were met at RAF Halton on 26 Jan 18 by Coaches 1, 2 and 3 and were measured for and issued with PPE<sup>23</sup>; novice luge athletes were also measured for, and allocated with, specific RAF BLSA luge sleds.

<sup>20</sup> Evidence reference - DAIB/18/003/2010.

<sup>21</sup> The RAF Halton Luge Taster day is not a mandatory RAF BLSA novice luge training event.

<sup>22</sup> Not all of the selected luge novice athletes who deployed to Igls in Jan 18 with the RAF BLSA attended this taster day.

<sup>23</sup> Helmets, visors, gloves, body armour, luge suits and boots were issued to the novice athletes by the RAF BLSA Coaches.



## On-ice Novice Athlete Training

The novice Luge Team were first moved by Service MT to a refrigerated starting gate practice slope<sup>24</sup> at Königssee Germany in order to gain some on-ice luge experience. During this event the RAF BLSA coaches demonstrated how to mount and dis-mount the luge sled (see Figure 2) and explained how to steer the sled. Pressure applied to the left Bow will steer the luge sled to the right; pressure applied to the right Bow will steer the luge sled to the left. Steering can also be achieved by utilising the sled handles and coordinated body weight distribution.

The novice athletes were briefed by all 3 Coaches on how to steer the sled including the technique of maintaining “form”<sup>25</sup> with shoulders fully back whilst gripping the sled handles and using their legs to steer. All novice luge athletes completed several runs down the starter slope and were given informal verbal feedback on individual technical ability and areas for improvement. On completion of the Königssee event personnel were moved by Service MT to Igls Austria arriving on Sun 28 Jan 18.

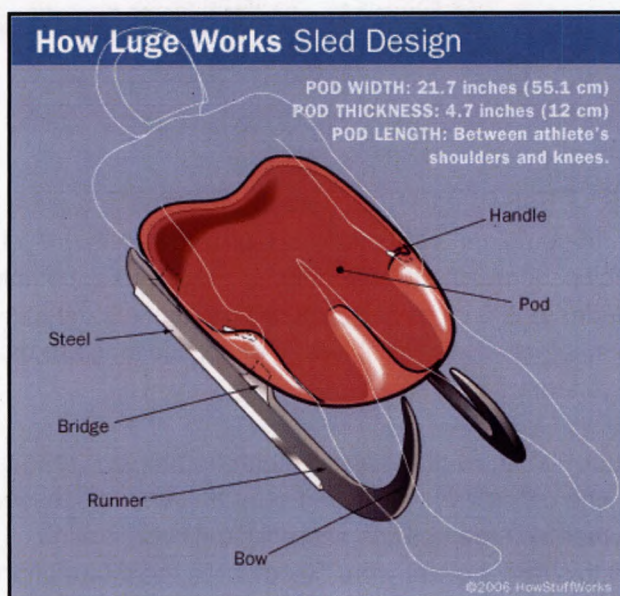

**Figure 2: Luge Sled**

## Environmental Conditions

The environmental conditions at the time of the accident, and for the period leading up to the event were benign. The weather was clear and sunny for the entire period with no reported visibility limitations. The temperature was 1.2°C during the Ice-Track walk conducted on the morning of 29 Jan 18 and increased to between 5.3 and 7.2°C at the time of the accident. The wind varied slightly between 1 and 6 mph with decreasing humidity 84.6 - 61.1%<sup>26</sup>. The clear and sunny conditions on the day of the accident required the track management to deploy sunblind covers over exposed elements of the track to prevent direct sunlight melting exposed sections of the track.

<sup>24</sup> The starter slope was a 30m straight section of Ice-Track designed to replicate an Ice-Track starting slope.

<sup>25</sup> A luge term for maintaining a streamlined position with shoulders back to enable more sled control.

<sup>26</sup> Evidence reference - DAIB/18/003/2036.



### 2.9.1 Pre-accident Phase

The RAF BLSA Luge Team arrived at Igls Austria on Sun 28 Jan 18; an initial Ice-Track walk was conducted on the afternoon of 28 Jan 18 to familiarise the novice athletes with the Igls Ice-Track (Figure 3). The RAF BLSA coaches provided a verbal overview of the sections of track to be used during the novice luge event; no on-ice activities took place on this day.

On 29 Jan 18 at approximately 0730 the IP had breakfast with the other novice luge athletes; the team then departed for the Igls Ice-Track arriving at approximately 1020. A further Ice-Track walk was conducted led by Coach 1 assisted by Coach 2 and Coach 3. This was a more detailed track walk utilising Team GB luge racing lines and information from the FIL which informed the athletes of the most appropriate cornering positions and the ideal luge lines to take when navigating the nominated section of the track between the designated start and finish line (Figure 3). The nominated novice start point was the designated Igls Ice-Track children's start point and was deemed by Coach 1 to be the lowest point at which novice luge athletes should commence their initial track runs.

All novice athletes were then moved to a heated changing room adjacent to the designated start point to individually conduct safety checks on their luge equipment and PPE under the supervision of the RAF BLSA Coaches and the 2 Intermediate athletes<sup>27</sup>. These safety checks were briefed to the novice athletes by the RAF BLSA coaches based on previous luge experience and were not detailed within a procedure or checklist.

Prior to commencing the on-ice activity a safety brief was delivered by Coach 1, this was a verbal safety brief which included the necessary actions required when mounting and dismounting the track and included the designated track locations for Coach 2 and Coach 3; it was not possible to determine whether this safety brief included a loss of sled control element. Two-way radios were employed by the coaches to enable communication with each other prior to, during, and after each of the novice luge ice-runs; an additional radio was provided to the novice athletes within the changing room.

Coach 2 was positioned next to the track straight (Figure 4) between Turns 9 and 10 and was employed to monitor athlete "form" out of Turn 9 through the following straight and into Turn 10. Coach 2 made notes on each of the athlete's ice-runs and provided feedback to the athletes and Coach 1 and 3 via radio communication. Coach 3 was positioned at the designated track finish line to aid athletes out of the track and monitored the novice ice-runs by means of a large track TV screen that displayed live CCTV footage. Coach 1 was located at the designated start point and conducted the final pre-run safety checks; this is a final check of all of the athletes PPE and equipment and a final assurance check that the novice athlete remained content to commence the track ice-run. All of the novice luge athletes including the IP were instructed by Coach 1 to remove their helmet visors for their initial ice-runs, this is based on RAF BLSA normalised practice; the NGB does not mandate an athlete needs to finish a luge ice-run with a visor attached to the helmet. Visors were issued to all RAF BLSA novice athletes as designated luge equipment prior to departure from RAF Halton.

---

<sup>27</sup> Intermediate athletes had not been detailed within the AO as RAF BLSA staff and had not been deemed SQEP by the RAF BLSA RP.



At approximately 1200 on 29 Jan 18 the luge novices including the IP conducted their first ice-runs; this involved navigating a number of straights and completing several turns including Turns 8 to 14 of the Igls Ice Track before arriving at the designated finish (Figure 3). A Start List Form had been provided by Coach 1 to ensure the Track Manager was aware of the athlete nominal list and running order.<sup>28</sup> The Start List Form also requires a coach signature to confirm all athletes have appropriate personal insurance before commencing their track ice-runs.

Coach 1 received verbal confirmation over the PA from the Track Manager that the track was clear and checked that the track light was set to green; a positive confirmation was also received by Coach 1 from each athlete before commencing their individual ice-runs.

All luge novices completed their initial runs successfully; Coach 1, 2 and 3 conducted debriefs utilising notes made during individual athlete runs and provided each novice with a verbal summary of their ice-run performance along with suggested technique adjustments prior to their 2nd ice-runs. Coach 1, 2 and 3 identified that the IP, and several other novice athletes, had made contact with the track wall on a number of occasions during the initial ice-runs and stated in interview<sup>29</sup> that this is not unusual; Coach 3 also stated that the IP was a "foot steerer"<sup>30</sup>. Coach 1 in consultation with Coach 2 and 3 deemed the IP sufficiently competent to conduct a 2nd ice-run.

---

<sup>28</sup> Evidence reference - DAIB/18/03/2009 - Example only as original document could not be identified.

<sup>29</sup> Evidence reference - DAIB/18/003/6008 and DAIB/18/003/6010.

<sup>30</sup> An athlete who prefers to steer the sled using their legs on the sled Bows as opposed to shifting their bodyweight to impart luge sled steering.



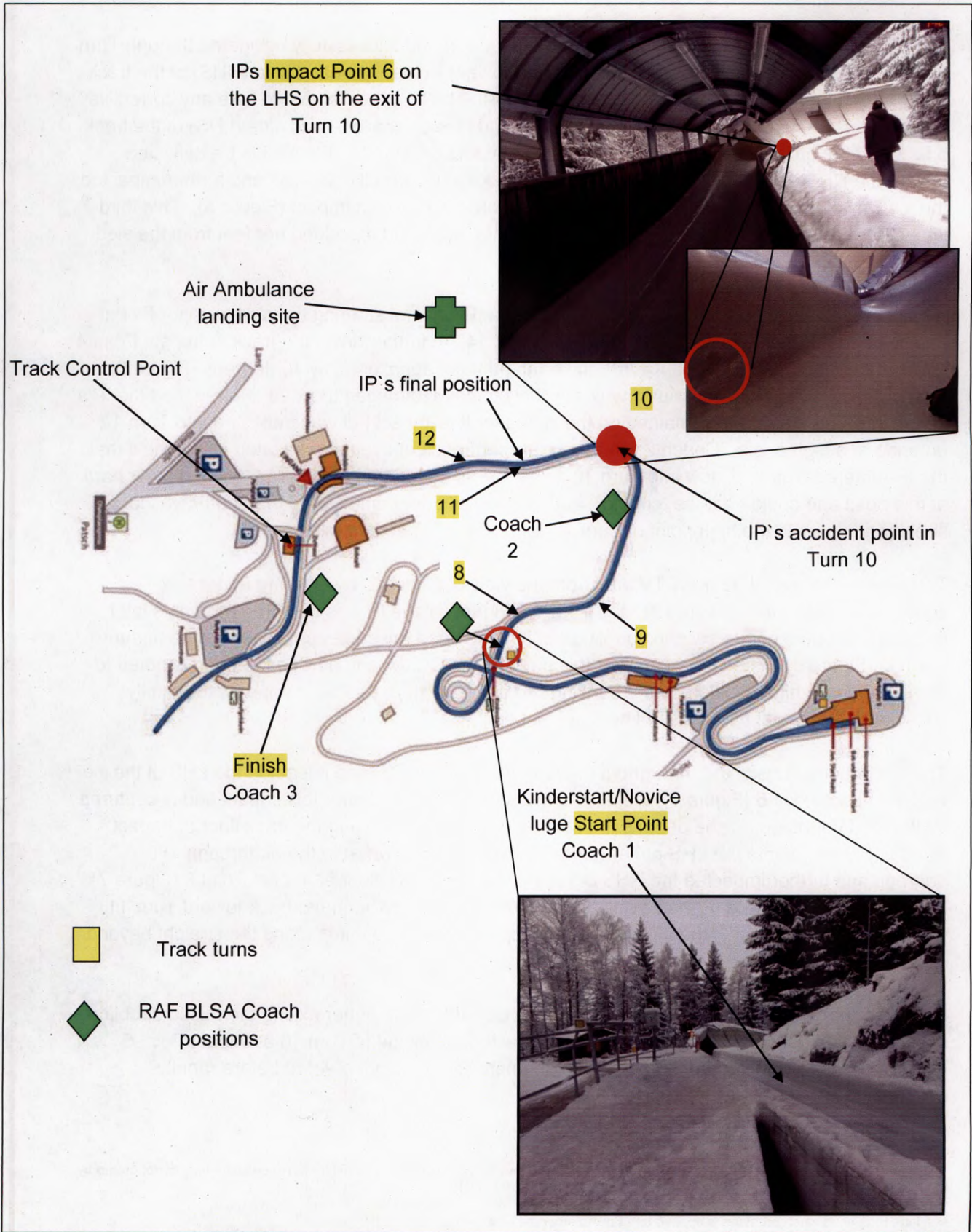

Figure 3: Innsbruck Eiskanal Igls Austria



## 2.9.2 Accident Phase

At 1258 on 29 Jan 18 the IP commenced her 2nd ice-run and successfully navigated through Turn 8 into Turn 9. On the exit of Turn 9 the IP began to veer to the right-hand side (RHS) of the track and glanced the ice wall at Impact Point 1 (Figure 4). The IP appeared not to take any corrective action at this point and glanced the ice wall a second time on the left-hand side (LHS) of the track a further 9.3m on at Impact Point 2. This second impact caused the IP's sled to be deflected toward the RHS of the track; the IP appeared not take any corrective actions and further impacted the ice wall at Impact Point 3 approximately 28m from the previous impact (Figure 5). This third impact further exacerbated the IP's position within the track and dislodged her feet from the sled Bows.

It has been established from CCTV footage that the IP was not steering the sled with her feet at this point and further impacted the LHS of the track 14.7m further down the track at Impact Point 4 at a speed of approximately 40 Km/h<sup>31</sup> and at an angle of approximately 70 degrees (Figure 5). Impact Point 4 was a violent impact which is likely to have damaged the sled and reduced the IP's speed into Turn 10; the IP remained on the sled after this impact but was deflected into Turn 10 entering at a high angle. Coach 2 witnessed this sequence of events and stated in interview that the IP "entered high and slow into Turn 10"<sup>32</sup>; he further stated that the IP was trying to steer hard at this point and could hear ice "cutting"<sup>33</sup> and the sled skidding" and stated that the IP was last seen heading up to the high point of Turn 10, well off the expected racing line.

The IP was lost by the track CCTV, and from the view of Coach 2, by entering under the sunblinds<sup>34</sup> which were lowered around Turn 10 (Figure 6); the IP was captured moments later through one of the centre section sunblinds which had been raised at approximately the mid-turn position (Figure 5). The IP was seen at this point by the CCTV, and by Coach 2, and is noted to be at an usually high position on the banking of Turn 10 (Figure 6); the IP appears to be fully conscious throughout this phase of her accident run.

The IP continued unsighted throughout the remainder of Turn 10 and impacted the LHS of the ice wall at Impact Point 6 (Figure 7); the IP was thrown from her sled after this impact and is captured by the CCTV footage as she departs the sled before further impacting the track floor at Impact Point 7 (Figure 7) onto the LHS of her head. The IP then rolls whilst in the air through 180 degrees and further impacted the RHS of her head on the track floor at Impact Point 8 (Figure 7). After this final impact the IP then continued to slide down the track on her back toward Turn 11 with her sled behind her<sup>35</sup>; the IP came to rest approximately two thirds along the straight beyond Turn 10<sup>36</sup>.

Based on the IP's trajectory into Turn 10 and the CCTV footage of her exiting the raised sunblind section it is almost certain that the IP further impacted the inside of Turn 10 at Impact Point 5 (Figure 5) before climbing up the ice wall to an approximate height of 4.5m before rapidly descending into the ice wall at Impact Point 6.

<sup>31</sup> Distance travelled from entry to Turn 9 to Impact Point 6 – 146 meters in 13 seconds; this estimated speed was also corroborated by the Igls Track Manager in interview. Evidence reference - DAIB/18/003/6013.

<sup>32</sup> Evidence reference - DAIB/18/003/6003.

<sup>33</sup> A luge term used when pressure is applied to a Bow to steer the sled.

<sup>34</sup> Sunblinds are employed throughout the track to prevent exposed track ice melting due to direct sunlight.

<sup>35</sup> Evidence from 1710 NAS confirms that the IPs sled and Helmet came into contact once the IP had departed the sled during this phase of the accident.

<sup>36</sup> It appears from the CCTV footage that the IP was unconscious as she slid down the straight after Impact Point 8.



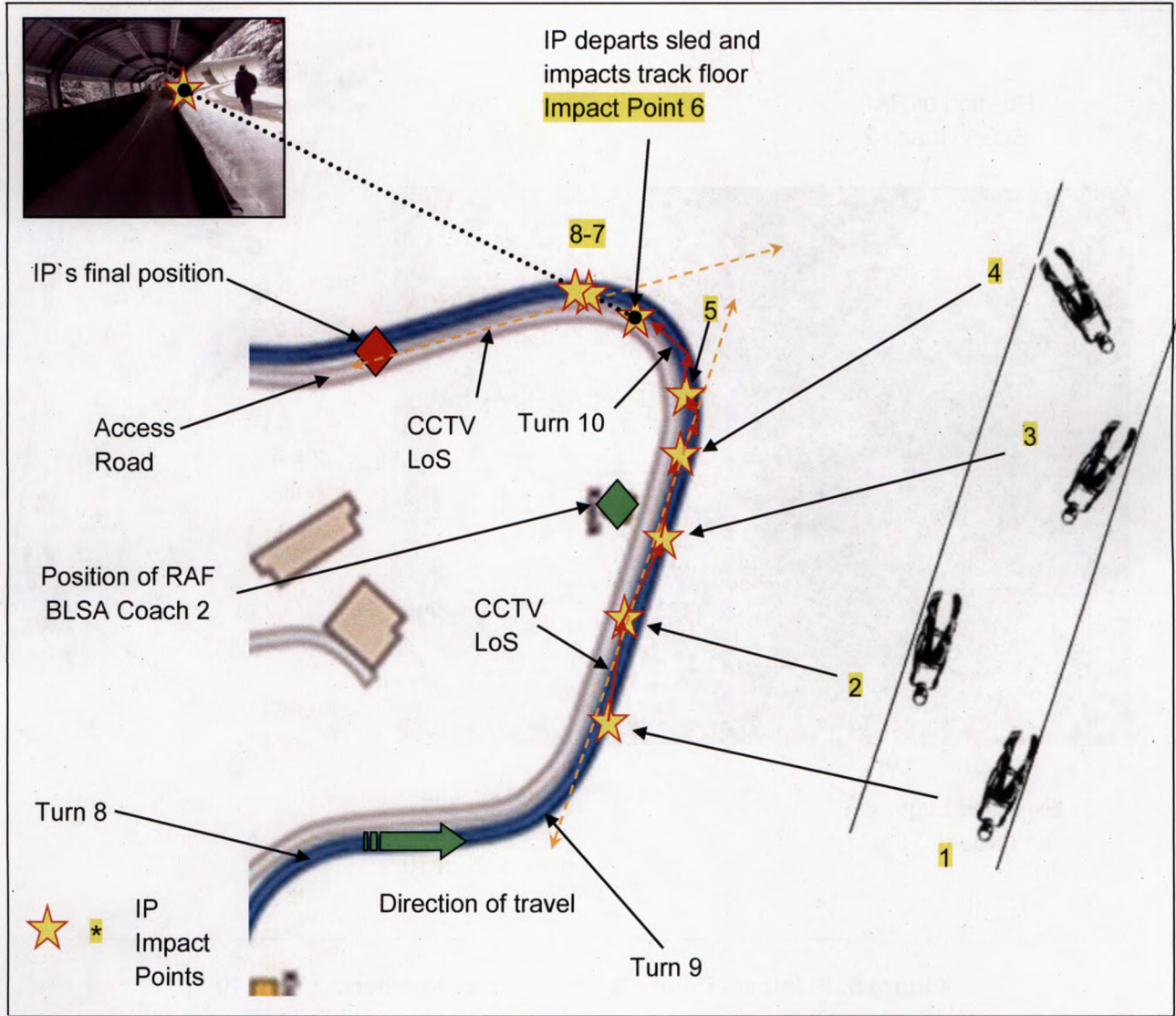

Figure 4: IP's 2nd Ice-Run Impact Points



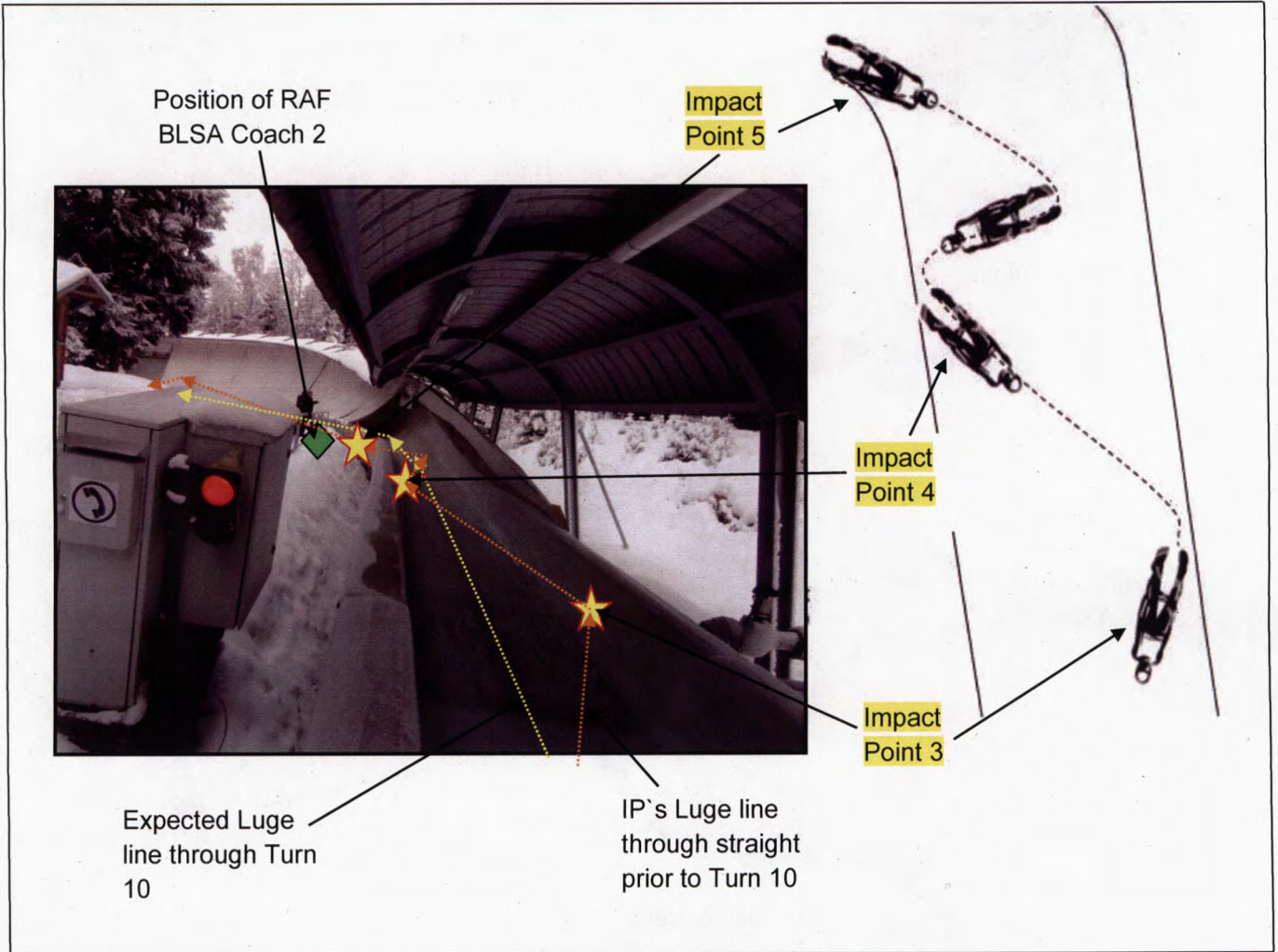

Figure 5: IP Impact Points 3, 4 and 5 prior to entering Turn 10



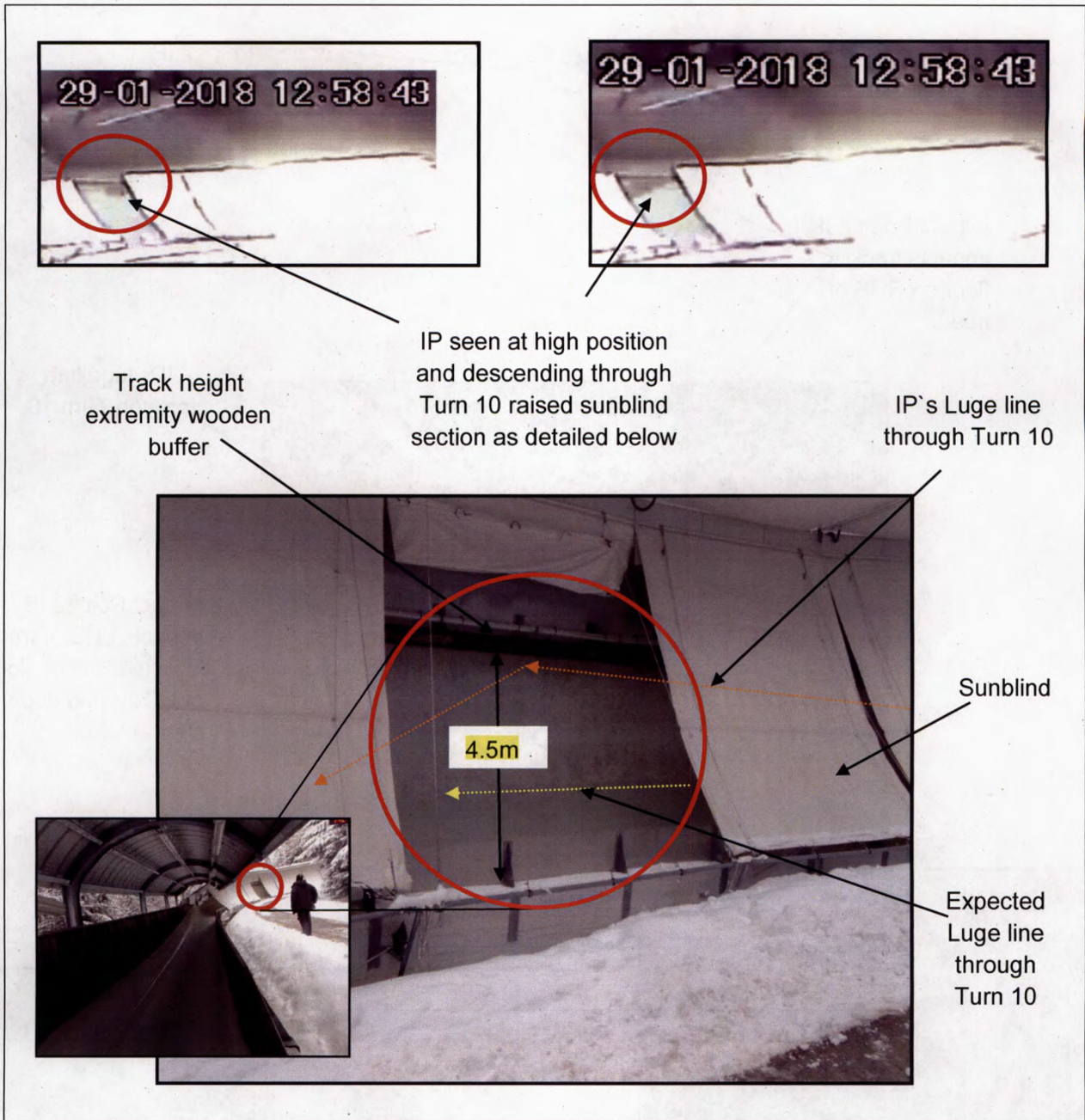

Figure 6: Turn 10 with mid-section sunblind raised



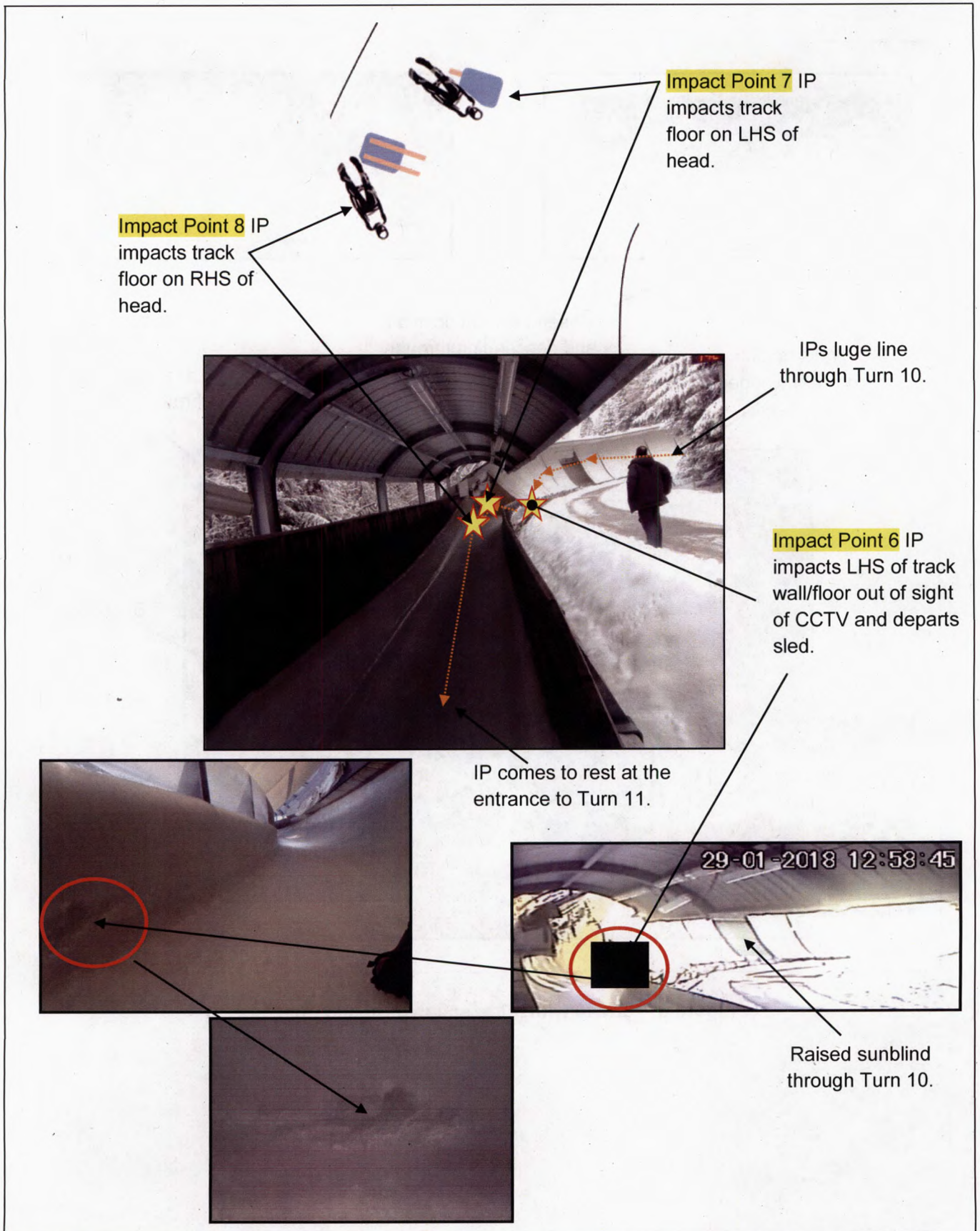

Figure 7: IP Impact Points 6, 7 and 8 on exit of Turn 10



The following additional personnel witnessed the post-accident phase and were actively involved in tending to the IP prior to the arrival of the Austrian paramedics.

### **RAF BLSA Bobsleigh Coach**

The RAF BLSA Bobsleigh Coach is a serving SNCO who was employed by the RAF BLSA as a Coach and Safety Official for the RAF BLSA Bobsleigh Team. The RAF BLSA Bobsleigh Coach was at the Igls Ice-Track preparing to conduct bobsleigh ice training on the afternoon of 29 Jan 18. The RAF BLSA Bobsleigh Coach was not employed by the RAF BLSA Luge Team in any medical or safety capacity on the day of the IP's accident.

### **RAF Doctor**

The RAF Doctor is a serving Flt Lt and was a novice RAF BLSA Bobsleigh athlete who was at the Igls Ice Track preparing to conduct bobsleigh ice training later that day; the RAF Doctor was not employed by the RAF BLSA in any medical capacity.

### **2.9.3 Post-accident Phase**

The Igls Track Manager witnessed the IP's accident via CCTV from the Track Control Room and immediately called for coach assistance over the PA; he subsequently set all track lights to red and ran to the scene with a First Aid kit and blanket.

Coach 2 heard the PA call for assistance and was the first individual to tend to the IP. He approached the IP and called her name seeking a response, he confirmed there was no movement from the IP and had no reaction to his verbal commands; he stated in interview<sup>37</sup> that he believed the IP was either unconscious or fatally injured. Coach 2 then called for additional help utilising his radio and began immediate First Aid. He confirmed that the IP was breathing and her eyes were open. He stated that the IP had one dilated pupil and one pinpointed pupil and that there were no other obvious signs of physical injury; he confirmed that the IP's helmet remained on and was secure.

The RAF BLSA Bobsleigh Coach also responded to the PA announcement and ran to the scene from the bottom of the track. On arrival she assisted Coach 2 in providing C spine neck support and additional First Aid<sup>38</sup>. The Track Manager arrived and noted the IP's unconscious state and called the Austrian emergency services<sup>39</sup>, he then provided the IP with a blanket.

The RAF Doctor also responded to the PA call and arrived at the scene of the accident just after the RAF BLSA Bobsleigh Coach but before the Austrian emergency services. The RAF Doctor provided further medical assistance confirming that the IP was breathing and additionally stated<sup>40</sup> that she suspected the IP had sustained a serious head injury. The RAF Doctor also stated in interview that the initial actions undertaken by Coach 2 and the RAF BLSA Bobsleigh Coach were all adequate.

<sup>37</sup> Evidence reference - DAIB/18/003/6008.

<sup>38</sup> The RAF BLSA Bobsleigh Coach was not a designated RAF BLSA First Responder for the novice luge event but had previously completed a First Responder course unrelated to the RAF BLSA; her First Responder qualification had lapsed.

<sup>39</sup> Two Austrian ambulance teams attended the scene.

<sup>40</sup> Evidence reference - DAIB/18/003/6005.



Austrian paramedics arrived at the accident site at approximately 1315 and assessed that the IP needed immediate hospital treatment and requested an air ambulance. A [REDACTED] and an [REDACTED] were attached to the IP by the paramedics; the RAF Doctor stated<sup>41</sup> that the IP was also [REDACTED].

Coach 3 also responded to the PA call and on arrival witnessed that Coach 2 and the RAF BLSA Bobsleigh Coach were administering First Aid. Coach 3 took charge of removing the IP's sled from the track.

Coach 1 remained at the designated start point with the other novice luge athletes and asked several of the remaining novice athletes to provide assistance to the Austrian paramedics in recovering the IP from the track; this was done on a stretcher with the IP being moved initially along the track and then lowered over the side of the track into a snow-covered field and carried to the Air Ambulance landing site (Figure 3).

Coach 3 attended the local hospital with the IP and gave a statement<sup>42</sup> to the Austrian police; Coach 1 informed the RAF BLSA SM and Luge TM<sup>43</sup> of the incident and provided the IP's passport and EHIC details to the hospital. The RAF Doctor liaised with the UK Military Aeromed team and visited the IP in hospital, JCCC were notified and the IP's NOK informed by Coach 1; Coach 1 additionally requested the deployment of a Trauma Risk Management (TRiM) Team to support the RAF BLSA athletes post the accident.

---

<sup>41</sup> Evidence reference - DAIB/18/003/6005.

<sup>42</sup> This statement was not located by the NSI team.

<sup>43</sup> RAF BLSA SM and Luge TM were not in Igls Austria at the time of the accident.



## 2.10 Chronology of Events

Sec to Impact (a)	Time (b)	Event (c)	Remarks (d)
28 Jan 18	1400	Initial Track walk	Initial Track walk conducted to familiarise novice athletes with the sections of the Igls ice-track to be navigated.
29 Jan 18	0730	Breakfast	IP had breakfast with the other novice athletes.
29 Jan 18	1000	Move to Innsbruck Olympia Ice-Track	Transport by road to ice-track.
29 Jan 18	1020	2nd Ice-Track walk	This track walk utilised FIL and Team GB track notes providing novices with the preferred luge lines to take.
29 Jan 18	1100	Preparation and equipment check	Equipment and safety checks completed by novice athletes under guidance of RAF BLSA staff and Intermediate athletes.
29 Jan 18	1200	IP 1st run	IP successfully completed her 1st Ice run.
29 Jan 18	1258	IP 2nd run	IP was nominated to be the 4th athlete to conduct 2nd ice run.
29 Jan 18	1259	IP Accident	IP suffered a serious head injury post high energy impact with ice wall.
29 Jan 18	1300*	Paramedics called	Paramedics called by On Duty Track Manager.
29 Jan 18	1315*	Paramedics arrive scene	2 local ambulances attended scene.
29 Jan 18	1345*	Air Ambulance to Hospital	Paramedics called for an Air ambulance; IP subsequently airlifted to local hospital in [REDACTED].

\* Times approximate



## 3 Equipment

### 3.1 Introduction

The IP's sled, helmet and visor were issued by the RAF BLSA and recovered by the DAIB Triage team and transferred to the NSI team. After an initial inspection these items were transferred to 1710 Naval Air Squadron (NAS) Structural Materials Investigation team for a further detailed inspection and analysis of the accident damage<sup>44</sup>.

#### 3.1.1 Luge Sled Design

The design specifications for luge sleds are detailed in the International Luge Regulations - Artificial Track<sup>45</sup>. Each sled comprises of several component parts; the main components of the sled are the left and right runners<sup>46</sup>, steels, pod seat and bridges (Figure 8). The runners are made of fibreglass and are the main steering mechanism of the sled. Two steels are mounted on the runners which are designed to be the only sled components in contact with the ice at their inner edges. The front and rear bridges are made of steel and attach each runner to the pod. The pod is made from fibreglass and is the platform on which the athlete lies feet first; the pod also incorporates a handle on either side of the pod for the athlete to hold on to.

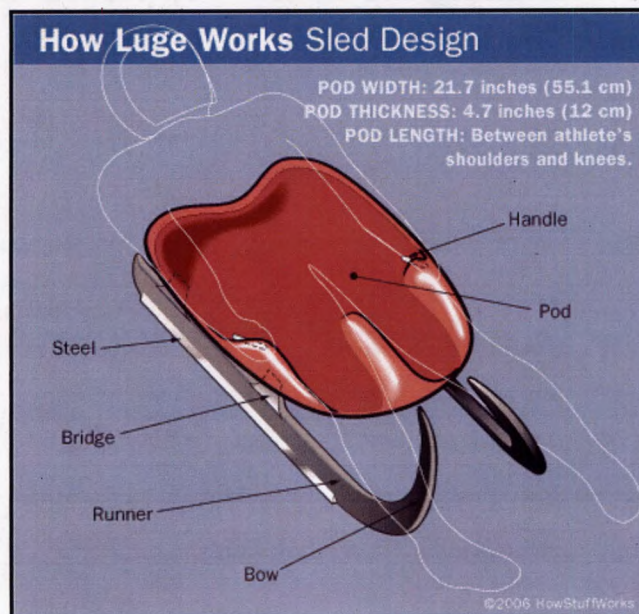

Figure 8: Luge sled

#### 3.1.2 RAF BLSA Luge Equipment

The equipment used by the RAF BLSA novice athletes had been stored at RAF Halton within an allocated storage facility. This area has heating and lighting and is controlled by the Luge TM and Coach 3.

<sup>44</sup> 1710 NAS Technical Report is detailed at Enclosure 2.

<sup>45</sup> Reference: <http://www.fil-luge.org/en/rules/rules-artificial-track>.

<sup>46</sup> The sled runner ends are sometimes referred to as Kufens or Bows.



The storage facility consists of 3 rooms; the first contains helmets and clothing (Figure 9) the second contains the RAF BLSA luge sleds (Figure 10) with a third room used for fitting of equipment and general administration.



Figure 9: BLSA Luge Equipment Storage Facility Room 1, RAF Halton



Figure 10: BLSA Luge Equipment Storage Facility Room 2, RAF Halton

### 3.1.2.1 IP's Luge Sled

The sled issued to the IP was built by a Latvian company 'Fiberglass Ltd' who also supply other products for luge. The IP's sled was built to FIL technical guidelines in terms of structure, weight and dimensions. There is no fixed standard and any changes are guided by the required race performance of the sled<sup>47</sup>. The IP's sled had been stored at RAF Halton in the RAF BLSA luge equipment store prior to the Novice Ice Championships 18.

### IP's Sled Luge Fitment

The IP was sized to and allocated with RAF BLSA luge sled Serial Number 1 by the RAF BLSA coaching staff prior to departing RAF Halton. The associated servicing record for sled Serial Number 1 is detailed at Figure 11<sup>48</sup>.

<sup>47</sup> Reference e-mail - 20180425-UK Military LUGE Build/Maintenance Information - DAIB/18/003 2042.

<sup>48</sup> Evidence reference - DAIB/18/003/7003. This details the name of the athlete nominated with sled Number 1 in 2015.



SLED SERVICE 26-11-2015						
NUMBER	NAME	CUFFIN BOLT	X	TOE	HEXAGON	CENTRE BOLT (REMARKS)
1		✓	✓	✓	✓	1/2mm
2		✓	✓	✓	✓	1/2mm M@ 3 <sup>00</sup> ○
3		✓	✓	✓	✓	1/2mm F@ 4 <sup>00</sup> ○
4		✓	✓	✓	✓	1/2mm SPNS.
5		✓	✓	✓	✓	> 2mm Sp. SPNS.
6		✓	✓	✓	✓	1/2mm Sp. 4 TO 10 RUN.
7	MASSIVE	✓	✓	✓	✓	1/2mm 4 TO 10 RUN.
8		✓	✓	✓	✓	TOE
9		✓	✓	✓	✓	< 2mm Sp. 8 TO 2 <sup>00</sup> RUN.
10	WHEELED	✓	✓	✓	✓	> 1/2mm Sp. 4 TO 10 RUN.
11		✓	✓	✓	✓	SLED
12		✓	✓	✓	✓	> 1/2mm Sp. 4 TO 10 RUN.
13						
14		✓	✓	✓	✓	1/2mm Sp. (M@ 6 <sup>00</sup> )
15		✓	✓	✓	✓	1/2mm Sp. (M@ 6 <sup>00</sup> )
16		Steels	to	be	done.	
17		✓	✓	✓	✓	1/2mm (M@ 12 <sup>00</sup> Sp. 1st)
18		✓	✓	✓	✓	1/2mm (M@ 4 <sup>00</sup> )
19		✓	✓	✓	✓	1/2mm (M@ 4 <sup>00</sup> )
20		✓	✓	✓	✓	2mm Sp. 3 ○
21		✓	✓	✓	✓	1/2mm Sp. M@ 12 <sup>00</sup> ○
22		✓	✓	✓	✓	2mm M@ 6 <sup>00</sup> ○
23		✓	✓	✓	✓	1/2mm 1@ 12 <sup>00</sup> ○
24		✓	✓	✓	✓	1/2mm 1@ 9 <sup>00</sup> ○

Figure 11: Most recent RAF BLSA Sled Service Record

A brief description of the coding used for sled servicing by Coach 3 is detailed below<sup>49</sup>:

- **Number** – Identifier of individual luge sled.
- **Name** – Senior athlete to whom the sled is allocated to.
- **Cuffin [Kufen] Bolt** – A check of the bolt that attaches the runner to the bridge.
- **X** - A check of the 12 bolts that attach the pod fabric holding the back bridge in Place.
- **Hexagon** – Check of the Allen key bolts that hold the steels onto the runner.
- **Toe** – This is a measure of the convergence of the steels between the front and back bridge.
- **Centre bolt remarks** – This is a check of the centre bolt. The “M” is cast on the bolt and is used as a marker for the position of the bolt; in this case it is the 3 O’clock position. The “hexagon” again details that this is an Allen key receptacle [as opposed to a flat head receptacle]. This centre bolt holds the front bridge in place and affects the degree of steering available.

None of the RAF BLSA luge sleds were specifically nominated as novice sleds and have been allocated to other members of the RAF BLSA luge team for other events prior to the Novice Ice Championships 18.

<sup>49</sup> Evidence reference - DAIB/18/003/2033.



### IP's Luge Sled Damage

The IP's sled sustained damage to the LH Bow and LH bridge during the accident (Figure 12); there is no evidence that there was any unserviceability with the IP's sled prior to the accident. The IP's sled had functioned as expected during her initial ice-run at Igls and there is no evidence to suggest that the IP reported any defects prior to her 2nd ice-run.

The luge sled has suffered a number of impacts; it is not possible to determine more than general directions of force which caused the damage to the internal surface of the composite runner (Figure 13)

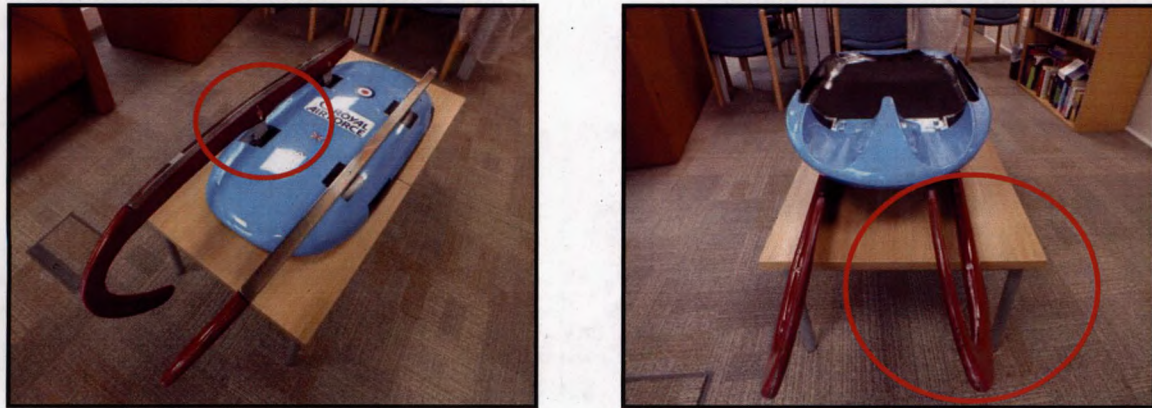

Figure 12: IP's Luge Sled, BLSA Serial Number 1 damage

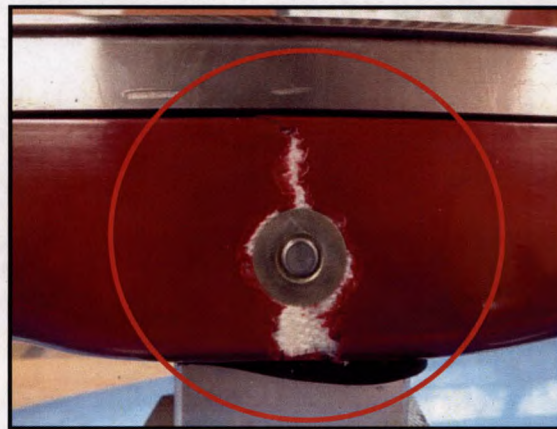

Figure 13: Front LH Internal Bridge Attachment Bolt Damage Figure 11



### 3.1.2.2 IP's Helmet

There are a number of build standards of luge helmets which vary dependant on the date of manufacture. The helmet issued by the RAF BLSA to the IP was annotated with an FIL 2010 standard<sup>50</sup> sticker.

Figure 14 illustrates a number of impact marks on the IP's helmet<sup>51</sup>, the largest concentration of which is seen in the vicinity of the RHS of the helmet. Tape has been added (Figure 14) by RAF BLSA Coaches to various areas of the helmet. The Luge TM stated<sup>52</sup> this is used as a sacrificial layer in order to prolong helmet life. The IP's helmet also incorporated a modification using a 50 cent Euro coin taped to the front centre (Figure 14). Coach 3 stated<sup>53</sup> that this modification was incorporated by the RAF BLSA and was improvised to prevent the visor from misting up and was normal practice within the RAF BLSA<sup>54</sup>.

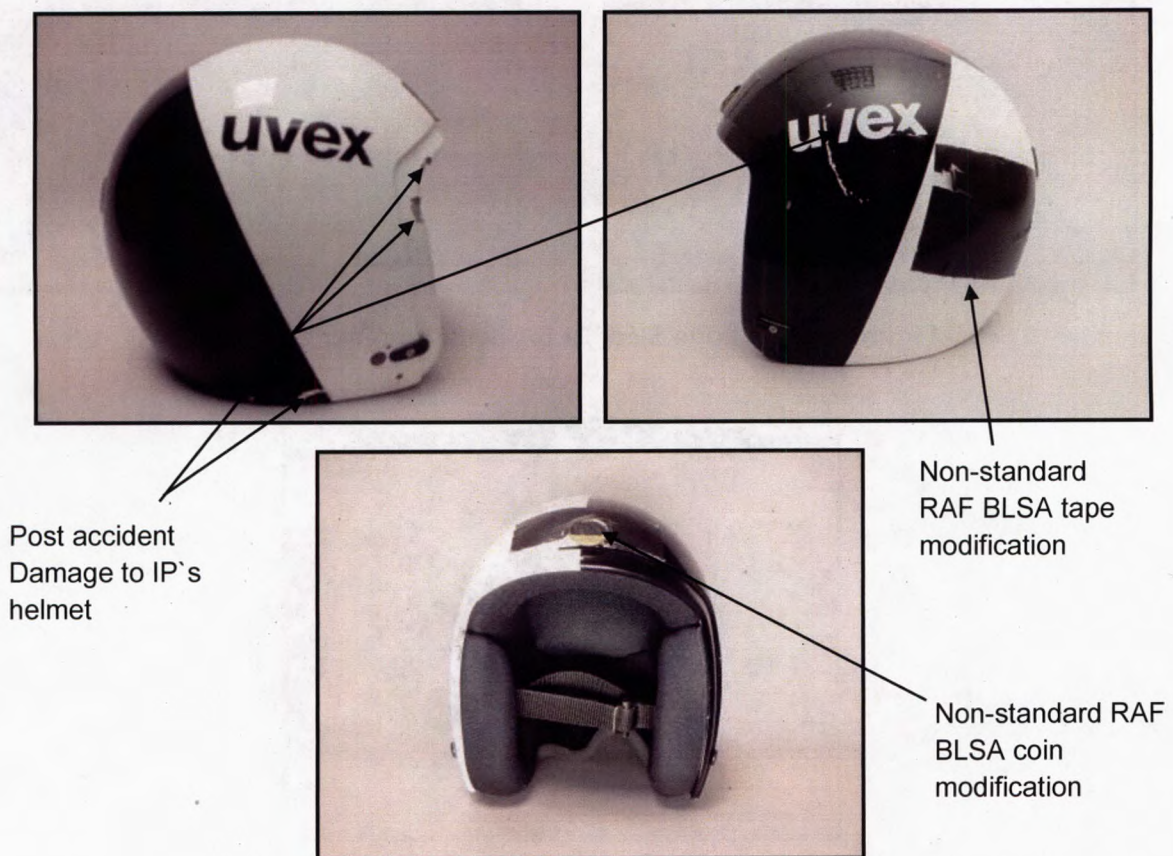

Figure 14: IP's Helmet (Standard - FIL 2010 050)

The IP's luge helmet has a visor<sup>55</sup> that is designed to cover the athletes face just below the chin (Figure 15). This visor is certified to the 'Ski goggle' standard and provides the same function; its

<sup>50</sup> Standard BS EN 1077:2007 - Evidence reference DAIB/18/003/2025.

<sup>51</sup> The damage to the IP's helmet has been assessed by 1710 NAS, the technical report is detailed at Annex B; Evidence reference DAIB/18/003/2058.

<sup>52</sup> Evidence reference DAIB/18/003/6007.

<sup>53</sup> Evidence reference DAIB/18/003/6009.

<sup>54</sup> The NSI team identified other RAF BLSA helmets that had been modified in a very similar way during a visit to the RAF BLSA luge equipment store at RAF Halton.

<sup>55</sup> 1710 NAS identified that the IP's visor was not compatible with the helmet issued to the IP. Evidence reference DAIB/18/003/2058.



design purpose in relation to the helmet is aerodynamic<sup>56</sup>. The IP was not wearing the helmet visor when the accident occurred as directed by Coach 1; Coach 1 stated<sup>57</sup> in interview that this is normal practice for RAF BLSA novice luge athletes.

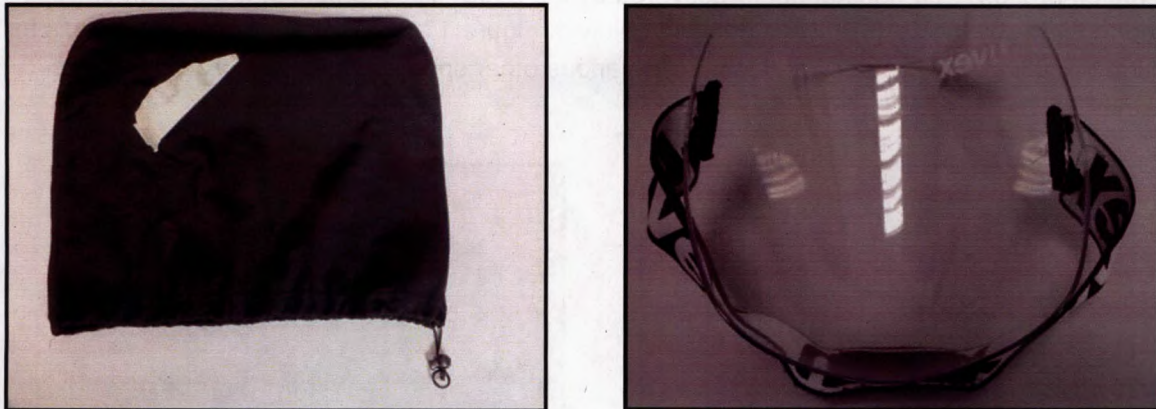

Figure 15: IP's Helmet Bag and Visor

### 3.1.3 IP's Luge Clothing

The luge clothing worn by the IP was retained in the casualty evacuation process and has not been recovered by the DAIB. An example of the luge clothing issued to the IP is detailed below at Figure 16. The IP was instructed by the RAF BLSA Coaches to wear a secondary layer of clothing below the racing suit as its design is to maximise speed and is not designed for comfort or athlete protection; this was considered by the RAF BLSA coaches as more important in the training environment. The IP wore RAF BLSA issued luge boots, but it is unclear as to whether the IP wore issued luge gloves or if personal gloves were used, both were permitted by the RAF BLSA coaches.



Figure 16: Examples of Luge clothing issued by RAF BLSA (Not IP's clothing)

<sup>56</sup> UVEX e-mail query - Evidence reference DAIB/18/003/2034.

<sup>57</sup> Evidence reference DAIB/18/003/6010.



### IP's Body Armour

The body armour issued by the RAF BLSA, and worn by the IP, was retained in the casualty evacuation process and has not been recovered by the DAIB. An example of the equipment issued to the IP by the RAF BLSA is detailed below at Figure 17. These are not bespoke items for the luge discipline and are designed for use in various other sports such as Motorcycling or Ice-Hockey.

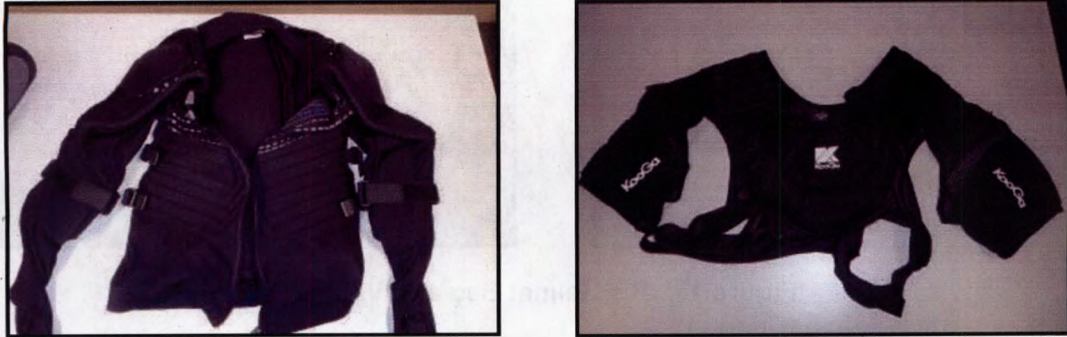

Figure 17: Examples of body armour issued to IP (Not actual IP's body armour)



## 4 Analysis

### 4.1 Introduction

The following section of this report details the analysis of the evidence available to the DAIB. The chronology of events illustrates a timeline of key events from commencement of the IP's 2nd ice-run through to the IP coming to rest before Turn 11.

#### 4.1.1 Available Evidence

The NSI team visited the accident site in Igls Austria, the RAF BLSA equipment store and the RAF DRS at RAF Halton. The NSI team conducted interviews with, or corresponded with, the RAF BLSA RP, SM, Luge TM, RAF BLSA coaching staff, some of the novice and intermediate athletes<sup>58</sup> who attended the RAF BLSA Novice Ice Championships 18, the Igls Track Manager and RAF DRS staff.

The RN and Army Luge TMs were additionally interviewed to ascertain a broader organizational view of the management of the luge discipline within the military. The NSI team were unable to interview the IP due to her injuries.

Athletes who attended the RAF BLSA Novice Ice Championships 18 were contacted along with the UK Luge NGB and FIL; previous interviews conducted as part of the DAIB Triage deployment were also used as evidence<sup>59</sup>.

Available evidence included:

- Statements from or interviews with:
  - RAF BLSA Responsible Person
  - RAF BLSA Luge TM
  - RAF BLSA Safety Manager
  - RAF BLSA Coach 1
  - RAF BLSA Coach 2
  - RAF BLSA Coach 3
  - RAF Doctor
  - RAF BLSA Bobsleigh Safety Official
  - Igls Track Manager
  - RAF DRS SO2 Policy
  - RAF DRS SO3 Assurance
  - Novice 1
  - Novice 2
  - Novice 3
  - Novice 4

<sup>58</sup> Not all of the novice athletes responded to the NSI teams request for information. The RAF BLSA AO did not have an accurate list of novice athlete attendees; some of the SP nominated within the AO did not attend the Ice Championships 18. None of the novice or intermediate luge athletes who did respond to the DAIB witnessed the IP's accident.

<sup>59</sup> This included interviews with the RAF Doctor and RAF BLSA Bobsleigh Coach, Novice 1 and Coaches 1, 2 and 3.



- Novice 5
  - Novice 6
  - Intermediate 1
  - Intermediate 2
  - RN Luge TM
  - Army Luge TM
  - NGB for luge
  - FIL
- 
- A HF report produced by RAFCAM.
  - A technical report produced by 1710 NAS.
  - Defence Intelligence and Fusion Centre support with CCTV footage.
  - RAF BLSA AO, RAF BLSA SMP, RAF BLSA RAs and luge equipment servicing documentation.
  - RAF BLSA 1st Party assurance documents and e-mails.
  - RAF DRS audit schedule and previous RAF BLSA audit reports<sup>60</sup>.
  - RN Luge Policy documents.
  - Army Luge SMP and Policy documents.
  - Luge equipment OEM e-mails.

#### **4.1.2 Main Lines of Inquiry**

The Original Equipment Manufacturer (OEM) was consulted regarding the lifing, maintenance and servicing of the IP's luge sled and helmet, including the visor. The RAF BLSA were also consulted regarding novice luge training techniques, processes, procedures, Risk Management, supervision, 1<sup>st</sup> Party assurance, personnel safety and organizational management. The RAF DRS were consulted regarding 2<sup>nd</sup> and 3<sup>rd</sup> Party assurance of the RAF BLSA luge discipline; the UK NGB for luge were also contacted regarding training standards for luge coaching staff.

There was no evidence of technical failure with the IP's sled or PPE; HF, supervisory and organizational factors involved in this accident were the main lines of inquiry. SME advice was sourced from The FIL and the UK NGB for luge.

#### **4.2 Methodology**

The DAIB Triage investigation<sup>61</sup> discounted any USA and a structured approach was taken by the NSI team to establish the HF and organizational aspects of this accident.

#### **4.3 Accident Factors**

##### **4.3.1 Causal Factors**

Causal Factors are defined as factors which, in isolation or in combination with other factors and contextual details, led directly to the accident.

---

<sup>60</sup> No 2<sup>nd</sup> Party audit had been conducted on the RAF BLSA luge discipline

<sup>61</sup> Evidence reference - DAIB/18/003/2053.



#### 4.3.2 Contributory Factors

Contributory Factors are defined as factors which made the accident more likely.

#### 4.3.3 Aggravating Factors

Aggravating Factors are defined as factors which made the accident outcome worse.

#### 4.3.4 Other Factors

Other Factors are defined as factors which were none of the above but were noteworthy in that it may cause or contribute to future accidents.

#### 4.3.5 Observations

Observations are defined as factors that were not relevant to the accident but worthy of consideration to promote better working practices.

#### 4.4 Event Management

SP attending the RAF BLSA Novice Ice Championships 18 were detailed within the AO as being on duty during all travel, training, racing and supervised coaching sessions. Fit to participate certificates were required to be completed by the selected athletes; the Luge TM stated<sup>62</sup> that these certificates were not received as the AO was late being issued and the requirement was missed. The Luge TM additionally stated that he had requested verbal confirmation from each of the selected athletes on their fitness to deploy.

The AO additionally detailed the nominated OiC and 2iC for the RAF BLSA Novice Ice Championships 18 who were designated as being responsible for the Command and Control of the whole event<sup>63</sup>; the OiC did not deploy until the 2nd week of the Novice Ice Championships 18 but was detailed explicitly within the AO as the JCCC PoC for the whole event. The AO also detailed the Luge TM as being the dedicated TM for the novice luge event at Igls, the AO does however detail that this TM responsibility can be delegated<sup>64</sup> to a Deputy TM.

The RAF BLSA Luge TM did not deploy to the RAF BLSA Novice Ice Championships 18 and delegated his responsibilities to Coach 1. The Luge TM confirmed<sup>65</sup> that no formal face-to-face handover took place but did confirm that a number of e-mails and social media messages were exchanged with Coach 1 regarding the delegation of responsibilities. Coach 1 stated<sup>66</sup> that the AO covering this event was issued late; in interview none of the RAF BLSA Coaches were familiar with the content of the RAF BLSA SMP and stated that the AO was the primary RAF BLSA policy document which detailed their responsibilities for the event.

The NGB for luge does not mandate, or provide, a luge coaching course. NGB coaches are granted their luge coach status based on their experience only<sup>67</sup>. Civilian GB luge coaches have

<sup>62</sup> Evidence reference - DAIB/18/003/6007.

<sup>63</sup> 26<sup>th</sup> Jan-12 Feb 18.

<sup>64</sup> Evidence reference - DAIB/18/003/2001.

<sup>65</sup> Evidence reference - DAIB/18/003/6007.

<sup>66</sup> Evidence reference - DAIB/18/003/6002.

<sup>67</sup> Evidence reference - DAIB/18/003/2040.



been employed by the RAF BLSA on previous Novice Ice Championships to coach novice athletes however this is not mandated within RAF BLSA policy as a prerequisite or a mandated requirement prior to conducting novice coaching. None of the GB luge coaches were available to attend RAF BLSA Novice Ice Championships 18.

RAs<sup>68</sup> had been produced by the RAF BLSA for luge prior to the Novice Ice Championships 18; these RAs were not comprehensive and did not cover all potential hazards associated with on-ice luge activities. A loss of sled control hazard was not identified and “no specific to resort” RA was produced prior to conducting novice training at the Igls resort. A “specific to discipline” RA is mandated within the SMP which should be reviewed by the discipline TM to take into account specific track conditions and when signed and dated is the authority for the on-ice activity to go ahead at the planned venue; Coach 1 stated<sup>69</sup> that he was not aware of this RA requirement but was aware of the generic RA for luge produced by the RAF BLSA.

**The NSI concluded that:**

The RAF BLSA details the policy that defines the responsibilities and actions of all SP organizing and participating in competitive or development Ice Sports including luge within their SMP. The Health and Safety at Work Act 1974 and Duty of Care principles detailed within DSA 01 have been adopted by the RAF BLSA to manage Risk and Safety. The RAF BLSA additionally mandate compliance with the regulations set by the UK NGB for luge. The RAF BLSA SMP provides an amplification of the policy detailed within both High and Mid-level policy<sup>70</sup> documents.

No formal training had been undertaken by Coaches 1, 2 or 3 as no luge coach training exists at the NGB level. No additional formal coaching courses have been provided by the RAF BLSA to their coaching staff. SQEP for each of the RAF BLSA coaches has been endorsed by the RAF BLSA RP based only on their individual luge experience and representation at RAF or GB Luge Team level. Coaches 1, 2 and 3 have not completed any additional coaching or mentoring courses in support of their roles within the RAF BLSA. Team GB and FIL notes of the preferred novice race-lines were utilised by the RAF BLSA coaches to brief the novices; these have not been formally endorsed by Team GB or the FIL for novice training.

There is no evidence that the RAF BLSA “specific to discipline” RA<sup>71</sup> was reviewed on arrival at Igls as required by the RAF BLSA SMP. Coach 1 mandated<sup>72</sup> that all of the novice luge athletes should remove their visors prior to conducting initial on-ice activities; the specific to discipline RA was not amended to reflect this decision and the RAF BLSA Chairman was not notified as required by the BLSA SMP. Coach 1 stated<sup>73</sup> that he did not review the specific to discipline RA and did not conduct or certify any resort specific RAs as mandated within the SMP.

There is no evidence to suggest that the IP was not fit to deploy however no fit to attend certificate was completed by the IP or by the other novice athletes due to the late issue of the AO.

---

<sup>68</sup> Evidence reference - DAIB/18/003/2012.

<sup>69</sup> Evidence reference - DAIB/18/003/6002.

<sup>70</sup> JSP 660; DSA 01; AP 3415.

<sup>71</sup> Evidence reference - DAIB/18/003/2012.

<sup>72</sup> Evidence reference - DAIB/18/003/6010.

<sup>73</sup> Evidence reference - DAIB/18/003/6002.



Due to a lack of any formal training for the RAF BLSA Coaches and lack of assurance of the Luge TM delegation process the mandated RAs were not reviewed and the RAF BLSA RP was not informed of the decision to remove the novice athlete's visors.

The lack of any formal training given to Coaches 1, 2 and 3 by the RAF BLSA and the limited knowledge of RAF BLSA safety and assurance policy by Coaches 1, 2 and 3 are considered to be **Contributory Factors**.

The absence of the OiC for the initial week, the luge TM delegation to Coach 1, the unavailability of any GB luge coaches to attend RAF BLSA Novice Ice Championships 18 and the lack of a specific to resort RA for luge could collectively contribute in making a future accident more likely and are considered by the NSI as **Other Factors**.

**Safety Recommendation – The RAF BLSA RP should review all RAF BLSA Risk Assessments in order to ensure all hazards associated with novice luge activities have been identified and mitigated including the removal of visors.**

**Safety Recommendation – The RAF BLSA RP should review the policy, adherence and assurance of the Specific to Discipline and Specific to Resort Risk Assessment procedures as mandated within the RAF BLSA SMP.**

**Safety Recommendation – The RAF BLSA RP should formalise and assure the RAF BLSA Luge Team Manager delegation process.**

**Safety Recommendation – The RAF BLSA RP should introduce a process for ensuring all RAF BLSA staff are fully conversant with RAF BLSA policy detailed within the RAF BLSA SMP.**

**Safety Recommendation – The RAF BLSA RP should review the SQEP policy for RAF BLSA Coaches in conjunction with the RAF DRS and consider uplifting the RAF BLSA Coaching qualifications to include DSAT comparable coaching and mentoring qualifications in order to ensure all novice athletes receive appropriate on-duty training.**

**Safety Recommendation – The RAF BLSA RP should review the use of Team GB and FIL Ice-track notes used to brief luge novices and should seek official endorsement from the luge NGB for their continued use.**



#### 4.5 IP's Accident

Novice 1 was the [REDACTED] during the RAF BLSA Novice Ice Championships 18 and [REDACTED]; Novice 1 had never attempted luge before and did not attend the RAF BLSA luge Taster Day at RAF Halton. Novice 1 stated<sup>74</sup> that the IP was in good spirits the night before the accident and had not consumed any alcohol; she also stated that all of the luge novices were apprehensive but excited. Novice 1 additionally stated that the Ice-Track at Igls was a significant jump from the starter gate slope at Konigssee Germany and stated that she and other luge novices would have preferred to conduct their 1st ice-runs lower down the Ice-Track.

Novice 1 confirmed that the IP felt confident on the day of the accident and that she expected the IP to do well as she had witnessed the IP's ability at the starter gate at Konigssee Germany. Novice 1 did not communicate with the IP after the 1st ice-run at Igls on 29 Jan 18.

Prior to conducting her 2nd ice-run the IP had left the heated changing room and was assisted by Coach 1 and 2 in completing some warm-up exercises. Coach 1 and 2 both confirmed in interview<sup>75</sup> that the IP seemed confident and that she had volunteered to go first on the 2nd ice-run; Coach 1 randomly selected the IP to be the 4th athlete to conduct the 2nd ice-run. The first 3 athletes<sup>76</sup> completed their 2nd ice-runs without incident.

Coach 2 witnessed a majority of the IP's 2nd ice-run, including her initial impacts, from his allocated track position (Figure 5). Coach 2 also witnessed the IP's entry line and speed into Turn 10 and her racing line through the open sunblind section of the ice-track (Figure 6).

Coach 2 stated in interview<sup>77</sup> that he was concerned when he witnessed the IP enter Turn 10 as he knew from experience that the IP was travelling too slow and was too high to carry the turn and expected the IP to descend hard from height into the exit of Turn 10, he additionally stated that he was expecting the IP to have an incident on the exit of Turn 10. Coach 2 further stated that he heard a heavy impact in the area close to the exit of Turn 10 and recollected the Track Manager making an announcement over the PA calling for a coach to attend an incident at Turn 11<sup>78</sup>.

During a subsequent visit to the Igls ice-track the NSI Team identified a ground witness mark, (Figure 18) in the proximity of Impact Point 6 which was the IP's high energy impact point on the LHS of the track on the exit of Turn 10; this area was not highlighted during the Triage investigation.

<sup>74</sup> Evidence reference - DAIB/18/003/6017.

<sup>75</sup> Evidence references - DAIB/18/003/6008, DAIB/18/003/6010.

<sup>76</sup> These athletes included Intermediate 1 and Intermediate 2.

<sup>77</sup> Evidence reference - DAIB/18/003/6008.

<sup>78</sup> The IP slid down the track straight after the accident and came to rest at the entry of Turn 11.



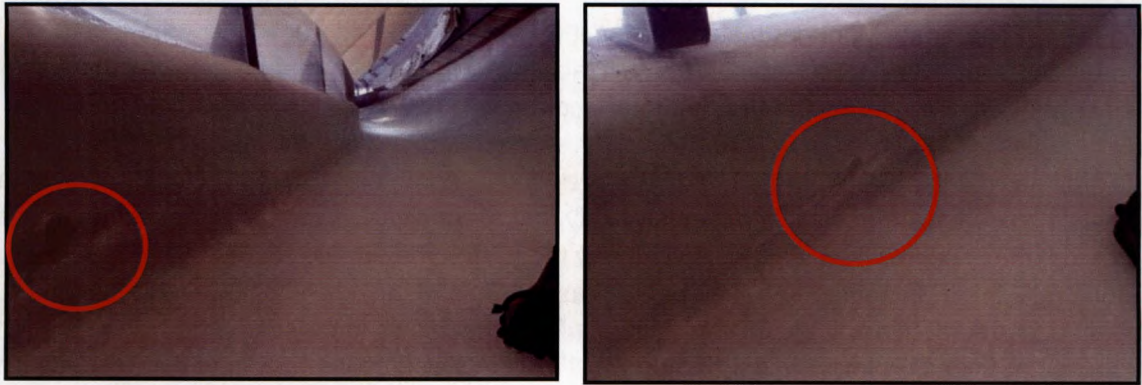

Figure 18 - Ice wall damage at the exit of Turn 10

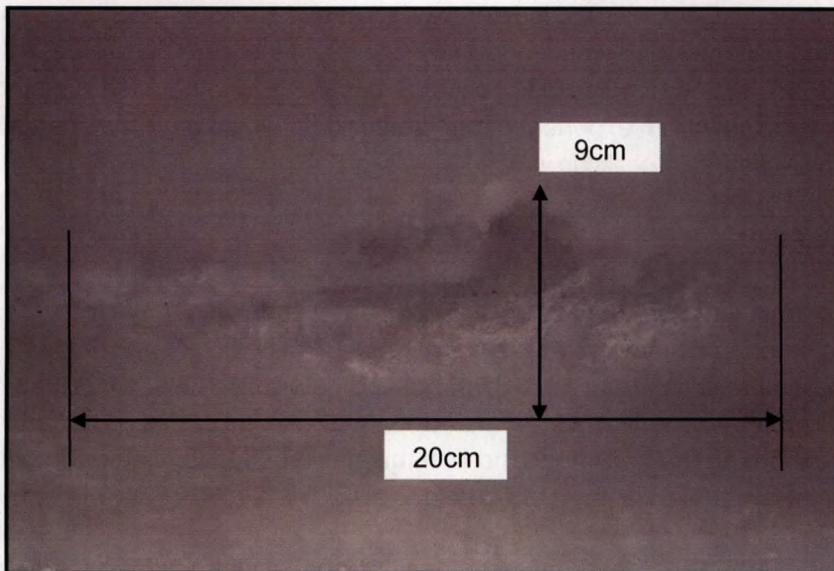

Figure 19: Close up of Figure 18 – Ice wall damage on the inside of the exit of Turn 10

The witness mark in Figure 18 represents evidence of a significant high energy impact against the LHS ice-wall at Igls on the exit of Turn 10. Due to the time elapsed<sup>79</sup> between the IP's accident and the visit by the NSI team this impact mark could not be confirmed as being directly attributed to the accident on 29 Jan 18. Whilst the position of the witness mark on the ice wall is consistent with the IP's trajectory established from CCTV footage, and is corroborated by Coach 2 as being in the area of the IP's collision, it is not possible to be certain that this is the damage caused by the IP at Impact Point 6. It is however highly probable<sup>80</sup> that the IP had a high energy impact with the LHS of the ice wall on the exit of Turn 10 very close and consistent with the impact mark detailed at Figure 18 and Figure 19.

Based on the witness statement from Coach 2, the impact damage to the ice wall on the exit of Turn 10 (Figure 18) and the CCTV footage it is extremely likely that the IP lost momentum and fell from a height of approximately 4.5m and experienced a high energy impact and a significant deceleration event with the LHS ice wall on the exit of Turn 10 just out of CCTV Line of Sight (LoS). This is corroborated by Coach 2's account of the accident phase and further supported by the CCTV footage of the IP departing her sled as she comes back into view on the exit of Turn 10

<sup>79</sup> NSI team visited Igls Austria 26 Feb 18.

<sup>80</sup> Table 1 - Probabilistic Language - DAIB SOP514.



(Figure 7). The Track Manager stated in interview that Turn 10 and Turn 14 are the mostly likely corners for accidents to occur at the Igls Ice-Track; he further stated that he believed the loss of sled control experienced by the IP during her 2nd run was recoverable<sup>81</sup>.

It is not known if the IP suffered a head trauma as a consequence of Impact Point 6 however the available evidence suggests it is extremely likely that a significant high energy deceleration event occurred at this point which subsequently threw the IP from her luge sled. It is not possible to determine if the IP impacted her head prior to Impact Point 6 but it is highly likely that a head impact occurred at this point; CCTV footage confirms that blows to the IP's head were also sustained at Impact Points 7 and 8 (Figure 7). 1710 NAS also confirmed<sup>82</sup> that the IP's sled made contact with the IP's helmet after she departed the sled.

The RAF BLSA Bobsleigh Coach stated in interview<sup>83</sup> that she knew the accident was serious as an athlete who comes off their sled would normally slide down the track; in this case the RAF BLSA Bobsleigh Coach stated that she was concerned as the IP and her sled remained in the vicinity of Turn 11 and knew from experience that the accident would have involved a significant loss of momentum caused by a collision.

#### **The NSI concluded that:**

The IP lost sled control along the track straight out of Turn 9 and was unable to successfully execute corrective steering actions prior to entering Turn 10. The IP entered Turn 10 at a high angle and lost momentum falling from a height of approximately 4.5m and suffered a high energy deceleration event on the exit of Turn 10. The IP departed her sled at this point and impacted her head at least twice more on the track floor and with the sled; subsequently the IP continued to slide unconscious toward the entry point of Turn 11.

Post the IP's accident RAF BLSA coaches introduced additional instructions<sup>84</sup> for the remaining novices instructing them to "put their feet down should they get into difficulty on the ice"; Novice 1 and 2 stated that the novice athletes did not receive this additional safety instruction prior to the IP's accident on 29 Jan 18. Intermediate athletes 1 and 2, Novices 3, 4, 5, and 6 all stated that this instruction was verbally given by the RAF BLSA Coaches before the IP's accident but could not confirm exactly when it was delivered. Coach 1 stated that he can recall briefing the novice athletes a loss of sled control recovery technique by instructing them to put their feet down to re-establish sled control prior to the IP's accident; the IP was not able to be interviewed.

No procedures, checklists or any formalised or assured processes for the delivery of novice luge training were given to Coach 1 by the RAF BLSA. It is not possible to determine if the following instruction was given to the novice athletes by the RAF BLSA prior to the IP's accident: "*Athletes will be advised of the option of using their feet to brake and slow their speed on the first couple of runs*"<sup>85</sup>. The Luge TM confirmed via e-mail<sup>86</sup> to the RAF BLSA SM and RAF BLSA Vice-Chairman that this instruction was given to all of the novice luge athletes after the IP's accident as part of the mitigation for the resumption of the novice luge event.

<sup>81</sup> Evidence reference - DAIB/18/003/2007.

<sup>82</sup> Evidence reference - DAIB/18/003/2058.

<sup>83</sup> Evidence reference - DAIB/18/003/6006.

<sup>84</sup> Evidence reference - DAIB/18/003/2049.

<sup>85</sup> Evidence reference - DAIB/18/003/2049.

<sup>86</sup> Evidence reference - DAIB/18/003/2049.



The IP had limited knowledge of the Ice-Track at Igls and had only been given limited opportunity to practice luge steering techniques. The IP received no formalised or assured luge training and was not formally assessed for competence prior to conducting on-ice luge runs on the Ice-Track at Igls.

Due to a lack of on-ice luge experience and the absence of any assured training and competency assessment the IP did not affect the necessary corrective steering actions prior to entering Turn 10 which culminated in a high entry angle and concluded in a loss of forward momentum and high energy impact on the exit of the turn.

The loss of sled control by the IP and her inability to successfully execute corrective steering actions prior to entering Turn 10 were considered **Causal factors**.

**Safety Recommendation – The RAF BLSA RP should introduce an assured on-ice novice luge athlete competency assessment which includes an assessment of an athlete’s knowledge and ability to react to a loss of sled control event.**

#### 4.6 RAF BLSA Assurance

The RAF BLSA luge discipline has been deemed a High-Risk Sport by Sport England; AP 3415 mandates that assurance activity for this category of sport requires 1st and 2nd Party internal audits with the 2nd Party assurance element conducted by the RAF DRS every 18 months<sup>87</sup>. Third Party external audits of the RAF DRS are also mandated with the AP3415 on a risk based approach conducted either by the appropriate NGB, other Service FLCs or by the RAF Safety Centre.

RAF BLSA 1st Party Assurance should be complied with by annual completion of the RAF DRS Assurance Self-Assessment Questionnaire. An RAF DRS Assurance Self-Assessment Questionnaire<sup>88</sup> was completed by the RAF BLSA SM in Nov 17 prior to the BLSA Novice Ice Championships 18; this questionnaire requires minimal input and provides only limited risk management assurance and does not cover the assurance of the supervision, training and competence of RAF BLSA novice athletes.

The RAF DRS are the controlling authority and responsible for policy, governance and assurance of RAF sport; 2nd Party Assurance should be conducted on the RAF BLSA luge discipline by the RAF DRS every 18 months<sup>89</sup>. The RAF BLSA luge discipline has not had a 2nd Party Assurance audit by the RAF DRS<sup>90</sup>; the RAF DRS plan to conduct a 2nd Party audit on the RAF BLSA in Nov 18<sup>91</sup>.

A 2nd Party audit<sup>92</sup> of the RAF BLSA Natural Luge discipline<sup>93</sup> was conducted by the RAF DRS in March 17. A previous RAF BLSA Natural Luge discipline 2nd Party audit<sup>94</sup> was conducted by the

<sup>87</sup> Evidence reference - DAIB/18/003/2029.

<sup>88</sup> Evidence reference - DAIB/18/003/2013.

<sup>89</sup> AP 3415 details the requirement for High Risk sports to be Audited every 18 months and also details the scope of the 2<sup>nd</sup> Party Audit.

<sup>90</sup> Evidence reference - DAIB/18/003/6016.

<sup>91</sup> Evidence reference - DAIB/18/003/2023. The Audit scheduled for Nov 18 does not explicitly identify that the RAF BLSA luge discipline will be audited.

<sup>92</sup> Evidence reference - DAIB/18/003/2021.

<sup>93</sup> A sister sport to luge but is a totally separate ice discipline requiring a separate 2<sup>nd</sup> Party audit by the RAF DRS.

<sup>94</sup> Evidence reference - DAIB/18/003/2022.



RAF Safety Centre in Jan 15 and is the only other 2nd Party audit conducted on the RAF BLSA. In interview the RAF DRS SO3 Assurance stated<sup>95</sup> that no other 2nd Party audits have been conducted to date by the RAF DRS on the RAF BLSA High-Risk ice sport disciplines of bobsleigh, luge and skeleton.

The RAF Safety Centre Natural Luge discipline audit dated Jan 15 identified a number of specific findings regarding coaching qualifications and SQEP within the RAF BLSA. There is no evidence of any 3rd Party risk based assurance activity of the RAF DRS conducted either by the RAF Safety Centre, NGB or other FLC as mandated within AP 3415.

**The NSI concluded that:**

RAF BLSA luge has been classified as a High-Risk Sport<sup>96</sup> and should be assured every 18 months<sup>97</sup> by the RAF DRS. The RAF BLSA 1st Party assurance policy mandated by the RAF DRS is not comprehensive enough to adequately assure the training and supervision of novice athletes and does not provide an effective means of assuring the management functions within the RAF BLSA Luge Team; no assured processes or procedures have been established by the RAF BLSA to provide RAF BLSA coaching staff with training directives or guidance on the delivery of novice training and the assessment of novice athlete competency.

A lack of 2nd Party Assurance for the RAF BLSA luge discipline by the RAF DRS and no 3rd Party risk based assurance of the RAF DRS by either the RAF Safety Centre, NGB or other FLC were all considered to be **Contributory factors**.

**Safety Recommendation – The RAF DRS should conduct a review of the RAF BLSA 1<sup>st</sup> Party Assurance process including the 1<sup>st</sup> Party Assurance documentation contained with the AP 3415 in order to ensure it adequately assures the supervision and training of RAF BLSA novice athletes.**

**Safety Recommendation – The RAF DRS should continue their 2nd Party Assurance Audit programme for the RAF BLSA, with a particular focus on the luge discipline, and assure the Head RAF Sport that the Safety and Risk Management strategy and assurance policy adopted by the RAF BLSA for their High-Risk sports disciplines is compliant with AP 3415, JSP 660 and DSA 01.**

**Safety Recommendation – The RAF Safety Centre should establish a 3<sup>rd</sup> Party Assurance programme of the RAF DRS in order to comply with AP 3415.**

**Safety Recommendation – The DG DSA should review the current Assurance of and/or the Regulation of on-duty High Risk sporting activities within the military in order to ensure an appropriate level of Safety Assurance.**

<sup>95</sup> Evidence reference - DAIB/18/003/6016.

<sup>96</sup> AP 3415 Leaflet 15 Annex A.

<sup>97</sup> AP 3415 Leaflet 15 Annex C.



#### 4.7 RAF BLSA Luge Training

The RAF BLSA SMP mandates that discipline TMs are to arrange for SQEP coaching staff to train athletes at the track selected for an ice event.

The RAF BLSA conducted a non-mandatory street “wheeled” Luge Taster day<sup>98</sup> at RAF Halton to introduce potential athletes to the luge discipline; this event simulates some of the aspects of luge but does not replicate on-ice steering. Some instruction on steering techniques is given but no formal process or procedures exists for this event. The IP attended a wheeled Luge Taster day at RAF Halton prior to travelling to Austria. The IP was selected by the RAF BLSA Luge TM as having the personal qualities and physical coordination to deploy to the RAF BLSA Novice Ice Championships 18. The Luge Taster day is not a mandated novice luge training event; several novice athletes deployed to Igls without attending a wheeled Luge Taster day.

The nominated Luge TM did not deploy for the RAF BLSA Novice Ice Championships 18, the responsibilities for the safety management and supervision of the novice luge team were initially delegated<sup>99</sup> by the RAF BLSA RP within the AO to the RAF BLSA SM and then subsequently delegated to Coach 1 who had been deemed SQEP by the RP. This is in line with RAF BLSA policy however no formal face-to-face handover took place between the Luge TM and Coach 1 although a number of e-mails, phone calls and social media messages were exchanged.

Coach 1 stated<sup>100</sup> that he was aware of his responsibilities for novice safety and that the AO for Novice Ice Championships 18 was the policy document that provided TM guidance; Coaches 1, 2 and 3 stated<sup>101</sup> they were not aware of RAF BLSA policy contained within the RAF BLSA SMP. Coaches 1, 2 and 3 further stated that they delivered novice training based on their own experiences and knowledge handed down from more experienced coaches within the RAF BLSA and GB Luge Teams; no procedures or formal guidance was given to the coaches by the RAF BLSA on how to train the novice luge athletes or how to assess them as competent prior to conducting on-ice activities at Igls.

The IP attended an on-ice starter gate event<sup>102</sup> at Konigssee in Germany<sup>103</sup> prior to arriving at Igls and was deemed competent by the RAF BLSA coaching staff to travel and compete on the Ice Track at Igls Austria. This initial ice event in Germany provided the novice athletes with some on-ice experience. Coaches 1, 2 and 3 collectively determined that all of the luge novices were competent to move on the track at Igls after this event; this method for assessing novice competency has been normalised within the RAF BLSA and has not been formalised within RAF BLSA policy or assured by the RAF DRS. No formal process or procedures for training novice luge athletes exists and no formalised or assured method for determining the competency of novice luge athletes was evident during the investigation.

No Training Objectives (TO) or Enabling Objectives (EO) were set for any of the novice training and no formalised process or procedures were provided by the RAF BLSA for Coaches 1, 2 and 3 to follow. No formal competency assessment was conducted by the RAF BLSA Coaches and no

<sup>98</sup> RAF DRS conducted a 2<sup>nd</sup> Party Assurance Visit on the RAF BLSA Natural Luge event in Lusén Italy (Jan 17) and identified that the Role of the Street Luge event should be stipulated in the RAF BLSA SMP; there is no evidence that this Observation has been incorporated within the current RAF BLSA SMP 2018/19.

<sup>99</sup> Evidence reference - DAIB/18/003/2001.

<sup>100</sup> Evidence reference - DAIB/18/003/6002.

<sup>101</sup> Evidence references - DAIB/18/003/2008, DAIB/18/003/2009, DAIB/18/003/2010.

<sup>102</sup> 1-hour session on Saturday 27<sup>th</sup> January 2018 and a 2-hour session on Sunday 28<sup>th</sup> January 2018; the IP conducted several runs.

<sup>103</sup> Coach 1 stated that this event does not occur every year or form part of the BLSA Luge training due to funding.



formal documentation for novice training or assessment was made; evidence from novice athletes confirmed that verbal feedback was given to the novice athletes by coaches 1, 2 and 3. Coach 1 verbally informed all of the novice athletes including the IP that they had been assessed as competent to move on to the ice track at Igls.

Evidence from some of the other novice and intermediate athletes who also attended the Novice Ice Championships 18 indicates that some instruction may have been given by the RAF BLSA coaches pertaining on how to steer the sleds and additionally how to stabilise the sled by placing the soles of the feet on the ice.

Novice 1 stated<sup>104</sup> that instruction on a feet down recovery technique was given by the RAF BLSA staff after the IP's accident; she could not recall if this instruction was given prior to the accident. Novice 2 stated<sup>105</sup> that he could not recall being given any instruction by the RAF BLSA coaches on a loss of sled control recovery technique by putting feet down on the ice prior to the IP's accident; Novice 2 did confirm that instruction on a feet down recovery technique was given by the RAF BLSA staff after the IP's accident.

Novice 3 stated<sup>106</sup> that he was briefed on the techniques of how to position himself on the sled and what to do to maintain sled control including stabilising the sled using feet and keeping shoulders back. Novice 3 stated that the first runs on the starter ramp in Germany were undertaken whilst sat upright on the sled with feet planted on the ice.

Novice 4 stated<sup>107</sup> that he was briefed on how to position himself on the sled and what to do to maintain sled control including stabilising the sled using feet and keeping shoulders back by RAF BLSA staff before the IP's accident.

Novice 5 stated<sup>108</sup> that she believed that she was briefed before and after the IP's accident on how to use her feet to stabilise the sled should a loss of control event occur.

Novice 6 stated<sup>109</sup> that he believed that he was briefed before the IP's accident on how to use his legs to stabilise the sled. Novice 6 further stated this brief was delivered during the starter slope event in Germany prior to arriving in Austria.

Intermediate 1 stated<sup>110</sup> that he can recall the RAF BLSA staff briefing the athletes to put their feet down to re-establish sled control before the IP's accident.

Intermediate 2 stated<sup>111</sup> that he can recall a safety brief being delivered before the IP's accident but could not confirm if the brief contained a loss of sled control recovery technique. He did confirm that the RAF BLSA coaches briefed athletes to use their feet when on the ice after the IP's accident.

---

<sup>104</sup> Evidence reference - DAIB/18/003/6017.

<sup>105</sup> Evidence reference - DAIB/18/003/2043.

<sup>106</sup> Evidence reference - DAIB/18/003/2044.

<sup>107</sup> Evidence reference - DAIB/18/003/2046.

<sup>108</sup> Evidence reference - DAIB/18/003/2047.

<sup>109</sup> Evidence reference - DAIB/18/003/2055.

<sup>110</sup> Evidence reference - DAIB/18/003/2045.

<sup>111</sup> Evidence reference - DAIB/18/003/2048.



**The NSI concluded that:**

The RAF BLSA luge novice team conducted 2 on-ice sessions at the refrigerated starter gate facility at Konigssee in Germany, one on 27 Jan 18 and one on 28 Jan 18. A total of 3 hours was spent by the novice team at this event and each athlete conducted several runs down the short 30m section of track; this was the first on-ice experience for the IP. Steering and sled mounting techniques were demonstrated by Coaches 1, 2 and 3 and verbal feedback was given to the athletes on their luge abilities.

The IP had limited experience and knowledge of the Ice-Track at Igls however the IP did complete her initial ice-run on the same section of track prior to her accident without incident. Additional loss of sled control techniques were briefed to the remaining novices after the IP's accident<sup>112</sup> by Coach 1. Novice 1 and 2 stated in interview that this safety information was not briefed by the RAF BLSA Coaches prior to the IP's accident; this evidence is contrary to the statements given by Coach 1, 2 and 3. Intermediate 1 and Novice 3, 4 and 5 all stated that all novices were briefed to put their feet down if they got into difficulty prior to conducting on-ice activity at Igls, some of these witnesses could not recall who briefed this safety advice or when it was actually briefed. Novice 6 stated safety information was provided by the RAF BLSA coaches whilst in Germany prior to arriving in Austria. There is evidence to suggest that it is likely that the RAF BLSA coaching staff briefed the novice athletes during this event on how to utilise their feet to stabilise the sled however it cannot be positively determined if the IP received this safety brief.

Coach 1 had deemed all of the novice luge athletes as competent to move on to the Ice-Track at Igls without conducting any type of formal assessment of competence.

The RAF BLSA does not detail any process for the training of novice luge athletes and did not provide Coach 1 with any process or procedure to follow for the delivery of novice luge training. There is no evidence that confirms a formal or assured RAF BLSA process for the training of SPs undertaking novice luge exists. There is no evidence that confirms a formalised method for the assessment of novice athlete competency exists.

The absence of any formalised or assured RAF BLSA novice luge training processes or procedures and a lack of a formalised or assured novice luge on-ice competency assessment were considered to be **Contributory factors**.

**Safety Recommendation – The RAF BLSA RP should update RAF BLSA policy to ensure it incorporates all activities undertaken during the Street Luge/Novice Taster event.**

**Safety Recommendation – The RAF BLSA RP should update RAF BLSA policy to ensure it incorporates all activities conducted during the Novice Luge Starter gate event.**

<sup>112</sup> Luge TM e-mail 29 Jan 2018, at 22:04.



**Safety Recommendation – The RAF BLSA RP should review the requirement for an RAF BLSA Assurance Manager in order to deliver effective 1<sup>st</sup> Party Assurance.**

**Safety Recommendation – The RAF BLSA RP should formalize an “End to End” training process for RAF BLSA Novice athletes including the establishment of novice athlete Enabling and Training Objectives in order to ensure RAF BLSA coaching staff can comply with assured training processes and procedures.**

#### 4.8 RAF BLSA Medical Supervision

The RAF BLSA SMP states<sup>113</sup> that the RAF BLSA have trained medical First Responders within the association; Duty RAF BLSA Medics<sup>114</sup> are required to be trackside at all times during “sliding”<sup>115</sup> and are to be familiar with the specific track procedures; Coaches 1, 2 and 3 were not trained medical First Responders.

The RAF Doctor and RAF BLSA Bobsleigh Safety Official who tended to the IP after the accident were not nominated RAF BLSA Duty Medics as required by the RAF BLSA SMP and were both trackside coincidentally.

One additional Major injury<sup>116</sup> and at least 3 other Minor injuries occurred to other RAF BLSA novice luge athletes and staff during the RAF BLSA Novice Ice Championships 18<sup>117</sup>.

An informal Post Exercise note<sup>118</sup> was submitted by Coach 1 to the RAF BLSA; this document did not detail any information pertaining to the IP’s accident or to any of the other accidents and incidents that have been identified by this NSI as occurring during the RAF BLSA Novice Ice Championships 18:

- Novice 1 confirmed she sustained a suspected fracture injury to her arm and attended the local hospital in Austria.
- Novice 2 confirmed injuries to Novice 6 and another athlete.
- Novice 3<sup>119</sup> confirmed injuries occurred to Novice 7 and another novice athlete.
- Novice 4 and 5 both stated<sup>120</sup> that another luge athlete broke a thumb and required hospital treatment. Novice 5 indicated that there had been another novice athlete with a shoulder injury but could not recall the detail.

<sup>113</sup> Evidence reference - DAIB/18/003/2002.

<sup>114</sup> First Responder trained to a BTEC standard or other formally trained medic or paramedic approved by the RAF BLSA Chairman.

<sup>115</sup> A collective luge term used to describe on-ice activity.

<sup>116</sup> AP 3415 Leaflet 14 Annex defines Major Injury criteria and defines a Major Injury as including hypothermia, heat-induced illness or unconsciousness.

<sup>117</sup> This evidence is based on witness testimony.

<sup>118</sup> Evidence reference - DAIB/18/003/2029.

<sup>119</sup> Evidence reference - DAIB/18/003/2044.

<sup>120</sup> Evidence references - DAIB/18/003/2047, DAIB/18/003/2046.



- Novice 6 stated<sup>121</sup> that he also suffered a head injury<sup>122</sup> during the RAF BLSA Novice Ice Championships 18 and was knocked unconscious and received a facial injury; he required hospital treatment and suffered a concussion. On return to the UK he was stood down for 4 days by his unit medical centre. There is no evidence that this accident was reported or documented by the RAF BLSA staff as mandated by the RAF BLSA AO and SMP.
- Intermediate 1 confirmed<sup>123</sup> the RAF BLSA coaches and Novice 6s injuries.
- Intermediate 2 stated<sup>124</sup> that he suffered an elbow injury that required hospital treatment and confirmed that one of the RAF BLSA coaches also sustained an ankle injury that required hospital treatment.

**The NSI concluded that:**

None of the RAF BLSA luge coaches who deployed to the Novice Ice Championships 18 were First Responder trained or held any other formal First Responder or paramedic training as required by RAF BLSA policy. On the day of the IP's accident the RAF BLSA had not nominated any First Responder cover for the novice luge event; the Igls resort Track Manager was First Aid trained.

There is no evidence that any of the additional injuries identified by this NSI were reported by the RAF BLSA Coaching staff as required by the RAF BLSA AO, BLSA SMP and AP3415; The RAF BLSA SM was not aware of these additional injuries and the RAF BLSA RP was not informed.

The RAF Doctor stated in interview<sup>125</sup> that she witnessed the arrival of the Austrian paramedics and confirmed that the IP had received appropriate First Aid and satisfactory medical treatment; the RAF Doctor further stated that she suspected that the IP had sustained a significant head trauma as a consequence of the accident.

Due to a lack of assurance and supervision, mandated medical staff were not employed during the RAF BLSA novice luge event; none of the additional major and minor injuries that occurred during the Novice Luge Championships 18 were reported either to the RAF BLSA SM or RP.

It is acknowledged that there were other medically qualified personnel in attendance by coincidence. The absence of any First Responder coverage of the novice luge event and a lack of effective accident reporting are considered by the NSI as **Other Factors**.

**Safety Recommendation – The RAF BLSA RP should define the level of medical cover and medical equipment required for all RAF BLSA events.**

<sup>121</sup> Evidence reference - DAIB/18/003/2055.

<sup>122</sup> This accident occurred 2 Feb 18.

<sup>123</sup> Evidence reference - DAIB/18/003/2045.

<sup>124</sup> Evidence reference - DAIB/18/003/2048.

<sup>125</sup> Evidence reference - DAIB/18/003/6005.



**Safety Recommendation – The RAF BLSA RP should ensure sufficient RAF BLSA coaching staff are First Responder trained, qualified and in-date prior to each RAF BLSA event.**

**Safety Recommendation – The RAF BLSA RP should conduct a review of the RAF BLSA accident reporting procedures in order to ensure that all Major and Minor injuries are correctly defined, appropriately reported and tracked.**

**Safety Recommendation – The RAF BLSA RP should ensure a formal Post Exercise Report procedure is established to enable Lessons Identified, additional emergent hazards and all injuries can be formally reported, monitored and tracked by the RAF BLSA SM; all non-compliances should also be recorded and tracked by the RAF BLSA SM.**

#### 4.9 IP's Luge Sled

The luge equipment used by the RAF BLSA Luge Team was stored at RAF Halton within an allocated storage facility. The luge sled store was seen to have sleds propped up against radiators which may degrade the fibreglass pods (Figure 10).

There was no maintenance regime or life limiting details provided to the RAF BLSA for the luge sleds by the OEM at the time of purchase although Fibreglass Ltd recommends sled replacement after 3 to 4 seasons dependant on usage; Fibreglass Ltd stated<sup>126</sup> that they would provide guidance on request. There is no evidence that the RAF BLSA were aware of this offer from Fibreglass Ltd; the Luge TM has subsequently engaged with the OEM to seek advice.

No luge sled servicing procedures or formal service frequencies have been detailed by the RAF BLSA other than mandating an annual inspection within the SMP. The Luge TM is detailed within the SMP as being responsible for ensuring the luge equipment is serviced at least annually and service records kept<sup>127</sup>. The sleds should be checked at the start of each season by Coach 3<sup>128</sup> who is responsible to the Luge TM for the maintenance of the sleds. Coach 3<sup>129</sup> stated that the sleds are preserved out of season; this is considered good practice by the manufacturer<sup>130</sup>.

The only servicing records held by the RAF BLSA for the IP's sled identify that it was serviced in 2015; Coach 3 stated<sup>131</sup> in interview that the servicing for this sled had been carried out for the two years after this but they had not been documented. The age of the IP's sled had also not been recorded on the maintenance log; Coach 3 stated<sup>132</sup> that he estimated that the IP's sled is

<sup>126</sup> Reference e-mail - 20180425-UK Military luge Build/Maintenance Information - DAIB/18/003 2042.

<sup>127</sup> RAF BLSA Safety Management Plan 2018/19.

<sup>128</sup> Coach 3 was the nominated Kit Manager for the 2018/2019 season.

<sup>129</sup> Evidence reference - DAIB/18/003/6009.

<sup>130</sup> fiberglass@fiberglass.lv – Evidence reference - DAIB/18/003/2042.

<sup>131</sup> Evidence reference - DAIB/18/003/2033.

<sup>132</sup> Evidence reference - DAIB/18/003/2033.



approximately 5 years old. The sled manufacturer recommends an estimated lifing of 3 to 4 years dependant on usage<sup>133</sup>.

The IP was allocated with RAF BLSA Luge Sled Serial Number 1 by the RAF BLSA Coaching staff prior to departing from RAF Halton on 26 Jan 18. There is no evidence of any process or procedures for the RAF BLSA coaches to use when sizing athletes to a particular sled; evidence suggests that the method used by the RAF BLSA coaches was based on normalised practices.

Additional servicing of the sleds took place during the Novice Ice Championships 18 and consisted of a "Before Use" and "After Use" inspection. The novice athletes were initially shown how to conduct these inspections and were subsequently assisted by the RAF BLSA coaching staff.

### **IP's Luge Sled Damage**

The technical inspection of the IP's sled identified evidence of wear to the Bows of the sled Runners and scratches to all surfaces. Tape had been applied to the pod section to fix the padding to the internal surface possibly to improve the aerodynamic performance of the luge. The tape also displayed evidence of wear indicating that this was an item used by a number of athletes over a period of time; it was not possible to determine when this damage had occurred.

The Left Hand (LH) runner was cracked at the forward bridge location; this cracking was consistent with the application of a tensile load to the outboard surface of the runner. Damage was also observed on the top surface of the runner, forward of the forward bridge, covering an area approximately 10 x 7 mm. At this location part of the gel coat was missing and cracks in the gel coat propagated outwards. The loss of the gel coat material is indicative of a compression load at the center of the damage location. The cracking surrounding the loss of material indicated that a bend had occurred in the structure about this location. This damage is consistent with that produced should the forward part of the runner flex inboard and slightly upwards, pivoting about the forward edge of the forward bridge.

Gel coat material had been lost on the inboard surface of the LH runner at the forward bridge approximately 10 mm wide below the attachment bolt and 20 mm wide above the attachment bolt. Material had also been lost surrounding this attachment bolt particularly in the forward upper and lower back quadrants around the bolt, producing an asymmetrical damage pattern. The damage observed on the inboard surface of the left-hand runner was consistent with the compression loading associated with the forward runner structure bending inboard and lengthwise about the attachment bolt to the forward bridge. The asymmetrical damage about the attachment bolt indicated that the bend also contained an upwards force component.

It was not possible to determine whether the bridges, steels and runners were aligned correctly on the sled or whether a permanent deformation was present on the LHS of the equipment as a consequence of the damage; there is also no evidence of permanent deformation in the visible metallic components of the sled. The damage on the inboard and outboard surfaces of the LH runner indicated that the forward part of the runner had been pushed inboard and slightly upward; there was no evidence of a fatigue failure mechanism.

---

<sup>133</sup> Reference e-mail - 20180425-UK Military Luge Build/Maintenance Information. Evidence reference - DAIB/18/003/2041.



**The NSI concluded that:**

The RAF BLSA has no formal luge sled servicing procedures; servicing frequencies for the IP's sled have not been documented as required by the RAF BLSA SMP. There is no evidence of any processes or procedures for the RAF BLSA coaches to follow when sizing athletes to a particular sled. The only servicing records held by the RAF BLSA for the IP's sled identify that it was last serviced in 2015. The IP's sled may have been outside of the recommending life criteria from the OEM however this could not be positively determined. The IP's sled appeared to operate as expected during her 1<sup>st</sup> ice-run; there is no evidence to indicate that any of the above findings contributed to the IP's accident.

The damage to the LH runner of the IP's sled occurred as the result of the forward part of the runner bending inboard and slightly upwards about the forward bridge. There was no evidence of a pre-existing failure mechanism and therefore the damage is considered to be as a result of the accident.

The absence of any luge sled servicing procedures, sled servicing frequencies and normalised practices for the sizing of athletes is not consistent with a documented equipment care and maintenance plan and could lead to old or inadequate equipment being used. The absence of any luge sled servicing procedures, sled servicing frequencies and normalised practices for the sizing of athletes are considered by the NSI as **Other Factors**.

**Safety Recommendation – The RAF BLSA RP should establish procedures to ensure the internal management of RAF BLSA Luge equipment including the servicing of sleds, sizing of athletes to sleds and equipment usage records are appropriately maintained and assured by the RAF BLSA SM. The storage of RAF BLSA Luge equipment should also be revised in line with the OEM instructions.**

#### 4.10 IP's Luge Helmet

The helmet issued to the IP was of a FIL 2010 standard<sup>134</sup> and was fitted for comfort by the RAF BLSA luge coaches in consultation with the IP which is consistent with the OEM guidance; "To achieve the performance of which it is capable, and to ensure stability on the head, a helmet should be as closely fitting as possible consistent with comfort"<sup>135</sup>. The IP's helmet consisted of a Kelvar-composite shell with an expanded polystyrene shock absorbing shell<sup>136</sup>. There are 2 classes of helmet for this standard, the IP's helmet was a Class A helmet which protects a larger area. Figure 20 details the differences; the shaded area is added to Class A helmets, which "shall be designated to give protection against mechanical risks like abrasion"<sup>137</sup>.

<sup>134</sup> Size extra small.

<sup>135</sup> Standard BS EN 1077:2007 page 5 - Evidence reference - DAIB/18/003/2025.

<sup>136</sup> UVEX e-mail query - Evidence reference - DAIB/18/003/2034.

<sup>137</sup> Evidence reference - DAIB/18/003/2025.



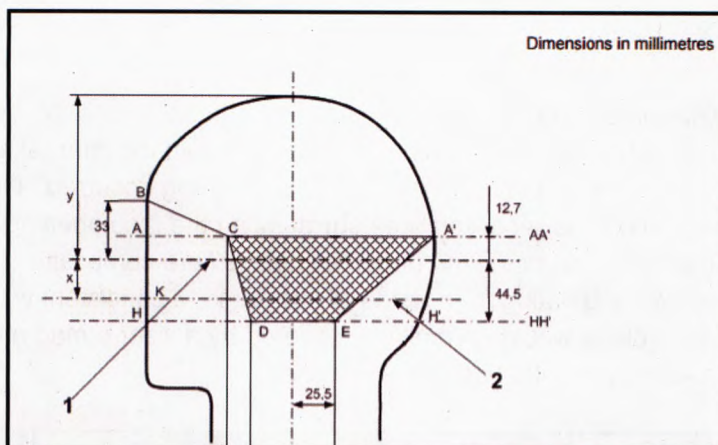

**Figure 20: Helmet Classification Areas (Standard - FIL 2010 050)**

There was no evidence of any lifing criteria or individual helmet identification recorded by the RAF BLSA; the latest OEM user manual for luge helmets details lifing as a maximum of 8 years from the date of production with an additional recommendation that helmets should be replaced 3 to 5 years from initial use<sup>138</sup>. No information was available for legacy helmets however the manufacturer responded to a request for information from the RAF BLSA Luge TM after the NSI had commenced and was provided with the same lifing detail<sup>139</sup>. There is no evidence of this guidance either being tracked or applied by the RAF BLSA at the time of the IP's accident. This has subsequently been addressed and a 100% check of the RAF BLSA luge helmets has now been carried out; all helmets that have visible damage or manufacturing dates over 4 years are to be discarded<sup>140</sup>.

Tape had been applied by the RAF BLSA to various areas of the IP's helmet with the purpose of being a sacrificial layer in order to prolong life; this is not a practice supported by the OEM<sup>141</sup>. The IP's helmet also incorporated a local modification using a 50 cent (Euro) coin taped to the front centre of the helmet (Figure 14); this modification is also not certified by the OEM<sup>142</sup>. There is no evidence to indicate that the modification of the IP's luge helmet had been recorded formally; this practice is not in line with any RAF BLSA policy, Coach 1 and 3 stated<sup>143</sup> the practise of modifying older style luge helmets with tape and coins was normal practice within the RAF BLSA.

It is advised by the OEM that in order to maximise life of the helmets that the optimum storage conditions are "cool, dry, protected from daylight, no contact with chemicals, pressure or stress"<sup>144</sup>. Daylight can be seen to protrude into the helmet and clothing store (Figure 9) which has a certain amount of mitigation against direct sunlight as some helmets are retained in bags or boxes; not all of the RAF BLSA helmets were stored this way.

<sup>138</sup> Evidence reference - DAIB/18/003/2034.

<sup>139</sup> Evidence reference - DAIB/18/003/2035.

<sup>140</sup> Evidence reference - DAIB/18/003/2032.

<sup>141</sup> Evidence reference - DAIB/18/003/2034.

<sup>142</sup> Evidence reference - DAIB/18/003/2034.

<sup>143</sup> Evidence references - DAIB/18/003/6001 and DAIB/18/003/6002.

<sup>144</sup> Evidence reference - DAIB/18/003/2035.



**IP's Luge Helmet Technical Summary<sup>145</sup>**

Numerous scratches were present on the external shell of the helmet consistent with polishing actions. The lining of the helmet was noted to have debonded from the internal surface of the external shell; it was not possible to determine when this debonding occurred. Damage was observed in two locations within the recessed area surrounding the face opening (Figure 21). Gel coat was missing in these areas exposing the underlying glass fibre composite material; cracking in the gel coat was observed originating from areas of this damage consistent with that of impact damage. This area of the helmet would normally be covered by a visor during a luge run, this impact damage was imparted whilst the visor was not fitted.



**Figure 21: IP's Helmet Damage RHS Upper**

The LHS of the helmet was observed to be cracked in the external shell material. This was within an area of the helmet specified for testing within BS EN 13484. Gel coat material had been lost at the crack exposing the underlying glass fibre material. This damage is consistent with impact damage.

Two further areas of damage were also observed on the lower RHS of the helmet (Figure 22). The smaller area of damage is consistent with a chip, impact damage, the larger area towards the front of the helmet was also noted to have gel coat missing which exposed the cracking in the underlying composite shell structure. At higher magnification, a blue product was observed embedded within the damage. This blue product was consistent in colour to that of the gel coat of the IP's luge sled pod section. It is considered that this larger area of damage at the base of the IP's helmet was produced by an impact event between the sled pod and the helmet during the accident sequence.

<sup>145</sup> Evidence reference - DAIB/18/003/2058.



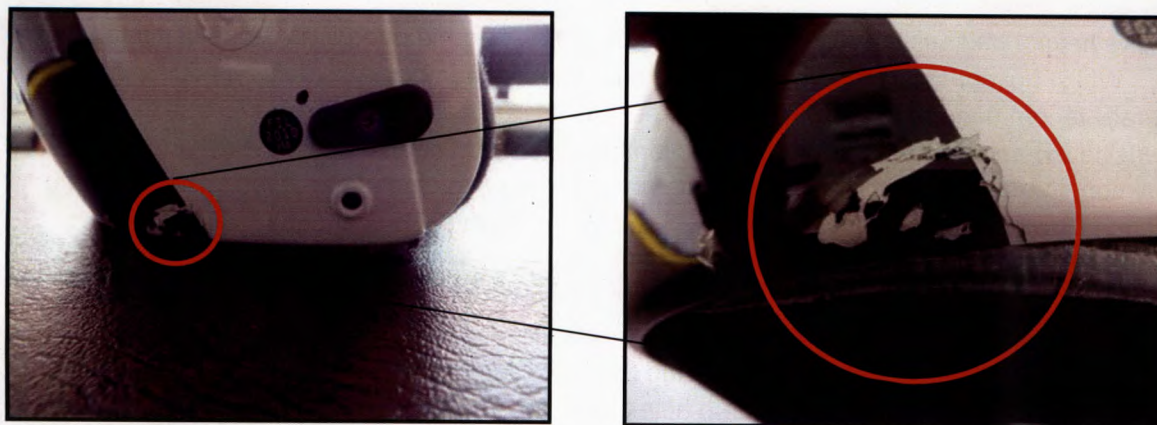

**Figure 22: IP's Helmet Damage RHS lower**

Helmets are designed to reduce harm to the head area during an accident or incident. The external shells are designed to absorb energy through a combination of fibre breakage, resin cracking and fibre resin interface debonding with the extent of the damage being influenced by the energy of the impact, the directionality and type of the impact. 1710 NAS confirmed that the IP's helmet failed in an anticipated manner.

The damage to the IP's helmet was consistent with a number of impact events during the IP's accident. Helmets are tested against a minimum shock absorbing capacity requirement, however if an accident has parameters over and above the standard test method parameters, extensive damage can occur to a helmet within an accident. It is likely that the standard test parameters were exceeded in this case resulting in the extent of the damage to the helmet.

#### **IP's Visor**

The visor<sup>146</sup> was noted to be a full face and chin covering visor designed to provide an aerodynamic shield to the athlete's face. The visor issued to the IP indicated that it was not a matched item with the IP's helmet. A visual examination of the visor also revealed that the strap displayed evidence of wear, particularly near the 'Velcro' patch, where the visor would have been fastened to the helmet. This indicated that the visor had been used on numerous occasions. Fine scratches were observed on both the inside and outside surfaces of the clear Perspex material consistent with cleaning.

#### **The NSI concluded that:**

The helmet issued to the IP was of a FIL 2010 standard; the OEM user manual supplied for this standard of helmet does not detail any lifing criteria. The latest OEM user manual for the later standard of helmet does detail lifing as a maximum of 8 years from the date of production with an additional recommendation that helmets should be replaced 3 to 5 years; there is no evidence of any lifing criteria or individual helmet identification being recorded by the RAF BLSA. There is also no evidence to indicate that the modification of the IP's luge helmet had been authorised or formally recorded by the RAF BLSA.

<sup>146</sup> Evidence reference - DAIB/18/003/003



The IP's helmet had sustained impact damage and absorbed the energy as it was designed to do<sup>147</sup>. Whilst not considered by 1710 NAS as a contributing factor to this accident, it is not generally recommended to apply tape to helmets as its application can mask damage to the underlying external shell. If the only inspection for continued use of a helmet is a visual inspection, there is a possibility that damaged helmets may continue to be used. There is no evidence<sup>148</sup> to indicate that the coin or tape used to modify the IP's helmet had impaired its effectiveness or performance.

The lack of lifing details for the IP's helmet and normalised practices of its modification do not represent best practice and are not supported by the OEM. The 1710 NAS Technical Report concluded that it is likely that the standard helmet test parameters were exceeded during the accident phase resulting in the extent of damage to the IP's helmet.

The lack of lifing details for the IP's helmet and normalised practices of the modification of the IP's helmet are considered by the NSI as **Other Factors**.

**Safety Recommendation – The RAF BLSA RP should introduce a lifing policy for luge helmets and additionally introduce an assured method of identification for all issued PPE used by RAF BLSA athletes.**

**Safety Recommendation – The RAF BLSA RP should introduce an assurance process for the tracking of RAF BLSA luge equipment maintenance, modification, servicing and lifing.**

### IP's Body Armour

No specific body armour exists for the luge discipline as the sport requires an athlete to be as streamlined as possible. The IP was issued with body armour by the RAF BLSA as a training mitigator. This body armour was of an improvised type designed for use in various other sports such as Motorcycling or Ice-Hockey; coaches 1 and 2 stated<sup>149</sup> that novice athletes can achieve enhanced protection in the context of luge by additionally inserting pieces of military sleeping system 'roll-mat' at particular impact susceptible areas under their racing suits; Novice 1<sup>150</sup> stated that some of the luge athletes used this method. It is not known what type of body armour was issued to the IP or if any 'roll-mat' was inserted within her race suit.

### The NSI concluded that:

As armour is not mandated to be used, including the use of roll-mat, in the luge discipline the provision of improvised Body Armour by the RAF BLSA was deemed sensible by the NSI. The issuing of improvised body armour to the IP is considered by the NSI as not being a factor in the accident.

<sup>147</sup> Evidence reference - DAIB/18/003/2057.

<sup>148</sup> Evidence reference - DAIB/18/003/2057.

<sup>149</sup> Evidence references - DAIB/18/003/6001 and DAIB/18/003/6002.

<sup>150</sup> Evidence reference - DAIB/18/003/6017.



#### 4.11 RN and Army Luge

The RN Luge Team was found to be heavily reliant on the Army Luge Team for the delivery of novice luge training including on-ice medical cover and the provision of Ice-Track Safety Officials; the RN Luge Team also has to utilise Army novice luge equipment as it has limited resource.

There is no evidence that the RN Luge Team has established any internal management processes or procedures for delivering luge training but has established an RN specific luge Safety Plan<sup>151</sup>. The RN Luge Team does not conduct any internal 1st Party assurance and has not had any form of 2nd Party assurance from within the RN.

The Army Luge Team manager stated<sup>152</sup> that he routinely conducts resort specific RAs prior to commencing any on-ice activity and the AO<sup>153</sup> for the Army Novice Luge events details TM responsibilities; he additionally stated that novice athletes are instructed to put their feet down should a loss of sled control occur. This instruction is not formalised or detailed within any training process or procedure. He further stated that Army novices are not mandated to wear visors and are not issued with any form of body armour.

A coaching directive<sup>154</sup> has been issued by the Army Luge Team which details the requirement for Army luge coaches to log daily on-ice activities including the assessment and competence of novice luge athletes but does not provide coaching staff with an end to end process for novice training. The Army Luge Team does mandate that qualified medical staff should be in attendance at novice luge events and has actively reported a number of accidents during recent ice events.

The Army Luge Team has not had any form of 2nd Party assurance conducted on it by the Army and does not currently conduct any internal 1st Party assurance. The Army Luge Team Manager was not aware of any Army policy or Army publications pertaining to ice sports.

#### The NSI concluded that:

The Army Luge Team delivers novice luge training independently from the RAF BLSA but does provide the RN Luge Team with coaching staff, novice luge equipment, track Safety Officials and medical cover. The RAF, Army and RN Luge Teams have not established any processes or procedures for conducting novice luge training; the Army Luge Team relies heavily on the knowledge and expertise of GB Luge Team civilian coaching staff.

No formalised training processes or procedures have been established for either the RN, RAF or Army novice luge teams; the Army and RN do not visit the starter slope facility at Konigssee Germany as part of their novice luge training. None of the Single Service Luge Teams have had any formal 2nd Party safety or assurance activities carried out on their delivery of novice luge training.

The lack of any formal 2nd Party safety or assurance activities by the RN, RAF or Army for the training and delivery of on-duty novice luge is considered by the NSI as **Other Factors**.

<sup>151</sup> Evidence reference - DAIB/18/003/2050.

<sup>152</sup> Evidence reference - DAIB/18/003/2052.

<sup>153</sup> Evidence reference - DAIB/18/003/2038.

<sup>154</sup> Evidence reference - DAIB/18/003/2037.



Whilst beyond the remit of this NSI, the Lead Investigator did additionally conclude that Safety Management Systems (SMS) should also be established to permit the safe delivery of all other High-Risk winter sports within the military.

The establishment of additional SMS to permit the safe delivery of all other High-Risk winter sports within the military is considered by the NSI as an **Observation**.

**Safety Recommendation – The Fleet Commander should ensure that a Safety Management System (SMS) is in place to permit the safe delivery of RN novice luge training.**

**Safety Recommendation – RAF D Com Ops should direct the necessary activities to assure the safe delivery of novice luge training by the RAF BLSA.**

**Safety Recommendation – The Army Sports Control Board should conduct the necessary assurance activities for the safe delivery of novice luge training by the Army Luge Team.**

#### 4.12 Post Incident Management

The nominated Novice Ice Championships 18 OiC is mandated within the AO to contact JCCC in the event of a serious accident or incident; the nominated OiC was not in attendance during week 1 of the event. Coach 1 reported the IP's accident to JCCC and informed the IP's NOK and Luge TM on 29 Jan 18; Coach 1 additionally informed the insurance company<sup>155</sup> that had been utilised by the RAF BLSA to cover this event; the IP was included within this insurance policy<sup>156</sup>.

The nominated OiC did not deploy<sup>157</sup> for the week of the novice luge event, a 2iC was nominated however there is no evidence of the 2iC being actively involved in coordinating the response to the IP's accident.

The RAF BLSA Luge TM further reported the IP's accident to the RAF BLSA Vice Chairman and detailed some additional steps he intended to introduce to mitigate the resumption of on-ice activities<sup>158</sup>. This mitigation included providing the novice luge athletes with further training on luge techniques and steering actions which included the actions to take in the event of a loss of sled control; additionally, this mitigation included an option to "use their feet to brake and slow their speed"<sup>159</sup>. A further Ice Track walk was also conducted prior to recommencing the novice luge event on 30 Jan 18<sup>160</sup>.

The AO included an Incident Management Flow Chart<sup>161</sup> which details that all Major and Minor injuries sustained during the event should be reported to the event OiC who is required to follow

<sup>155</sup> The BLSA AO details that Insurance cover should be arranged by the nominated event OiC - Evidence reference - DAIB/18/003/2051.

<sup>156</sup> Evidence reference - DAIB/18/003/2051.

<sup>157</sup> A 2iC was nominated and was present during the novice luge ice event.

<sup>158</sup> BLSA Luge TM e-mail 29 January 2018 22:04.

<sup>159</sup> BLSA Luge TM e-mail 29 January 2018 22:04.

<sup>160</sup> BLSA Vice Chairman endorsed the BLSA Luge TM post incident actions.

<sup>161</sup> RAF BLSA AO BLSA/03/2017-18 Annex D (modified extract from AP 3415 Leaflet 12 Annex C).



the action plan at Annex C<sup>162</sup>; at least 4 other injuries were sustained by RAF BLSA athletes and staff during the novice luge event at Igls including a further Major injury.

The RAF BLSA staff arranged for TRiM trained personnel to deploy to Igls and conducted TRiM interviews with the luge athletes within the 1<sup>st</sup> week of Feb 18.

**The NSI concluded that:**

The IP's accident was reported to JCCC as detailed within the AO however there was no evidence to confirm that the accident had been formally reported by the RAF BLSA on a F7454<sup>163</sup> as required by the RAF BLSA AO and AP3415. The procedures detailed within the RAF BLSA AO and SMP amplify the policy and procedures contained within the AP 3415. Coach 1 utilised the AO to activate the Major Injury Emergency Action plan as detailed in Annex D.

Witnesses confirmed that at least 4 other injuries were sustained during the novice luge event at Igls including a further Major injury; there is no evidence of these additional injuries being reported to the event OiC, RAF BLSA Luge TM, RAF BLSA SM, RAF BLSA RP or annotated within the Post Exercise note compiled by Coach 1. The RAF Doctor liaised with JCCC, UK Military Aeromed and the local hospital after the IP's accident; the RAF Doctor was not an RAF BLSA member of staff and was attending the event as a novice RAF BLSA Bobsleigh athlete.

It is acknowledged that a 2iC was nominated within the AO in lieu of an OiC for this event; this NSI identified a lack of accident reporting by the RAF BLSA Staff and a lack of post-accident coordination by the 2iC which culminated in an RAF BLSA novice athlete undertaking key OiC responsibilities specifically when liaising with the local authorities, local hospital and coordinating the recovery of the IP back to the UK.

The absence of the designated event OiC and the utilisation of non-staff to undertake OiC responsibilities are considered by the NSI as **Observations**.

**4.13 Human Factors**

The training delivered by the RAF BLSA highlighted a number of positives that encouraged effective learning; it is possible however that inadequate time had been available to fully rehearse skills, test all failure conditions and adequately fine tune expertise in controlling the luge sled.

Interview evidence appears to suggest the increase in track complexity between the on-ice sessions at Königssee in Germany and Innsbruck Ice Track at Igls Austria was significant. This may have contributed to the IP not having gained adequate experience levels to successfully execute corrective steering actions prior to entering the turns present on the Igls track.

Overall, it would appear that a combination of the complexity of the track, lack of time spent training and the lack of personal competence may all have contributed to the IP failing to successfully execute corrective steering actions during her second run of the Igls track<sup>164</sup>.

<sup>162</sup> This is a typo error in the AO BLSA/03/2017 and should refer to Annex D; Annex D is correctly referred to later in para 14 of the AO.

<sup>163</sup> Accident Report Form F7454.

<sup>164</sup> DAIB/18/003/2059.



**The NSI concluded that:**

The IP had very limited on-ice luge experience and had only conducted 1 run on the Ice-Track at Igls before the accident. A lack of on-ice training exacerbated the IP's lack of on-ice competence and are considered by the NSI as **Contributory Factors**<sup>165</sup>.

---

<sup>165</sup> Safety Recommendations - DAIB18/003/011 and DAIB18/003/018 refer.



## 5 Summary of findings and recommendations

The DAIB NSI team identified the following findings, factors and recommendations from the investigation into the RAF BLSA Novice Ice Championship 18 accident on 29 Jan 18 at Igls Austria.

### 5.1 Findings

#### 5.1.1 Causal Factors

The cause of the accident was a combination of:

- Loss of sled control by the IP.
- Inability of the IP to successfully execute corrective steering actions prior to entering Turn 10 of the Igls track.

#### 5.1.2 Contributory Factors

Contributory factors include:

- The IP's lack of on-ice luge experience and knowledge of the Igls track.
- A lack of a formalised or assured novice luge on-ice competency assessment.
- The absence of any formalised or assured RAF BLSA novice luge training processes or procedures.
- A lack of formal training for RAF BLSA Coaching staff.
- Limited knowledge of RAF BLSA safety and assurance policy by the nominated RAF BLSA Luge Coaches and Safety Officials.
- RAF DRS 1st Party audit document insufficient to adequately assure novice training, supervision and event risk management.
- A lack of 2nd Party Assurance for the RAF BLSA Luge Discipline by the RAF DRS.
- No 3rd Party risk based assurance of the RAF DRS by either the RAF Safety Centre, NGB or other FLC.

#### 5.1.3 Other Factors

- The RAF BLSA Luge TM did not deploy to the RAF BLSA Novice Luge Ice Championships 18 and delegated his responsibilities to Coach 1; no formal handover took place.



- The RAF BLSA did not deploy First Responder trained personnel for the RAF BLSA novice luge event at Igls Austria.
- The nominated OiC for the RAF BLSA Novice Ice Championships 18 did not deploy until the 2nd week of the event.
- The RAF BLSA SM did not deploy until the 2nd week of the RAF BLSA Novice Ice Championships 18.
- No specific to discipline RA for luge was carried out on arrival at the Igls resort.
- Civilian GB luge coaches were not available for the RAF BLSA Novice Ice Championships 18 due to their attendance at the Winter Olympics 18.
- No lifing policy for luge Helmets had been established by the RAF BLSA.
- The management and assurance of RAF BLSA luge equipment maintenance and servicing documentation was non-compliant with RAF BLSA policy.
- Storage of RAF BLSA luge equipment at RAF Halton does not meet OEM guidelines.
- RAF BLSA luge helmets had been modified without endorsement by the helmet OEM.
- At least 4 additional injuries<sup>166</sup> were sustained by luge athletes and staff at the RAF BLSA Novice Ice Championships 18 including an additional novice athlete head injury leading to unconsciousness which required hospital treatment; these additional injuries were not reported to the RAF BLSA SM or RP by the deployed RAF BLSA staff.
- None of the Single Service Luge Teams have had any formal 2nd Party safety or assurance activities carried out on their delivery of novice luge training.
- No formal Post Exercise Report procedure has been established in order to enable Lessons Identified, additional emergent hazards and any injuries to be formally documented.

#### 5.1.4 Observations

- The use of Body Armour for novice luge athletes is acknowledged as a sensible minor injury mitigator.
- The absence of the designated event OiC and the utilisation of non-RAF BLSA staff to undertake OiC responsibilities.
- The required establishment of additional SMS to permit the safe delivery of all other High-Risk winter sports within the military.

---

<sup>166</sup> Evidence from athlete witness statements and interviews.



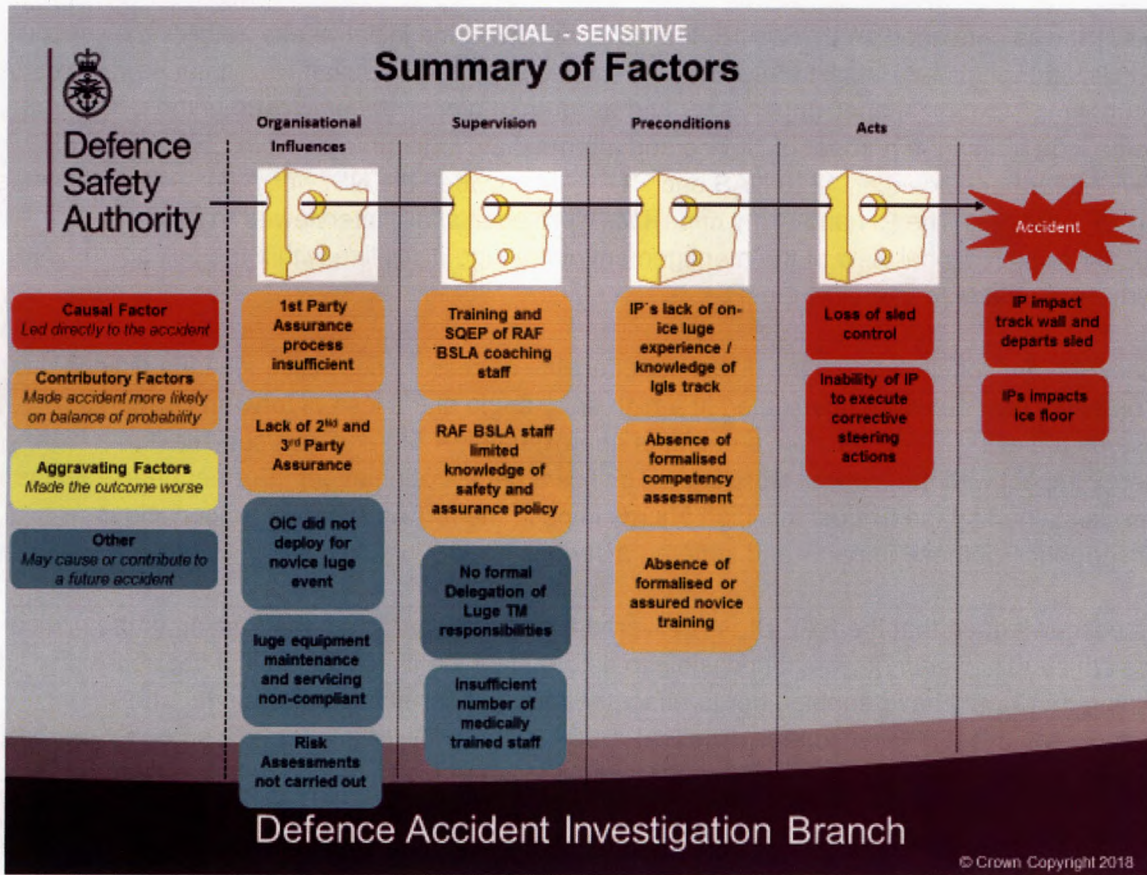

Figure 233: Summary of Factors



### 5.1.5 Conclusion

This NSI was convened on 07 Feb 18, the NSI team spent the initial weeks gathering evidence and visited the Igls Ice-Track in Austria. RAF BLSA and RAF DRS staff were interviewed to ascertain the organizational, supervisory and assurance processes employed in the delivery of novice luge training; a number of Novice and Intermediate luge athletes were contacted and provided further evidence. 1710 NAS and RAFCAM provided the NSI with independent technical and HF analysis. The RN and Army Luge TMs were additionally interviewed to ascertain a broader organizational view of the management of the luge discipline within the military; the NSI team were unable to interview the IP.

The NSI team concluded that the IP did not effect the necessary corrective steering actions prior to entering Turn 10 which culminated in a high entry angle and a loss of forward momentum towards the exit. The IP fell from a height of approximately 4.5M and was subjected to a high energy impact with the ice wall suffering a significant deceleration event. Further head impacts were sustained by the IP post this high energy impact; the IP was rendered unconscious as a consequence of these impacts and suffered a serious head injury.

It is acknowledged that the RAF BLSA delivered a staged approach to the training of the novice luge athletes; however, it was not possible to determine if the IP received all of the necessary training that would have enabled her to effect the required corrective actions after she encountered a loss of sled control. The RAF BLSA did not deliver any formalised or assured novice luge training or conduct any formalised or documented on-ice competency assessment for the IP prior to this accident. The RAF BLSA did not provide any processes or procedures for Coach 1 to follow and had not mandated a formal competency assessment to ensure each athlete had the necessary knowledge and training to recover from a loss of sled control event. The IP had very limited on-ice luge experience and had only conducted 1 run on the Ice-Track at Igls before the accident. There is evidence that a "loss of sled control" briefing may have taken place prior to the IP's accident, however there are conflicting witness accounts as to whether this briefing was delivered to all of the athletes attending the novice luge event. It can be confirmed that a "loss of sled control" brief was delivered to all of the remaining athletes post the IP's accident as part of the RAF BLSA mitigation plan for the resumption of the novice luge event.

The RAF BLSA have an established and comprehensive SMP which does provide some guidance to discipline TMs but does not provide any formal process or procedure pertaining how to deliver novice luge training. Responsibility for the supervision and training of the novice luge athletes was delegated by the Luge TM to Coach 1. There was no formal process for the Luge TM to follow to ensure Coach 1 fully understood his role; furthermore Coach 1 was not aware of all of the safety policy that was mandated within the RAF BLSA SMP. Not all of the required RAs were conducted or reviewed prior to commencing on-ice activities and safety related decisions were made by the RAF BLSA staff which had not been appropriately RA or endorsed by the RAF BLSA RP. The NGB for luge does not provide or deliver a coaching or training course for luge; the RAF BLSA have established an approach for determining the competence of their coaching staff on experience only. Each of the RAF BLSA coaches had been deemed SQEP by the RAF BLSA RP; however, none of the RAF BLSA coaches had undertaken any form of training within the military pertaining to delivering luge training to on-duty novice athletes. Coach 1, 2 and 3 all stated that they deliver training based on their own experiences and do not follow an assured process or procedure. The training delivered by the RAF BLSA did encourage some effective learning; however, it is possible that inadequate time had made been available for novice athletes to fully



rehearse all of the required skills and to adequately fine tune their individual competency in controlling the luge sled after a loss of control was encountered.

The assurance of the safe delivery of luge within the RAF is a responsibility of the RAF DRS and is mandated within the AP 3415. The RAF DRS has established an assurance plan for the RAF BLSA disciplines however no 2<sup>nd</sup> Party audit has been conducted on the RAF BLSA luge discipline; there was evidence that there is insufficient resource within the RAF DRS to adequately support the current RAF DRS assurance plan. The scope of the RAF BLSA 1<sup>st</sup> Party Assurance process was insufficient and did not provide adequate objective evidence to assure the delivery and supervision of novice luge training by the RAF BLSA. No risk-based 3<sup>rd</sup> Party Assurance had been undertaken for assuring the RAF DRS.

The servicing and maintenance records for the IP's sled had not been maintained as mandated within the RAF BLSA SMP; this was not identified by the RAF BLSA 1<sup>st</sup> Party Assurance process. No processes or procedures were provided by the RAF BLSA to their coaching staff to follow when sizing novice athletes to sleds; normalised informal practices were employed by the RAF BLSA coaches to issue and maintain all of RAF BLSA luge equipment. No helmet lifing policy had been established by the RAF BLSA and this NSI identified that a lifing criteria for luge helmets had been published by the OEM however the RAF BLSA had not been informed; this published lifing criteria has now been adopted by the RAF BLSA and shared with the RN and Army Luge Teams. Improvised modifications had been made to some of the RAF BLSA luge helmets including the one issued to the IP; this type of modification is not endorsed by the OEM.

It was confirmed that at least 4 other injuries were sustained during the RAF BLSA Novice Ice Championships 18, including a further Major injury to a novice luge athlete; there was no evidence of these additional injuries being reported to the event OiC, RAF BLSA Luge TM, RAF BLSA SM, RAF BLSA RP or annotated within the Post Exercise note. While it is acknowledged that a 2iC was nominated within the AO in lieu of the absent OiC, a lack of accident reporting by the RAF BLSA Staff and a lack of post-accident coordination by the 2iC culminated in an RAF BLSA novice athlete undertaking some OiC responsibilities.

It is recognised that sport within the military makes a significant contribution to the delivery of operational capability; High-Risk Representative sporting activities conducted within the military by novice SP are currently not regulated within the DSA Regulatory Framework. High-Risk Representative sport within the military has synergy with some military Adventurous Training (AT) activities which are currently regulated by the DSA under this framework.<sup>167</sup> No formalised training processes or procedures have been established for either the RN, RAF or Army Novice Luge Teams. None of the Single Service Luge Teams have had any formal 2<sup>nd</sup> Party safety or assurance activities carried out on their delivery of novice luge training. To ensure High-Risk Representative sport remains a core activity within the UK Armed Forces the Chain of Command should absolutely manage their respective Duty of Care responsibilities.

---

<sup>167</sup> DSA - Defence Land Safety Regulator.



## **5.2 NSI Safety Recommendations**

The following recommendations are made to reduce the likelihood of reoccurrence and enhance safety:

### **5.2.1 Organization**

#### **Safety Recommendation DAIB18/003/001**

The DG DSA should review the current Assurance of and/or the Regulation of on-duty High Risk sporting activities within the military in order to ensure an appropriate level of Safety Assurance.

#### **Safety Recommendation DAIB18/003/002**

The Fleet Commander should ensure that a Safety Management System (SMS) is in place to permit the safe delivery of RN novice luge training.

#### **Safety Recommendation DAIB18/003/003**

RAF D Com Ops should direct the necessary activities to assure the safe delivery of novice luge training by the RAF BLSA.

#### **Safety Recommendation DAIB18/003/004**

The Army Sports Control Board should conduct the necessary assurance activities for the safe delivery of novice luge training by the Army Luge Team.

#### **Safety Recommendation DAIB18/003/005**

The RAF BLSA RP should update RAF BLSA policy to ensure it incorporates all activities undertaken during the Street Luge/Novice Taster event.

#### **Safety Recommendation DAIB18/003/006**

The RAF BLSA RP should update RAF BLSA policy to ensure it incorporates all activities conducted during the Novice Luge Starter gate event.

#### **Safety Recommendation DAIB18/003/007**

The RAF BLSA RP should define the level of medical cover and medical equipment required for all RAF BLSA events.

#### **Safety Recommendation DAIB18/003/008**

The RAF BLSA RP should ensure sufficient RAF BLSA coaching staff are First Responder trained, qualified and in-date prior to each RAF BLSA event.



**Safety Recommendation DAIB18/003/009**

The RAF BLSA RP should conduct a review of the RAF BLSA accident reporting procedures in order to ensure that all Major and Minor injuries are correctly defined, appropriately reported and tracked.

**Safety Recommendation DAIB18/003/010**

The RAF BLSA RP should ensure a formal Post Exercise Report procedure is established in order to enable Lessons Identified, additional emergent hazards and all injuries can be formally reported, monitored and tracked by the RAF BLSA SM; all non-compliances should also be recorded and tracked by the RAF BLSA SM.

**5.2.2 Training and Supervision**

**Safety Recommendation DAIB18/003/011**

The RAF BLSA RP should formalize an “End to End” training process for RAF BLSA Novice athletes including the establishment of novice athlete Enabling and Training Objectives in order to ensure RAF BLSA coaching staff can comply with assured training processes and procedures.

**Safety Recommendation DAIB18/003/012**

The RAF BLSA RP should review all RAF BLSA Risk Assessments in order to ensure all hazards associated with novice luge activities have been identified and mitigated including the removal of visors.

**Safety Recommendation DAIB18/003/013**

The RAF BLSA RP should review the policy, adherence and assurance of the Specific to Discipline and Specific to Resort Risk Assessment procedures as mandated within the RAF BLSA SMP.

**Safety Recommendation DAIB18/003/014**

The RAF BLSA RP should formalise and assure the RAF BLSA Luge Team Manager delegation process.

**Safety Recommendation DAIB18/003/015**

The RAF BLSA RP should introduce a process for ensuring all RAF BLSA staff are fully conversant with RAF BLSA policy detailed within the RAF BLSA SMP.



**Safety Recommendation DAIB18/003/016**

The RAF BLSA RP should review the SQEP policy for RAF BLSA Coaches in conjunction with the RAF DRS and consider uplifting the RAF BLSA Coaching qualifications to include DSAT comparable coaching and mentoring qualifications in order to ensure all novice athletes receive appropriate on-duty training.

**Safety Recommendation DAIB18/003/017**

The RAF BLSA RP should review the use of Team GB and FIL Ice-track notes used to brief luge novices and should seek official endorsement from the luge NGB for their continued use.

**Safety Recommendation DAIB18/003/018**

The RAF BLSA RP should introduce an assured on-ice novice luge athlete competency assessment which includes an assessment of an athlete's knowledge and ability to react to a loss of sled control event.

**5.2.3 Assurance**

**Safety Recommendation DAIB18/003/019**

The RAF DRS should conduct a review of the RAF BLSA 1<sup>st</sup> Party Assurance process including the 1<sup>st</sup> Party Assurance documentation contained with the AP 3415 in order to ensure it adequately assures the supervision and training of RAF BLSA novice athletes.

**Safety Recommendation DAIB18/003/020**

The RAF DRS should continue their 2nd Party Assurance Audit programme for the RAF BLSA, with a particular focus on the luge discipline, and assure the Head RAF Sport that the Safety and Risk Management strategy and assurance policy adopted by the RAF BLSA for their High-Risk sports disciplines is compliant with AP 3415, JSP 660 and DSA 01.

**Safety Recommendation DAIB18/003/021**

The RAF Safety Centre should establish a 3<sup>rd</sup> Party Assurance programme of the RAF DRS in order to comply with AP 3415.

**Safety Recommendation DAIB18/003/022**

The RAF BLSA RP should review the requirement for an RAF BLSA Assurance Manager in order to deliver effective 1<sup>st</sup> Party Assurance.



## 5.2.4 Equipment

### **Safety Recommendation DAIB18/003/023**

The RAF BLSA RP should establish procedures to ensure the internal management of RAF BLSA Luge equipment including the servicing of sleds, sizing of athletes to sleds and equipment usage records are appropriately maintained and assured by the RAF BLSA SM. The storage of RAF BLSA Luge equipment should also be revised in line with the OEM instructions.

### **Safety Recommendation DAIB18/003/024**

The RAF BLSA RP should introduce a lifing policy for luge helmets and additionally introduce an assured method of identification for all issued PPE used by RAF BLSA athletes.

### **Safety Recommendation DAIB18/003/025**

The RAF BLSA RP should introduce an assurance process for the tracking of RAF BLSA luge equipment maintenance, modification, servicing and lifing.



## 6 References

### References

All referenced documents are held on file by the DAIB.

	Reference	Provided by
A	JSP 660 Part 1 and 2	Intranet
B	DSA 01	Intranet
C	AP 3415 Sport in the RAF Aug 17	Intranet
D	RAF BLSA Administration order BLSA/03/2017-18	RAF BLSA
E	RAF BLSA Safety Management Plan Winter season 2018/19 and associated Risk Assessments	RAF BLSA
F	DAIB Triage Report 3 Feb 18	DAIB
G	RN luge Safety Plan 2017/18	RN Luge
H	Army Luge Coaching Directive 2016/17	Army Luge
J	CCTV footage of IP's accident on 29 Jan 18	Igls Track Manager
K	RAF BLSA 1st Party Assurance self-assessment	RAF BLSA
L	RAF DRS BLSA and RAF Safety Centre natural Luge audit reports	RAF DRS
M	RAF DRS audit schedule	RAF DRS
N	RAFCAM HF Report	RAFCAM
O	1710 NAS Technical Report	1710 NAS
P	OEM user manual and manufacturing standards for UVEX Helmets	UVEX
Q	OEM build and maintenance information for IP's luge sled	Fibreglass Ltd
R	First Responder course	LIVES.
S	Insurance Policy for RAF BLSA Novice Ice Championships 18	Insignia
T	NGB coaching information	NGB for luge