



Annual Safety Review 2017



© Crown Copyright 2018

All rights reserved. Copies of this publication may be reproduced for personal use, or for use within a company or organisation, but may not otherwise be reproduced for publication.

Extracts may be published without specific permission providing that the source is duly acknowledged, the material is reproduced accurately and it is not used in a derogatory manner or in a misleading context.

Published 14 March 2018

Enquiries regarding the content of this publication should be addressed to:

Air Accidents Investigation Branch
Farnborough House
Berkshire Copse Road
Aldershot
Hampshire
GU11 2HH.

This document is also available in electronic (pdf) format at www.aaib.gov.uk

Foreword

The AAIB's purpose is to improve aviation safety by determining the circumstances and causes of air accidents and serious incidents, and promoting action to prevent reoccurrence. I am pleased to introduce the AAIB's 2017 Annual Safety Review which includes information on our activity and progress on the status of Safety Recommendations that were published in 2017.

The AAIB received 708 occurrence notifications in 2017 and deployed 38 times to conduct field investigations, 16 of which were fatal accidents in the UK resulting in 28 deaths. A further 204 investigations were conducted by correspondence. Most of the fatal accidents involved General Aviation with the dominant causal factors again being loss of control in flight and weather-related issues. In this Review, analysis has been presented of 72 fatal accidents which occurred between 2010-2015 to highlight the most common causes and draw attention to the extensive advice that is available to help pilots avoid the circumstances that all too often lead to accidents.

In 2017 the AAIB deployed to 7 accidents overseas, including to Norway, Ireland, Holland, the USA, the British Virgin Islands and the Turks and Caicos Islands, and participated in 98 other international investigations as the UK's Accredited Representative or Expert.

2017 was notable as a year in which there were no fatal accidents involving a passenger jet airliner anywhere in the world; a very welcome statistic. However, 2 passenger airliner accidents in February 2018 unfortunately provides a reality check that such catastrophes are not a thing of the past, and a forceful reminder of the human cost of such tragedies. The need to learn from accidents is as pressing as ever. But so too is the need to learn from serious incidents (which, by definition, were nearly accidents) to establish why safety margins were compromised and promote action to address any weaknesses in the system.

AAIB published 3 Special Bulletins in 2017, which each related to occurrences where the outcome was much less severe than it might have been, largely due to good fortune; two of them involved Commercial Air Transport. The AAIB is investigating these occurrences with as much rigour as if the outcome had been catastrophic to ensure the safety issues are fully understood and addressed.

In March 2017, the AAIB published its Final Report on the accident involving the Hawker Hunter aircraft which crashed on to the A27 Shoreham Bypass, while performing at the Shoreham Airshow in 2015, fatally injuring 11 road users and bystanders. A further 35 Field Investigations were concluded in 2017, and an update on the responses to all 29 Safety



Recommendations made in 2017 is provided in this Review. This Review also summarises 99 significant Safety Actions undertaken by manufacturers, operators and regulators, following close engagement with AAIB inspectors.

The AAIB must continually develop its capabilities and relationships to ensure it is ready for current and future challenges. During 2017 the AAIB completed a major review of its strategy and established priority areas for development. One example is the further strengthening of the Branch's human factors investigation capability by the recruitment of a specialist into the newly established Inspector of Air Accidents (Human Factors) discipline, and an article on this is included in this Review. Other ongoing measures include the further development of techniques for investigating accidents involving unmanned air systems, and preparing the AAIB for the advent of launches into space from the UK. In 2018 our new regulations will be laid before Parliament and we will conduct a comprehensive survey of our stakeholders to inform the further development of our working practices and our outputs. We look forward to your feedback.

In the meantime, there is a lot of information in this Annual Safety Review which I trust you will find informative and useful.

Crispin Orr

Chief Inspector of Air Accidents



Contents

Foreword	i
AAIB General Aviation Fatal Accident Review	3
Human Factors in Accident Investigation	9
CICTT Factors on Investigations by the AAIB in 2017	13
Field investigations.....	14
Correspondence investigations.....	15
Fatal investigations	16
Statistics for 2017	17
Category Definition.....	18
Notifications 2017.....	19
Notifications 2016.....	20
Notifications 2015.....	21
Safety Recommendations in 2017	23
Safety Actions from investigations reported on in 2017	32
Special Bulletin.....	32
Field Investigations	33
Correspondence Investigations.....	41
Appendix 1 - CICTT Occurrence Categories	48

Follow us on Twitter:





Boeing 737-4Q8, OE-IAQ

Belfast International (Aldergrove) Airport
4 October 2016

AAIB General Aviation Fatal Accident Review

Introduction / Overview

The AAIB has conducted a review of fatal General Aviation (GA) accident reports it published between 2010 and 2015, inclusive. The total number of accidents was 72, resulting in 105 fatalities. Of these accidents, 63 involved fixed wing aircraft and 9 rotary wing. Almost half the accidents were attributed to loss of control in flight.

This article is intended to provide pilots with a summary of the most common causes of GA fatal accidents in the UK, so that lessons may be learnt and actions taken to prevent similar accidents in the future.

Summary of events

Figure 1 shows a breakdown of the dominant causal factors in these accidents:

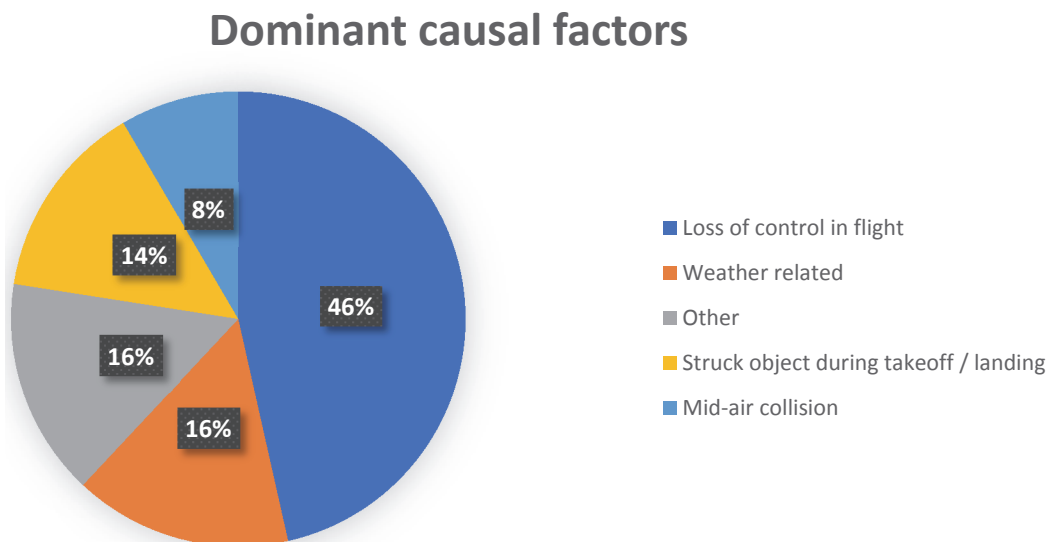

Figure 1

Analysis and commentary

Loss of Control

The predominant causal factor was loss of control in flight, which accounted for almost half of the accidents. Of these, most involved the aircraft entering an inadvertent stall and/or spin following engine failure, or during aerobatics.

The UK CAA has published a Handling Sense Leaflet to increase stall/spin awareness:

http://publicapps.caa.co.uk/docs/33/ga_srg_09webHSL02.pdf



Where the accident involved a complete or partial engine failure, the loss of control was often associated with inadequate airspeed, particularly whilst manoeuvring at low level (Figure 2).



Figure 2

[Cessna 150F, G-ATKF](#)

Hinton-in-the-Hedges Airfield, Northamptonshire
4 September 2015

Pilots are taught in the PPL syllabus how to handle a complete engine failure, but the more insidious partial engine failure is not normally covered during training. Recognising this, the Australian Transport Safety Bureau has published a safety leaflet on managing partial power loss after takeoff in single engine aircraft:

<http://www.atsb.gov.au/publications/2010/avoidable-3-ar-2010-055/>



Common features of the aerobatic accidents were a lack of pilot training and experience in aerobatics and insufficient height to recover when the planned manoeuvre was unsuccessful.

The CAA has published a Safety Sense Leaflet that contains pertinent information to consider before engaging in aerobatics:

<http://publicapps.caa.co.uk/docs/33/20130121SSL19.pdf>



Weather

A significant number of the accidents reviewed in this study were weather-related. Common themes were: collision with terrain due to flying below the minimum safe altitude (MSA) in IMC (Figure 3) and flying in IMC without the appropriate training and qualifications. Whilst new technology has undoubtedly made the tasks of flight planning and navigation easier, poor weather remains a constant threat to GA pilots and should not be underestimated.



Figure 3

[Piper PA-28-140 Cherokee, G-BHXK](#)
Near Loch Etive, Oban, Argyll and Bute
4 April 2015

The ATSB has published a safety leaflet on Visual Flight Rules pilots who enter Instrument Meteorological Conditions:

<http://www.atsb.gov.au/publications/2011/avoidable-4-ar-2011-050/>



Collision with objects during takeoff or landing

The majority of accidents in this category involved collision with power cables or trees, often at unlicensed airfields.

Operating to such airfields can be more challenging and the CAA has published a Safety Sense Leaflet to highlight appropriate considerations when operating from an unlicensed or private airstrip:

<http://publicapps.caa.co.uk/docs/33/20130121SSL12.pdf>



Mid-air collisions

Of the six accidents in this category, three occurred whilst in the circuit and the others in uncontrolled airspace.

The CAA has published a safety poster that aims to remind pilots of the standard overhead join by means of a simple pictorial representation:

http://publicapps.caa.co.uk/docs/33/ga_srgwebStandardOverheadJoinPosterJan09.pdf

The CAA has also published a Safety Sense Leaflet providing an overview of the principles of see-and-avoid and highlighting the importance of maintaining an effective visual scan:

<http://publicapps.caa.co.uk/docs/33/20130121SSL13.pdf>



Other

In this category no specific trend was identified which could help prevent future accidents.

Other resources

In addition to the links already provided, further safety information is available from the following sources:

Refresher or further training with an instructor

Flying skills are perishable. Flying instructors can provide knowledge on specific safety issues and valuable training to help pilots improve their skills.

CAA Publications

CAA safety information for recreational flying can be found at the following link:

<https://www.caa.co.uk/General-aviation/Safety-information/Safety-information/>

CAA Handling and Safety Sense Leaflets cover a wide range of topics summarising key safety points and techniques relevant to GA pilots. Leaflets are available to download here:

<http://publicapps.caa.co.uk/modalapplication.aspx?appid=11&mode=list&type=sercat&id=21>

The CAA 'Skyway Code' provides private pilots with practical guidance on operational, safety and regulatory issues related to their flying:

<https://www.caa.co.uk/General-aviation/Safety-information/The-Skyway-Code/>



General Aviation Safety Council (GASCo) Safety Evenings

These are designed to provide an opportunity for pilots to reflect on GA safety as it affects them and the people they fly with. The aim is to facilitate an exchange of views on how to improve flight safety by sharing information, thoughts and ideas.

The title of GASCo's current presentation is '*Aware Today, Alive Tomorrow*'. It addresses maintaining situational awareness and the use of threat and error management to prevent loss of control accidents, mid-air collisions and airspace infringements.

GASCo website : <http://www.gasco.org.uk/>

Safety evenings : <http://www.gasco.org.uk/safety-evenings.aspx>



Sud-Aviation SE-313B Alouette II, HA-PPC

Brighton Aerodrome, Yorkshire
17 July 2016



[Boeing 737-476\(SF\), EI-STD](#)

East Midlands Airport

29 April 2014

Human Factors in Accident Investigation

Introduction

As air accident investigators our job can often be as much about trying to understand the human contribution to an accident or incident, as it is about trying to understand the technical contribution. It can be a common misconception to think that the human involvement lies only with those most recently involved in the moments leading up to an accident, for example the pilot who happens to be at the controls at the time of the accident, the air traffic controller who issued the last clearance or the engineer or who last worked on the aircraft. However, people in operational roles often inherit decisions, policies and procedures that may have been made or implemented many years before. And they may have to carry out complex tasks involving competing priorities and variable threats in a constantly changing work environment. It is important therefore that an accident or incident investigation explores all of the aspects which have the potential to influence how an individual executes a task on any given day.



Slingsby T67M Mk II Firefly, G-BNSO
Whitwell-on-the-Hill, North Yorkshire
30 April 2016

Human factors v human error

Human error, in isolation, is not an acceptable conclusion for accident investigation. Instead, identifying the presence of human error, or human performance that was not as expected, should be the starting point for an investigation. As investigators we need to look at all the human interactions and organisational influences that may have contributed to an accident, whether those be in the immediate lead-up to an accident or further back in time. When examining these issues we have the gift of hindsight, which is not something those involved at the time of an accident possess. It is therefore vital that rather than looking back in time, scrutinising someone's actions and trying to understand them based on what we now know, we instead need to put ourselves in their shoes and understand how the situation unfolded in their eyes - what information did they have available to them at the time, what threats were they managing, how had they been trained, what condition was the equipment in? Only in this way can we attempt to work out why an individual's thoughts, actions and behaviours may have made perfect sense to them at the time. It is only when we gain proper insight into these issues that we can identify the areas that will deliver the most meaningful safety improvements.

What is 'normal'?

We must also strive to understand what 'normal' looks like. People may routinely employ work-arounds and adaptations to facilitate the smooth running of an operation, however if we only consider these in the context of the circumstances of an accident we might fail to appreciate how such actions form a normal part of the operation and routinely deliver



a safe outcome. Understanding how such tasks are normally executed by the individuals involved, and by other individuals, can provide relevant context to the investigation. And of course, it is also equally important to understand what went right as well as what went wrong, for example, what safety features worked as intended or what human interventions prevented the outcome from being even worse.

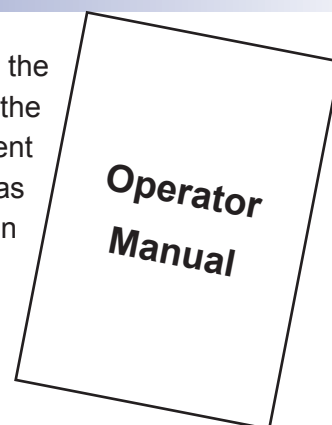

Historically

Historically the AAIB has often relied on external human factors expertise to support its investigations on a case-by-case basis. However, in recent years the AAIB has been taking steps to enhance its capability in the field of investigating human factors and human performance, including the establishment of an internal human factors working group in 2013. Included in the working group's activities were a review of how other safety investigation agencies are resourced to investigate human performance aspects, identification of suitable human factors training provision for AAIB inspectors and creation of a database of external HF expertise in specialist areas. Inspectors come to the AAIB with a wide range of aviation industry experience, and this includes some with a wealth of human factors knowledge and others with less knowledge in this area. The training identified by the working group has served to update and refresh inspectors' knowledge on the investigation of human factors and human performance issues, as well as bringing the inspectorate to a common baseline on current thinking in this field. By March 2017 all AAIB inspectors had undertaken this training and it is a mandatory requirement for all new joiners.



Human factors today

In late 2017 the AAIB embarked upon a campaign to recruit its first dedicated in-house human factors specialist. This involved the creation of a new investigation discipline within the AAIB, adding to the established disciplines of operations, engineering and flight data recording. The new Inspector of Air Accidents (Human Factors) will take up post in April 2018 and the AAIB is looking forward to integrating this new capability into our existing investigation activities and to the new opportunities that this will bring. There will still of course be a need for assistance from external specialist human factors expertise from time to time to support AAIB investigations – the field of human factors is vast and it would be impossible for any human factors practitioner to be expert in all of the many different facets of human factors. The AAIB will therefore continue to seek external expertise as appropriate under the direction of the Human Factors Inspector.

Accident Investigation Branch collaboration

In addition, over the last few years the AAIB has been working closely with colleagues from the Rail and Marine Accident Investigation Branches (RAIB and MAIB) via a tri-Branch human factors working group. While technology, procedures and operating environment can differ greatly between the transport modes, the fundamentals of human performance

in a complex or safety-critical operational environment remain the same. The cross-branch working group therefore strives to exchange experiences, learning and expertise relevant to the investigation of human factors and human performance aspects, consider ways in which human factors capability can be developed across and within the three Branches and to explore ways of developing the competence of inspectors to investigate human factors aspects. The RAIB has recruited an Investigation Support Officer who will carry out human factors research in support of investigations across the three Branches.



Conclusion

Truly getting to grips with the human performance and organisational aspects of an air accident is an integral part of the AAIB's role and the AAIB has been taking steps to enhance its capability in these areas over recent years. Recruitment of a dedicated Inspector of Air Accidents (Human Factors) is an important and defining step on this journey, and we look forward to reporting further on our progress in this field in future Annual Reports, as we continue to shape and develop this evolving capability.

Human Factors
in Accident Investigation





SZD-24-4A Foka 4, G-DBZZ

Bicester Airfield, Oxfordshire
8 August 2010

CICTT Factors on Investigations by the AAIB in 2017

Every occurrence in the UK is recorded on the European Central Repository (ECCAIRS) and is coded using the occurrence taxonomy defined by the CAST/ICAO Common Taxonomy Team (CICTT). This is a worldwide standard taxonomy to permit analysis of data in support of safety initiatives. In the UK the coding of occurrences is carried out by the CAA. It should be noted that they are recorded as multiple factors, for example turbulence (TURB) leading to loss of control in flight (LOC-I). Similarly, other (OTHER) is also used and may include maintenance manual errors or human factors, aspects that do not have specific classifications.

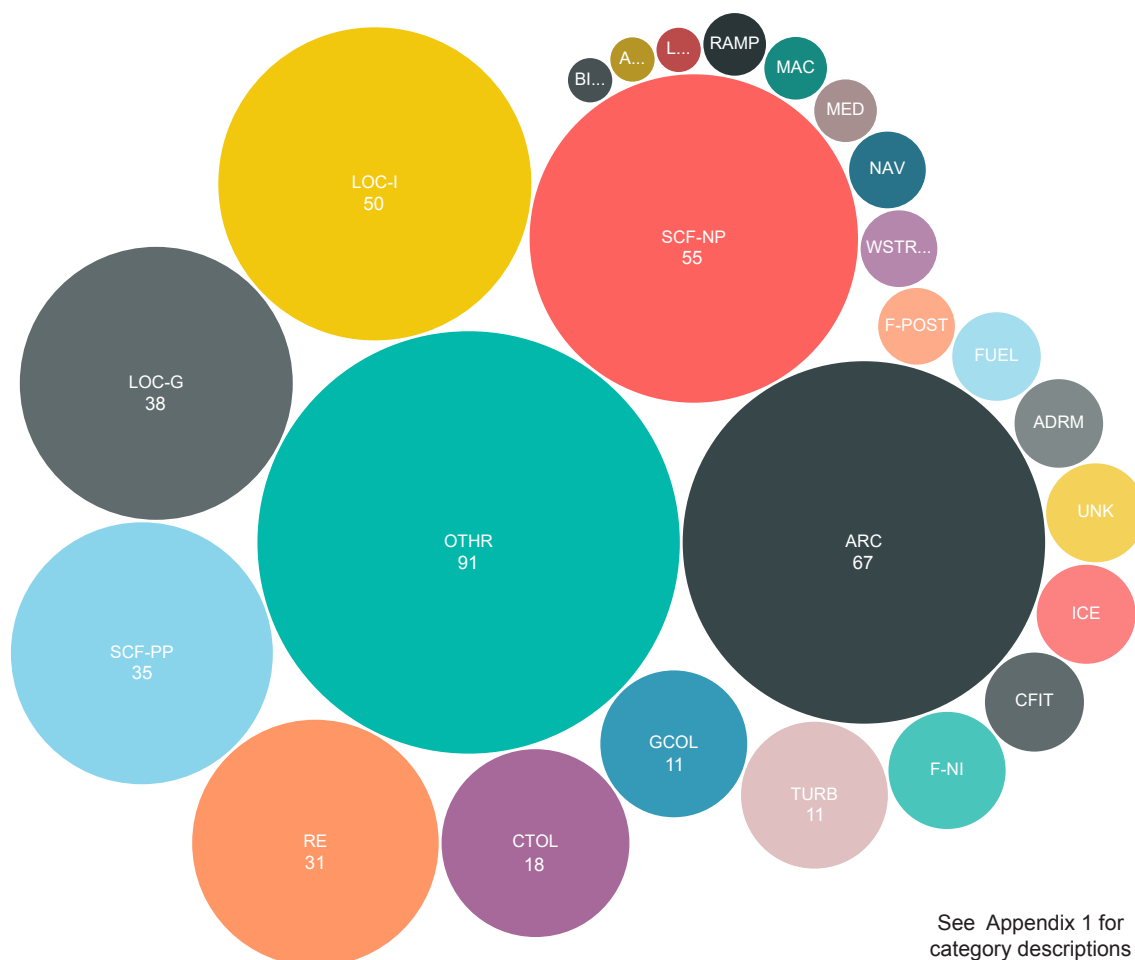

Factors for all investigations reported on by AAIB in 2017

CICTT Factors on Investigations
by the AAIB in 2017

Field investigations

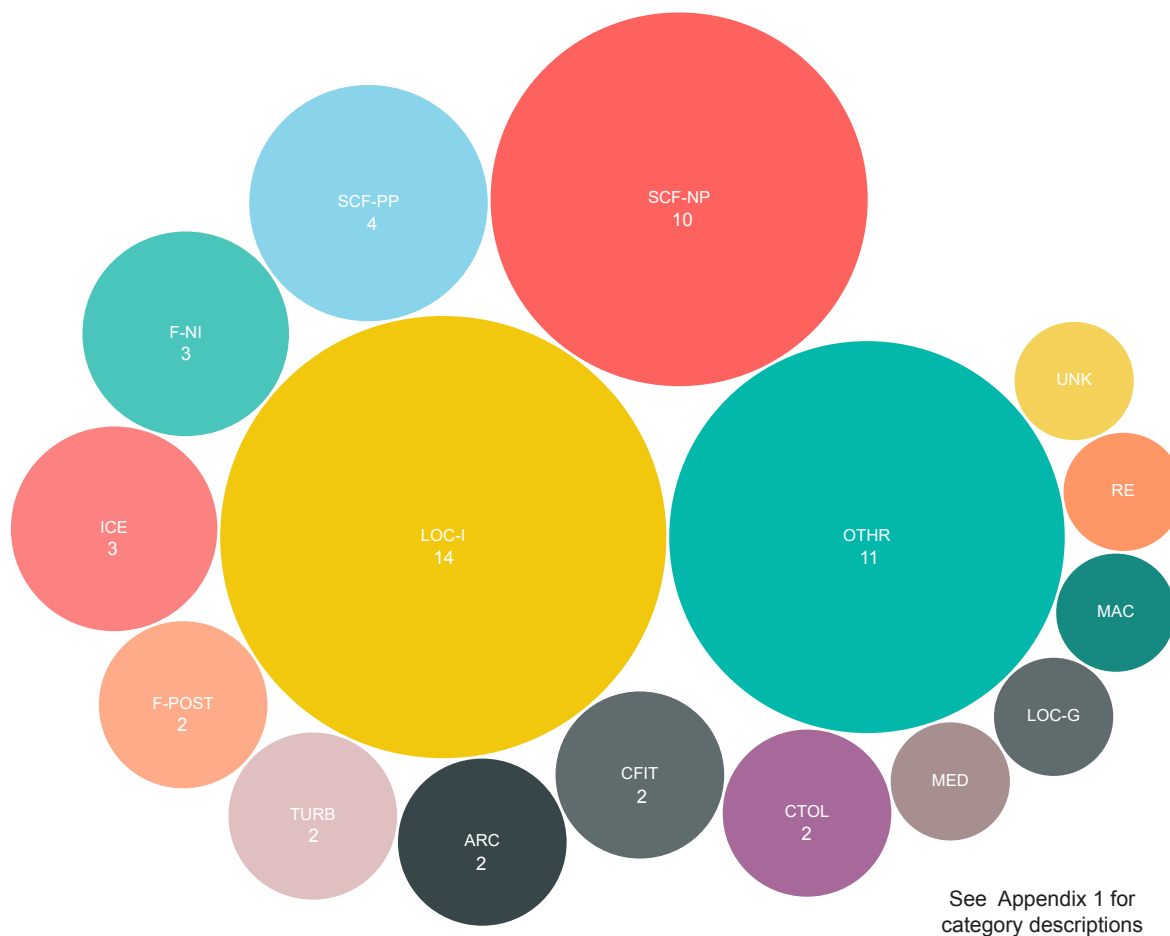

Factors for field investigations reported on by AAIB in 2017

In 2017 the AAIB reported on 38 field investigations, 16 of which were fatal accidents in the UK and 22 were non-fatal accidents or serious incidents. The analysis of the CICTT factors for each of these reveal that the overall major factor in fatal accidents reported on in 2017 was LOC-I.

The 22 non-fatal field investigations that were reported on in 2017 were mostly on serious incidents to commercial air transport (CAT) aircraft. The majority of CAT serious incidents were attributed to other followed by system/component failure or malfunction non powerplant (SCF-NP). However, in general aviation (GA) private flying, the statistics show the most prolific cause of accidents and serious incidents was again LOC-I.

Correspondence investigations

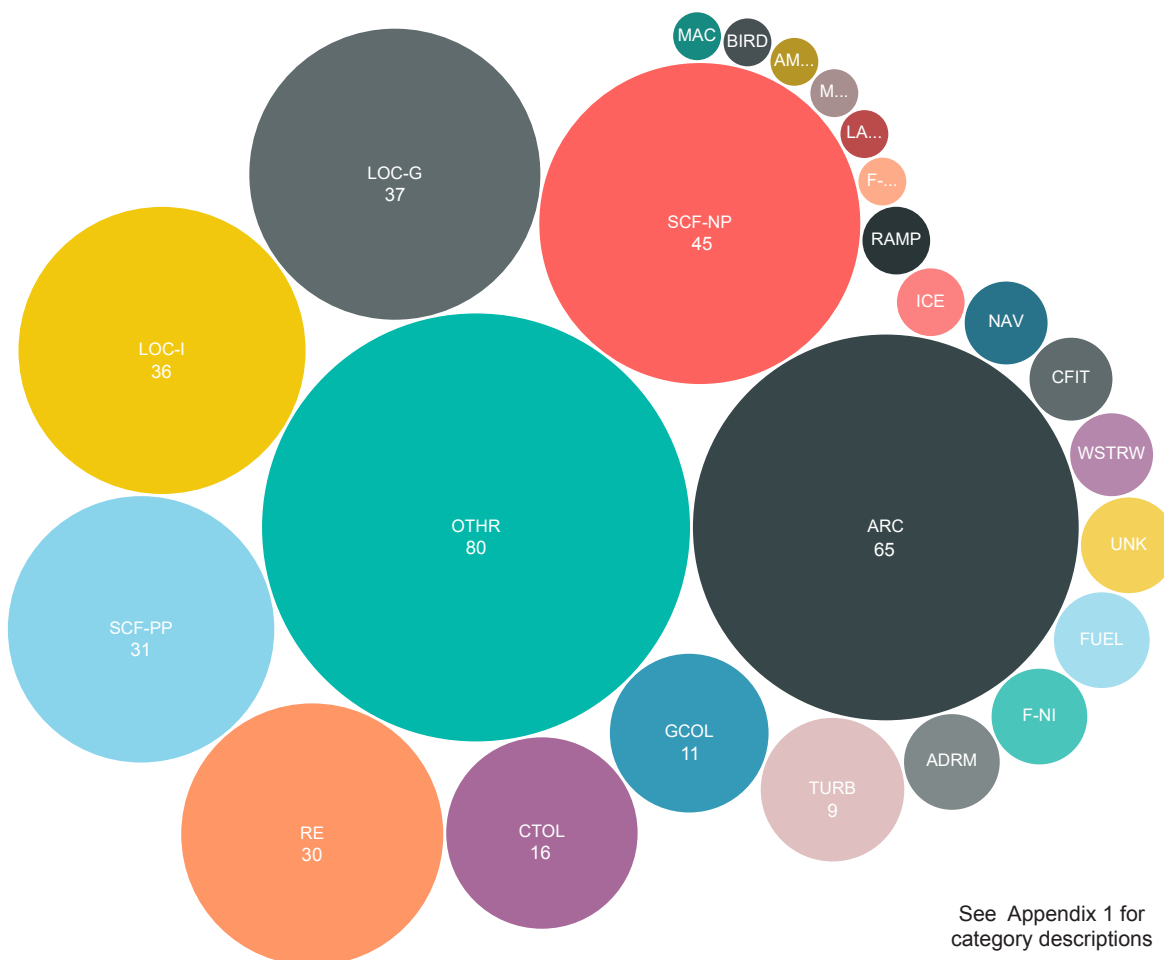

CICTT Factors on Investigations by the AAIB in 2017

Factors for correspondence investigations reported on by AAIB in 2017

Correspondence investigations are usually conducted on non-fatal accidents on GA aircraft and to some serious incidents on CAT aircraft. The factors most predominant in these occurrences were classified as other followed by abnormal contact with the ground (ARC).

Fatal investigations

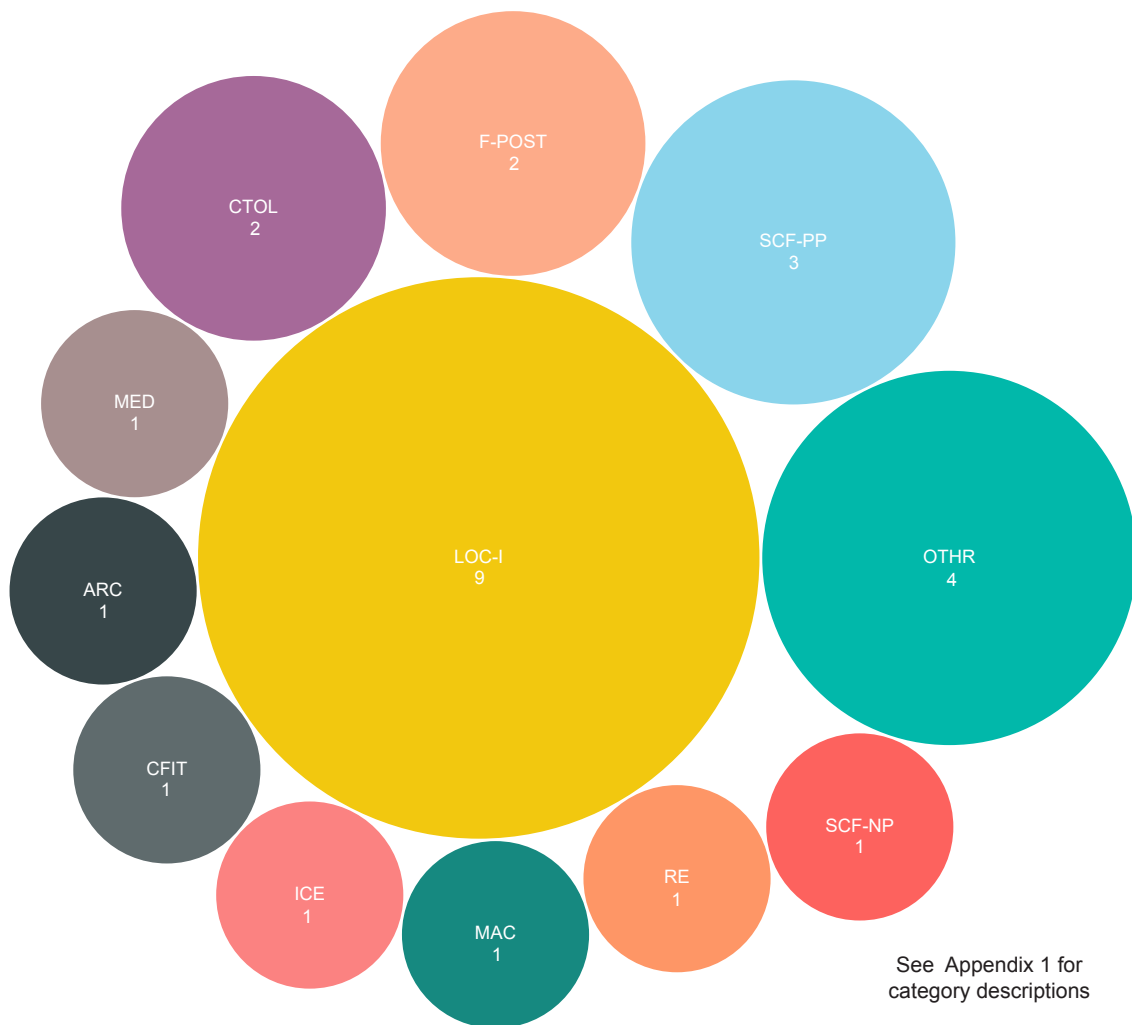

Factors for fatal investigations reported on by AAIB in 2017

The predominant cause of fatal accidents in general aviation, in common with previous years, was loss of control in flight (LOC-I). The article at the beginning of this Annual Safety Review explores the reasons behind this in more detail.

Statistics for 2017

An overview of what we were involved with during 2017 can be seen below:



Investigation Statistics

Introduction

The following pages provide the statistics for 2017, 2016 and 2015, for accidents and serious incidents involving the Air Accidents Investigation Branch.

An explanation of the categories is as follows:

Category Definition

UK Aircraft overseas	Investigations involving UK registered aircraft, or aircraft registered in one of the UK Overseas Territories or Crown Dependencies, occurring in a Foreign State where the AAIB has participated in the capacity as the Accredited Representative in accordance with ICAO Annex 13.
Foreign Aircraft overseas	Accidents and serious incident investigations to Foreign registered aircraft occurring in a Foreign State where the AAIB has participated in the capacity as the Accredited Representative or Expert in accordance with ICAO Annex 13.
UK Field Investigations	Investigations involving the deployment of a 'Field' team within the UK or to one of the UK Overseas Territories or Crown Dependencies and those investigations where a team has not deployed but Safety Recommendations are made. Also includes investigations which have been delegated to the AAIB by another State.
Military with AAIB Assistance	Where an MoD Service Inquiry is convened following an accident / serious incident to a Military aircraft and an AAIB Inspector is appointed to assist.
AARF Investigations	Investigations conducted by correspondence only using an Aircraft Accident Report Form (AARF) completed by the aircraft commander.
Overseas (no AAIB)	Notifications to the AAIB of an overseas event which has no AAIB involvement.
Referrals to Sporting Associations	Investigations referred to the relevant UK Sporting Associations.
No further AAIB action (Civil)	Occurrences notified to the AAIB involving civil registered aircraft which do not satisfy the criteria of an accident or serious incident in accordance with the Regulations.
Military (no AAIB inv)	Notifications to the AAIB concerning Military aircraft with no AAIB involvement.

Notifications 2017

	Jan	Feb	Mar	Apr	May	Jun	Jul	Aug	Sep	Oct	Nov	Dec	Total
UK Registered Overseas	5	4	3	4	5	4	6	2	5	4	2	0	44
Foreign Reg Overseas	3	3	4	9	6	7	8	4	5	2	3	7	61
UK Field Investigations	2	3	4	2	6	3	2	4	5	1	2	4	38
Military (AAIB Assistance)	0	0	0	0	0	1	0	0	0	0	0	0	1
Correspondence Investigations (AARF)	9	7	15	15	36	29	24	25	17	11	10	6	204
Overseas (no AAIB involvement)	2	1	0	1	0	0	1	1	1	1	0	1	9
Referred to the appropriate Aviation Sporting Association	4	2	1	5	9	9	4	9	3	2	2	2	52
No further AAIB action (civil)	15	19	24	22	22	29	33	27	32	34	18	23	298
Military (no AAIB involvement)	0	1	0	0	0	0	0	0	0	0	0	0	1
Total	40	40	51	58	84	82	78	72	69	55	37	43	708
UK Fatal accidents	1	0	1	1	3	2	1	1	3	0	1	2	16
Number of deaths	1	0	5	1	4	2	2	2	4	0	4	3	28

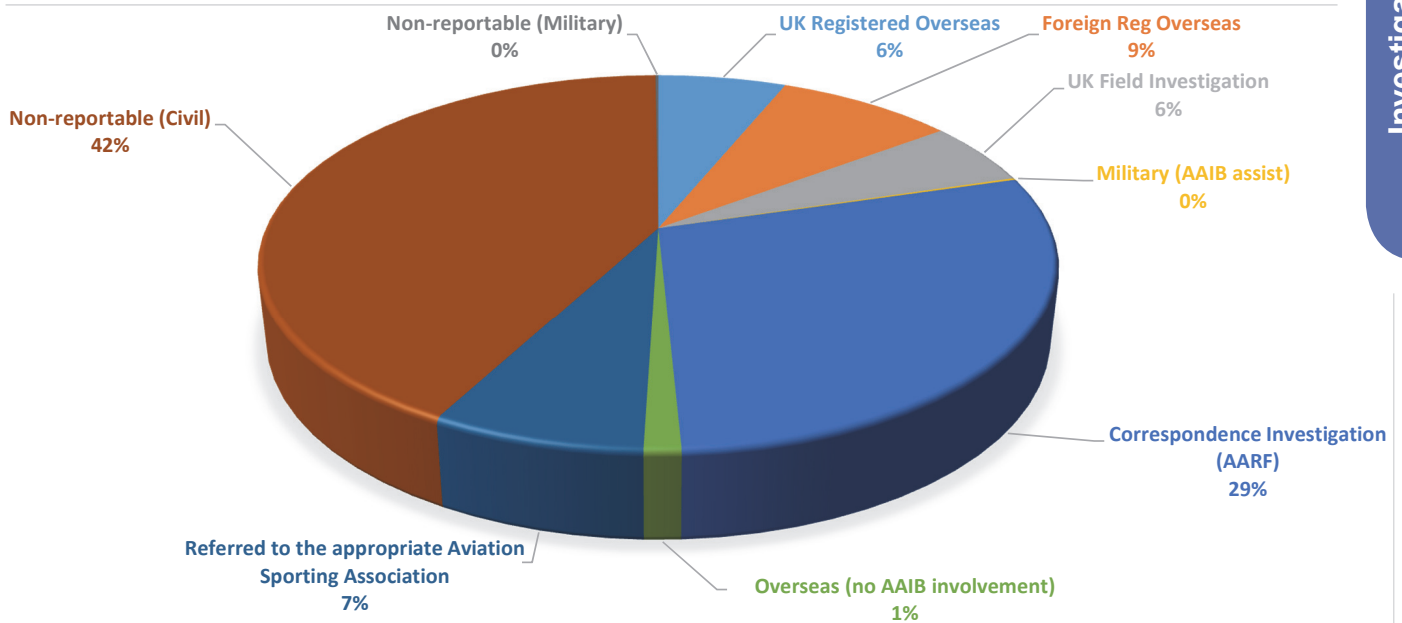

Investigation Statistics

Notifications 2016

	Jan	Feb	Mar	Apr	May	Jun	Jul	Aug	Sep	Oct	Nov	Dec	Total
UK Registered Overseas	5	3	5	6	6	4	6	4	2	4	3	2	50
Foreign Reg Overseas	1	5	4	7	4	9	3	5	18	8	6	4	74
UK Field Investigations	3	2	2	2	1	3	8	3	3	4	2	5	38
Military (AAIB Assistance)	0	0	0	0	0	0	0	1	0	0	0	0	1
Correspondence Investigations (AARF)	9	15	10	16	19	25	27	31	22	16	8	10	208
Overseas (no AAIB involvement)	1	2	1	1	0	0	0	0	0	2	0	0	7
Referred to the appropriate Aviation Sporting Association	1	2	3	4	4	3	5	9	8	4	0	1	44
No further AAIB action (civil)	18	12	19	20	22	27	29	23	21	11	15	14	231
Military (no AAIB involvement)	0	0	0	1	0	0	0	1	0	0	0	1	3
Total	38	41	44	57	56	71	78	77	74	49	34	37	656
UK Fatal accidents	0	0	1	1	1	1	4	1	1	2	0	2	14
Number of deaths	0	0	1	2	2	2	4	1	2	2	0	2	18

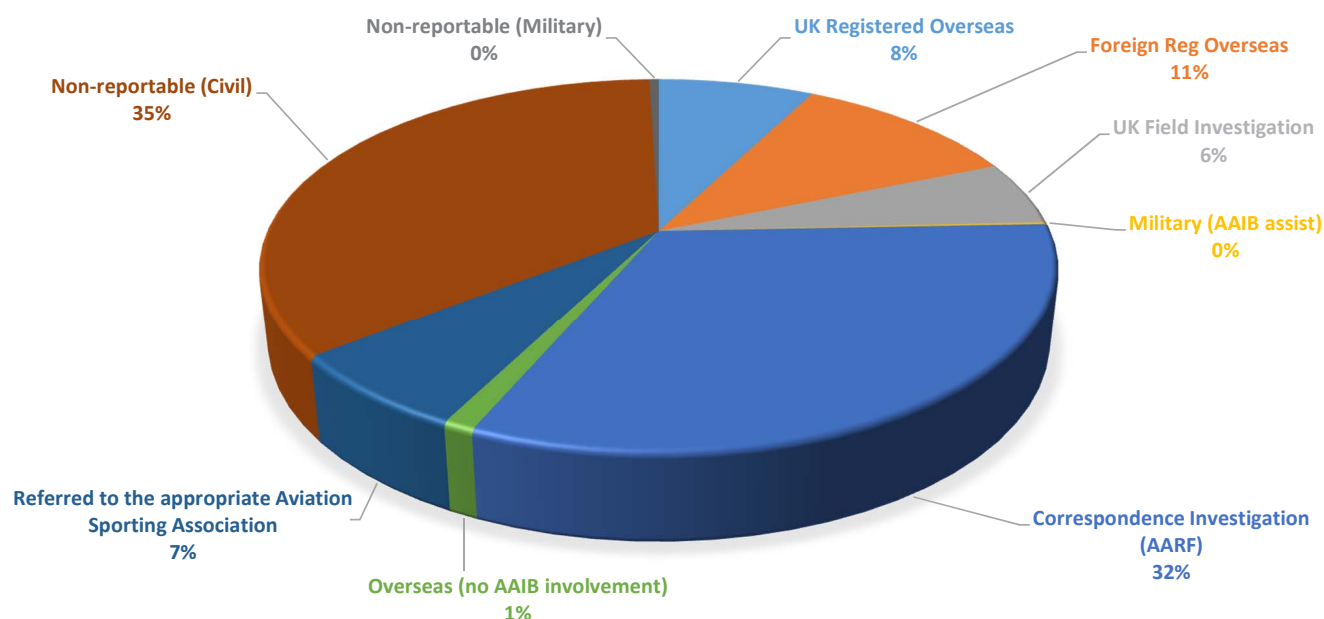

Notifications 2015

	Jan	Feb	Mar	Apr	May	Jun	Jul	Aug	Sep	Oct	Nov	Dec	Total
UK Registered Overseas	4	1	0	1	6	4	10	4	4	1	1	3	39
Foreign Reg Overseas	5	2	4	3	5	4	8	6	4	3	4	3	51
UK Field Investigations	3	1	1	5	1	5	5	4	2	3	3	1	32
Military (AAIB Assistance)	1	0	0	0	0	0	0	0	0	1	0	0	2
Correspondence Investigations (AARF)	11	7	12	24	16	29	24	20	27	12	7	5	194
Overseas (no AAIB involvement)	1	3	0	0	1	0	0	1	1	1	0	0	8
Referred to the appropriate Aviation Sporting Association	0	5	2	1	7	3	11	11	8	2	0	0	50
No further AAIB action (civil)	24	15	15	24	15	13	21	15	26	16	17	13	214
Military (no AAIB involvement)	0	0	1	0	0	2	0	0	1	2	0	0	6
Total	49	34	35	58	51	58	79	61	73	41	32	25	596
UK Fatal accidents	1	0	0	3	1	3	2	3	1	2	1	1	18
Number of deaths	2	0	0	4	2	3	6	13	1	3	4	1	39

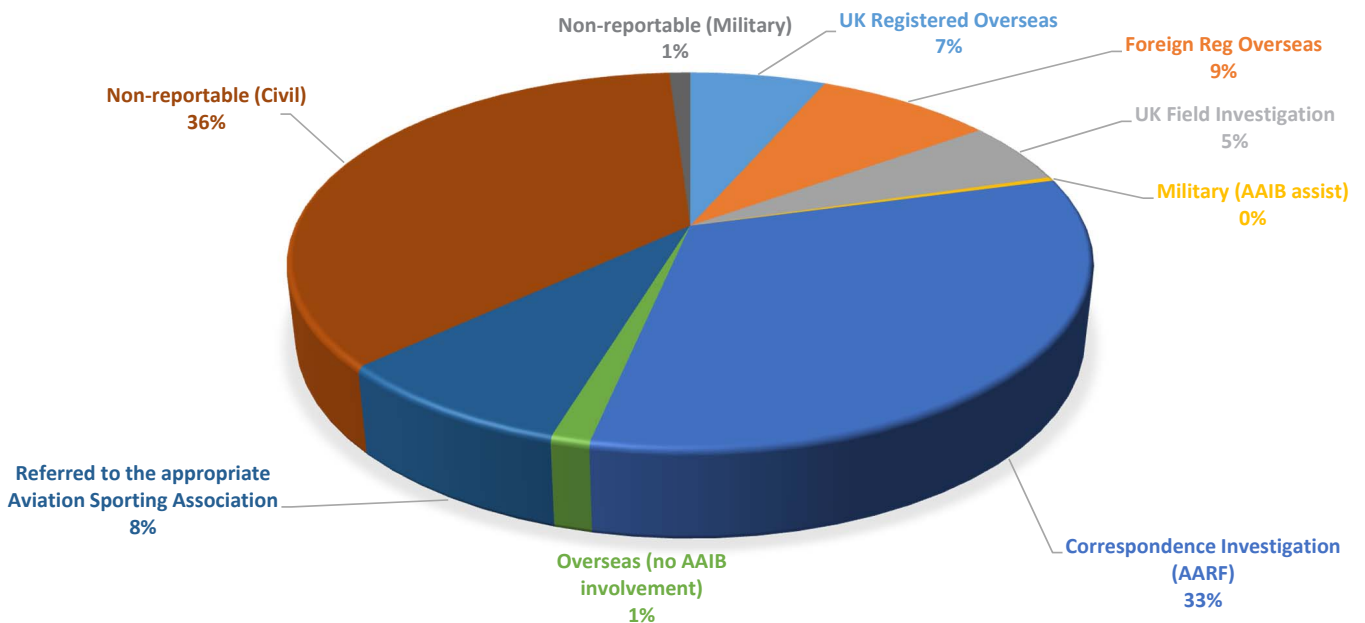

Investigation Statistics



AAIB Inspector at accident site of Boeing 737-500, VQ-BBN
Kazan International Airport, Kazan, Russia
17 November 2013

Safety Recommendations in 2017

In 2017 the AAIB issued 29 Safety Recommendations from 8 investigations.

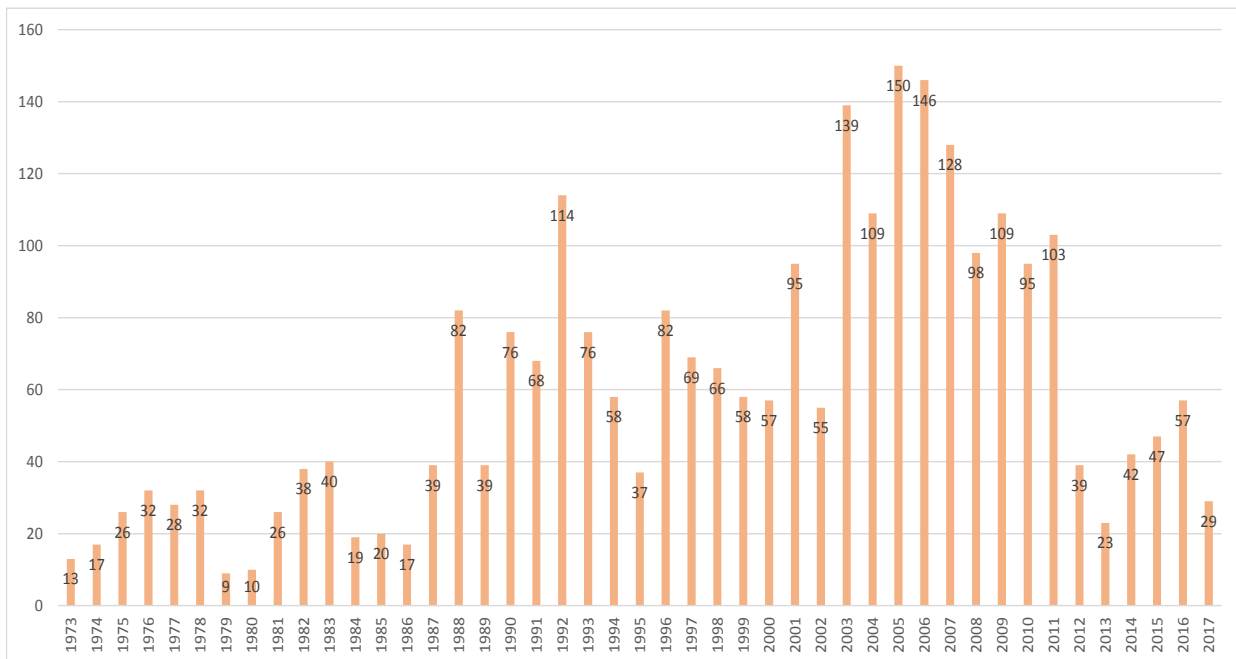

Each Safety Recommendation is classified using the SR Topic taxonomy defined by the European Network of Safety Investigation Authorities (ENCASIA) Working Group 6 (WG6) which the AAIB is a member. The majority of the Safety Recommendations were dealing with safety issues relating to aircraft operations and safety risk management.

Each addressee to a Safety Recommendation has to respond within 90 days in accordance with European Regulation EU 996/2010 Article 18 and detail what actions have been taken or are under consideration and the time taken for their completion. If no actions are being considered by the addressee they have to provide their reasoning for the decision.

On receipt the AAIB has 60 days in which to assess the response and to inform the addressee on whether it is adequate. If the reply is not adequate or partially adequate then to provide justification to the addressee.

The responsibility to monitor the progress of action taken in response to a recommendation lies with the addressee including the authorities responsible for civil aviation safety.

The AAIB will keep open Safety Recommendations where it expects to receive responses from the addressee. If no further response is expected the recommendation is closed. A closed status does not necessarily mean the actions for a Safety Recommendation are complete, nor that the Safety Issue has been addressed.

Safety Recommendation Topics

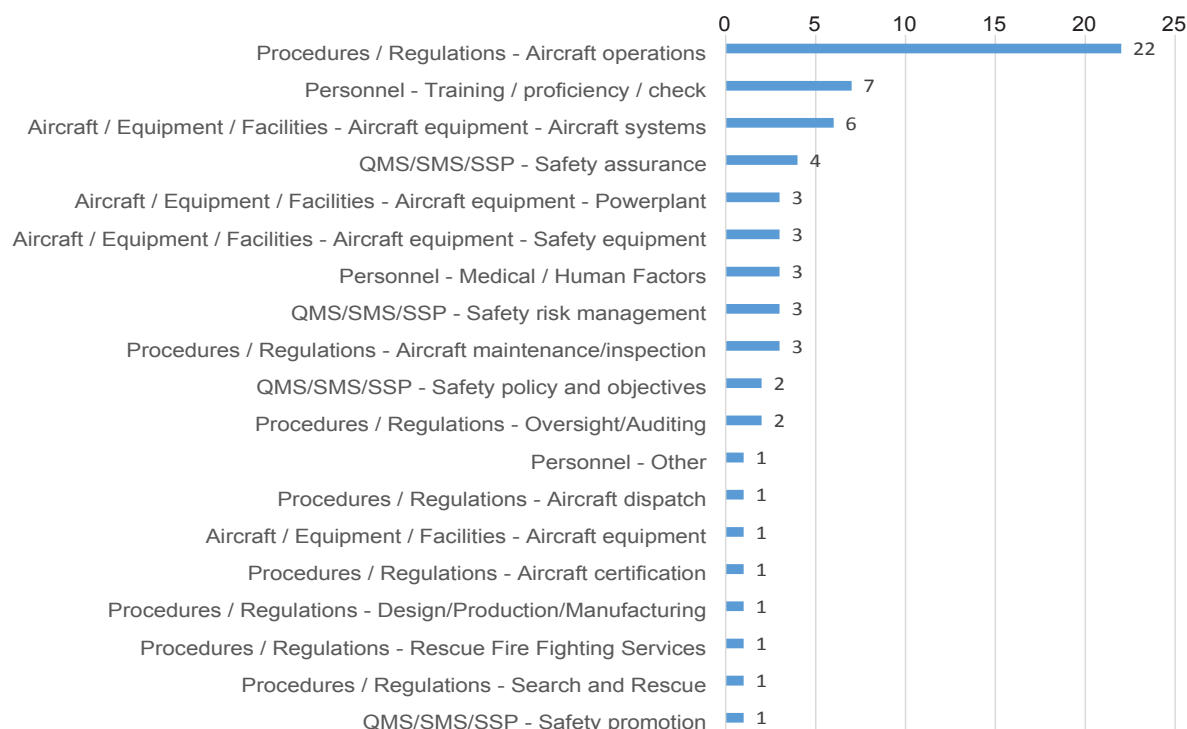

The chart above shows the recommendation topics. It should be noted that a recommendation can encompass several topics within the classification system.

A **'Not adequate'** assessment means that the response does not address the intent of the Safety Recommendation nor does it address the safety issue concerned.

A **'Partially adequate'** assessment means the response goes some way to meeting the intent of the Safety Recommendation and the action will address the safety issue to a certain extent, but further action would be required to fully address the issue identified.

An **'Adequate'** assessment means that the response fully meets the intent of the Safety Recommendation and the action is expected to address the safety issue.

Of the 29 Safety Recommendations issued in 2017, as of the end of February 2018, responses have been received for 21. In assessing the responses, 15 were adequate and closed, 5 were partially adequate and 1 was not adequate. Following the assessment, 16 Safety Recommendations from 2017 were closed, 11 remain open. The AAIB is awaiting responses from addressees for 5 of the open Safety Recommendations. Responses have recently been received for two Recommendations and are pending AAIB classification.

Each Safety Recommendation is also defined as to whether it is a Safety Recommendation of European Union Wide Relevance (SRUR) or a Safety Recommendation of Global Concern (SRGC). Of those issued in 2017, 6 were SRUR and 3 were SRGC.

The AAIB, as well as all EU Member States, is required to record on the European Central Repository Safety Recommendation Information System (SRIS) all recommendations it raises and the response that are received. Data from SRIS is available to view publicly at:

http://eccairsportal.jrc.ec.europa.eu/index.php?id=114&no_cache=1

Safety Recommendations issued in 2017

Notes: Safety Recommendation classification correct at time of publication.

Safety Recommendations can also be made through AAIB Special Bulletins and are then also reflected in the final report.

Reflects the situation with Safety Recommendations at 28 February 2018.

[Safety Recommendation 2017-001](#) made on 24 February 2017

G-BXFI Hawker Hunter T7 on 22 August 2015

It is recommended that the Civil Aviation Authority amend CAP 403 to clarify the point at which an aerobatic manoeuvre is considered to have been entered and the minimum height at which any part of it may be flown.

 Adequate - Closed

[Safety Recommendation 2017-002](#) made on 24 February 2017

G-BXFI Hawker Hunter T7 on 22 August 2015

It is recommended that the Civil Aviation Authority require pilots intending to conduct aerobatics at flying displays to be trained in performing relevant escape manoeuvres and require that their knowledge and ability to perform such manoeuvres should be assessed as part of the display authorisation process.

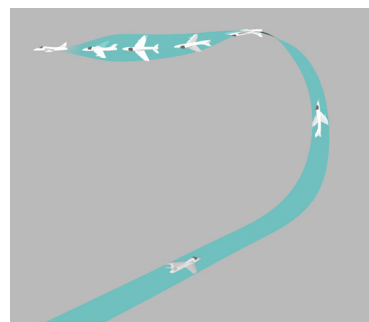

 Adequate - Closed

[Safety Recommendation 2017-003](#) made on 24 February 2017

G-BXFI Hawker Hunter T7 on 22 August 2015

It is recommended that the Civil Aviation Authority review the grouping of aircraft types in display authorisations to account for handling and performance differences it considers significant.

 Adequate - Closed

[Safety Recommendation 2017-004](#) made on 24 February 2017

G-BXFI Hawker Hunter T7 on 22 August 2015

It is recommended that the Civil Aviation Authority remind operators, whose activities are subject to the guidance published in Civil Aviation Publication 632, of the need to maintain detailed training records for pilots and check their compliance during inspections it carries out.

 Adequate - Closed

[Safety Recommendation 2017-005](#) made on 24 February 2017

G-BXFI Hawker Hunter T7 on 22 August 2015

It is recommended that the Civil Aviation Authority specify that the flight demonstration requirement of a display authorisation evaluation, other than to assess formation following, cannot be satisfied by the pilot following another aircraft during the evaluation.

 **Adequate - Closed**

[Safety Recommendation 2017-006](#) made on 24 February 2017

G-BXFI Hawker Hunter T7 on 22 August 2015

It is recommended that the Civil Aviation Authority undertake a study of error paths that lead to flying display accidents and integrate its findings into the human factors training it requires the holders of display authorisations to undertake.

 **Response Received - pending AAIB classification**

[Safety Recommendation 2017-007](#) made on 24 February 2017

G-BXFI Hawker Hunter T7 on 22 August 2015

It is recommended that the Civil Aviation Authority review the arrangements for safety regulation and oversight of intermediate and complex ex-military aircraft operated in accordance with Civil Aviation Publication 632, to ensure that they are consistent and appropriate.

 **Partially Adequate - Open**



[Safety Recommendation 2017-008](#) made on 24 February 2017

G-BXFI Hawker Hunter T7 on 22 August 2015

It is recommended that the Civil Aviation Authority consider implementing the changes outlined in Health and Safety Laboratory report MSU/2016/13 'Review of the risk assessment sections of CAP 403'.

 **Adequate - Closed**

[Safety Recommendation 2017-009](#) made on 24 February 2017

G-BXFI Hawker Hunter T7 on 22 August 2015

It is recommended that the Civil Aviation Authority require operators of aircraft used for flying displays to identify, and where practicable remove, any hazardous materials.

 **Adequate - Closed**

[Safety Recommendation 2017-010](#) made on 24 February 2017

G-BXFI Hawker Hunter T7 on 22 August 2015

It is recommended that the Civil Aviation Authority prohibit the use of phenolic asbestos drop tanks on civil registered aircraft.

 **Partially Adequate - Open**

[Safety Recommendation 2017-011](#) made on 24 February 2017

G-BXFI Hawker Hunter T7 on 22 August 2015

It is recommended that the Department for Transport commission, and report the findings of, an independent review of the governance of flying display activity in the United Kingdom, to determine the form of governance that will achieve the level of safety it requires.

 **Partially Adequate - Open**

[Safety Recommendation 2017-012](#) made on 2 June 2017

G-KAXT Westland Wasp HAS1 on 23 September 2016

It is recommended that, for ex-military aircraft on the UK civil register, the Civil Aviation Authority requires maintenance and overhaul tasks to be reviewed in the light of the expected aircraft utilisation and calendar-based time limits introduced where appropriate. Where such calendar-based time limits already exist, these should be reviewed to ensure that they are appropriate for the aircraft utilisation.

 **Adequate - Closed**

[Safety Recommendation 2017-013](#) made on 7 September 2017

G-BDZC Reims Cessna F150M on 17 October 2016

It is recommended that the Civil Aviation Authority promulgates to flying instructors the need for specific training to highlight the differences between the C150 and C152 flap switch designs. Training should also include the effect on aircraft performance and handling of Flap 40°.

 **Adequate - Closed**



Safety Recommendation 2017-014 made on 8 September 2017

G-PRPC DHC-8-402 on 14 December 2016

It is recommended that Flybe Ltd introduces defined and consistently delivered flight crew training on pre-departure inspections for the DHC-8-402 (Q400), compliant with the inspection procedure documented in its Operations Manual. This should include a practical element on the aircraft and a demonstration of correctly secured main engine access panels.

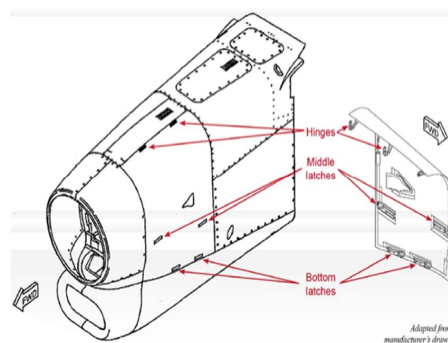

 **Adequate - Closed**

Safety Recommendation 2017-015 made on 8 September 2017

G-PRPC DHC-8-402 on 14 December 2016

It is recommended that Flybe Ltd considers introducing a means of disseminating pertinent safety information to ground operations staff in an appropriate format.

 **Adequate - Closed**

Safety Recommendation 2017-016 made on 20 September 2017

C-FWGH Boeing 737-86J on 21 July 2017

It is recommended that the Federal Aviation Administration, mandate the use of Flight Management Computer software revision U12.0, or later revision incorporating the outside air temperature crosscheck, for operators of Boeing 737 Next Generation aircraft.



 **Partially Adequate - Open**

Safety Recommendation 2017-017 made on 20 September 2017

C-FWGH Boeing 737-86J on 21 July 2017

It is recommended that The Boeing Company promulgates to all 737 operators the information contained within this Special Bulletin and reminds them of previous similar occurrences reported in the Boeing 737 Flight Crew Operations Manual Bulletin dated December 2014.

 **Response Received - pending AAIB classification**

[Safety Recommendation 2017-018](#) made on 25 September 2017

G-GSGS Glasflugel 304 ES on 10 August 2017

It is recommended that the European Aviation Safety Agency (EASA) requires that all powered sailplanes, operating under either an EASA Restricted Type Certificate, or an EASA Permit to Fly, and fitted with a Front Electric Sustainer (FES) system, are equipped with a warning system to alert the pilot to the presence of a fire or other hazardous condition in the FES battery compartment.



 **Adequate - Closed**

[Safety Recommendation 2017-019](#) made on 25 September 2017

G-GSGS Glasflugel 304 ES on 10 August 2017

It is recommended that Alisport Srl modifies the Silent 2 Electro microlight to incorporate a warning system to alert the pilot to the presence of a fire or other hazardous condition in the Front Electric Sustainer (FES) battery compartment.

 **Adequate - Closed**

[Safety Recommendation 2017-020](#) made on 25 September 2017

G-GSGS Glasflugel 304 ES on 10 August 2017

It is recommended that Albastar d.o.o. modifies the AS13.5m Front Electric Sustainer (FES) microlight to incorporate a warning system to alert the pilot to the presence of a fire or other hazardous condition in the FES battery compartment.

 **Partially Adequate - Open**

[Safety Recommendation 2017-021](#) made on 9 November 2017

G-YAKB YAK-52 on 8 July 2016

The Civil Aviation Authority should review the maintenance requirements for seat belts and harnesses, and, if necessary, revise the maintenance requirements to ensure that seat belts and harnesses remain in a condition with an acceptable residual strength.



 **Adequate - Closed**

[Safety Recommendation 2017-022](#) made on 7 December 2017

N276AY Airbus A330-323 on 26 June 2016

It is recommended that the Federal Aviation Administration mandate Service Bulletin GTCP331-49-7936 to add a system that shuts down the APU automatically if there is contamination of the lubricating oil.



Response Awaited – Open

[Safety Recommendation 2017-023](#) made on 7 December 2017

N276AY Airbus A330-323 on 26 June 2016

It is recommended that the European Aviation Safety Agency mandate Service Bulletin GTCP331-49-7936 to add a system that shuts down the APU automatically if there is contamination of the lubricating oil.



Not Adequate - Open

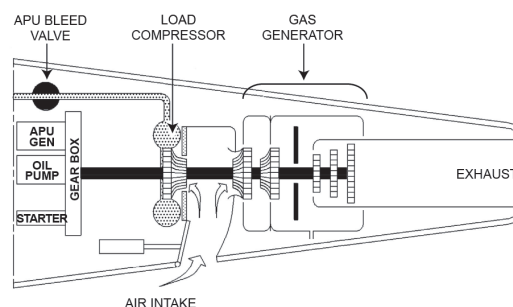

[Safety Recommendation 2017-024](#) made on 7 December 2017

N276AY Airbus A330-323 on 26 June 2016

It is recommended that the Federal Aviation Administration regulate the operation of interphone handsets, including during emergency communications, so that it is standardised irrespective of aircraft type.



Response Awaited - Open

[Safety Recommendation 2017-025](#) made on 7 December 2017

N276AY Airbus A330-323 on 26 June 2016

It is recommended that the European Aviation Safety Agency regulate the operation of interphone handsets, including during emergency communications, so that it is standardised irrespective of aircraft type.



Partially Adequate - Closed

[Safety Recommendation 2017-026](#) made on 7 December 2017

N276AY Airbus A330-323 on 26 June 2016

It is recommended that the Federal Aviation Administration reconsider the requirements for briefings given to passengers seated at exits, to ensure they offer appropriate guidance on exiting the aircraft rapidly in an emergency without implying undue responsibility for opening the exits.



Response Awaited - Open

[Safety Recommendation 2017-027](#) made on 7 December 2017

N276AY Airbus A330-323 on 26 June 2016

It is recommended that the Federal Aviation Administration require cabin crew on aircraft that are parked, and with passengers on-board who are neither boarding nor deplaning, to be evenly distributed throughout the cabin and in the vicinity of floor-level exits in order to provide the most effective assistance in the event of an emergency.



Response Awaited - Open

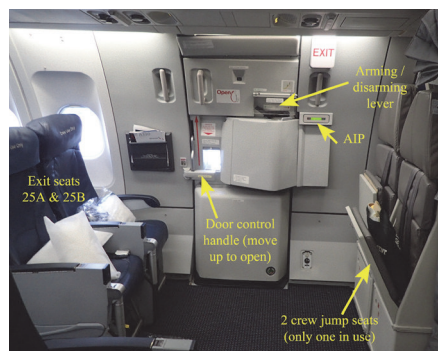

[Safety Recommendation 2017-028](#) made on 7 December 2017

N276AY Airbus A330-323 on 26 June 2016

It is recommended that the European Aviation Safety Agency require cabin crew on aircraft that are parked and with passengers on-board to be evenly distributed throughout the cabin and in the vicinity of floor-level exits, in order to provide the most effective assistance in the event of an emergency.



Adequate - Closed

[Safety Recommendation 2017-029](#) made on 7 December 2017

N276AY Airbus A330-323 on 26 June 2016

It is recommended that the Federal Aviation Administration require that flight and cabin crew participate in joint training to enhance their co-ordination when dealing with emergencies.



Response Awaited - Open

Safety Actions from investigations reported on in 2017

Early in an investigation the AAIB will engage with authorities and organisations which are directly involved and have the ability to act upon any identified safety issues. The intention is to prevent recurrence and to that end to encourage proactive action whilst the investigation is ongoing and not for those involved to wait for the issue of official Safety Recommendations.

When safety action is taken, it may mean there is no need to raise a Safety Recommendation as the safety issue may have been addressed. However, if the issue remains then a Safety Recommendation will be raised. The published report details the safety issues and the safety action that has taken place, usually with a green highlight. In 2017 safety actions directly as a result of AAIB investigations were recorded on two formal investigations, eighteen field investigations and seventeen correspondence investigations.

SPECIAL BULLETIN

[Sikorsky S-92A, G-WNSR on 28 December 2016](#)

Safety issue – HUMS procedures, component failure, airworthiness

The operator

The operator has subsequently introduced a number of measures to further strengthen the ability to detect impending bearing degradation. These include: a review of all HUMS data to ensure no anomalies, fleet-wide borescope inspections, a requirement for HUMS to be serviceable before flight and the time between HUMS download/analysis reduced to a maximum of 5 hours. The operator has also reviewed their HUMS processes and analytical procedures and introduced a requirement to carry out an additional assurance check.

The helicopter manufacturer

On 31 December 2016, the helicopter manufacturer issued to all operators an 'All Operators Letter' (AOL), CCS-92-AOL-16-0019, which described the event. It emphasises the use of the HUMS Tail Gearbox Bearing Energy Tool, provided on the ground station, which will detect a TRPCS bearing that is experiencing degradation, and recommends that this Tool should be utilised as often as reasonably possible.



This was followed by an Alert Service Bulletin (ASB) issued by the manufacturer on 10 January 2017. ASB 92-64-011 introduces a one-time inspection of the TRPCS and bearing assembly for ratcheting, binding, or rough turning. The manufacturer has recommended that compliance is essential and is to be accomplished prior to the next flight from a maintenance facility; three flight hours are

allowed in order to return directly to a maintenance facility. Concurrent with the release of ASB 92-64-011, the manufacturer published Temporary Revision 45-03 to require operators to use S-92 HUMS ground station software to review Tail Rotor Gearbox energy analysis Condition Indicators for alert conditions on a reduced flight hour interval. Records in excess of published alert levels require inspection of the pitch change shaft and bearing.

FIELD INVESTIGATIONS

[Hawker Sea Fury T Mk 20, G-RNHF on 31 July 2014](#)

Safety issue – Historic aircraft airworthiness and maintenance

Various marks of the Centaurus engine are still in use in a small number of aircraft but findings in this case could equally apply to other radial and inline aero-engine types. Based on this, the CAA has undertaken to publish a Safety Notice aimed at the historic aircraft community, to draw attention to the issues and difficulties of maintaining airworthiness of aging aircraft engines and their associated components.

[Saab 2000, G-LG NR on 6 November 2015](#)

Safety issue – checklist unintended result, reduced control

The manufacturer stated that it intended to add the following to the ‘Aileron system open failure’ section of the malfunction checklist at the next AOM revision: “NOTE: Verify an open failure by visually observing that one of the ailerons do not follow control wheel input.”

[ATR 72-212 A, G-COBO on 4 March 2016](#)

Safety issue – effects of icing, pre-flight inspection and training

The ATO responsible for the pilot’s type conversion training is adjusting its conversion course to align with the EASA Operational Suitability Data report. This is being achieved by incorporating the manufacturer’s simulator profile for a badly de-iced tailplane.

The operator has enhanced its winter awareness training for pilots by purchasing a computer-based training module. All pilots will complete this before each winter season and their knowledge will be tested as part of the process.

The operator’s conversion courses are being extended through the inclusion of a ground training day, with a training captain, prior to the start of Line Flying Under Supervision. This is to ensure time is spent discussing, in detail, technical issues relating to line operations. Winter operations and de-icing/anti-icing will be among the topics covered.



The operator provided the co-pilot with additional training before he was allowed to resume line flying duties.

The operator is reviewing its requirements for aircraft inspections following use of thickened de-icing fluids.

The operator intends to provide better guidance for the aftermath of a serious incident by making changes to its Operations Manual (Part A). This is likely to include a recommendation for a group debrief to take place as a matter of course, so the crew can discuss what happened and what they have learnt.

The manufacturer has stated it will contact all operators prior to the start of the next European winter, to promote awareness of the circumstances which led to this serious incident.

Airbus A319-111, G-EZFJ on 14 April 2016

Safety issue – EFB software anomaly, potential cockpit display confusion

- The operator sent an email to all pilots on 22 April 2016 highlighting this specific anomaly.
- The MRC function was disabled across the operator's fleet in May 2016.
- The operator has reviewed and proposed further modification to their SOPs.
- In the L6.x versions of FlySmart, it has been verified by the manufacturer that the MRC function is not affected by this anomaly.
- The manufacturer has sent Flysmart Communication reference X46D16018565 to operators highlighting the anomaly discovered during this investigation and recommending that the affected operators disable the MRC option.
- The manufacturer sent Flight Operations Transmission (FOT) 999.0095/16 to all operators reminding them of the manufacturer's recommended procedures for EFB use. This involves each crew member performing their own independent calculations, the results of which are then cross-checked.

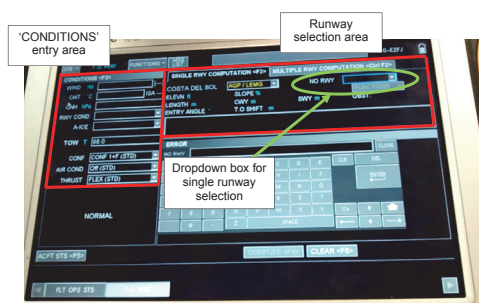

Rans S6-ESD (Modified) Coyote II, G-MYES on 30 May 2016

Safety issue – Low speed handling, pilot information and airfield markings

As a result of the rate of stall/spin accidents involving Rans S6 aircraft in the UK, the LAA has undertaken to conduct a safety review encompassing the following aspects:

- *‘Complete a review of accident data with the type to date, including consideration of the aircraft configuration, weights and cg positions, mission and pilot profiles of those involved, including a comparison with the accident data for similar types of microlight*
- *Carry out a flight test program on at least two representative examples, to investigate possible handling, performance or other factors that might contribute to an elevated accident rate, including:*
 - *Longitudinal stability*
 - *Ability to trim (in pitch)*
 - *Longitudinal and lateral/directional trim changes with changes in power and configuration (i.e. flap position)*
 - *Directional stability and control, including contributing effects of adverse yaw with aileron input, and any contributing ergonomic aspects*
 - *Pre-stall warning*
 - *Stall characteristics*
 - *Ease of operation of controls*
 - *Adequacy of low-speed stall recovery/ climb performance at different weights and centre of gravity positions*
 - *Behaviour in a simulated engine failure*
 - *Instrumentation, in particular, adequacy of indication of airspeed and slip’*

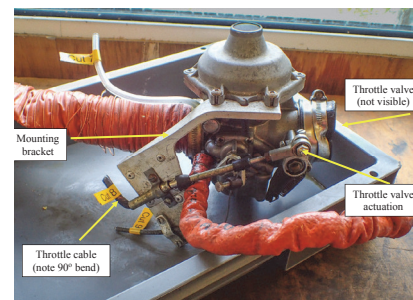

The LAA has advised that the applicable paragraphs of BCAR Section S, both current and extant at the time the type was introduced to the UK, are being used as the basis for this evaluation. The results of the safety review will be communicated to all Rans S6 pilots within the LAA membership

The LAA has also undertaken to produce a series of pilot's notes for the Rans S6, tailored to each airframe/engine combination on the UK fleet, on completion of the flight tests. The relevant Rans S6 TADS will be updated accordingly.

Flying club

Recognising the possibility of future confusion, the flying club at Shifnal Airfield reported that it had removed the landing T and signal square, to prevent incorrect signals being displayed.

Airbus A330-323, N276AY on 26 June 2016

Safety issue – Emergency evacuation procedures, master minimum equipment list (M MEL) guidance and component maintenance policy

Operator

All pilots were informed that an evacuation should only be halted by the commander if he ‘has clear information that continuation of the evacuation would cause greater injury’.

Studies of the interphone equipment on different aircraft types confirmed a need to refine the communication process on certain types. On the Airbus A319, A320, A321 or A330-300, FAs should now press the EMER CALL button once to contact the flight deck in an emergency. On the Airbus A330-200 they should press the PRIO CAPT button and on the Embraer E190 the EMER PILOT button.



A video was produced with the co-operation of the crew involved in this occurrence, to highlight the issues they experienced. This video is being used as an educational tool for all pilots during their recurrent Human Factors (HF) training, for the nine month cycle commencing 1 February 2017. It may also become possible to use this video during FA training.

A type-specific ‘Emergency Deplaning’ drill has been developed for use by pilots on each of the operator’s aircraft types and incorporated into the OM and the appropriate QRH. This drill is relevant to parked aircraft that are using a jetbridge or steps. Details were promulgated to all crews and pilots received relevant simulator training.

As there is no commonality between the cabin interphone handsets on different aircraft types, a physical training aid is being developed for use during initial and recurrent FA training. This is intended to give FAs a better understanding of the differences they will encounter and to help them adapt to any of the 14 aircraft types or variants on which they can be qualified.

Recurrent HF training for the aircraft operator’s 12,000 pilots takes place on a 9 month cycle. The 27,000 FAs are on a 12 month cycle. This makes it difficult to conduct joint evacuation training with entire crews, so the operator is considering having pilot representatives participate in FA training and vice-versa. Future recurrent training for both pilots and FAs will focus on unplanned cabin evacuations when the aircraft is not on the runway.

The Continuing Qualification training given to all FAs between April 2017 and March 2018 includes a review of an ‘Emergency Deplaning’ and it is likely attendees will hear the specific aural alert signals for each aircraft type.

The operator expects a company safety investigator to contact the commander by telephone as soon as its 'Dispatch' department has been advised of a serious incident or accident. The safety investigator is now required to remind the commander during this contact that action be taken to ensure the circuit breaker for the CVR is pulled without delay.

Training procedures were developed for the aircraft operator's ramp personnel, to ensure they know how best to react if a slide evacuation occurs while an aircraft is parked.

Twice a year, US operators, along with some foreign airlines that operate to the US, share experiences at a safety forum. The operator intends to discuss issues raised by this event at such a forum; to raise the industry's awareness of the challenges that can be created by a cabin evacuation from a parked aircraft.

Aircraft manufacturer

The aircraft manufacturer has reviewed and amended the MMEL section 24-23-01, for the dispatch of an aircraft with APU AC auxiliary generation unserviceable and a summary of these changes is as follows:

MMEL item 24-23-01A 'APU not used':

No change, as not relevant to the event.

MMEL item 24-23-01B 'Electrical failure':

To insure a more robust detection of a mechanical failure, a review has been conducted with the APU Generator supplier and the following 4 failure messages will be added to the list from the AMM task 24-23-00-040-803.

- GEN APU (8XS)
- GEN APU (8XS) EX FLD / GAPCU (40XG)
- GAPCU (40XG) EX FLD / GEN APU (8XS)
- GEN APU (8XS) EX FLD / GAPCU (40XG)

If any of these messages is present in the PFR when doing the interactive APU test, then the MMEL 24-23-01C must be applied.

MMEL item 24-23-01C 'AC auxiliary generation deactivated or removed (mechanical failure)':

An update of the related AMM tasks (e.g. 24-23-00-040-801 and -802) has been decided, to prevent oil cross-contamination from the APU Gen to the APU. The AMM TASK 49-91-41-210-802-A "Check of the APU Oil System for APU Generator

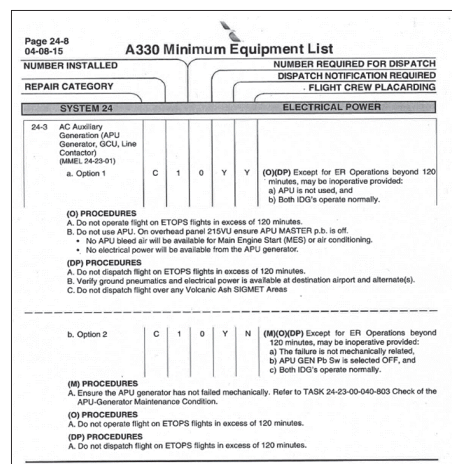

NUMBER INSTALLED	REPAIR CATEGORY	DISPATCH NOTIFICATION REQUIRED	FLIGHT CREW PLACARDING
SYSTEM 24 ELECTRICAL POWER			
24-3	AC Auxiliary Generator (APU Generator, GCU, Line Contactor) (MMEL 24-23-01)		
a. Option 1	C	I	O
		Y	Y
<p>(O) PROCEDURES A. Do not operate flight on ETOPS flights in excess of 120 minutes. B. Do not use APU. On overhead panel 215VU ensure APU MASTER p.b. is off. • No APU bleed air will be available for Main Engine Start (MES) or air conditioning. • No electrical power will be available from the APU generator.</p> <p>(DP) PROCEDURES A. Do not dispatch flight on ETOPS flights in excess of 120 minutes. B. Verify ground pneumatics and electrical power is available at destination airport and alternate(s). C. Do not dispatch flight over any Volcanic Ash SIGMET Areas.</p>			
b. Option 2	C	I	O
		Y	N
<p>(M) PROCEDURES A. Ensure the APU generator has not failed mechanically. Refer to TASK 24-23-00-040-803 Check of the APU-Generator Maintenance Condition.</p> <p>(O) PROCEDURES A. Do not operate flight on ETOPS flights in excess of 120 minutes.</p> <p>(DP) PROCEDURES A. Do not dispatch flight on ETOPS flights in excess of 120 minutes.</p>			

Debris” has been added at the end of those tasks, and must be carried out prior to aircraft dispatch. This AMM task includes a physical check of the APU oil system (inlet screens of the scavenge-oil, inspection of the magnetic chip detectors and the mechanical differential pressure indicator, check of the lubrication oil supply and generator scavenge filters).

Yak-52, G-YAKB on 8 July 2016

Safety issue – Smaller (less than 400 hp) historic engines overhaul policy

The CAA have stated that they are conducting a review of engine maintenance to determine if Leaflet 70-80 should be extended to all piston engines and whether any Alternative Means (Methods) of Compliance arising from Leaflet 70-80 should be made mandatory by means of a Mandatory Permit Directive (MPD). This will also include a review of Generic Requirement No. 24 in CAP 747.

Druine D.31 Turbulent, G-ARNZ on 14 August 2016

Safety issue – Aircraft system design

The operators of the aircraft developed a modification to fit a screen to the engine’s carburettor intake, with the intention of preventing the ingress of similar debris to the balloon fragment. Should this screen become blocked, air can still be supplied to the carburettor via the alternative hot air supply, thereby allowing the engine to operate normally. After satisfactory testing, the modification was approved by the Light Aircraft Association.



Spitfire IXT, G-LFIX on 15 September 2016

Safety issue – Cockpit indicator visibility

In order to prevent the illumination of the complete word “DOWN” in the landing gear position indicator in the event that one landing gear has not achieved the fully locked position, the maintenance organisation modified the landing gear indicator to prevent light from either of the indicator bulbs illuminating the complete DOWN caption.

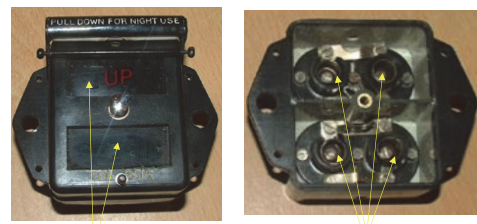

Westland Wasp HAS1, G-KAXT on 23 September 2016

Safety issue – Continued airworthiness of historic aircraft and servicing policy

The investigation findings were highlighted to the CAA at an early stage. The CAA took urgent action to ensure the continued airworthiness of Westland Wasp and Scout helicopters on the UK register by issuing Emergency Mandatory Permit Directive (EMPD) No 2017-002-E. (<http://publicapps.caa.co.uk/modalapplication.aspx?appid=11&mode=detail&id=7759>)

The EMPD requires operators to perform a visual check of the condition of the universal joint and conduct periodic lubrication of the joint.

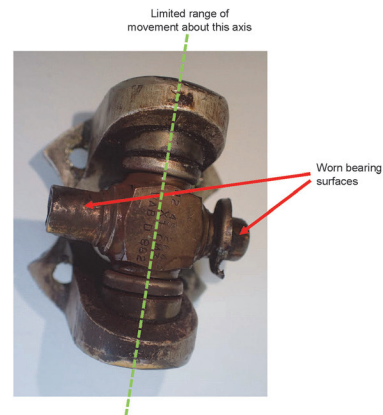

Airbus A319-131, G-EUPM on 19 October 2016

Safety issue – CVR/FDR data preservation

Following this event, the operator of G-EUPM made changes to its procedures to ensure that the commander is aware of his responsibility to ensure that the recordings are preserved.

Airbus A320-214, G-EZWX on 28 November 2016

Safety issue - Component malfunction, OEM information and crew awareness

- By 9 December 2016, the operator of G-EZWX had removed all affected static inverters from its fleet and those that were held as spares.
- The operator's engineering department is now reviewing all TFUs on a routine basis.

Further safety action

- The aircraft manufacturer has advised that, later in 2017, it will release an Inspection Service Bulletin (ISB) to assist operators in identifying and rectifying any of the affected static inverters.
- The aircraft manufacturer has also advised that it will provide additional information to operators on the operation of the emergency interphone system.
- The operator has advised that, following the provision of the additional information of the emergency interphone system from the aircraft manufacturer, it will include this as part of crew training and update the appropriate internal manuals.
- The operator has also advised that it intends to conduct a review of its processes that relate to VSBs.



ATR 72-212 A, 500 Version, G-COBO on 21 December 2016

Safety issue – Operating procedures, crew response

Operator

The operator reviewed its ATR procedures and amended them to improve safeguards against similar occurrences. Flight crews were reminded of the required response to APM cautions, and the operator now replicates this incident, and APM messages, during pilots' flight simulator training. Several internal recommendations were made, addressing non-normal situation handling in general.

The following *FLYING STAFF INSTRUCTION – ATR* was issued on 28 December 2016, with an amendment to the ATR Operations Manual Part B, Section 2.4:

‘2.4.16.2 Climb Speed

Standard Climb Speed is 170 kt IAS or Red Bug + 10 kt, whichever is the higher, achieved using AFCS [Automatic Flight Control System] IAS mode.

Climb speed may only be reduced below 170 knots if required for terrain clearance or mandatory ATC requirements. Under these circumstances the minimum IAS is White Bug + 10 kt in Normal Conditions and Red Bug + 10 kt in Icing Conditions.

...

If during climb at Standard Climb Speed the average rate of climb falls below 500 feet per minute, crews should request to stop climb at the next available level or advise ATC of the reduced climb capability. Speed must not be reduced to maintain a given rate of climb.’

The following memo was sent to all ATR pilots:

‘APM / Reduced Performance

Crews are also reminded that Severe Icing may be encountered without the presence of the normally associated visual cues, and reduced rate of climb or cruise airspeed are sometimes the only indication of significant ice accretion. Whenever crews encounter or suspect severe icing, the full checklist at QRH page 1.09 [Severe Icing] must be completed.

Aircraft manufacturer

The aircraft manufacturer stated that it is working to improve the APM to avoid the illumination of cautions that are perceived as spurious.

As a result of this occurrence and that investigated by the AIBN the manufacturer has amended the DEGRADED PERF and SEVERE ICING procedures.



The amended DEGRADED PERF procedure will state that the SEVERE ICING procedure should be actioned if the aircraft is unable to maintain a climb rate greater than 100 ft/min, when climbing at red bug +10 kt. The SEVERE ICING procedure will have fewer memory items and will state that, after IAS and engine power are increased and the autopilot is disconnected, a descent is to be initiated to escape the severe icing conditions.

The amendments, in the appropriate documents, are due to be distributed to all operators in January 2018.

The manufacturer of this aircraft, together with other aircraft manufacturers, has contributed to the update of the Airplane Upset Prevention and Recovery Training Aid (AUPRTA), Revision 3, which is available on ICAO website. This update includes information specific to turboprop aircraft.

[Boeing 737-36E Freighter, TF-BBF on 3 February 2017](#)

Safety issue - Component failure

The operator is replacing the V-band clamps at the failure location on TF-BBF across its fleet of 737-300 and 737-400 aircraft. This is being carried out on a rolling programme, as the aircraft undergo scheduled C-check maintenance inspections. The operator is also considering replacement of other V-band clamps on their aircraft where the release of bleed air may create a hazard.



[Europa, G-NDOL on 28 May 2017](#)

Safety issue – Modification standard, system integrity

On 19 July 2017, the LAA issued Airworthiness Information Leaflet LAA/MOD/247/010. This required a mandatory inspection, before next flight, of all Europa aircraft operating under an LAA administered Permit to Fly. The inspection was to check for the correct installation of a fuel vapour return line. Details can be found on the [LAA website](#).

CORRESPONDENCE INVESTIGATIONS

[Robinson R44 II, G-SAIG and Spitfire IX, G-CCCA on 15 June 2016](#)

Safety issue – airfield movements deconfliction

After the accident, the Aerodrome Safety Manager issued a safety notice to the helicopter operator based at the airfield, requiring helicopters to hold short of the active runway and request clearance to cross. The A/G radio operator will then inform the helicopter pilot of any known traffic and the pilot, having checked it is safe to do so, may then cross the runway.

Europa XS, G-BYSA on 10 August 2016

Safety issue – Airfield information

The airfield operator has informed the publishers of various flight guides that the runway width is now 10 m and requested that they include a warning to ‘Beware cliffs on the east side of the airfield’.

The Light Aircraft Association included this accident in their October 2016 ‘Safety Spot’ feature to advise their members of the circumstances.



Flight Design CTSW, G-CGVG on 8 October 2016

Safety issue – Airworthiness and NDT servicing policy

In response to this accident the UK agent intends to issue Service Bulletin CT145, which requires removal and dye penetrant crack inspection of the main landing gear legs of all CT2K and CTSW aircraft at intervals of 300 flying hours. Service Bulletin CT145 will supersede SB CT123. Service Bulletin CT145 will also introduce modification M309, in which the edges of the main attachment hole in the legs are peened, leaving residual compression stress at the hole edges intended to suppress fatigue crack initiation. Service Bulletin CT145 continues to include the requirement to inspect the legs for cracks and straightness following heavy landing events.

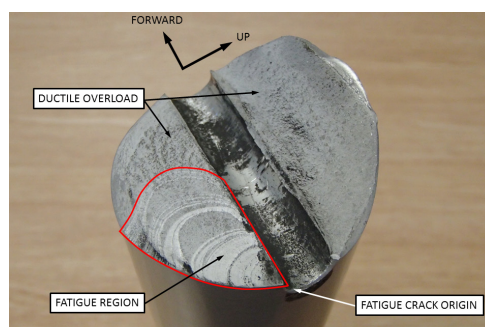

Eurofox 912(LS), G-ODGC on 15 October 2016

Safety issue – Component fatigue, lifing policy and airworthiness

As a result of the incident and discussions with the LAA, on 1 November 2016 the aircraft manufacturer issued Mandatory Service Bulletin, EuroFOX SB 03/2016 LAA (v2). This required the replacement of the landing gear mounting bolts within 20 flying hours of the release date of the Bulletin and introduced a 500 flying-hour mandatory life on the bolts. On 4 November 2016, the LAA published Airworthiness Alert LAA/AWA/16/07 which detailed the failure and alerted operators of the aircraft to the requirements of the Mandatory Service Bulletin. The incident was also publicised in the LAA’s November 2016 Safety Sense article.

UAS Schiebel Camcopter S-100 (unregistered) on 18 October 2016

Safety issue – Human factors, workload and control logic

The manufacturer has implemented a software change to reduce operator workload during takeoff. If the UA is on the ground and the trim mode has been selected:

- Operator thumb rocker climb-rate inputs between -50% and +50% produce an automatic climb rate command of +50% until the trim becomes active, and
- All cyclic joystick inputs are ignored until the trim becomes active.

Dassault Falcon 7X, VQ-BSO on 24 November 2016

Safety issue – Aircraft ground handling and observation

London City Airport identified the following safety actions:

1. The parking positions for the Falcon 7X should be identified and the position of their main and nose wheels marked on the apron surface.
2. All the Jet Centre's marshallers should receive refresher training on the correct ICAO marshalling signals.
3. Marshalling wands must be used for all manoeuvring not just at night or in reduced visibility.
4. Initially, marshallers and 'wing walkers' would be equipped with belt mounted horns to provide an audio STOP signal. This would subsequently be replaced providing digital radios on a dedicated frequency.
5. A new supervisory level appointment would be created to oversee all parking.'

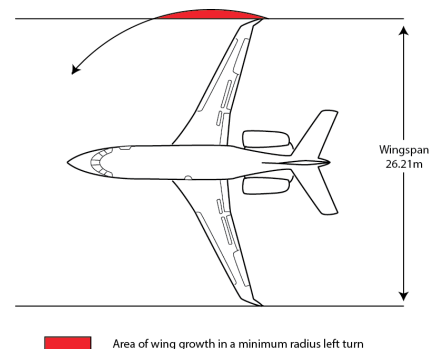

Robin DR400/180 Regent, G-ETIV on 7 December 2016

Safety issue – CRM, spatial awareness and airfield knowledge

Following an investigation, a safety action was taken at the airfield to ensure pilots are told the runway in use when they call on the radio prior to arrival.

In May 2017, the CAA published CAP 1535, 'The Skyway Code' which is intended to provide General Aviation pilots involved in non-commercial and flight training operations



with practical guidance on the operational, safety and regulatory issues relevant to their flying. ‘The Skyway Code’ includes a section on the responsibilities of the Pilot in Command in a format which is intended to be more accessible than from regulatory documents.

To further clarify the term ‘Safety Pilot’ when used with an ‘Operational Safety Pilot Limitation (OSL)’ placed on a Medical Certificate, the CAA will produce an article for ‘Clued Up’, its magazine for the general aviation community. Additionally, the CAA will also ask the General Aviation Safety Council (GASCO) to publish the same article in its Flight Safety Bulletin.

[DHC-8-402, Dash 8, G-FLBB on 8 December 2016](#)

Safety issue – Component history and reliability

The operator has expressed concerns over the reliability of the outflow valve and has initiated a reliability investigation involving the spare part provider and the OEM. At the time of writing the results of the reliability investigation are not known.

[Piper PA-28-181 Cherokee Archer II, G-BPAY on 29 December 2016](#)

Safety issue – Ground movements, parking and observation

Since the accident the airfield operator has changed its procedures to reduce the need for parallel rows of parked aircraft and therefore lessen the risk of ground collisions.

[Agusta AW139, G-VINB on 20 January 2017](#)

Safety issue – Flight planning and CRM

The operator carried out a prompt internal investigation into the incident and identified a number of potential safety actions. The following are of relevance to this report:

Carry out a Flight Planning Software review for robustness and ease of use.

Carry out a review of the destination nomenclatures used for planning applications and software.

Reiterate to all crews the importance of clear and unambiguous communications.

Reiterate to crews the importance of re-briefing all aspects of the flight when a significant change has been applied.’

The remaining sectors were completed without incident.



Bell 206B Jet Ranger III, G-BTHY on 19 February 2017

Safety issue – Air space use and NOTAM requirements

The operator has advised its pilots of the potential hazard of high flying kites and the need to avoid areas where they suspect the activity is taking place.

The CAA has been advised of the activity and an investigation is being conducted. The incident has also been reviewed by the CAA Safety Risk Panel.

Airbus A320-214, G-EZTV on 3 March 2017

Safety issue – Aircraft ground handling procedures and equipment knowledge

There have been several safety actions made by three organisations as a result of this accident. These are outlined below.

The ground handling company has instigated several changes to its procedures and to personnel training, including:

Improvements to towbar maintenance and inspection procedures.

A training aid has been developed to help ground crew recognise when shear pins are unserviceable.

A standard fault-finding procedure has been introduced for ground crews when they hear an unusual sound or suspect a shear pin has broken while pushing or pulling an aircraft.

Improvements have been made to ground crew training to ensure that correct procedures for aircraft engine start are followed for each stand at Manchester.

The airfield operator has issued safety alerts to airfield users regarding inspections and maintenance of pushback equipment and regarding stand-specific pushback procedures.

The aircraft operator has reviewed its pushback procedures in response to the aircraft manufacturer's comments.



Airbus A320-214, G-EZTM on 26 March 2017

Safety issue – Aircraft ground movements and support procedures

The operator's engineering department is reviewing the AMM task (324200710001-A Rev.55) and will make recommendations to the aircraft manufacturer to amend the AMM accordingly.

The ground handling company has undertaken the following actions to prevent a recurrence:

1. Raised awareness of the event;
2. Retrained the staff involved concerning the correct chocking procedures;
3. The defective equipment local operating procedure has been re-issued to all staff to prevent inoperative equipment being available for use.

Agusta A109S Grand, G-PBWR on 5 May 2017

Safety issue – Airworthiness, left horizontal stabiliser failure

Prompted by this event, the manufacturer issued a Service Bulletin providing new instructions for a one-time inspection and new repetitive inspections at a reduced inspection threshold and interval. As a result of this and its own safety assessment, EASA issued Emergency Airworthiness Directive AD 2017-0085-E, on 12 May 2017, to mandate these instructions.



Reims Cessna F406 Caravan II, G-RVLX on 1 June 2017

Safety issue – Hatch and door security, crew aircraft knowledge

The operator is taking the following safety actions:

An email was sent to all crew to notify them of the event and to highlight correct door operation and security

A fleet check of aircraft fitted with a similar door was carried out to ensure that both primary and secondary locks operated correctly.

Placarding of the secondary handle will be improved to clearly identify when it is the LOCKED position.

A strap will be fitted to the emergency exit main handle to minimise the likelihood of it being inadvertently disturbed.

Cessna 510 Citation Mustang, OE-FHK on 15 June 2017

Safety issue – Aircraft system knowledge

The aircraft operator has taken the following Safety Actions;

A 'Safety Bulletin' to flight crew was circulated which stated that the parking brake is only to be set with the battery switch in the BATT position and that the appropriate checklists are always to be followed. This notice also warns crew not to remove chocks if there are obstacles such as a fuel bowser nearby and states that trainee pilots are always to be accompanied by an experienced crew member while operating the aircraft.



The SOPs were modified and additional guidance on operation of the parking brake and the use of wheel chocks was placed in the OM.

Pilot training was revised to try to ensure a comprehensive understanding of the hydraulic system and the aircraft brakes.

Quest Q-200 UAS on 12 July 2017

Safety issue - Commercial UAV operating procedures

The operator has made the following procedural changes to minimise the probability of collisions with high obstacles on this and other construction sites:

Construction site staff will be contacted, prior to launch, to check the height of the highest structure to ensure that sufficient clearance can be met. If this cannot be achieved that part of the site will not be overflowed.



Any flights that have the potential to overfly the construction site will be flown at 400 ft.

Manual corrective action will be taken to manoeuvre the UA in the event of deviations from the flight plan.

AW109SP Grand New, G-HLCM on 2 August 2017

Safety issue - Rotor blade integrity and airworthiness

The manufacturer identified the main rotor blades that were potentially affected and issued Service Bulletin 109SP-116 to introduce a periodic inspection.

The EASA issued Emergency Airworthiness Directive 2017-0176-E to mandate the requirements of the Service Bulletin.

Appendix 1 - CICITT Occurrence Categories

CODE	DESCRIPTION
ARC	ABNORMAL RUNWAY CONTACT
AMAN	ABRUPT MANEUVER
ADRM	AERODROME
MAC	AIRPROX/TCAS ALERT/LOSS OF SEPARATION/NEAR MIDAIR COLLISIONS/MIDAIR COLLISIONS
ATM	ATM/CNS
BIRD	BIRD
CABIN	CABIN SAFETY EVENTS
CTOL	COLLISION WITH OBSTACLE(S) DURING TAKEOFF AND LANDING
CFIT	CONTROLLED FLIGHT INTO OR TOWARD TERRAIN
EVAC	EVACUATION
EXTL	EXTERNAL LOAD RELATED OCCURRENCES
F-NI	FIRE/SMOKE (NON-IMPACT)
F-POST	FIRE/SMOKE (POST-IMPACT)
FUEL	FUEL RELATED
GTOW	GLIDER TOWING RELATED EVENTS
GCOL	GROUND COLLISION
RAMP	GROUND HANDLING
ICE	ICING
LOC-G	LOSS OF CONTROL-GROUND
LOC-I	LOSS OF CONTROL-INFLIGHT
LOLI	LOSS OF LIFTING CONDITIONS EN ROUTE
LALT	LOW ALTITUDE OPERATIONS
MED	MEDICAL
NAV	NAVIGATION ERRORS
OTHR	OTHER
RE	RUNWAY EXCURSION
RI	RUNWAY INCURSION
SEC	SECURITY RELATED
SCF-NP	SYSTEM/COMPONENT FAILURE OR MALFUNCTION (NON-POWERPLANT)
SCF-PP	SYSTEM/COMPONENT FAILURE OR MALFUNCTION (POWERPLANT)
TURB	TURBULENCE ENCOUNTER
USOS	UNDERSHOOT/OVERSHOOT
UIMC	UNINTENDED FLIGHT IN IMC
UNK	UNKNOWN OR UNDETERMINED
WILD	WILDLIFE
WSTRW	WIND SHEAR OR THUNDERSTORM

GLOSSARY OF ABBREVIATIONS

aal	above airfield level	lb	pound(s)
ACAS	Airborne Collision Avoidance System	LP	low pressure
ACARS	Automatic Communications And Reporting System	LAA	Light Aircraft Association
ADF	Automatic Direction Finding equipment	LDA	Landing Distance Available
AFIS(O)	Aerodrome Flight Information Service (Officer)	LPC	Licence Proficiency Check
agl	above ground level	m	metre(s)
AIC	Aeronautical Information Circular	MDA	Minimum Descent Altitude
amsl	above mean sea level	METAR	a timed aerodrome meteorological report
AOM	Aerodrome Operating Minima	min	minutes
APU	Auxiliary Power Unit	mm	millimetre(s)
ASI	airspeed indicator	mph	miles per hour
ATC(C)(O)	Air Traffic Control (Centre)(Officer)	MTWA	Maximum Total Weight Authorised
ATIS	Automatic Terminal Information Service	N	Newtons
ATPL	Airline Transport Pilot's Licence	N _R	Main rotor rotation speed (rotorcraft)
BMAA	British Microlight Aircraft Association	N _g	Gas generator rotation speed (rotorcraft)
BGA	British Gliding Association	N ₁	engine fan or LP compressor speed
BBAC	British Balloon and Airship Club	NDB	Non-Directional radio Beacon
BHPA	British Hang Gliding & Paragliding Association	nm	nautical mile(s)
CAA	Civil Aviation Authority	NOTAM	Notice to Airmen
CAVOK	Ceiling And Visibility OK (for VFR flight)	OAT	Outside Air Temperature
CAS	calibrated airspeed	OPC	Operator Proficiency Check
cc	cubic centimetres	PAPI	Precision Approach Path Indicator
CG	Centre of Gravity	PF	Pilot Flying
cm	centimetre(s)	PIC	Pilot in Command
CPL	Commercial Pilot's Licence	PNF	Pilot Not Flying
°C,F,M,T	Celsius, Fahrenheit, magnetic, true	POH	Pilot's Operating Handbook
CVR	Cockpit Voice Recorder	PPL	Private Pilot's Licence
DME	Distance Measuring Equipment	psi	pounds per square inch
EAS	equivalent airspeed	QFE	altimeter pressure setting to indicate height above aerodrome
EASA	European Aviation Safety Agency	QNH	altimeter pressure setting to indicate elevation amsl
ECAM	Electronic Centralised Aircraft Monitoring	RA	Resolution Advisory
EGPWS	Enhanced GPWS	RFFS	Rescue and Fire Fighting Service
EGT	Exhaust Gas Temperature	rpm	revolutions per minute
EICAS	Engine Indication and Crew Alerting System	RTF	radiotelephony
EPR	Engine Pressure Ratio	RVR	Runway Visual Range
ETA	Estimated Time of Arrival	SAR	Search and Rescue
ETD	Estimated Time of Departure	SB	Service Bulletin
FAA	Federal Aviation Administration (USA)	SSR	Secondary Surveillance Radar
FDR	Flight Data Recorder	TA	Traffic Advisory
FIR	Flight Information Region	TAF	Terminal Aerodrome Forecast
FL	Flight Level	TAS	true airspeed
ft	feet	TAWS	Terrain Awareness and Warning System
ft/min	feet per minute	TCAS	Traffic Collision Avoidance System
g	acceleration due to Earth's gravity	TGT	Turbine Gas Temperature
GPS	Global Positioning System	TODA	Takeoff Distance Available
GPWS	Ground Proximity Warning System	UAS	Unmanned Aircraft System
hrs	hours (clock time as in 1200 hrs)	UHF	Ultra High Frequency
HP	high pressure	USG	US gallons
hPa	hectopascal (equivalent unit to mb)	UTC	Co-ordinated Universal Time (GMT)
IAS	indicated airspeed	V	Volt(s)
IFR	Instrument Flight Rules	V ₁	Takeoff decision speed
ILS	Instrument Landing System	V ₂	Takeoff safety speed
IMC	Instrument Meteorological Conditions	V _R	Rotation speed
IP	Intermediate Pressure	V _{REF}	Reference airspeed (approach)
IR	Instrument Rating	V _{NE}	Never Exceed airspeed
ISA	International Standard Atmosphere	VASI	Visual Approach Slope Indicator
kg	kilogram(s)	VFR	Visual Flight Rules
KCAS	knots calibrated airspeed	VHF	Very High Frequency
KIAS	knots indicated airspeed	VMC	Visual Meteorological Conditions
KTAS	knots true airspeed	VOR	VHF Omnidirectional radio Range
km	kilometre(s)		
kt	knot(s)		