

**OPINION UNDER SECTION 74A**

Patent	GB 2507071 B
Proprietor(s)	Shaun Spurrell
Exclusive Licensee	
Requester	RCR Flooring Ltd
Observer(s)	Shaun Spurrell
Date Opinion issued	15 February 2018

**The request**

1. The Comptroller has received a request from RCR Flooring Limited (the requester) to issue a validity opinion under section 74A(1)(b) in respect of patent GB 2507071B (the patent) in the name of Shaun Spurrell (the proprietor). The request questions the validity of the patent on the basis that it is not novel, is obvious, contains added matter and does not disclose the invention clearly and completely enough.
2. The Patent has a filing date of 17 October 2012. It was granted on 4 July 2017 and remains in force.
3. Observations were filed on behalf of the proprietor and observations in reply were subsequently received from the requester.

**Preliminary matters**

4. The requester has argued that the patent lacks novelty on the basis (amongst others) of two patent documents DE 20 2009 000 007 U1 (HAMMES) and EP 1,389,648 A1 (PERMABAN). However, both documents were considered by the examiner pre-grant as third party observations. In accordance with the established practice of the Office<sup>1</sup>, such documents will not be considered as part of an opinion unless they raise a new question. Save for in exceptional circumstances, the proprietor is not expected to re-address, as part of an opinion, a document considered as part of the examination of the application.
5. In relation to EP 1,389,648 the requester only seeks to rely on it to show that certain features were known in order apparently to establish lack of inventive step when combined with the other new prior art. As such there is a *prima facie* new question in relation to it and this document will be considered as necessary on that limited basis.

---

<sup>1</sup> See decisions BL O/370/07, BL O/289/07 and BL O/298/07.



after casting to reinforce the joint between adjacent slabs, these elements becoming embedded in the concrete. The particular feature of the invention lies in the provision of the extension (2) connected to the divider plate by means of slots (3) in the extension cooperating with fixings (4) attached to the divider plate. In particular, the extension and divider plate are connected together loosely so that the extension is able to slide freely up and down whilst still being restrained from any additional movement by the fixings.

11. In use the top of the joint must be flush with the top of the concrete slab. It is therefore necessary to support the joint in some way to achieve the correct depth of slab whilst maintaining the top flush. Prior art joints are typically of a fixed height and, in order to accommodate variations in the level of the subbase, are sized slightly smaller than the depth of concrete required, such that when supported at the correct height there is a gap between the bottom of the joint and the surface of the subbase through which wet concrete may seep. The extension of this invention is intended to bridge the gap and prevent concrete seeping under the joint.

12. Claim 1 of the patent (the only independent claim) reads as follows:

*Apparatus for forming an edge of a concrete floor slab panel laid on a subbase, the apparatus comprising:*

*a divider plate for bounding a side of the slab panel, the divider plate having first and second faces; and*

*an elongate extension, securable along the first face of the divider plate, for sliding extension to an extended position in which the extension bridges a gap between the divider plate and the subbase in use,*

*wherein the longitudinal axis of the elongate extension is, in use, positioned substantially parallel to the longitudinal axis of the divider plate;*

*wherein the apparatus contains no component which, in use, attaches directly to the second face of the divider plate and which can extend beyond a lower edge of the divider plate into the gap between the divider plate and the subbase, and*

*wherein the elongate extension is attached to the divider plate via a loose fit such that, in use, it can automatically drop down to the subbase.*

## **Claim construction**

13. Before considering the request further I need to construe claim 1 of the Patent, that is to say I must interpret it in the light of the description and drawings as instructed by Section 125(1). In doing so I must interpret the claims in context through the eyes of the person skilled in the art. Ultimately the question is what the person skilled in the art would have understood the patentee to be using the language of the claims to mean. This approach has been confirmed in the recent decisions of the High Court in *Mylan v Yeda*<sup>2</sup> and the Court of Appeal in *Actavis v ICOS*<sup>3</sup>.

---

<sup>2</sup> Generics UK Ltd (t/a Mylan) v Yeda Research & Development Co. Ltd & Anr [2017] EWHC 2629(Pat)

<sup>3</sup> Actavis Group & Ors v ICOS Corp & Eli Lilly & Co. [2017] EWCA Civ 1671

14. The skilled person is considered to be an engineer specialising in concrete floor construction, and in particular joints for concrete floors.
15. Firstly, the claim is directed to apparatus for a particular purpose/process. Such claims are construed as apparatus *suitable for* the specified purpose/process and are anticipated by such suitable apparatus regardless of whether or not there is any disclosure of the apparatus being used in the relevant way.
16. The apparatus is “*for forming an edge of a concrete floor*”. It would typically be necessary to connect the apparatus of the invention to similar joints and/or to further elements in order to complete the necessary formwork before the concrete is poured and the edge is formed. The claim clearly should not be construed as requiring a complete formwork. Page 15, line 6 of the patent states, “*The apparatus will form at least part of an edge of a space for casting concrete*” and this language is also mirrored in the method of claims 22 and 24. I also note that page 11, lines 16 to 18 specify that “*The apparatus according to the first aspect of the invention can be used to form, for example, prefabricated four-way intersections, three-way “T” intersections, corner units and loading dock corners.*” None of these elements would be used to form a complete edge. Accordingly I consider that this part of the claim should be construed as apparatus that is *suitable for* forming an edge or *part of* an edge of a concrete floor.
17. Similarly, the claim requires a divider plate “*for bounding a side of the slab panel*”. Whilst this could suggest that the divider plate bounds the entire side of a slab, for the same reasons as above, I consider that this phrase should be construed as “*for bounding at least part of a side of the slab panel*”.
18. The final part of the claim requires that “*the elongate extension is attached to the divider plate via a loose fit such that, in use, it can automatically drop down to the subbase*”. I consider that this phrase needs to be construed purposively to reflect that the extension is provided to prevent concrete seeping between the joint and the subbase. I.e. the extension eliminates the gap between the joint and the subbase. Furthermore, this happens *automatically*. There is no elucidation of this term in the description. In certain circumstances automatic may imply some form of control system but that is clearly not relevant in this instance. I consider the skilled person would understand that it is simply intended to reflect that the extension moves without any manual intervention, and it should be construed accordingly. This part of the claim therefore requires that the elongate extension is attached loosely so that as it is being installed the extension plate drops to fill the gap between the joint and the subbase, and this is done without any manual intervention.
19. The requester has observed that the term “*divider plate*” may lack clarity, at least when the plate is not used to divide two slabs of concrete. I consider the divider plate simply acts to delineate and divide two areas or spaces from one another and there is no lack of clarity.
20. Having construed the claim I now need to consider whether or not it is anticipated by or is obvious in view of the relied on prior art.

### **Permaban adapter plate**

21. In relation to novelty and inventive step I shall consider first the Permaban adapter plate.

The requester has provided a number of instruction leaflets<sup>4</sup> dated 2010 that show photographs of the adapter plate along with some brief details. A witness statement<sup>5</sup> was also provided corroborating the dates of the leaflets.

22. The Permaban adapter plate is provided for connecting together prior art joints having differing specifications when constructing formwork. The prior art joints, as with the joint illustrated in the patent, are intended to be joined end to end by means of a half-lap splice joint in the top rail connected by bolts through holes in the half-laps. In specific circumstances where it is necessary to connect together two joints having differing half-lap dimensions and/or different dimension holes, this adapter is provided, each end having different lap and/or hole dimensions so that it can fit between the different specification joints.
23. The figure below shows *front* and *rear* views of an adapter plate taken from one of the instruction leaflets provided. As can be seen the adapter plates are adjustable in height, ostensibly so that they can be used with different height joints. The instructions provided specify “*this instruction shows the adapter plate which can be used on both 200mm and 300mm [sic] [recte 330mm] deep joint.*” The figures below show an unextended form “*to suit 200mm deep joint*” and an extended form “*to suit 330mm deep joint*”. Wing nuts attached to the extension pass through slots in the divider plate. The wing nuts can be slackened off and the extension plate moved between the two extremes for use with the different height joints.

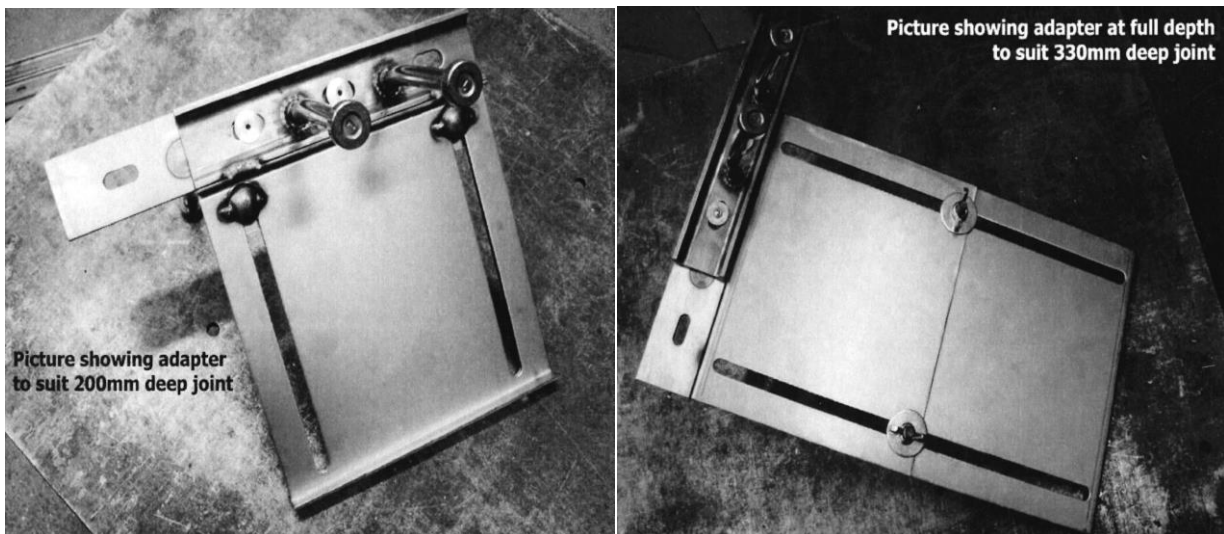

Figure 2 - front unextended view and rear extended view of Permaban adapter plate

24. The proprietor has argued that neither the instruction leaflets provided nor the adapter plate itself was ever made publically available.
25. Further evidence was provided by the requester as part of their observations in reply. I cannot however take account of such evidence as in my view it goes beyond *observations in reply* allowed for by the opinions process. In particular, there is no opportunity for the proprietor to challenge it.
26. Nevertheless, I consider that the evidence provided in the request proves on the balance of probabilities that the instruction leaflet and the adapter plates were provided to a

<sup>4</sup> Appendix 5 of the request.

<sup>5</sup> Appendix 7 of the request.

customer as part of the Continental Tyres Project during the first half of 2010, and there were no confidentiality restrictions. The evidence includes the dates on the instruction leaflets themselves, the notice on the instruction leaflet regarding the different specification shuttering that was provided in the three shipping containers for the Continental Tyres Project, and the information as to dates and the lack of confidentiality provided in the witness statement accompanying the request. The adapter plates and instruction leaflet were therefore publicly available before the filing date of the invention.

27. In determining whether or not claim 1 is anticipated I must consider whether the adapter plate possesses all the features of the claim. The adapter plate is considered to have all the features required except that it does not explicitly provide for:
- i) an elongate extension, securable along the first face of the divider plate, for sliding extension to an extended position in which the extension bridges a gap between the divider plate and the subbase in use
  - ii) wherein the elongate extension is attached to the divider plate via a loose fit such that, in use, it can automatically drop down to the subbase.
28. Firstly, I need to consider whether the adapter plate has an elongate extension. The patent description (page 4, line 9) makes clear that elongate means that the extension has an elongate shape. In my view the adapter plate extension does not have an elongate shape. The extension appears to be reasonably square or at least not so far from square that it is identifiable as elongate. Additionally neither the extension nor the divider plate has a readily identifiable longitudinal axis such that it is not possible to say whether their longitudinal axes are parallel as further required by claim 1.
29. Although I consider that the extension is not elongate, I will nevertheless go on to consider whether or not the adapter plate has feature (ii) identified above.
30. The requester argues that the wing nuts can be slackened to provide a loose fit and so configured the extension will drop to the subbase and bridge the gap between the divider plate and the subbase.
31. However, this argument overlooks the specified purpose of the extension which is to allow the adapter to be used with both 200 mm and 330mm joints. In the absence of any evidence to the contrary, it seems to me that the wing nuts will be fastened at either extreme, depending on the intended use, before the adapter plates are connected to the joints to form the formwork. The wing nuts will not subsequently be loosened. The intention is that the adapter plate will match the fixed height of the shuttering it is connected to.
32. Based on my interpretation of the intended method of use of the adapter plates, I do not consider that they comprise an extension which would fall to the subbase without manual intervention as I have construed this part of claim 1. As I see it, the adapter plates will be installed with the wing nuts tightened so that the extension is fixed during installation. If the wing nuts were subsequently loosened that would be manual intervention such that it does not fall within the scope of the term automatically as I have construed it. In other words, the extension plate does not, in use, automatically fall to the subbase.
33. The Permaban adapter plate is therefore considered to lack an elongate extension and the extension it does have does not automatically fall to the subbase such that it does not

comprise all the features of claim 1, and claim 1 is accordingly not anticipated by it.

34. Having found that claim 1 is not anticipated by the Permaban adapter plate I will go on to assess whether or not it lacks an inventive step.
35. The requester has seemingly foreshadowed the fact that the adapter plates do not comprise an elongate extension and has suggested that the arrangement could equally apply to a long length of joint and that claim 1 would accordingly be obvious.
36. Whilst it may arguably be obvious to provide a longer (or even shorter) adapter plate such that it may be described as having an elongate extension, I nevertheless do not consider it obvious to use the adapter plate in such a way that the extension will automatically fall to the subbase. As I have interpreted it, the adapter plate is extendable so that it matches the height of the joints it is used with. I do not see any motivation for forming a loose connection which would allow for the extension to automatically fall to the subbase. The adapter plates have been designed for a specific narrow purpose as a solution to a particular problem, and they are intended to be adjustable to match the two different fixed height joints they may be attached to and are simply for connecting together such fixed height joints. Whilst it may seem obvious with hindsight, I cannot see any reason at the date of filing why it would be obvious to the skilled person to install the adapter plate whilst the wing nuts were loosened. There seem to be good reasons why the wing nuts would be tightened before installation such as ease of handling and improved rigidity, and that is what the skilled person would understand and do.
37. On the basis that it is not obvious to modify the use of the Permaban adapter plate so that the extension falls automatically to the subbase, I consider claim 1 to be both novel and inventive in relation to it.

### **Permaban 4-Way Mini**

38. The Permaban 4-Way Mini is a 4-way intersection to be used at the intersection of four adjacent concrete slabs. It allows for a rigid connection at the point where four standard prior art joints meet to form the corners of the formwork and ultimately the corners of the slabs.
39. The principle evidence provided comprises a marketing leaflet<sup>6</sup> taken from a website<sup>7</sup> which pre-dates the filing date of the patent. However, the applicable part of the leaflet is a small picture labelled 4-Way Intersection (reproduced below), comprising only approximately 5% of the overall leaflet and the relevant details are not discernible.

---

<sup>6</sup> Appendix 5 of the request.

<sup>7</sup>[http://web.archive.org/web/20111005082218/http://www.permaban.com:80/\\_assets/documents/brochures/alphajoint/006%20-%20alphajoint%20sales%20brochure.pdf](http://web.archive.org/web/20111005082218/http://www.permaban.com:80/_assets/documents/brochures/alphajoint/006%20-%20alphajoint%20sales%20brochure.pdf)

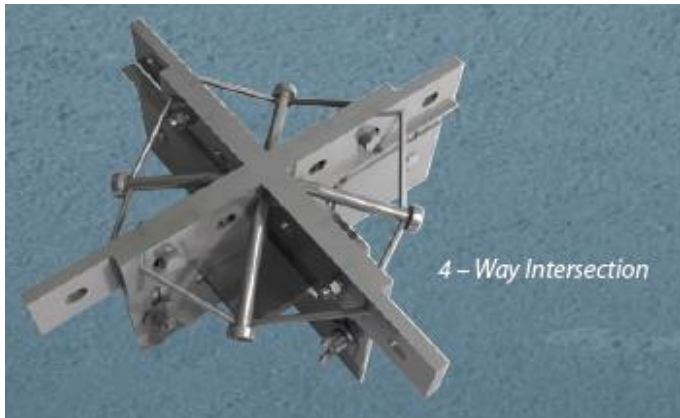

Figure 3 - Permaban 4-way mini unit

40. This evidence is supplemented by a confidential (at creation and at the filing date) technical / engineering drawing of a 4-Way intersection<sup>8</sup> (reproduced below) showing a plan and side view. This drawing is titled 4-Way Mini and dated 19 April 2010. It is provided to show details of the photograph and is not intended as prior art itself.

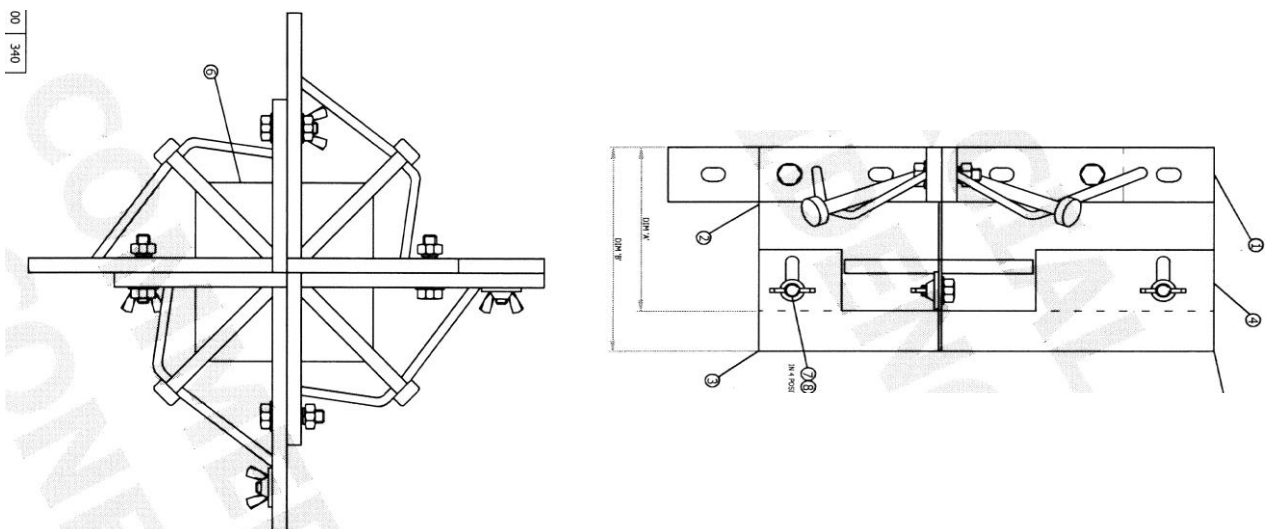

Figure 4 – Technical drawing of Permaban 4-way mini unit - plan and side views

41. The requester has also provided a couple of paragraphs describing the 4-Way Mini. In particular it is described as having upper and lower divider plates as follows:

*“Beneath the crossed radial strip joints extend upper divider plates. These correspond to the divider plates of the Patent. Beneath the upper divider plates are lower divider plates. These have slots allowing them to move up and down, Carriage bolts, which incidentally have heads similarly shaped to the rivets described in the Patent, hold the lower divider plates in position with the aid of wing nuts.”*

42. In their observations the proprietor objected that no details could be discerned from the website photograph and the manufacturing drawing could not be used to supplement the disclosure of the photograph as it was not publically available at the filing date of the

<sup>8</sup> Appendix 4 of the request.



patent. The photograph could only be considered in the light of prior art available at the filing date and the skilled person's common general knowledge at that date.

43. The requester has attempted to rectify this in their observations in reply by way of details of sales of the 4-Way Mini which occurred prior to the filing date and an accompanying witness statement. As with the adapter plate, I do not believe I can take account of such further evidence, it not being strictly observations in reply. This is evidence that the proprietor has not had a chance to comment on and that could have been submitted with the request.
44. I note the statement made in the request that *"For the avoidance of doubt, the Alpha joint 4010 4-Way Unit in Appendix 6 is not the 4-Way Mini unit of Appendix 4. The latter is a development of the former"*. Appendix 6 of the request is the Permaban UK Price List 2010. Page 7 refers to the Alphajoint 4010 4-Way Unit including a 4-Way Mini. The 4-way product illustrated in the price list is not the same as that in the screenshot or technical drawing and has no adjustable lower divider plate.
45. It does not therefore seem entirely clear what product was made available to customers and when (and the observations in reply evidence does not on the face of it satisfactorily resolve this). I do not therefore consider that the requester has proved on the balance of probabilities that the Permaban 4-way Mini had been made available to the public at the filing date of the invention. I agree with the proprietor that the photograph provides insufficient detail for the skilled person to be able to satisfactorily interpret it, and the technical drawing was confidential at the filing date.
46. Nevertheless, in case the requester is capable of remedying the deficiencies in their evidence and/or in order to provide some guidance to the parties, I will go on to consider whether or not the 4-way Mini unit identified in the technical drawing has all the features necessary to fall within the scope of claim 1.
47. Firstly, the patent specifies that the apparatus according to the first aspect of the invention can be used to form prefabricated four-way intersections. In view of this statement I consider that four-way intersections, such as the 4-Way Mini, would be understood by the skilled person to comprise apparatus for forming at least part of an edge of a concrete floor slab as I have construed the initial part of claim 1. Similarly, it has a divider plate, in the form of the upper divider plate, for bounding at least part of a side of the slab panel.
48. Secondly, and in contrast to the adapter plate, I am satisfied that the 4-Way Mini has an elongate extension in the form of the lower divider plate. Even if the lower divider of just one quadrant of the 4-Way Mini is interpreted as being the extension plate of the claims, the drawing nevertheless shows a lower divider plate on one side which appears about twice as long as it is high such that it is considered elongate. Additionally the longitudinal axis of the extension is parallel to the longitudinal axis of the (upper) divider plate.
49. Having established that the 4-Way Mini has an elongate extension, I must further consider whether the elongate extension is *"attached to the divider plate via a loose fit such that, in use, it can automatically drop down to the subbase"*, as I have construed this phrase.
50. As with the adapter plate, the requester's principle argument relates to the loose fit feature, and they argue that it is the nature of wingnuts that they are loosened and that in

use they would be loosened to allow the lower divider plate to fall to the subbase.

51. The requester has not provided any information in their request to indicate why the 4-Way Mini was designed with an adjustable lower divider. I do not believe that the lower divider was provided to effectively close the gap between the subbase and the lower edge of the divider to prevent concrete leakage. Simply closing the gap at the corners and not in between would seem ineffectual. In any event the requester has not suggested that was the purpose of the lower divider. I consider that the adjustable lower divider has been provided for the same reason that the Permaban adapter plate is height adjustable and that is so that the height of the 4-Way Mini can be adjusted to match the height of the joints to which it is attached. Accordingly, as with the adapter plate, the wing nuts would be loosened before the unit was installed to match the height of the unit to the height of the elongate joints. The wing nuts would subsequently be tightened to maintain the unit at that height. At some point later it would be installed but the wing nuts would not be subsequently loosened and the lower divider plate would not fall to the subbase level.
52. Given that the 4-Way Mini is adjusted in the same way as the adapter plate, i.e. before installation, it follows that the extension does not in use automatically fall to the subbase in the same way and for the same reasons I have given above in relation to the adapter plate. It therefore does not anticipate claim 1.
53. Similarly, for the same reasons as given above in relation to the adapter plate, I do not consider it obvious to modify the method of use of the 4-Way Mini. The requester has suggested it is obvious *“to provide not just an adjustable lower divider but also one that is able to fall to the sub-base when released”*. As above, whilst it seems obvious with hindsight, I cannot see any reason why it would be obvious to the skilled person to install the 4-Way Mini whilst the wing nuts were loosened.
54. I therefore consider that claim 1 is novel and inventive in relation to the Permaban 4-Way Mini unit.

## **Dependant claims**

55. The remaining claims, 2 to 25, are all dependant claims. As I have found claim 1 to be novel and inventive I do not need to consider these claims in any detail. They are also novel and inventive based on their dependency.

## **Sufficiency**

56. The requester has identified that the patent refers to the use of a rivet (page 14, line 2) for the loose connection and has suggested that there is no way of creating a loose fit with a rivet. The requester goes on to argue that, absent any instruction in the patent about how to form a loose connection with a rivet, the patent lacks sufficient teaching to be able to be put into practice. Whilst it may be an atypical use of a rivet I consider that the skilled person would be able to effect a loosely riveted connection in some manner and the proprietor has provided suitable evidence pre-dating the filing date of the patent to show that it was known to make loose rivet connections (by inserting a removable material between the items being riveted). In any event the patent refers to other ways of creating the loose fit (page 7, line 21) such as nuts and bolts, etc.

57. I therefore consider that the invention is disclosed clearly and completely enough for it to be performed by a person skilled in the art.

### **Added matter**

58. The requester argues that matter has been added in part as a consequence of deletion of subject matter from the description.

59. The test for added matter set out by Aldous J in *Bonzel and Schneider v Intervention Ltd*<sup>9</sup> is as follows:

- 1) *to ascertain through the eyes of the skilled addressee what is disclosed both explicitly and implicitly in the application;*
- 2) *to do the same in respect of the patent as granted;*
- 3) *to compare the two disclosures and decide whether any subject matter relevant to the invention has been added whether by deletion or addition. The comparison is strict in the sense that subject matter will be added unless such matter is clearly and unambiguously disclosed in the application either explicitly or implicitly.*

60. This was summarised by Jacob J in *Richardson-Vicks Inc.'s Patent*<sup>10</sup> as:

*“the test of added matter is whether a skilled man would, upon looking at the amended specification, learn anything about the invention which he could not learn from the unamended specification.”*

61. The particular amendment complained of is the final characterising clause added to claim 1 which served to distinguish the invention from the prior art referred to during examination. The final clause reads:

*“wherein the elongate extension is attached to the divider plate via a loose fit such that, in use, it can automatically drop down to the subbase”.*

62. The requester recognises that support for this passage is found in the patent as granted but maintains nevertheless that deletion of parts of the text means that the amendment to claim 1 omits features which were originally an essential part of the invention now claimed.

63. In the first instance the requester notes the deletion of the following part of the description where the deleted text is shown in bold (page 14, lines 3 to 6):

*In the embodiment shown in Figures 1 to 9, the position of the extension 2 relative to the divider plate 1 can be adjusted in a continuous manner, and the extension 2 is attached to the divider plate 1 via a loose fit. The extension 2 **has a stowed position, where the extension 2 and the plate 1 are held together by friction means (not shown), but if the extension 2 is moved down relative to the divider plate 1 by a predetermined distance (i.e. towards a more extended form), the extension 2 can drop down to the subbase under***

---

<sup>9</sup> *Bonzel and Schneider (Europe) AG v Intervention Ltd* [1991] RPC 553

<sup>10</sup> *Richardson-Vicks Inc.'s Patent* [1995] RPC 568

*gravity while remaining attached to the divider plate.*

64. In its original form this paragraph teaches an embodiment in which the extension has both a stowed position, when it is held to the divider plate by friction means such that it is not able to move under gravity, and a loosely connected position in which it drops to the subbase under gravity. Only the latter feature is required by claim 1 as granted. The requester argues that because the claim has been amended to require only the latter feature, and there is no suggestion in the original description that the former feature is optional in this arrangement, the patent adds matter.
65. The requester also points to the following deletion made during amendment, the deletion being shown in bold (page 5, lines 12 to 16):

*In addition to this, the apparatus according to the first aspect of the invention can be easier to operate than existing apparatus in this field. After the divider plate has been suspended at the desired FFL using suspension means such as, for example, a jack, **the position of the extension relative to the divider plate can, for example, be adjusted simply by tapping the extension down to the subbase level, or if the extension is attached to the divider plate via a loose fit it can automatically drop down to the subbase level.***

66. The requester argues that there is some ambiguity in this passage in its original form but the skilled reader, when considering the document as a whole, would understand that it was referring to the extension either being tapped down all the way to the subbase level or being tapped down from the stowed position to the loose fit position at which point it would fall automatically to the subbase level.
67. Finally, the requester points to original claim 9:

*9. The apparatus of claim 8, wherein the divider plate and the extension are arranged to cooperate such that, when the extension is in the stowed position, the extension and the divider plate are held together by friction means to resist extending movement, but if the extension is extended by a predetermined distance, the extension can, in use, drop down to the subbase under gravity while remaining attached to the divider plate.*

68. This claim requires both the features identified above, namely that the extension is held in the stowed position by friction means and that it is movable into a loose fit position in which it drops down under gravity. The requester observes that there is no suggestion that these features are separable, and that accordingly amended claim 1 which requires only the loose fit adds matter.
69. The question that needs to be considered is whether claim 1 adds matter because it requires only a loose fit and does not require a loose fit in combination with a stowed friction fit position.
70. The proprietor maintains that claim 1 does not add matter because the clause added to claim 1 during amendment was taken directly from the passage on page 5, lines 12 to 16, "*wherein the extension is attached to the divider plate via a loose fit it can automatically drop down to the subbase level*". The proprietor amended to restrict the invention to one of the two variants disclosed in this paragraph and deleted the text directed to the other variant.

71. In the observations in reply the requester focusses on the meaning of the word “can”, and suggests that in order to determine the conditions under which the extension *can* drop, the skilled person would identify that it was after the extension had been moved by a pre-determined distance as specified in the description on page 14, lines 3 to 9.
72. I disagree with the requester’s argument. Firstly, this seems to be meticulous verbal analysis of the type that is to be shunned. Second, it seems that in making the amendment to claim 1 the proprietor identified the condition under which the extension can drop to the subbase, and that is *in use*. Furthermore, I consider that this would have been apparent to the skilled person. It is only as the joint is being installed in position that the extension drops to the subbase. The amendment made to claim 1 was supported by the passage identified by the proprietor and there is no ambiguity in this passage. It originally disclosed either an extension which had to be hammered to the subbase or an extension which was a loose fit and could fall under gravity.
73. I also note the paragraph following the above identified passage on page 5 which describes the advantages of the invention as follows:
- “Therefore the apparatus can enhance the ease with which concrete floor slab panels can be produced, can enhance the performance characteristics of the resulting concrete floor slabs, and can eliminate the need to trim off concrete spillage, which can save time and reduce waste management costs on site.”*
74. This may be compared with the passage on page 6, line 18 which follows the initial disclosure of stowed and extended positions and states *“This stowed form can make the apparatus more convenient to store, transport and handle”*.
75. It seems to me the skilled person would understand that only the loose fit is required to achieve the benefits identified on page 5, and that the benefits on page 6 are additional and relate to the provision of a stowed position. In other words, the stowed position is not required to realise the benefits of the invention which relate to preventing seepage of concrete.
76. There is nothing in the invention now claimed in claim 1 which was not already explicitly disclosed in the application as filed. The application as filed refers explicitly and in isolation to an extension attached to the divider plate via a loose fit. Accordingly there is nothing to be learned about the invention as claimed which could not be learned from the application as filed and there is therefore no added matter.

## **Opinion**

77. On the basis of the evidence considered and the arguments put forward, I am of the opinion that the invention of GB 2507071 B is novel and inventive in relation to both the Permaban adapter plate and the Permaban 4-Way Mini unit.
78. It is also my opinion that, based on the arguments made, GB 2507071 B does not comprise added matter and is disclosed clearly and completely enough for it to be performed by a person skilled in the art.

79. I offer no opinion in relation to the validity of the patent based on DE 20 2009 000 007 U1 (HAMMES).

Matthew Jefferson  
Examiner

---

**NOTE**

*This opinion is not based on the outcome of fully litigated proceedings. Rather, it is based on whatever material the persons requesting the opinion and filing observations have chosen to put before the Office.*