



Ministry
of Defence



DE&S Secretariat (Land Equipment)

DESSEC-PolSecLE-JSC-WPNS@mod.uk

Defence Equipment & Support
Maple 0a # 2043
MOD Abbey Wood
Bristol BS34 8JH



[Redacted]

Via:

request-422421-f81b51ec@whatdotheyknow.com

20th September 2017 Our Ref: FOI2017/08516

Dear [Redacted],

Thank you for your email of 31st August 2017 requesting the following information:

I'm looking for the manual kit that includes the installation of the anti-riot kit (meshed screens etc) on the pulse battlefield ambulance

*The official name on the plate inside the car is:
"AMB battlefield HS stretcher"
"4 x 4 land rover 2.5 LTR TURBO DSL"
It was registered as "KY 50 AA"*

I am treating your correspondence as a request for information under the Freedom of Information Act 2000 (FOIA).

A search for the information has now been completed within the Ministry of Defence, and I can confirm that information in scope of your request is held and is attached to this letter.

If you have any queries regarding the content of this letter, please contact this office in the first instance.

If you wish to complain about the handling of your request, or the content of this response, you can request an independent internal review by contacting the Information Rights Compliance team, Ground Floor, MOD Main Building, Whitehall, SW1A 2HB (e-mail CIO-FOI-IR@mod.uk). Please note that any request for an internal review should be made within 40 working days of the date of this response.

If you remain dissatisfied following an internal review, you may raise your complaint directly to the Information Commissioner under the provisions of Section 50 of the Freedom of Information Act. Please note that the Information Commissioner will not normally investigate your case until the MOD internal review process has been completed. The Information Commissioner can be contacted at: Information Commissioner's Office, Wycliffe House, Water Lane, Wilmslow, Cheshire, SK9 5AF. Further details of the role and powers of the Information Commissioner can be found on the Commissioner's website at <https://ico.org.uk/>.

Yours sincerely,

DES SEC Pol Sec Land Equipment

**TRUCK UTILITY LIGHT (TUL) HS, TRUCK UTILITY MEDIUM (TUM) HS
AND TUM BATTLEFIELD AMBULANCE HS**

MODIFICATION INSTRUCTION NO. 18

CONTENTS

Sponsor: CSV(Sp) IPT
Project number: CSV031
File ref:
Publication agency: Defence Logistics Organisation

AMENDMENT RECORD

Amdt No.	Incorporated By (Signature)	Date	Amdt No.	Incorporated By (Signature)	Date
1			4		
2			5		
3			6		

SUBJECT: Fitting of front windscreen and side and rear window protection screens
(Approval No LSTP 12-6675)

INTRODUCTION

1 This Modification Instruction details the fitting of the front windscreen and side and rear window protection screens (Hard Top) for short term operational requirements.

1.1 Limitations on use of equipment. Nil.

APPLICABILITY

2 All variants of Truck Utility Light (TUL) High Specification (HS) and Truck Utility Medium (TUM) HS vehicles but not including Battle Field Ambulance on the authority of Equipment Manager at Defence Logistics Organisation (DLO).

2.1 Fitted to subject equipment held by user units.

REASON FOR MODIFICATION

3 Code 6 – Short term operational requirements.

PRIORITY

4 ARMY: Routine.

5 RAF: Class 3.

ESTIMATED TIME REQUIRED

6 Embodiment: 3.0 man-hours.

Modification implementation plan

- 7 This Modification Instruction is to be implemented by:
- 7.1 ARMY - Units authorised to carry out Levels 2, 3 and 4 maintenance.
 - 7.2 RAF - Depot units when required.
- 8 Associated Modification Instructions. Nil.
- 9 Modification plate strike action. Nil.

Action required by

- 10 The following action is to be carried out:
- 10.1 Units and establishments holding equipment:
 - 10.1.1 Examine vehicle documents to see if this Modification Instruction is applicable.
 - 10.1.2 Examine the Modification record plate to see if the Modification is embodied and where necessary Units with Level 2 Royal Electrical and Mechanical Engineers (REME) Support demand the stores required.
 - 10.1.3 ARMY - On receipt of stores, request REME to modify equipment.
 - 10.1.4 ARMY - Record the modification, Subject Army Equipment Support Publication (AESP) number and Army Modification Code in equipment documents.
 - 10.1.5 RAF - Record modification details on Army Form General (AF G) 1084A and Form 4870. Units operating Station Transport Management Aid (STAMA) are also to record modification details on ADP Mechanical Transport Maintenance Section (MTMS) job Certification Sheet and to follow the procedures laid down in Air Publication (AP) 100C-08A.
 - 10.2 Army units authorized to carry out Levels 2, 3 and 4 maintenance and RAF units:
 - 10.2.1 ARMY - When requested by users or during overhaul of equipment on charge without REME Level 2 Support, obtain the items listed in Para 11 and carry out this modification.
 - 10.2.2 Record completion details of modification against appropriate entry in equipment documents.
 - 10.2.3 Complete AF G1084A when reporting completion of the modification to FORWARD (RAF) using the following code:
 - 10.2.3.1 RAF: MODIFICATION CODE: AFN 171.
- NOTE
- RAF units operating STAMA are also to complete ADP MTMS Job Certification Sheet and to follow the procedures laid down in AP 100C-08A.
- 10.3 All recipients of this instruction. Add particulars to AESP 2320-D-128-811 Modification Instruction Index.

Stores, tools and equipment

11 The following set is to be demanded quoting this Modification Instruction authority:

11.1 Stores to be demanded:

Item No.	DMC	NSN/Part No.	Designation	Qty per eqpt
	7RU	2510-99-335-2895	Front screen/front door windows protection kit Comprising:	1
1			Front screen frame assy	(1)
2			Front door screen frame assy (RH)	(1)
3			Front door screen frame assy (LH)	(1)
4			Front screen support strut (RH)	(1)
5			Front screen support strut (LH)	(1)
6			M8x80 Hex bolts	(2)
7			M8x40 Hex set screw	(2)
8			M8 Nyloc nut	(4)
9			M8 Flat washer	(8)
10			Shaft locking pin	(2)
11			Rubber buffer	(2)
12			M6x20 set screw	(4)
13			M6 flat washer	(8)
14			M6 spring washer	(4)
15			Special retaining nut	(4)
16			M6 Rivnut	(4)
17			M6x35 Hex set screw	(4)
	7RU	2510-99-212-5216	Rear door window protection kit (Hard Top only) Comprising:	1
18			Screen assy	(1)
19			M8x75 Hex bolt	(4)
20			M8 flat washer	(4)
21			M8 spring washer	(4)
22			M8 rivnut	(4)

Sequence of operations

NOTE

The item numbers in Para 11 are used as references throughout this Modification Instruction.

12 Refer to Fig 1 and Fig 2 to carry out this Modification Instruction as follows:

12.1 Front windscreen protection screen assembly.

NOTE

Vertical support struts are fitted to each side of the windscreen. To ensure correct alignment the struts should be fitted progressively and independent of the screen guard.

12.1.1 Remove the pivot pin of the RH windscreen hinge and discard.

NOTE

The pivot pin is stepped in diameter. Ensure it is driven out from the end of the smallest diameter (refer to Fig 1).

12.1.2 Drill through the hinge pivot hole to enlarge pivot hole to receive the M8 bolt.

12.1.3 Offer the RH support strut (Item 4) to the windscreen and secure at the lower position, using M8 bolt (Item 6) washers (Item 9) and nyloc nut (Item 8) through the windscreen hinge. Loosely tighten the nut and bolt.

NOTE

Locally supplied packing washers may have to be used between the hinge and support strut to ensure the correct alignment of the screen and struts.

12.1.4 Remove the 'A' post trim from inside of windscreen frame.

12.1.5 With RH support strut in position and located firmly against the windscreen surround, drill out two 7 mm dia holes in windscreen surround using upper bracket as guide.

12.1.6 Secure the upper bracket to the windscreen surround using M6 set screws (Item 12) washers (Item 13) spring washers (Item 14) and special retaining nuts (Item 15).

NOTE

The special retaining nuts (Item 15) are shaped to match the inner profile of the windscreen frame and must be inserted correctly.

12.1.7 Repeat steps 12.1.1 to 12.1.6 for the LH side of the windscreen.

12.1.8 Fit Rubber buffers (Items 11) into the tapped holes positioned in the top and bottom rails of the protection screen (innerface).

12.1.9 With assistance, position the front protection screen (Item 1) between the support struts and using M8 set screws (Item 7), washers (Item 9) and nyloc nuts (Item 8) secure to the support struts at the lower pivot points. Tighten the set screws enough to allow the protection screen to be raised and lowered.

12.1.10 Refit trim to inside of the windscreen frame.

12.1.11 Raise and lower the protection screen and ensure the screen does not foul the vertical support struts. Add the packing washers to adjust clearance if required. Tighten all fixings.

12.1.12 Raise the screen and ensure the rubber pad (Fig 2, Item 4) rests against the vertical strut. Mark the vertical strut through the screen guard bracket (9). Lower the screen and drill through the vertical strut using an 8 mm dia drill. Repeat for both LH and RH sides.

12.1.13 Secure the screen in a vertical position using the locking pins (Item 10) through the support struts of the protective screen.

12.2 Front door window protection screens.

12.2.1 Refer to Fig 3 and proceed as follows:

NOTE

The following procedure is typical for guards fitted to both the driver's and passenger door.

12.2.2 Remove the two door top side screen cover staples by drilling out the rivets and retain.

12.2.3 Position the window protection screen assembly (Item 2) over the top of the RH front door, lining it up centrally with the window. Mark the position of the two lower fixing points through the side screen frame onto the door.

12.2.4 Remove the protection screen and drill two 9 mm dia holes in the front door and insert two M6 rivnuts (Item 16).

12.2.5 Re-hang protection screen over door and secure to door using two M6 set screws (Item 17) through the lower fixing points.

12.2.6 Repeat steps 12.2.2 to 12.2.4 for the LH side door.

12.3 Rear door window protection screen (Hard top only).

12.3.1 Position the rear window protection screen assembly (Item 18) squarely and centrally over the window in the rear door and mark the positions of the four holes through the screen onto the door.

12.3.2 Remove the screen and drill four 11 mm dia holes in the rear door and insert four M8 rivnuts (Item 22).

12.3.3 Secure the screen in position using four M8 bolts (Item 19), flat washers (Item 20) and spring washers (Item 21).

NOTES

(1) When the operational requirement for the protective screens no longer exists, the kit should be removed, parts made good, repackaged and returned to stores.

(2) Removal of the kit can be achieved by following the reverse of the above instruction. Refit the two side screen cover staples and fit new windscreen hinges.

(3) If new front windscreen hinges are not available the modified hinge can be secured with a suitable M8 nut and bolt until new parts are available.

TESTING AFTER EMBODIMENT

13 Nil.

EFFECT ON WEIGHT

14 No effect after removal (required for short term installation only).

PUBLICATION AMENDMENTS

15 Necessary amendments will be issued separately.

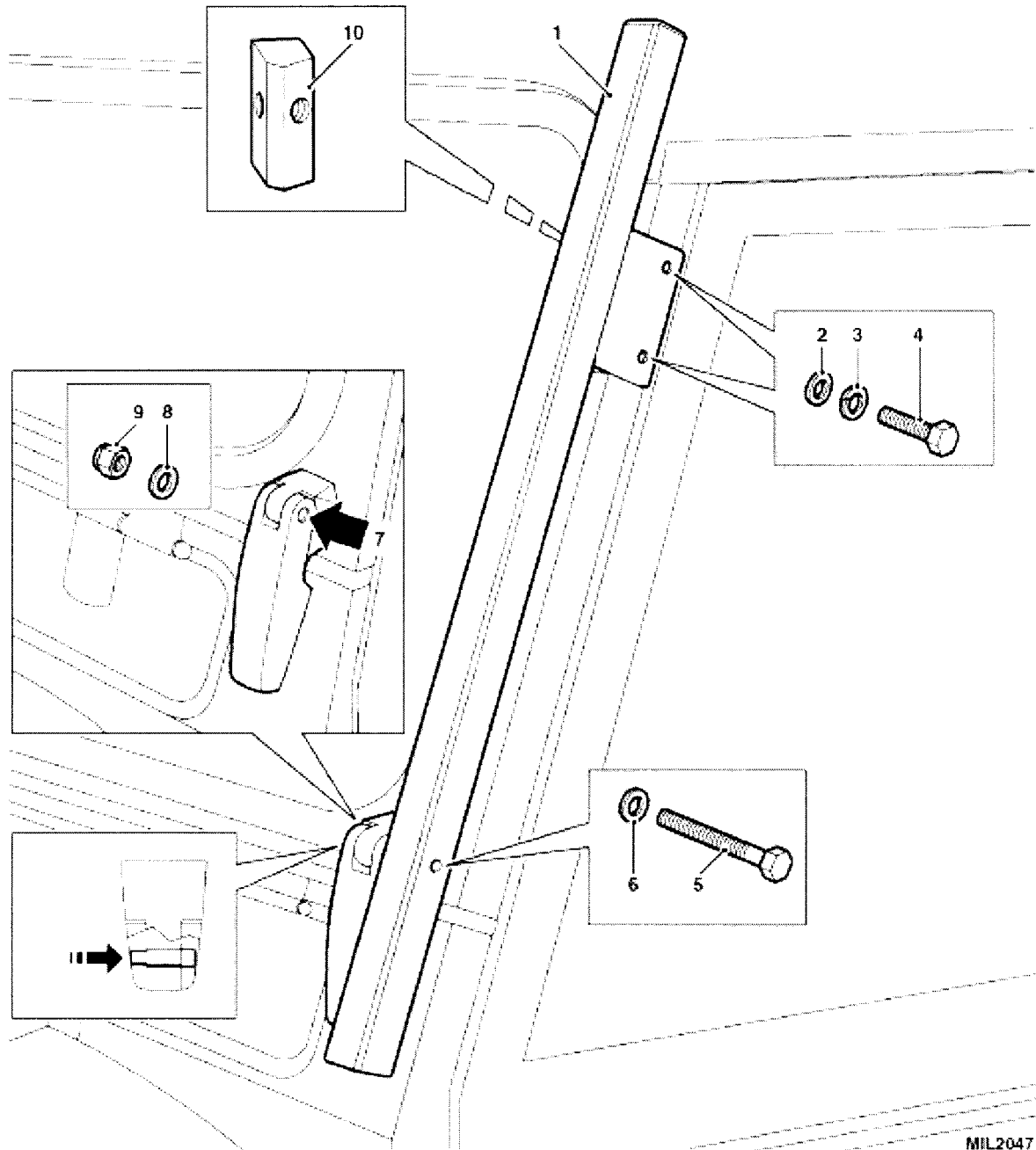

MIL2047

- | | |
|------------------|-------------------|
| 1 Vertical strut | 6 Washer |
| 2 Washer | 7 Packing washers |
| 3 Spring washer | 8 Washer |
| 4 M6 set screw | 9 Nylock nut |
| 5 M8 Bolt | 10 Retaining nut |

Fig 1 Fitting the front protection screen vertical support struts

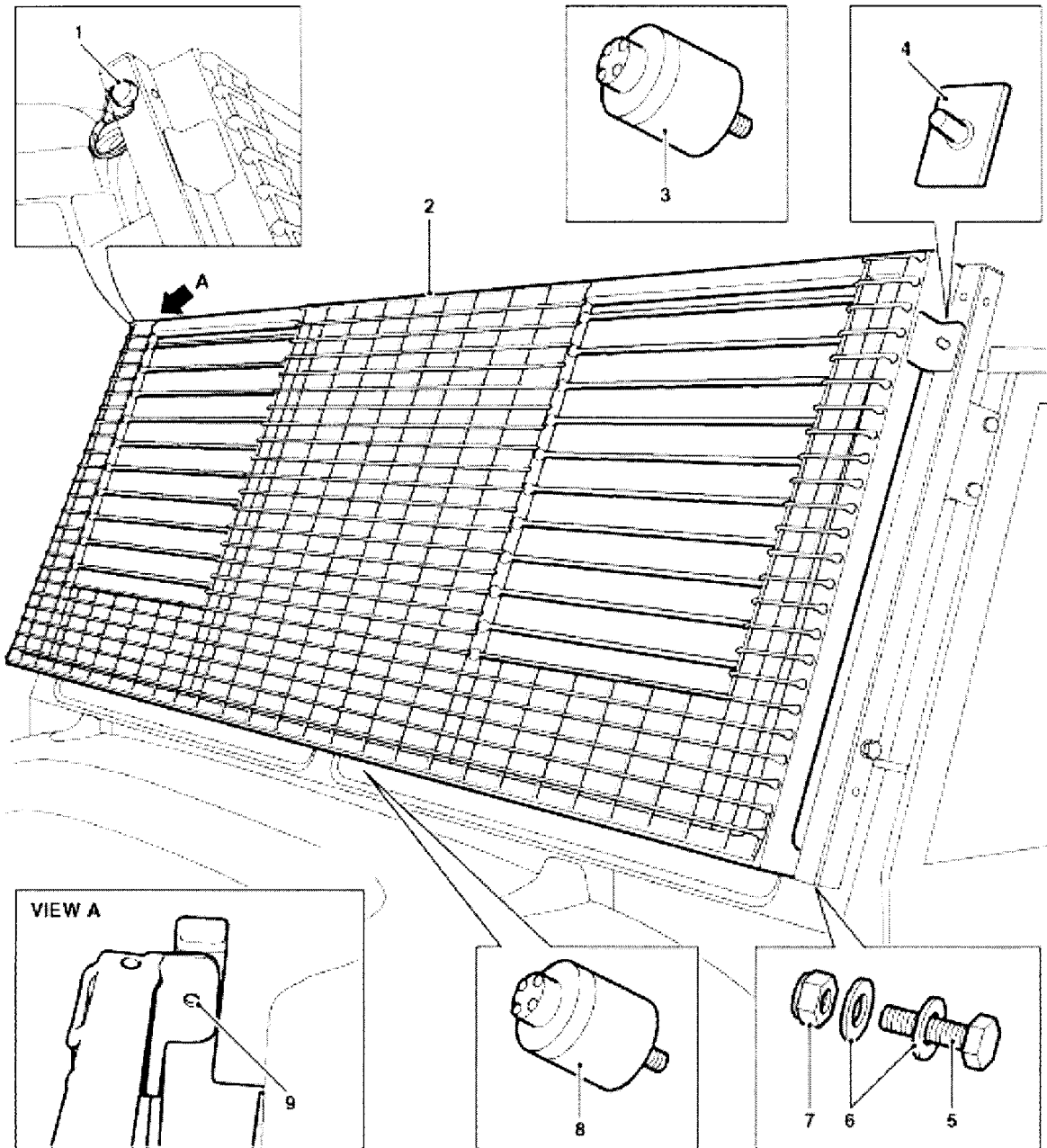

MIL2048

- | | |
|---------------------------|------------------|
| 1 Locking pin | 6 Washers |
| 2 Front protection screen | 7 Nylock nut |
| 3 Buffer | 8 Buffer |
| 4 Pad | 9 Screen bracket |
| 5 M8 pivot set screw | |

Fig 2 Fitting the front protection screen

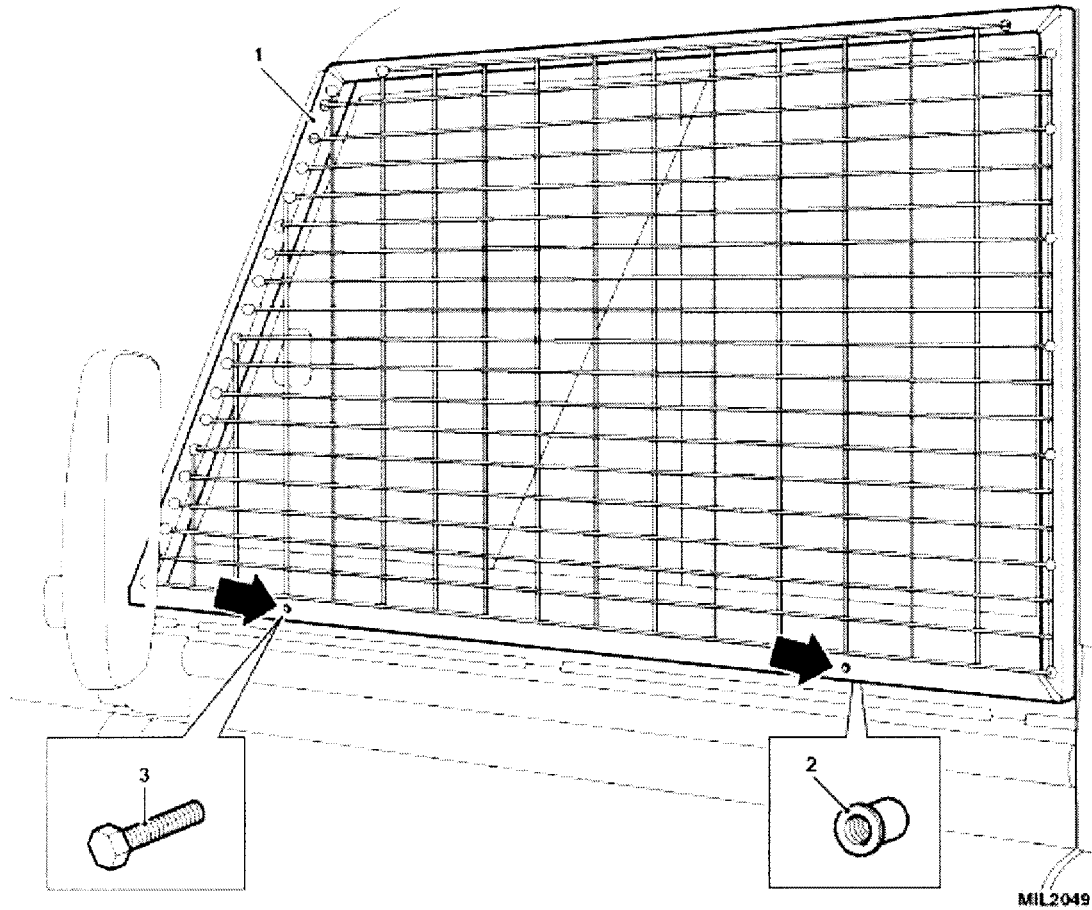

- 1 Front door protection screen
- 2 M6 rivnut
- 3 M6 set screw

Fig 3 Fitting the front door window protection screens