

**OPINION UNDER SECTION 74A**

Patent	EP 2086102 B1
Proprietor(s)	Fraunhofer-Gesellschaft zur Förderung der angewandten Forschung e.V.
Exclusive Licensee	
Requester	Jenner & Block London LLP
Observer(s)	JA Kemp
Date Opinion issued	21 December 2017

**The request**

1. Jenner & Block London LLP (“the requester”) has requested that the Comptroller issue an opinion as to whether patent EP 2086102 B1 (“the patent”) is valid having regard to the following matters:
  - a) whether claims 1 and 9 involve an inventive step over an MSc thesis entitled, “*The Design and Implementation of a Modified Single Phase Inverter Topology with Active Cancellation of Common Mode Voltage*”, by Mr Aakash V.K. Rao, submitted to the University of Wisconsin in Madison in 1998 (“RAO”);
  - b) whether claims 1 and 9 are novel over a PhD thesis entitled “*Active Common Mode Voltage Reduction in Voltage Source Inverters*” submitted by Alexander L. Julian to the University of Wisconsin in 1997 (“JULIAN”);
  - c) whether claim 1 is novel over US 5852558 A (“US ‘558”);
  - d) whether claim 9 of the patent contains added matter.
2. The request refers to an English translation of the German-language description of the patent. This translation is the English-language description of the Proprietor’s corresponding EP(DK) patent (publication no. DK/EP 2086102 T3). I have worked from this translation to arrive at my opinion.

**Observations and observations in reply**

3. Observations were received from JA Kemp (“the observer”). Subsequently, observations in reply were received from the requester.

## Opinion 02/17

- The request is the requester's second request for an opinion on the patent. The first request resulted in Opinion 02/17 ("the earlier opinion") being issued on 25 April 2017. Both the requester and the observer mention the earlier opinion in their submissions. It is relevant to note that the earlier opinion concluded, amongst other things, that claims 1 and 9 are novel over RAO. I also note that the Proprietor has requested a review of the earlier opinion and that the review proceedings are ongoing.

## The patent

- The patent is entitled "Inverter for converting an electric direct current into an alternating current or an alternating voltage". The patent was granted in respect of a divisional application divided from parent application EP 03009882.6 ("the parent application") which was filed on 15 May 2003 with a declared priority date of 15 May 2002. The patent was granted with effect from 22 September 2010 and remains in force.
- The patent relates to an inverter (or DC/AC converter) for transforming a direct current (DC) voltage to an alternating current (AC) voltage. Fig. 1 (reproduced below) shows a schematic circuit of an inverter according to the invention.

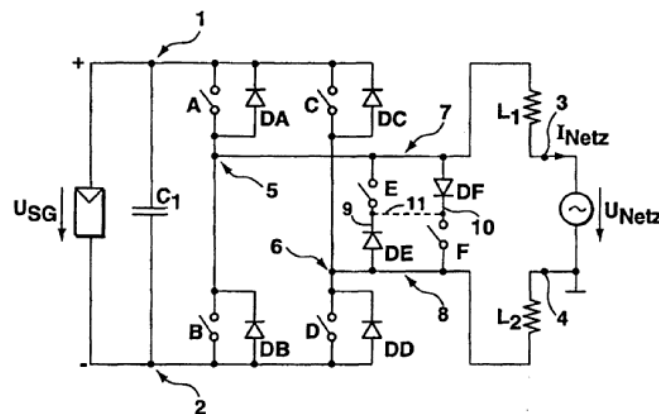
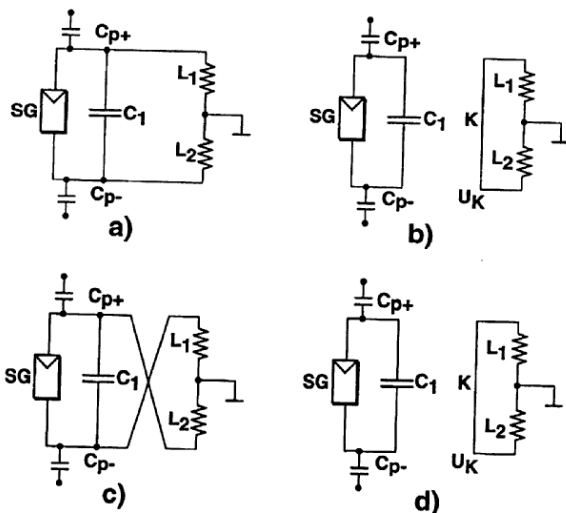

**Fig. 1**

- The inverter has two direct voltage terminals 1, 2 for connection to a direct voltage source  $U_{SG}$ , such as an external solar generator, and two alternating voltage terminals 3, 4 for connection to either a conventional 50Hz power network or, in the case of "island" operation, to an electrical load. The inverter includes a buffer capacitor  $C_1$  connected in parallel to a full bridge circuit having four switches A, B, C, D and rectifier (or "freewheeling") diodes DA, DB, DC and DD. The output of the bridge is provided between the two parallel branches of the bridge circuit at connection nodes 5, 6 by connection lines 7, 8. Connection lines 7, 8 are connected to alternating voltage terminals 3, 4 respectively via respective choke inductivities  $L_1$ ,  $L_2$ . Page 13, lines 25-30, states that the "inventive difference" over known topologies (such as those shown in Fig. 2 of the patent) is the provision of two additional electrical connection paths 9, 10 between the connection lines 7, 8. Additional

electrical connection paths 9, 10 each include a switch E, F and a diode DE, DF. In an alternative embodiment (page 19, lines 16-25) a single high-frequency switch may be provided in a single connection path between connections lines 7, 8.

8. The operation of the inverter relies upon operating switches A-F in a particular manner. Fig. 7 of the patent (reproduced below) shows an example of the “symmetrical clocking” of switches A, B, C, D where diagonally opposite switches of the bridge are opened and closed according to a high-frequency clock pattern (e.g. using pulse-width modulation). During a positive half-cycle of the alternating voltage at alternating voltage terminals 3, 4, switch units A, D are closed/opened while switches B, C remain in an open state. Correspondingly, switches B, C are modulated using the same clocking pattern (while A & D remain open) during the negative half-cycle. In contrast, switches E, F (provided in the additional connection paths 9, 10) are operated synchronously with the alternating frequency of the network voltage  $U_{NETZ}$  (e.g. at 50 Hz). Switch E is closed during most of the positive half of alternating voltage cycle whereas switch F is open. Correspondingly, switch F closes during most of the negative half of the cycle with switch E in the open position.



**Fig. 5**

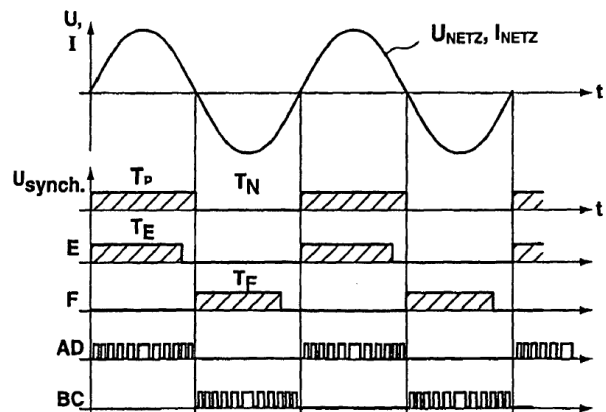

**Fig. 7**

9. The result of clocking the switches in this manner is illustrated in the equivalent circuit diagrams of Fig. 5 (reproduced above). During the positive half-cycle of the network voltage when switch E is closed, and at the times when switches A and D are also closed, current flows through switches A & D so that the positive terminal of the capacitor  $C_1$  is connected to choke  $L_1$  and the negative terminal of the capacitor is connected to choke  $L_2$  (see Fig. 5a). However, at the times when switches A, D are open (i.e. in one “freewheeling” phase), the coil current due to the choke inductivities  $L_1, L_2$  will flow through diode DE, creating a freewheeling path K, and does not flow back to buffer capacitor  $C_1$  (see Fig. 5b). In other words, assuming ideal conditions, there is no electrical connection between the solar generator and the network. Similarly, in the negative half-cycle when switch F is closed, and at the times when switches B and C are closed, current flows through switches B and C such that the positive terminal of the capacitor  $C_1$  is now connected to choke  $L_2$  and the negative terminal of the capacitor is connected to choke  $L_1$  (see Fig. 5c). However, when switches B, C are open (i.e. in another freewheeling phase) the coil

current flows through diode DF creating freewheeling path K (Fig. 5d) and, again, the solar generator and the network are electrically disconnected.

## The claims

10. Claims 1 and 9 are the only independent claims of the patent. They define an inverter and a method, respectively, as follows.

*1. An inverter for feeding the energy originating from a solar generator to a grounded network, the inverter comprising:*

*two solar generator terminals (1, 2);*

*an energy buffer (C1) for buffering the energy originating from the solar generator;*

*a bridge circuit which is connected in parallel to the energy buffer (C1) and comprises at least two parallel branches which each comprise two switch units (A, B; C, D) connected in series, in parallel to each of which a rectifier diode (DA, DB, DC, DD) is connected; and*

*at least two alternating voltage terminals (3, 4) each of which is individually connected, via a connection line (7,8) in which one respective choke inductivity (L1, L2) is provided, to one of the parallel branches of the bridge circuit between two switch units (A, B; C, D) via a connection node (5, 6),*

**characterized in that**

*between the at least two connection lines (7, 8), a circuit arrangement (E, DE, F, DF, 9, 10, 11) is provided which may be controlled such that the circuit arrangement electrically connects the at least two connection lines (7, 8) in a first state and electrically separates the at least two connection lines (7, 8) in a second state.*

*9. A method for feeding the energy originating from a solar generator to a grounded network, the method comprising the steps of:*

*during at least a section of a half-wave of the alternating voltage of the network, connecting and separating a first terminal of an energy buffer (C1) to a first choke inductivity (L1) and a second terminal of the energy buffer (C1) to a second choke inductivity (L2) in a clocked manner;*

*during at least a section of a next half-wave of the alternating voltage of the network, connecting and separating the first terminal of the energy buffer (C1) to the second choke inductivity (L2) and the second terminal of the energy buffer (C1) to the first choke inductivity (L1) in a clocked manner;*

**characterized by:**

*separating the terminals of the energy buffer (C1) from the first choke inductivity (L1) and from the second choke inductivity (L2) when the first choke inductivity (L1) and the second choke inductivity (L2) are electrically connected to each other on their respective sides facing away from the network.*

## Claim construction

11. Before proceeding I must construe claims 1 and 9. I must interpret the claims in light of the description and drawings as required by Section 125(1) and take account of the Protocol on the Interpretation of Article 69 of the EPC as required by section

125(3). In doing so, I must give the claims a purposive construction<sup>1</sup> and ask what the person skilled in the art would have understood the patentee to be using the language of the claims to mean.

*Identity of the person skilled in the art*

12. In the earlier opinion, the identity of the skilled person was defined as, “an electrical engineer with knowledge of inverters for converting direct current voltages to alternating current voltages” (paragraph 15). In their observations, the observer offers a narrower definition of the skilled person, asserting that “the person skilled in the art may be considered an electrical engineer having experience in the fields of solar technology and inverters for solar generators”. In their observations in reply, the requester says the observer’s definition “is an obvious deviation or misinterpretation” of paragraph 15 of the earlier opinion and that the observer “fails to submit any evidence showing that the skilled person would be specialized in photovoltaic applications without at the same time being specialized in the design of inverters in general”. The requester goes on to argue that the evidence shows that the broader definition of the skilled person is justified.
13. In evaluating these arguments, I have considered whether the parties are, effectively, asking me to provide a *second opinion* on a matter (the identity of the skilled person) that has already been covered by the earlier opinion. The opinions procedure is intended to be a relatively quick and simple procedure and, consequently, it is a general principle that a request for an opinion cannot go over old ground by raising arguments that have been sufficiently considered in a previous opinion<sup>2</sup>. However, given that the requester has provided additional evidence and argument on the matter, I believe it is appropriate to for me consider the additional evidence and argument.
14. Firstly, the requester argues there was no distinct field of “solar power electronics” (i.e. as distinct from power electronics) at the priority date. They refer to “the standard textbook of Erickson<sup>3</sup>” that (they say) confirms that photovoltaic applications are just one of many applications of power electronics. Secondly, the requester points out that the patent itself is not restricted to photovoltaic applications and is not based on prior art concerning photovoltaic applications. For example, the requester says that the references given at page 1, lines 22 – page 2, line 3 are general textbooks concerning power electronics and inverters and that they demonstrate that photovoltaic applications are exemplary applications of power electronics. The requester also says that page 1 (lines 1-8) of the patent itself defines its technical field to be broader than merely for photovoltaic applications:

*The invention relates to an inverter (or DC/AC converter) for transforming a direct electric voltage to an alternating current or alternating voltage. Current converters of this kind are used, for example, for feeding electrical energy into the public power supply network or for forming an independent island network for being used in cases in which only direct voltage energy sources are*

---

<sup>1</sup> In *Generics UK Ltd (t/a Mylan) v Yeda* [2017] EWHC 2629 (Pat), Arnold J confirmed (at 134) the continuing requirement to interpret patent specifications purposively, having considered the earlier judgment of the UK Supreme Court in *Actavis v Eli Lilly* [2017] UKSC 48.

<sup>2</sup> See Rule 94(1)(b) and sections 1.1 and 3.3 of the Opinions manual.

<sup>3</sup> Erickson, *Fundamentals of Power Electronics*, 2<sup>nd</sup> Edition, 2001, Kluwer Academic Publishers, p. 8

available, such as, for example, photovoltaics systems, fuel cells, batteries, etc. (Requester's emphasis.)

Similarly, the requester also refers to page 12 (lines 1-4) that states the connection to a solar generator is optional and to page 19, line 28 – page 20, line 1 that states the energy source for the inverter may be a solar generator, battery storage or a fuel cell. I agree with the requester. I believe that the teachings of the patent are not solely limited to solar applications. In my opinion, it is reasonable to conclude (as I did in the earlier opinion) that the skilled person is an electrical engineer with knowledge of inverters for converting direct current voltages to alternating current voltages. I would add that I believe the title of the patent (“Inverter for converting an electric direct current into an alternating current or an alternating voltage”) also supports this conclusion.

#### *Construction of claims 1 and 9*

15. I believe that claims 1 and 9 are generally straightforward to construe. However, there are two points of construction that are relevant to deal with. Firstly, claim 1 defines “An inverter for feeding the energy originating from a solar generator to a grounded network”. I believe the skilled person would interpret this as meaning that claim 1 is seeking protection for an inverter that this *suitable* for the purpose of feeding the energy originating from a solar generator to a grounded network. In other words, the skilled person would understand the patentee to be claiming protection for an inverter (suitable for that purpose) and not a combination of an inverter and a solar generator or a combination of an inverter and a grounded network. Secondly, the “solar generator terminals” defined at line 2 would, I believe, be understood as terminals *suitable* for connection to a solar generator.

#### **a) Inventive step over RAO**

16. The approach that must be taken for deciding whether an invention involves an inventive step is the *Windsurfing/Pozzoli* approach:

*(1)(a) Identify the notional “person skilled in the art”*

*(1)(b) Identify the common general knowledge of that person;*

*(2) Identify the inventive concept of the claim in question or if that cannot be readily done, construe it;*

*(3) Identify what, if any, differences exist between the matter cited as forming part of the “state of the art” and the inventive concept of the claim or the claim as construed.*

*(4) Viewed without any knowledge of the alleged invention as claimed, do those differences constitute steps that would have been obvious to the person skilled in the art or do they require any degree of invention?*

This the approach that I shall follow. The requester asks for an opinion on whether claims 1 and 9 involve an inventive step over RAO. I shall begin with claim 1.

*Steps 1(a) & 1(b): identify the notional “person skilled in the art” and the common*

*general knowledge of that person*

17. As already discussed above, the person skilled in the art is an electrical engineer with knowledge of inverters for converting direct current voltages to alternating current voltages. Regarding the common general knowledge of the skilled person, the requester argues that the use of choke inductivities or EMI filters (that also comprise inductivities) for smoothing the output of inverters or for reducing electromagnetic interference would have been common general knowledge at the priority date of the patent. They say this is evidenced by page 4, line 23 – page 5, line 2 of the patent and also by nine other prior-art documents. I will now consider the evidence that the requester has cited.
18. Page 4, line 23 – page 5, line 2 discusses features of the prior-art topology shown in Fig. 2 of the patent. Fig. 2 shows a single-phase inverter connected between a solar generator and an AC power grid. The output lines 7, 8 of the inverter comprise choke inductivities  $L_1$ ,  $L_2$  respectively “to obtain a smooth current or voltage course at the output of the alternating voltage terminals 3, 4.” Page 4 (lines 23-25) also teaches that the alternating voltage can be used to feed into either an AC grid or (in “island operation”) to drive a load.
19. Four of the other prior art documents highlighted by the requester show single-phase inverters that feed energy from a solar generator to an AC grid where inductances are provided in the output lines of inverters:

“A power converter for Photovoltaic Applications”, February 2000, by Björn Lindgren (“LINDGREN”) – Fig. 15 shows a “conventional configuration” for a photo-voltaic system including a single-phase inverter where each output line of the inverter is provided with a series inductivity;

EP 1107439 A2 (“EP ‘439”) – Fig. 3 shows a single-phase inverter 12 for a solar battery that comprises inductivities 32, 33 in each output line;

US 2001/0048605 A1 (“US ‘605”) – Fig. 1 shows an inverter 6 for a solar battery 1 where the output lines of the inverter each comprise an inductivity 7; and

“Vereinfachung photovoltaischer Systemtechnik durch neue Stromrichterkonzepte” by Dirk Schekulin et al. (“SCHEKULIN”) – Fig. 3 on page 5 shows an inverter having inductivities  $L_{21}$  and  $L_{22}$  provided in its respective output lines<sup>4</sup>.
20. I believe it is reasonable to conclude from these four documents, and from page 4, line 23 – page 5, line 2 of the patent, that the use of choke inductivities in the output lines of *single-phase inverters in combination with solar generators* was part of the common general knowledge of the skilled person at the priority date.
21. Of the remaining prior art documents, I believe two of them show the use of multi-

---

<sup>4</sup> I note that no explicit publication date is given in SCHEKULIN. However, because this paper is, apparently, part of a wider publication entitled “FORSCHUNGSVERBUND SONNENENERGIE „THEMEN 96/97””, I believe it is reasonable to conclude on the balance of probabilities that this paper was made available to the public in 1996 or 1997, i.e. well before the priority date of the patent.

phase LC filters at the outputs of multi-phase inverters that are used to drive inductive loads:

JULIAN – page 35 shows a three-phase DC/AC inverter where a second order filter, comprising an inductance  $L_f$  provided in the respective output lines of a three-phase inverter, is provided between the inverter and an inductive load; and

US '558 – Fig. 1 shows a four-phase LC filter 72 provided at the output of a four-phase inverter that is used for driving an inductive load (a motor), where the LC filter comprises a serial inductivity in each output line of the inverter.

Another of the remaining prior art documents WO 00/51225 (“WO ‘225”) shows a three-phase inverter of general application where inductors are provided in the output lines in order to reduce harmonic vibrations provided to a multi-phase load. I believe it is reasonable to conclude from these three documents that the use of serial inductances (or LC filters comprising serial inductances) in the output lines of *multi-phase* inverters for driving *multi-phase* loads was common general knowledge at the priority date of the invention.

22. However, I note that, of the evidence I have considered thus far, only page 4, line 23 – page 5, line 2 of the patent and EP ‘439 (see e.g. Figs. 1 & 2) mention the use of choke inductivities in connection with *single-phase* inverters when driving loads. I do not believe that this evidence is sufficient to demonstrate that it was common general knowledge to use choke inductivities in the output lines of *single-phase* inverters when driving *inductive loads* such as motors.
23. For completeness, I will discuss the final two of the nine documents cited by the requester. The background of the invention section of EP 0881759 A2 (“EP ‘759”) discloses the use of input and output EMI filters in sub-resonant DC-AC converters. However, EP ‘759 does not appear to specify what such EMI filters might comprise so I have not found it particularly helpful. Lastly, I note that EP 1235339 A2 (“EP 339”) was published after the priority date so I have disregarded it.

*Step (2) Identify the inventive concept of the claim in question or if that cannot be readily done, construe it*

24. There does not appear to be any dispute over the inventive concept of claim 1. The inventive concept is that defined by claim 1 as construed above.

*Step (3) Identify what, if any, differences exist between the matter cited as forming part of the “state of the art” and the inventive concept of the claim or the claim as construed*

25. It is common ground between the parties that the earlier opinion concluded that RAO was novel over claim 1 because RAO does not disclose feature 1.4.1.1 of claim 1 (as numbered in the request). That is, the inverter of RAO does not disclose respective choke inductivities in the connection lines extending between the parallel branches of the inverter and the AC terminals connected to the load, as required by claim 1. I agree. Fig. B.1 on page 139 of RAO (reproduced below) illustrates a single phase inverter connected to an “Inductive Load” shown on the right-hand side of Fig. B.1.



The difference between RAO and claim 1 is that neither of the connection lines of RAO includes choke inductivities as required by claim 1.

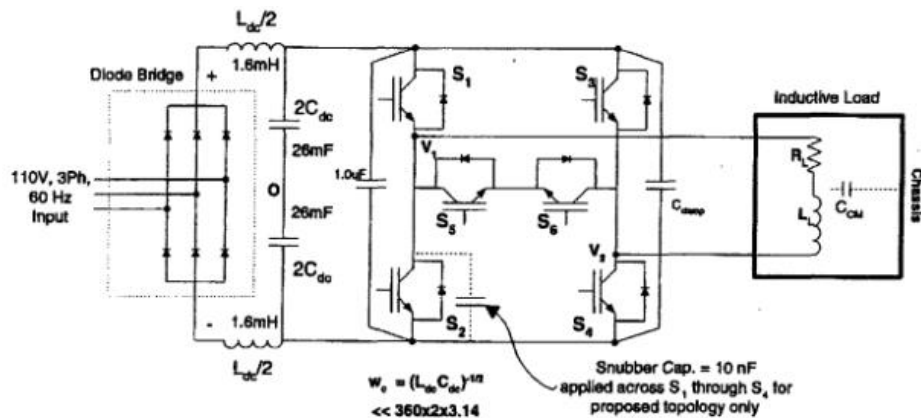

Figure B.1: Schematic Power Circuit Diagram for Laboratory Prototype Inverter

Step (4) Viewed without any knowledge of the alleged invention as claimed, do those differences constitute steps that would have been obvious to the person skilled in the art or do they require any degree of invention?

26. The requester makes two arguments in respect of obviousness. Firstly, the requester refers to the earlier opinion and says that, “the Examiner states in paragraph 44 that he accepts that RAO mentions a freewheeling state and that inductances in the output lines are common components of inverter topologies”. The requester uses this to argue that, “in making this statement the Examiner is confirming that it would have been obvious to the skilled addressee with knowledge of RAO to include features 1.4.1.1 in the output lines”. I disagree. The earlier opinion was only concerned with the question of the novelty of the claims over RAO. Paragraph 44 reaches the conclusion that claim 1 is novel over RAO and that is all. It cannot be read as making any statement or conclusion concerning the obviousness of claim 1 in light of RAO.
27. Secondly, the requester argues that it would be obvious to include choke inductivities in the output lines of RAO in light of the common general knowledge discussed above. The observer disagrees. The observer’s main argument is that RAO describes “electrical drive engineering” which would cause the skilled reader to *disregard* RAO because RAO is not concerned specifically with the field of solar technology. I think the observer is right to point out that Fig. B.1 of RAO is concerned with electrical drive engineering. I believe the skilled person would understand that Fig. B.1. shows a prototype inverter that is driving an inductive load having a chassis. I believe the skilled person would also understand that Fig. B.1 shows a *single-phase* inverter. I believe the relevant question I must therefore ask is: would it have been obvious to the skilled person, in light of their common general knowledge at the priority date, to include choke inductivities in the output lines of the single-phase inverter that is driving the inductive load illustrated in Fig. B.1 of RAO? Based on the information provided to me, I believe the answer is no, it would not be obvious so to do. This is because, based on the information provided to me, I do not believe it was common general knowledge at the priority date to use choke inductivities in the output lines of *single-phase* inverters when driving *inductive loads* such as motors (as I noted at paragraph 22 above).

28. Turning now to claim 9, it follows that claim 9 is non-obvious for essentially similar reasons. Fig. B.1 of RAO does not disclose the first and second inductivities required by claim 9. In my opinion, it would not be obvious to the skilled person, in light of their common general knowledge at the priority date, to include these inductivities in Fig. B.1. of RAO.
29. In my opinion, claims 1 and 9 involve an inventive step over RAO.

## b) Novelty over JULIAN

30. The requester asks for an opinion on whether claims 1 and 9 are novel over JULIAN. The requester has filed evidence that shows that JULIAN was made available to the public well before the priority date of the patent and this is not disputed by the observer.

### Claim 1

31. The requester refers to pages 76 and 77 and Fig. 5.4 of JULIAN (reproduced below) and argues that all of the features of claim 1 are disclosed by JULIAN. The observer disagrees and says that at least the following features (numbered according to the numbering used in the request) are not disclosed by JULIAN:

- 1 *An inverter for feeding the energy originating from a solar generator to a grounded network*
- 1.1 *the inverter comprises two solar generator terminals*
- 1.2 *the inverter comprises an energy buffer for buffering the energy originating from the solar generator*
- 1.3.1 *the bridge circuit is connected in parallel to the energy buffer*
- 1.4.1.1 *in each of the connection lines one respective choke inductivity is provided.*

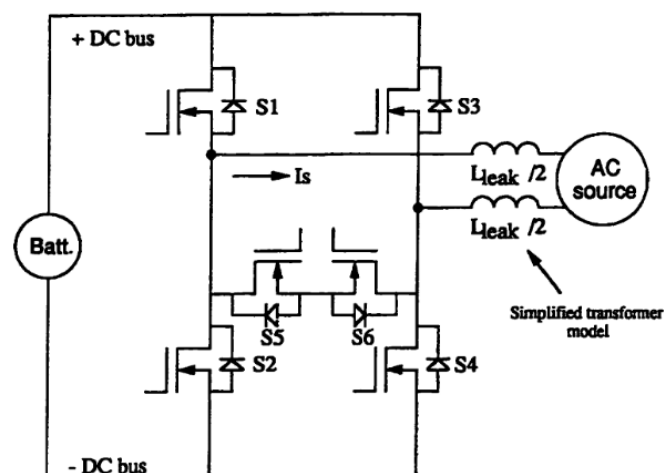

Figure 5.4: Single Phase Inverter Topology

32. I agree with the requester that the skilled person would understand that the inverter of Fig. 5.4 is *suitable for* feeding the energy originating from a solar generator to a grounded network. Although the inverter of Fig. 5.4 is shown in combination with a battery, the skilled person would understand the inverter connected to the battery could be used, alternatively, with a solar generator without any modification of the inverter. I also agree with the requester that the two (implied) terminals that connect the inverter to the battery would be understood as being *suitable for* connection to a solar generator, as required by feature 1.1. In my opinion, features 1 and 1.1 are disclosed by JULIAN. However, having accepted these points, I think it plain to say that features 1.2 and 1.3.1 cannot also be disclosed by Fig. 5.4. I agree with the observer that there is, simply, no disclosure of an energy buffer as required by features 1.2 and 1.3.1.
33. I also agree with the observer that feature 1.4.1.1 is not disclosed by JULIAN. The requester seeks to equate the two leakage inductances, shown in the connection lines on the right-hand side of Fig. 5.4, with the choke inductivities of feature 1.4.1.1. However, I agree with the observer that the skilled person would understand from page 76 of JULIAN that the AC source shown in Fig. 5.4 is an AC source transformer, noting JULIAN teaches that, "In Fig. 5.4 the transformer is modeled simply with the leakage inductance." Therefore, I believe that the skilled person would understand that the leakage inductances shown in Fig. 5.4 are entirely a feature of the AC transformer and not a feature of the inverter (a point that I believe is emphasised further by the explicit connection points shown at the mid-point of each leg of the bridge in Fig 5.4). In my opinion feature 1.4.1.1 is not disclosed by JULIAN.
34. In my opinion claim 1 is novel over JULIAN because features 1.2, 1.3.1 and 1.4.1.1 are not disclosed by JULIAN.

#### *Claim 9*

35. My opinion that JULIAN does not disclose the two choke inductances of claim 1 means that claim 9 must be novel for the same reason (because JULIAN cannot disclose the first and second choke inductivities defined in claim 9). In addition, I also accept the observer's argument that JULIAN, plainly, does not disclose any method of operating the switches shown in Fig. 5.4 as a function of the half-waves of the alternating voltage in the network, as required by lines 3-9 of claim 9. I also agree with the observer that JULIAN does not disclose feeding energy from a solar generator to a grounded network required by claim 9.
36. In my opinion claim 9 is novel over JULIAN.

### **c) Novelty over US '558**

37. The requester asks for an opinion on whether claim 1 only is novel over US '558. The requester refers specifically to Fig. 13 of US '558 (reproduced below), and the associated description in columns 17-18, to argue that all of the features of claim 1 are disclosed by US '558, as set out in the table on pages 12-14 of the request. On the other hand, the observer argues that at least features 1, 1.1, 1.2 and 1.4.1.1 (set out above) are not disclosed by US '558.

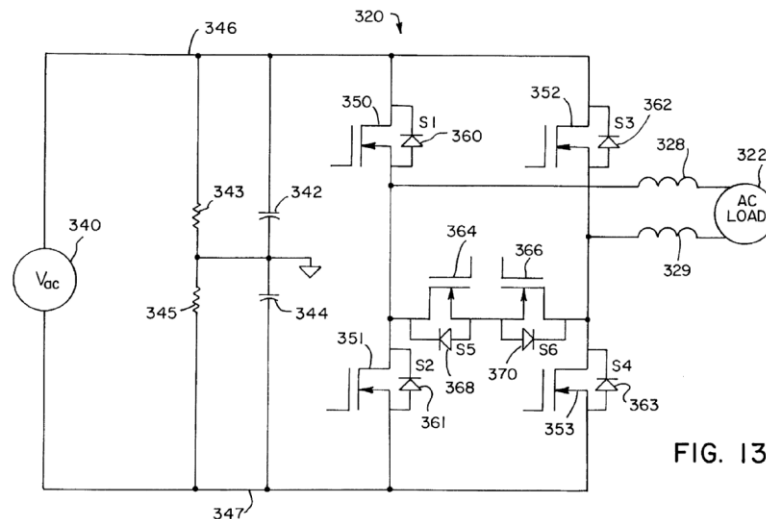

FIG. 13

38. Having considered the parties' submissions carefully, I agree with the requester's analysis (set out in the table on pages 12-14 of the request) that US '558 discloses all of the features of claim 1 except for their argument on feature 1.4.1.1. In the request, the requester equates impedances 328 and 329 of Fig. 13 with the choke impedances of feature 1.4.1.1. The observer responds by pointing out (in my opinion, correctly) that column 17, lines 40-41 states that, "In this case, the load 322 is characterized by leakage inductances 328 and 329." Thus, I agree with the observer that (as was the case with JULIAN) the skilled person would understand that inductances 328 and 329 are leakage inductances of the load. The skilled person would understand that they are entirely a feature of the load and are not a feature of the inverter. (Again, I think this conclusion is reinforced by the inclusion in Fig. 13 of explicit connection points at the mid-point of each leg of the inverter.) In my opinion, the skilled person would understand that the leakage inductances 328, 329 are not choke inductivities within the meaning of feature 1.4.1.1.

39. In their observations in reply, the requester makes an alternative argument. They say that inductances 328 and 329 are part of an LC filter that is a separate part of the inverter and do not belong to the load 322. In support, the requester refers to me to column 4, lines 58-63 of US '558 which states that:

*In order to maximize common mode voltage reduction, the multi-phase load to which the inverter is connected preferably presents a balanced impedance to the inverter. A balanced impedance on the inverter outputs may be achieved using a multi-phase LC filter connected between the inverter leg outputs and the load.*

In my opinion, this passage does not support the requester's argument. The skilled person would understand that this passage teaches that a multi-phase LC filter may be connected between inverter leg outputs and a multi-phase load. In my opinion, this passage *does not* provide a clear and unmistakable direction to the skilled person that the leakage inductances 328 and 329 are part of such an LC filter.

40. In my opinion, claim 1 is novel over US '558 because feature 1.4.1.1 is not disclosed by US '558.

## d) Added matter

41. The requester asks for an opinion on the validity of claim 9 of the patent in respect of added matter. The requester's view is that claim 9 is invalid because claim 9 goes beyond the disclosure of the parent application, EP03009882.6, from which the patent is divided.

*Added matter – the Law*

42. The relevant provisions of the act dealing with the validity of patents in respect of added matter are found in section 72(1)(d):

*72.-(1) Subject to the following provisions of this Act, the court or the comptroller may by order revoke a patent for an invention on the application of any person (including the proprietor of the patent) on (but only on) any of the following grounds, that is to say -*

*(a) ... ;*

*(b) ... ;*

*(c) ... ;*

***(d) the matter disclosed in the specification of the patent extends beyond that disclosed in the application for the patent, as filed, or, if the patent was granted on a new application filed under section 8(3), 12 or 37(4) above or as mentioned in section 15(9) above, in the earlier application, as filed;***

*(e) ... .*

43. In this case, the patent was granted on a divisional application of the parent application. Thus, for the purposes of this section, the patent is treated as “the patent ... granted on a new application ... as mentioned in section 15(9)” and the parent application is treated as the “the earlier application”.

44. The test for added matter was stated by Aldous J. in *Bonzel v Intervention (No 3)* [1991] R.P.C. 553 at 574 in these terms:

“The decision as to whether there was an extension of disclosure must be made on a comparison of the two documents read through the eyes of a skilled addressee. The task of the Court is threefold:

(1) To ascertain through the eyes of the skilled addressee what is disclosed, both explicitly and implicitly in the application.

(2) To do the same in respect of the patent,

(3) To compare the two disclosures and decide whether any subject matter relevant to the invention has been added whether by deletion or addition. The comparison is strict in the sense that subject matter will be added unless such matter is clearly and unambiguously disclosed in the application either explicitly or implicitly.”

As summarised by Jacob J. in *Richardson-Vicks Inc.'s Patent* [1995] RPC 568:

“the test of added matter is whether a skilled man would, upon looking at the amended specification, learn anything about the invention which he could not learn from the unamended specification.”

In *Nokia Corporation v IPCOM GMBH & Co KG (No. 3)* [2013] R.P.C. 5, Kitchin LJ considered whether matter had been added by omission with reference to the “Houdaille Test” set out by the EPO Board of Appeal in T331/87 Houdaille/Removal of feature [1991] E.P.O.R. 194. The test was summarised by Kitchin LJ:

“The skilled person must be able to recognise directly and unambiguously that (1) the [omitted] feature is not explained as essential in the original disclosure, (2) it is not, as such, indispensable for the function of the invention in light of the technical problem it serves to solve, and (3) the replacement or removal requires no real modification of other features to compensate for the change.”

#### *Application of the Bonzel test*

45. I have been asked to consider whether the disclosure of the patent extends the disclosure of the earlier (parent) application. Therefore, I must apply the *Bonzel* test by comparing the disclosure of *the parent application*, as filed, with the disclosure of the patent. In summary, I must ask whether the skilled person would, upon looking at the patent specification, learn anything about the invention which they could not learn from the specification of the parent application, as filed.

#### *(1) Disclosure of the parent application*

46. The requester says that the description of the parent application is the same as that translated into English for DK/EP 2086102 T3 (mentioned at paragraph 2 above), i.e. that the description of the parent application is the same as the description of the patent. This is not disputed by the observer. With the exception of the reference to claim 9 under the “Presentation of the invention” section (page 10, line 17), I agree with the requester. I note that page 10, line 17 corresponds to paragraph [0030] of the original (German-language) description of the parent application and that this paragraph only refers to original claims 1, 10 and 20.
47. The requester says that the parent application “does not contain any method claims”. Again, this is not disputed by the observer. Notwithstanding original claims 20-24, I agree with the requester. Although claims 20-24 are not “method” claims, I believe that original claims 20-24 relate to the “Use of the inverter according to one of claims 1 to 20...” (“Verwendung des Wechselrichters nach einem der Ansprüche 1 bis 20 ...”) and are therefore claims in the process (e.g. method) category. I believe that the skilled person would understand that original claims 20-24 are dependent upon the inverter defined by original claim 1. In any case, I agree with the requester that the parent application, as filed, does not contain a claim that is the same as claim 9 of the patent.
48. The requester argues that the description of the parent application “exclusively and expressly describes the method for feeding current into a grounded network on the basis of the topology according to the invention pursuant to claim 1 [of the patent]”. In support, the requester relies upon page 14, lines 15-20, of the description of the parent application:

“The mode of operation of the inventively formed inverter is done in accordance with the symmetrical clocking, discussed above, of the switch units A, B, C, D provided in the bridge circuit, i.e. in dependence on the polarity of the half-waves of the network voltage  $U_{\text{network}}$ , the switch pairs A and D and B and C are closed and opened following a fixed clock pattern. The time behaviour using which the individual switch units A-D are switched is illustrated in Figs. 7 and 10.” (Requester’s emphasis.)

49. The observer disagrees. They say that the skilled person would interpret the disclosure of the parent application more broadly. They say that, “a person skilled in the art ... will find that the exact topology, in particular the design of the bridge circuit, is not crucial for the inventive method. Rather, what is essential in terms of solving the problem discussed in the introductory part of the specification ... is the connection/separation of the terminals of the buffer capacitor and of the choke inductances. This essential aspect is explained by means of equivalent circuit diagrams, without any reference to the design of the inverter.” (Observer’s emphasis.) The observer refers specifically to Figs. 5-7 (and the associated description) and argues that the skilled person would be particularly influenced by the equivalent circuit diagrams shown in Fig 5. They say that the skilled person would understand the equivalent circuit diagrams to reveal a general teaching of separating/connecting the buffer capacitor and choke inductances in order to solve the problems outlined in the introductory part of the description. Therefore, the observer says, the skilled person would understand from the equivalent circuit diagrams that *any* inverter topology may be employed to solve the problems set out in the description, as long as the inverter topology allows the circuit states depicted in the equivalent circuit diagrams to be achieved.
50. I do not accept the observer’s argument that the skilled person would understand that the essential aspect of the invention is explained by the equivalent circuit diagrams of Fig. 5 without any reference to the design of the inverter. On the contrary, I believe that the skilled person would understand that the description in respect of Figs. 5 and 7, upon which the observer relies, refers to the description of the inverter of Fig. 1. Firstly, I note that when Fig. 5 is described on page 16, lines 6-7, it is stated that,

“The following potential conditions illustrated in detail in Figs. 5 and 6 result during operation of the inverter with symmetrical clocking” (my emphasis).

And when Fig. 5 is introduced earlier (page 13, lines 1-2) it is stated that,

“Fig. 5 shows equivalent circuit diagrams for explaining the potential behaviour in the inventively formed inverter” (my emphasis).

From these passages I believe the skilled person would understand that the description of Fig. 5 refers to the “inventively formed inverter” that is described in relation to Fig. 1 (see page 12, lines 22-23 and page 13, line 19 – page 14, line 20). Secondly, I believe that the skilled person would also understand that Fig. 7 shows an example of operating the “inventively formed inverter” of Fig. 1. I believe that this would be understood from the passage the requester highlights (page 14, lines 15-20) and also from Fig. 7 itself. I believe the skilled person would understand from the description of Fig. 7 (page 15, line 1 – page 16, line 4) that it is an example of the

how the switches A, B, C, D, E and F in the topology of Fig. 1 are operated (e.g. as explained at paragraph 8 above). I believe that the skilled person would understand from pages 14-17 that Fig. 7 explains how switches A-F of Fig. 1 are operated in order to produce certain states of the inverter of Fig. 1 and that these states are represented by the equivalent circuits shown in Fig. 5 (e.g. as explained at paragraph 9 above). In particular, I believe that the skilled person would understand that when switch E is closed and switches A and D are open (page 15, line 30 – page 16, line 1) the equivalent circuit diagram of Fig 5b results (page 16, lines 11-13). And when switch F is closed and switches B and C are open (page 16, lines 2-4) the equivalent circuit diagram of Fig. 5d results (page 16, lines 13-14).

51. Thus, when reading the parent application, I believe the skilled person would understand that the equivalent circuit diagrams of Fig. 5 are not a general teaching to be read in isolation. Instead, I believe the skilled person would understand that Fig. 5 is an aid to understanding the operation of the “inventively formed inverter” of Fig. 1 (that is described in relation to Fig. 7). I therefore agree with the requester’s view of what is disclosed by the parent application. In my opinion, the skilled person would understand from pages 14-17 that features of the topology of “the inventively formed inverter” of Fig. 1 are *essential* to the method of operating the (same) inverter that is described on pages 14-17. In my opinion, the skilled person would understand that the essential features of the inverter of the parent application are the same as the features of the inverter defined by claim 1 of the patent. I would add that I believe this is entirely consistent with what the skilled person would learn from the parent application when read as a whole. (See for example: the “Presentation of the invention” section (page 10, lines 5 – 15 and page 10, line 22 – page 12, line 14); the description of Fig. 1 (page 13, lines 19-30); the alternative embodiments described on page 19, line 16 – page 21, line 8 and illustrated in Figs. 9 & 10; and original claims 1-24.)

### *(2) Disclosure of the patent*

As I have already said, the description of the parent application and the description of the patent are practically the same. This means that the relevant disclosure of the patent I must now consider is that of claim 9 of the patent. The requester says that claim 9 does not contain any restriction to the use or operation of only the “inventively formed inverter”, i.e. that that claim 9 is not limited to the inverter defined by claim 1 of the patent. Instead, the requester says, claim 9 relates to a general method for feeding the energy into a grounded network. The observer does not appear to dispute this. I agree with the requester. I believe the skilled person would understand that claim 9 discloses a general method of feeding energy from a solar generator to a grounded network. The method involves connecting and separating an energy buffer (having first and second terminals) and two choke inductivities in a clocked manner during successive half-waves of the alternating voltage of the network (as set out in the pre-characterising portion of claim 9). From the characterising portion of claim 9, the skilled person would understand that claim 9 discloses that it is necessary to separate the terminals of the energy buffer from the choke inductivities when the inductivities are electrically connected on their respective sides that face away from the grounded network.

### *(3) Comparison of the two disclosures – has any subject matter relevant to the invention been added by deletion or addition?*



52. The requester says that the more general teaching of claim 9 is not originally disclosed by the parent application and that, therefore, the disclosure of claim 9 of the patent goes beyond that of the parent application. The requester supports this by arguing that claim 9 does not only cover the topology of claim 1 of the patent but all other topologies providing a freewheeling state. The requester gives numerous examples of topologies that are allegedly covered by claim 9, including examples of free-wheeling states that are allegedly produced by switching the prior-art topology of Fig. 2 of the patent. The requester argues that the applicant has not sought protection for such topologies and that those topologies were not the subject matter of the parent application. In their observations in reply, the requester goes further to suggest that because claim 9 covers all other topologies providing a freewheeling state, “claim 9 would not be novel”. I do not find the requester’s line of argument particularly helpful because it seems to me that it focusses on what claim 9 *covers* rather than what it *discloses*. As I understand the *Bonzel* test, it is a strict test of *disclosure*. It is the disclosures of the parent application and the patent, seen through the eyes of the skilled person, that I must compare to ascertain whether matter relevant to the invention has been added by deletion or addition.
53. The observer argues that “claim 9 is directly and unambiguously derivable from the parent application” and that there is “no unallowable extension of subject matter”. I do not believe that comparison of the parent application and the patent supports the observer’s argument. As I have set out above, I believe the skilled person would understand from the parent application that it does not contain a claim corresponding to claim 9 of the patent. Thus, the subject matter of claim 9 of the patent is not presented as having inventive significance in the original parent application. I also believe, the skilled person would understand from the parent application that certain features of the inverter of Fig. 1 of the parent application (i.e. the features of the inverter defined in claim 1 of the patent) are *essential* to the method of operating the inverter disclosed in the parent application. On the other hand, I believe the skilled person would understand from claim 9 of the patent that it discloses a more general method which *omits* to define many of the features of the inverter that would be understood as essential from the parent application (i.e. that claim 9 omits to define the features of the inverter defined in claim 1 of the patent). For example, claim 9 omits to define that an inverter is required or that the inverter comprises a bridge circuit comprising parallel branches or that there are connection lines for connecting each parallel branch to the grounded network. Claim 9 also omits to define that a circuit arrangement is provided between the connection lines that is operable to connect and disconnect the connection lines.
54. In order to decide whether these omissions result in a disclosure of added matter, I must apply the “Houdaille Test” in the summarised form approved in *Nokia*. In my opinion, each of the three questions of the test would be answered negatively. Firstly, I believe the skilled person would understand from the parent application that the omitted features are *essential* to the operation of the inverter (as I have already discussed above). Secondly, I believe the skilled person would understand from the parent application that the omitted features are precisely the means by which the problems addressed by the invention are solved (see e.g. page 13, lines 19-30). Thirdly, I believe the skilled person would recognise that omitting the essential features of the inverter would inevitably require modification of other features to compensate for this omission in order to solve the problems identified in the parent

application.

55. It follows that I do not agree with the observer that claim 9 is directly and unambiguously derivable from the parent application. In my opinion, there is no clear and unambiguous disclosure in the parent application that teaches the skilled person that the features omitted from claim 9 are not essential. In my opinion, the skilled person would, upon looking at claim 9 of patent, learn something about the invention which they could not learn from the parent specification, namely, that the method of operating the inverter is achieved without requiring all of the features of the inverter topology that are taught as essential in the parent application. Thus, ultimately, I agree with the requester that claim 9 is invalid for added matter.
56. In my opinion, claim 9 of the patent extends the disclosure of the parent application and, consequently, claim 9 of the patent is invalid for added matter.

## **Opinion**

57. It is my opinion that:
  - a) claims 1 and 9 involve an inventive step over RAO;
  - b) claims 1 and 9 are novel over JULIAN;
  - c) claim 1 is novel over US '558; and
  - d) claim 9 invalid because it discloses added matter.

## **Application for review**

58. Under section 74B and rule 98, the proprietor may, within three months of the date of issue of this opinion, apply to the comptroller for a review of the opinion.

Stephen Richardson  
Examiner

---

## **NOTE**

*This opinion is not based on the outcome of fully litigated proceedings. Rather, it is based on whatever material the persons requesting the opinion and filing observations have chosen to put before the Office.*