

OPINION UNDER SECTION 74A

Patent	EP 2385261 B1
Proprietor(s)	Chang, Chia-Ming Kaohsiung (TW)
Exclusive Licensee	-
Requester	Appleyard Lees
Observer(s)	Chang, Chia-Ming
Date Opinion issued	30 August 2017

The request

1. The comptroller has been requested to issue an opinion as to whether EP 2385261, the Patent, is valid in the light of a number of pieces of prior art by Appleyard Lees. In their request, Appleyard Lees suggest that the patent lacks an inventive step over four Taiwanese patent documents and three US patent documents. Appleyard Lees have provided English language translations of these Taiwanese documents, which the observer has not questioned. I shall therefore base my opinion on these translations.
2. In their observations Nash Matthews on behalf of Chang, Chia-Ming, suggest possible amendment to the application, which they suggest might clarify the term “common line” and correct numbering in the drawings. It is of course open to Chang to pursue such amendments, however, my opinion is necessarily limited to the patent as it stands following grant by the EPO. No observations in reply were filed by Appleyard Lees. Under section 74B and rule 98, the proprietor may, within three months of the date of issue of this opinion, apply to the comptroller for a review of the opinion.

The Patent

3. The Patent was granted by the EPO on the 3rd July 2013 and is currently in force. The Patent relates to a self-tapping screw, with a particular arrangement of a cutting slot (with a chip evacuation surface and an arced cutting surface) and an evacuation slot. An example of this can be seen in the figures of the application, for example figures 7 and 8.

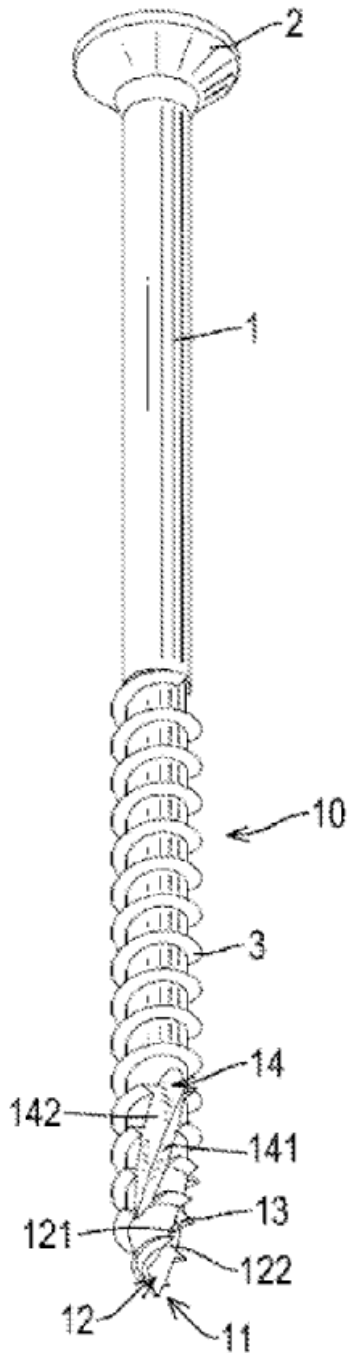

FIG. 7

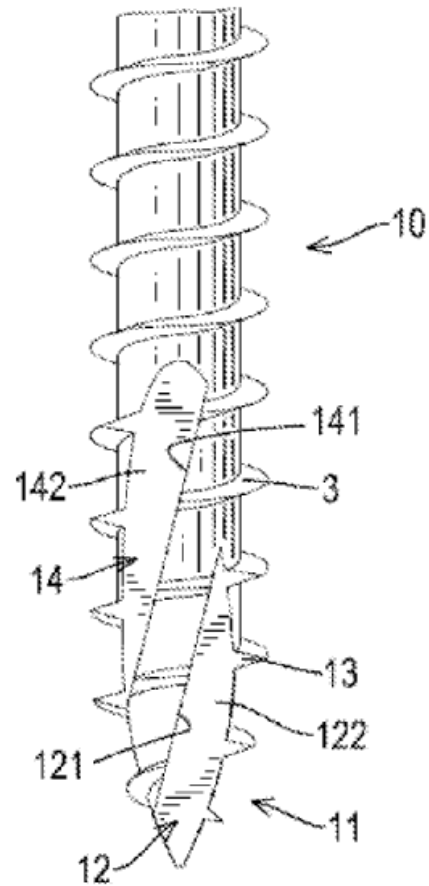

FIG. 8

4. As noted by both the requester and the observer, the art of self-tapping screws is well established, and the use of V-shaped slots in the acting portion of the screw is known. However, as I shall set out below, the debate in this case focusses on the nature of this evacuation slot, 14.

5. The Patent itself has twelve claims, and a single independent claim which reads:

A self-tapping screw comprising:

*a shank (1) having a center axis, a periphery, a top and a lower portion;
a head (2) formed on the top of the shank (1); and
an acting portion (10) formed in the lower portion of the shank (1) and
having:*

a periphery;

a tip portion;

*a threaded portion (3) having a helical thread formed around the periphery of
the acting portion (10); a tapered cone (11) formed on the tip portion of the
acting portion (10) and having a tip;*

*a cutting slot (12) formed in the acting portion (10), being tilted relative to the
center axis of the shank (1) and extending from the tapered cone (11) in a
direction toward the head (2) and having:*

*a chip evacuation surface (121) being tilted relative to the center axis
(4) of the shank (1); and*

*an arced cutting surface (122) connected with the chip evacuation
surface (121) at a common edge thereof of the arced cutting surface
(122) and the chip evacuation surface (121) to form a V-shaped
section, upwardly extending from the tip of the tapered cone (11), and
having a blade portion (13) formed by a portion of the arced cutting
surface (122) intersecting with the periphery of the shank (1) and the
threaded portion (3); and*

characterized in that the acting portion further has:

*a first evacuation slot (14) formed in the acting portion (10), being tilted
relative to the center axis of the shank (1), upwardly extending toward the
head (2) and having:*

*a first surface (141) being tilted relative to the center axis (4) of the
shank (1) and parallel to the chip evacuation surface (121) of the
adjacent cutting slot (12); and*

*a second surface (142) connected with the first surface (141) at a
common edge of the first surface (141) and the second surface (142),
wherein the second surface (142) and the arced cutting surface (122)
are arcuately formed in the acting portion (10) with respect to a
common line.*

Claim construction

6. Before considering the documents put forward in the request I will need to construe the claims of the patent, that is to say I must interpret it in the light of the description and drawings as instructed by Section 125(1) and take account of the Protocol to Article 69 of the EPC. In so doing, I am following the recent authority on claim construction in *Eli Lilly v Actavis* [2017] UKSC 48, which reminds me that I must also consider the extent to which equivalents to normal construction must be considered.
7. In their request, Appleyard Lees single out the terms, “parallel” and “common line” as being possible sources of ambiguity. Appleyard Lees note in respect of the term

“parallel” the judgement in *Catnic Components Ltd and another v Hill and Smith Limited* [1982] RPC 183, to suggest that the term parallel is not to take its literal meaning, but should allow for some variance beyond exactly parallel, so that the grooves be tilted and generally aligned such that drilling and tapping may occur, and the evacuation of chips generated is facilitated. The Patentee does not disagree with this interpretation, and nor do I.

8. In the observations, the Patentee appears to accept that there might be uncertainty about the meaning of the term “common line”, but suggests that it is used to mean an imaginary line that obliquely lies between the arced second surface (142) and the arced cutting surface (122).
9. The requester notes that outside of the claims (and of course the respective statement of invention) that the only mention of the term common line is at the end of paragraph 20 which reads:

With reference to Figs. 7 and 8, the fourth embodiment of a self-tapping screw in accordance with the present invention is similar to the aforementioned embodiments shown in Figs. 1 to 5 except further having a first evacuation slot 14. The first evacuation slot 14 is formed in the acting portion 10, is tilted relative to the center axis 4 of the shank 1, upwardly extends toward the head 2, and has a first surface 141 and a second surface 142. The first surface 141 is tilted relative to the center axis 4 of the shank 1 and is parallel to the chip evacuation surface 121 of the cutting slot 12. The arced second surface 142 is connected with the first surface 141 at a common edge thereof of the second surface 142 and the first surface 141. The second surface (142) and the arced cutting surface (122) are arcuately formed in the acting portion (10) with respect to a common line.

10. It is therefore clear that the reader is left to imagine this common line in the figures, and therefore to draw upon his understanding of the significance of these words in this context.
11. Whilst the dictionary definition of arcuate suggests that it means that it is curved or bow shaped, I note that in some arts the term arcuate carries an additional connotation of being concave or convex. The requester suggests that in the application there is no discussion of a particular technical effect associated with the arrangement of these surfaces on a common line. The requester therefore suggests that the skilled person would understand from the context that the “common line” does not require that the surfaces are joined, continuous or the like, and indeed such an arrangement is not shown. The requester therefore suggests that the term should be broadly interpreted.
12. The Patentee goes on in their observations to say that the arced second surface and the arced cutting surface are symmetrically and oppositely formed about the common line in figure 8. This is true of figure 8, but I note that as currently numbered, this arrangement is reversed in figures 10-13, 16-18 and 20, with the arced cutting surface being labelled effectively in reverse (121 and 122 are in effect mirrored). I also note that the claim does not go on to make such a definition of being symmetrically and oppositely formed. However, there is a reference in the

description in paragraph 11 which reads:

Preferably, the acting portion further has a first evacuation slot obliquely formed in the acting portion, upwardly extending toward the head and has a first surface and a second surface. The first surface is tilted relative to the center axis of the shank and is parallel to the chip evacuation surface of the adjacent cutting slot. The second surface is connected with the first surface at a common edge of the first surface and the second surface and is oppositely deflected relative to the arced cutting surface of the cutting slot.

13. It therefore seems to me that this suggests that the description of the Patent as granted envisages this opposite nature as being a preferred and therefore not essential feature. It might therefore be entirely consistent with the description for the common line to fall between the two slots, such that the slots each have concave (or indeed convex) surfaces with respect to that axis, that is to say that they have mirror or rotational symmetry. Alternatively, if the common line were to be somewhere outside of the screw, then the two surfaces could be concave (or indeed convex), and have translational symmetry.
14. However, there is of course the question of what the function of these slots. As the requester notes in respect of one of the citations, the purpose of such slots are so that the normal chip flow is appropriately directed. The requester's contention in the request is I think that this might be common general knowledge, which of course suits their argument in terms of combining documents using the Pozolli approach. However, I also note the observer's comment that the self-tapping screw is a product of long term developed techniques and that minor structural changes to the cutting slots on the screws, different effects and purposes can be achieved. I am not therefore convinced that there is a clearly set out argument based on what I have in front of me that the skilled person would be bound to reject the idea that the patent might envisage both opposite and translational symmetrical arrangements.
15. There is one further term in the claim, which although passed over in the observations, is identified as a possible difference with the prior art, which I should also briefly mention. In the claim the first surface of the evacuation slot is defined as being parallel to the adjacent cutting slot's chip evacuation surface. The scope of this word adjacent is not discussed in the observations or the request. The dictionary suggests amongst a range of definitions such as being "not distant" or "close", two potentially conflicting definitions. First, an item being on an "adjacent" (or facing) page and secondly as being adjacent in terms of sharing a common border or point. In this context, it is clear from the figures that the slots do not share a common border, so the term adjacent must be construed more broadly than that. Nonetheless, it implies that the slots are neighbouring and have a degree of closeness in this context.
16. I should also in passing mention, given the observer has suggested that the numbers shown in figures may not be correct, that under UK practice, the reference numerals included in the claim do not affect the scope of the claim – in general nor in this case.

The relevant documents

17. The request identifies 7 documents which may be relevant to the Patent. However, the final four of these documents are included in order to challenge additional features provided for in the dependent claims. The third document is used as a possible fall back, and I shall return to this briefly later. That means that TW 388464 and US3780389 are the most relevant documents to this opinion. Both relate to self-tapping screws, and pre-date the Patent.
18. TW 388464, D1, provides a self-tapping screw with two tilted slots, which are provided in the acting portion of the screw. As shown in the figure below, from TW388464 (figure 2), some of the similarities with the Patent can be clearly seen, in terms of the use of two slots, though in the figures the position of these slots in the figures is quite different.

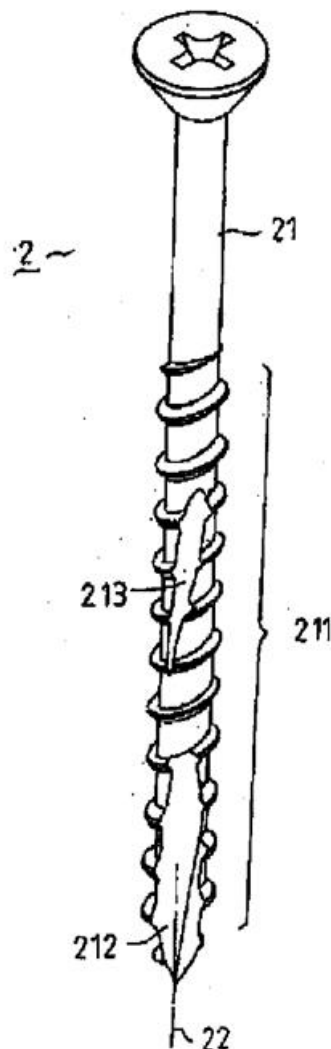

19. Figures 14 and 15 of US 3780389, D2, emphasise the nature of the slots in influencing chip flow. The description suggests that this results in enhanced chip handling and breaking characteristics, the curved flute side including the cutting edge is sufficiently curved to redirect the normal chip flow and thereby fragment the

chips by texture. I shall of course consider in more detail the similarities and differences between these documents and the Patent when I turn to inventive step.

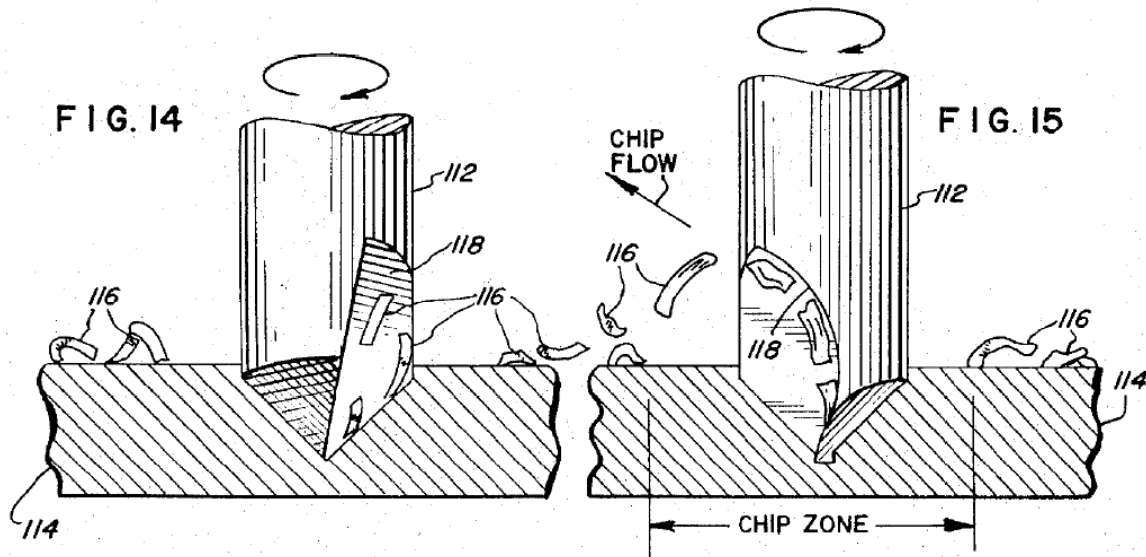

Inventive Step

20. The requester makes two parallel arguments on the question of inventive step using both the Pozzoli approach and the collocation approach drawn from SABAF v MFI [2002] EWCA Civ 976.
21. I shall first address the question of collocation. For a collocation argument to succeed, I must decide that there is no synergy between the arced nature of the evacuation slot and the cutting slot. I can see the attractiveness of the argument in terms of the apparent analogy in terms of the facts of the SABAF case. SABAF of course related to two parts of the flow of gas, in taking air above the hob and the use of the radial Venturi but importantly in that case they had no effect on each other. In the request there is no real argument that the same situation can be said to occur here. It seems to me that the purpose of the evacuation and cutting slots is to manage the flow of chips, which might otherwise cause clogging, or in some other way reduce the effectiveness of the self-tapping screw. It therefore seems to me that there will be synergy between the two slots. That is to say an undesirable flow in either might lead to clogging of the flow of the other and therefore the screw as a whole. It therefore seems to me that an argument that documents can be combined in a collocation fails.
22. I therefore turn to the arguments based on the principles established in Pozzoli SPA v BDMO SA [2007] EWCA Civ 588:
 - (1)(a) Identify the notional "person skilled in the art";
23. Here there is agreement between the two parties that the skilled person is someone involved in the design of self-tapping screws, and that this is a well-developed field, in which the use of various different designs using arced and straight slots are available widely.

(1)(b) identify the relevant common general knowledge of that person;

24. The requester suggests that the use of arcuate surfaces amounts to common general knowledge, in part relying on D2. The observations do not specifically concede this point, but do suggest that this is a well-developed field, a point I will return to shortly. It is not therefore clear to me that I can take D2 on its own as being common general knowledge.
25. However, I also note that the requester suggests that the patent itself suggests that the use of arcuate surfaces are known, which is true, in so far as it notes two arrangements of screws are conventional. Following the hearing decision in NEC O/038/00 (and specifically paragraph 19), the word conventional is taken by the Manual of Patent Practice to mean common general knowledge. However, I think that looking at paragraphs 2-6, I must take some care. It may well be that the specific arrangements envisaged in those paragraphs and that in EP0997651 A1 are common general knowledge. However, it is not clear to me that there is some general teaching that arcuate surfaces are advantageous in terms of chip flow, in those paragraphs, nor in EP0997651. This is an important point, which I shall return to shortly.

(2) identify the inventive concept of the claim in question or if that cannot readily be done, construe it;

26. There is agreement that the inventive concept relates to the use of this evacuation slot with an arcuate form alongside an arced cutting surface, and a cutting slot with an arced cutting surface. The claim also specifies that the arced cutting surface of the cutting slots from a V-shaped section, and a blade portion intersects with the periphery of the shank and the threaded portion of the self-tapping screw, and that the evacuation slot is tilted relative to the centre access of the shank and parallel to the chip evacuation surface of the adjacent cutting surface. The claim further requires that the first surface of the evacuation slot is tilted relative to the centre axis of the shank and parallels to the chip evacuation surface of the adjacent cutting slot and a second surface connected at a common edge of the first surface, where the second surface is arcuately formed in the acting portion with respect to a common line.

(3) identify what, if any, differences exist between the matters cited as forming part of the "state of the art" and the inventive concept of the claim or the claim as construed;

27. Again there is agreement between the requester and the observer as to the main difference between D1 and the claimed invention. This relates to the cutting surface of the profile groove [the evacuation slot] (and the groove [the cutting slot]) which are planar, rather than arcuate.
28. In the observations, I note also the requester suggest D1 a) does not provide for one of the wall surfaces of the profile groove to be parallel to one of the wall surfaces of the other groove, and b) that in figure 2, they are not adjacent.
29. On a), in the request Appleyard Lees suggest that the arrangements in the figures are tilted and "generally aligned." As I have already concluded that the term parallel

should be construed with some breadth, it seems to me, at least arguable that these could fall within that definition.

30. On point b) the request does not suggest that this is a difference, but equally does not specifically mention this feature in its comparison with D1. In contrast the observations suggest that in this figure that they are spaced apart, and this is sufficient in the observers view that it should not be deemed to be adjacent. In the observations, it is asserted that the gap is sufficient that the blade portion formed by the profile groove will not drill and tap at the same time. Of course, in the selected figure (which the observations zoom in on and I repeat here), the bottom of the top slot 213 appears to me to be separated by a single turn of the thread from the bottom slot – that is to say that they are on opposite sides of this particular turn of the thread.

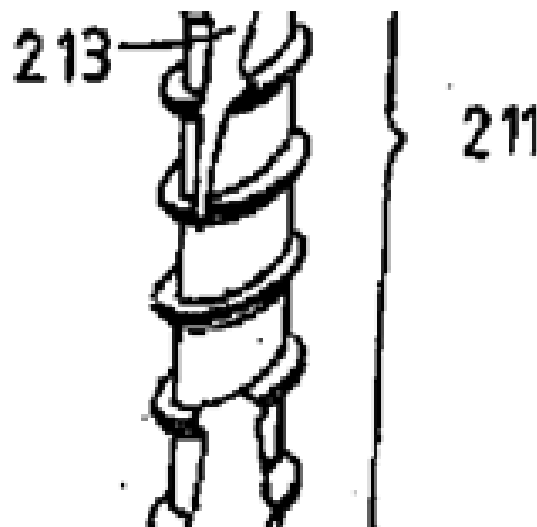

31. However, ultimately, for the reasons that I set out below, I am not convinced that I need to consider these possible differences a) and b) further.

(4) Viewed without any knowledge of the alleged invention as claimed, determine whether those differences constitute steps which would have been obvious to the person skilled in the art.

32. The fourth step, and the question of whether this alteration to D1 would be obvious to the skilled person, is intrinsically linked to the question of what the common general knowledge might be. That is to say whether it is clear that the common general knowledge includes the use of such arcuate surfaces and whether the skilled person would incorporate this feature. In the request and the observations, there is not a great deal to help me. In the request, the requester suggests that the skilled person faced with D1 and further faced with the task of further improving the drilling efficiency of this document would look to D2 and therefore be lead to the current invention. This problem solution approach is not the approach taken in Pozolli, which is the relevant UK case law here. In contrast, the observer suggests that the skilled person would know that this is a well-developed field, and that further structural designs for improving the self-tapping screw are limited.
33. The request and the observations make no comment on the likely approach of the skilled person, for example commenting on the skilled person's expectation of

success in modifying the design and the effort involved in that, against the motivation simply to adopt an alternative existing option. Again here, there is no real evidence or argument in the request or the observations about what might be lying in the road, or the extent to which there was a long standing technical problem for example in the ability to have self-tapping screws for particular materials.

34. It is not clear from the information provided that the skilled person could be expected to see the effort of designing and researching a new screw would be required and that he has a significant chance of success in those efforts. Nor is it clear as I concluded above in paragraph 25 that the common general knowledge means that the use of arcuate surfaces is known to improve performance of any such slot, and that this should therefore simply be adopted.
35. Before I conclude, however, the request does make two further points. The request suggests that the teaching of D2 suggests that the fastener concerned has enhanced chip handling and chip breaking characteristics, and therefore provides greater drilling efficiency. The request suggests that as this is drawn from the same field as D1 (another self-tapping screw) that in effect the two documents can be mosaicked together, such that the features of D2 would be applied to D1. Again here, I must exercise some caution, as it was concluded in Dow Chemical Company (Mildner's Patent), [1973] RPC 804 that I must consider the extent to which I can conclude that the documents are ones which the seeker after information would come across and would consider together. This point is not addressed in the request or observations, but there is no clear pointer from one document to the other, and I am also mindful of the point made in the observations that this is a well-developed field, with many different designs of self-tapping screw being available. I do not therefore believe that this mosaic argument is sufficient.
36. Finally, there is the question of TWM373414U, D3, which discloses an arrangement in which U-shaped cuts are provided in the thread portion. One such arrangement is shown in figure 7.

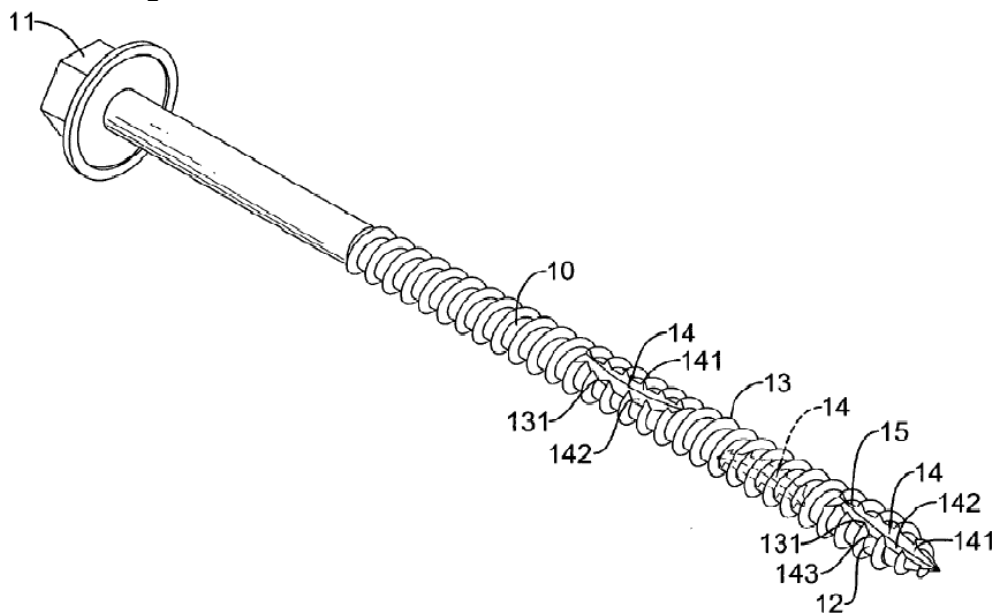

37. In the observations, this document is used to bolster an argument against a literal

interpretation of the word parallel. However, I should also say that having looked at this document in full, there is nothing further provided here that addresses the question of the common general knowledge and arcuate slots. The observations also note that this document does not provide for tilting of these slots, and suggests that they are also not adjacent.

38. I am therefore ultimately drawn to the argument made in the observations, that this is a well-established field, and there is no clear argument using case law of why the skilled person should adopt this particular adaptation, to provide arcuate slots.
39. I am therefore not convinced, based on the evidence provided that it would be obvious for a skilled person to adapt the screw of D1 in a way that would result in the self-tapping screw as defined in claim 1.
40. Having come to that conclusion, then the additional documents, which relate to further features listed in the dependent claims and the arguments relating to them fall away.

Opinion

41. It is therefore my opinion that EP2385261 is inventive, with respect to the citations raised in this request.

Robert Shorthouse
Examiner

NOTE

This opinion is not based on the outcome of fully litigated proceedings. Rather, it is based on whatever material the persons requesting the opinion and filing observations have chosen to put before the Office.