

Geological Disposal Generic Transport System Design

December 2016



Geological Disposal

Generic Transport System Design

December 2016

Conditions of Publication

This report is made available under the Radioactive Waste Management (RWM) Transparency Policy. In line with this policy, RWM is seeking to make information on its activities readily available, and to enable interested parties to have access to and influence on its future programmes. The report may be freely used for non-commercial purposes. RWM is a wholly owned subsidiary of the Nuclear Decommissioning Authority (NDA), accordingly all commercial uses, including copying and re publication, require permission from the NDA. All copyright, database rights and other intellectual property rights reside with the NDA.

Applications for permission to use the report commercially should be made to the NDA Information Manager.

Although great care has been taken to ensure the accuracy and completeness of the information contained in this publication, the NDA cannot assume any responsibility for consequences that may arise from its use by other parties.

© Nuclear Decommissioning Authority 2016 All rights reserved.

ISBN 978-1-84029-558-0

Other Publications

If you would like to see other reports available from RWM, a complete listing can be viewed at our website <https://rwm.nda.gov.uk>, or please write to us at the address below.

Feedback

Readers are invited to provide feedback on this report and on the means of improving the range of reports published. Feedback should be addressed to:

RWM Feedback
Radioactive Waste Management Limited
Building 587
Curie Avenue
Harwell Campus
Didcot
OX11 0RH
UK

email: rwmfeedback@nda.gov.uk

Preface

Radioactive Waste Management Limited (RWM) has been established as the delivery organisation responsible for the implementation of a safe, sustainable and publicly acceptable programme for the geological disposal of the higher activity radioactive wastes in the UK. As a pioneer of nuclear technology, the UK has accumulated a legacy of higher activity wastes and material from electricity generation, defence activities and other industrial, medical and research activities. Most of this radioactive waste has already arisen and is being stored on an interim basis at nuclear sites across the UK. More will arise in the future from the continued operation and decommissioning of existing facilities and the operation and subsequent decommissioning of future nuclear power stations.

Geological disposal is the UK Government's policy for higher activity radioactive wastes. The principle of geological disposal is to isolate these wastes deep underground inside a suitable rock formation, to ensure that no harmful quantities of radioactivity will reach the surface environment. To achieve this, the wastes will be placed in an engineered underground facility – a geological disposal facility (GDF). The facility design will be based on a multi-barrier concept where natural and man-made barriers work together to isolate and contain the radioactive wastes.

To identify potentially suitable sites where a GDF could be located, the Government has developed a consent-based approach based on working with interested communities that are willing to participate in the siting process. The siting process is on-going and no site has yet been identified for a GDF.

Prior to site identification, RWM is undertaking preparatory studies which consider a number of generic geological host environments and a range of illustrative disposal concepts. As part of this work, RWM maintains a generic Disposal System Safety Case (DSSC). The generic DSSC is an integrated suite of documents which together give confidence that geological disposal can be implemented safely in the UK.

Executive Summary

RWM has been established as the delivery organisation responsible for the implementation of a safe, sustainable and publicly acceptable programme for geological disposal of the UK's higher activity wastes. Information on the UK Government's approach to geological disposal, coupled with safe and secure interim storage, in the long-term management of higher activity waste is given in an overview document (the Overview).

The geological disposal facility (GDF) will be a highly-engineered facility, located deep underground, where radioactive waste will be isolated within multiple engineered and natural protective barriers capable of preventing the release of harmful quantities of radioactivity to the surface environment. In order to identify potential sites where the GDF can be located, the UK Government is developing a consent-based approach based on working with communities that are willing to participate in the siting process. Development of the siting process is ongoing and no site has yet been identified for the GDF.

This document is the Generic Transport System Designs report and is one of two volumes that make up the Generic Design (the other being the Generic Disposal Facility Designs report). This document has been developed as part of a suite of documents that together form the generic Disposal System Safety Case (DSSC), and is intended to provide information to a wide range of interested parties of the work that RWM has undertaken on the development of a number of illustrative designs for geological disposal in the UK. It also provides the basis for safety assessments which underpin the generic DSSC.

The generic transport system is designed to use any combination of rail and road transport and concepts for suitable rail and road vehicles are described. The use of sea or inland waterways can be addressed at a future date when potential GDF sites have been identified. This report describes both the requirements and potential logistics associated with the transport operation based on road or rail scenarios.

Waste will need to be transported safely from the site of production or interim storage to the GDF, and this report describes the design of the transport system for that purpose. As candidate sites for the GDF have not been identified, development of a transport system must at this stage remain generic and this report considers transport to a range of notional locations through England and Wales. This report describes the transport packages which will be used to safely transport radioactive waste to the GDF. It also describes the operations required at waste producers' sites, to ensure safe and efficient transport of transport packages through the public domain.

In addition to the more specialist transport of the radioactive waste to the GDF this report also considers the transport of construction materials, spoil and personnel associated with building and operating the GDF. The transport system design described in this report supports assessment of environmental, social and economic impacts. This report is a forerunner to a Transport Assessment and provides information for stakeholders on the likely nature and scope of transport activities associated with building and operating the GDF and provides some information on how the impacts of those activities will be minimised or mitigated.

As the siting process progresses, there will also be a requirement to maintain and periodically update the generic designs and this report to take account of future requirements and to support both wider stakeholder engagement and the waste packaging assessment process.

List of Contents

Conditions of Publication	ii
Other Publications	ii
Feedback	ii
Preface	iii
Executive Summary	v
List of Contents	vii
1 Introduction	1
1.1 The generic Disposal System Safety Case (DSSC)	1
1.2 Introduction to the Generic Transport System Designs (GTSD) report	3
1.3 Objective	3
1.4 Scope	4
1.5 Document structure	4
2 Transport System Design Development	5
2.1 Development of the generic designs	5
2.2 Iterative design process	5
2.3 Design reports and supporting documents	6
2.4 Assessment and mitigation of impacts of transport	7
2.5 Integrating safety into the design	8
2.6 Assessment of waste packages	8
2.7 Transport packages	9
2.8 Dispatch and receipt of transport packages	9
3 Transport Infrastructure	11
3.1 General requirements	11
3.2 Environment and sustainability	11
3.3 Location of radioactive wastes	11
3.4 Location of the GDF	12
3.5 Mode of transport	13
3.6 Waste types and transport rates	17
4 Radioactive Waste and Transport Packages	19
4.1 Transport arrangements	19
4.2 Waste packages that are transport packages	19
4.3 Waste packages that will be overpacked for transport	21

4.4	Summary	24
5	Materials and Personnel Transport	27
5.1	Introduction	27
5.2	Construction material	27
5.3	Excavation of spoil	29
5.4	Storage of excavated material on-site	30
5.5	Personnel	30
6	Transport Conveyances	33
6.1	Rail wagons	33
6.2	Road vehicles	35
6.3	Construction and spoil vehicles	38
7	Transport System Management	43
7.1	Introduction	43
7.2	Operational management	44
7.3	Waste consignor transport operations	45
7.4	GDF transport infrastructure and operations	47
8	Safety, Security and Safeguards	53
8.1	Safety requirements	53
8.2	Security	53
8.3	Safeguards	54
8.4	Emergency arrangements	54
9	Implications of a Change to the 2013 Derived Inventory	57
9.1	GDF transport movements	57
9.2	Additional facilities	57
9.3	Other factors	58
10	Way Forward	59
	References	61
	Glossary	65
	Appendix A – Waste volumes for disposal	67
	Appendix B – Waste package numbers	69
	Appendix C – Materials and Personnel Transport Movements	73
	Appendix D – Transport Conveyance Dimensioned Drawings	76

1 Introduction

1.1 The generic Disposal System Safety Case (DSSC)

RWM has been established as the delivery organisation responsible for the implementation of a safe, sustainable and publicly acceptable programme for geological disposal of the UK's higher activity radioactive waste. Information on the approach of the UK Government and devolved administrations of Wales and Northern Ireland¹ to implementing geological disposal, and RWM's role in the process, is included in an overview of the generic Disposal System Safety Case (the Overview) [1].

A geological disposal facility (GDF) will be a highly-engineered facility, located deep underground, where the waste will be isolated within a multi-barrier system of engineered and natural barriers designed to prevent the release of harmful quantities of radioactivity and non-radioactive contaminants to the surface environment. To identify potentially suitable sites where a GDF could be located, the Government is developing a consent-based approach based on working with interested communities that are willing to participate in the siting process [2]. Development of the siting process is ongoing and no site has yet been identified for a GDF.

In order to progress the programme for geological disposal while potential disposal sites are being sought, RWM has developed illustrative disposal concepts for three types of host rock. These host rocks are typical of those being considered in other countries, and have been chosen because they represent the range that may need to be addressed when developing a GDF in the UK. The host rocks considered are:

- higher strength rock, for example, granite
- lower strength sedimentary rock, for example, clay
- evaporite rock, for example, halite

The inventory for disposal in the GDF is defined in the Government White Paper on implementing geological disposal [2]. The inventory includes the higher activity radioactive wastes and nuclear materials that could, potentially, be declared as wastes in the future. For the purposes of developing disposal concepts, these wastes have been grouped as follows:

- High heat generating wastes (HHGW): that is, spent fuel from existing and future power stations and High Level Waste (HLW) from spent fuel reprocessing. High fissile activity wastes, that is, plutonium (Pu) and highly enriched uranium (HEU), are also included in this group. These have similar disposal requirements, even though they don't generate significant amounts of heat.
- Low heat generating wastes (LHGW): that is, Intermediate Level Waste (ILW) arising from the operation and decommissioning of reactors and other nuclear facilities, together with a small amount of Low Level Waste (LLW) unsuitable for near surface disposal, and stocks of depleted, natural and low-enriched uranium (DNLEU).

¹ Hereafter, references to Government mean the UK Government including the devolved administrations of Wales and Northern Ireland. Scottish Government policy is that the long term management of higher activity radioactive waste should be in near-surface facilities and that these should be located as near as possible to the site where the waste is produced.

RWM has developed six illustrative disposal concepts, comprising separate concepts for HHGW and LHGW for each of the three host rock types. Designs and safety assessments for the GDF are based on these illustrative disposal concepts.

High level information on the inventory for disposal, the illustrative disposal concepts and other aspects of the disposal system is collated in a technical background document (the Technical Background) [3] that supports this generic Disposal System Safety Case.

The generic Disposal System Safety Case (DSSC) plays a key role in the iterative development of a geological disposal system. This iterative development process starts with the identification of the requirements for the disposal system, from which a disposal system specification is developed. Designs, based on the illustrative disposal concepts, are developed to meet these requirements, which are then assessed for safety and environmental impacts. An ongoing programme of research and development informs these activities. Conclusions from the safety and environmental assessments identify where further research is needed, and these advances in understanding feed back into the disposal system specification and facility designs.

The generic DSSC provides a demonstration that geological disposal can be implemented safely. The generic DSSC also forms a benchmark against which RWM provides advice to waste producers on the packaging of wastes for disposal.

Document types that make up the generic DSSC are shown in Figure 1. The Overview provides a point of entry to the suite of DSSC documents and presents an overview of the safety arguments that support geological disposal. The safety cases present the safety arguments for the transportation of radioactive wastes to the GDF, for the operation of the facility, and for long-term safety following facility closure. The assessments support the safety cases and also address non-radiological, health and socio-economic considerations. The disposal system specification, design and knowledge base provide the basis for these assessments. Underpinning these documents is an extensive set of supporting references. A full list of the documents that make up the generic DSSC, together with details of the flow of information between them, is given in the Overview.

Figure 1 Structure of the generic DSSC

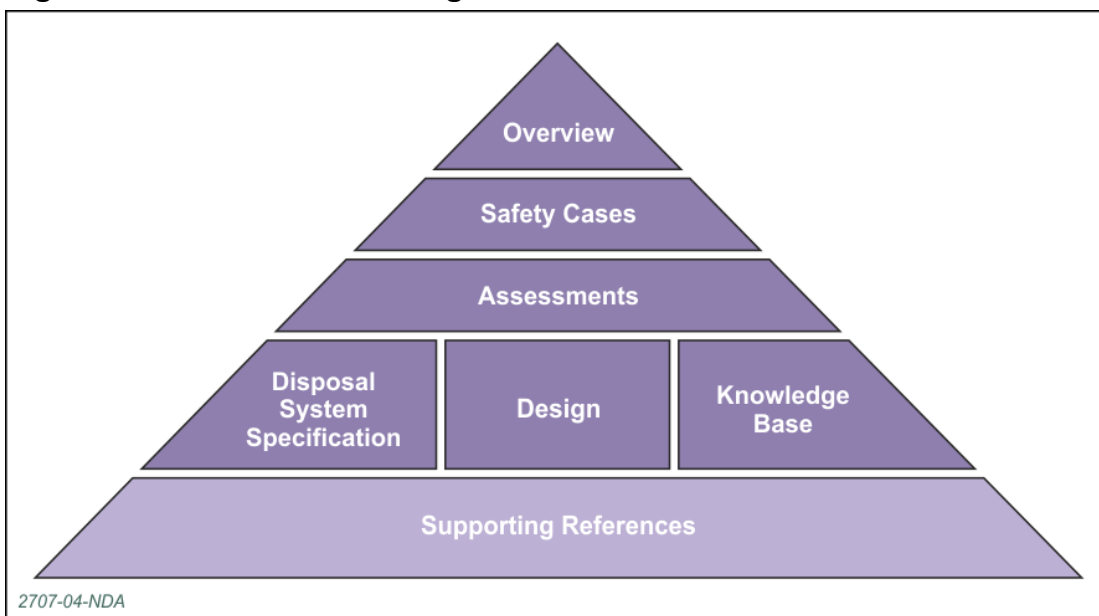

1.2 Introduction to the Generic Transport System Designs (GTSD) report

This document is the GTSD report and is one of two volumes that make up the Generic Design (the other being the Generic Disposal Facility Designs report).

The generic DSSC was previously published in 2010. There are now a number of drivers for updating the safety case as an entire suite of documents, most notably the availability of an updated inventory for disposal.

This document updates and replaces the 2010 GTSD report published as part of the 2010 generic DSSC suite. This issue includes the following improvements:

- it addresses transport of the 2013 Derived Inventory [4]
- it considers the transport of additional radioactive waste package types, the concrete drums, robust shielded waste packages and Transport and Disposal Container (TDC) for DNLEU
- it includes discussion of transport of construction materials, spoil and personnel is given greater prominence and has been expanded upon significantly

The transport system design defines what comprises the transport system and how the system will be operated. The transport system is divided into two main areas – the transport of construction materials, spoil and personnel associated with building and operating the GDF and the more specialist transport of the radioactive waste to the GDF. The radioactive waste transport system is national in scope. Its main objective is to deliver packaged waste to a facility. The transport system is designed to use any combination of rail or road transport. The use of inland waterways will be evaluated at a future date when potential GDF sites have been identified.

1.3 Objective

The objective of this report is to inform stakeholders of current ideas, and to provide a transport system description as a basis for the various safety assessments that make up the generic DSSC. It addresses both the transport of radioactive waste to the GDF and the transport of construction materials, spoil and personnel associated with building and operating the GDF.

The operational transport solutions outlined here are provided to give an appreciation of the transport system required for moving radioactive waste from waste storage sites and to help stakeholders to understand the potential work ahead. However, because the transport arrangements are based on provisional information, it is expected that changes will occur before transport to the GDF is expected to commence. It is therefore envisaged that these operational aspects will be reviewed on a regular basis.

This approach also provides a basis for developing waste package specifications, through informing the requirements to transport radioactive waste to the GDF. It is then possible to assess, using the established Disposability Assessment process², if waste packaging proposals from waste producers are consistent with the requirements currently foreseen for transport.

² The process by which assessments of waste-packaging proposals are undertaken and advice is provided to the waste-packaging site on the disposability of the proposed waste package, inclusive of the requirements for transport of a waste package to the GDF. In cases where the proposal will lead to a waste package compliant with GDF safety and environmental cases, this will be signified by the issue of a Letter of Compliance (LoC).

The description of the requirements for transport of construction materials, spoil and personnel associated with building and operating the GDF informs stakeholders of the type and scale of transport operations that will take place in support of the GDF. This report also provides information on the need for transport assessment and a management strategy to mitigate the impacts of the transport associated with building and operating the GDF when developing the GDF for a specific site.

1.4 Scope

The generic design for the GDF is described in the following two reports:

- This document, the GTSD report, describes the operations required to ensure safe and efficient transport of waste packages, construction materials, spoil and personnel through the public domain to the GDF. The report describes both the requirements and potential logistics associated with the transport operation based on road or rail scenarios
- The Generic Disposal Facility Design (GDFD) [5] report describes the processes of waste package receipt, handling and emplacement and the design characteristics that a disposal facility will need to include for the inventory for disposal. The report provides information on what a facility could look like and identifies the different packaging and disposal processes for different types of waste

These reports are intended to provide information to a wide range of interested parties on the work undertaken to develop illustrative designs for geological disposal in the UK. The designs have been developed drawing on work done both in the UK and in international programmes in a number of different geological environments and aligned with the requirements specified in the Disposal System Specification (DSS).

The transport system design is based on technology that is available today and existing operational practice in the transport of radioactive materials in the UK. It is expected that the system design will evolve to suit both waste packaging solutions and transport solutions as they become more mature. This approach has been adopted to provide a generic transport design which can be used in the associated assessments of safety, environmental, social and economic impacts, whilst keeping open a broad choice of disposal concept options. As the GDF siting process progresses, details of a geological environment and site-specific characteristics will become available, which will allow transport designs to be developed in more detail.

1.5 Document structure

This report describes a generic transport system for the GDF. Section 2 identifies the design process and how safety requirements are integrated into the design. The transport of radioactive wastes is described in Section 3. The transport packages and transport conveyances are described in Sections 4 and 5. Section 6 discusses the transport of construction materials, excavated spoil and personnel that will be need to be transported to and from the GDF. The management of the transport system is discussed in Section 7 and the safety, security and safeguards³ requirements in Section 8. The implications of adopting a different inventory for disposal scenario on the GTSD are discussed in Section 9. The report is concluded in Section 10 which describes the way forward and how the design is expected to evolve over time.

³ Safeguards are the measures to verify that countries comply with their international obligations not to use nuclear materials from their civil nuclear programmes to manufacture nuclear weapons.

2 Transport System Design Development

2.1 Development of the generic designs

The generic transport system design presented in this report is currently being used to:

- further develop the understanding of the functional and technical requirements of the disposal system
- further develop the understanding of the design requirements
- support the scoping and assessment of the safety, environmental, social and economic impacts of the GDF
- support development and prioritisation of RWM's R&D programme
- underpin the analysis of the potential cost of geological disposal
- support assessment of the disposability of waste packages proposed by waste owners

At the current stage of the programme, work is focused on analysing and developing a generic transport system. In the future, this transport system design will be tailored to the specific location of the GDF and also constraints resulting from the siting process.

2.2 Iterative design process

RWM has developed a generic DSS which describes the requirements on the disposal system and provides the starting point for design and assessment work. The DSS comprises two documents:

- the Disposal System Specification Part A – High Level Requirements (DSS Part A) [6], which describes the high-level requirements on the disposal system and is in a form suitable for a wide range of stakeholders
- the Disposal System Specification Part B – Technical Specification (DSS Part B) [7], which describes in more detail the requirements on the disposal systems, together with a justification for each requirement

The illustrative designs have been developed to be consistent with the requirements defined in the DSS Part A. These documents currently describe generic requirements, reflecting the fact that a site and a disposal concept have yet to be selected. They will be periodically updated throughout the implementation of the GDF programme, for example to respond to changes in regulations and to respond to issues identified from undertaking safety assessments. The DSS Part A, in particular, will evolve from generic to site-specific requirements as site-specific information becomes available.

Figure 2 gives an overview of the process by which the DSS incorporates external sources of information to guide the design and assessment processes, which in turn leads to refinements and changes in the DSS. Since this figure represents a high-level illustration of the process, to avoid making the figure over-complicated feedback loops have not been explicitly represented. Nevertheless, this figure clearly identifies the main constraints on and outputs from the design process.

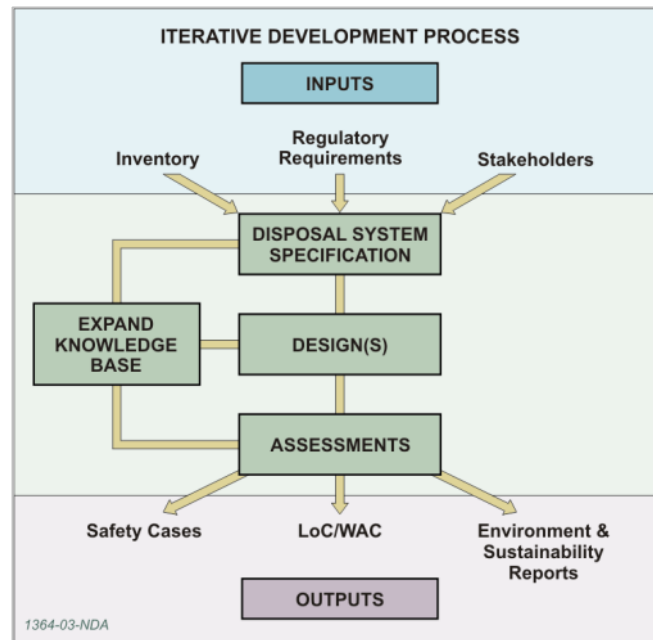
Figure 2 Iterative disposal system development

The use of illustrative designs and safety assessments of these designs allows RWM to challenge and identify potential improvements to these designs and allows appropriate disposal solutions for different waste types to be addressed and identify further research and development tasks.

The iterative process described in Figure 2 will continue as development of the design and safety case continues. There will be hold points throughout this process when regulators will be required to assess the safety case and agree or give consent to commence the next stage (for example, construction, commissioning, operation, decommissioning, closure). Safety Functional Requirements will be used to provide the formal, auditable link between the safety assessment work and the design. Requirements will be developed in terms of design functionality so that designers have the freedom to provide the most appropriate way to implement the required functions. In the future, this will be integrated into a formal requirements management system that is likely to include a constraints set in order clearly articulate and agree the requirements and enable their delivery.

2.3 Design reports and supporting documents

As described in Section 1, the generic illustrative design for the GDF is described in two reports: the GDFD report and this document, the GTSD report. These reports present an overview of what a facility and the transport system could look like. The data that supports the designs presented in these reports are provided in the Data Report [8]. These reports are supported by a number of other documents:

- **Design Status Report** – This document records the rationale behind the key historical design developments to date and the overview of the engineering design work [9]. This status report will be periodically updated to include design enhancements that are adopted, in order to support any future design development work and to provide reference to the underpinning source information.
- **Engineering Design Manual** – The Engineering Design Manual is the part of RWM's management system which describes the engineering design process that will be followed to establish, maintain and update the engineering designs that will be used for the development, construction, commissioning, operation, closure and decommissioning of the GDF. This manual provides users of the engineering

design process with an overview of the requirements, expectations, steps and tools to work with confidence and compliance, to know how to obtain the detailed operational documentation, and understand how that fits with the wider arrangements.

- **Science and Technology Plan** – In order to prioritise the R&D programme, RWM has developed a ‘Science and Technology Plan’ [10] which presents a plan to deliver future generic research and development activities. Generic is defined as those activities that can be undertaken without specific knowledge of the eventual host site for the GDF. The plan provides opportunities for dialogue and involvement of interested parties and stakeholders in the development of RWM’s knowledge base for the safe geological disposal of radioactive waste. This document identifies areas in the GDF design where additional work is required to expand RWM’s knowledge base.

Since publication of the 2010 generic DSSC, the GDF and transport system designs have been developed to address identified issues and enhance aspects of the designs. One aspect of this work programme has been the adoption of Building Information Modelling (BIM) and the development of GDF designs in a 3D design environment. The use of BIM is part of the Government Construction Strategy [11], which requires the whole project lifecycle, including the design, to be conducted in a BIM environment.

This approach is outlined in [12] and sets out the process for RWM to be compliant with the Government’s requirement that all public sector construction projects are delivered in a BIM environment by 2016.

2.4 Assessment and mitigation of impacts of transport

Under the provisions of the Development Management Procedure [13] and the Infrastructure Planning Regulations [14], a Transport Assessment will be required to support a planning application owing to the potentially significant transport implications of the GDF. The National Planning Policy Framework [15] also notes that ‘all developments that generate significant amounts of movement’ should be supported by a Transport Statement or Transport Assessment’.

The scope of a Transport Assessment for the GDF will take account of relevant national and local policies and guidance documents to the extent that they are relevant to the assessment of the GDF.

A Transport Assessment will assess the transport implications of all transport activities associated with the GDF and to ensure compatibility with national and local transport strategies and plans. Typical objectives of a Transport Assessment are: to reduce the need to travel; to promote accessibility by all transport modes; to provide accurate analyses of the impact of residual transport operations and hence to minimise the need for changes to the transport infrastructure. One aspect of a Transport Assessment will be mitigating the residual transport impacts. A key mitigation measure, which is consistent with the objectives of a Transport Assessment and is in keeping with the Nuclear Decommissioning Authority (NDA) Transport Strategy, is likely to be to minimise the transport operation.

A Transport Assessment will be developed once a potential site is identified. The Transport Assessment will iteratively interact with and inform the transport system design development for the GDF.

At the generic stage whilst the location of the GDF is unknown, there is a relatively high degree of uncertainty in the transport impacts of the GDF and a Transport Assessment cannot meaningfully be undertaken. This report is a forerunner to a Transport Assessment and provides information for stakeholders on the likely nature and scope of transport

activities associated with building and operating the GDF and provides some information on how the impacts of those activities will be minimised or mitigated.

The transport system design shall ensure that disruptions to parts of the transport network, and interruptions or delays to the planned conditioning and packaging of wastes at any one site can be accommodated. The transport system design shall also incorporate contingencies that allow for changes to the availability of the GDF including:

- interruptions to operations at the GDF
- disruptions to parts of the transport network (it should be possible to re-route waste packages, use alternative means of transport, or change the scheduling of waste consignments from different sites if part of the transport network is disrupted)
- interruptions to the conditioning and packaging of wastes at waste-producing sites (it should be possible to change the scheduling of waste consignments from different sites)

2.5 Integrating safety into the design

The illustrative designs take account of the safety of radioactive waste transport, the safety of the construction and operation of the GDF and the safety of a disposal facility in the very long term, after it has been sealed and closed. More detail on the safety of radioactive waste transport can be found in the generic Transport Safety Case main report [16].

This report provides the basis of assessment of the radiological safety of waste transport to the GDF in order to provide confidence that a design that is compliant with relevant regulatory requirements is achievable.

The generic transport system designs have been updated to reflect the 2013 Derived Inventory and to incorporate other changes identified for implementation, endorsed by the RWM Change Control process, to further improve and enhance the designs. Consideration has also been given to addressing comments made by regulators and other organisations that can be addressed at this early generic stage. Additionally, reference has been made to a number of documents published prior to and since the 2010 report [17] that make specific recommendations regarding the designs.

All rail and road links to the GDF, and on the GDF site, will comply with RWM safety, environmental, security and safeguards principles for the design process. Fundamental principles relating to transport are that:

- the safety of waste transport shall be demonstrated through a comprehensive and systematic process of safety and environmental assessment
- waste transport shall comply with all relevant safety and environmental protection legislation
- the environmental detriment from waste transport shall be minimised so far as is reasonably practicable

2.6 Assessment of waste packages

The quality of the waste packages is essential to transport safety. At present, to ensure compliance with the DSS, generic waste package specifications [18, 19, 20] have been developed to specify the requirements for the waste packages. Assessment of a packaging proposal is undertaken as part of the Disposability Assessment process against the requirements of these specifications. The Disposability Assessment process gives the waste producer confidence that the waste package has been assessed by an independent waste management organisation in accordance with procedures that are scrutinised by the

regulators and has been found to be compliant with the concept for geological disposal as presently understood. This does not remove the need for further assessment of the waste package against future waste acceptance criteria but, the provision of a final-stage Disposability Assessment is an essential component of the package record. Further information on the Disposability Assessment process is available [21].

2.7 Transport packages

The transport system for radioactive waste includes all of the processes, equipment and management arrangements required for the movement of waste packages from a waste-producing site to the GDF including, for example, loading of transport packages onto vehicles, monitoring of transport packages and vehicles during transit as well as changes in transport mode.

The most hazardous materials, including HHGW and some types of LHGW, are planned to be transported in large reusable transport containers made from high-integrity materials that provide containment of radioactive materials and shielding from radiation even under transport accident conditions (severe impact and fire). Less hazardous LHGW is assumed to be packaged in 'industrial packages'; typically large steel or concrete boxes which are designed to be both a transport and disposal package.

At this stage, designs have been developed for two types of re-usable transport containers to transport waste to the GDF. The first is a family of Standard Waste Transport Container (SWTC) designs which will be used to transport the more hazardous LHGW packages. The second is a Disposal Container Transport Container (DCTC) design, which will be used for the transport of HHGW.

The safety of the packages is provided by a combination of the design and by the regulatory limitation of the quantity and form of the radioactive material that can be carried in the respective transport containers.

2.8 Dispatch and receipt of transport packages

Radioactive waste transport packages will be dispatched to the GDF according to an agreed receipt programme, to meet the needs of the GDF operational programme and of waste owners. Under currently established arrangements, prior to any waste packages being dispatched to the GDF, a rigorous system of checking and monitoring of each transport package will be carried out by the consigning organisation (the waste owner or the organisation acting on behalf of the waste owner) [22]. This will ensure, in particular, that the specific identification of individual waste packages in terms of the nature and quantity of waste is confirmed and that the package complies with the waste acceptance criteria that will be established for receiving waste at a disposal facility.

The approach to ensuring the security and for emergency response to incidents in the transport of radioactive waste transport packages are set out in Sections 8.2 and 8.4, respectively.

Following receipt of packages at the GDF, administrative checks of the consignment, physical inspection of the transport package, and radiological measurements of surface dose and contamination will be carried out. This will confirm that no damage had been sustained in transport and act as a cross-check on the inspection carried out at the point of dispatch. Facilities will also be available for handling any packages that do not meet acceptance criteria.

3 Transport Infrastructure

3.1 General requirements

RWM has designed the generic transport system to use a combination of rail and road transport, and has developed concepts for suitable rail and road vehicles.

Sea transport has been considered, but less detail is provided as this will only be applicable to specific site locations. The use of inland waterways will similarly be assessed at a future date when such a study is likely to be meaningful. The reason for this is that the network of waterways that are wide enough is not extensive, so their usefulness will be site-specific. The use of air transport is considered to be impractical.

3.2 Environment and sustainability

Careful attention to the design of the transport system, selection of the most appropriate transport modes, transport routes and sympathetic infrastructure development will all serve to minimise any potential adverse environmental effect and, at the same time, will result in a transport system which can be operated in a safe and efficient manner. The transport operations associated with the GDF include the transport of radioactive waste, construction materials and equipment, excavated spoil, personnel and visitors.

Rail is assumed to be the primary means for importing bulk construction materials and most radioactive waste packages and for the export of any excess rock spoil. A rail station has also been included in the generic surface layout to allow for the possibility of workers commuting by rail, although the viability of a passenger rail system has yet to be assessed in light of the assumed number of workers regularly travelling to and from the GDF.

3.3 Location of radioactive wastes

The transport system design is generic, as candidate sites for the GDF have not been identified. There are 24 sites across the UK where the radioactive wastes in the inventory for disposal are anticipated to be stored awaiting disposal. These are presented in Figure 3.

Figure 3 Sites where higher activity radioactive waste and materials are anticipated to be stored

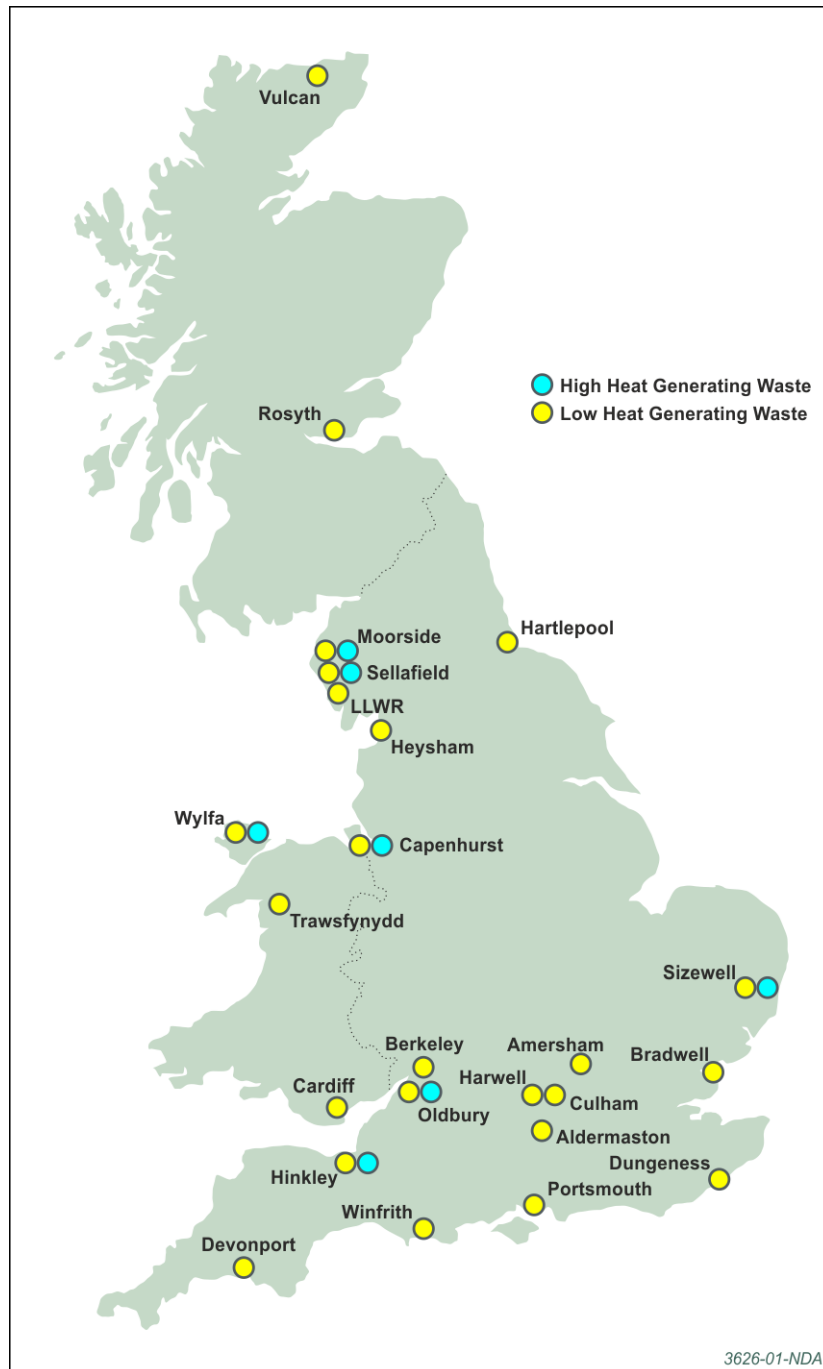

3.4 Location of the GDF

It is Government policy to dispose of the UK's higher activity waste in the GDF. Scottish Government policy is that higher activity waste should be stored in near-surface facilities near to the sites where the waste is produced. Assessments of the transport associated with building and operating the GDF, such as the illustrative transport operator dose assessment presented in the generic Transport Safety Case, require knowledge of the routes to the GDF. As a site for the GDF is yet to be identified, the approach for the generic design is to identify seven notional GDF locations, with one notional GDF location at the centroid of each of seven zones covering England and Wales as shown in Figure 4.

Figure 4 Map of the notional GDF location zones

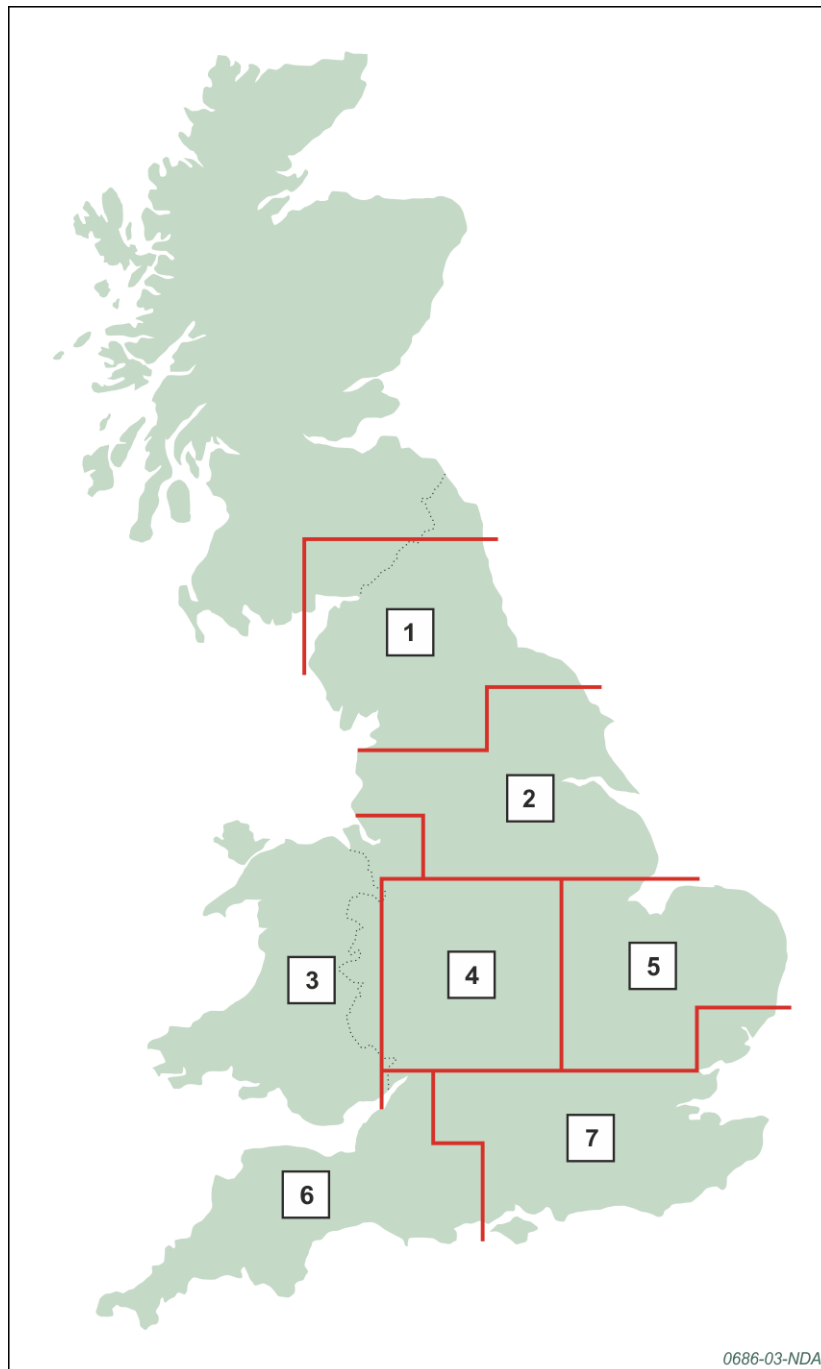

3.5 Mode of transport

Radioactive waste is expected to be transported from waste producing sites to the GDF in one of three ways:

- by rail, from a rail siding within the consignor site boundary direct to the GDF
- by road to an off-site railhead, and thence by rail to the GDF
- by road direct to the GDF

Similarly construction materials, spoil and personnel associated with building and operating the GDF will also be expected to arrive at the GDF by road or rail.

The current assumption employed by the NDA, as set out in their Transport and Logistics Topic Strategy [23], will be to use rail over road where practical. In conjunction with RWM, it is expected that each waste-producing site will use the most appropriate transport mode(s) for its own purposes.

The transport modes used will depend upon a wide range of factors, including the transport infrastructure available at the time the GDF becomes operational. Those responsible for defining the transport system at the time, whether it be waste producers, or some other controlling body, will need to take account of the economic, social and environmental factors applicable at that time when selecting suitable transport modes and routes.

When a potential site has been selected, the need for improvements to the transport infrastructure serving the site will be reviewed. A site must have suitable access to the national Strategic Road Network and to rail trunk routes. This access must have sufficient capacity for the transport conveyances described in Section 6. This may result in requirements for new infrastructure and/or improvements to existing infrastructure. The impact of the provision of new or improvements to existing transport infrastructure is anticipated to be a consideration in site selection. A further consideration is anticipated to be the availability of inland waterway or sea transport, or proximity to existing sea transport facilities. The viability of transport by inland waterway or sea is dependent upon the location of the GDF and these modes are not considered at the generic design stage.

Although the transport work reported in this document indicates that the current transport infrastructure system will be suitable for the predicted transport requirements, it will be prudent to monitor developments in this area so that appropriate action can be taken in a timely manner to ensure that adequate transport infrastructure is in place when and where required. Planning for changes to the transport infrastructure shall be undertaken on a timescale that allows changes to be implemented prior to any need for significant movement of materials from or to the site of the GDF. In doing so, due consideration will need to be given to the necessary timescales for design, development, planning applications, site licensing requirements and for the physical work needed to implement any required transport infrastructure.

3.5.1 Rail

Railheads located either within or close to waste-producing sites will be used for the dispatch of waste by rail. Waste will be transported by rail to the GDF directly from these rail heads. The train operating company and appropriate rail infrastructure company will determine the route from the on-site rail siding or off-site railhead, as appropriate.

On-site rail sidings and off-site railheads will require appropriate infrastructure to enable the transfer of transport packages from road to rail vehicles, such as cranes. The provision of suitable infrastructure will be a consideration in selecting routes.

The national rail network as shown in Figure 5 will be reviewed by the appropriate national rail infrastructure company, and the train-operating company, to identify national rail routes as the common 'backbone' of all routes to the GDF. These are likely to include rail trunk routes, for example the West Coast Main Line and the East Coast Main Line.

It is expected that a new rail line will need to be provided for the GDF to connect it to the national rail network. The provision and routing of any new rail infrastructure will need to be considered by a Transport Assessment (see Section 2.4) as part of the development to minimise and mitigate its impacts.

Figure 5 Map of the national rail network

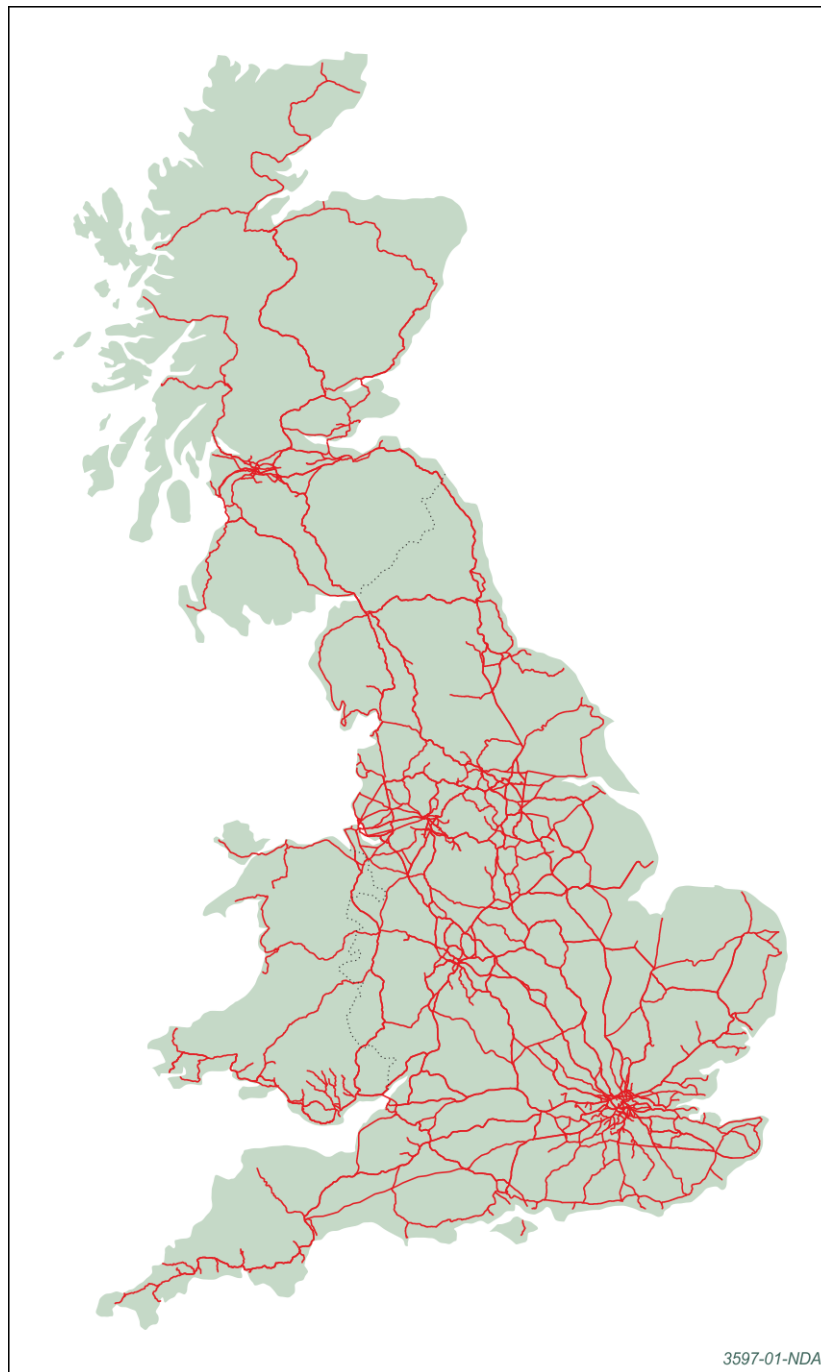

3.5.2 Road

For wastes transported using road transport, the routes local to each waste-producing site will be those that are safest and most secure for the vehicles involved. In general, the route from the waste-producing site to a trunk road will be as short as reasonably practical, taking account of impacts on settlements or other receptors. A network of national road routes will be identified as the common 'backbone' of all routes between individual waste-packaging sites and the GDF. This is likely to consist primarily of the national Strategic Road Network within England and the Trunk Road Networks in Wales and Scotland as shown in Figure 6.

Figure 6 Map of the strategic road network (England) and trunk road networks (Scotland and Wales)

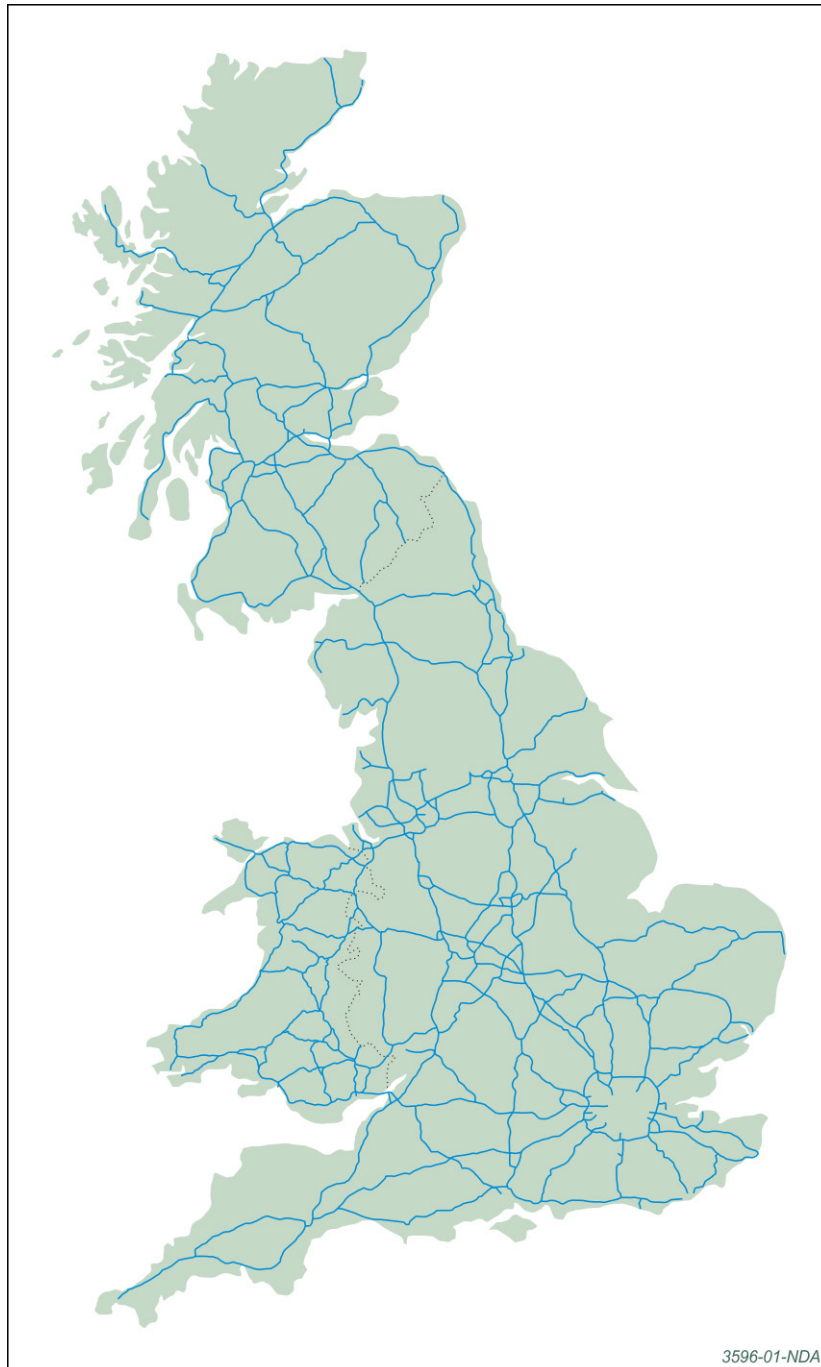

As is current practice in the road transport of radioactive material in the UK, secure, segregated parking areas, such as nuclear-licensed sites or other secure facilities will be designated for overnight stops. Such sites will also be identified for use in the case of major road transport disruption.

It is expected that a new roadway will be provided for the GDF to connect it to the Strategic Road Network. The provision and routing of any new roadway and onward routing of road vehicles to the GDF using existing infrastructure will be considered by a Transport Assessment as part of the development of the GDF to minimise and mitigate the impacts of road transport.

3.6 Waste types and transport rates

The wastes to be included within the GDF fall into two main categories, LHGW and HHGW.

LHGW is further broken down into waste groups as follows:

- legacy shielded ILW (SILW)
- legacy LLW
- legacy unshielded ILW (UILW)
- DNLEU
- nuclear new build (NNB) ILW and LLW

HHGW is further broken down into waste groups as follows:

- HLW
- legacy spent fuel (SF)
- Pu
- HEU
- NNB SF
- mixed oxide (MOX) spent fuel

Assumptions have been made regarding the timings and throughput rates of radioactive wastes to develop an operational programme. This provides a basis for undertaking safety assessment, and analysing the logistics associated with moving wastes to the facility. The rate of handling and emplacing these waste packages is within the maximum tolerances of the throughput levels currently assumed for the GDF and the facility will have the flexibility to dispose of smaller or larger number of total waste packages per year. Disposal rates have been based on earlier studies [24,25] or from information drawn from other national programmes. The operational assumptions are consistent across the three illustrative designs.

RWM assumes as its planning basis that the GDF will be available to receive LHGW in 2040 and HHGW in 2075. It is recognised that the basis for the siting process is consent-based and partnership, and consequently the process is driven in large part by discussions with local communities. Therefore this date, like all other aspects of the current GDF programme, must not be seen as fixed, but rather a reasonable basis for planning based on current assumptions.

The timing of the receipt of wastes at the GDF is based on information in the plans of the waste holders, for example the lifetime plans of the site licence companies. These site licence companies are responsible for decommissioning and clean-up at sites within the NDA estate where wastes are stored or will be produced in the future. There is considerable scope for refining the plans, and close co-operation with both public and private sector waste holders is envisaged in this area.

For the 2013 Derived Inventory, the assumed throughput for LHGW will average approximately 2,300 disposal units per year from 2040 to 2063. Between 2063 and 2108 the assumed throughput will reduce to an average 1,500 disposal units per year. DNLEU packaged in 500 litre drums (UILW) will be emplaced at a similar rate (1,500 disposal units per year) once the legacy UILW has been emplaced and would take approximately four years, until 2112. DNLEU packaged as SILW will be emplaced following the completion of emplacement of DNLEU packaged in 500 litre drums. The rate of disposal is assumed to be similar, resulting in the emplacement of these packages over a six year period, by 2118. NNB ILW will be emplaced in parallel with the end of legacy ILW/LLW and DNLEU (UILW) from 2100 to 2140.

The disposal of legacy HLW and SF is assumed to commence in 2075 and continue until 2105 at an assumed throughput of 200 disposal containers per year. Disposal of Pu and HEU will be scheduled to follow the disposal of HLW and SF, from 2105 to 2110. MOX is assumed to be available for disposal at 2131 based on the rate of cooling, and will take approximately 14 years to dispose. Subsequently, spent fuel from the 16GW(e) new nuclear power stations programme will take 45 years to dispose of up until 2190. The operational programme for disposal of the 2013 Derived Inventory is shown graphically in Figure 7.

Generally one disposal unit will occupy a single road vehicle or rail wagon, although in some limited circumstances two or more disposal units can be accommodated in a single road vehicle or rail wagon. Section 4 provides more detail on wastes and transport packages. Section 6 provides more detail on transport conveyances and their capabilities. Thus generally speaking, the transport of one disposal unit will result in one road transport movement and/or one rail wagon movement, noting that a train will comprise of up to twelve rail wagons.

Figure 7 GDF timing of disposal

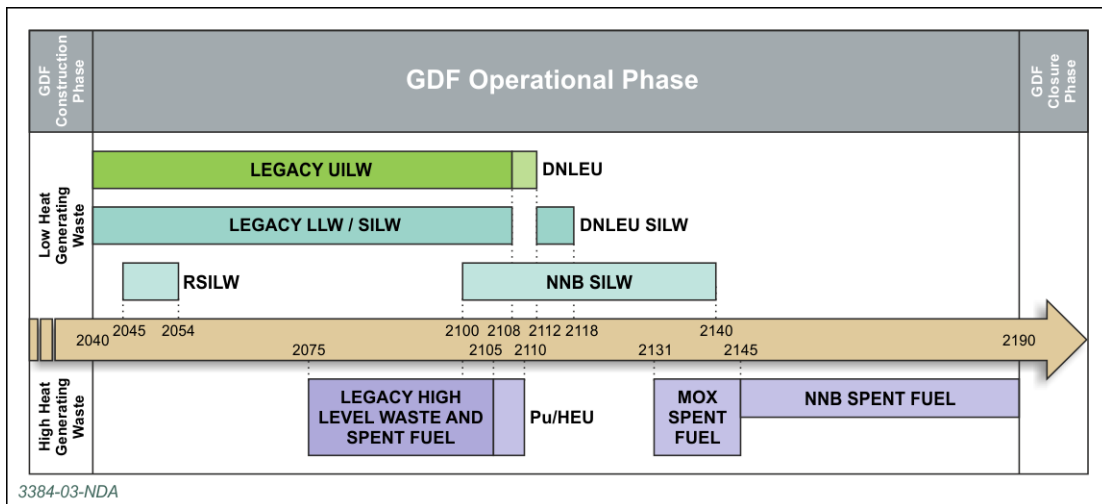

4 Radioactive Waste and Transport Packages

4.1 Transport arrangements

Recognising that many waste packages have yet to be manufactured and decisions about their ultimate design have not yet been made, it has been necessary to make assumptions regarding the form of conditioning and packaging for the purpose of the generic transport design. The types of waste package that will need to be transported to the GDF are described in the Waste packages and the assessment of their disposability report.

4.2 Waste packages that are transport packages

Some waste packages can be transported without the need for additional protection. These packages include 6 cubic metre boxes, 2 metre boxes, 4 metre boxes for ILW/LLW, and TDC for DNLEU. These waste packages meet the requirements for being safely transported through the public domain in their own right.

The 6 cubic metre concrete box will be used to transport ILW as a IP-2 rated transport package in compliance with the requirements of the IAEA Transport Regulations [26]. A 6 cubic metre concrete box is presented at Figure 8.

Figure 8 6 cubic metre concrete box



As for the 6 cubic metre box, the 2 metre and 4 metre boxes will be used to transport ILW or LLW as an IP-2 rated transport package. A 2 metre box is presented at Figure 9. A 4 metre box is presented at Figure 10.

Figure 9 2 metre box**Figure 10** 4 metre box

A conceptual design for the TDC is planned to be produced. It will also be an IP-2 rated transport package and will contain a range of inner containers in which DNLEU is planned to be stored. An illustration of what a TDC may look like is presented at Figure 11.

Figure 11 Transport and Disposal Container

4.3 Waste packages that will be overpacked for transport

RWM is designing and developing two types of transport container: the SWTC for the transport of some LHGW and the DCTC for the transport of HHGW. In addition a transport overpack will be used to transport some LHGW.

4.3.1 SWTC

The SWTC designs are a family of transport containers designed to carry waste packages containing ILW/LLW or DNLEU. There are three variants, each with a different shielding thickness; 70mm, 150mm and 285mm, respectively designated as the SWTC-70, the SWTC-150 and the SWTC-285. These shielding thicknesses have been selected to suit the range of wastes to be transported, whilst maintaining compatibility with the geometrical and mass constraints for road and rail transport.

The SWTC-70 and SWTC-285 have similar cavity dimensions determined by the dimensions of the contents; four 500 litre drums in a stillage, one 3 cubic metre box, either the side-lifting variant or the corner-lifting variant, or one 3 cubic metre drum. The SWTC-150 has a slightly larger cavity dictated by the need to carry the Miscellaneous Beta Gamma Waste Store (MBGWS) box. Its larger cavity also provides a means for transporting 500 litre robust shielded drums or standardised waste packages that might be 'overpacked' within a protective stainless steel outer layer in the event of unplanned handling damage to the waste package.

Compliance with the IAEA Transport Regulations for Type B packages means that the total transport package will be designed to withstand not only conditions of normal transport, including minor mishaps, but also transport accident conditions, including impact, fire and water immersion, while sustaining no significant loss of either shielding or containment.

There are four feet on all SWTCs which allow them to be accurately and safely tied down for transport. The SWTCs are designed so that all of the following operations can be carried out either remotely or hands-on:

- leak testing of seals
- lifting of the complete loaded SWTC
- lifting of the empty container body
- lifting of the lid
- operation of the purge/vent valve
- securing/releasing of the lid bolts
- loading/unloading of contents

The SWTC-285 is presented as an example at Figure 12.

Figure 12 SWTC-285

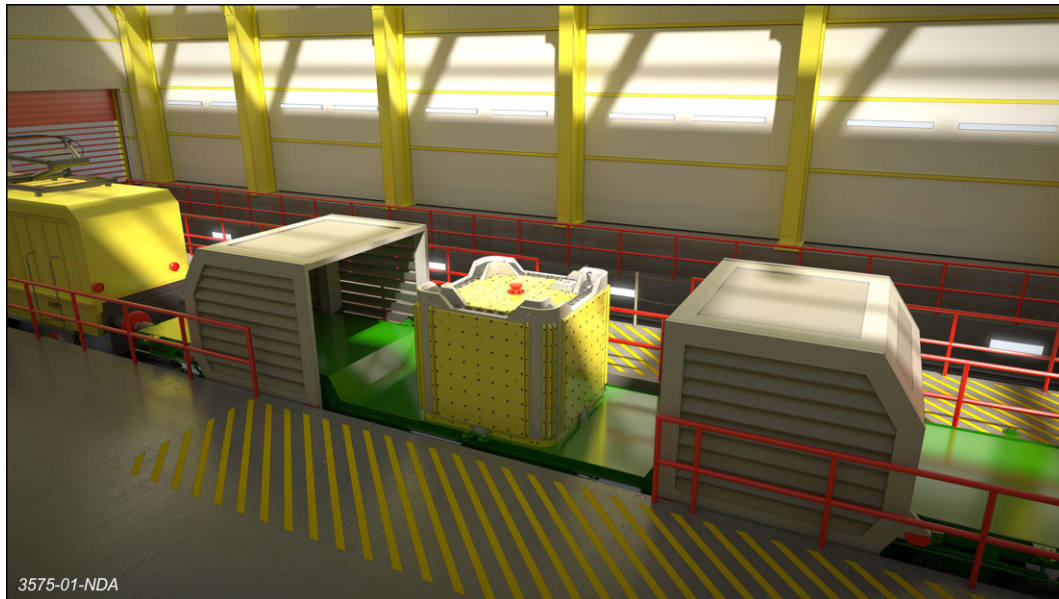

4.3.2 Transport overpack

Some RSILW and NNB SILW will be transported to the GDF within a transport package or transport overpack design, which is based upon a 20-foot ISO freight container. A transport overpack is an enclosure that forms one unit for convenience of handling and stowage during transport, but does not form part of the approved transport package, whilst a transport package is the approved packaging. Each will carry either:

- two 500 litre robust shielded drums in their Type B configuration, with shock absorbers. Once fitted with shock absorbers a 500 litre robust shielded drum comprises a Type B transport package under the IAEA Transport Regulations
- three 500 litre robust shielded drums. In this case either the 500 litre robust shielded drum or the freight container may be qualified as the IP-2 transport package under the IAEA Transport Regulations
- one 3 cubic metre robust shielded box. In this case either the 3 cubic metre robust shielded box or the freight container may be qualified as the IP-2 transport package under the IAEA Transport Regulations
- four 500 litre concrete drums, each as an IP-2 transport package under the IAEA Transport Regulations
- three 1 cubic metre concrete drum, each as an IP-2 transport package under the IAEA Transport Regulations.

An illustration of what a transport package or transport overpack based upon a 20-foot ISO freight container may look like is presented at Figure 13.

Figure 13 Transport Package or Transport Overpack based upon a 20-foot ISO freight container

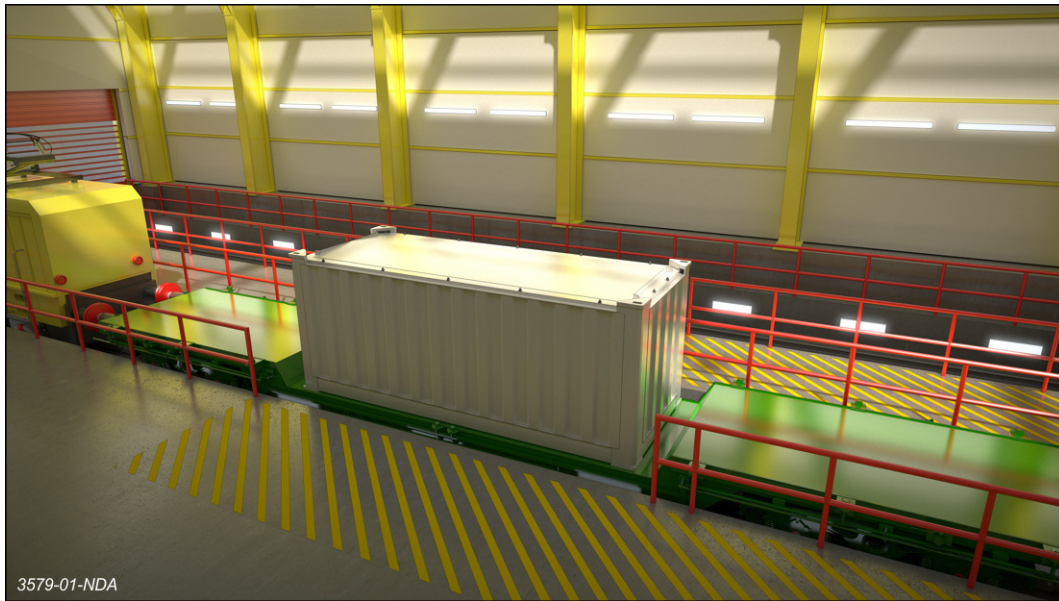

4.3.3 DCTC

RWM has developed a concept design for the DCTC that will be used for the transport of disposal containers containing HHGW. The outline design developed for the DCTC [27] proposes that the DCTC has a dumbbell configuration consisting of:

- a cask body
- a bayonet contents retention system
- a cask lid attached to the body by bolts
- a pair of impact limiters enclosed in steel housings at each end of the cylindrical cask body

The cylindrical shape of the DCTC makes it necessary to support it within a transport frame during shipment. It is fixed by means of four trunnions, two on either side of the DCTC body. The transport frame will be secured to the transport conveyance. The trunnions will also be used as lifting points for any lifting operations during transport. A DCTC is shown in Figure 14.

The DCTC outline design can accommodate a disposal container containing either HLW or legacy SF. A compatibility assessment [28] has considered whether the design could accommodate or be adapted to accommodate the other HHGW in the Derived Inventory. Some of the other HHGW would require an increase in the length of the DCTC or potentially an increase in the shielding provision. These modifications would be expected to increase the gross mass and would result in changes to rail wagon requirements described in Section 6.1.

Figure 14 DCTC fitted with impact limiters at each end

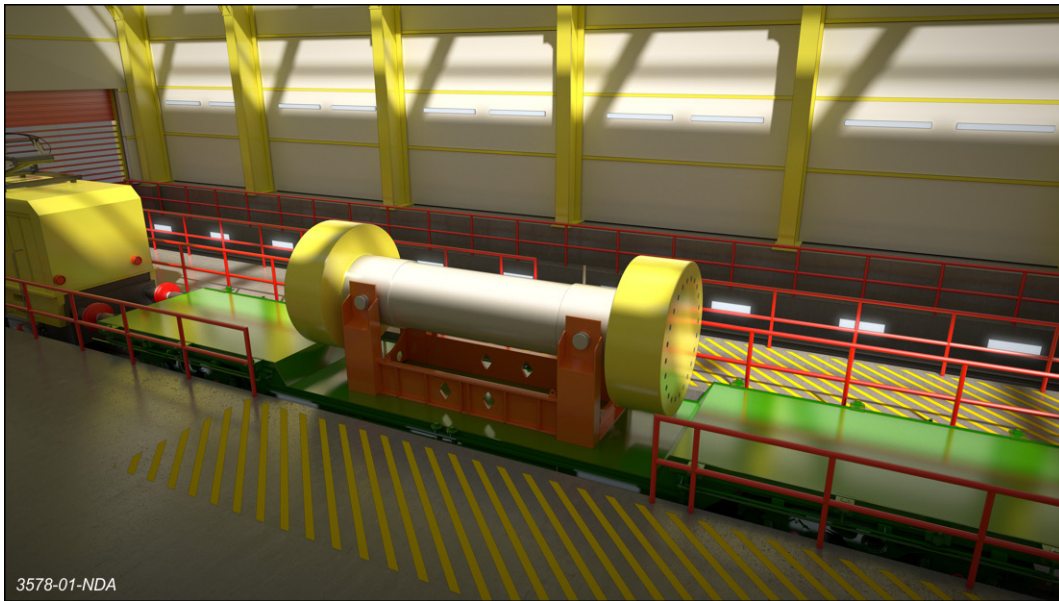

4.4 Summary

A summary of waste packages and transport arrangements is given in Table 1.

Table 1 Summary of illustrative waste and transport packages

Waste type	Waste category	Waste package	Transport arrangement
LHGW	ILW	500 litre drum	SWTC-70, SWTC-285
		3 cubic metre box	
		3 cubic metre drum	
		6 cubic metre concrete box	Transported as is
		2 metre box	Transported as is
		4 metre box	Transported as is
		MBGWS box	SWTC-150
		500 litre robust shielded drum	Transport overpack, SWTC-150
		3 cubic metre robust shielded box	Transport overpack
		1 cubic metre concrete drum	Transport overpack
	500 litre concrete drum	Transport overpack	
	LLW	500 litre drum	SWTC-70, SWTC-285
		4 metre box	Transported as is
	DNLEU	Transport and Disposal Container	Transported as is
		500 litre drum	SWTC-70, SWTC-285
HHGW	HLW	Disposal container	DCTC
	SF ⁴		
	Pu		
	HEU		
	MOX SF		

A summary of the transport arrangements is given below in Table 2.

⁴ This includes both Legacy spent fuel (Magnox, AGR, PWR and PFR) and spent fuel arising from a programme of new nuclear power stations

Table 2 Summary of illustrative transport packages or overpacks

Package	IAEA type	Dimensions (length x width x height) (mm)	Max. gross mass (t)	Container disposable or reusable
Six cubic metre box	IP-2	2210 x 2438 x 2200	40	Disposable
2 metre box	IP-2	1969 x 2438 x 2200	40	Disposable
4 metre box	IP-2	4013 x 2438 x 2200	65	Disposable
TDC	IP-2	6058 x 2000 x 2400	65	Disposable
SWTC-70	B(M)	2418 x 2418 x 2170	30 ⁽⁵⁾	Reusable
SWTC-150	B(M)	2439 x 2439 x 2218	40	Reusable
SWTC-285	B(M)	2439 x 2439 x 2171	65	Reusable
Transport overpack	IP-2 or B(U)	6058 x 2438 x 2591	30	Reusable
DCTC	B(U)	6395 x 2270 x 2270	65 ⁽⁶⁾	Reusable

⁵ The weight of the SWTC-70 is designed to ensure that the package is road legal in the UK when transported on a normal HGV with a gross weight of 44t.

⁶ Includes provision for a transport frame.

5 Materials and Personnel Transport

5.1 Introduction

The construction and operation of the GDF will generate both local and national transport movements to and from the site. This will involve the transport of construction workers and operational staff, construction materials and equipment, and visitors. Some of these will be local movements (for example construction workers and operational staff commuting to work) and some will be regional or national (for example the transport of construction materials to the site). Local infrastructure improvements may be required to ensure timely delivery and dispatch of personnel, materials and goods in line with the GDF schedule.

The construction and operation of the GDF and its associated transport infrastructure may present opportunities to improve the local transport network around the site, with associated benefits for the local community. It may result in some potential adverse transport effects. Where such effects are identified, mitigation measures will be put in place to ensure that any adverse effects are either avoided altogether, or reduced to acceptable levels.

It is not possible to develop detailed designs of materials and personnel transport systems for the GDF until a site has been identified, as the transport systems will need to take into account local matters such as the local rail and road infrastructure, public transport availability, and the relative locations of local workforce and materials.

All construction materials, equipment, excavated spoil, personnel and radioactive waste will be transported in accordance with the relevant safety requirements defined by the applicable regulations.

Two stages have been considered:

- the initial construction of the site during which no radioactive material is present and which can be considered as a conventional civil engineering project
- the second stage takes account of excavation and construction, requiring the movement of materials, taking place once the GDF is operational, when additional provisions will be required to maintain radiological safety

5.2 Construction material

An assessment has been undertaken to assess the transport movement of construction materials to the GDF based on the illustrative designs. This assessment will be updated when a site-specific facility design is developed.

A range of construction materials will be required for the GDF. At this stage, the surface materials have been grouped into the following categories for the purposes of assessing the requirements of the transport system:

- concrete
- reinforcement
- brickwork/blockwork
- steelworks
- wall/roof cladding
- roof tiles
- insulation

- road construction materials (subgrade, sub base, road base, binder course and surface course)
- fencing

Provision will be made in the design of the GDF to permit the receipt of construction materials by both road and rail. Particular consideration will be given to the use of rail transport for bulk materials, including bulk powders, cement and aggregates.

There are a range of options for the handling of construction materials and the actual methods employed will depend on the type and quantity of the specific material. The handling facilities provided will be purpose designed for the entire range of materials to be used. The design and operating procedures for construction material unloading facilities will ensure that the environmental impact of the operation, particularly in respect of noise and dust generation, is as low as reasonably practical.

The construction activities have been split into two main types; those required to construct the surface components of the GDF and those required to construct the underground components of the GDF.

The surface facilities that will be constructed will include the buildings on the site and other facilities required to support the operations of the site. Details of these facilities are presented in the GDFD report.

The construction materials and forecast peak vehicle movements associated with the construction of the surface facilities on the site are presented Appendix C.

The underground construction activities will require the import of different types of materials. It will also result in the excavation of material which will either be stored on the site, for later re-use as screening bunds or backfill, or be exported from the site. At this stage the underground construction materials have been grouped into the following categories for the purposes of assessing the requirements of the transport system:

- concrete
- mesh
- rockbolts
- shotcrete
- backfill

The generic illustrative design for the GDF considers three host rocks. The geological environment properties and the assumptions that underpin the illustrative designs affect the volume of construction materials required to be transported to the GDF. These are set out in the GDFD report.

Due to the assumed properties of the host rocks, the lower strength sedimentary rock requires larger volumes of rock support compared to the higher strength rock. No concrete support is currently assumed in the evaporite rock illustrative design. Due to the proposed backfilling approaches and the assumption that evaporite rock would creep to seal the disposal vaults, there is a requirement for less backfill materials to be imported compared to the other host geological environments.

In the lower strength sedimentary rock, it is currently assumed the disposal vaults and tunnels will be backfilled once each disposal vault has been filled. There is therefore a requirement to transport the backfill materials throughout the operational period of the GDF. However in the higher strength rock illustrative design it is currently assumed to backfill all disposal vaults once all waste has been emplaced. The backfill materials will therefore need to be transported to the GDF at this closure phase rather than during the operational period.

Construction of the surface facilities for the GDF will generate a similar number of total construction vehicle movements over the duration of the works for all illustrative designs. This equates to approximately 4,000-5,000 trucks in total (8,000-10,000 two-way movements) over the construction period. There are some differences between the peak years/volumes of construction vehicle movements between the different illustrative designs. This is primarily due to the level of detail contained within the programme and duration of construction activities assumed within the modelling exercise undertaken at this stage. Based on a c.10 year construction period, the average number of trucks will be 400-500 per year (800-1,000 two-way movements). Depending on the origin of construction materials and the availability of a rail head at the construction site, use of rail for construction materials may be able to reduce the number of truck movements required. However, the overall number of truck movements associated with the surface construction is low, even at its peak.

Construction of the underground facilities for the GDF will also generate transport movements. As with the construction of the surface facility, differences between the peak years/volumes of construction vehicle movements between the different illustrative designs is primarily due to the level of detail assumed within the modelling exercise undertaken at this stage. However, the majority of traffic movements are likely to be associated with the delivery of concrete and shotcrete to the site.

The underground construction materials and forecast peak vehicle movements associated with the construction of the surface facilities on the site are presented in Appendix C.

5.3 Excavation of spoil

Although the intention is to reuse spoil on the site as far as is practical (for example - using as screening bunds), there will be a need for surplus spoil to be removed from the site. It is currently assumed that spoil will predominantly be removed from site by rail transport. However, it may be necessary to use road transport for the export of small quantities of material.

Conventional rail wagons are expected to be used for any rail transport of spoil from the site. Spoil-loading facilities for rail wagons will be capable of top-loading both two-axle wagons and four-axle wagons.

Loading facilities may require the train either to be stationary during loading, or to be hauled slowly through the loading facility. In the latter case, vertical alignment of the railway line will be such that the whole train is on level track during the loading operation, and the horizontal alignment will allow the driver to see back down the whole length of both sides of the train.

The rail wagons will be hauled through the loading facility by an on-site shunter. Once the site is operational, the movements of spoil wagons and main-line locomotives for the spoil trains will be kept separate from any movements of waste trains, and separate from the sidings where waste trains are shunted and parked.

Conventional road vehicles will be used for any road transport of spoil from the site, if required. If excavated spoil is loaded into road vehicles, this will be by means of top loading.

Spoil-loading facilities may be combined so that they are capable of loading road vehicles as well as rail wagons, or they may be kept separate. The design and operating procedures will ensure that the environmental impact of the loading operation, particularly in respect of noise and dust generation, is as low as reasonably practical, taking into account social and economic factors.

An assessment of the excavated spoil has been undertaken for the illustrative designs for the GDF in each of the three host rocks. There will be a total of 10,800,000m³ of excavated material for the higher strength illustrative design, 8,800,000m³ for the lower strength sedimentary rock illustrative design and 6,500,000m³ for the evaporite rock illustrative design. These volumes exclude any bulking.

5.4 Storage of excavated material on-site

The preference is to minimise the off-site disposal of spoil by using it onsite as far as is reasonably practical. However it is recognised that this is not the case for the evaporite rock illustrative design where the arisings from underground construction are assumed to be unsuitable to be used in screening bunds around the site, due to the nature of the host rock, and will be transported offsite.

It is currently proposed that screening bunds will be used to store excavated material onsite to reduce the need for offsite transport movements. The excavated material will be stored and used for backfill at the appropriate stage. This will have a significant impact on vehicle numbers. There will be a limit on the amount of material that can be stored as screening bunds on the site. Once this limit has been exceeded, the excavated material will need to be exported. Conversely, where there is insufficient material stored on the site for backfill, external spoil will need to be imported to the site.

In the current illustrative designs for a higher strength rock and lower strength sedimentary rock environment, bund capacity has been optimised to provide the maximum volume of surface storage for excavated spoil within the assumed surface footprint, taking into account the likely effect of the screening bunds themselves on landscape character and visual amenity (largely in terms of their assumed height). The regular plan and profile of the screening bunds in the illustrative designs highlights their artificial, engineered nature. In reality, the screening bunds will be designed, as far as possible, to 'fit in' with the local topography and landscape character.

There will be no construction spoil retained on site associated with the evaporite rock design and any screening bunds will be constructed using only materials from site clearance. It also currently assumed that the excavated spoil in the evaporite rock illustrative design will not be used as backfill material, therefore all backfill material will need to be imported and all excavated spoil will be exported.

5.5 Personnel

The detailed requirements of personnel transport will be considered as part of the GDF construction phase plan and operations management plan at such time that a site has been selected. The management of trips to and from the site will be location specific. These will be developed in an environmentally sensitive, cost-effective manner, making due allowance for local needs and sensitivities. Once a site is selected Construction Worker Travel Plan and a Construction Traffic Management Plan will be developed in discussion with the relevant planning and highway authorities. The largest proportion of movements is expected to be from staff commuting to and from site. The average direct employment numbers in the planning, borehole construction, tunnel construction, operation and eventual closure of the GDF is forecast to be approximately 500 personnel during the operational period of the GDF. It is estimated that around 1,000 personnel will be needed during the peak of construction activities in the initial construction phase. Transport movements for personnel are based on direct jobs from studies on the manpower and skills required for the construction and operation of the GDF [29]. The transport movements do not consider personnel movements associated with any consequent indirect or induced jobs (such as jobs in the local supply chain for the GDF, or in the wider local economy).

The generic design considers that personnel will most likely arrive at the GDF either by road or by rail. Once a site is selected the availability of commuter routes will need to be understood, and the origins and duration of staff commuting from a location with a rail station should be established to assess viability of a rail offer.

A car park and bus terminal will be located outside of the GDF boundary fence and shuttle buses will take personnel from the car park bus terminal to the security gatehouse. Personnel will leave the bus; pass through security turnstiles before re-boarding the bus. This will ensure that cars and regular service buses are not driven onto site.

Once a site is selected consideration will be given to the feasibility of removing or minimising the need from car travel by providing buses direct from accommodation centres. The railway station will also be located outside of the perimeter fence of the GDF. Coaches will operate as with the park and ride system to move personnel to and from the railway station. Coach parking areas will be located within the boundary, close to the main facilities to allow for dropping off and picking up of personnel during shift changes. Further details are provided in the GDFD report.

The number of anticipated trips related to personnel working at the GDF is included within Appendix C. It does not include train journeys as these are dependent on the actual location of the GDF. A railway station has been included in the illustrative designs, located outside of the GDF perimeter fence. However, the viability of a rail service for workers has yet to be assessed in light of the numbers regularly commuting to and from the site. The number of rail journeys will be specific to the location of the GDF, the origin of staff commuting and of the local rail infrastructure. If it was operated in parallel with a bus park and ride scheme, it may predominately reduce the number of personnel using the park and ride rather than the number of cars accessing the site directly, as staff requiring direct access by car may already have been taken off the road network with the bus operation.

A visitors' centre is expected to be in place during construction and waste emplacement. Visitors will be expected to peak in the summer months, depending on the location of the GDF, for example if it is near a tourist destination. It is also expected that educational trips for pupils and students will be a relatively high proportion of the visitors, and that these are likely to be less seasonal, with a tendency to be away from the summer period. The number of vehicles movements associated with the visitors centre will need to be estimated for the Transport Assessment for a potential site. An estimate is not given for the generic design as the GDF location is expected to significantly influence visitor numbers.

6 Transport Conveyances

This section provides an overview of the transport conveyances for the proposed GDF transport system. Dimensioned drawings of the conveyances are presented in Appendix D

6.1 Rail wagons

Rail wagons will be required for movements of excavated spoil, construction materials and transport packages containing radioactive waste over the national rail network. Construction materials and transport packages will be off-loaded from main-line rail wagons on arrival at the GDF. If a drift is included in the GDF design as the means of taking transport packages underground, these main-line rail wagons will be prevented by engineered means from access to the drift for security considerations.

A main-line rail wagon design, as described in [30], has been developed to comply with the following requirements:

- the wagon will be capable of carrying any of the waste package types, loaded in a transport container where appropriate, to a maximum gross mass of 65 tonnes
- the wagon will be capable of carrying all such packages singly, or in multiples or combinations that meet the other design requirements
- the wagon will have an axle loading of no greater than 22.5t when fully loaded
- the wagon will comply with the national rail infrastructure loading gauge (currently W6A)
- the wagon will be designed for operation at 100km/h as part of a train with a trailing load of up to 1800t

The resultant rail wagon design is a two-bogie, four-axle wagon with a central well deck and a length of 16.6m. Transport packages will be carried in the well deck, and will be subject to limitations on weight, size and tie-down compatibility set out in the following sections.

After completion of the rail wagon design work, further studies were carried out including examination of route availability over the rail network. Route availability refers to the maximum gross weight and axle weight of a wagon or intermodal unit/platform wagon combination. Similar to weight restrictions on sections of the road network, parts of the national railway infrastructure cannot accommodate the heaviest railway wagons.

There are currently 10 Route Availability (RA) categories on the national network numbered RA1-RA10. These are presented in Table 3.

Table 3 RA categories on the national rail network

RA Group	Single axle weight (tonnes)	Gross laden weight of vehicle (tonnes)	
		2-axle wagon	4-axle wagons
RA1	13.97	27.94	55.89
RA2	15.24	30.48	60.95
RA3	16.51	33.02	66.03
RA4	17.78	35.56	71.11
RA5	19.05	38.10	76.19
RA6	20.32	40.63	81.27
RA7	21.59	43.17	86.35
RA8	22.86	45.71	91.43
RA9	24.13	48.25	96.51
RA10	25.40	50.79	101.59

The wagons used will have an axle loading of up to 22.5t when fully loaded (RA8). Some parts of the network (notably some bridges and viaducts) are unable to accommodate this axle load at normal operating speeds. Network Rail approval will be required to operate heavier axle loadings over such routes. Solutions that have been used to overcome the lower RA rating includes operating at reduced speeds, using spacer wagons and alterations to the permanent way (track bed). Network Rail will determine applications to operate heavy wagons over lower RA rated routes on an individual case by case basis.

6.1.1 Loading rules

Based on the rail loading limit of 22.5t per axle, usage of the rail wagon, for normally loaded containers, will be:

- one SWTC-150 or SWTC-285
- two SWTC-70s
- one DCTC
- two 2 metre boxes
- one 4 metre box
- one 6 cubic metre concrete box
- one transport overpack
- one TDC

In order to ensure that the potential dose uptake to operating staff remains within acceptable limits, a minimum separation of 6m is required between any radioactive transport package and any continuously occupied position on the train, such as the rear cab of the locomotive. This can be achieved by ensuring that the adjacent end decks on the first wagon of a train are not used.

6.1.2 Rail wagon design development

As currently designed, the four-axle rail wagon has a tare weight of 26t; the axle loading constraint of 22.5t on each axle gives a maximum loaded rail wagon weight of 90t. The design of railway wagons for the GDF will be compatible with that of the transport containers, and the designs will proceed iteratively to ensure compatibility. If the future development of transport packages results in the need to carry transport packages by rail that are heavier than the limits for the current rail wagon design, further development of that design will be required. However, such a development will result in either adoption of a higher route availability requirement or a requirement for a heavier wagon with six or eight axles. Therefore, it is likely that the four-axle design will be retained as the standard vehicle for rail transport of transport packages. Should there be a need to transport heavier packages, these could be transported using either a six- or eight-axle rail wagon or by road. A rail wagon carrying an SWTC is shown in Figure 15.

Figure 15 Rail wagon with SWTC

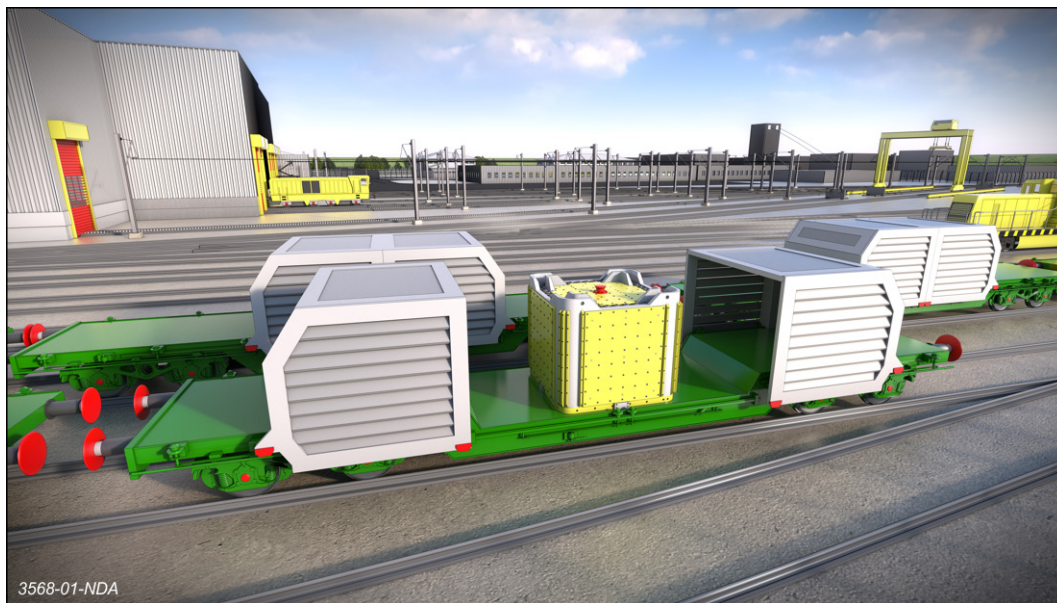

6.2 Road vehicles

Road vehicles will be required for movements of transport packages containing radioactive waste for the following journeys:

- directly from waste consigning sites to the GDF or port in the event that rail transport is not a viable option
- transfer from waste consigning sites to a railhead where transport packages are transhipped to rail wagons for onward movement to the GDF

EU Directive 96/53/EC [31] gives a maximum width of a road vehicle as 2.55m and a maximum length of 16.5m for an articulated road vehicle (with 12m trailer length). The maximum gross weight of compliant articulated vehicles is 44t.

Road trains – which consist of a rigid road vehicle at the front which pulls a road trailer behind - have a maximum length of 18.75m and a maximum width of 2.55m. These vehicles are limited on the weight of individual packages they can carry so their use will be restricted to typical packages with a gross weight of less than 15t.

Within the UK, road vehicles have to be designed, constructed and operated in accordance with the Road Vehicle (Construction and Use) Regulations (C&U) [32] which set out

standards to which new road vehicles will be constructed, together with standards and restrictions regarding their safe ongoing use on the highway network. Beyond these limits, there are Special Types rules [33] that permit abnormal indivisible loads to be carried that exceed the weight and/or dimensions limits specified above. An abnormal indivisible load is defined as a load that cannot without undue expense or risk of damage be divided into two or more loads for the purpose of being carried on a road and that:

- owing to its dimensions cannot be carried by a goods vehicle complying with the requirements of the Construction and Use Regulations
- owing to its weight cannot be carried by a goods vehicle having a total laden weight of not more than 44t and complying with the requirements of the Construction and Use Regulations

Some transport packages, when loaded onto a standard vehicle, will exceed the 44t limit for maximum gross weight and a Special Types General Order (STGO) vehicle will be required for these packages. Requirements relating to the size and weight of the tractor unit and trailer are also set out in the Special Type rules.

There are three STGO categories:

- STGO 1 has a gross weight limit of 50t, and the general C&U for maximum axle weights and speed limits apply
- STGO 2 has a gross weight limit of 80t and a maximum axle weight on twin tyres of 12.5 tonnes
- STGO 3 has a gross weight limit of 150t and a maximum axle weight on twin tyres of 16.5t

Limits for the overall width and length of an STGO vehicle are set at 6.1m and 30m respectively.

Notification needs to be provided to various authorities for such movements, this can be conveniently done via Electronic Service Delivery of Abnormal Loads (ESDAL) [34], including the following:

- police notification is required for movements where the combined vehicle and load exceed one or more of the following: a width of 3m, a rigid length of 18.75m or a gross weight of 80t
- road and bridge authorities require notification where the gross or axle weights exceed the limits in the C&U regulations

The designs for STGO Category 1 and 3 vehicles were reviewed in 2012 [35] taking into account changes in available equipment and are described below.

- an STGO Category 1 vehicle can be used to carry one SWTC-70, one six cubic metre box, one or two 2 metre boxes (depending on the combined weight), one lighter 4 metre box or one transport overpack not exceeding 30t in weight. This vehicle, as currently designed, can be dual plated as a heavy goods vehicle (HGV) that complies with the Construction and Use Regulations. It will be noted that if the decision is taken to transport the packages without covers then the majority of these packages will be transported within normal width limits and hence the vehicle can be single plated as a normal HGV. The fitting of sliding covers would increase the trailer width beyond the 2.55m C&U Regulations limit for HGVs
- an STGO Category 3 vehicle able to convey either one SWTC-150, one SWTC-285, one DCTC with a transport frame, one TDC or one 6 cubic metre concrete box, one 2 metre box or one 4 metre box exceeding 30t in weight

6.2.1 C&U/STGO Category 1 vehicle

A HGV that complies with the C&U regulations, but exceeds the 2.55m C&U width limit, will be an STGO Category 1 road vehicle. However, the vehicle will have a special Department for Transport (DfT) dispensation to operate as a normal C&U or Authorised Weight (AW) rules [36] vehicle, with no operating restrictions whenever it is loaded within the C&U and AW axle and gross vehicle weight limitations. The vehicle will thus be 'dual-plated' as a C&U/STGO Category 1 road vehicle.

This vehicle consists of a normal HGV tractor unit combined with a step-frame three-axle trailer unit as shown in Figure 16. This trailer can either be operated under normal C&U vehicle weight rules with a two-axle tractor unit and a gross vehicle weight (GVW) of 38t or, under AW rules, a GVW of 40t. With an uprated three-axle tractor unit, a GVW of 44t may be used under AW rules. In any of these configurations, there will be no operating restrictions on main traffic routes. The trailer is fitted with pneumatic suspension units (road-friendly suspension), which ensure least damage to road surfaces.

The same trailer can also be used as part of an STGO Category 1 vehicle with a GVW up to 50t. This configuration will result in a slightly longer vehicle with overall dimensions of 16.5m length, 2.77m width and 3.53m height. The height and width of the trailer govern the height and width of the whole vehicle. The trailer length is approximately 11.0m from the centre of the kingpin at the tractor coupling, below the maximum permitted length of a trailer for this type of vehicle. This overall length is required so that the sliding cover, if fitted, can be adequately supported when in the fully open position. The front and rear ends of the covers remain fixed in position on the trailer bed at all times.

The weight of the trailer unit, with a front bulkhead shield plate and sliding covers fitted, is 15.1t and the operating weight of the three-axle tractor unit for AW or STGO Category 1 operation is 10.5t. The operating weight of a two-axle tractor unit for 40t GVW operation will be 7t. There will be a net gain in payload weight of up to 3t by operating to the 44t AW (six-axle) limits compared with the 40t AW (five-axle) limit, and therefore the outline trailer design provides a degree of flexibility at this stage of planning the transport system.

Figure 16 GC&U/STGO Category 1 vehicle with no covers



6.2.2 STGO Category 3 vehicle

A conceptual design has been produced for an STGO Category 3 vehicle which consists of a normal commercial three-axle tractor unit combined with a step-frame five-axle trailer unit as shown in Figure 17. The rear four axles of the trailer are power steered automatically as the tractor unit negotiates a turn. The overall dimensions of the vehicle are 18.05m length, 2.77m width, and 3.79m height. The height and width of the trailer govern the height and width of the vehicle. The trailer length is 12.74m from the centre of the kingpin at the tractor coupling. The weight of the trailer unit, with a front bulkhead shield plate and sliding covers fitted, is 19.1t, and the weight of the three-axle tractor unit is 10.5t. This combination of tractor and trailer can carry the current heaviest transport package weight of 65t, although potentially much heavier packages can be transported within the STGO Category 3 weight limit of 150t. Because of the higher weight of the STGO Category 3 vehicle, it is assumed that the trailer will be fitted with hydraulic suspension units which provide better anti-roll characteristics with heavier loads.

Consideration will be given to the local highway and to the Strategic Road Network to provide continuity for a STGO Category 3 design to enable transport packages to be brought to the site by road. Additionally, the use of STGO Category 3 vehicles may result in the need for the transport operator to undertake regular condition surveys on the routes utilised to allow for maintenance of roads to be accounted for.

Figure 17 STGO Category 3 vehicle with no covers



6.3 Construction and spoil vehicles

Different types of road and rail vehicles will be used for transport of non-radioactive material.

6.3.1 Rail wagons

The transport of bulk and palletised material using rail is widely practised and involves the use of open rail wagons to allow automatic or manual overhead loading. Each wagon would take approximately 3 to 4 trucks off the road.

Figure 18 to Figure 20 present examples of rail wagons that can be used for the transport of spoil and construction materials.

Figure 18 Open box wagon



The Open Box wagon in Figure 18 was designed specifically for the transport of spoil/ballast from rail renewal sites. The length, height and axle load can be changed to vary the volume or tonnage per unit length to suit. Unloading of the wagon is carried out by mechanical excavators.

Figure 19 Open-top box wagon

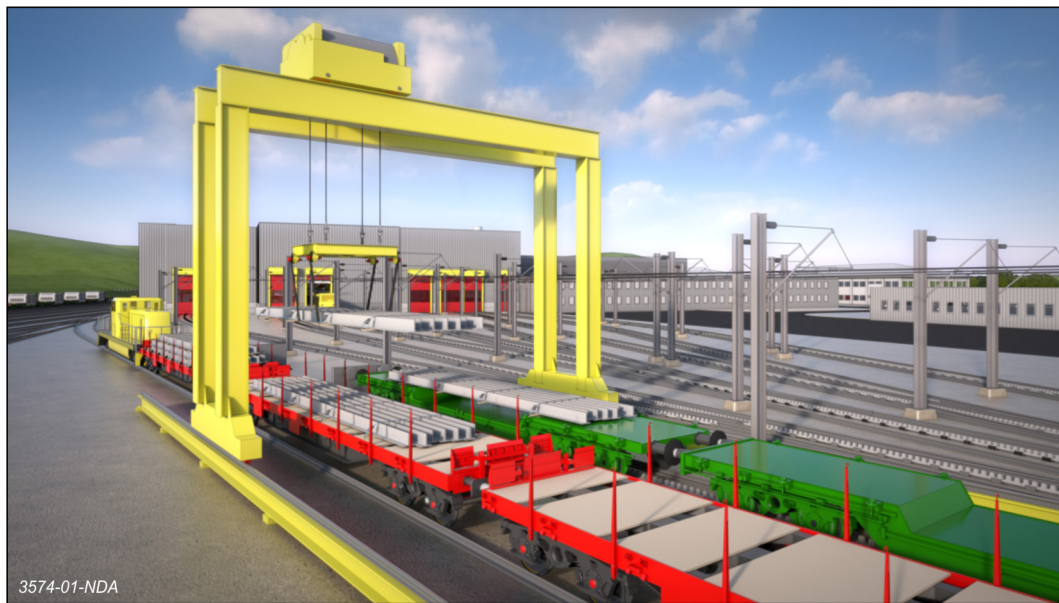

The Open-top Box wagon in Figure 19 can be loaded via top box opening or via four side openings. The wagon can be unloaded at the site from the side by rotary tippers via top box openings or manually via four openings (1,800x 1,800 mm) on the side.

Figure 20 Flat wagon

The flat wagon in Figure 20 is suitable for the transport of metallurgical products (steel tubes, profiles, and plates), wheeled vehicles, light track vehicles and containers. This wagon can be loaded from the top by crane, from the sides by vehicles or from the front of wagon after tilting the front flaps to create the transition platform. The wagon can also be used for bulk building materials and large pieces of steel work and precast material.

6.3.2 Road vehicle information

Road vehicles are the most easily accessible method of transport for a number of reasons:

- easy access to site
- trucks are able to drive right up to loading and dispatch points
- cost effective
- readily available
- generally compatible with existing infrastructure

Transport of spoil using road vehicles will be undertaken with tipper trucks to allow easy unloading. An example of a tipper truck is presented at Figure 21.

Figure 21 Commercial tipper truck



Other materials, such as construction material will be transported using larger, articulated vehicles, an example of which is presented at Figure 22.

Figure 22 Six-axle articulated vehicle



7 Transport System Management

7.1 Introduction

Transport system design will also reflect the NDA's Transport and Logistics Topic Strategy which requires Site Licence Companies (SLCs) to consider the following principles:

- ensure the safety and security of material movements, and protect people and the environment and consider the impact on the resulting carbon footprint
- optimise movements between sites whilst enabling other strategic themes
- seek to reduce the adverse impact of all transport modes throughout the transport routes
- find common and reliable packaging and coordinate transport arrangements to support movement and disposal requirements
- use rail over road where practicable
- maximise the use of existing assets rather than develop new ones

The Strategy also notes that SLCs are responsible for:

- identifying materials to be moved
- programming movements
- overall knowledge of stakeholders' needs in the fulfilling the Strategy
- demonstrating the aims of the Strategy will be met
- providing the options for all movement of materials once movement is required

An integrated transport system will be used to move wastes from waste consigning sites to the GDF combined with the transport of construction materials, excavated materials and personnel. The integrated system will utilise a common infrastructure for all transports, however as described in Section 6, different conveyances will be used for different types of transport movements to meet the specific needs of each movement type. The transport system for radioactive waste includes all of the processes, equipment and management arrangements required for the movement of waste packages from a waste consigning site to the GDF including, for example, loading of transport packages onto vehicles, monitoring of transport packages and vehicles, overnight stops and changes in transport mode.

The responsibility for demonstrating and providing a safe transport operation will be shared between a number of organisations for example consignors, carriers and the consignee (the GDF operator). At this early stage it has not been decided who will be directly involved in the transport operation, hence, responsibilities for providing a safe transport operation are not yet clearly assigned. As a consequence, RWM has taken responsibility for developing and maintaining this generic transport system design.

Much of the transport system will utilise existing infrastructure, with improvements made and additional facilities built where necessary to accommodate the volume and type of vehicle movements most efficiently. An integrated transport system for the movement of radioactive waste, construction materials, spoil and personnel essentially consists of four basic elements, namely:

- the transport packages and empty transport containers, materials, spoil and personnel to be transported
- 'Terminal' facilities located at the waste consigning sites, at the GDF and other intermediate locations, where transport packages are loaded to, unloaded from or

transferred between different transport modes. This will also be locations where materials and spoil will be loaded or unloaded.

- the actual transport operation between terminal facilities by road or rail
- the management of the total 'supply chain'

These four basic elements combine in various ways, depending on a variety of factors, to form an integrated transport 'supply chain' network between the waste consigning sites and the GDF.

A key feature for an integrated system is that the transport containers and all vehicles/wagons are used for all waste consigning sites. Sites will not have their own site-specific containers or vehicles. This will enable transport times to be better controlled, and help to achieve an even arrival rate at the GDF and make best use of equipment. This is likely to require a single management control organisation.

7.2 Operational management

The primary function of the transport system is to ensure that the required transport to and from a disposal facility is achieved in a manner that is safe, planned, timely, cost-effective, flexible and environmentally sound.

The key requirements on the management of the transport system are:

- ensuring that the transport process meets the needs of both the waste owners and the GDF operator
- ensuring that all safety procedures and other legal requirements (such as the IAEA Transport Regulations, dose minimisation and Nuclear Industries Security Regulations (NISR) [37]) are fully understood and implemented
- ensuring that both physical and human resources are available in sufficient quantities at the appropriate times and in the right locations
- ensuring that comprehensive contingency and emergency plans are in place, adhered to and fully communicated to everyone concerned, including the relevant civil emergency services
- ensuring that the costs and contracts set up with rail and road carriers to operate the transport system are established and maintained at a level which reflects both the quantity and quality requirements of the system

The transport system will be managed at a number of levels, including:

- strategic supply chain management
- operational management

The supply chain management role will be to co-ordinate the various road and rail transport systems with the operation of the GDF. This central role will be concerned with the planning of waste package movement and storage, strategic co-ordination between transport/site operators and monitoring of the system performance. The work will involve interaction with the arising sites, road haulage operators (either an in-house operation or third party contractors), rail freight traction providers, the GDF receipt operation and the emergency and security services (for emergency planning and exercises).

The operational management role will include scheduling transport routes and vehicles, managing drivers, and organising vehicle maintenance. It is likely that the role will be the responsibility of either RWM's in-house operators or appointed specialist contractors, and the main tasks to be carried out will include:

- day-to-day operations, with 24-hour cover on call to respond to any problems arising in the transport system

- tracking transport package movements using appropriate remote tracking systems
- operation of computer interfaces between GDF and waste owner databases to assure and maintain waste acceptance records
- liaison with waste owners, local communities, regulatory bodies and emergency services
- management of rail and road carriers
- road operations co-ordination to ensure that sufficient numbers of road vehicles are available to meet demands of the system
- rail operations co-ordination to manage the use of rail wagons and to optimise their use between all waste consigning sites, transshipment points and the GDF
- reusable transport containers operations co-ordination to manage the use of these reusable containers and to optimise their use between all sites
- technical support to the operation of the reusable transport containers, including assessment, approval and implementation of design changes, and authorisation of maintenance and repair proposals and procedures
- medium- and long-term planning of the integrated transport system
- maintenance of records pertaining to the reusable transport containers
- quality assurance
- radiation dose monitoring

In addition, suitably qualified and experienced personnel will be identified to fulfil the following key named operational roles:

- consignor – to be responsible for the preparation of packages and consignments for transport
- consignee – to be responsible for the receipt of packages and consignments from transport
- loader – to be responsible for the loading and unloading of packages onto, and from, transport vehicles
- packager – to be responsible for the assembly and loading, of transport containers prior to shipment and on receipt

7.3 Waste consignor transport operations

Under currently established arrangements, prior to any waste packages being dispatched to the GDF, a rigorous system of checking and monitoring of each transport package will be carried out by the consigning organisation (the waste owner or the organisation acting on behalf of the waste owner). This will ensure, in particular, that the specific identification of individual waste packages in terms of the nature and quantity of waste is confirmed and that the package complies with the waste acceptance criteria that will be established for receiving waste at a disposal facility.

Following receipt of packages at the GDF, administrative checks of the consignment, physical inspection of the transport package, and radiological measurements of surface dose and contamination will be carried out. This would confirm that no damage had been sustained in transport and act as a cross-check on the inspection carried out at the point of dispatch. Suitable facilities will also be available for handling any packages that do not meet acceptance criteria.

7.3.1 Transport of packages

Waste-consigning site facilities and procedures will be designed to be capable of receiving and dispatching transport packages by any practical combination of rail and road. If there is no rail connection to a waste consigning site, a suitable railhead will be identified to which transport packages can be transported by road for transfer to a rail wagon for onward transport to a local port or to the GDF.

The requirements for operating and handling, and turn-round (dispatch) maintenance and inspection of transport packages are developed as part of the regulatory approval case (Package Design Safety Report (PDSR)), and are approved by the appropriate Competent Authority (such as the Office for Nuclear Regulation (ONR)) if required for the package design type. These documents will be used at the waste consigning site, to facilitate compliance with regulatory requirements.

The waste consigning site facilities will be designed to allow all the activities relating to rail wagons (where there is an on-site rail connection) and road vehicles to be carried out. Provision will be made for checking the identity and documentation of each empty reusable transport container on receipt, and for inspecting it for damage or any other non-conformance. If a container is received with documentation containing errors, it will not be removed from its transport vehicle until the documentation errors have been satisfactorily resolved. The waste consigning site will include provision for holding such packages on its rail or road vehicle.

Road vehicle and rail wagon loading and unloading areas will permit transport packages to be lifted by a vertical lift overhead crane, or other safe and appropriate means, and will include adequate hard-standing for packages.

Contingency arrangements will be in place, including facilities to cover the occurrence of packages being found to be unacceptable for emplacement in the GDF, for example due to damage or degradation of the waste package. Typically, such waste packages will either need to be rectified to an acceptable state for transport and GDF acceptance, or overpacked to provide for onward shipment and disposal in the GDF. Notwithstanding this, it is a basic tenet of all aspects of operating the transport and packaging system that all reasonable steps and measures will be implemented to prevent and minimise damage, and damaging conditions, during transport and related operations.

In view of the many, and varied, operations that are required to ensure safe and efficient loading, handling inspection, maintenance and dispatch of what will be a large number of packages, there is clearly a need for waste consignors to consider whether they need to include provision for remote handling equipment, and facilities, in order to ensure they reduce risks to employees to as low as reasonably practicable (ALARP) as required by health and safety regulations.

7.3.2 Turn-round and export

Suitable turn-round and export facilities will be provided at waste consigning sites to allow the execution of the necessary turn-round handling, maintenance and inspection procedures, and export of the transport packages, as set down in the PDSRs for each type of package design.

Procedures and facilities will be provided to monitor internal and external surfaces, during turn-round maintenance and inspection, of all reusable transport containers, stillages, and external surfaces of waste packages.

7.3.3 Monitoring of consignments prior to departure

Suitable export facilities will be provided at waste consigning sites to allow the execution of any necessary maintenance and inspection procedures, and export of the transport

packages, as set down in PDSRs for each type of package design. Procedures and facilities will be provided to allow the completion of any minor repairs that have been identified during maintenance and inspection, subject to the approval of the repairs by the package design approval authority. Each transport package will be labelled before dispatch and fitted with one or more security seals, and/or padlocks, as specified by the design. This will be done before the package is placed on its transport vehicle.

Procedures and facilities will be provided to monitor external surfaces, during maintenance and inspection. This will include the monitoring of readily accessible surfaces of main-line rail wagons and road vehicles prior to dispatch. Procedures and facilities will be provided to decontaminate accessible surfaces of rail wagons when the measured non-fixed contamination levels exceed the limits defined in the IAEA Transport Regulations.

After successful completion of monitoring prior to dispatch, a Radiation/Contamination Monitoring Certificate will be provided for each rail wagon and road vehicle prior to its departure from the waste consigning site. Once it has received a Radiation/ Contamination Monitoring Certificate, the vehicle will not pass through any contaminated or potentially contaminated areas before leaving the site.

Before the arrival of the main-line locomotive, any trains to be dispatched will be shunted into their correct formation. A Certificate of Readiness will then be provided for the made-up train. Any load will be checked visually to ensure that the tie-down system is in good working order and that the load is correctly secured. Where covers are fitted, they will be correctly closed and locked.

7.4 GDF transport infrastructure and operations

This section outlines the generic transport-related requirements that have been incorporated into the rail and road system design on the GDF site. The design of the GDF is described in more detail in the GDFD report. It also outlines the generic transport-related requirements incorporated into the designs for facilities and operational procedures at the GDF. These requirements will also be considered in conjunction with the generic transport-related requirements that are expected to be incorporated at waste consigning sites.

An illustrative GDF design needs to demonstrate that all goods, services and transport packages can be received and dispatched by a combination of road and rail transport so as not to unnecessarily preclude any mode at this stage. The unlikely scenario where rail access to the site is not feasible is only considered at this stage in terms of whether the concept is amenable to modification which will allow the receipt and dispatch of all transport packages and other goods by road.

All parts of the on-site rail and road system where transport packages containing waste are stationary for significant periods of time awaiting onward movement, for example rail sidings and HGV parks, will be capable of being designated as Controlled Areas under the Ionising Radiations Regulations [38] (depending upon occupancy).

7.4.1 Facilities

Facilities are required to cater for the receipt of waste packages at the surface followed by transfer and emplacement of the waste packages underground within the GDF. The facilities will also need to handle the arrival and departure of personnel, the import of construction materials and the export of spoil and other materials. Surface transport requirements are envisaged to include:

- rail sidings for the:
 - receipt and dispatch of radioactive waste trains and shunters

- shunting of radioactive waste trains and transfer of rail wagons carrying transport packages to the waste package receipt area
- handling of construction material trains
- handling of trains to remove underground excavation spoil
- staff transport to/from site (if rail is a viable option)
- road systems to enable:
 - access of personnel to and from their required locations, and construction materials to be received at the required locations
 - empty road vehicles to be dispatched
 - other material & equipment to site
 - road vehicles carrying transport packages to be moved to the waste package receipt area
 - road vehicle parking
- maintenance and repair facilities for rail wagons, rail shunters, road vehicles, and reusable transport containers
- quarantine facilities for non-compliant transport packages

Requirements for these facilities are provided in the remainder of this section, and a generic, illustrative and conceptual layout for the surface facilities at the GDF is presented in Figure 23. For illustrative purposes, the buildings in red are the waste receipt and handling buildings and construction related buildings are shown in orange.

Figure 23 GDF generic surface layout

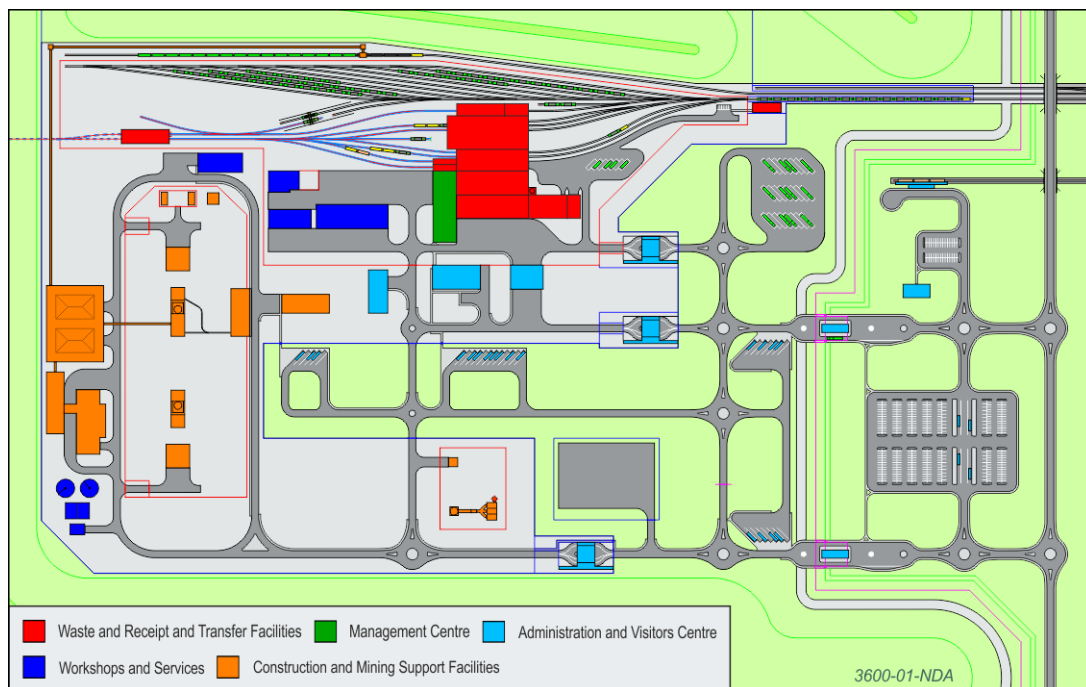

7.4.2 On-site rail

The running rails for main-line rail vehicles will be to the British Standard gauge of 1435mm. All parts of the rail system that will be used by main-line locomotives, in either normal or emergency situations, will be designed to the parameters given in the Permanent

Way Institution's British Railway Track Design Construction and Maintenance standard [39].

All above-ground rail links, both within the GDF site and between the site and the off-site rail system, will comply with the line-side structure clearance requirements for the current track loading gauge (W6A), amended as follows:

- the rail vehicle kinematic envelope will be 150mm larger all round than the W6A loading gauge
- the clearance between the kinematic envelope and line-side structures will be at least 250mm at heights greater than 3415mm above rail level
- the clearance between the kinematic envelope and line-side structures will be at least 830mm at heights less than 3415mm above rail level

There will be a central on-site rail movement control system, with a visual movement display and CCTV links. The on-site rail movement control system will communicate with the adjoining off-site movement control system, and with the rail operator's traffic control centre, in order to receive warning of any variation to timetabled arrival times, and to advise the rail operators when outgoing trains are ready for dispatch. All of this information will be copied to the GDF control centre.

The rail links will be provided with a signalling system that will interface with the off-site signalling system. All road/rail crossings will be protected by automatic systems linked into the signalling system. Remote operation of points will be used wherever it will allow train movements to be carried out more rapidly.

Apart from movements of arriving or departing main-line trains, all other above-ground on-site movements will be carried out by one or more rail shunters that will be able to:

- pull and propel any main-line rail wagons and be fully compatible with them
- operate on the above-ground side of any drift transport system up to the waste receipt building

The rail shunter(s) will be refuelled on-site.

7.4.3 Rail sidings

Sidings on the GDF site will be provided for the following activities:

- receipt of wagons collected from the national railway network
- the breaking-down of trains prior to transfer of wagons to the waste package receipt area
- parking of site shunters
- assembly of trains prior to dispatch onto the national railway network
- segregation of any arriving wagons and/or packages that do not meet the receipt criteria. Packages which are identified as presenting a potential hazard will be held in shielded temporary storage cells within the transport package receipt and transfer facility (Section 9) until the hazard has been resolved. Depending on the detail of the GDF design, this may form part of the segregation area

Sidings will be provided for waste train arrival and departure, the waste package receipt area, trains to remove underground excavation spoil and construction materials trains. The capacity of the sidings will be sufficient to allow for the safe and efficient handling, storage and movement of wagons.

Requirements common to all sidings are that:

- those parts of sidings where wagons will be parked will be straight and level

- the spacing between parallel sidings, where there is a need for staff to walk between trains, will be at least 3m between adjacent edges of outside rails
- the spacing between parallel sidings, where there is no need for staff to walk between trains, will be at least 1.8m (6 feet) between adjacent edges of outside rails
- curves of opposite hand will be separated by an intermediate straight which is longer than the longest rail wagon or locomotive that can use the track
- all points and crossings will be confined to single leads unless there is no alternative
- the sidings will be capable of bearing wagon axle loads up to 25.4t

The layout of rail sidings will provide sufficient clearance between wagons and other features, such as buildings and footpaths. Adequate space will be provided for the receipt, marshalling and dispatch of trains and for the storage of both in-service, out-of-service and failed wagons. The layout will be assessed using a logistics operational research model to ensure satisfactory operation.

The waste arrival/departure sidings will be able to accommodate various sizes of trains consisting of up to 12 main-line wagons carrying transport packages. The maximum overall train length will not exceed 240m. Sufficient facilities will be provided to receive and dispatch this size of train. Access between the waste arrival/departure sidings and the off-site rail network will be controlled by the appropriate rail infrastructure company, in coordination with the GDF rail movement control system.

Although it is proposed to reuse excavated spoil onsite as far as is practical, it is expected that some underground excavation spoil is to be disposed of off-site. Additional rail sidings will be provided to facilitate this in accordance with the general requirements set out above. The spoil sidings will be capable of accommodating trains consisting of up to 20 wagons, with a gross trailing load of up to 1,500t and a locomotive weight of up to 130t. The maximum overall length (including main-line locomotive) will not exceed 290m. Spoil sidings will be located separately from any sidings used by rail wagons carrying waste packages.

Construction materials will be delivered by rail wherever possible; therefore, rail sidings will be provided in accordance with the general requirements set out above, and will be capable of accommodating trains up to the same length and weight as those envisaged for conveying spoil.

7.4.4 On-site roads

Normal standards and Highway Regulations and Codes of Practice will apply to the design of the site roads. The speed limits on roads will be generally 20 mph, but 10 mph on designated Construction Sites or Process Areas. Provision will be made for unrestricted access by emergency vehicles, with the maximum reasonably achievable diversity of routes to any location.

The potential for conflicting vehicle movements will be minimised as far as is reasonably practical. The on-site routes used by waste transport vehicles will be designed such that the STGO Category 3 road vehicle (described in Section 6.2.2) can be accommodated, in terms of both road geometry and adequate pavement strength, together with any other abnormal loads that may be required to be delivered by road during construction. There will be at least 0.5m clearance between the edge of all carriageways and any permanent or temporary obstructions, unless there are overriding requirements for edge treatment or forward visibility.

Parking will be prohibited on any of the circulatory roads at the GDF.

7.4.5 Staff and visitor car parking

Personnel will arrive at the GDF either as pedestrians, cyclists, public transport users or private car occupants on either road or by rail. A car park and bus terminal will be located outside of the GDF boundary fence and shuttle buses will take personnel from the car park bus terminal to the security gatehouse. Personnel will leave the bus and pass through security turnstiles before re-boarding the bus. This will ensure that cars and regular service buses are not driven onto site. Provision will be made for the parking and boarding/alighting of the shuttle buses at the site. Shuttle bus parking areas will be located within the boundary fence, close to the main facilities to allow for dropping off and picking up of personnel during shift changes. Adequate shelter will be provided for personnel waiting for buses.

The parking design will incorporate local design standards. The number of parking spaces will be considered in the Transport Assessment for a specific site. It is anticipated that the number of parking spaces will be controlled, for instance as part of a Travel Plan to minimise the use of car transport. The provision of staff car parking spaces will take into account the requirements of both the construction workforce and the operational workforce. Consideration will be given to an appropriate number of parking spaces to be provided, making due allowance for shift changeovers. Reserved parking provision will be made for disabled persons, both employees and visitors. Parking facilities will be provided for motorcycles and pedal cycles. Provision will be made for visitor car parking and for coach parking for visitors.

Depending on the availability of public transport in the vicinity of the site, a significant proportion of site personnel may travel by public transport, thus reducing the need for on-site parking provision. A railway station has been included in the illustrative designs, located outside of the perimeter fence of the GDF. However, the viability of a rail service for workers has yet to be assessed in light of the numbers regularly commuting to and from the site. Consideration will also be given to transporting construction personnel by bus. If such a plan is adopted, there will be a need for one or more remote car parks with an appropriate number of places, and the requirements for car parking spaces at the GDF will be reduced accordingly. Appropriate provision will be made at the site for pick-up and set-down with adequate shelter.

7.4.6 HGV parking

There will be segregated parking facilities for road vehicles carrying construction materials and transport packages. Each vehicle parking space will be able to accommodate the range of road vehicles anticipated with adequate access. Provision will be made for the segregation of any arriving vehicles and/or packages that do not meet the receipt criteria. Packages that are identified as presenting a potential hazard will be held in quarantine until the hazard has been resolved.

Provision will also be made to accommodate additional road vehicles normally engaged in the waste transport operations for the duration of any interruption to the emplacement of waste.

Provision will be made for parking waste transport vehicles (tractors and/or trailers separately) that are not carrying transport packages, and also HGVs carrying construction materials or for other purposes. Each HGV parking space will be able to accommodate all necessary vehicles with adequate access. The current planning assumption for the illustrative designs is based on an average rate of approximately two waste vehicle arrivals per day. Provision will also be made for light goods vehicle parking wherever required.

Facilities will be provided at the site entrance to permit up to two HGVs to park at any time while documentation is being checked at the gatehouse. In addition, a turning area will be provided outside the site security fence to turn back unauthorised vehicles.

Within the site, a parking area will be provided for HGVs, to accommodate both arrivals and dispatches and also to provide parking for HGVs and trailers not in use. A segregated parking area will be provided for HGVs carrying transport packages, while waiting to enter the waste package transfer facility. There will be a separate bay for HGVs whose transport packages had been accepted on site but are awaiting transfer to the transport container and maintenance facility.

7.4.7 Maintenance

Maintenance of fixed transport infrastructure will be scheduled and carried out at appropriate intervals that do not interfere with the planned delivery and disposal of waste.

Adequate stocks of materials and spare parts will be maintained to allow rapid maintenance of all transport-related equipment. Reliability statistics, procurement and stock-holding will be monitored for each item to ensure that non-availability does not hinder the planned delivery and disposal of waste.

7.4.8 Road and rail vehicle inspection and monitoring

Procedures and facilities will be provided for monitoring those vehicles going off-site that have previously been used for carrying transport packages, or are carrying empty reusable containers. The readily accessible surfaces of the vehicles will be monitored for radiation and contamination, to meet the regulatory limits. Procedures and facilities will be provided to decontaminate accessible surfaces of vehicles when the measured non-fixed contamination levels or the radiation level resulting from any fixed contamination on these surfaces exceed regulatory limits defined in the IAEA Transport Regulations.

After successful completion of monitoring, vehicles will not depart from the site before being issued with a Radiation/Contamination Monitoring Certificate. That certificate will be supplied to the driver/crew, together with the consignor's certificate for any empty transport containers being conveyed. After each vehicle being dispatched has been cleared as having acceptably low contamination levels, it will not pass through any contaminated or potentially contaminated areas before leaving the site.

If a mechanical fault is found during visual inspection or testing such that it cannot be allowed to carry out its journey any package that it may be carrying will be unloaded and the faulty vehicle removed for repair. Loads will be checked visually to ensure that the tie-down system is in good working order and that the load is correctly secured. Where covers are fitted, they will be correctly closed and locked. Normal pre-journey checks will be carried out on the vehicle, covering such items as fuel load, engine oil, engine water and tyre pressures.

Procedures and facilities will be established either on-site or off-site for the maintenance and repair of vehicles, including onsite vehicles. If the off-site option is chosen, procedures and facilities will be established for monitoring and any necessary decontamination of these vehicles before removing them from the site, and also for the safe movement of disabled vehicles on the off-site network.

8 Safety, Security and Safeguards

This section describes the safety requirements, security and safeguard considerations associated with the transport system.

8.1 Safety requirements

The transport system for radioactive waste includes all of the processes, equipment and management arrangements required for the movement of waste packages from a waste consigning site to the GDF including, for example, loading of transport packages onto vehicles, monitoring of transport packages and vehicles, overnight stops and changes in transport mode.

The main legislation dealing specifically with the transport of radioactive waste in the UK is Carriage of Dangerous Goods and Use of Transportable Pressure Equipment Regulations 2009 (CDG) Regulations [40] which regulates the transport of dangerous goods by road and rail. The CDG Regulations implement European agreements concerning the transport of dangerous goods by road or rail. For radioactive materials, the European agreements are based upon the IAEA Regulations for the Safe Transport of Radioactive Material, SSR-6. These Regulations establish international standards of safety which provide an acceptable level of control of the radiation, criticality and thermal hazards to persons, property and the environment that are associated with the transport of radioactive material.

The most hazardous materials, including HHGW, and some types of LHGW are planned to be transported in reusable Type B transport containers made from high-integrity materials that provide containment of radioactive materials and shielding from radiation even under transport accident conditions (severe impact, fire and immersion in water). Less hazardous LHGW are assumed to be packaged in industrial packages, typically large steel or concrete boxes which are designed to be both a transport and disposal package.

At this stage designs have been developed for two types of reusable Type B transport containers to transport waste to the GDF: the SWTC family of design will be used to transport ILW/LLW and DNLEU; and DCTCs will be used for the transport of HLW/SF, Pu and HEU.

8.2 Security

Security involves the various measures to guard against the consequences of intentional malicious acts. The ONR's Civil Nuclear Security (CNS) Programme, is responsible for the regulation of security during transport for material that falls under the requirements of the NISR. These Regulations define nuclear material and whether the material is class I/II, III or IV. The class that the material falls into depends, in part, on the total mass of material being transported in the road convoy, on the train or on the ship (as the case may be). With regard to the transport of Category I/II or Category III nuclear material, NISR lay down requirements to use approved carriers only, the duties of approved carriers and the provision of a security statement and transport plan for approval by ONR. The security of the transport of radioactive materials that are not Category I/II or Category III nuclear materials is regulated by ONR under the CDG Regulations. It is assumed that the provisions of NISR will apply to most operations for the transport of radioactive waste to the GDF.

In accordance with the ONR guidance document [41], which provides guidance on avoiding the disclosure of information that could assist a person or group planning theft or sabotage, this report does not contain information on the physical security arrangements assumed or planned in order for the GDF to protect nuclear and other radioactive materials and its

related factors. Transport of nuclear material to and within the GDF site will be described in a transport security statement and an associated transport plan, also approved by ONR. ONR will approve carriers and transport plans where the movement of nuclear material to the GDF is involved. Civil nuclear transport arrangements must have a shipment-specific security plan approved by ONR, and any proposed changes to security plans must also be approved in advance by ONR. The security plan will provide details of security management arrangements, policing and guarding, and describe in detail the security measures and arrangements for managing and reporting incidents.

Liaison with ONR and national rail companies will take place at all stages of development of the transport system. In this way, all suitable security measures will be included in transport plans for the GDF for all stages of operation. The intent is to avoid the need to retrofit security measures once implementation is underway and this will enable regulators to make an early judgement on the most appropriate measures for any transport method.

8.3 Safeguards

The UK is a signatory of the Nuclear Non-Proliferation Treaty, and is committed to use nuclear materials from its civil nuclear programmes for peaceful uses. The verification of Treaty compliance is carried out by inspectors from the IAEA, under its safeguards agreements with member states [42]. Safeguards are technical and political measures that deter and ultimately detect the diversion of certain materials from civilian use to non-peaceful uses.

The transport and disposal of any nuclear material subject to safeguards in the GDF will require safeguards verification. This verification is to provide independent assurance that nuclear material is not being diverted from its declared disposal and that the system of nuclear material accountancy and control is acceptable. The UK formally reports to Euratom through ONR Safeguards on, the stocks, transformation and movements of safeguarded materials. Euratom in turn, conducts comprehensive verification exercises on the declarations, and reports its findings to the IAEA under the trilateral agreement. Under these arrangements, site visits to inspect transport dispatching organisations and facilities, and the GDF, will be routinely undertaken by Euratom inspectors to physically verify the material stocks and their associated records, to ensure nuclear materials are not diverted to other purposes. Under a separate agreement between the UK and the IAEA, the latter also has the right to conduct safeguard inspections at a small number of nominated facilities.

The design and operation of the transport system will incorporate sufficient safeguard measures to give assurance on the prevention of diversion. These measures will include detailed nuclear material accountancy (NMA) at dispatching sites, and on receipt at the GDF, so that those radioactive materials covered by safeguards are always accounted for and their place of residency is known. Such measures will be subject to continual monitoring and inspection by Euratom inspectors.

More detail about the application of safeguards to the GDF can be found in [43].

8.4 Emergency arrangements

The possibility of an accident resulting in radiation exposures of workers and the general public from transporting radioactive waste to the GDF can never be entirely eliminated. Emergency arrangements are required under the IAEA Transport Regulations.

Emergency arrangements will therefore be in place to ensure that a suitable response is provided by emergency services, carriers, consignors and local and national government agencies in the event of an emergency involving the transport of radioactive waste.

RWM plans to become a member of the RADS SAFE scheme in order to support the emergency arrangements for the transport of radioactive waste to the GDF. RADS SAFE is a mutual assurance scheme formed in the late 1990s by a group of organisations in the UK nuclear industry that transport radioactive material. RADS SAFE was established to respond to transport accidents involving radioactive materials belonging to a member of the scheme with the purpose of 'providing expert assistance to the emergency services following an incident involving the transport of radioactive material'.

RWM will become a member of the RADS SAFE scheme at a time that is appropriate to ensure it is fit and ready to transport radioactive material to the GDF. It is not appropriate for RWM to join RADS SAFE at this stage because there is no licensed site or trained staff to provide mutual assistance to other members of the scheme and the emergency services that call on RADS SAFE for assistance.

RADS SAFE covers England, Scotland and Wales, but is restricted to signatories of the RADS SAFE contract. The scope covers events involving the transport of radioactive material, but excludes events on licensed nuclear sites. Typical consignments already covered by the RADS SAFE scheme include fuel flasks, UF₆ transports, radiopharmaceuticals, radioactive waste and some Ministry of Defence shipments.

There are four key principles of the RADS SAFE scheme. Firstly, general advice is to be provided as soon as possible to the emergency services. Secondly, the scheme provides a guaranteed response. Thirdly, the scheme provides a framework for media response. Finally, the scheme ensures that there is ownership of any necessary clean-up activities.

The response is broken down into three levels:

- Level 1 – notification/communication service: provision of generic radiological protection advice by the Civil Nuclear Constabulary's Force Communications Centre (FCC)
- Level 2 – provision of radiological advice/support at the incident scene by a level 2 responding site
- Level 3 – consignment owner response and clean-up. This response is underpinned by RADS SAFE's defined standards covering response, personnel, equipment, performance, notification route and reporting procedures

The 'RADS SAFE Plan' contains the operational details of the scheme, including notification chains, action lists, an advice flow sheet, and details of the appropriate consignment placard. The scheme is tested through an annual programme of emergency exercises that includes both desktop and full-scope exercises.

RADS SAFE provides information to the public regarding the transport of radioactive material. Supporting the information to the public, awareness courses and information are provided mainly for the emergency services covering risk assessments, presentations and other supporting information through RADS SAFE's website.

The RADS SAFE scheme, working through its mutual support framework, ensures that adequate emergency arrangements are in place for the transport of radioactive materials in the UK. It is the intention that RADS SAFE will be applied to all the road and rail transport of radioactive waste for which RWM is responsible.

9 Implications of a Change to the 2013 Derived Inventory

The number of transport movements, required for both transport packages and materials for construction, are sensitive to a number of factors such as geological environment, modes of transport, location for geological disposal, and other factors such as HGV and freight train payloads, operating hours and non-working time.

The generic transport system designs presented in this report have been based on the 2013 Derived Inventory. However, there are sources of uncertainty in the eventual inventory for disposal that are also covered by RWM's work programme. These include uncertainties in the volumes and radionuclide contents of the currently identified wastes and materials in the 2013 Derived Inventory and uncertainties in scenarios for the future operation of nuclear plants and other facilities that produce these wastes and materials.

A range of scenarios have been developed for the inventory for disposal in order to evaluate the implications of these uncertainties for a geological disposal programme. RWM wants to be able to demonstrate that the GDF can be developed to dispose of an inventory safely and securely. These scenarios also provide visibility to local communities of what transport requirements might be involved in hosting the GDF.

The effect that a change of the inventory would have on the generic transport system design is discussed below.

9.1 GDF transport movements

Changes to the inventory for disposal would potentially affect the number of packages and hence transport movements required for disposal. The change in waste package numbers requiring transport to the GDF would either increase or decrease the annual number of transports and/or duration of transport operations required to transport all of the waste to the GDF. This will potentially change the number of transport containers required to manage a transport system.

The inventory for disposal and number of waste packages are some of the key drivers in the number of disposal vault and tunnels required at the GDF. Should the underground requirements change, this would have an effect on the volume of construction materials and excavated spoil requiring transport to and from the GDF. The extent to which these volumes change will also be dependent upon the geological environment and size of excavations.

A change in the inventory for disposal may also affect the duration of the operational programme, and impact on the duration of time over which transport movements will be required.

9.2 Additional facilities

The generic transport design has been based on the current illustrative design for the 2013 Derived Inventory. However, it is recognised that there could be a number of additional facilities that could be developed to support geological disposal and there is a potential for them to be located adjacent to the GDF, subject to discussions and acceptance by the local community. If any of these facilities are built within or adjacent to the GDF, there may be consequential effects on the number of transport movements.

If the GDF were to include additional facilities, staffing levels and hence trip generation may increase. There would also be a consequential increase in the number of construction-related transport movements during both commissioning and decommissioning of these facilities. The total number of transport movements associated with these facilities is not

expected to be significant compared to the number of movements required for GDF construction materials, spoil and backfill, although the facilities would be expected to be constructed and later demolished over relatively short periods.

9.3 Other factors

In planning/scheduling transport movements, a number of assumptions have been made, for example the number of wagons per train, the duration of the main activities, throughput rates for waste packages at the GDF. All these carry some degree of uncertainty at this stage.

All movements of spoil, backfill and construction material by rail will be dependent on the payload (number of wagons multiplied by wagon payload) per freight train. Train length is governed by route restrictions on trailing weight and trailing length and length restrictions imposed by railheads and sidings. Clearly, the payload of a train will directly influence the number of train trips, and longer train lengths may only meet the trailing weight restrictions if the wagon payload is reduced.

Similarly, the estimated number of transport movements depends on other assumptions such as HGV payloads for a range of material types, operating hours and non-working periods. Some of these factors will be within the control of the construction contractors or the GDF operator and will be varied in order to optimise the transport operations.

10 Way Forward

This report summarises the generic transport system designs and describes the operations required to ensure safe and efficient transport of waste packages through the public domain to the GDF. The report describes both the requirements and potential logistics associated with the transport operation based on road or rail scenarios.

The transport solutions described in this report have been prepared to allow us to undertake the associated assessments of safety, environmental, social and economic impacts and assessments of the costs to develop the facility.

The designs give an appreciation of the transport system required for moving radioactive waste from the main waste consigning sites and to help stakeholders to understand the potential work ahead. This update has been prepared in order to quantify the impact of adopting design changes and enhancements within the design of the transport system, such that up to date designs are available as an input to support the siting process. The current transport system design is based on technology that is available today both in terms of how waste is being conditioned on waste consigning sites and on how it can be handled and transported to the GDF. It is expected that the system design will evolve to suit both waste packaging solutions and transport solutions as they become more mature.

The process for implementing Geological Disposal is shown in Figure 24.

Figure 24 Diagram showing process moving forward

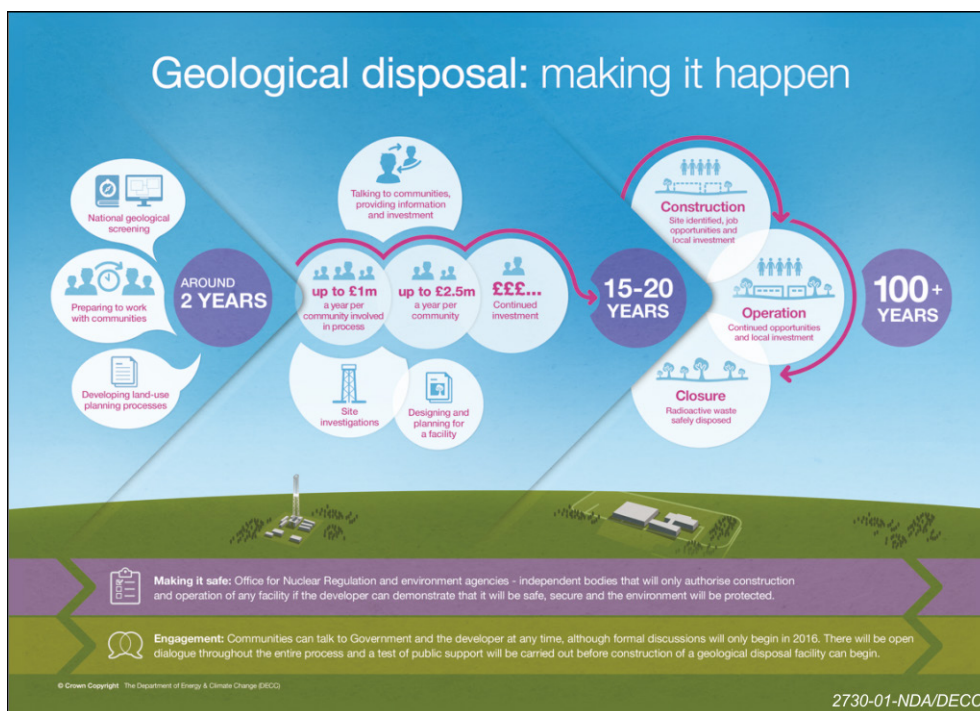

As the process above progresses, details of a geological environment and site-specific characteristics will become available that will allow detailed analysis of local infrastructure so as to identify suitable transport opportunities. Until such time as more specific information becomes available, the approach that will continue to be taken is to define a number of generic geological disposal concepts applied to typical, potentially suitable UK geological environments. The DSSC documents will initially describe generic requirements, reflecting the fact that a site and a disposal concept have yet to be identified. They will be periodically updated, for example to respond to changes in regulations or the

inventory for disposal, and to respond to learning from undertaking assessments and further research. The DSS Part B, in particular, will evolve from generic to site-specific requirements as site-specific information becomes available at the more detailed level and as issues that are recognised today are resolved. Some issues are of a general nature and faced by other countries in implementing geological disposal, and some are UK-specific.

As the process progresses, there will also be a requirement to maintain and periodically update the generic designs and this report to take account of future requirements and to support both wider stakeholder engagement and the waste packaging assessment process. It is expected that these generic designs will continue to be required and updated as the designs move forward through the process from their current illustrative status through the conceptual and preliminary design stages and until a detailed design for the GDF at a specific site is developed.

References

- 1 Radioactive Waste Management, *Geological Disposal: Overview of the Generic Disposal System Safety Case*, DSSC/101/01, 2016.
- 2 Department of Energy and Climate Change, *Implementing Geological Disposal - A framework for the long term management of higher activity waste*, URN 14D/235, July 2014.
- 3 Radioactive Waste Management, *Geological Disposal: Technical Background to the generic Disposal System Safety Case*, DSSC/421/01, 2016.
- 4 NDA, *2013 UK Radioactive Waste Inventory: Scope and Conventions*, NDA/ST/STY(14)0008.
- 5 Radioactive Waste Management, *Geological Disposal: Generic Disposal Facility Designs*, DSSC/412/01, 2016.
- 6 Radioactive Waste Management, *Geological Disposal: Disposal System Part A: High Level Requirements*, DSSC/401/01, 2016.
- 7 Radioactive Waste Management, *Geological Disposal: Disposal System Part B: Technical Requirements*, DSSC/402/01, 2016.
- 8 Radioactive Waste Management, *Disposal System Safety Case: Data Report*, DSSC/422/01, 2016.
- 9 Radioactive Waste Management, *Geological Disposal: Design Status Report*, NDA/RWM/141, March 2016.
- 10 Radioactive Waste Management, *Geological Disposal: Science and Technology Plan*, NDA/RWM/121, May 2016.
- 11 HM Government Cabinet Office, *Government Construction Strategy*, May 2011.
- 12 NDA, *Geological Disposal: RWMD Building Information Management Strategy and Implementation Plan*, LL18078816, December 2012.
- 13 Office of Public Sector Information, *The Town and Country Planning (Development Management Procedure) (England) Order 2010*, SI 2010 No. 2184, 2010.
- 14 Office of Public Sector Information, *The Infrastructure Planning (Applications: Prescribed Forms and Procedure) Regulations 2009*, SI 2009 No. 2264, 2009.
- 15 Department for Communities and Local Government, *National Planning Policy Framework*, ISBN 978-1-4098-3413-7, 2012.
- 16 Radioactive Waste Management, *Geological Disposal: Generic Transport Safety Case - Main Report*, DSSC/201/01, 2016.
- 17 NDA, *Geological Disposal: Generic Transport System Designs*, NDA/RWMD/046, December 2010.
- 18 Radioactive Waste Management, *Geological Disposal: Generic Specification for waste packages containing high heat generating waste*, WPS/240/01, February 2016.
- 19 Radioactive Waste Management, *Geological Disposal: Generic Specification for waste packages containing DNLEU*, WPS/230/01, December 2015.

-
- 20 NDA, *Geological Disposal: Generic Specification for waste packages containing LHW*, NDA/RWMD/068, August 2012.
 - 21 Radioactive Waste Management, *Geological Disposal: Waste packages and the assessment of their disposability*, DSSC/441/01, 2016.
 - 22 Radioactive Waste Management, *Transport Package Safety Report*, DSSC/302/01, December 2016.
 - 23 NDA, *Transport & Logistics Topic Strategy*, March 2013.
 - 24 United Kingdom Nirex Ltd, *Generic Repository Studies: Generic Repository Design*, Nirex Report N/077, 2005.
 - 25 United Kingdom Nirex Ltd, *Outline Design for a Reference Repository, Concept for UK High Level Waste / Spent Fuel*, Technical Note, September 2005.
 - 26 International Atomic Energy Agency, *Regulations for the Safe Transport of Radioactive Material*, 2012 Edition Safety Requirements, SSR-6, 2012.
 - 27 International Nuclear Services, *Summary Report: Concept Design of the Disposal Container Transport Container (DCTC)*, INS ENG R 15 146 Rev 3, April 2016.
 - 28 International Nuclear Services, *Compatibility Assessment of the Disposal Container Transport Container Design against the 2013 Inventory*, INS ENG R 15 147 Rev 2, June 2016.
 - 29 NDA, *Geological Disposal: Development of manpower and skills data*, NDA/RWMD/076, May 2011.
 - 30 United Kingdom Nirex Ltd, *Design of a Rail Wagon for Transporting all Nirex Packages*, LL11990931, 1994.
 - 31 European Union, Council Directive 96/53/EC of 25 July 1996, *Laying down for certain road vehicles circulating within the Community the maximum authorised dimensions in national and international traffic and the maximum authorised weights in international traffic*, Official Journal of the European Union, L 235.
 - 32 Office of Public Sector Information, *The Road Vehicles (Construction and Use) Regulations 1986* (as amended).
 - 33 Office of Public Sector Information, *The Road Vehicles (Authorisation of Special Types) (General) Order 2003*, SI No. 1998.
 - 34 ESDAL, *Electronic Service Delivery for Abnormal Loads*, www.esdal.com
 - 35 King Vehicle Engineering, *Road Transport Vehicles Compatible with the Generic Transport System design*, P12-400 T50012, 2017.
 - 36 Office of Public Sector Information, *The Road Vehicles (Authorised Weight) Regulations 1998*, SI No 3111, as amended by SI 2000, No 3224 and SI 2001 No 1125.
 - 37 Office of Public Sector Information, *Nuclear Industry Security Regulations 2003 (as amended 2006)*, SI No 2815 2013 edition.
 - 38 Office of Public Sector Information, *The Ionising Radiations Regulations 1999*, SI No 3232.
 - 39 Permanent Way Institution, *British Railway Track - Design, Construction and Maintenance*, seventh edition.

-
- 40 Office of Public Sector Information, *The Carriage of Dangerous Goods and Use of Transportable Pressure Equipment Regulations 2009*, SI 2009, No 1348 (as amended).
 - 41 Office for Nuclear Regulation, 2014, *Finding a Balance – Guidance on the Sensitivity of Nuclear Related Information and its Disclosure*, Version 3, April 2014.
 - 42 International Atomic Energy Authority, *agreement between the United Kingdom of Great Britain and Northern Ireland, the European Atomic Energy Community and the International Atomic Energy Agency for the Application of Safeguards in the United Kingdom of Great Britain and Northern Ireland in Connection with the Treaty on the Non-Proliferation of Nuclear Weapons (with Protocol)*, INFCIRC/263, 1976.
 - 43 Radioactive Waste Management, *The Application of Nuclear Safeguards to a UK Geological Disposal Facility*, February 2015.

Glossary

A glossary of terms specific to the generic DSSC can be found in the Technical Background.

Appendix A – Waste volumes for disposal

Waste category	Waste type	2013 Derived Inventory	
		Volume of packaged waste (m ³)	Conditioned waste volume (m ³)
LHGW	Legacy LLW	11,800	11,100
	Legacy ILW	415,000	327,600
	DNLEU UILW	13,600	11,200
	DNLEU SILW	203,800	149,200
	NNB ILW	41,000	25,000
HHGW	Legacy HLW	9,300	1,400
	Legacy SF	14,800	3,400
	Pu / HEU	3,100	869
	MOX SF	11,900	594
	NNB SF	39,400	5,900

Appendix B – Waste package numbers

This section describes the various waste package types, their dimensions and the number of packages for each waste type within the 2013 Derived Inventory. There is also information on the characteristics of each of the package types.

LHGW (UILW) Waste Packages

Waste package type	Total number of disposal units ⁷
Legacy waste packages	
Stillages of 500 litre drums	22,900
Stillages of enhanced 500 litre drums (precast)	223
Stillages of enhanced 500 litre drums (basket)	6,530
Total disposal stillages of four 500 litre drums	29,700
3 cubic metre drums	563
3 cubic metre box (side lifting)	4770
3 cubic metre box (corner lifting)	402
3 cubic metre Sellafield box (i.e. single skinned)	54,300
3 cubic metre Enhanced Sellafield box (i.e. double skinned)	16,300
MBGWS	1,500
NNB waste packages	
3 cubic metre box (round corners)	960
3 cubic metre drums	7,270
Total UILW	116,000

⁷ A UILW disposal unit consists of either one 3 cubic metre box, one 3 cubic metre drum or four 500 litre drums contained in a stillage.

LHGW (SILW) waste packages

Waste package type	Total number of disposal units
Legacy waste packages	
6 cubic metre boxes	426
4 metre boxes (no lining)	2,180
4 metre boxes (100mm concrete lining)	1,190
4 metre boxes (200mm concrete lining)	399
2 metre boxes (100mm concrete lining)	75
500 litre robust shielded drum	1,236
3 cubic metre robust shielded box	1,040
NNB waste packages	
4 metre boxes (100mm concrete lining)	60
1 cubic metre concrete drum	6,840
500 litre concrete drum	3,240
Total SILW	16,700

LHGW (LLW) waste packages

Waste package type	Total number of disposal units
4 metre boxes (no lining)	584
Stillages of LLW 500 litre drums	54
Total LLW	638

HHGW package types and numbers

Waste type	Total number of disposal units
HLW	2,400
AGR SF	2,190
PWR SF	572
Magnox	836
PFR	19
MOX	2,700
NNB SF	8,940
Total HHGW	17,700

Number of plutonium and uranium disposal units

Waste type	Waste package type	Total number of disposal units
Pu	Disposal container (similar to HLW/SF)	196
HEU	Disposal container (similar to HLW/SF)	780
DNLEU	Disposal stillages of 500 litre drums	5,940
	Transport and Disposal Container	7,250

Total number of disposal units

Inventory for disposal	Total number of disposal units
2013 Derived Inventory	164,900

Appendix C – Materials and Personnel Transport Movements

This section describes the forecast volumes of material to be transported alongside estimate of the associated number of vehicle movements. There is also information on the number and type of personnel movements. These transport movements have been forecast based upon the forecast quantities of materials and personnel to be transport to and from the site, the rates of transport required and the capacity/payload of vehicles that may be used.

Table C1 Surface construction material movement summary

Year	Total Trucks per year (vehicles)		
	Higher strength rock	Lower strength sedimentary rock	Evaporite rock
1	100	100	200
2	-	100	100
3	200	150	200
4	200	200	1,500
5	-	350	700
6	200	1,400	450
7	700	550	700
8	2,250	400	10
9	500	600	150
10	400	10	-
11	200	100	-
Total*	4,750	4,000	4,000

*Figures are rounded

Table C2 Underground construction material movements for higher strength rock (note values have been rounded)

Material	Volume		Tonnage		Trucks per year (peak)	OR Trains per year (peak)
	Total	Peak year	Total	Peak year		
Concrete	460,000m ³	22,000m ³	700,000	33,000	1,100	25
Shotcrete	300,000m ³	6,000m ³	460,000	9,000	300	7
Rockbolts	180,000 bolts	10,000 bolts	1,900	100	10	1
Steel	N/A		4,100	700	90	1

Table C3 Underground construction material movements for lower strength sedimentary rock (note values have been rounded)

Material	Volume		Tonnage		Trucks per year (peak)	OR Trains per year (peak)
	Total	Peak year	Total	Peak year		
Concrete	890,000m ³	50,000m ³	1,350,000	75,000	2,500	60
Shotcrete	1,200,000 m ³	36,000m ³	1,800,000	55,000	1,750	40
Rockbolts	800,000 bolts	9,000 bolts	5,000	140	10	1
Steel	N/A		5,500	1,700	20	1

Table C4 Underground construction material movements for evaporite rock
(note values have been rounded)

Material	Volume		Tonnage		Trucks per year (peak)	OR Trains per year (peak)
	Total	Peak Year	Total	Peak year		
Concrete	360,000m ³	77,000m ³	540,000	116,000	3,900	90
Shotcrete	550m ³	300m ³	800	400	15	1
Rockbolts	830,000 bolts	34,000 bolts	9,700	400	35	1
Steel	N/A		5,000	400	45	1

Table C5 Peak personnel trips per day

Mode ⁸	%	Construction		Operation	
		People	Vehicles	People	Vehicles
Public transport	17%	170	9	85	5
Car	67%	670	603	335	302
Walk/Cycle	15%	150	150	75	75
Other	1%	10	10	5	5
Total	100%	1,000	772	500	387

⁸ The mode of transport used by personnel will be highly site-specific, depending upon the location of the site relative to the relevant populations and the availability of transport modes. For the purposes of this assessment, data from the 2011 Census on Method of Travel to Work in England and Wales (excluding work from home trips) has been used to derive a modal split.

Appendix D – Transport Conveyance Dimensioned Drawings

Figure 25 Rail wagon

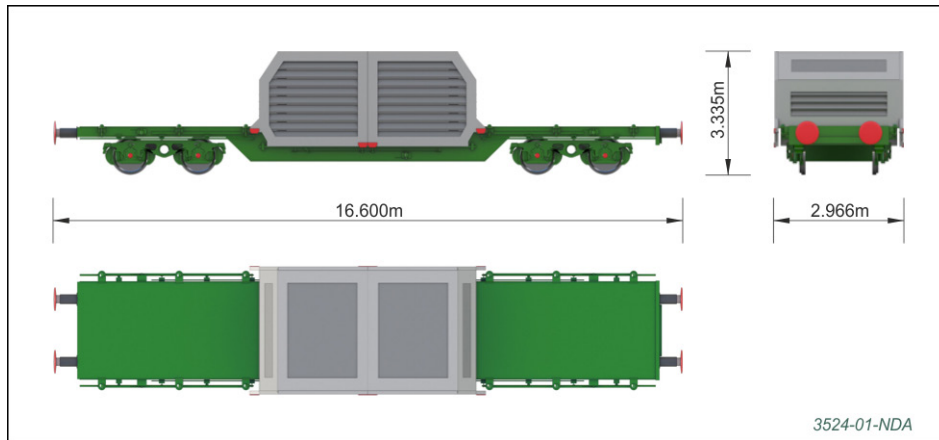

Figure 26 GC&U/STGO Category 1 vehicle

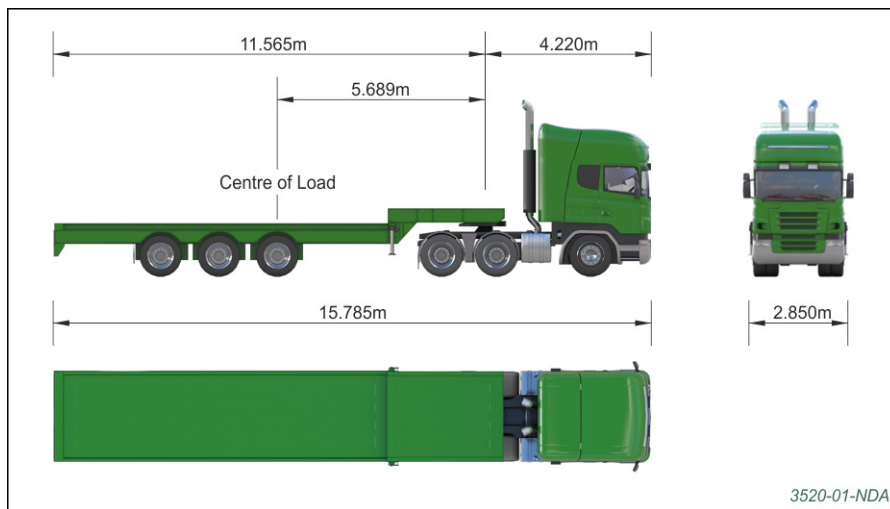

Figure 27 STGO Category 3 vehicle

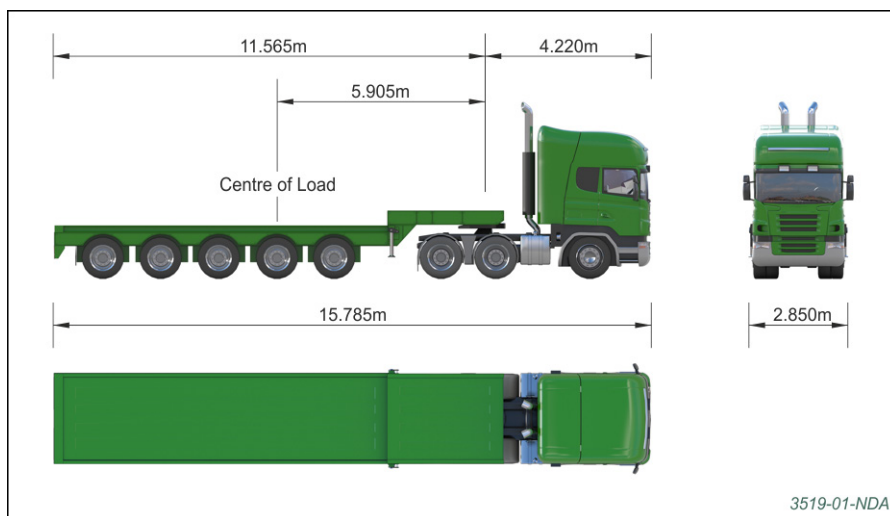

Figure 28 Open box wagon

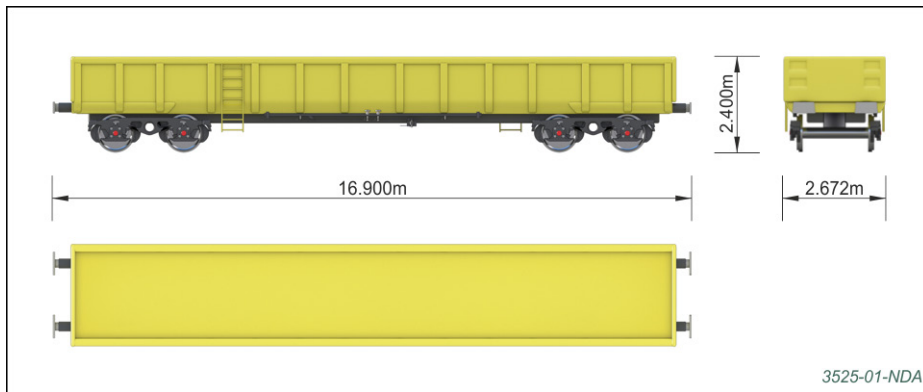

Figure 29 Open-top box wagon

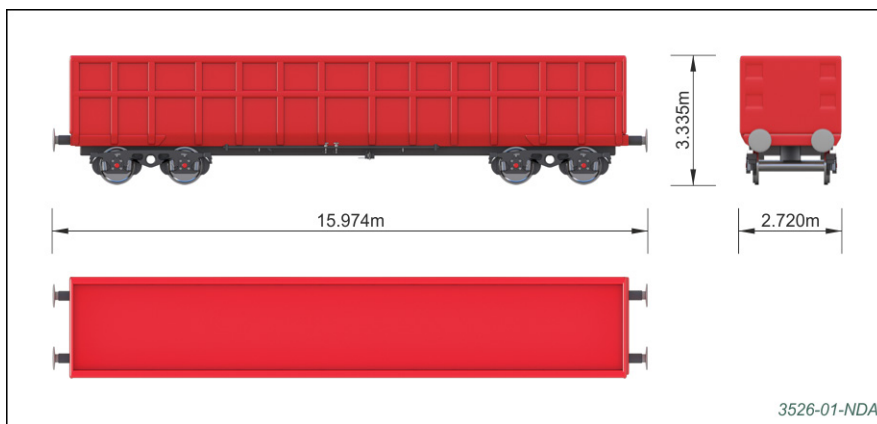

Figure 30 Flat wagon

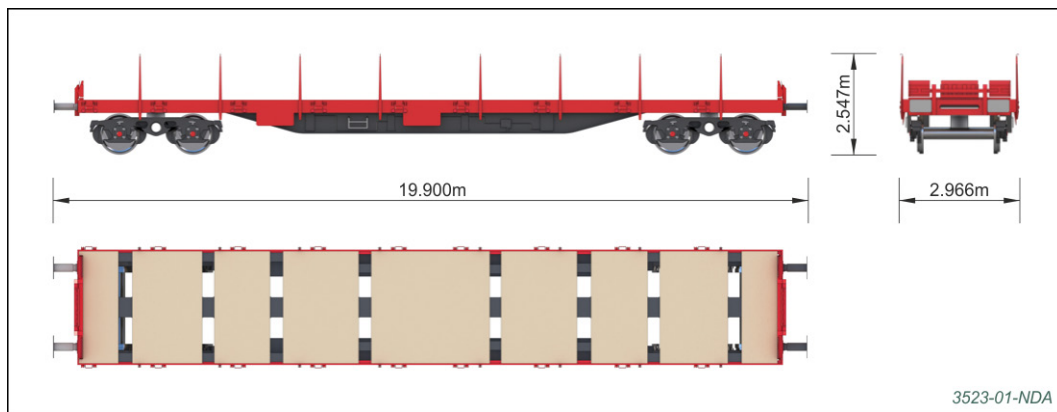

Figure 31 Commercial tipper truck

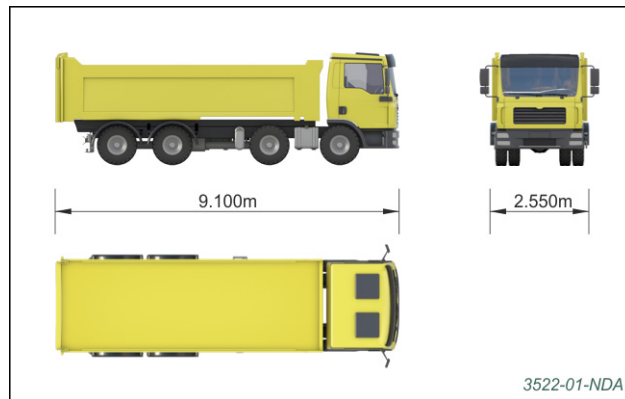
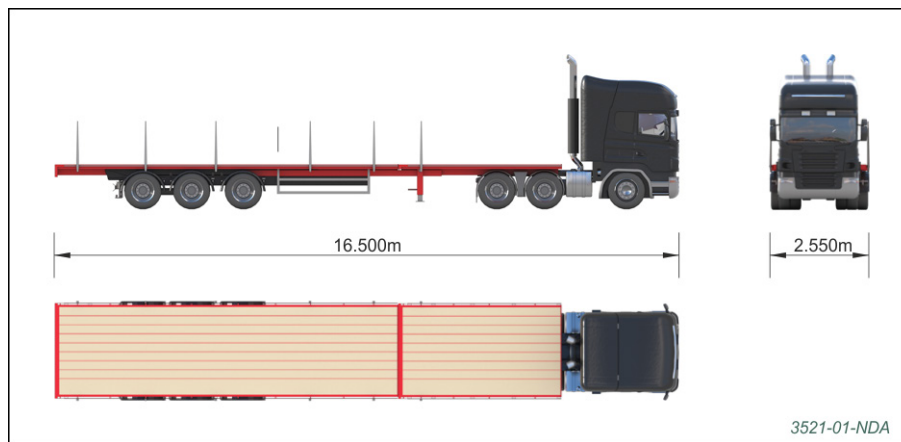

Figure 32 Six-axle articulated vehicle





Certificate No LRQ 4008580

Radioactive Waste Management Limited
Building 587
Curie Avenue
Harwell Oxford
Didcot
Oxfordshire OX11 0RH

t +44 (0)1925 802820

f +44 (0)1925 802932

w www.gov.uk/rwm

© Nuclear Decommissioning Authority 2016