



Defence  
Safety  
Authority

## **Service Inquiry**

Yak-52 G-YAKB

8 Jul 16

Defence Safety  
Authority

Left Intentionally Blank

**PART 1.1 – COVERING NOTE**

20170425-SI\_Part\_1.1\_Covering Note-OS-SI

25 Apr 17

DG DSA

**SERVICE INQUIRY INVESTIGATION INTO ACCIDENT INVOLVING Yak-52 G-YAKB on 8 Jul 16.**

1. The Service Inquiry Panel assembled in MOD Main Building, on the 14 Jul 16 by order of the DG DSA for the purpose of investigating the accident involving Yak-52 G-YAKB on 8 Jul 16 and to make recommendations in order to prevent recurrence. The Panel has concluded its inquiries and submits the provisional report for the Convening Authority's consideration.

**PRESIDENT**

██████████  
Cdr RN  
President  
G-YAKB SI

**MEMBERS**

██████████  
Squadron Leader  
Engineering Member  
G-YAKB SI

██████████  
Squadron Leader  
Aircrew Member  
G-YAKB SI

2. The following inquiry papers are enclosed:

- Part 1 (The Report)
- Part 1.1 Covering Note
- Part 1.2 Convening Orders & TORs
- Part 1.3 Narrative of Events
- Part 1.4 Findings
- Part 1.5 Recommendations
- Part 1.6 Convening Authority Comments

- Part 2 (The Record of Proceedings)
- Part 2.1 Diary of Events
- Part 2.2 List of Witnesses
- Part 2.3 Witnesses Statements
- Part 2.4 List of Attendees
- Part 2.5 List of Exhibits
- Part 2.6 Exhibits
- Part 2.7 List of Annexes

~~OFFICIAL SENSITIVE~~

Part 2.8 Annexes  
Part 2.9 Schedule of Matters Not Germane to the Inquiry  
Part 2.10 Master Schedule

1.1 - 2

~~OFFICIAL SENSITIVE~~

~~OFFICIAL SENSITIVE~~

**PART 1.2**

**Convening Order including Terms of Reference**

**Glossary**





Defence  
Safety  
Authority

## Service Inquiry Convening Order

27 Jul 16

SI President  
SI Members

Hd Defence AIB  
DSA Legad

Copy to:

PS/SofS  
MA/Min(AF)  
PS/Min(DP)  
PS/Min(DPV)  
PS/PUS  
DPSO/CDS  
MA/VCDS

NA/CNS  
MA/CGS  
PSO/CAS  
MA/Comd JFC  
PSO/DComOps  
MA/COS Ops  
MA/Dir MAA

PSO/Comd AWC  
AWC CTP  
QINETIQ  
Chief Inspector AAIB  
Dir DDC

### DSA DG/SI/01/16 – CONVENING ORDER FOR THE SERVICE INQUIRY INTO THE AIRCRAFT ACCIDENT INVOLVING YAK 52, CALLSIGN 'G-YAKB' ON 8 JUL 16 AT 1033(Z+1) CLOSE TO BOSCOMBE DOWN

1. A Service Inquiry (SI) is to be held under Section 343 of Armed Forces Act 2006 and in accordance with JSP 832 – Guide to Service Inquiries (Issue 1.0 Oct 08).
2. The purpose of this SI is to investigate the circumstances surrounding the subject aircraft accident and to make recommendations in order to prevent recurrence.
3. The SI Panel will formally convene at Ministry of Defence Main Building, Whitehall, London at 1400(Z+1) on Thu 14 Jul 16.
4. The SI Panel comprises:
 

President: [REDACTED] Cdr [REDACTED] RN

Members: Ops Member – [REDACTED] Sqn Ldr [REDACTED] RAF  
Eng Member – [REDACTED] Sqn Ldr [REDACTED] RAF
5. The legal advisor to the SI is Wg Cdr [REDACTED] (DSA-MAA Legad) and technical investigation/inquiry assistance is to be provided by the Defence Accident Investigation Branch (Defence AIB).
6. The SI is to investigate and report on the facts relating to the matters specified in its Terms of Reference (TOR) and otherwise to comply with those TOR (at Annex). It is to record all evidence and express opinions as directed in the TOR.
7. Attendance at the SI by advisors/observers is limited to the following:

**Head Defence AIB – Unrestricted Attendance.**



**OFFICIAL SENSITIVE**

**Defence AIB investigators in their capacity as advisors to the SI Panel – Unrestricted Attendance<sup>1</sup>.**

**[REDACTED], RAFCAM HF Psychologist – Unrestricted Attendance.**

**AAIB Accident Investigators – Attendance to be determined by the SI President.**

8. The SI Panel will work initially from the Defence AIB facilities at Farnborough. Permanent working accommodation, equipment and assistance suitable for the nature and duration of the SI will be requested by the SI President in due course.
9. Reasonable costs will be borne by DG DSA under UIN D0456A.

*Original Signed*

R F Garwood  
AM  
DG DSA – Convening Authority

Annex:

- A. Terms of Reference for the SI into aircraft occurrence involving YAK 52, G-YAKB on 8 Jul 16 in Wiltshire, England.

---

<sup>1</sup> Dep Hd, SO1 Air and investigators as authorised by Hd Defence AIB.

**TERMS OF REFERENCE FOR THE SERVICE INQUIRY INTO THE AIRCRAFT ACCIDENT INVOLVING YAK 52, CALLSIGN 'G-YAKB' ON 8 Jul 16 AT 1033(Z+1) IN WILTSHIRE, ENGLAND.**

1. As the nominated Inquiry Panel for the subject SI, you are to:
  - a. Investigate and, if possible, determine the cause of the occurrence, together with any contributory, aggravating and other factors and observations.
  - b. Ascertain whether the personnel (Service and civilian) were acting in the course of their duties.
  - c. Examine what policies, orders and instructions were applicable and whether they were complied with.
  - d. Establish the level of training, relevant competencies, qualifications and currency of the individuals involved in the incident.
  - e. Identify if the levels of planning and preparation met the activities' objectives.
  - f. Review the levels of authority and supervision covering the task during which the incident occurred.
  - g. Investigate and comment on relevant fatigue implications of an individual's activities prior to the matter under investigation.
  - h. Determine the state of serviceability of relevant equipment.
  - i. Determine any equipment deficiencies.
  - j. Ascertain if aircrew escape and survival facilities and equipment assemblies were fully utilised and functioned correctly.
  - k. Determine whether Aircraft Post-Occurrence Management procedures were adequate and complied with.
  - l. Determine and comment on any broader organisational and/or resource factors including the use of outsourced civilian aircraft for test pilot training.
  - m. Determine and comment on the Duty Holding construct for ETPS.
  - n. Determine the level of injuries sustained and the potential for later disability.
  - o. Ascertain value of loss/damage to the Service and extent of loss/damage to civilian property.
  - p. Make appropriate recommendations to DG DSA.
  
2. The Air Accident Investigation Branch (AAIB) will be conducting a statutory investigation in accordance with the Civil Aviation Act 1982 and The Civil Aviation (Investigation of Air Accidents and Incidents) Regulations 1996. The SI is to proceed in parallel, sharing pertinent information wherever possible whilst acknowledging the separate legal frameworks. The President is to maintain close liaison with AAIB wherever possible to ensure best use of resources and avoid duplication of effort whilst still obtaining evidence in accordance with the Service Inquiry Regulations and the procedures laid down in JSP 832. In the event of conflict, Hd Defence AIB and DSA Legal Advisor are to be consulted.
  
3. During the course of your investigations, should you identify a potential conflict of interest between the Convening Authority and the Inquiry, you are to pause work and consult DG DSA. Following that advice it may be necessary to reconvene reporting directly to MOD PUS.



**OFFICIAL SENSITIVE**

4. You are to ensure that any material provided to the Inquiry by any foreign state, is properly identified as such, and is marked and handled in accordance with MOD security guidance. This material continues to belong to those nations throughout the SI process. Before the SI report is released to a third party, authorization should be sought from the relevant authorities in those nations to release, whether in full or redacted form, any of their material included in the SI report, or amongst the documents supporting it. The relevant NATO European Policy (NEP) or International Policy and Plans (IPP) team should be informed early when dealing with any foreign state material.

**OFFICIAL SENSITIVE**

**GLOSSARY**

<b>Acronym/ Abbreviation</b>	<b>Explanation</b>
AAIB	Aircraft Accident Investigation Branch of the Department for Transport
AAN	Airworthiness Approval Note
AC	Aircraft Captain
AHASP	Aviation Hazardous Activity Scrutiny Panel
AI	Attitude Indicator
amsl	above mean sea level
ANO	Air Navigation Order
AOC	Air Officer Commanding
AOP	Air Operations Plan
AOR	Area of Responsibility
ARCC	Aeronautical Rescue Coordination Centre
ARO	Aircraft Recovery Officer
ASAV	Air Safety Assurance Visit
ASIMS	Air Safety Information Management System
ASSWG	Air System Safety Working Group
ATC	Air Traffic Control
ATEC	Air Test and Evaluation Centre
ATO	Approved Training Organisation
ATS	Atlantic Training Support
AWC	Air Warfare Centre
AWCASO	Air Warfare Centre Air Staff Orders
BFC	Bustard Flying Club
BSS	Base Support Squadron
CAA	UK Civil Aviation Authority
CAE	Chief Air Engineer
CAP	Civil Aviation Publication
CAS	Chief of the Air Staff
CCP	Critical Care Paramedic
CFI	Chief Flying Instructor
CHT	Cylinder Head temperature
CIM	Critical Incident Manager of the Wiltshire Police
CO	Commanding Officer
COCR	Civil Owned Civil Registered
CoP	Code of Practice
CoV	Certificate of Validity
CPR	Cardiopulmonary Resuscitation
CPT	Command Pilot Training
CRM	Crew Resource Management
Cse	Course
CTP	Chief Test Pilot
D&D	Distress & Diversion at RAF(Unit) Swanwick
DAIB	Defence Accident Investigation Branch
DAR	Designated Airworthiness Representative
DCDSDO	Deputy Chief of Defence Staff Duty Officer
DCDS(MilCap)	Deputy Chief of Defence Staff for Military Capability
DDH	Delivery Duty Holder
DFC	District Fire Commander
DGA	Direction générale de l'armement
DH	Duty Holder
D MAA	Director Military Aviation Authority

**OFFICIAL SENSITIVE**

DTA	Designated Technical Authority
DWFS	Dorset and Wiltshire Fire Service
EASA	European Aviation Safety Agency
EOC	Emergency Operations Centre
EPNER	L'école du personnel navigant d'essais et de reception
ETPS	Empire Test Pilot School
FAA	Federal Aviation Authority
FI	Flying Instructor
FL	Forced Landing
Flt Cdr	Flight Commander
Flt Lt	Flight Lieutenant
Fly Pro	Flying Programme
FOB	Flying Order Book
FOM	MOD Boscombe Down Flight Operations Manager
fpm	feet per minute
FSOL	Fire Shut Off Lever
FSOV	Fuel Shut Off Valve
FSP	Front Seat Pilot
FSV	Formal Staff Visit
FTE	Flight Test Engineer
FTS	Flight Test Schedule
FW	Fixed Wing
GH	General Handling
GPS	Global Positioning System
HF	Human Factors
HSWA	Health and Safety at Work Act
IAS	Indicated Air Speed
IF	Instrument Flying
IP	Instructor Pilot
IQA	Internal Quality Review
IR	Instrument Rating
JARTS	Joint Aircraft Recovery & Transportation Squadron
JCC	Joint Communications Centre of the Wiltshire Emergency Services
JSP	Joint Service Publication
kts	knots
LCB	Life Cycle Briefcase
LTPA	Long Term Partnering Agreement
MAA	Military Aviation Authority
Maj	Major
MAP	Manifold Air Pressure
MAR	Military Aircraft Register
MEL	Minimum Equipment List
MIG	Materials Integrity Group
MFR	Military Flight Release
MFV	Major Foam Vehicle
MOD	Ministry of Defence
MPD	Mandatory Permit Directive
MRP	MAA Regulatory Procedures
MRS	RAF Mountain Rescue Service
MRT	Mountain Rescue Team
m/s	metres per second
NAS	Naval Air Squadron
nm	nautical mile
NOK	Next of Kin
ODH	Operating Duty Holder

**OFFICIAL SENSITIVE**

PCM	Post Crash Management
PCMIO	Post Crash Management Incident Officer
PIC	Pilot in Command
PLC	Public Limited Company
PM	Project Management
PO	Purchase Order
POB	Persons on Board
PTF	Permit To Fly
QE	Qualitative Evaluation
QERB	Qualitative Evaluation Review Board
RA	Regulatory Article
RAFCAM	RAF Centre for Aviation Medicine
RIAT	Royal International Air Tattoo
RN	Royal Navy
RoD	Rate of Decent
R/T	Radio Telephony
RtL	Risk to Life
RWTES	Rotary Wing Test and Evaluation Squadron
SAR	Search and Rescue
SDH	Senior Duty Holder
SEP	Single Engine Piston
SFO	MOD Boscombe Down Station Fire Officer
SofS	Secretary of State
SQEP	Suitably Qualified and Experienced Person
STANEVAL	Standards and Evaluation
SWAST	South West Ambulance Service Trust
TAS	Traffic Avoidance System
TDA	Temporary Danger Area
TLB	Top Level Budget
TO	Tasking Order
TOF	Technical Operating Framework
TORs	Terms of Reference
TP	Test Pilot
TPS	Test Pilot School
USAF	United States Air Force
VFR	Visual Flight Rules
VTC	Video Telephone Conference

**OFFICIAL SENSITIVE**

**PART 1.3 – NARRATIVE OF EVENTS**

<b>Contents</b>	<b>Page</b>
<b>SYNOPSIS</b>	
Overview.....	2
Background to Events.....	2
Air Navigation Order.....	2
Ministry of Defence Boscombe Down.....	3
Long Term Partnering Agreement.....	3
Empire Test Pilots School.....	3
<b>PRE-ACCIDENT EVENTS</b>	
Contractual Arrangements.....	3
Yak-52 2016 Qualitative Evaluation Phase Plan.....	3
Yak-52 2016 Qualitative Evaluation Activity Carried Out.....	4
<b>SORTIE PREPARATION ON 8 JUL 16</b>	
<b>TAKE OFF AND INITIAL PART OF SORTIE</b>	
Overview of Crash Scene.....	5
<b>POST ACCIDENT EVENTS</b>	
Discovery of the Crash Site.....	6
Condition of the Front Seat Pilot.....	6
Condition of the Pilot in Command.....	6
<b>POST CRASH MANAGEMENT</b>	
Arrival of the Emergency Services.....	7
Response by Ministry of Defence units.....	7
Establishment of Ministry of Defence Boscombe Down Control Centre.....	7
Informing of Next of Kin.....	7
<b>SALVAGE OPERATIONS</b>	
Recovery of the Aircraft Wreckage.....	8
Release of the Crash Site.....	8

**Note.** All times given in this Report are local. Throughout this Report, all references to QinetiQ include the relevant parts of the wider corporate entity the QinetiQ Group PLC.



SYNOPSIS



Figure 1.3.1. Yak-52<sup>1</sup> G-YAKB. (Photo source: Owner)

1.3.1. **Overview.** On 8 Jul 16, at approximately 1029 hr, the crew of a UK registered Yak-52 aircraft, call-sign G-YAKB, operating from Ministry of Defence (MOD) Boscombe Down aerodrome (BDN) reported that they had suffered an engine malfunction and attempted a Forced Landing. The aircraft was operating in support of the Empire Test Pilot School (ETPS) and had a crew of 2: the Front Seat Pilot (FSP) was a Royal Air Force (RAF) Test Pilot while the civilian Pilot in Command (PIC) occupied the rear cockpit. In the final stages of the attempted forced landing near to the village of Dinton in Wiltshire, approximately 9 miles to the west of BDN, the aircraft crashed. The PIC suffered serious injuries as a result of the accident and the RAF Test Pilot was pronounced dead at the scene.

1.3.2. **Background to Events.** G-YAKB had been contracted into BDN by QinetiQ as a service from a third party supplier for a week in support of the 2016 ETPS graduate course. On 8 Jul 16 all the flying by students on the course had been completed and the RAF Test Pilot, who was an ETPS course tutor, was conducting a Qualitative Evaluation (QE) sortie of the Yak as part of his role-related continuous professional development.

1.3.3. **Air Navigation Order.** As a civil-registered aircraft, the flight was conducted under the Air Navigation Order (ANO) 2009<sup>2</sup> as amended<sup>3</sup>. G-YAKB had a Permit to

Exhibit 2

Exhibit 3  
Exhibit 4

Exhibit 5

<sup>1</sup> The Yak 52 is a single engine two seat (tandem configuration) low wing primary trainer aeroplane of nominally all-metal construction with full aerobatic capability. The Yak 52 was designed by the Russian company, Yakovlev, and built in Romania under license. Manufacture of the type began in 1979 with more than 1000 being built. This aircraft was produced 1992, entering service initially with DOSAAF, before being ferried to the UK in 1995 and being given the registration G-YAKB. A translation of DOSAAF is Volunteer Society of Assistance of Army, Aircraft and Fleet; it is termed the Ukraine Military Sport Aviation organisation in G-YAKB's Airworthiness Approval Note. Exhibit 1.

<sup>2</sup> The ANO is published as Civil Aviation Publication (CAP) 393.

<sup>3</sup> ANO 2009 was replaced by ANO 2016 on 25 Aug 16; the provisions of ANO 2009 plus all amendments that had been added following its initial publication, applied on 8 Jul 16.

## OFFICIAL SENSITIVE

Fly (PTF) supported by a Certificate of Validity (CoV). Article 23 of the ANO precluded PTF aircraft from undertaking aerial work although demonstration flying could be carried out so long as only the minimum flight crew was carried. The Civil Aviation Authority (CAA) considered the QE activity to be demonstration flying, although the latter term is not defined in any of the Authority's publications. The PTF for G-YAKB stated that: "*The minimum flight crew is: One pilot(s).*" No application had been received by the CAA to conduct aerial work in a Yak-52, neither had the Authority received a request to carry persons on demonstration flights in respect of G-YAKB.

Exhibit 6

**1.3.4. MOD Boscombe Down Aerodrome.** BDN is a Government Aerodrome as defined by the ANO. Whilst the Aerodrome Operator is the military Commander Flying, the operation of the site is through a military/civilian arrangement through the Long Term Partnering Agreement (LTPA) between the MOD and QinetiQ. This report uses BDN to refer to the aerodrome and MOD Boscombe Down to the establishment.

Exhibit 7

**1.3.5. LTPA.** The purpose of the LTPA is to set out the long-term arrangements for the operation and management of a number of MOD sites, including MOD Boscombe Down, and the performance of services in order to ensure the continued availability of test, evaluation and training capabilities and services to the armed forces. Within the LTPA, the ETPS operates from BDN.

Exhibit 8

**1.3.6. ETPS.** ETPS is staffed by a mix of military and QinetiQ employees, who provide the capability to deliver a graduate course to Test Pilot Students (TPS) and Flight Test Engineer Students (FTES). One aim of the ETPS graduate course is to teach the philosophy and skills required to undertake experimental test flying, including QE.

Exhibit 9

### PRE-ACCIDENT EVENTS

**1.3.7. Contractual Arrangements.** For the 2016 ETPS Fixed Wing (FW)<sup>4</sup> graduate course QinetiQ contracted the service through a Framework Agreement held with a third party, Command Pilot Training (CPT) Ltd, enacted through a Purchase Order. CPT Ltd further sub-contracted the service to the PIC, who sourced G-YAKB from its private owner. The service required by the Framework Agreement were flights in a Yak-52<sup>5</sup> from BDN and a Civil Aviation Authority (CAA)/ European Aviation Safety Agency-qualified Flying Instructor (Unrestricted) or a Class Rating Instructor to fly as aircraft captain, and to provide safety, aircraft technical and aircraft procedures briefings on arrival at ETPS.

Exhibit 9  
Exhibit 10  
Exhibit 11  
Exhibit 12

**1.3.8. Yak-52 2016 QE Phase Plan.** The ETPS flying schedule planned for the QE activity began on 4 Jul 16 with the phase exercise tutor taking part in the initial flight. The purpose of the initial flight was for the phase exercise tutor to familiarise the PIC with the exercise techniques that the students were expected to use and local flying procedures. Thereafter one sortie was planned for each TPS and FTES. Included in the schedule was a final sortie on the 8 Jul 16 for an ETPS tutor to conduct a QE sortie in the Yak as part of their own role-related continuous professional development<sup>6</sup>.

Witness 1

<sup>4</sup> The ETPS Graduate Course trains both FW and rotary wing TPS and FTES.

<sup>5</sup> One hr/staff pilot, one hr/student test pilot, and 0.75 hr/student Flight Test Engineer (Exhibit 9). Note the FTES' sorties are flown from the rear cockpit.

<sup>6</sup> All ETPS tutors are required to complete at least one QE flight per year. (Exhibit 13)



## OFFICIAL SENSITIVE

1.3.9. **Yak-52 2016 QE Activity Carried Out.** The week before the arrival of G-YAKB the students were given an exercise phase brief. On 4 Jul 16 the PIC gave a classroom-based technical brief on the Yak-52 to the students in the presence of the phase exercise tutor, followed by a detailed talk about handling the aircraft. The classroom period was followed by each student in turn standing on the wing of G-YAKB and being given a cockpit brief by the PIC. The initial flight with the phase exercise tutor, followed by the first TPS sortie were completed on the first day. QE sorties were completed by all the available TPS and FTES student by cease flying on 7 Jul 16. During their sorties the students noted various unserviceabilities with G-YAKB, although none were reported.

Witnesses 2-6

### SORTIE PREPARATION ON 8 JUL 16

1.3.10. On 8 Jul 16 around 0845 hr the FW Flight Commander (Flt Cdr) spoke briefly to the FSP. That conversation was limited to a confirmation by the FSP that he was happy to take the Yak QE sortie. The ETPS Supervisor saw the FSP and the PIC talking in the ETPS planning room ahead of Meteorological (Met) Brief at 0900 hr. The accident crew out briefed in the ETPS Operations Room at approximately 0930 hr. The crew made their way to the hangar where G-YAKB had been kept overnight and assisted in pushing the aircraft out onto the flight line. Once on the flight line G-YAKB was refuelled with 53 litres of AVGAS 100 but not replenished with engine oil.

Witness 7  
Witness 8

Witness 9  
Exhibit 14

1.3.11. The weather at BDN at take-off was Colour Code Green<sup>7</sup>. Cloud layers were reported at 1200-3000 ft above the Salisbury Plain Training Area with visibility 'GOOD' to 'EXCELLENT'. The surface wind was reported as 240° at 14 knots. To the west of BDN, where G-YAKB was operating, the cloud structure was complex with large broken blocks of cumuliform amongst which there were holes.

Exhibit 15

Witness 10

### TAKE OFF AND INITIAL PART OF SORTIE

1.3.12. The crew had planned a one hour sortie and following engine start, requested taxi at 1006 hr and departed from Runway 23 at 1016 hr under Visual Flight Rules (VFR) to operate to the west of BDN under a Traffic Service<sup>8</sup>. The aircraft climbed to approximately 5200 ft above mean sea level and conducted general handling between 3400 ft and 5200 ft. All transmissions from G-YAKB throughout the accident sortie were made by the FSP.

Exhibit 17  
Exhibit 18

Exhibit 19  
Exhibit 20

1.3.13. Figure 1.3.2 provides an overview of the latter stages of the flight. The crew had flown to the west of BDN where they had conducted aerobatic manoeuvres before the engine stopped, leaving the propeller wind-milling and with no residual thrust.

Witness 11

<sup>7</sup> Green = Cloud base 700ft or higher, Visibility 3.7km or higher. Exhibit 16.

<sup>8</sup> Traffic Service – A surveillance based Air Traffic Service through which a controller provides specific surveillance derived traffic information in addition to the Basic Service available (weather information, conditions at aerodromes, etc.) to assist the pilot in avoiding other traffic. Exhibit 16.

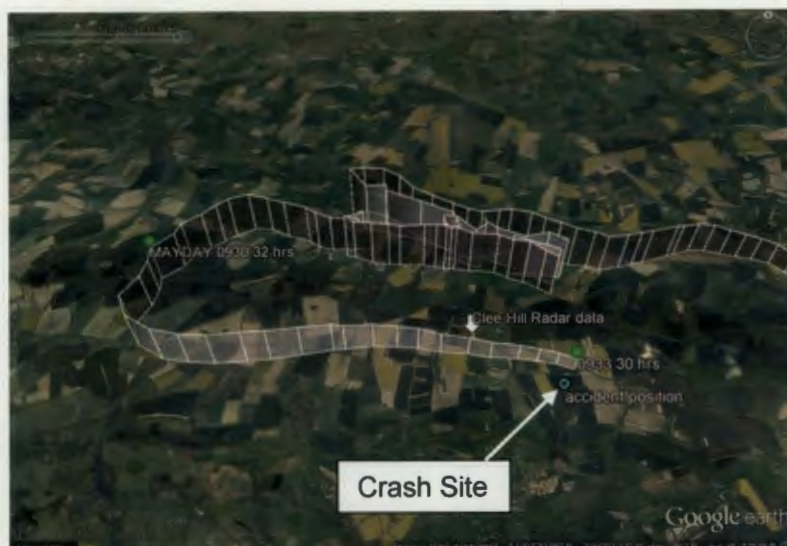

Exhibit 19

**Figure 1.3.2. Radar Trace of Latter Stages of Flight Path taken by G-YAKB.**  
(Picture Source: AAIB)

1.3.14. At 1030 hr the FSP transmitted a Mayday call on the BDN Air Traffic Control (ATC) Approach VHF frequency. The Mayday indicated that G-YAKB had suffered a major but undefined malfunction.

Exhibit 21

1.3.15. ATC provided the crew with a radar vector to return to BDN. The ATC Tower then declared an 'Emergency State 2' to alert the BDN on-site emergency services and bring responders to readiness.

Exhibit 22

1.3.16. At 1031 hr ATC informed Distress and Diversion (D&D) at RAF (Unit) Swanwick that G-YAKB had suffered an aircraft malfunction, called a Mayday and was recovering to the airfield. D&D passed the incident details to the Aeronautical Rescue Coordination Centre (ARCC) at the National Maritime Operations Centre, who in turn alerted the civil police.

Exhibit 23

1.3.17. The aircraft was observed by civilian witnesses passing overhead Chilmark village<sup>9</sup> heading in an easterly direction. Witnesses in the area thought that the aircraft was in distress due to abnormal engine noises.

Witnesses  
12-15

1.3.18. At 1032 hr the FSP transmitted that they were visual with the ground and were probably going to be conducting a Forced Landing into a field west of BDN. ATC gave the crew the surface wind direction and speed at Boscombe Down: 230° at 14 kts.

Exhibit 21

1.3.19. At 1033 hr the FSP told ATC that the crew were making a forced landing into a field just to the west of BDN and that they would phone when they were on the ground. There were no further communications with the crew of G-YAKB.

1.3.20. **Overview of Crash Scene.** G-YAKB crashed in a farmer's field to the north east of Dinton village in Wiltshire at position Lat/Long 51°06'N 001°58'W. The crash site was remote from any public roads. The wreckage was immediately adjacent to

Exhibit 23

<sup>9</sup> Chilmark village is located approximately 4 miles to west of the Dinton crash site.



the south western edge of a landing strip orientated east/west, approximately 800m to the south west of the last radar contact. Four distinct witness marks indicated the initial impact point of the aircraft and subsequent movement. The aircraft had impacted the ground left wing first travelling downwind in an easterly direction, rotated onto its nose and subsequently came to rest facing in a northerly direction amidst, and partially concealed by, standing crops. The surrounding crops at the fourth impact point were mostly undamaged and indicated a near vertical arrival at the final resting point. During the accident sequence the FSP was thrown from the aircraft. The crash was contained within approximately 33 metres. The aircraft fuselage, wings and tail-plane were intact; the engine, although co-located with the remainder of the wreckage, was almost completely detached.

Exhibit 24

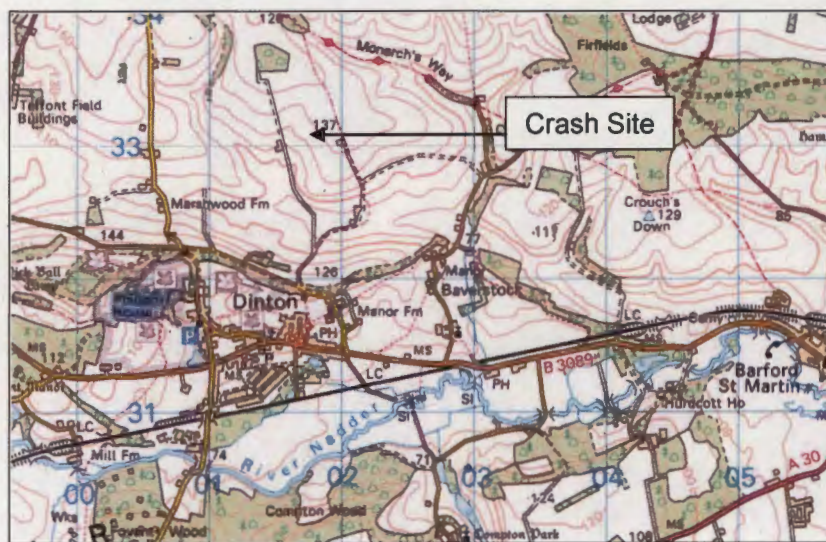

Figure 1.3.3. Map Orientated Grid North to the Top, Showing Crash Location<sup>10</sup>.

### POST ACCIDENT EVENTS

1.3.21. First on the scene was the crew of a BDN based Gazelle helicopter, which had been vectored to the last known position of G-YAKB by BDN ATC. Once on the bearing to G-YAKB's final radar position, the Gazelle crew quickly located the wreckage of G-YAKB. The crew reported to ATC that the Yak-52 had clearly crashed and that there was no sign of any survivors.

Witness 10

1.3.22. Once on the ground the Gazelle Aircraft Captain (AC) found the FSP lying in the farmer's field, an estimated 10m in front and to the north of the crashed aircraft. The Gazelle AC checked the condition of the casualty, noting that the FSP had sustained significant injuries and showed no signs of life.

1.3.23. The Gazelle AC found the PIC sitting strapped into his seat in the rear cockpit but with his parachute harness undone. The PIC was conscious but appeared to be confused. The PIC had sustained significant injuries and was trapped in his seat.

1.3.24. Although the aircraft was partly broken up and the Gazelle AC noted oil on the wreckage, there was no smell of fuel. The rear canopy of G-YAKB was partially

<sup>10</sup> Extract from Ordnance Survey Landranger map 184, 1:50 000 scale, centred on Grid Reference SU0232.



open but distortion of the fuselage had jammed it in position; there was no emergency jettison mechanism. The Gazelle AC was joined at the scene by the military co-pilot of a BDN based Agusta 109, which had also been directed to the scene by ATC. With no tools available, the 2 military pilots attended to the PIC whilst the Gazelle co-pilot took off and hovered to attract and guide the arriving emergency services to the scene.

Witness 16



Figure 1.3.4. Crash Site from approximately 600 ft, Looking in Southerly Direction.

### POST CRASH MANAGEMENT

1.3.25. The emergency services started arriving on the scene from 1110 hr. Although efforts were made to revive the FSP, he was pronounced dead at the scene by a Wiltshire Air Ambulance Critical Care Paramedic (CCP). Firemen used mechanical cutting equipment to remove the rear cockpit canopy under the supervision of a doctor from the Dorset & Somerset Air Ambulance whilst he provided attention to the PIC. The PIC was extricated from the wreckage and then given further treatment once a full head to toe assessment had been completed. The PIC was then transferred by the Dorset & Somerset Air Ambulance to [REDACTED] Hospital Major Trauma Unit.

Exhibit 25  
Witness 17

Witness 18

Witness 19

1.3.26. Since G-YAKB was a civilian-registered aircraft but there was a military pilot on board, both the civilian Air Accidents Investigation Branch (AAIB) from the Department of Transport and the Defence Accident Investigation Branch (Defence AIB) deployed to the crash site. From the outset the AAIB had primacy over the Defence AIB.

Exhibit 26

1.3.27. The post-crash management response organisations at BDN and Royal Naval Air Station (RNAS) Yeovilton along with the RAF Mountain Rescue Service (MRS) were stood up in response to the accident. At 1055 hr the BDN Command Centre was manned to manage the incident. Following a discussion between the AAIB and the civil police it was announced that the investigation of the crash was a civil responsibility; consequently, the airfield post-crash management response from RNAS Yeovilton and the RAF MRS were stood down.

Exhibit 27  
Exhibit 28

Exhibit 25  
Exhibit 29

**OFFICIAL SENSITIVE**

1.3.28. At 1326 hr the Officer Commanding Base Support Squadron (BSS) confirmed within the MOD Boscombe Down Command Centre that the civil police had passed primacy for informing the Next of Kin (NOK), to MOD Boscombe Down. The Casualty Notifying Officer (CNO) was instructed to speak to the NOK. Exhibit 27

1.3.29. At 1430 hr the CNO arrived with the MOD Boscombe Down Padre at the FSP's home address. The CNO met with the FSP's immediate NOK and informed them that the FSP had been pronounced dead at the scene of an aircraft accident. The PIC's wife [REDACTED] she was collected by the ETPS phase exercise tutor and driven to [REDACTED] Hospital. Exhibit 30  
Exhibit 27

1.3.30. At 1535 hr undertakers were tasked to the scene. At 1735 hr the undertakers transported the FSP to the mortuary facility at Salisbury General Hospital. Exhibit 31

**SALVAGE OPERATIONS**

1.3.31. On 9 Jul 16 at 0900 hr personnel from the Joint Aircraft Recovery & Transportation Squadron (JARTS) arrived at the crash site to start the recovery of the Yak wreckage. At the scene JARTS worked with the AAIB to dismantle the wreckage for transportation. Exhibit 29

1.3.32. By 1411 hr on 9 Jul 16 the aircraft wreckage had been removed and the scene cleared. The Police then released control of the crash scene. Exhibit 25



**OFFICIAL SENSITIVE**

**PART 1.4 – ANALYSIS AND FINDINGS**

<b>Contents</b>	<b>Page</b>
<b>INTRODUCTION</b>	
Sortie.....	4
Crash Scene.....	4
Investigating Authorities.....	4
G-YAKB at MOD Boscombe Down.....	4
Qualitative Evaluation.....	5
Yak-52 Qualitative Evaluation Week.....	5
<b>METHODOLOGY</b>	
Accident Factors.....	5
Available Evidence.....	5
Services.....	6
Factors Considered by the Panel.....	7
<b>BACKGROUND</b>	
MOD and QinetiQ Contractual Relationship.....	8
Qualitative Evaluation Model.....	9
Background Summary.....	10
<b>APPLICABLE LEGISLATION</b>	
Air Navigation Order.....	11
Health and Safety at Work Act 1974.....	11
<b>APPLICABLE REGULATIONS</b>	
Joint Service Publication 815.....	11
Military Aviation Authority Regulatory Publications.....	13
Air Warfare Centre Air Staff Orders.....	14
ETPS Flying Order Book.....	15
Duty Holding.....	15
<b>CONTRACTING PROCESS</b>	
Background.....	16
Framework Agreement.....	17
Purchase Order.....	19
Procurement Process.....	19
Assurance of G-YAKB's Documentation.....	20
Insurance.....	21
<b>G-YAKB SUITABILITY FOR QUALITATIVE EVALUATION</b>	
Aerial Work.....	22
G-YAKB Engine Maintenance Regime.....	24
Yak-52 Rear Seat Controls.....	24
Selection of the Yak-52.....	26

**OFFICIAL SENSITIVE**

**G-YAKB SERVICEABILITY**

Maintenance History.....	26
Rear Cockpit Altimeter.....	27
Gyro Compasses.....	27
RPM Gauges.....	28
Rear Cockpit Attitude Indicator.....	29
Front Seat Pilot's Headset.....	29
Multiple Instrument Failures.....	29

**THE CREW OF G-YAKB ON 8 JUL 16**

Front Seat Pilot.....	30
Pilot In Command.....	30
Pilot In Command in the Role of Safety Pilot.....	32
Pilot In Command's Forced Landing Plan.....	32
Selection of the Pilot In Command For Safety Pilot Duties.....	33
Definition of Safety Pilot Duties.....	34
Accident Crew Fatigue.....	35

**ACCIDENT SORTIE PREPARATION**

The Front Seat Pilot's Preparation and Planning for the Sortie.....	35
Qualitative Evaluation Emergency Briefs.....	37
Aviation Task Risk Matrix.....	38
Authorisation.....	40

**ACCIDENT SORTIE**

Accident Sortie Timeline Post-Brief.....	40
Time Management.....	40
Fuel and Oil Replenishment.....	41
Aircraft External Check.....	42
Sortie Profile.....	43
Reliability of the Pilot in Command's Recollection.....	43
Engine Malfunction.....	44
Operation of the Fuel Primer Handle.....	45
Airborne Restarts of the M-14P.....	46
Actions by the FSP.....	48
Intention to Forced Land.....	48
Handling Pilot.....	49
Energy Available at Final Radar Position.....	50
Abandonment.....	51
Forced Landing Actual Impact Point.....	52
Velocity at Impact.....	52
Decision to Attempt to Land on the Landing Strip.....	54
Position of Fire Shut Off Lever.....	54
Position of the Landing Gear Control Lever.....	56
Engine Malfunction Investigation.....	57

**SURVIVAL ASPECTS**

Aircrew Restraining Harnesses.....	57
Aircrew Equipment Assemblies – Helmets.....	59
Aircrew Equipment Assemblies – Rudder Pedal Straps.....	60
Aircrew Equipment Assemblies – Parachutes.....	60

**OFFICIAL SENSITIVE**

Abandonment and Egress Training..... 61

**POST ACCIDENT EVENTS**

Command and Control..... 62  
Damage to Aircraft, Public and Civilian Property and Personnel..... 62  
Emergency Response..... 62  
Safety and Health Aspects of the Response..... 64  
Post-Crash Management..... 64  
Salvage Operations..... 64

**SUPERVISION AND SAFETY CULTURE**

Supervision of Qualitative Evaluation Sorties..... 65  
Supervisory Mechanisms..... 65  
ETPS Student/Staff Interaction..... 67  
Roles of Stakeholders..... 67  
Flight Safety Occurrences..... 68  
Human Factors..... 69

**RISK MANAGEMENT**

Joint Service Publication 815..... 70  
QinetiQ Use of Third-Party Aviation Code Of Practice..... 71  
Yak-52 Historic Occurrences..... 71  
Risk Assessment..... 71  
QinetiQ Risk Assurance Mechanisms..... 73

**COMPARATOR MODELS FOR QE**

Comparison of Qualitative Evaluation at ETPS, L'ecole du personnel navigant d'essais et de reception and the USAF Test Pilot School..... 74

**PREVIOUS REPORTS**

Historic Audits and Assurance Visits at MOD Boscombe Down..... 75

**SUMMARY OF FACTORS**

Causal Factor..... 79  
Contributory Factors..... 79  
Aggravating Factors..... 79  
Other Factors..... 80  
Observations..... 82



INTRODUCTION



Figure 1.4.1 G-YAKB in formation, showing under-carriage fully retracted. (Photograph source: Owner.)

1.4.1. **Sortie.** On 8 July 2016, 18 minutes (min) into a sortie at approximately 1033 hours (hr), civilian Yak-52 aircraft registration G-YAKB crashed following an unsuccessful Forced Landing into a field approximately 9 nautical miles (nm) west of MOD Boscombe Down aerodrome (BDN). The crash resulted in the death of the Front Seat Pilot (FSP), a RAF pilot, and the serious injury of the rear seat pilot, the civilian operator and Pilot in Command (PIC) of the aircraft.

Exhibit 24  
Exhibit 21

1.4.2. **Crash Scene.** The wreckage of G-YAKB was found by a BDN based Gazelle aircraft. The FSP had been thrown clear of the wreckage and was pronounced dead at the scene by an appropriately qualified individual. The PIC was still in the aircraft and seriously injured. The PIC was subsequently extracted from the wreckage by the emergency services and airlifted to [REDACTED] Hospital.

Witness 10  
Witness 17  
Witness 19

1.4.3. **Investigating Authorities.** G-YAKB was a civil-registered aircraft; therefore, the Department for Transport Air Accidents Investigation Branch (AAIB) had primacy for the accident investigation. As the accident involved the death of a Serviceman, the Defence Accident Investigation Branch (Defence AIB) deployed to the crash site. The Director General of the Defence Safety Authority convened this Service Inquiry (SI) on 14 Jul 16 to establish the facts surrounding the death of the Serviceman and provide recommendations to prevent recurrence.

Exhibit 32  
Exhibit 26  
Part 1.2

1.4.4. **G-YAKB at MOD Boscombe Down.** G-YAKB was a privately owned Yak-52 provided for Empire Test Pilots' School (ETPS) student and tutor Qualitative Evaluation (QE) flying, by QinetiQ, through sub-contract with Command Pilot Training (CPT) Ltd<sup>1</sup> who further sub-contracted the service to the PIC. The Yak-52 was a tandem seat propeller driven

Exhibit 33  
Exhibit 9  
Exhibit 11

<sup>1</sup>This report will use CPT Ltd to refer to the Atlantic Group under all of its names.

aircraft and G-YAKB had been sourced by the PIC from its owner. The PIC<sup>2</sup> flew G-YAKB with an ETPS tutor, appointed to run the Yak-52 QE, to BDN on Sun 3 Jul 16. This was the PIC's seventh consecutive year as the Safety Pilot for the ETPS Yak-52 QE, his second with G-YAKB.

Exhibit 12  
Witness 11

1.4.5. **Qualitative Evaluation.** The QE of an aircraft exposes Test Pilots (TPs) to the characteristics of an unfamiliar platform. QE is an important Test Pilot skill. The Yak-52 had a large spinning envelope<sup>3</sup> with readily identifiable characteristics and was unlikely to be familiar to TPs due to its Eastern Bloc heritage, design philosophy and cockpit system; due to these 3 factors it had been selected by ETPS for QE.

Exhibit 34  
Witness 20

1.4.6. **Yak-52 QE Week.** On 4 Jul 16 the PIC flew a familiarisation, or Safety Pilot awareness, sortie with the same ETPS tutor who had accompanied him on the transit sortie. The PIC then completed QE sorties with 5 TP Students (TPS) and 4 Flight Test Engineer (FTE) students during the week 4-7 Jul 16. On 8 Jul 16 ETPS scheduled the PIC to fly 2 QE sorties: a student QE followed by an ETPS tutor QE<sup>4</sup>. This plan changed on 7 Jul 16 due to student illness; the tutor QE became the first flight of the day.

Exhibit 17

Exhibit 35  
Exhibit 36

### METHODOLOGY

1.4.7. **Accident Factors.** The Panel's findings were classified as factors. Once an accident factor had been determined it was assigned to one of the following categories:

Exhibit 37

- a. **Causal Factor.** A factor which, in isolation or in combination with other factors and circumstances at the time, led directly to the accident.
- b. **Contributory Factor.** A factor which made the accident more likely.
- c. **Aggravating Factor.** A factor which made the outcome worse.
- d. **Other Factor.** A factor which was none of the above but was noteworthy in that it may cause or contribute to future accidents.
- e. **Observation.** An issue that was not relevant to the accident but worthy of consideration to promote better working practices.

1.4.8. **Available Evidence.** The Panel had access to the following evidence:

- a. Formal interviews conducted at Air Command, Cody Technology Park Farnborough, Coventry Airport, Ipstones (Stoke-On-Trent) and MOD Boscombe Down.
- b. Health and Safety at Work Act 1974<sup>5</sup>.
- c. Air Navigation Order (ANO) 2009 as amended<sup>6</sup>.
- d. JSP 815<sup>7</sup>.

<sup>2</sup> The PIC occupied the rear seat for the positioning flight to MOD Boscombe Down, for all subsequent sorties with TPS, and on 8 Jul 16.

<sup>3</sup> An aircraft's envelope refers to the capabilities of a design in terms of airspeed, load factor and altitude.

<sup>4</sup> ETPS tutors have to be current for QE and the QE contracts placed with aircraft suppliers allow for flight time for tutors.

<sup>5</sup> Available at <http://www.hse.gov.uk/legislation/> accessed on 27 Feb 17.

<sup>6</sup> Available at [http://www.legislation.gov.uk/ukxi/2009/3015/pdfs/ukxi\\_20093015\\_en.pdf](http://www.legislation.gov.uk/ukxi/2009/3015/pdfs/ukxi_20093015_en.pdf) accessed on 27 Feb 17.

<sup>7</sup> Since superseded.



**OFFICIAL SENSITIVE**

- e. Military Aviation Authority (MAA) Regulatory Publications and Manuals.
- f. Air Warfare Centre Air Staff Orders (AWCASOs), ETPS Flying Order Book (FOB) and other orders from ETPS.
- g. Terms of Reference (TORs) and letters of appointment and delegation.
- h. Sortie planning and briefing materials.
- i. Documentation including flying logbooks, aircraft documentation and engineering documentation.
- j. Technical evidence provided by the AAIB including the Aerostar Yak-52 Manual.
- k. Access to G-YAKB aircraft wreckage through AAIB.
- l. Primary and Secondary radar data of the sortie.
- m. Photography from various sources.
- n. The FSP's QinetiQ Ltd supplied laptop and record of IT-related activity.
- o. Formal statements from witnesses.
- p. Technical reports by 1710 Naval Air Squadron (NAS) Materials Integrity Group (MIG).
- q. Human Factors (HF) provided by RAF Centre for Aviation Medicine (RAFCAM).
- r. An assessment of the Post Mortem report provided by RAFCAM.
- s. Flight Safety related material, including previous Accident reports (extracted from the MOD's Air Safety Information Management System (ASIMS)).

1.4.9. **Services.** The Panel was assisted by the following personnel and agencies:

- a. The aircraft owner.
- b. QinetiQ.
- c. ETPS.
- d. CPT Ltd.
- e. MOD Boscombe Down.
- f. Through AAIB:
  - (1) A Yak-52 operating Subject Matter Expert (SME) at Yak UK Ltd.
  - (2) A Yak-52 engineering SME, who had previously been employed at Russian Aircraft Engineering.
  - (3) Civil Aviation Authority (CAA) Enforcement.
- g. Defence AIB (Air).



- h. 1710 Naval Air Squadron (NAS).
- i. RAFCAM.
- j. Joint Aircraft Recovery and Transportation Squadron (JARTS).
- k. L'école du personnel navigant d'essais et de reception (EPNER).
- l. United States Air Force Test Pilot School. (USAF TPS).
- m. Haywards Insurance Ltd.
- n. Aircraft engineering companies:
  - (1) Air Stratus Ltd.
  - (2) The Classic Aeroplane Co. Ltd.
  - (3) Vintage Engine Technology Ltd.
- o. Representatives of various emergency services.
- p. The British Aerobatics Association.
- q. A Yak-52 operating SME at Sky Trace UK Ltd.
- r. An owner of a Yak-52 and a part-owner of Yak-52.

**1.4.10. Factors Considered by the Panel.** With respect to the accident, the Panel analysed the following key areas:

- a. The applicable legislation and regulation relevant to the accident flight.
- b. Governance and roles in relation to QE and the contracts in place between the parties involved.
- c. The suitability of the Yak-52 and specifically G-YAKB to QE events.
- d. The airworthiness of the aircraft when it arrived at MOD Boscombe Down.
- e. The serviceability of the aircraft for its intended activity.
- f. The competence and selection of the PIC.
- g. AAIB findings relating to possible triggers of an engine malfunction or perceived engine malfunction.
- h. The relevance of individual acts in diagnosing an engine malfunction.
- i. The relevance of individual acts leading to and during the Forced Landing.
- j. The environmental conditions at the time and site of the accident.
- k. The relevance of individual acts following the accident.

- l. Risk Management and Risk Assurance.
- m. Actions that would constitute a reasonable discharge of a Duty of Care.

## BACKGROUND

### MOD and QinetiQ Contractual Relationship

1.4.11. QinetiQ's involvement with ETPS began in 2001. On 1 Jul 01 QinetiQ was formed as a legal entity in its own right, a process which involved the transfer of certain operations and assets of the Defence Evaluation and Research Agency to the Company. The transfer process included contractual arrangements for QinetiQ to take responsibility for the provision of Test and Evaluation and Training Services from sites and facilities that continued to be owned by MOD, such as Boscombe Down. The Long Term Partnering Agreement (LTPA) is the current contractual arrangement covering QinetiQ's provision of these services, including ETPS, and was signed at Secretary of State (SofS) level effective from 1 Apr 03. ETPS is the name given to the school that delivers Test Pilot training out of Boscombe Down but is not a legal entity in itself. Delivery of the ETPS service involves QinetiQ and MOD Air Warfare Centre (AWC) personnel working together, with each party having its own well defined and separate obligations under the LTPA.

1.4.12. **Long Term Partnering Agreement.** The LTPA contract sets out the long term arrangements for the operation and management of sites, and the performance of services, in order to ensure the continued availability of test, evaluation and training capabilities and services to the MOD. This is a customer-supplier contract with MOD named as 'The Authority' and QinetiQ as 'The Contractor'. The contract contains explicitly non-legally binding 'partnering principles' in Clause 2 and a 'no partnership' clause in Clause 81. Revision 05.01 of the LTPA contract, dated 26 Apr 16, was made available to the Panel.

1.4.13. **Long Term Partnering Agreement Key Schedules and Clauses.** The following were germane to this SI:

- a. Schedule 2 Part 2 contained definitions such as, '*Contractor's Airfleet*', '*Authority Allotted Aircraft*' and '*Visiting Aircraft*'.
- b. Clause 20 allowed QinetiQ to subcontract work that related to Non-Tasking Services<sup>8</sup> without MOD's prior written consent.
- c. Clause 20.8 stated "*Notwithstanding Clauses 20.1 and 20.6, the Contractor shall be responsible for all acts and omissions of any Subcontractor or agent of the Contractor.*"
- d. Clause 22 acknowledged that MOD personnel formed a critical element of the partnering arrangement and that they filled regulatory and operational posts within QinetiQ's structure in order to enable the Company to provide capabilities. Amongst others, the following roles were detailed in the agreement as being carried out by MOD personnel: supervision of aircraft operations; supervision of the aerodrome at Boscombe Down; provision of Air Traffic Control (ATC) at Boscombe Down:

- (1) Schedule 22 of the LTPA stated that ETPS operates from MOD Boscombe Down and provided the capability to deliver a graduate course to train a number

<sup>8</sup>*In broad terms Non-Tasking Services (NTS) costs in the LTPA were those that related to the centrally funded costs of maintaining the overall T&E (Test and Evaluation) enterprise in being, while the marginal costs of using any particular LTPA capability for a trial or other activity were borne by the user (DE&S PT or Operating Command) as Tasking Services (TS) costs." Exhibit 38.*



of students drawn from the MOD, QinetiQ and foreign governments. The Schedule included details of the courses and how revenue from the training of foreign nationals was apportioned.

(2) Clause 22 described appointments within ETPS being filled by Service personnel, including the posts of the Commanding Officer (CO) and certain ETPS instructor posts, some of which may be filled by exchange officers from other nations (although this option is not explicitly mentioned in the LTPA).

(3) Clause 22.10(A) stated that it was a MOD obligation to provide AWC Personnel with the appropriate skills, knowledge, qualifications and (where appropriate) currency for the roles to which they are assigned. Whether the Clause extended to flying currencies was not expanded upon.

### Qualitative Evaluation Model

1.4.14. QE is considered a valuable training evolution by western military TP schools<sup>9</sup>. QE trains TPs to identify the specific characteristics of individual aircraft. QE is by necessity conducted on unfamiliar aircraft. UK Military TPs have to remain current in the QE of aircraft. The evolution of aircraft and regional design philosophies are not reflected in the small ETPS fleet; therefore, QinetiQ contracted aircraft owned by third parties with different characteristics and heritages for QE training. Third party aircraft can have any national registration and be either military or civilian.

Exhibit 39  
Exhibit 40  
Exhibit 41

Exhibit 34

1.4.15. The following is a summary of how the QE activity undertaken on 8 Jul 16 and those flights preceding it were viewed within the AWC supervisory construct:

- a. G-YAKB was a Civil Owned Civil Registered (COCR) aircraft that was civil operated. The operator<sup>10</sup> was Command Pilot Training (CPT) Ltd. The PIC was conducting the duties of Aircraft Commander<sup>11</sup> as identified in the ANO 2009.
- b. The activity came under the governance of the CAA.
- c. AWC was not the Activity Owner. ETPS owned the requirement for Yak QE and delivery of the activity was owned by CPT Ltd.
- d. The aircraft was procured for Defence<sup>12</sup> by QinetiQ through a sub-contract with CPT Ltd.
- e. AWC personnel were donated<sup>13</sup> to the operator for the activity.
- f. The airworthiness of the aircraft was legally the responsibility of the owner and aircraft commander, as required by the ANO, and was ensured by the PIC possessing the relevant CAA documentation.

Witness 21  
Exhibit 42  
Exhibit 5

Witness 21  
Witness 22

Exhibit 10

Witness 21

Witness 20  
Exhibit 5  
Exhibit 43

<sup>9</sup> ETPS, EPNER, USAF TPS, and United States Naval Test Pilot School.

<sup>10</sup> The MRP Glossary MAA02: The MRP does not define an 'Operator' but the term is used in various contexts in relation to an entity responsible for all aspects of an aircraft's operation as well as an individual piloting one. The CAA website states that the 'Aircraft Operator' is the holder of the Air Operator Certificate (AOC), which must be approved through the CAA and is specific to the aircraft type and nature of the operation.

<sup>11</sup> The military refers to Aircraft Captain whereas the ANO refers to Aircraft Commander.

<sup>12</sup> Use of the capitalised word 'Defence' in this report, is a reference to the entirety of the UK Government Department titled the Ministry of Defence and the Country's Armed Forces.

<sup>13</sup> Donated is used as a verb to reflect Air Warfare Centre Air Staff Orders wherein Air Duty Holders are described as donor Duty Holders in certain circumstances.

- g. The serviceability of the aircraft was the responsibility of the PIC. Witness 20
- h. The PIC's suitability to perform as Aircraft Commander and Safety Pilot was demonstrated by possession of civilian qualifications. An ETPS tutor flew a familiarisation sortie with the PIC but the purpose of this sortie was not to check his competence. Witness 20
- i. The civilian operation was not authorised by ETPS. Witness 8
- j. There was no Duty Holder (DH) or Aircraft Operating Authority (AOA) for the platform. Witness 21  
Witness 23
- k. A Duty of Care was owed to the accident crew. Witness 20  
Witness 21
- 1.4.16. Notwithstanding the above the Panel noted that:
- a. CPT Ltd did not own or operate Yak-52 aircraft or employ Yak-52 Flying Instructors (FI). The CPT Ltd website<sup>14</sup>, CPT Ltd Management Manual and CAA Document 'Approved Training Organisations Doc. 31, v121' did not include Yak-52 in the list of aircraft types which CPT Ltd operates or offers training on. All 3 domains did state that CPT Ltd offer training for Class Ratings on Single Engine Piston (SEP) aircraft. Exhibit 44  
Exhibit 45
- b. The aircraft and PIC were supplied by a sub-sub-contractor, the PIC himself, who CPT Ltd correctly considered to be the aircraft operator<sup>15</sup>. The PIC had sourced the aircraft from its owner who had given the PIC permission to use the aircraft via e-mail. Exhibit 11  
Witness 24  
Exhibit 12
- c. As a Permit To Fly aircraft, the airworthiness of G-YAKB was the legal responsibility of the owner; in accordance with UK CAA Civil Aviation Publication (CAP) 733 'Permit to Fly Aircraft'. In accordance with the Air Navigation Order (ANO) 2009<sup>16</sup>, as Aircraft Commander when the PIC took charge of the aircraft he became responsible for the continuing airworthiness. Exhibit 43
- d. Whilst the military chain of command at MOD Boscombe Down did not directly supervise the Yak-52 operator, it did supervise the ETPS QE participants. ETPS orders and procedures did provide mechanisms to review and scrutinise the activity. ETPS supervisors were in a position to affect the activity. Exhibit 46  
Exhibit 47

### Background Summary

1.4.17. On 8 Jul 16 it was a QinetiQ responsibility to provide the QE service to Defence. Military personnel were in place to supervise ETPS military flying operations but not those conducted by civil operators, such as those through the contract with CPT Ltd.

<sup>14</sup><http://www.commandpilottraining.com/training-fleet> accessed on 28 Feb 17.

<sup>15</sup><http://eur-lex.europa.eu/legal-content/EN/TXT/?uri=CELEX:02008R0216-20130129> accessed on 21 Apr 17.

<sup>16</sup>[http://www.legislation.gov.uk/ukksi/2009/3015/pdfs/ukxi\\_20093015\\_en.pdf](http://www.legislation.gov.uk/ukksi/2009/3015/pdfs/ukxi_20093015_en.pdf) accessed on 1 Mar 17.

**OFFICIAL SENSITIVE**

**ANALYSIS OF FACTORS**

**APPLICABLE LEGISLATION**

**Air Navigation Order**

1.4.18. The flight was conducted under the ANO 2009<sup>17</sup> as amended. The ANO was a statutory instrument made under powers conferred by the Civil Aviation Act 1982 that formed the legal basis for almost all areas of UK domestic civil aviation that were regulated at a national level.

**Health and Safety at Work Act 1974**

1.4.19. The Health and Safety at Work Act<sup>18</sup> (HSWA) stated that the employer's general duties included<sup>19</sup> the duty to ensure, so far as is reasonably practicable, the health, safety and welfare at work of all his employees. This is further broken down in the source legislation and can be summarised as the provision and maintenance of safe equipment, a safe place of work and a safe environment; the legislation also requires provision of information, training and supervision. Safe is explained to be, so far as is reasonably practicable, without risks to well-being, health and life. In addition to these statutory duties, the employer owed a common law<sup>20</sup> Duty of Care to employees. The Health and Safety Executive (HSE) and the Civil Aviation Authority (CAA) had a Memorandum of Understanding (MoU) which clarified their responsibilities with respect to regulation of the operation of aircraft. Further guidance was issued in CAP 1484. Under the MoU the CAA was responsible for regulating the activities of crew members whilst on board aircraft. The CAA was also responsible for the safety of air navigation and aircraft, including airworthiness, the certification of operators and the licensing of aircrew.

1.4.20. The HSWA was relevant as it contained the employer's duties and was the source of definitions contained in Joint Services Publications (JSPs). This is expanded upon below. In practice, many aspects of the discharge of the employer's duties should have been met before G-YAKB took off.

**APPLICABLE REGULATIONS**

**JSP 815**

1.4.21. JSP 815<sup>21,22</sup> contained policy and direction for Health Safety and Environmental Protection within Defence. It included the SofS policy statement that required health and safety risks to be reduced to Tolerable and ALARP. JSP 815 stated that health and safety risks included Risk to Life (RtL).

1.4.22. JSP 815 stated that the SofS policy statement "*applies to everyone and all organisations within Defence, including contractors and partner organisations, who conduct defence activities.*" The contents of JSPs are however, applicable to contractors only when formalised through a contract. JSP 815 did not apply to QinetiQ as, despite being MOD

---

17 The ANO is published as Civil Aviation Publication (CAP) 393.

18 <http://www.hse.gov.uk/legislation/hswa.htm> accessed on 1 Mar 17.

19 There are other duties to others affected by the employer's actions eg. general public.

20 *Wilsons v Clyde Coal Co v English* (1938).

21 In Aug 16 JSP 815 was replaced by DSA01.1; on 8 Jul 16 JSP 815 Pt 1 (V3.0 Dec 14) was applicable.

22 [https://www.gov.uk/government/uploads/system/uploads/attachment\\_data/file/549121/JSP-815-Dec-14-Legacy-With-Archive-Text.pdf](https://www.gov.uk/government/uploads/system/uploads/attachment_data/file/549121/JSP-815-Dec-14-Legacy-With-Archive-Text.pdf) accessed on 1 Mar 17.



policy and the publication applying to defence contractors, compliance was not formalised through the LTPA contract.

1.4.23. The Panel considered it reasonable for people in positions of responsibility within Defence to have been aware of the contents of JSP 815. The Panel also considered the maintenance of military test pilot skills and of a mandated currency, to be a Defence activity. The QE sortie had to be considered Defence activity as it only occurred due to a Defence requirement. This was delivered through the sub-sub-contracted activity of G-YAKB on 8 Jul 16.

Exhibit 48

1.4.24. JSP 815 reiterated that employers had duties to their employees and these were devolved upon managers and COs. The duties were those laid down in the HSWA and "may be referred to as a 'Duty Of Care'". The general duties of employees at work, as laid down in the HSWA, were not expanded upon in JSP 815. Duty of Care was owed by the MOD to the FSP in that he was being placed within the operations of a third party while on duty. A separate Duty of Care was owed by QinetiQ to the accident crew, as the QE sortie was a service delivered to Defence by QinetiQ. The ETPS students and the FSP also had responsibilities<sup>23</sup> in that as qualified personnel they had the knowledge and skills to raise an issue if they felt that they were inadequately briefed or any equipment was not operating correctly. Furthermore, the accident crew owed a Duty of Care to each other and themselves.

1.4.25. The Management of Health and Safety at Work Regulations (MHSWR) 1999 identified that it was a legal requirement to conduct a risk assessment for work-related activities<sup>24</sup>. A Risk Assessment for QE existed in the form of an ETPS QE Flight Test Schedule (FTS), whose purpose was to capture generic QE risks, and a type specific addendum. The Yak-52 Addendum was almost identical to type specific addendums for other aircraft used by ETPS that were significantly different. The FTS contained 4 risks and the Yak-52 Addendum contained 2, with overlap between the 2 documents. This was the only evidence of a safety analysis having been carried out for the Yak-52 type or G-YAKB specifically.

Exhibit 46  
Exhibit 49

1.4.26. The Panel noted that JSP 815 contained direction that activities required safety cases, whereas the MRP mandated them for air systems. This report will use the term 'safety case' to mean a safety argument for an activity. An appropriate Risk Assessment is a vital input to an activity's safety case<sup>25</sup> such that an employer may identify whether a reasonably foreseeable Risk to Life (RtL) exists and to conclude and demonstrate that risks had been reduced to Tolerable and ALARP in the discharge of its Duty of Care. In the case of Yak QE, the RtLs were owned by the operator; however, MOD could still have concluded that they had been reduced to Tolerable and ALARP. This was not demonstrated prior to QE. The failure to produce an appropriate safety case for Yak-52 QE represented a missed opportunity to review whether the totality of risk associated with the activity had been identified and mitigated. Production of a safety case need not be onerous and some of the constituents of one were in existence prior to QE. The ETPS Risk Assessment was considered in paragraph 1.4.244 and subsequent paragraphs. The contents of a safety case are considered in paragraph 1.4.246

Exhibit 151

<sup>23</sup>Under Section 7 of the Health and Safety at Work Act 1974 and Regulation 14 of the Management of Health and Safety at Work Regulations 1999. ([http://www.legislation.gov.uk/ukksi/1999/3242/pdfs/uksi\\_19993242\\_en.pdf](http://www.legislation.gov.uk/ukksi/1999/3242/pdfs/uksi_19993242_en.pdf) accessed on 3 Mar 17).

<sup>24</sup>JSP 815 Part 1 Chapter 5 Paragraph 7 also requires HS&EP management arrangements to address risk assessments and safety cases in manners that are appropriate and proportionate to the organisation and activities being carried out.

<sup>25</sup>JSP 815 Part 1 Chapter 5 Paragraph 9 Footnote: "A safety case is a structured argument, supported by a body of evidence that provides a compelling, comprehensible and valid case that a system is safe for a given application in a given operating environment."

1.4.27. The Panel concluded that the Risk Assessment contained in the FTS and Yak-52 addendum did not constitute an adequate safety case for QE for the reasons given above, which resulted in a reduction in the employer's opportunities to both discharge and document a Duty of Care, was an **Other Factor**.

1.4.28. **Recommendation.** The Chief Test Pilot should ensure that, prior to any further QEs being conducted, all ETPS activities benefit from the production of a safety case, which demonstrates how the employer's general duties are to be delivered and assured, in order to record that he has been satisfied that the risks have been reduced to Tolerable and ALARP.

#### Military Aviation Authority Regulatory Publications

1.4.29. JSP 815 identified that the MAA was the regulator for Military Air Safety. The MAA Regulatory Publications (MRP) stated that they apply to operations of aircraft on the Military Aircraft Register (MAR); however, MAA01: Military Aviation Authority Regulatory Policy, in a footnote on page 14, identified that it specifically excluded "*civil registered aircraft where regulation is provided by civil regulators.*"<sup>26</sup> QE in G-YAKB was a civilian operation of a COCR aircraft; therefore, the activity was not regulated by the MRP. Whilst the MRP per se was inapplicable, there were Regulatory Articles (RA) within the publication that were relevant:

Exhibit 50

a. RA 1240 – Chartering Of Civilian Aircraft For Military Purposes – Air Safety. RA1240 regulated the chartering of civilian registered aircraft to augment military aircraft fleets. The QE activity was specifically contracted as requiring flights from BDN as part of the ETPS course and as such the Panel considered it to be supplementing the fleet available to ETPS. The aircraft was specifically hired, or chartered, for the Military Purpose of TPS and FTE training and TP currency. RA1240 was used by QinetiQ Project Management at MOD Boscombe Down as a guide to hiring third party aircraft. A QinetiQ employee arrived at formal interview with a printed copy of RA1240 and informed the Panel that they had been briefed to use it when hiring third party Aircraft.

Exhibit 51

Witness 25

b. RA 1410 – Occurrence Reporting. RA 1410 referred to Aviation DHs, Accountable Managers, Heads of Establishment, and Commanders within DH-facing organizations. RA 1410 stated that "*accurate and timely occurrence reporting and effective investigation is fundamental to identifying Air Safety risks and delivering effective mitigation*"; furthermore, "*All Air Safety Occurrences and failures of safety controls must be reported and investigated to a suitable depth*". The RA stated that occurrences involving civilian registered aircraft were to be reported via Defence Air Safety Occurrence Report as well as through the CAA reporting system.

Exhibit 52

1.4.30. The MRP introduced a fundamental delineation of governance between civilian registered aircraft and those on the MAR by way of footnote. This was not prominent and could be missed, leading to a misunderstanding of the governance of civilian registered aircraft operations.

1.4.31. The Panel concluded that:

a. The delineation of governance between civilian registered aircraft and those on the MAR was not prominent in the MRP. This was an **Observation**.

b. RAs relevant to the operation of civilian registered aircraft existed within an

<sup>26</sup>[https://www.gov.uk/government/uploads/system/uploads/attachment\\_data/file/578278/MAA01\\_Issue\\_6.pdf](https://www.gov.uk/government/uploads/system/uploads/attachment_data/file/578278/MAA01_Issue_6.pdf) accessed on 3 Mar 17.

otherwise inapplicable MRP in order to act as 'signposts' to the correct legislation or offer guidance in the absence of regulation. This was an **Observation**.

**1.4.32. Recommendations:**

- a. The Director MAA (D MAA) should review the MRP to ensure prominence of the document's applicability to civil registered aircraft.
- b. The D MAA should review the location of RAs pertaining to the operation of civil registered aircraft.

**Air Warfare Centre Air Staff Orders**

1.4.33. Air Warfare Centre Air Staff Orders (AWCASOs) Order A2370(7).6 contained orders for QEs on aircraft operated by non-military organisations. It stated that:

Exhibit 41

*"Approval. QE flying by AWC QE aircrew on aircraft operated by non-military organisations is to be approved by AWC CTP/DDH through the presentation of the proposed QE at the AWC Trials Approvals Group (ATAG) or Aviation Hazardous Activity Scrutiny Panel (AHASP) iaw the AWC Trial Guide. The following areas must be addressed at the ATAG/AHASP.*

- (1) *The flying qualifications of the aircraft commander and crew.*
- (2) *Prior to a student TP QualEval flight, a qualified TP (preferably a TP AI) should conduct a QE with the aircraft commander if they are not a qualified TP.*
- (3) *The certification of the flying organisation.*
- (4) *Aircraft airworthiness."*

The Yak-52 QE activity was not presented at AHASP in the tenure of the incumbent Chief Test Pilot. Assurance of the airworthiness of G-YAKB was not in the AWC's Chief Air Engineer's (CAE) TORs. QinetiQ Airworthiness was not required to assure the airworthiness of third party aircraft. The Chief Test Pilot believed that any issues with the airworthiness of G-YAKB would have been brought to his attention by the CAE or QinetiQ personnel. Whilst the contracted organisation was an ATO, the Yak-52 QE sorties were to be delivered by the PIC. The Chief Test Pilot had approved ETPS personnel's involvement in QE correctly using a blanket 'Form 2'<sup>27</sup>. The AHASP is a QinetiQ Risk Assurance activity and was considered in paragraph 1.4.251.

Witness 21  
Exhibit 53  
Witness 26  
Witness 21

Exhibit 44  
Exhibit 11  
Exhibit 42

1.4.34. As Yak-52 QE was not presented at AHASP, the Risk Assessments associated with it were not subjected to scrutiny outside of ETPS. Contractual documentation was not refreshed and the contractual arrangement whereby the ATO was not actually delivering the Yak-52 QE escaped scrutiny. Presentation at AHASP may have resulted in the absence of planned airworthiness assurance activity by QinetiQ and MOD personnel being noted. In turn this may have resulted in it being identified that the Chief Test Pilot could not be assured of G-YAKB's airworthiness by either QinetiQ or MOD. Whilst AHASP may have scrutinised the PIC's qualifications, AWCASOs did not order scrutiny of his currency. This meant that, even had an AHASP scrutinised Yak-52 QE, it may not have addressed pilot currency which is a critical element of competence. The lack of an AHASP for Yak-52 QE is probably explained by the activity being assumed by stakeholders to have been correctly approved originally, which was not subsequently questioned due to it recurring annually. This assumption may have been strengthened as the aircraft was simple in comparison to some encountered at MOD Boscombe Down.

<sup>27</sup> In accordance with AWCASOs.



1.4.35. Yak-52 QE was not presented at AHASP as required by written orders, which removed a significant opportunity to: scrutinise the risks associated with Yak-52, identify the lack of planned airworthiness assurance, and understand the contractual arrangements being used to provide the service. This was an **Other Factor**.

#### ETPS Flying Order Book

1.4.36. The sortie, as a civilian operation, was not conducted under orders contained in the ETPS FOB; however, ETPS personnel were still bound by orders contained in the FOB, FTS and FTS Addendums. Whilst the MRP did not apply to civil registered aircraft, personnel could be ordered to conform to it. FOB Order E2305(6).3 stated incorrectly that the MRP applies to "both civil and military registered aircraft". FOB Order E2305(6).4 stated: "*Civil Owned, Civil Registered (COCR) Aircraft. When operating COCR aircraft both military and civilian personnel must abide by the regulations in both the MRP and CAP 393, obeying the more limiting regulatory pathway*". ETPS supervisors gave inconsistent answers as to under which legislation and/or regulation QE flights were conducted. Multiple Flight Safety occurrences went unreported during QE week in contravention of RA 1410 to which participants had been ordered to conform. The Flight Safety occurrences are reviewed in paragraph 1.4.239.

Exhibit 46

Witness 8  
Witness 20

1.4.37. ETPS was not the operator of G-YAKB in a regulatory sense, the civilian PIC was the operator. ETPS personnel, both QinetiQ civilians and military, were flying in G-YAKB, controlling the aircraft and running the QE sorties. In this sense as individuals, the personnel were operating the aircraft and its systems; therefore, their activities fell within the direction given by the FOB Order E2305(6).4. QE participants could be expected to have followed the direction in Order E2305(6).4 or to bring it to the attention of a supervisor, if compliance with it proved impossible. This was particularly pertinent as the reporting requirements of the MRP were not followed.

1.4.38. The FOB applied to ETPS QE participants, who were ordered to conform to the MRP. By not conforming to the MRP and in particular the reporting requirements of RA 1410, QE participants were not following the orders contained in the FOB which was an **Other Factor**. A lack of occurrence reporting contrary to written orders indicated a requirement for the Panel to consider the ETPS Safety Culture. Following the accident RAFCAM conducted a Human Factors study which considered, amongst other topics, the Safety Culture at ETPS. This study is summarised in paragraph 1.4.240.

1.4.39. **Recommendations.** The CO ETPS should:

- a. Review the FOB to ensure that it complies with the Air Navigation Order and MAA Regulatory Publications.
- b. Put in place robust measures to ensure that all ETPS personnel understand reporting requirements, when operating both ETPS fleet and third party aircraft, in order to ensure that all relevant occurrences are reported.

#### Duty Holding

1.4.40. The MRP set out the roles and responsibilities of Aviation Duty Holders (ADH). An ADH was personally responsible for management of the RtL for a specific platform or specified systems. The MRP did not apply to this civilian operation and no one had been appointed ADH for the Yak-52.

Exhibit 54

Witness 21

1.4.41. The SofS Policy Statement on Health, Safety and Environmental Protection in Defence at Annex A to JSP 815 required each Top Level Budget (TLB) holder to be the Senior Duty Holder (SDH) for the safety of Defence activities carried out within their Area of



**OFFICIAL SENSITIVE**

Responsibility. The TLB holder for the LTPA, through which ETPS was delivered, was the Deputy Chief of Defence Staff for Military Capability (DCDS(MilCap)). The DCDS(MilCap) Area of Responsibility (AoR) includes Weapons Evaluation and Capability Assurance (WECA), the conduit for funding from the TLB to the LTPA; however, the SDH for Test and Evaluation (T&E), of which Test Support Flying<sup>28</sup> was a subset, was the Chief of the Air Staff (CAS).

Exhibit 55

Exhibit 56

1.4.42. Letters of appointment were issued by CAS to the RAF's Chief of Staff for Operations (COS(Ops)) and the Chief Test Pilot appointing them as the Operating Duty Holder (ODH) and Delivery Duty Holder (DDH) respectively for Test and Evaluation (T&E) activity within their AoR. To define the recipients' AoRs, the letters of appointment use the terms Air System and Air Safety. These terms are defined in the MRP<sup>29</sup> and are only applicable to military systems.

Exhibit 56

Exhibit 57

1.4.43. In the cases of organisations approved by the MOD under the Contractor Flying Approved Organization Scheme, an Accountable Manager (Military Flying) (AM(MF)) was appointed in accordance with the MRP with corporate and financial authority to make independent decisions on Air Safety when a civilian company was operating Air Systems that were registered on the MAR. G-YAKB was not on the MAR; therefore, there was no AM(MF).

1.4.44. There was incoherence between JSP 815, requiring DHs to be appointed to activities and the MRP requiring ADHs to be appointed for platforms. Whilst JSP 815 required there to be an SDH for the activity, it was not clear to whom this role fell.

1.4.45. Whilst letters of appointment were issued for DDH and ODH the Yak QE was not covered by either role. There was no AM(MF), DDH or ODH for QE activity conducted in G-YAKB which was an **Other Factor**.

**1.4.46. Recommendations:**

- a. The CAS should review the Senior Duty Holder role for QE to ensure that this Defence activity falls within the Duty Holder construct.
- b. The Senior Duty Holder should re-issue letters of appointment to the T&E ODH and DDH emphasising their Duty of Care responsibility for Defence activity within their AoRs for which they do not Duty Hold.

**CONTRACTING PROCESS**

**Background**

1.4.47. The use of a Yak-52 for QE with the PIC as Aircraft Commander and Safety Pilot has been occurring annually at MOD Boscombe Down for the last 7 years. Prior to this Yak-52 QE had been delivered through other aircraft operators. The PIC's involvement in QE had always been in the same capacity but was, for the first 2 years, arranged through another Yak-52 owner, who had been contracted to provide the aircraft. The PIC was subsequently approached by ETPS and asked to continue in his role but with the service contracted through Atlantic Training Support (ATS) Ltd, part of the Atlantic Group and an Approved Training Organisation (ATO) who already supplied services to ETPS. This was achieved through an overarching 'Framework Agreement' between QinetiQ and the ATO lasting 5 years under which Purchase Orders (PO) would be placed for individual packages

Witness 11

Exhibit 2

<sup>28</sup> QE is included in Test Support Flying as defined at MAA02 Issue 6.1 p120.

<sup>29</sup> [https://www.gov.uk/government/uploads/system/uploads/attachment\\_data/file/577569/MAA02\\_Issue\\_6.1.pdf](https://www.gov.uk/government/uploads/system/uploads/attachment_data/file/577569/MAA02_Issue_6.1.pdf) accessed on 6 Mar 17.



**OFFICIAL SENSITIVE**

of activity. The PIC had never been an employee of the ATO; instead, his services were further sub-contracted by the ATO. ATS now trades as CPT Ltd with the same company registration number and CAA Approval.

Exhibit 11  
Exhibit 58

1.4.48. MOD interviewees considered the QE activity to be owned by CPT Ltd. CPT was neither the owner nor the operator of G-YAKB and considered the QE activity to be owned by the PIC. Notwithstanding contractual obligations to provide a Yak flown in accordance with CAA regulations, CPT Ltd considered itself to be a contracting mechanism by which QinetiQ could access the operator, the PIC, who had no ability to contract direct with QinetiQ. CPT Ltd was due to receive financial gain from the activity. Personnel at MOD Boscombe Down formed the belief that the service they had contracted for, and were receiving, was assured because it was delivered by an ATO.

Witness 21  
Witness 22  
Witness 24

Witness 20

**Framework Agreement**

1.4.49. The Framework Agreement for the hire of the Yak-52 and PIC was between QinetiQ and ATS Ltd. The Framework Agreement was signed in Jun 13. QinetiQ was identified as 'the Purchaser' and ATS Ltd as 'the Sub-contractor'. ATS Ltd subsequently changed its name to CPT Ltd. The Agreement allowed for further sub-contracting of the service and CPT Ltd was not an operator of Yak-52s; therefore, CPT Ltd raised a further sub-contract with the PIC to supply the service using G-YAKB. The PIC did not own G-YAKB and had entered into an agreement with the owner to use it for QE. In relation to the contracted arrangements:

Exhibit 2

Exhibit 44  
Exhibit 45  
Exhibit 11  
Exhibit 12

a. The services required by the Framework Agreement were flights in a Yak-52 from BDN and a CAA/European Aviation Safety Agency (EASA) qualified Flying Instructor (Unrestricted) or a Class Rating Instructor to fly as aircraft captain, along with safety, aircraft technical and aircraft procedures briefings on arrival at ETPS.

Exhibit 2

b. QinetiQ Procurement was in possession of the following documents pertaining to the companies that made up Atlantic Group. These were released to the Panel immediately:

(1) An Air Operator's Certificate for Atlantic Air Transport Ltd, trading as Air Atlantique.

Exhibit 59

(2) CAA maintenance accreditation in the form of an Approval Certificate, for Atlantic Air Motive Ltd, issued 11 Aug 93 with a revision date of 7 Sep 05.<sup>30</sup>

(3) Lloyd's Quality Assurance Certification for Atlantic Air Motive Ltd, with an expiry date of 31 Aug 07.

Exhibit 59

(4) Air Atlantique employer's insurance documentation, valid 01 Oct 07 until 01 Oct 08.

Exhibit 59

(5) An 'Equifax' Business Information report into the dealings of ATS Ltd dated 25 Sep 08.

Exhibit 59

(6) Companies House name change document showing ATS had changed its name to CPT Ltd on 19 May 14.

Exhibit 58

c. QinetiQ received a letter dated 10 Jun 14 from CPT Ltd stating that the company had changed its name from ATS and that their company number and CAA Approval

Exhibit 58

<sup>30</sup>This document is not referenced as an exhibit because it had no bearing on the accident.



remained in place. This was given to the Panel 6 months after the accident following a search of QinetiQ records. An updated version of the Framework Agreement had not been produced (as this was not required on name change); however, the ETPS Project Management (PM) office did not know whether the ATO's CAA accreditations had transferred with the name change.

Witness 26

d. The Framework Agreement stated: "*The Purchaser is not liable for any of the Sub-contractor's acts or omissions*".

Exhibit 2

e. CPT Ltd was contractually responsible for the supply of a Yak flown in accordance with CAA regulations and "*aircraft captain*" to QinetiQ. The Framework Agreement used the term "*safety pilot*" in the background paragraph and aircraft captain in the deliverables list, however it did not define these duties. The definition of the roles of a safety pilot and assurance of competence are discussed in paragraph 1.4.116.

Witness 27  
Witness 28

f. The Framework Agreement stated that CPT Ltd was responsible for the supply of engine oil. The supply of oil to the QE Yak had been arranged locally with QinetiQ in the past and this arrangement had endured. Sometimes QinetiQ technicians replenished the engine oil of G-YAKB.

1.4.50. The Framework Agreement simplified the contractual aspects of a recurring event. Whilst QinetiQ had accumulated an amount of documents that had time lapsed and there were inconsistencies in the Framework Agreement, QinetiQ were in possession of sufficient documents to conclude that they were contracting with an accredited ATO; however, ahead of the 2016 QE the validity and utility of the information held was not checked. Additionally, CPT Ltd was not itself a Yak operator and had to further sub-contract the activity. In this situation, the service was no longer being delivered by CPT Ltd although they remained contractually responsible for it. The Panel was given no evidence that assurance activity, other than the collection and storage of documents cited, of CPT Ltd's accreditation and capabilities had taken place.

1.4.51. The Panel concluded that:

- a. The documentation required to show that CPT Ltd was an accredited ATO was not held in one location with the result that no single person had the visibility or understanding needed to confirm the ATO's accreditation. This was an **Observation**.
- b. Although the further sub-contracting of the Yak service to the PIC was allowable within the Framework Agreement, the fact that it had been and that the ATO was therefore not directly delivering QE, was not drawn to the attention of ETPS supervisors. This removed the opportunity to scrutinise the further sub-contracted QE activity for additional risk, and was an **Other Factor**.

1.4.52. **Recommendations:**

- a. QinetiQ should put in place robust measures to ensure that the further sub-contracting of third party aviation is understood, appropriately approved and any necessary assurance activity takes place.
- b. The Chief Test Pilot should put in place robust measures to ensure that, prior to the hiring of a third party aircraft by QinetiQ for ETPS use, he understands the contractual arrangements in order to better assess the risk to his personnel.

**Purchase Order**

1.4.53. Once a Framework Agreement had been established, QinetiQ personnel within ETPS raised a 'Call-off Contract' for the supply of services, which was supposed to have comprised a Purchase Order (PO) and Tasking Order (TO) against the associated provider. The PO process was controlled by QinetiQ personnel in the ETPS PM's office with requisitions endorsed by QinetiQ Procurement staff at an appropriate level determined by the monetary value of the contract. In relation to the contract for a Yak-52:

Exhibit 2  
Witness 25

- a. The use of the Yak-52 type and the individual PIC had been occurring for 7 years. It had become routine for ETPS to request the service through CPT Ltd.
- b. Neither the Procurement Office nor the ETPS PM created a TO for the Yak-52 2016 QE activity.
- c. CPT Ltd did not formally accept the PO in writing; however, the document stated that the provision of the service indicated that the contractor was content to accept the task.
- d. On 10 May 16 ETPS placed a PO with CPT Ltd against the Framework Agreement. The PO 'Item Description' was:

Witness 11  
  
  
  
  
  
  
Exhibit 10

*"Yak 52 hire Week commencing 01 July 16 for five days including:*

- Up to 15 flying hours required*
- Positioning Flights*
- Pilot for 5 days*
- Pilot T&S*
- Landing fees"*

The PO included a total price for the service.

1.4.54. The 1 Jul 16 (the start date of the contracted activity) was a Friday and not the planned day of QE commencement, 5 days after that would have been Wed 6 Jul 16. Whether the PO meant 5 consecutive working days or 5 individual days commencing on 1 Jul 16 is unclear.

1.4.55. The Panel found no evidence that a handover process took place between QinetiQ procurement, who set up the Framework Agreement, and ETPS Project Managers who placed the Yak-52 PO. ETPS managers sought approval from QinetiQ Procurement for the commercial aspects of POs. Witnesses from both functional areas were unable to describe a clear and universally understood relationship between the QinetiQ procurement and ETPS project/programme management functions. During interview witnesses stated that the other functional area was responsible for completing the same task. The QinetiQ Code of Practice (CoP) for the 'Use of Third Party Aviation' existed at the time of the accident; however, it was not categorical as to who was tasked with what. The ETPS Project Manager did not know of the existence of the CoP.

Witness 25  
Witness 29  
  
  
Exhibit 60  
Witness 25

**Procurement Process**

1.4.56. QinetiQ used a Procurement Process that considered ETPS in its entirety to be a programme within QinetiQ. Events such as QE were run as projects within this programme. All project specific documentation for these projects was supposed to be stored in a dedicated 'Life-Cycle Briefcase' (LCB), designed to keep all relevant documentation in one place. At the time of the accident a LCB existed for Yak QE; however, it did not contain all relevant documents.

Witness 26  
  
  
Witness 25

1.4.57. QinetiQ personnel made contractual arrangements with CPT Ltd that could not be fulfilled without further sub-contracting. Neither Procurement nor the PM office had single ownership of the QE contracting activity. An appropriate handover process would have provided an opportunity for Procurement to inform the PM office what had been arranged and with whom. In turn this would have allowed PM to better understand what tasks needed to be achieved and clarified their responsibilities when placing POs.

1.4.58 The Panel came to the following conclusions in relation to the procurement and project management activities:

- a. The personnel charged with delivering the procurement and project management were not Suitably Qualified and Experienced Personnel (SQEP)<sup>31</sup> for their roles and did not consult personnel who were, removing an opportunity to review the risk associated with the activity. This was an **Other Factor**.
- b. Despite the existence of a CoP for the Use of Third Party Aircraft and a published Procurement Process, personnel were unable to describe the process and did not demonstrate understanding of their roles and responsibilities. This was an **Other Factor**.

1.4.59. **Recommendations:**

- a. QinetiQ should review the process for the contracting of QE services to clearly define the responsibilities for the assurance of the service to be provided.
- b. QinetiQ should ensure that a single Suitably Qualified and Experienced Person has overall accountability for QE procurement.

#### **Assurance of G-YAKB Documentation**

1.4.60. There was no evidence that CPT Ltd carried out assurance activities of the further-sub-contractor other than receiving documentation and passing it to QinetiQ. There was no evidence that QinetiQ conducted assurance activity upon receipt of G-YAKB's airworthiness documentation except for filing it. The pertinent points about the documentation were as follows:

- a. QinetiQ personnel took delivery of G-YAKB's Permit To Fly (PTF) and Certificate of Validity (CoV), which was held by Procurement. QinetiQ Procurement and the ETPS PM assumed that the airworthiness documentation would be checked by the QinetiQ airworthiness team but did not request advice from SMEs to confirm that G-YAKB was airworthy or correctly certificated for aerial work. QinetiQ Procurement staff did not possess the relevant competences to know the difference between a PTF aircraft or one with a Certificate of Airworthiness (COA).
- b. QinetiQ Airworthiness was provided with the flying programme for the week. As the operations of G-YAKB were owned by the PIC no one within QinetiQ was responsible for ensuring that G-YAKB was airworthy. As the aircraft was being provided as a contracted service, QinetiQ Airworthiness considered that it would be delivered in an airworthy condition; therefore, there was no need to assure this. There was no QinetiQ Airworthiness involvement in Yak QE. As a PTF aircraft the airworthiness of G-YAKB was the responsibility of the owner, until this responsibility transferred to the PIC. A QinetiQ employee demonstrated that he was aware that a

Witness 25  
Witness 29

Witness 30

Witness 31

<sup>31</sup> SQEP can be used to mean Suitably Qualified and Experienced Personnel or Person.



PTF aircraft carried a higher level of risk to that of an aircraft with a COA.

c. The MOD chain of command had 2 sources of airworthiness assurance: the AWC Chief Air Engineer (CAE) and the QinetiQ Head of Airworthiness.

Witness 21  
Witness 23

d. The AWC CAE TORs contained no mention of assurance of third party aircraft. The MOD had no independent means of assuring itself that the aircraft was airworthy.

Exhibit 52

1.4.61. The personnel who received the airworthiness documentation for G-YAKB were not SQEP and therefore did not understand the content and consequences of the document set. G-YAKB's documents were not relayed to someone who was a SQEP to scrutinise them, although such SQEP existed at Boscombe Down. Personnel from QinetiQ Airworthiness and the MOD conducted no assurance of the document set. The MOD chain of command was reliant on QinetiQ Airworthiness to advise the CAE or the Chief Test Pilot that the aircraft was airworthy. In this case, as QinetiQ Airworthiness saw no reason to become involved with Yak-52 QE nor were they consulted for expert opinion, the MOD had no means of assurance.

Exhibit 61

Exhibit 3  
Exhibit 61  
Exhibit 62  
Witness 21

1.4.62. The MOD's process, which was reliant on QinetiQ and did not provide independent assurance of the third party aircraft's airworthiness was an **Other Factor**. (An associated recommendation is put forward in paragraph 1.4.66).

### Insurance

1.4.63. The Framework Agreement required the sub-contractor to be insured. Insurance was also required to operate from BDN. When permission was sought for the PIC to arrive at BDN on Sun 3 Jul 16 it was noticed by a QinetiQ employee in Operations that the transit sortie was not covered by the insurance documents held by QinetiQ. This was rectified before the transit flight took place when documents were sent by the PIC to ETPS from where they were forwarded to BDN Ops. When G-YAKB arrived at BDN it had 2 certificates of insurance:

Exhibit 2  
Exhibit 63

Witness 32

a. For the period 2 Jul 16 to 1 Jul 17 covering 5 named pilots "..., *subject to having at least a minimum of 100 fixed wing piston engine hours. In addition, whilst giving instruction to the aforementioned pilots, any qualified flying instructor/examiner is automatically included as an approved pilot hereon.*" The PIC was not one of the 5 named pilots; the ETPS phase tutor who conducted the transit sortie was one of those named. QE sorties were training evolutions but not instructional sorties and the PIC did not instruct whilst at ETPS. His role was to ensure that the QE activity remained within the permitted aircraft flight envelope.

Exhibit 64

Witness 11  
Witness 24

b. For the period "...with effect from the 4th July to 8th July 2016 cover.....Uses: *Club; Pilots: as approved by the insured*"<sup>32</sup> The owner (the Insured) approved the PIC's use of the aircraft. The Panel has not been given any evidence of the owner (the Insured) approving QE participants' flights in G-YAKB.

Exhibit 64  
Exhibit 65  
Exhibit 12

1.4.64. It was not clear to the Panel whether the insurance requirements identified in the Framework Agreement were appropriate for the activity. It was also not clear to the Panel whether the policies were valid for the activity. Whether the PIC had an instructional capacity on the transit flight or 'Club Uses' covered the QE activity, or if ETPS participants

<sup>32</sup> The insurers of G-YAKB, Haywards Aviation Ltd, supplied the Panel with the following definition of Club Uses: 'Use for private business and pleasure purposes including all forms of instruction and for the Insured's business or profession, and/or aerial photography and/or rental, lease, hire or charter by the Insured to any person, company or organization for Private Business and Pleasure uses only, rental to Club members, all forms of instruction including ab-initio instruction, the carriage of passengers for hire or reward, parachuting and glider towing.' Exhibit 64.

had been approved by the insured were all unclear. The Panel found no evidence that the specifics of the insurance were scrutinised by SQEP or that advice or clarification was sought by anyone attempting to confirm that the insurance was valid. The lack of insurance for the transit flight, noticed by MOD Boscombe Down Operations, presented an opportunity for the insurance document set to be checked in its entirety; however, this opportunity was not taken. A system was not in place, whereby the contracted ATO provided the entirety of the documentation for G-YAKB and the PIC to a single point of contact within QinetiQ. This would have allowed for storage within a single repository and dissemination to SQEP for scrutiny and approval. The management of the LCB and the sourcing of documents from people other than the ATO created a situation where no single person had visibility of, or responsibility for, the entire document set. QinetiQ informed the Panel that whilst the Company required any contractors to provide insurance, its own Aviation Liability insurance policy, subject to the limits of insurers' liability, provided liability cover for bodily injury and property damage and would be applicable to the cover the associated activity.

Witness 30

Exhibit 66

1.4.65. It was unclear from the available documentation whether the insurance requirements for QE were appropriate for the activity or if the insurance arranged for the use of G-YAKB during the ETPS QE week by the PIC was valid for the activity. QinetiQ had in place insurance that covered the activity in any case. Notwithstanding this, the process that QinetiQ and MOD used did not ensure that SQEP scrutinised G-YAKB's insurance documents, with the result that they could not demonstrate that the accident sortie was insured; this was an **Observation**.

1.4.66. **Recommendations:**

- a. The D MAA should put in place a requirement for assurance activity to be conducted by Suitably Qualified and Experienced MOD Personnel of the documentation of third party aircraft hired by MOD, or a defence contractor, for Defence activity.
- b. QinetiQ should ensure that all documentation pertaining to the operation of a third party aircraft at ETPS is filed within a single repository, in order to provide a clear auditable record.

### G-YAKB SUITABILITY FOR QUALITATIVE EVALUATION

#### Aerial Work

1.4.67. G-YAKB had a PTF rather than a COA. CAP 733 stated the following with respect to PTF aircraft:

*"Due to the reduced airworthiness status, to ensure that an adequate level of safety is maintained, additional limitations and conditions will be placed upon the operation of these aircraft."*

Exhibit 45

1.4.68. The ANO contained the following at Section 1: Part 3:

*"23 Limitations of national permits to fly*

Exhibit 5

*(1) Subject to paragraph (3), an aircraft flying in accordance with a national permit to fly must not fly for the purpose of:*

*c. aerial work other than aerial work which consists of flights for the purpose of flying displays, associated practice, test and positioning flights or the exhibition or demonstration of the aircraft.*

**OFFICIAL SENSITIVE**

*No person may be carried during flights for the purpose of flying displays or demonstration flying (except for the minimum required flight crew), unless prior permission of the CAA has been obtained."*

1.4.69. The Panel was informed by CAA, through AAIB, that in accordance with General Exemption E 4135 in the ANO, G-YAKB as a Yak-52, is classified as an ex-military aircraft<sup>33</sup> and should have had the following placard fitted<sup>34</sup>:

Occupant Warning:

THIS AIRCRAFT HAS NOT BEEN SHOWN TO COMPLY  
WITH CIVIL SAFETY STANDARDS FOR  
COMMERCIAL PASSENGER FLIGHTS.  
IT IS ILLEGAL TO CARRY PASSENGERS ON THIS AIRCRAFT  
IN EXCHANGE FOR MONEY, GOODS OR SERVICES.  
COST SHARING IS PERMITTED.

1.4.70. G-YAKB's PTF paragraph 5.2 stated that: "*The minimum flight crew is: One pilot(s).*" No application to conduct aerial work in a Yak-52 had been received by the CAA. No application for the permission required by the ANO to carry persons on demonstration flights had been made in respect of G-YAKB. CPT Ltd believed that the aerial work was permitted as demonstration flying in accordance with their understanding of Article 23 of the ANO. Despite having not read ANO Article 23, the PIC thought that demonstration flights in PTF aircraft were permitted. His belief was based upon hearsay and that the Yak-52 QE had been organised through professional organisations. The aircraft owner believed that the operation of the aircraft and his remuneration were appropriate based on the end user being the military. Liaison with the CAA has concluded that G-YAKB, a PTF aircraft, in carrying a person other than the minimum required crew (noted as "One pilot(s)" on G-YAKB's PTF) on a demonstration flight without CAA permission, contravened Article 23 of the ANO. A demonstration flight is not defined in the ANO; however, the CAA informed the Panel that QE activity could have been considered to be a demonstration flight. Whilst G-YAKB was capable of conducting the QE sortie profile, it was not certificated for aerial work and MOD Boscombe Down did not hold sufficient documents to demonstrate that the sorties conformed to the ANO. In discharging a Duty of Care both QinetiQ and the MOD chain of command, were responsible for assuring themselves that the aircraft was airworthy and correctly certificated.

1.4.71. The QE service contracted by QinetiQ for an ETPS requirement was delivered using an aircraft with a PTF. As a PTF aircraft its maintenance was the responsibility of the owner; there was no requirement for its airworthiness to be monitored or assured by a certified Contractor Approved Maintenance Organisation. The PTF aircraft was precluded from conducting aerial work other than those forms of aerial work for which exemptions were granted. QE was not included in those exemptions however demonstration flights were. The term 'demonstration flight' was not defined in the ANO. Even if QE were to be considered a demonstration flight, the ANO still required permission to be sought for an extra person to be carried. As permission had not been sought to conduct aerial work or carriage of persons on a demonstration flight, its use during QE contravened Article 23 (2) of the ANO. Stakeholders are justified in assuming that others are acting lawfully and in believing that a contractor will act lawfully, particularly if this is a contractual obligation. Whilst both MOD and QinetiQ could reasonably expect the aircraft to be operated legally the

Exhibit 67

Exhibit 3  
Exhibit 68

Witness 24

Witness 11

Exhibit 68

Exhibit 45

<sup>33</sup> Notwithstanding the CAA's categorisation of the aircraft as ex-military, the Yak-52 was used by the Volunteer Society for Cooperation with the Army, Aviation and Fleet or DOSAAF, which trained both military and sports pilots. If this history was interpreted to mean that the Yak-52 was not an ex-military aircraft G-YAKB would have complied with the ANO by carrying simpler placards stating that "This Aircraft Has Not Been Certified To An International Requirement". Two placards stating as much were found in the wreckage.

<sup>34</sup> Official record Series 4, No:1149, Publication date: 07 Jan 16.



assurance of airworthiness documentation provided the opportunity to discover that it was not. In other areas QinetiQ demonstrated that assurance activity was desirable to them through seeking pertinent aircraft documentation; however, in reality the Company only received and stored the information instead of having it scrutinised by SQEP. The assumption that QE in G-YAKB was compliant with the ANO without sufficient assurance activity by any stakeholder led to ETPS using the services of an aircraft that was being operated in contravention of the ANO.

1.4.72. Having considered the situation with respect to Aerial Work, the Panel came to the following conclusions:

- a. Permission to conduct aerial work or to carry an extra person during a demonstration flight in G-YAKB had not been granted by the CAA, which contravened Article 23 of the ANO. This was an **Other Factor**.
- b. The process that QinetiQ used, which did not ensure that any SQEP received and scrutinised G-YAKB's airworthiness documents, removed an opportunity to discover that ETPS personnel were to fly in an aircraft that was operating in contravention of the ANO was an **Other Factor**.
- c. No permission had ever been sought from the CAA for a Yak-52 to conduct aerial work, to carry extra persons on demonstration flights, or for activity under CAP 1395 Safety Standards Acknowledgement and Consent<sup>35</sup>, which indicated to the Panel that no Yak-52 QE had ever been adequately scrutinised. This was an **Observation**.
- d. A PTF was unavailable to aircraft where the type qualified for a COA; therefore, all the Yak-52 activity that had been conducted in support of ETPS must have used PTF aircraft which was an **Observation**.

Exhibit 5

#### G-YAKB Engine Maintenance Regime

1.4.73. G-YAKB had a 24 year old M-14P engine which had been fitted during production and that had never been overhauled. The M-14P engine had a 2250 hr finite operating life with an overhaul being required at 750 hrs<sup>36</sup>. The hours run in the engine log book were not up to date at the time of the accident but on 12 Feb 16, as part of the annual service documentation process, they were certified as 495.13 hr.

Exhibit 69

Exhibit 70

1.4.74. None of the evidence provided to the Panel indicated that anyone at CPT Ltd, QinetiQ or the AWC had reviewed the aircraft log books or considered the condition of the engine. Had supervisors known that G-YAKB had a 24 year old engine which had never been overhauled, it might have led to a review of Yak-52 QE.

1.4.75. The reliance on CPT Ltd to provide an airworthy aircraft that was fit for purpose without sufficient assurance, denied supervisors an opportunity to understand the maintenance regime for G-YAKB and any associated risk, was an **Other Factor**.

#### Yak-52 Rear Seat Controls

1.4.76. The Yak-52 was a tandem seat training aircraft. It had a flat tandem cockpit with both the front and rear occupants at approximately the same eye height whilst in level forward flight as shown at Figure 1.4.1. Figure 1.4.2 shows the front cockpit instruments and Figure 1.4.3 the rear cockpit instruments. The main flight instruments and controls are

<sup>35</sup> Which allows fee-paying passengers to experience flight in vintage aircraft subject to conditions being met.

<sup>36</sup> MPD 1998-001 R2.

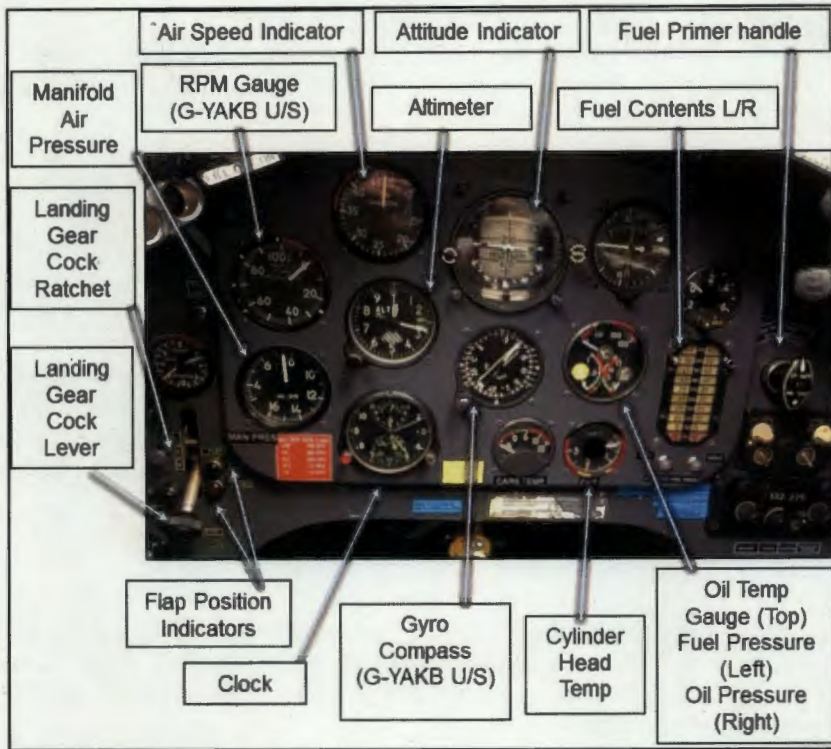

Figure 1.4.2 Front Cockpit Instruments<sup>37</sup>

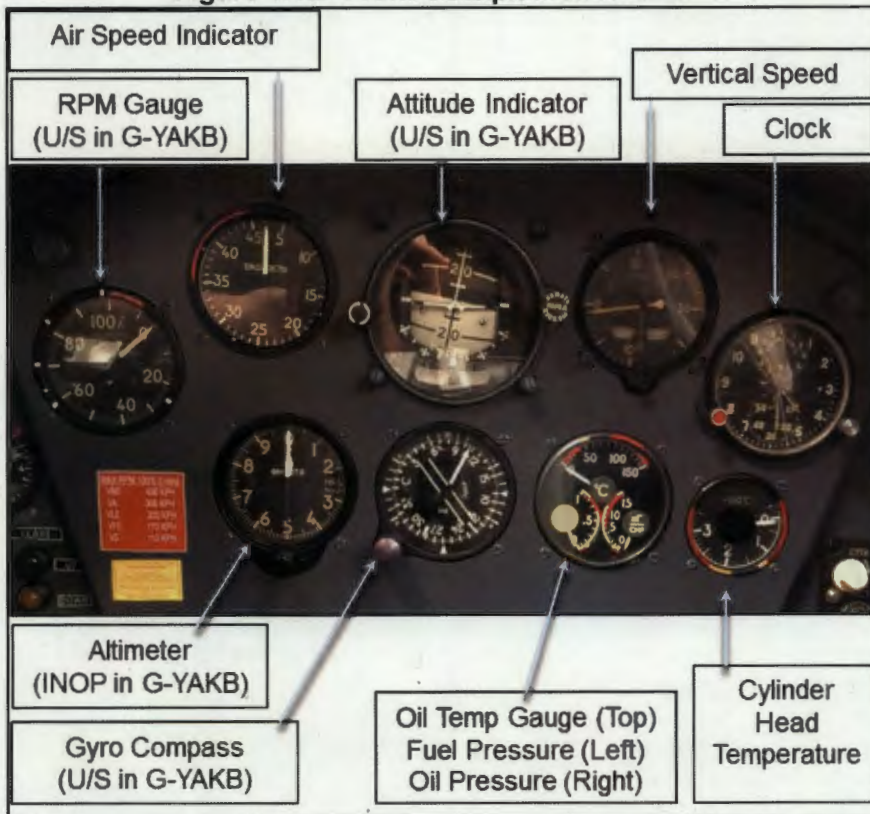

Figure 1.4.3 Rear Cockpit Instruments

<sup>37</sup> U/S is an abbreviation of 'Un-serviceable'.



identical to those in G-YAKB. The Yak-52 front and rear cockpits contained different scales of instruments and controls. For example, the fuel primer handle is only located in the front cockpit; only the front seat occupant could operate this control.

1.4.77. The differences in instrumentation between cockpits meant that the pilot in the rear cockpit had different situational awareness to someone in the front cockpit. The 2 pilots also had different controls. In the accident sortie the PIC occupied the rear cockpit and did not have all instruments and controls available to him, eg there is no Manifold Air Pressure (MAP) gauge in the rear cockpit. The full controls and remaining serviceable instruments were in the front cockpit occupied by the unqualified<sup>38</sup> FSP. During the week of the accident there were 4 QE sorties when the PIC's seating position was swapped to the front cockpit to suit the role of the training flight. In these sorties the Flight Test Engineer (FTE) was in the rear seat and the PIC in the front cockpit, as stipulated in the Framework Agreement and indicating that he was best placed to act as Aircraft Commander from the front cockpit.

Exhibit 2

### Selection of the Yak-52

1.4.78. The Yak-52 was selected for QE in order to expose TPS and FTE students to the cockpit and system design philosophy of an Eastern European aircraft and the handling qualities and aircraft operating techniques associated with such a design. As a Russian designed aircraft the Yak-52 was built with design differences to most western aircraft; for example it utilised pneumatic services.

Exhibit 2

Witness 20

1.4.79. There were other aerobatic capable twin seat aircraft available; however, it was the express intention of QE to expose a FTE, TP or TPS to unfamiliar aircraft. The Russian design, use of metric units for airspeed and limited Cyrillic labelling in a Yak-52 achieved this objective.

Exhibit 46

1.4.80. The ability of a Yak-52 to carry a Safety Pilot, whilst at the same time exposing FTEs, TPs and TPSs to an alien cockpit environment, identifiable handling characteristics and a suitable flight envelope, suit the aircraft type to QE. It was an **Observation** that there were other aircraft types available that could have been considered to fulfil the role of Fixed Wing (FW) QE but to identify one that was a better choice than the Yak-52 was outside the scope of the Inquiry.

1.4.81. **Recommendation.** QinetiQ should conduct an assessment of the use of alternative aircraft types to deliver QE training aims, to determine whether a more suitable aircraft could be identified.

### G-YAKB SERVICEABILITY

#### Maintenance History

1.4.82. G-YAKB was placed on the UK register in 2002. Owner maintenance on the aircraft had been supplemented by a regime of annual maintenance that had been carried out by a number of CAA approved maintenance organisations.

Exhibit 71

a. G-YAKB did not fly between 30 Aug 08 and 24 Sep 13.

Exhibit 71

b. In Jul 13 an airframe life extension was granted until Jun 2023, or 1030:33 flying hours following the completion of the maintenance activity specified in CAA Mandatory Permit Directive No 1998-017 R5.

Exhibit 72

<sup>38</sup> The report will use the term 'unqualified' to mean unqualified on that specific aircraft type.



c. In Feb 16 the annual maintenance activities required by the CAA Light Aircraft Maintenance Schedule (LAMS)<sup>39 40</sup> for G-YAKB were completed and a Certificate of Validity was issued endorsing the continuance of the Permit to Fly for the aircraft. The maintenance and over-signature activity were undertaken by CAA approved organisations.

Exhibit 73

Exhibit 4

d. G-YAKB's Airframe and Engine Logs remained with the aircraft engineering company that completed the annual maintenance activity in Feb 16 and were not seen by any MOD personnel or QinetiQ employee prior to QE.

Exhibit 74

### Rear Cockpit Altimeter

1.4.83 The rear seat altimeter in G-YAKB was inoperative and placarded<sup>41</sup> 'INOP'. The inoperative state of the altimeter was recorded in the aircraft logbook. The Panel were not told that the inoperative state of the rear altimeter was briefed to the ETPS students and no ETPS FTE student interviewed noticed that the altimeter was unserviceable or that it was placarded. The altimeter was not physically inoperative but had failed an accuracy test.

Exhibit 71

Exhibit 75

1.4.84. It was most likely that the altimeter appeared to function correctly but may have supplied erroneous altitude information to the PIC. In a Forced Landing a pilot will use a blend of external look out and internal scan of instruments. For a Forced Landing away from an airfield, where the precise height of terrain was not known and a Regional Pressure Setting was being used, this would probably have been biased towards the external look out; however, it was possible that erroneous height information was supplied by the placarded altimeter to the PIC during the Forced Landing.

### Gyro Compasses

1.4.85. G-YAKB arrived with gyro compasses that would not slave (align to North) and could not be manually aligned. The gyro compasses may have displayed incorrect heading information<sup>42</sup>. The failure of the gyro compasses was noticed by the PIC and reported to the owner, who had known about it previously. The failure was not noticed by the FW tutor who flew the ferry flight to MOD Boscombe Down with the PIC or briefed to ETPS students prior to QE. The aircraft had a serviceable wet compass in both cockpits. At the last radar position G-YAKB's heading was approximately 30 degrees divergent from the track to BDN. G-YAKB impacted the ground down wind.

Exhibit 76

Exhibit 19

1.4.86. It is not possible to say whether the accident FSP received a brief on the unserviceability of the gyro compasses. It is likely that, as with the other QE participants, he did not. The gyro compass occupies a central position on the instrument panel of both cockpits (Figures 1.4.2 and 1.4.3). In this location it presents a compelling cue to the pilot of the aircraft's heading and from it the wind relative to the aircraft. An unslaved compass could give erroneous heading information. The crew, despite operating under Visual Flight Rules (VFR), requested a radar vector to Boscombe Down from ATC. This may have indicated that they were unable to orientate themselves for recovery using the available means in the prevailing conditions. This is further evidenced by them steadying initially on west, then south before turning to an easterly heading. Alternatively the request for a radar

Exhibit 21

Exhibit 19

<sup>39</sup> The LAMS specifies a generic set of overhaul, additional inspections and test periods for aircraft and helicopters not exceeding 2730 Kg Maximum Total Weight Authorised (MTWA) that are not supported by original type design organisation maintenance regimes.

<sup>40</sup> Within LAMS, maintenance activities are variously described as 'Service/Lubrication', 'Inspect', 'Check', 'Operational Check', or 'Functional Check'.

<sup>41</sup> Large capital letters painted on the face of the instrument.

<sup>42</sup> The compasses may have aligned to North by chance.

vector may have been personal habit pattern or due to ground features being obscured by cloud. The unserviceable gyro compasses could have been a distraction to the accident crew and may have increased their work load in identifying an into wind landing surface. The inability to slave the gyro compasses was noticed by ETPS students; however, it was not reported. The lack of this feedback prevented ETPS supervisors from querying the serviceability of G-YAKB. Had the unserviceability been reported it is more likely that pilots, including the accident FSP would have been informed of it. This would have allowed the FSP to note the unserviceability, discuss it with the PIC and consider its implications prior to flight, thereby reducing any potential effect on his decision making in flight.

Exhibit 77  
Witness 2  
Witness 3

### **RPM Gauges**

1.4.87. There is an RPM gauge in both cockpits of the Yak-52. The rear cockpit lacks a MAP gauge. The rear cockpit RPM gauge is a repeater of that in the front cockpit. These are the only engine performance instruments available to the aircrew. Both cockpits have a 'tri-gauge' showing Oil Pressure, Oil Temperature and Fuel Pressure on 3 separate scales on a single gauge (Figures 1.4.2 and 1.4.3.) Both cockpits also have a Cylinder Head Temperature (CHT) gauge. The tri gauge and CHT gauge are indicators of engine parameters. The RPM gauges in both cockpits were noticed by the PIC and QE participants to be unserviceable during the QE week as described below.

Exhibit 78

a. The RPM gauges exhibited 2 failure modes. The first was a zero indication; the second was an incorrect reading accompanied by incorrect counter clockwise movement indicating an increased RPM, i.e. the gauge operated backwards. Two QE participants report the gauges showing zero. In one of these cases the gauge subsequently appeared to work later in the sortie. Two further participants witnessed the RPM gauges working backwards. One further participant witnessed both failure modes.

Witness 6  
Witness 5  
Witness 3  
Witness 4  
Witness 2

b. The unserviceable RPM gauges were reported by the PIC to the owner by e-mail on 5 Jul 16, the second day of QE. The PIC identified that the RPM indication intermittently failed, estimated that a 20 min repair was required but stated that local technicians did not want to take on the task. The PIC went on to say that the fault was not causing him any problems and that he would provide a verbal indication of the RPM to pilots.

Exhibit 79

c. The unserviceable RPM gauges were discussed by the PIC with a QinetiQ employee who reported to the Panel that the fault was an intermittent failure with the gauges reading zero, then showing either correct indications or working backwards before reading zero again.

Witness 29

d. The unserviceable RPM gauges were not reported to any ETPS supervisor during QE week.

Exhibit 80

e. The Minimum Equipment List (MEL)<sup>43</sup> for the Yak-52 did not include serviceable RPM gauges.

1.4.88. The PIC reported that the RPM gauges had failed by the time of the accident sortie but noted that his recollection may be incorrect. It is possible that upon engine start on 8 Jul 16 the RPM gauges functioned correctly, however, they had exhibited one or both of their failure modes on the 4 previous sorties and no maintenance had taken place to rectify the fault. It is therefore probable that the RPM gauges were not serviceable for the accident sortie. The RPM gauge and the MAP gauge were the only engine performance instruments

Exhibit 145

<sup>43</sup> As supplied to the Panel by the CAA as 'ANO Minimum Equipment for VFR Operations'.



available to the crew and the rear cockpit had no MAP gauge. Thus, 2 out of 3 engine performance instruments were unavailable and no performance indicator was available to the PIC. The relationship between RPM, how fast the propeller is spinning, and the MAP (how much air is being demanded by the engine relative to ambient air pressure) are key to engine management, fuel management and engine malfunction diagnosis. It is possible to set the engine RPM to a very coarse degree by muscle memory, RPM lever position or noise signature but it is not possible to do this accurately. The RPM lever is exercised pre-take off in the Yak-52 and the RPM drop associated with isolating magnetos is also checked. The tolerances required in the Aerostar manual are +/- 3%. It is impossible to carry out this procedure to the tolerances required in the Aerostar manual without a RPM gauge. It is also impossible to confirm that the aircraft engine stays within published RPM limits (given in the Aerostar manual as +/- 1%) during a sortie without a working gauge. It is the Panel's opinion that without this critical instrument G-YAKB should not have been considered serviceable for flight.

Exhibit 81

Exhibit 82

1.4.89. The RPM gauge malfunction had been explained to ETPS students by the PIC, along with his plan to overcome the issue. It is likely that he briefed the same with the accident FSP. The pre-take off checks in the Yak-52 require the RPM lever to be exercised which the FSP would have either monitored or conducted. It is probable that the FSP was aware of the serviceability of the RPM gauges pre-launch.

Witness 3  
Witness 6

#### Rear Cockpit Attitude Indicator

1.4.90. Two ETPS FTE students reported to the Panel that the rear seat Attitude Indicator (AI) was not serviceable and that the instrument did not display a steady useable horizon. There was no evidence that any repair was carried out on the rear seat AI after it was noted as being unserviceable by QE participants. There was no evidence that the unserviceability of the rear AI was brought up in an out-brief or in-brief.

Witness 3  
Witness 4

1.4.91. Whilst it was unlikely that the PIC would rely upon the AI in the execution of a FL in VMC, it was not possible to discount that the failed AI would have been a distraction to the PIC both during emergency diagnosis and subsequent emergency handling. A distraction in these stages of flight would have made accurate diagnosis and accurate handling less likely.

Exhibit 77

#### Front Seat Pilot's Headset

1.4.92. The Framework Agreement between QinetiQ and CPT Ltd required the sub-contractor to supply headsets. The Bose headset worn by the FSP was a replacement supplied by the PIC. The original item used at the start of the QE week was replaced on 6 Jul 16 during the crew-in for a student sortie. Witnesses report that there had been an intermittent technical fault with the communication system in the initial headset. This had led to difficulty in using both intercom and radio. Technical assistance was provided by a QinetiQ employee. Students reported that frayed wires within the headset had been repaired with tape. This repair resulted in the item still being unserviceable and the Bose headset was substituted for it.

Exhibit 2

Witness 3  
Witness 6  
Witness 29

#### Multiple Instrument Failures

1.4.93. The PIC operated an aircraft with recurring malfunctions, which were considered by ETPS Supervisors, in retrospect, and the Panel to have reduced Flight Safety. The RPM gauge failure which required the PIC to estimate RPM settings in normal operations, with unknown consequences to the engine, made accurate RPM assessment in an emergency impossible. The Panel was of the opinion that the QE flight should not have taken place without a serviceable RPM gauge. Flight with a failed rear seat AI and gyro compasses that would not slave may have caused a distraction to the PIC, confused the PIC or increased his workload in an emergency. Whilst unlikely, it is possible that the PIC was receiving



erroneous altitude from the placarded altimeter. The combination of failed gyro compasses, placarded Altimeter, failed AI and failed RPM gauges would have denied the accident crew Situational Awareness and probably introduced distraction and confusion into an emergency. The Panel concluded that flight with multiple instrumentation failures was a **Contributory Factor**.

1.4.94. The ANO required an Aircraft Commander to be responsible for ensuring that the aircraft *"is in every way fit for the intended flight"*. The ANO does not define 'fit for flight'. ETPS supervisors stated that the RPM gauges were critical items. The malfunction of the aircraft RPM gauges, rear cockpit AI, gyro compasses and headset had been noted by multiple ETPS students during the QE week. This should have been reported to ETPS supervisors through a formal reporting system (ASIMS for ETPS personnel) but was not. Without the feedback that the PIC was flying with multiple malfunctions ETPS supervisors were denied a trigger to query the PIC's conduct, suggest a change in that conduct, and to ultimately order the cessation of QE until the aircraft was *"fit for the intended flight"*. The Panel considered it probable that ETPS supervisors would have ordered a cessation or pause in QE if they were informed of the malfunctions.

Exhibit 5  
Exhibit 83  
Witness 31

### THE CREW OF G-YAKB ON 8 JUL 16

#### Front Seat Pilot

1.4.95. The FSP had not completed his RAF Pilot's logbook for Jun 16; however, the missing sorties were recorded in the ETPS database. At the time of the accident the FSP had flown 5773:45 hr whilst on duty of which 603:55 hr were in SEP aircraft. The FSP had also logged 518:45 hr of civilian flying. The FSP had flown 197:55 hr on duty in the 12 months prior to the accident, of which 57:00 hr were in the 3 months prior to the accident. The FSP had also flown 6:20 hr of civilian flying in the year prior to the accident, of which 5:20 hr were in the 3 months prior to the accident. The FSP's logbooks did not record any Yak-52 flights indicating that he had not flown the aircraft type before the accident flight.

Exhibit 88  
Exhibit 89  
Exhibit 90

1.4.96. The FSP had last flown on 7 Jul 16 and was 'Green'<sup>44</sup> on ETPS currency tracker which included Human Factors and Crew Resource Management (CRM) training.

Exhibit 13

1.4.97. The FSP had sufficient recent currency in a variety of aircraft. He was very experienced and although unfamiliar with the Yak-52, he had sufficient Class experience, Captaincy and Crew Resource Management skills to affect the flight of G-YAKB as a crew member, especially during the final stages of the Forced Landing. Without a Flight Data Recorder (FDR) the Panel could not determine how the FSP used his attributes during the sortie and in particular during its final stages.

1.4.98. The FSP was a highly experienced and current SEP pilot; however, he was unfamiliar with the Yak-52 and the extent of how this aviation experience and currency affected the final stages of the accident flight was not known.

#### Pilot in Command

1.4.99. The PIC held a valid Commercial Pilot's Licence (CPL) with SEP (Land) rating, Instrument Rating (IR) and Flight Instructor (FI) rating. The PIC had not read Article 23 of the ANO.

Exhibit 84  
Witness 11

1.4.100. The PIC's logbook was not checked by CPT Ltd, QinetiQ or AWC personnel. The PIC's experience was as follows:

Witness 24  
Witness 1

<sup>44</sup> Indicating currency using local metrics.

- |   |  |
|---|--|
| <p>a. He had renewed his SEP rating with an IR on 13 May 15 and had renewed his FI rating with a skills check on 17 Mar 16.</p>   | <p>Exhibit 84</p>                              |
| <p>b. He had logged a total of 2953:15 hr at the time of the accident, 39:05 hr in the year before the delivery flight and 6:55 hr in the 3 mth before the delivery flight.</p>   | <p>Exhibit 86</p>                              |
| <p>c. The PIC had 446:55 hr of Yak-52 experience of which an estimated 80% was in the front seat.</p>   |  |
| <p>d. The PIC had flown in the back seat of Yak-52 G-BVXK on 16 Mar 16 as PIC for an instructional sortie. This sortie took 1:00 hr and was the PIC's only logged Yak-52 flight between the 2014 QE and the 2016 QE delivery flight. The PIC did not log the 2015 QE; however, the flights were recorded in the ETPS database. The owner of Yak-52 G-BVXK recorded the PIC's presence on sorties on 24 Feb 16, 20 Apr 16, 20 May 16 and 30 Jun 16, in addition to the sortie flown on 16 Mar 16. The owner reported that on 30 Jun 16 the PIC had flown a single landing from the rear cockpit.</p> | <p>Exhibit 146</p>                             |
| <p>e. The PIC had flown 9:30 hr during the 2016 QE week.</p>  |  |
| <p>1.4.101. The Panel noted in relation to the PIC's experience that:</p>   |  |
| <p>a. There is no definition of, or currency minimum for, QE PIC/Safety Pilot. The Framework Agreement stated that the "Aircraft Captain" must be a CAA/EASA-qualified FI (Unrestricted) or a Class Rating Instructor.</p>  | <p>Exhibit 2</p>                               |
| <p>b. The minima for renewal of a SEP (Land) type rating was either a Skills Test or 12 flying hours in the 12 months before renewal date plus one hour of flight with an instructor<sup>45</sup>. Renewal was required every 2 years<sup>46</sup>. An FI rating had to be renewed every 3 yrs by completing '2 out of 3' of the following: attending a seminar, 50 hr instructional time or a Skills Test.</p>   | <p>Exhibit 85</p>                              |
| <p>c. ETPS used an Aviation Task Risk Matrix (ATRM) to identify supervisory risk. If a pilot had greater than 3 flying hours in 7 days, 12 hours in 31 days and 30 hours in 90 days, he was considered not to represent a supervisory risk. Failure of one criterion was considered to add supervisory risk and failure of more than one required authorisation of the sortie by a senior supervisor. ATRM use was considered in paragraph 1.4.134.</p>   | <p>Exhibit 87</p>                              |
| <p>d. ETPS management and supervisors held the belief that the possession of civilian qualifications was sufficient assurance of the PIC's competence. There was no evidence that work went into understanding the difference between civilian and military qualifications and currency or any associated risk.</p>   | <p>Witness 22<br/>Witness 21<br/>Witness 1</p> |
| <p>1.4.102. The MOD uses a combination of flying hours and periodic skills practice and tests as an assurance of a pilot's competence. Whilst the PIC had flown sufficient hours in an appropriate timescale to renew his ratings, his hours in recent months were, as measured by the ETPS ATRM, sufficiently low to have been considered a supervisory risk both at the commencement of QE and for the accident sortie. The PIC's single logged Yak hour between 2015 QE and 2016 delivery flight was not brought to the attention of ETPS</p>  |  |

<sup>45</sup> <https://www.caa.co.uk/General-aviation/Pilot-licences/EASA-requirements/Ratings/Single-engine-piston-rating-for-aeroplanes/> accessed on 15 Mar 17.

<sup>46</sup> <http://www.caa.co.uk/Commercial-industry/Pilot-licences/Applications/Ratings/What-to-do-if-a-rating-is-about-to-expire/> accessed on 15 Mar 17.

supervisors; however, his hours were not filled out accurately on the ATRM, so his recent flying experience was not displayed to ETPS supervisors. This level of currency on type was probably sufficiently low to reduce the PIC's competence to operate the Yak-52. Had this been brought to the attention of supervisors, it is likely that a review of QE would have taken place.

1.4.103. The PIC was qualified to operate the Yak-52 in accordance with civilian requirements; his recent flying hours which were much lower than the guidelines within the ETPS ATRM, were not known or risk assessed by supervisors which was an **Other Factor**.

1.4.104. **Recommendation.** The Chief Test Pilot should ensure that the QE safety case includes a description of the PIC's qualifications and experience, and that their currency is assessed against the ETPS ATRM in order to identify risk.

**The Pilot in Command in the Role of Safety Pilot**

1.4.105. There was no CAA or EASA mandated currency for a Forced Landing but the demonstration of one was usually included in skills checks. As a comparator the Air Experience Flight (AEF) at BDN used a 90 day minimum for Practice Forced Landing (PFL) currency<sup>47</sup>. The PIC stated in his formal interview that he would normally conduct a PFL to a minimum of 500ft. The PIC had flown a sortie on 15 May 16 in a PA-28 as a FI that would ordinarily include a PFL. As a FI this sortie involved the PIC supervising the other pilot flying a PFL. The FI renewal profile flown by the PIC on 17 Mar 16, in a Bellanca 8KCAB included a PFL from height. On 16 Mar 16 the PIC monitored another pilot flying a PFL in a Yak-52. The PA-28 and 8KCAB both have higher Glide Ratios<sup>48</sup> than the Yak-52, which has a published Glide ratio of 7:1. The PIC had flown 3 previous successful Forced Landings in Yak-52s following actual emergencies.

Exhibit 85  
Exhibit 91  
Witness 11

1.4.106. It was most likely that the FI renewal sortie flown on 17 Mar 16 was the last time the PIC had flown a PFL himself, albeit in a different aircraft type, rather than monitoring someone else flying one. This was 113 days before the accident sortie and was not in the rear seat of a tandem aircraft. The PIC's last PFL as handling pilot was in an aircraft with significantly better gliding performance than the Yak-52. The PIC, in conducting PFLs to 500ft<sup>49</sup> would not experience the full profile of landing an aircraft without power. The final stages of a PFL executed to either a full stop or roller landing provide a pilot with valuable experience of ground rush, landing attitude without power, energy management and allow for a more accurate assessment of whether the landing would have been a success.

Exhibit 92  
Witness 11

1.4.107. The PIC's lack of recent PFLs and currency reduced his ability to carry out a successful Forced Landing and was a **Contributory Factor**.

**The Pilot in Command's Forced Landing Plan**

1.4.108. The PIC initially reported that he always briefed that the FSP would land a Forced Landing due to him only being able to see out of the sides of the rear cockpit. The PIC subsequently stated that he would retain control in a Forced Landing and his plan to handover control was one that he would use only if the FSP was an experienced Yak pilot. When asked about emergency handling, no ETPS supervisor or student brought the PIC's intention to handover control in a Forced Landing to the Panel's attention. This indicated that it was not briefed to all FSPs that they would land the aircraft in the event of a Forced

Witness 11  
Exhibit 147

<sup>47</sup> ie To be considered current one must have flown a PFL in the preceding 90 days.

<sup>48</sup> The ratio of still air horizontal travel to height loss in a straight line glide descent at the correct speed.

<sup>49</sup> The ANO requires 500ft Minimum Separation Distance.



Landing; however, the 2 pieces of evidence from the PIC were conflicting and the subsequent statement was given 9 months after the crash. Whilst not a qualified Yak-52 pilot the FSP was an experienced TP. The Panel considered it probable that the PIC did plan to hand over control to the FSP in a Forced Landing. The contents of QE emergency briefs are considered in paragraph 1.4.130.



**Figure 1.4.4. Yak-52 Front cockpit Field of View (FOV) forward (180° panoramic)**



**Figure 1.4.5. Yak-52 Rear cockpit Field of View (FOV) forward (180° panoramic).** Note with FSP in place forward visibility is reduced, hangar in front obscured and side view obscured by straight wings; the remainder of forward FOV is unaffected.

1.4.109. One purpose of the PIC, as Safety Pilot, was the mitigation of the risk posed by potential emergencies. Reduced rear cockpit visibility is not abnormal in tandem aircraft. Reduced cockpit visibility does not present an issue unless it precludes the pilot from completing a task. In this case the task that the PIC reported that he planned to delegate was a key part of emergency handling. The PIC's plan was not relayed to supervisors; therefore, the risk that it posed was not identified or assessed.

1.4.110. The Panel considered the wisdom of handover of control of an aircraft in the latter stages of a FL. Selection of a suitable landing surface should result in an object free landing area. In the latter stages of a FL the ability to roll the aircraft to miss objects is limited by height and energy. The successful completion of the FL is dependent on a wings level, controlled landing with stopping distance being dictated by relative wind, aircraft performance and surface. Handing over of control leads to a short period of time while the receiving pilot gets used to trim loads and control feel, and also introduces the possibility of a failed handover resulting in no one at the controls.

1.4.111. The front cockpit in the Yak-52 had better forward visibility than the rear cockpit (Figures 1.4.4 and 1.4.5); however, a curved, out of balance or offset approach can partially mitigate this. The better visibility from the front cockpit may allow a better assessment of height immediately before touch down; however, an operator may obtain this information from other cues whilst occupying the rear cockpit. The PIC was the only person in the aircraft throughout QE with experience of landing the Yak. All other participants had no experience of the Yak-52 'landing picture' or the control feel in a descending, deceleration to touch down. Control handover to the unqualified control recipient, who had little or no familiarity of the Yak's handling characteristics, in an unfamiliar environment at a critical point in the flight would introduce additional risk.

1.4.112. The plan to delegate landing to an unqualified pilot in a Forced Landing made an unsuccessful outcome more likely and in the opinion of the Panel was a **Contributory Factor**.

1.4.113. The PIC's omission of a brief, on both the restricted rear cockpit visibility and his emergency handling plans, to an ETPS supervisor led to a risk going unidentified and mitigation not being in place. This was an **Other Factor**.

**The Selection of the Pilot in Command for Safety Pilot Duties**

1.4.114. The PIC's logbook shows that at the point of his first period at MOD Boscombe Down, he had a total of 176:40 Yak-52 hrs. The PIC flew his first QE sortie as PIC on 5 Jul 10. His logbook records his first flight as a FI in the Yak-52 as 21 Aug 11. The PIC logged no Yak-52 FI time prior to his first QE flight. There were 4 Yak-52 sorties recorded in the PIC's logbook prior to his first QE which identified the presence of another pilot. These took place after the PIC had qualified as a FI, but the logbook did not include entries for FI time for these sorties whereas for other sorties on other aircraft types it did. The first ETPS supervisor that flew with the PIC in 2010 did not formally assess the PIC's suitability for the Safety Pilot role or his competence. A familiarisation sortie was conducted prior to each QE with one being flown on 4 Jul 16 with the exercise tutor who was not himself a flying supervisor. During the familiarisation sorties it was demonstrated to the safety pilot the types of manoeuvres and sortie profile that were anticipated during a QE. Following the familiarisation sortie on 4 Jul 16 the PIC e-mailed the aircraft owner to say that he did not think that the 2016 ETPS course had any aerobatic competent students, so the week would involve only gentle flying. The profile for all QE sorties included both spinning and aerobatics.

Exhibit 86

Exhibit 93  
Witness 1

Witness 33  
Exhibit 76

1.4.115. The PIC reported that his logbook, which lacked logged Yak-52 FI flying time, was not checked by anyone at MOD Boscombe Down prior to his first QE. This was pertinent as a pilot with no rear seat experience was unlikely to be able to carry out the Safety Pilot duty. The failure to check the PIC's logbook indicated a lack of rigour being applied to the selection of the PIC in 2010, and since, because his ability to act as Safety Pilot had not been assured. The Panel was told by multiple witnesses that a reason for the low level of both assurance and review of the PIC's activity was due to significant historical assurance work. There was no evidence of significant historical assurance work except for the PIC's first familiarisation sortie flown with a ETPS tutor, which was itself not a formal assessment. The Panel was unable to determine how the PIC arrived at the conclusion that 2016 QE flying would all be gentle or why he told the owner that there were no aerobatic competent students; however, the e-mail was in the context of care of the aircraft rather than conduct of activity.

Exhibit 148

Witness 21  
Witness 33  
Witness 20

**Definition of Safety Pilot Duties**

1.4.116. The Framework Agreement and PO are 2 possible places to capture the requirements of the PIC; however, the documents are written at a high level for contracting purposes. The exercise phase tutor identified that ETPS had made it clear to the PIC about the heights to be used for aerobatics, the sortie lengths, who was to sit in which cockpit and the times of take-off and landing.

Witness 1

1.4.117. As the only contractual documents that existed between CPT Ltd and QinetiQ, for Yak QE, were the Framework Agreement and the PO, the duties of the PIC should have been captured in one of them. It would be reasonable to expect a pilot who was being remunerated for the service of acting as PIC, to be assessed for suitability to the task. This could take the form of a sortie with the specific aim of assessing competence; indeed, the Chief Test Pilot expected that the exercise tutor to have assessed the PIC's competence on the familiarisation sortie. CO ETPS requested an assessment of an aircraft commander's

Witness 21  
Exhibit 149



ability to act as Safety Pilot on another aircraft type, as discussed in paragraph 1.4.260. An assessment sortie may include forming an opinion on the PIC's ability to manage a QE sortie, including emergency handling. This need not be flown by a Qualified Flying Instructor, as it need not be a check or a test; however, this assessment could be a contractual obligation on the PIC, as could adherence to FOB and MRP. The familiarisation sortie demonstrated the QE task to the PIC. The ability to handle an emergency, including the ability to fly a Forced Landing pattern to its logical conclusion, was assumed of all qualified pilots; however, there was no CAA/EASA mandated currency requirement for practice of emergencies. Competence will be affected by ability, currency, and training; therefore, competence should be assessed locally prior to exercise commencement. In comparison, the Bustard Flying Club, the civilian flying club resident at MOD Boscombe Down, insisted on qualified and current pilots completing a skills test prior to being allowed to rent certain aircraft.

Exhibit 94

1.4.118. The PIC's competence as a Safety Pilot throughout the entirety of QE was never formally assessed; therefore, the assumption that he provided a mitigation of risk was unproven, invalid and was an **Other Factor**.

1.4.119. **Recommendations.** In order to ensure that QE risks are mitigated CO ETPS should:

- a. Identify the QE risks to be mitigated by the Safety Pilot.
- b. Define the duties of the Safety Pilot.
- c. Put in place robust measures to provide assurance of a PIC's ability to mitigate the risks through performing the duty of the Safety Pilot.

### **Accident Crew Fatigue**

1.4.120. The PIC left ETPS on 7 Jul at approximately 1700 hr and was picked up from [REDACTED] at approximately 0815 hr on 8 Jul. The FSP left work at approximately 1845 hr on 7 Jul arriving home at approximately 1930 hr. He was in bed by 2300 hr and remained there until after 0700 hr, leaving for ETPS between 0730 hr and 0745 hr.

Witness 1

Exhibit 95

1.4.121. The PIC had approximately 15 hr 15 min between leaving Boscombe Down and being picked up. The FSP had approximately 13 hr between leaving work and arriving again the following morning. The PIC's activities that filled this period are known and would not have been the cause of fatigue. The FSP was adequately rested in accordance with orders. The PIC was not regulated by crew rest orders but would have been compliant in any case.

1.4.122. Both accident crew had adequate time away from work and available for sleep; therefore, fatigue was **Not a Factor**.

### **ACCIDENT SORTIE PREPARATION**

#### **The Front Seat Pilot's Preparation and Planning for the Sortie**

1.4.123 The FSP did not attend the mass Safety and Technical Brief given to ETPS students. This was offered to tutors via e-mail, by the FW tutor on 4 Jul 16 prior to the Yak-52 QE. The invitation for tutors to attend the brief described it to be essential. The brief was due to last 1 hr 30 min. The ETPS Flying Programme (Fly Pro) that was distributed on 7 Jul 16 at 1517 hr showed a staff QE sortie programmed from 1125 hr to 1220 hr, with a suggested briefing time of 1020 hr and a walk time of 1055 hr. The FSP volunteered for the flight after the first Fly Pro was distributed. The ETPS Meteorological (Met) brief usually

Witness 1

Exhibit 96

Exhibit 97

Witness 7



ended by 0915 hr. When the FSP volunteered for the sortie the Fly Pro showed 1 hr 5 min between the end of Met brief and sortie brief. The Fly Pro was subsequently amended to reflect the FSP being allocated to the accident sortie. This iteration of the Fly Pro, moved the accident sortie to a 1055 hr take off with a suggested briefing time of 0950 hr and a walk time of 1025 hr. The Fly Pro was not amended further and was still in place at the time of the accident. The re-issued Fly Pro allowed a period of 35 min post-Met Brief prior to a 35 min sortie brief. G-YAKB was only programmed for a single QE sortie prior to departing BDN. The Panel was not made aware of any time constraint affecting the originally planned 1125 hr sortie. The FSP:

Exhibit 98

Exhibit 99

a. Worked at home the night before the accident prior to going to bed. The FSP used his QinetiQ profile for work purposes, accessing the Company server via laptop and iPad. The Panel interrogated the QinetiQ server and devices. The FSP accessed and manipulated documents relevant to other primary and secondary duties; he did not access the provided QE briefing material or conduct wider research into the Yak-52 through the QinetiQ server.

Exhibit 95  
Exhibit 100

b. Left home slightly earlier than normal, at approximately 0745 hr, on 8 Jul 16, having said that he was flying and had a brief.

Exhibit 95

1.4.124. The personal effects and flying clothing of the FSP contained no evidence of sortie preparation.

Exhibit 101

1.4.125. Based on their respective departure times from [REDACTED] and home, the crew would have arrived at ETPS around 0830 hr. G-YAKB remained in the hangar until after the Met Brief when it was pushed out and fuelled by the accident crew assisted by others. No witness saw either of the accident crew at the aircraft before they arrived for the accident sortie itself. The PIC had informed witnesses that he considered the walk to and from the aircraft onerous. From the ETPS front door to the aircraft's position in the hangar is approximately 400m. At approximately 0845 hr the FW Flt Cdr talked to the FSP and confirmed that he was content to fly in the QE sortie. At approximately the same time the ETPS Duty Supervisor spoke to the FSP who had moved the QE sortie to an earlier take off time. The ETPS Supervisor subsequently saw the FSP talk to the PIC in the ETPS planning room and heard them talk about the fact that they now planned to fly together. At 0852 hr the PIC sent an e-mail to the aircraft owner concerning the planned return flight.

Witness 9

Witness 1  
Witness 5

Witness 7

Witness 8  
Exhibit 102

1.4.126. The accident crew were probably both at ETPS for approximately 30 min prior to the Met Brief at 0900 hr. The accident crew discussing the fact that they were now due to fly together probably indicated that there had been no previous dialogue between the 2 of them. It also indicated that the FSP had not been to the hangar with the PIC beforehand. It was possible that the PIC walked to G-YAKB in Hangar 626 prior to the Met Brief, either in the period before meeting the FSP or between this time and the Met Brief, in order to carry out a daily inspection. It was unlikely that the PIC would have been able to enter the hangar, complete any maintenance or inspection and egress without being seen. The PIC had also informed others that he considered the walk to the hangar and back onerous. It was most likely that neither of the accident crew went to the aircraft prior to walking for the sortie. It was unlikely that the PIC would have emailed the aircraft owner from a brief or whilst planning or preparing a sortie with another crew member. The sending of an e-mail by the PIC could have indicated that any crew preparation that took place was complete. The crew would have required 2 min to walk to the Met Brief on the north side of the ETPS building at 0900 hr. This may have been used to discuss the sortie.

1.4.127. The ETPS Duty Supervisor reported that the crew went to the Met Brief. The FSP was subsequently seen in ETPS Operations at approximately 0915 hr. The accident crew arrived at the Authoriser’s Desk for out-brief at approximately 0930 hr<sup>50</sup>.

Witness 8

1.4.128. The ETPS programme, including the Safety and Technical Brief originally scheduled a total of 2 hr 5 min for sortie preparation and briefing for a person who had not flown the Yak-52 before, plus a further 1 hr 5 min post Met Brief that could have been used for preparation and planning. Table 1.4.1 summarises the accident crew’s time management as compared to the original schedule.

Time Available	Original Schedule	Amended Fly Pro	As Executed
ETPS Safety and Technical Brief	1 hr 30 min	-	-
Brief	35 min	35 min	15 min
Preparation and planning post Met Brief	1 hr 5 min	35 min	0 min

Exhibit 103

Exhibits 97 and 99

**Table 1.4.1 – G-YAKB Crew Time Management**

1.4.129. The Panel viewed the original schedule as being reasonable, noting that an ETPS tutor considered the 1 hr 30 min Safety and Technical Brief to be essential. As the FSP had missed the Safety and Technical Brief, the contents needed to be covered before the sortie. Due to the FSP’s experience and because the brief would have been conducted on a one-to-one basis, this may not have taken 1 hr 30 mins. The original schedule allowed 1 hr 5 min for the FSP to prepare independently for the sortie, if he chose to do so. This could have included private study to make up for having missed the Safety and Technical Brief. The amended Fly Pro allowed a reduced amount of time of 35 min between Met Brief and sortie brief; however, the accident crew briefed immediately post Met Brief, so the opportunity for individual preparation was not taken. The sortie brief of 35 min may have been appropriate for someone who had attended the 1 hr 30 min safety brief; however, having missed it, for the FSP the accident sortie brief would have had to have been a type, technical, safety, emergency and sortie brief, including a review of the FTS and addendum. In a tandem aircraft without a full suite of controls in both cockpits, the brief also needed to cover cockpit differences, communications and the roles and responsibilities of both pilots in normal operations and in emergencies. The accident crew spent approximately 15 min briefing when 2 hr 5 min had been allocated for this task. It was not possible for the accident crew to cover all of the appropriate briefing material in an eighth of the allocated briefing time. The Panel has been unable to determine why the accident crew followed this timeline, in the absence of time constraints on the crew.

Exhibit 96

Exhibit 97

Exhibit 99  
Witness 8

**Qualitative Evaluation Sortie Emergency Briefs**

1.4.130. The Panel was presented with conflicting evidence as to what emergency handling instructions or considerations QE sortie briefs actually contained. Interviewees that led the brief reported that they followed the ETPS briefing guide diligently; others reported that when the PIC led, the brief<sup>51</sup> it was short. The emergency brief was reported to be a simple statement from the PIC that he would deal with all emergencies. Some TPS QE participants stated that it was their understanding that they would continue to fly the aircraft initially in an

Witness 2  
Witness 34  
Witness 3  
Witness 6

<sup>50</sup> Assessed as being 0930 by a different crew who out-briefed at the same time; prior to 0935 by a pilot who subsequently passed the accident crew as they walked across the airfield to the hangar; at approximately 0945 by the Duty Supervisor.

<sup>51</sup> The student is required to lead the brief. The Panel was unable to determine why this was not always the case.

emergency if they were at the controls<sup>52</sup>. The Panel received testimony from a multi-type fast jet Qualified Flying Instructor who took part in the Yak-52 QE. The witness reported that despite attendance at the Safety and Technical Briefs, a cockpit familiarisation, private study and sortie brief, that he still had safety-related questions for the PIC when at the aircraft.

1.4.131. Given the common recollection of all witnesses other than the PIC, the Panel considered it most likely that the standard emergency brief for QE sorties was a simple 'catch all' that the PIC would deal with any emergency but that the FSP could continue to fly the aircraft initially if he was doing so when the emergency arose. The Panel was unable to confirm the contents of the accident crew's emergency brief; however, given that the contents of the type, sortie, FTS and addendum, safety and emergency briefs were conducted in approximately 15 min it is probable that the brief followed the established pattern of previous emergency briefs and was limited to the PIC stating that he would deal with all emergencies. In the absence of a thorough emergency brief a crew member operating in an unfamiliar aircraft type would be less likely to possess the necessary knowledge to assist in fault diagnosis or perform specific emergency drills, or other actions, autonomously, punctually and correctly. The ETPS Emergency of the Day, which should have been briefed, was an Immediate Engine Relight. Whilst this terminology is usually associated with Fast Jet types this would have provided the accident crew with an opportunity to discuss immediate actions and responsibilities in the event of an engine failure.

Exhibit 99

1.4.132. Despite adequate time to plan and prepare for a Yak-52 sortie being available the opportunity was not taken. As a result the crew's preparation was inadequate and probably omitted a thorough safety brief, with the result that the FSP was unable to contribute meaningfully to fault diagnosis or emergency handling. The Panel concluded that inadequate time spent in preparation, planning and briefing was a **Contributory Factor**.

1.4.133. **Recommendations.** CO ETPS should ensure that:

- a. Both staff and students, operating a new aircraft type, receive the information necessary to operate the aircraft safely, specifically highlighting any role that they may be required to perform in an emergency, in order to adequately prepare them for flight.
- b. The PIC gives a thorough emergency and safety brief prior to any QE sortie, which includes the responsibilities of all crew members throughout an emergency and any aircraft peculiarities that may affect them, in order to adequately prepare them for flight.

#### Aviation Task Risk Matrix

1.4.134. The accident crew filled out an ETPS Aviation Task Risk Matrix (ATRM). This is a local form which ascribes supervisory risk scores to facets of the sortie using a scale of 0, 1 or 2, zero indicating no risk. Individual scores are added together to provide a total score for the sortie. The crew calculated a total score of 2. This classified the sortie as routine<sup>53</sup>. The Panel retrospectively calculated a score of 12 which would have classified the sortie as 'Duty Tutor Approval'; however there were two individual scores that would have further elevated this to 'Exec Approval'<sup>54</sup>. ETPS supervisors could not actually approve the civilian sortie. The ATRM form for the QE familiarisation sortie flown earlier in the week was filled in erroneously. Upon arrival at ETPS the PIC's hours failed to meet any of the published

Exhibit 87

Exhibit 104

<sup>52</sup> One TPS stated that his understanding was that he would fly the aircraft initially in an emergency but he went on to state that the PIC had told him that, in the event of an Engine Failure After Take Off, the PIC would take control immediately.

<sup>53</sup> 0-7 is considered routine.

<sup>54</sup> The nominated 'Execs' are the CO, Executive Officer, Flight Commanders and the Chief Flying Instructor.



criteria and should have scored a 2. They were scored as 0. ATRM forms filled out earlier in the week were signed off by supervisors despite inconsistencies. For example, the form has a separate line for 'Crew Member Unqualified on Type' and 'Other pilots [sic] hours on type'. In some cases pilots with no hours on type scored a 1 for being unqualified but not for having zero hours on type.

1.4.135. Use of the ATRM for operations involving civilian operated COCR was a useful assurance practice, as it assisted ETPS supervisors to identify sortie content which could benefit from greater scrutiny. Whilst a civilian PIC could not be compelled from a legal or regulatory standpoint to use the ATRM tool, the ETPS out-brief required it to be completed and the QE FTS directed ETPS personnel to follow local procedures. By completing the ATRM the accident crew indicated that they were cognisant of the requirement. If the form was filled out inaccurately it could have had a negative effect as it provided false assurance of the supervisory risk. On examination of the form the Panel considered whether the risks had all been adequately captured and scored. The form should have captured the following:

Category	Actual Score	Panel's Score	Justification for deltas
Personal Concerns	0	2	Panel aware of a concern qualifying as "Major". Major is scored as 2.
Mission Complexity	1	2	Mission was "QE". QE is scored as 2.
Briefing time	0	2	Crew took 15 min for type, safety, emergency and sortie brief. The brief was "Compressed". Compressed Brief is scored as 2.
Area Weather	0	1	Prevailing conditions were "Limited VMC". Limited VMC is scored as 1 <sup>55</sup> .
Impact of tech issues	0	2	"2 or more" technical issues existed. 2 or more is scored as 2. Various instruments in each cockpit u/s including RPM gauges. <sup>56</sup>
Crew member unqualified on type	1	1	"Yes" is scored as 1.
Other pilots on type hours	0	1	"<50 hrs" Less than 50 hrs is scored as 1. FSP had less than 50 hours Yak-52.
Aircraft Commander hours	0	1	"≤30 hrs in 90 days" Less than 30 hrs in the last 90 days in isolation is scored 1. Aircraft Commander had less than 30 hours in last 90 days
Total	2	12	Duty Tutor Authorisation
Highest factor	1	2	Exec approval required

**Table 1.4.2. ATRM Risk Factor Score Comparison**

1.4.136. Multiple entries into the ATRM were inaccurate. This may have indicated a lack of care in filling out the ATRM, a misunderstanding of terminology, the dismissal of the form's importance or a deliberate attempt to disguise supervisory risk. Notwithstanding that it was the FSP's responsibility to fill out the ATRM, there should have been collective awareness (amongst aircrew and supervisors) that some of the entries were incorrect, for example in

<sup>55</sup> Limited VMC is not a recognised definition. The Panel considers launch in Colour code GRN with IFR diversions in a VFR only aircraft as 'Limited VMC'.

<sup>56</sup> The Panel considers the RPM gauge malfunction to have warranted immediate sortie cancellation rather than elevated risk.

## OFFICIAL SENSITIVE

the case of both weather and sortie complexity. Had the aircraft serviceability been reported and the PIC's logbook checked, other inaccurate entries would also have been identified. As the aircraft serviceability had not been reported and the PIC's logbook not checked, opportunities were missed to identify supervisory risk. It is possible that had the ATRM adequately reflected sortie supervisory risk then an ETPS supervisor may have delayed or cancelled the accident sortie or subjected the sortie and sortie plan to greater scrutiny. That being said, the inconsistency of approved ATRMs from Yak-52 QE week indicated that supervisors themselves were not being rigorous in their use of the document. Whilst the use of a Risk Matrix may be a valid mechanism to assess supervisory risk, the ETPS ATRM taxonomy lacked coherence, for example '*Flying 3 sorties in a day*' (of undetermined sortie length and content) attracted the same score as '*Death in the family*'.

1.4.137. Misuse of the ATRM which masked supervisory risk was an **Other Factor**.

1.4.138. **Recommendation.** In order for the ATRM to be used effectively as a supervisory tool, CO ETPS should:

- a. Review the utility of the Matrix.
- b. Ensure that all ETPS supervisors and students receive periodic training on the correct use of the Matrix.

### Authorisation

1.4.139. The accident crew out-briefed at ETPS and entered the sortie into the ETPS Authorisation Sheet as 'Info Only'. There was no ANO requirement to authorise a sortie. It was an order written in the QE FTS that QE sorties follow the normal operational process.

Exhibit 46

1.4.140. The lack of an authorisation sheet signed by the PIC acknowledging his duties as Aircraft Commander was correct and was **Not a Factor**.

## ACCIDENT SORTIE

### Accident Sortie Timeline Post-Brief

1.4.141. There was no video or electronic evidence that identified exactly when the accident crew out-briefed and walked for the sortie. Based on the evidence of witnesses the Panel has been able to determine that the accident crew out-briefed at approximately 0930 hr; walked across the Aircraft Servicing Pan (ASP) at approximately 0935 hr and were in the line office at approximately 0940 hr.

### Time Management

1.4.142. The Panel considered whether or not the accident crew were rushed. In considering the question the Panel noted that:

- a. The PIC had rushed briefs during the week, with no explanation being given as to why he was doing so.
- b. The PIC had emailed the owner on 7 Jul 16 to relay concerns about a planned return trip to Kemble, which would have been geographically close to and time conflicted with a Royal Flight. In a second e-mail sent at 0852 hr on 8 Jul 16 the PIC suggested that an earlier departure was now possible; therefore, the potential conflict with the Royal Flight no longer existed.
- c. The FSP moved the sortie on the Fly Pro from its original take off time of 1125 hr

Witness 3  
Witness 6

Exhibit 105

Exhibit 102

Witness 8



<p>to 1055 hr. The FSP subsequently submitted a Flight Notification Form<sup>57</sup> requesting a 1000 hr take off.</p>	Exhibit 86
<p>d. The Fly Pro displayed in the ETPS Operations Room at the time of the accident showed that the middle sortie of the day had been cancelled and an arrow indicated that the PIC's return to Kemble would occur earlier than planned, well before the Royal Flight presented an issue.</p>	Exhibit 99
<p>e. A witness reported that the crew appeared rushed on arriving in the hangar.</p>	Witness 9
<p>1.4.143. There was no operational imperative to complete the sortie and the Panel could not identify any time constraint on the accident crew. The accident crew, in bringing the sortie forward twice, briefing in a compressed period and appearing rushed at the hangar exhibited behaviours that indicate they were acting under a time constraint. In doing this the accident crew denied themselves sufficient time to conduct thorough preparation for flight. In paragraph 1.4.174 the Panel considered the actions of the FSP during the accident sortie and whether he exhibited behaviours that indicated that he was not fully aware of his role in the handling of the emergency, what his actions should be or what the implications of his actions were.</p>	
<p><b>Fuel and Oil Replenishment</b></p>	
<p>1.4.144. The PIC had relied upon QinetiQ personnel to fuel and oil the aircraft throughout the QE week. These QinetiQ personnel had sourced the oil from QinetiQ stores. The replenishing of the oil by QinetiQ personnel was not always supervised by the PIC. QinetiQ personnel had received verbal instruction on how to replenish the oil from the PIC in previous years. The QinetiQ employees were given no further Yak-52 specific handling instructions. CPT Ltd was contractually responsible for the supply of oil<sup>58</sup>; however, local arrangements had been made in 2010 whereby QinetiQ provided the oil. This practice endured despite being contractually incorrect. On the morning of 8 Jul 16 no QinetiQ employee or the PIC checked or replenished the oil. Prior to the accident sortie the PIC removed the fuel filler caps and re-fitted them following the refuel. Generic Risk Assessments had been produced by QinetiQ that covered risk to their employees on the ASP and through interaction with aircraft.</p>	Witness 35
<p>1.4.145. In executing the task of replenishing critical and (in the case of the fuel) flammable fluids with sub-optimal supervision and training, the well intentioned personnel were exposing themselves to risk that was contractually unnecessary. The limited training and supervision of QinetiQ personnel tasked with assisting the PIC extended to their role as 'first response' fire fighter and see-off crew/marshaller. Whilst some hazards are generic to aircraft handling, such as propeller hazards, aircraft-specific information is still required to perform all expected tasks safely, eg the best point of entry to engine cowling for fire suppression.</p>	Witness 29
<p>1.4.146. The limited training provided to QinetiQ personnel, and their supervision by the PIC, resulted in additional un-assessed risk which was an <b>Other Factor</b>.</p>	Exhibit 2 Witness 35 Witness 9 Exhibit 106
<p>1.4.147. <b>Recommendation.</b> QinetiQ should review support, including associated processes necessary to deliver it, to third party aircraft operators to ensure relevant risks are captured and personnel are suitably trained.</p>	

<sup>57</sup> Colloquially referred to as a "Warn Out" form.

<sup>58</sup> The sub-sub-contract to the PIC is insufficiently clear to be certain whether this responsibility was passed from CPT Ltd to the PIC.



**Aircraft External Checks**

1.4.148. There was no mandated set of external checks for the Yak-52. Guidance translated from Russian is contained within the Aerostar Yak-52 Flight Manual. Throughout the week 4-8 Jul the PIC was not seen conducting maintenance on the aircraft. Aircraft pre-flight external checks are referred to as 'walk rounds'. Three QinetiQ maintenance personnel report that the PIC did not conduct walk rounds. Whilst the witnesses were not categorical about what the PIC had checked, 4 ETPS students reported that the PIC conducted a walk round of the aircraft. One ETPS student reported that he did not, and 3 ETPS personnel did not recall witnessing a walk round. The PIC stated that he always completed walk rounds.

Exhibit 82  
Witness 35  
Witness 28  
Witness 29  
Witness 9  
Witness 2  
Witness 3  
Witness 6  
Witness 36  
Witness 4  
Exhibit 145

1.4.149. The Panel considered the conflicting evidence available to them. The omission of the walk round noted by maintenance personnel detached from in-cockpit activity and consequently able to witness multiple events, is probably a more reliable indicator than the testimony of the aircrew who conducted a single evolution and may have been task saturated at the time. The External Check is a procedure prescribed in the Aerostar Yak-52 Flight Manual. An external check is common practice across aviation as it allows aircrew to notice unserviceabilities pre-flight and is an important check of an aircraft's readiness for flight. 'Walk Round' is a colloquial simplification. Walking around an aircraft does not in itself offer any assurance of readiness for flight and is unlikely to result in potential issues being identified. External checks may have occurred whilst students were pre-occupied with strapping into an unfamiliar aircraft; however, the PIC assisted students with the strapping in itself, which would rule out concurrent activity taking place. The walk round as prescribed by Aerostar contains visually significant and memorable checks such as pulling through<sup>59</sup> the engine<sup>60</sup>, checking the underside of the fuselage for leaks and checking that control surfaces move. The PIC reported that he would always pull through the engine albeit that if he was familiar with the individual airframe, this might only be before the first flight of the day. It was unlikely that maintenance personnel would report the omission of a properly conducted walk round to the Panel had one taken place. Omission of pre-flight checks would mean that even had symptoms of an impending failure been present they would probably not have been noted.

Exhibit 150

1.4.150. On balance of evidence the Panel opined that the PIC probably omitted a thorough external check of G-YAKB before the accident sortie. This probable omission removed an important opportunity to notice indications of the impending engine malfunction; however, the Panel was unable to conclude that any such indication existed. This omission was therefore an **Other Factor**.

1.4.151. The PIC's omission of external checks during QE was noticed by QinetiQ employees but not reported.

Witness 9  
Witness 28  
Witness 29

1.4.152. The omission of checks should have been reported to QinetiQ supervisors and passed to ETPS. Without the feedback that the PIC was not conducting walk rounds ETPS supervisors were denied an opportunity to query the PIC's conduct, suggest a change to that conduct, or to brief more widely to guard against such conduct.

<sup>59</sup> The external check of a radial engine aircraft includes, when the engine is cold, 'pulling through' which is achieved by manually turning the propeller. This redistributes oil that may have pooled in the lower cylinders which, if left in situ, can lead to the affected cylinders becoming hydraulically locked in place and the con rods that attach them to the engine shaft being bent on start. No interviewed ETPS student or QinetiQ employee witnessed the PIC turn the propeller.

<sup>60</sup> Although this would only be performed for the first flight of the day or if the engine had cooled between flights.

1.4.153. The lack of communication between QinetiQ maintenance personnel and ETPS removed an opportunity for supervisors to review the conduct of QE, which was an **Other Factor**.

**Sortie Profile**

1.4.154. G-YAKB was cleared to take off at 1015:20 hr and following a VFR departure to the west of BDN contacted Boscombe Approach<sup>61</sup> at 1019:01 hr requesting a Traffic Service. G-YAKB climbed to 5200 ft, achieving this altitude at 1022 hr. G-YAKB then conducted General Handling (GH) between 3400 ft and 5200 ft amsl. At 1029:50 hr G-YAKB's entered a descent from 5200 ft amsl to 3700 ft amsl. G-YAKB levelled at 3700ft amsl heading in a westerly direction before turning onto a southerly heading. The crew issued a Mayday call at 1030:29 hr once steady on the southerly heading, 12.5 nm west of BDN. The Mayday call included a request for a radar bearing to BDN. The PIC reported that this was following the air exercise and after the decision had been made to return to BDN.

Exhibit 18  
Exhibit 21  
Exhibit 19

Exhibit 21

Witness 11

**Reliability of the PIC's Recollection**

1.4.155. The Panel considered whether it was reasonable to rely on the PIC's recollection of events due to inconsistencies when reviewed against the available evidence. The hospital treatment received by the PIC following the injuries he sustained during the crash meant that his witness statement was not taken until 30 Sep 16.

Witness 11

1.4.156. The length of time that elapsed between the accident and the PIC providing his witness statement may have caused some inconsistency in his recollection; equally there may have been medical reasons for it. The PIC's statement regarding the recovery provides examples of the inconsistencies:

- a. The accident crew completed the ETPS Flight Notification Form with their intentions to complete a one hour sortie and to be back in the BDN visual circuit 50 min after launch. This would correspond to a cessation of GH approximately 40 min into the sortie. G-YAKB had launched 15 min later than the stated departure time. The aircraft had been airborne for approximately 14 min 30 sec and conducted GH for approximately 8 min when GH ceased. The PIC reported that GH was complete and the accident crew were commencing the Berwick VFR recovery.
- b. If the crew were commencing the Berwick recovery they should have been heading east instead of west. The gyro compasses were known to be un-serviceable, which may have misled or confused the crew by giving a false heading indication. Alternatively, due to the large volumes of cloud the crew may have been unable to visually fix their position. The inclusion of a request for a heading to the airfield in the Mayday call may indicate that the crew were disorientated. The evidence suggests that the crew were not commencing the Berwick recovery at the time of the Mayday call. A possible explanation was that the crew had decided to commence recovery but had yet to actually direct the aircraft towards BDN.
- c. The crew had planned for a one hr sortie yet, if the PIC's recollection is correct, they were commencing recovery just 15 min after take-off. The Panel was unable to determine the reason for the early recovery; however, it does not match the original plan for the sortie.

<sup>61</sup> This would usually occur at the village of Berwick St James, approximately 5 nm to the west of Boscombe Down.

1.4.157. The Panel received advice from RAFCAM that the PIC sustained [REDACTED] injuries during the impact sequence of the aircraft with the ground. Injuries of this severity, coupled with any associated [REDACTED], were likely to influence a pilot's ability to recall accurately the events surrounding an accident. It was suggested that any recollections reported by the pilot, relating to the peri-accident events, should be treated with caution and may not be relied on fully, as his recollections may be affected by his traumatic injuries.

Exhibit 107

1.4.158. The Panel was unable to fully rely upon the PIC's recollection of events. This meant that the Panel had no reliable account of the accident sortie from a participant.

**Engine Malfunction**

1.4.159. The PIC reported that the engine stopped with the propeller wind-milling and no residual thrust. The PIC observed the fuel pressure gauge indicating zero. The PIC diagnosed engine driven fuel pump failure. The FSP reported by a Radio Telephony (R/T) that the aircraft had suffered a "Major Major Malfunction" with no further amplification<sup>62</sup>.

Witness 11

Exhibit 21

1.4.160. It was not known what time had elapsed between the loss of thrust and the PIC observing the fuel pressure at zero. The FSP's R/T indicated that the crew had not concluded a diagnosis of the malfunction at transmission or that the PIC had diagnosed the problem but not informed the FSP. It was unlikely that the FSP would have used a general term for the emergency if he was aware of the exact nature of the malfunction. The FSP's use of "Major Major" to describe the malfunction was coherent with the PIC's description of the malfunction.

Witness 11

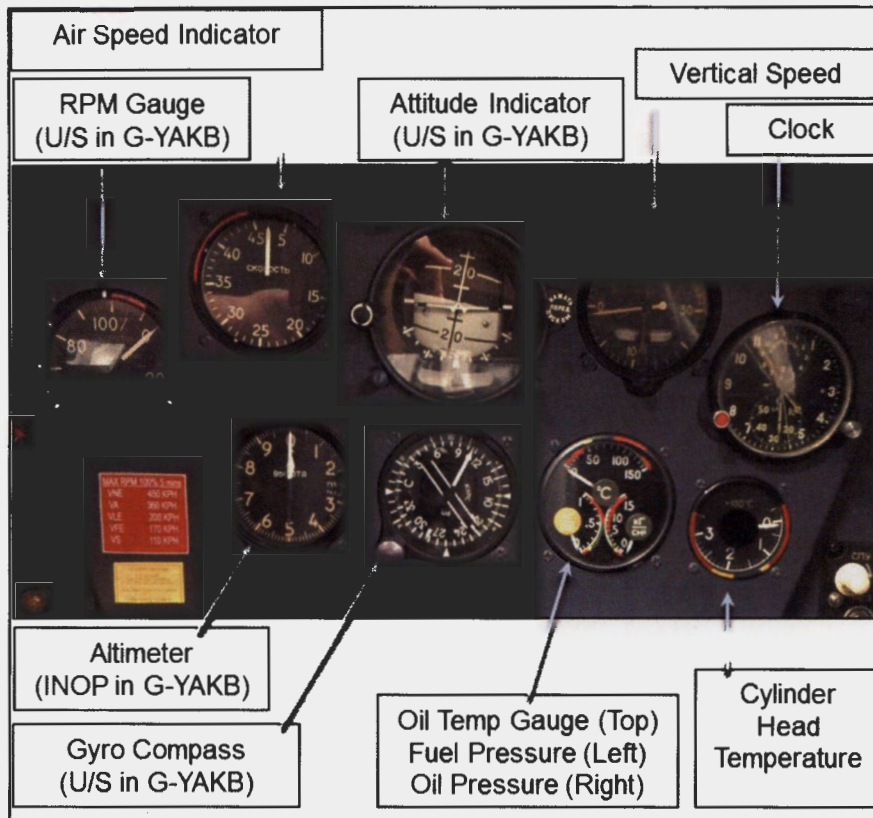

Figure 1.4.6 Yak-52 Rear Seat Cockpit Instrument Panel similar to that in G-YAKB.

<sup>62</sup> For example 'mechanical failure' or 'fuel pump failure'.



1.4.161. It was most likely that the aircraft suffered a loss of thrust but the crew could not explain or agree upon the failure mode at the point of the Mayday call or the PIC had not communicated his diagnosis to the FSP.

1.4.162. Fuel pressure was displayed on a triple gauge in the Yak-52, which also showed oil temperature and pressure (See Fig 1.4.4). The PIC observed a loss of fuel pressure and diagnosed an engine driven fuel pump failure.

1.4.163. With no Cockpit Voice Recorder (CVR) available the Panel cannot determine what intra-crew communications were made. The PIC's statement contained no mention of what the FSP's instruments indicated. With no FDR available to the Panel it is impossible to state exactly what symptoms the PIC observed or to be sure what both sets of cockpit instrumentation were indicating at the time. There is a possibility that the PIC witnessed an indication other than fuel pressure dropping to zero. This could have been another indication decreasing or the fuel pressure reducing. An indicated loss of fuel pressure could have been caused by pump failure, indicator failure, sensor failure or fuel supply blockage/restriction. On the assumption that both RPM gauges were unserviceable, the only engine performance instrument that was serviceable was the MAP gauge in the front cockpit. Neither pilot had sufficient information to diagnose the cause of the emergency. The PIC had less information than the unqualified FSP who had received inadequate preparation to assist in an emergency. In this situation successful diagnosis was unlikely. Following engine malfunction the PIC observed the further individual symptom of fuel pressure reduction and incorrectly diagnosed the cause<sup>63</sup>.

1.4.164. The PIC reported taking control from the FSP to exert positive-G forces on the aircraft in order to free flapper valves that may have become stuck. The PIC reported doing so upon noting the fuel pressure reading zero. This was the last occasion that the PIC recalled handing over control.

Witness 11

1.4.165. The PIC held an honest belief that the action might serve to rectify the situation and the application of positive-G did not have a bearing on the outcome of the emergency.

#### Operation of the Fuel Primer Handle

1.4.166. The Yak-52 had a manual fuel primer handle in the front cockpit only (Figure 1.4.2). It had 3 positions, a central stowed position, a left position and a right position. (Figure 1.4.5). This allowed the FSP to pump fuel from the wing tanks to a position upstream of the Engine Driven Fuel Pump in the left position or from the wing tanks to the turbo manifold in the right position. The pump would not deliver fuel unless it was either fully left or fully right. The PIC recalled that under his direction the FSP pumped the fuel primer in the left position and each time he did this it resulted in an engine pulse, with the engine speeding up and developing thrust in sympathy with the forward stroke of the pump, before returning to a lower engine speed with no thrust. The PIC recalled that this pulse was accompanied by a short lived increase in fuel pressure. The PIC recalled being able to confirm that the FSP was pumping in the left position, ie upstream of the fuel pump. The fuel primer handle was discovered post impact to be to the left of centre in an unlocked position. In this position, the internal design of the fuel primer mechanism is intended to prevent fuel from passing through the manual pump. The PIC's head would have been approximately 2m from the FSP's hand during the emergency.

Witness 11

Exhibit 108

<sup>63</sup> AAIB investigations determined that the Engine Driven Fuel Pump was serviceable.

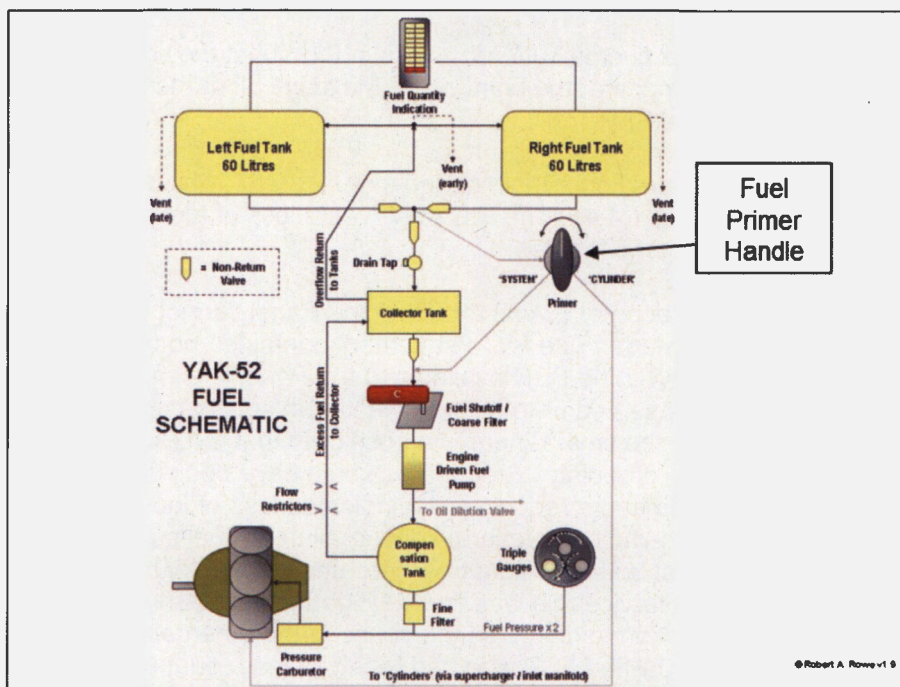

Figure 1.4.7 Yak-52 Fuel System<sup>64</sup>

1.4.167. Given the position of the fuel primer handle, the distance between it and the PIC's head and possible obscuration by cockpit coaming, and FSP's hand and shoulder; it is unlikely that the PIC could have been certain which position the FSP was pumping in. Pumping in the left position could have resulted in an increase in the reported system fuel pressure rise<sup>65</sup> and engine pulsing, pumping to the right could have resulted in the engine pulsing but without a change in the fuel pressure indication. It is unlikely that the FSP had received an in depth brief on the fuel primer handle and its operation in an emergency.

**Airborne Restarts of the M-14P**

1.4.168. The PIC recalled continuing towards BDN in anticipation that the engine would fully recover. The engine re-start drill is contained in the Aerostar Flight Manual; however, further publications such as check lists were not made available to QE participants. The throttle is required to be in, or forward of, the 1/3 open position for M-14P re-start. The Flight Manual then requires the fuel pump lever to be used in the left position to increase fuel pressure. The manual notes that subsequently "*it is advisable to pump fuel in the engine cylinders*", i.e. in the right position. The drill then requires that the throttle lever is brought to the take-off condition as soon as the engine starts running again. The PIC stated that he did not move the throttle but went on to state that he may have exercised it.

Exhibit 82

Witness 11

<sup>64</sup> Source: [http://matronics.com/wiki/images/7/7a/RR\\_YAK-52\\_Fuel\\_System\\_Schematic\\_v1p9.jpg](http://matronics.com/wiki/images/7/7a/RR_YAK-52_Fuel_System_Schematic_v1p9.jpg).

<sup>65</sup> Which the Panel was unable to confirm.

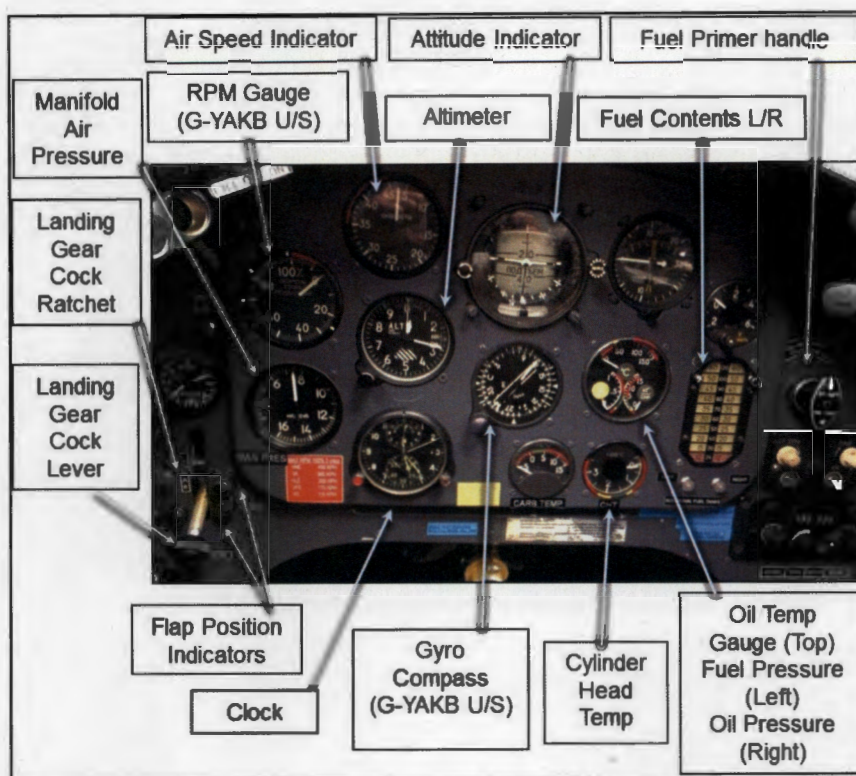

Figure 1.4.8 Yak-52 Front Seat Cockpit Instrument Panel similar to that in G-YAKB.

1.4.169. The PIC's recollection does not align with the Aerostar guidance for engine re-start. The Panel is unable to categorically state what actions the crew took. Irrespective of the crew's actions the accident crew did not restart the engine.

1.4.170. The Yak-52 Aerostar Flight Manual translation made available to the Panel by AAIB requires crews to use the fuel pump lever in the right hand position for low fuel pressure emergencies. The Panel was advised by the AAIB that this is an incorrect translation of the source document and that the fuel pump lever should be in the left position. The ETPS document set for Yak-52 QE contained extracts from a different manual that correctly described the use of the manual primer pump in normal operations but did not include any emergency handling drills or advice.

Exhibit 82

Exhibit 129

1.4.171. It was not possible for the Panel to determine whether the PIC knew the published drills. It was likely that the PIC directed the FSP to use the left hand position of the fuel pump lever, based on knowledge or experience, and when the FSP's actions produced an engine pulse the PIC settled upon this as a reasonable action. Although, the evidence showed that the FSP had not accessed the limited ETPS Yak-52 briefing material provided for QE, study of the extracts from the Yak-52 manual available in the 'Yak Pak', would not have provided the FSP with sufficient correct information to assist the PIC in emergency diagnosis and handling.

1.4.172. The incomplete ETPS Yak 52 briefing material provided for QE, which was insufficient for the FSP to prepare for the sortie, was an **Other Factor**.

1.4.173. **Recommendation.** CO ETPS should have access to aircrew publications in English for all QE types, in order to ensure crews and supervisors are adequately briefed prior to QE.



**Actions by the FSP**

1.4.174. Operation of the fuel primer handle was covered in the safety brief that the FSP did not attend. The PIC recalls that the accident crew were unable to maintain height as the FSP was not pumping fast enough; however the PIC did not ask the FSP to pump faster. The rate required to maintain level flight was approximately 1.5 pumps per second; the PIC recalls the FSP pumping at approximately 0.25 pumps per second. The Panel is unable to confirm whether this report is accurate. The published rate of descent for a Yak-52 at optimum gliding speed is 1251 fpm<sup>66</sup>. Initially G-YAKB descended at an average of approximately 300 fpm over a period of 1:45 min whilst turning and changing Ground Speed, then established a steady heading and rate of descent of 1150 fpm for 1:45 min. It is possible to operate the fuel primer handle at a rate sufficient to have allowed G-YAKB to recover to BDN from the position of the Mayday call.

Witness 1  
Witness 11

Exhibit 19

Exhibit 109

1.4.175. In the absence of a FDR the Panel is unable to determine the crew's actions or the effect of the individual actions. The Panel is unable to determine for how long the FSP pumped, at what cadence or the total number of pumps he made. Furthermore the Panel was unable to be certain what affect operation of the pump had on aircraft performance. It is however, implausible that the accident crew would reduce their rate of descent to 300 fpm using the fuel primer, which if continued would have allowed a recovery to BDN, and then stop pumping. Therefore the 300 fpm rate of descent is most likely to have been due to aircraft handling<sup>67</sup> and may have included pump operation. The Panel's opinion was that the FSP was unlikely to have maintained a deliberately slow cadence whilst pumping if he was aware that his pumping was being relied upon to maintain level flight. It would have been obvious that the aircraft's rate of descent was significant. The PIC's omission of an instruction to increase the pump rate is illogical; however, this may indicate an incomplete and incorrect recollection of events. The FSP's only experience of using the fuel primer handle was during engine start, when a fast cadence was not required.

1.4.176. The Panel was unable to conclude whether the PIC's recollection of the FSP's pumping cadence was accurate or what the FSP's actions actually were.

**Intention to Forced Land**

1.4.177. The Mayday call was made approximately 13.2 nm west of BDN. The final radar fix was approximately 9 nm west of BDN. Surface wind at BDN was 230 degrees True at 14 knots. From the point of the Mayday call at 1030:29 hr to the last radar fix at 1033:34 hr the aircraft descended downwind from 3800 ft amsl, having climbed 100 ft whilst manoeuvring, to 1475 ft amsl in 3 min 2 seconds over a ground track, including the left turn onto east, of approximately 5.5 nm. The aircraft's rate of descent from 3800 ft amsl to last radar fix at 1475 ft amsl was constant. Had a straight line glide been maintained the approximate impact point would have been 7nm from Boscombe Down. The FSP made 2 radio calls containing the intention to land in a field. The first was at 1032:04 hr when the FSP transmitted "*we're visual with the ground, G-Y-A-K-B probably going to be er..PFL'ing<sup>68</sup> to a field, er, West of Boscombe*". ATC replied that the surface wind at Boscombe Down was 230 degrees True at 14 kts. The second radio call was at 1033:27 hr when the FSP transmitted "*G-K-B is ma..., is PFL'ing to a field, er, just to the West of Boscombe, er, we'll phone you on the ground*". Between the 2 transmissions the aircraft maintained its easterly course. The PIC reports that the FSP transmitted the intention to land in a field after the PIC had decided to Force Land and that the accident crew began to set up an approach to a

Exhibit 19  
Exhibit 15

Witness 11  
Exhibit 21

<sup>66</sup> Calculation drawn from Exhibit 83.

<sup>67</sup> For example a shallow descent may have been achieved whilst speed was reduced to optimum glide speed.

<sup>68</sup> PFL is an abbreviation of Practice Forced Landing, the Panel formed the opinion that the FSP used the term by mistake in a stressful situation as one would use the term PFL when performing the same profile in practice.

wheat field.



**Figure 1.4.9 Aerial View of Landing Strip looking Southwest into Wind taken on 8 Jul 16**

1.4.178. The accident crew probably realised during the glide that recovery was not possible given G-YAKB's glide performance and their range from BDN, unless they successfully re-started the engine. The PIC's recollection indicates that the crew became fixated with the low fuel pressure and operation of the fuel primer handle as a means to alleviate the loss of power. This may have led to them continuing the glide to the east and not establishing a Forced Landing pattern. The FSP's radio transmission indicates that the FSP considered it likely that they would have to Forced Land at the point of the 1032:04 transmission; 92 sec after the Mayday call. The continued glide to the east, after the FSP had transmitted the intention to Forced Land indicates that the PIC had not yet committed to a Forced Landing or was selecting a landing area. By spending the time between the two transmissions continuing to glide to the east the accident crew reduced the landing surface options available to them. As shown in Fig 1.4.9 the countryside over which the accident crew flew provides multiple opportunities for Forced Landing. The PIC recalled that he saw a suitable wheat field prior to committing to the Forced Landing. The FSP's use of the word 'field' to describe the intended landing point and the PIC's description of a wheat field are consistent and indicate that the initial aiming point for the Forced Landing was a field.

Witness 11

1.4.179. The accident crew continued the glide descent to the east having realised that a Forced Landing was likely, which reduced the options of landing surfaces available to them. This was a **Contributory Factor**.

**Handling Pilot**

1.4.180. The aircraft established a glide on a steady easterly heading, descending from 3700 ft amsl to 1475 ft amsl, taking 2 minutes. The PIC recalls taking control from the FSP to exert positive g forces on the aircraft in order to free flapper valves that may have become stuck. The PIC does not recall handing control back to the FSP. The FSP made 2 radio transmissions whilst the aircraft was on a steady heading to the east. The Push To Transmit switch in the Yak-52 was located on the throttle, the primary engine control (Figure 1.4.13). The PIC reported that his memory post his attempt to free flapper valves was incomplete. Injuries sustained by both pilots indicate that both may have had their hands on their

Exhibit 19

Witness 11

Exhibit 21



respective control columns at impact.

Exhibit 110

1.4.181. The maintenance of the heading and the uniformity of the glideslope for 2 minutes indicated that the aircraft was being controlled and that one of the pilots was flying the aircraft for the glide to the east. It was possible that either the PIC was flying and the FSP was making radio transmissions, or that the FSP was flying and making the transmissions. The PIC's intention was to fly the Forced Landing but hand over control in the latter stages. The PIC has no memory of having done so. The Panel was unable to conclude who flew the Forced Landing as both pilots sustained injuries that could have been caused by either controlling the aircraft at impact or holding the control column lightly whilst the other pilot flew. This was a common practice and was termed 'following through'. The Panel was unable to rule out the possibility that a hand over of control was attempted unsuccessfully and that no one was actually flying the aircraft at impact. ie both pilots may have been 'following through'. Equally both pilots may have thought that they were controlling the aircraft at the point of impact.

1.4.182. It was probable that both pilots had their hands on the control column at impact; the Panel was unable to rule out the possibility that both pilots were attempting to control the aircraft or the possibility that no-one was flying the aircraft.

#### Energy Available at Final Radar Position



**Figure 1.4.10. Aerial View Overhead the Landing Strip and looking southwest taken on 8 Jul 16**

1.4.183. The impact point was directly upwind of the final radar position. At the final radar position G-YAKB was heading east. There was sufficient height available from this position to conduct a 150° right turn, losing approximately 300ft in the manoeuvre<sup>69</sup>, leaving the

Exhibit 19

<sup>69</sup> If flown at the 45 degree AOB recommended in Yak documentation.



aircraft approximately 800ft above the terrain. This would in turn result in enough energy to glide in a straight line for approximately 1500m<sup>70</sup> horizontally prior to impact with the ground. Any further manoeuvre or deviation from the ideal glide speed and angle of bank would reduce these figures.

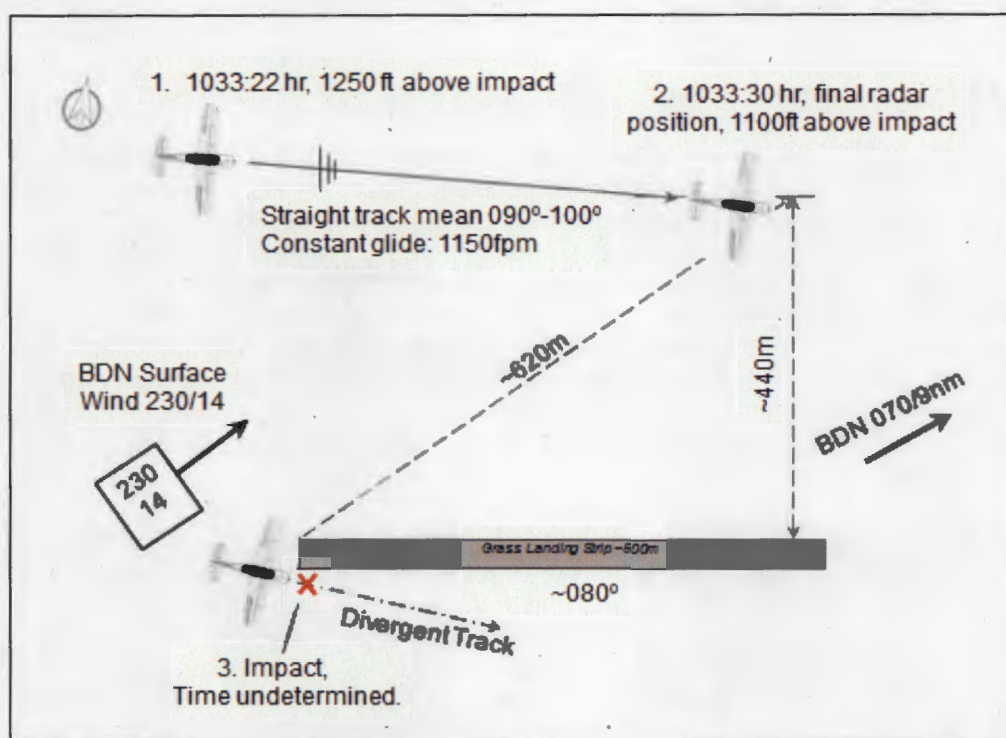

Figure 1.4.11 Plan View of Last Stages of Flight of G-YAKB, the Grass Landing Strip and the Point of Crash Site

1.4.184. The final radar position did not represent the last possible moment for a turn into wind to be achieved; however, it was close to the last point from where it was practical to execute a turn into wind and establish a safe final approach into a selected field. On balance of probability the relative position of the impact point from the final radar position is most likely to be due to a turn into wind to Forced Land. The accident crew waited until close to the last practical moment before turning into wind for the Forced Landing.

#### Abandonment

1.4.185. The accident crew were wearing parachutes which would have allowed abandonment from the aircraft and resulted in a fully developed canopy if parachute activation was achieved approximately 300ft above ground level. The PIC had suffered 3 engine failures previously in the Yak-52 and successfully landed the aircraft in these cases. The Panel was not provided with any evidence to suggest that abandonment was discussed. The PIC's parachute harness was found to be undone by the first person to render assistance post impact.

1.4.186. RAF and civil training prioritises a forced landing above abandonment in all but a few circumstances in order to reduce injury to aircrew, prevent unnecessary risk to persons and property on the ground and to save the aircraft. The PIC's experience included previous successful forced landings and there was no reason to believe that the terrain or

Exhibit 111

Witness 11  
Witness 10

<sup>70</sup> The Yak-52 has a published glide ratio of 7:1. Approximately 1700m would be achieved in still air.

weather precluded a successful forced landing; therefore, it would not have been appropriate to have risked abandonment. It is possible that the PIC had failed to secure his harness pre-flight. It is unlikely, given his injuries, that the PIC released his parachute harness himself post-impact. The Panel was unable to rule out the possibility that the PIC knew his parachute was not secured in flight and that this could have affected any decision to abandon.

#### **Forced Landing Actual Impact Point**

1.4.187. The aircraft was discovered on the southern edge of a prepared landing strip, approximately 620m south west of the final radar position (Figure 1.4.11). The landing strip surface was prepared grass. The fields to either side of the strip were planted with ripening wheat. The aircraft had arrived downwind, and had impacted left wing first. The PIC told a responder that he was aware that there was a strip. The PIC reported that either he or the FSP said that they could see an airstrip. The PIC does not recall when this was said and has no accurate recollection of the aircraft's position relative to the airstrip at the time. The PIC expressed the opinion that a strip, irrespective of the orientation, would be a preferable option to a wheat field. The PIC also stated "*It would have been my decision as PIC to go for the strip*". The PIC has no recollection of controlling the aircraft towards the strip or of having directed the FSP to do so.

Witness 11

1.4.188. The Panel considered the proximity of the impact point to a prepared air strip, the likely contrast of the strip surface to the standing wheat on either side of it, the PIC's statement, the downwind arrival of the aircraft and that the aircraft was not wings level on impact. Given the crews' experience it was unlikely that either crew member would turn downwind to land unless there was a compelling reason to do so<sup>71</sup>. The Panel considered it unlikely that the accident crew would be manoeuvring beyond small angles of bank close to the ground unless there was a compelling reason to do so. A highly plausible explanation for the aircraft impacting the ground left wing first, downwind, next to a strip is that the accident crew were attempting to land on it having changed their intended landing area from a field to the strip.

#### **Velocity at Impact**

1.4.189. The aircraft impacted the ground 4 times along an easterly axis (Figure 1.4.12). The mean line between the impacts was divergent from the axis of the farm strip. The first impact had made a mark in the ground approximately 5 cm deep and 30 cm long. The subsequent impacts had flattened standing crops but not marked the ground. The crop between the impact points was undamaged. The distance between initial impact point and final resting place of the aircraft extremities was 33m. AAIB investigations determined that the propeller speed at impact was low and in turn indicated a low aircraft speed; however, the Stall Warning light was not lit. A glide speed of 160 km/h equates to 44.4m per sec (m/s). The wind speed at Boscombe Down was 230 degrees True at 14 kts with higher gusts.

Exhibit 69

<sup>71</sup> Noting the potential for un-serviceable gyro compasses to confuse the accident crew.





**Figure 1.4.12 Aerial View of Crash Site Showing Impact Points**

1.4.190. G-YAKB would have experienced a wind component of approximately 9 kts or 4.6 m/s along the impact axis. Had G-YAKB been at the published glide speed this would have resulted in an impact at approximately 50 m/s horizontally and 6.5 m/s vertically. Notwithstanding the earth at the crash site being dry, the crash site was compact and the single witness mark indicated that there had been both a low horizontal and vertical component of the velocity at impact. The damage to the propeller indicated low speed at impact; however, the Stall Warner light being extinguished indicated that the aircraft may have still been in controlled flight at impact. It was not possible to determine the height the aircraft achieved between impacts other than it is likely that the aircraft rose vertically between impacts in such a way as to leave the crop undamaged. The impact axis indicated that the aircraft approached from the West. It was not possible to determine the aircraft's energy at impact or decelerations experienced in the crash sequence without a modern functioning Air Data Recorder<sup>72</sup>; therefore, it was not possible to deduce whether the aircraft impacted the ground in wing borne flight or that the aircraft stalled from low altitude. It is possible that a stall that occurred in a number of attitudes could have led to the left wing impacting first. Although the aircraft was travelling in an Easterly direction at impact it was not possible to deduce the aircraft's flight path between last radar position and impact. As the impacts were made by an aircraft that was translating and rotating in both the horizontal and vertical planes it is not possible to precisely determine the aircraft velocity immediately prior to impact. The Panel could not be certain why the Forced Landing failed as it was not possible to determine whether the aircraft was stalled at impact or whether anyone was controlling the aircraft.

<sup>72</sup> The aircraft had a basic mechanical ADR that did not provide any data to the Panel.



**Decision to Attempt to Land on the Landing Strip**

Witness 11

1.4.191. The PIC believed that a strip, irrespective of the orientation, would be a preferable option to a wheat field. The decision to land on the strip followed the crew's decision to carry out a forced landing into a field. The Forced Landing was unsuccessful.

1.4.192. The decision to abandon the original forced landing and attempt to land on the strip would have resulted in a downwind landing leading to longer float and ground run than an into wind landing. The difference between the resulting ground speeds of an into wind and out of wind landing would have been double the surface wind, or 28 kts. The impact of the aircraft alongside the strip, manoeuvring at low speed indicates that the landing on the strip was probably attempted from a starting point where the available energy (a combination of height and speed) was insufficient for it to be successful. Notwithstanding insufficient information to determine the aircraft's flight path exactly, it was probable that the accident crew had a window of opportunity to reverse the decision to land on the strip by rolling wings level, maintaining glide speed and landing. This would probably have resulted in a wings level and successful Forced Landing. In deciding to attempt to land on the strip, at the point that they did, the accident crew reduced the probability of a successful forced landing.

1.4.193. The decision to attempt a landing on the farm strip was a **Contributory Factor**. As the Panel were unable to determine with certainty whether the aircraft impacted the ground under control, in wing borne flight or having stalled, the failed Forced Landing attempt following an unexplained loss of thrust was found to be the **Causal Factor**.

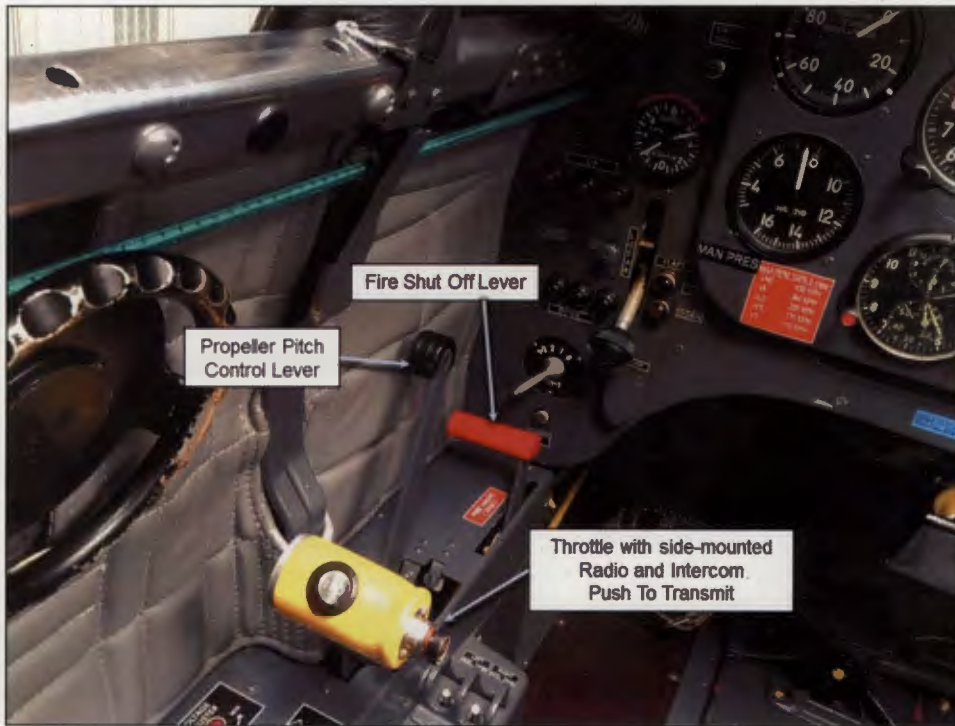

**Figure 1.4.13. Yak-52 Front Seat Cockpit Engine Control Levers similar to that in G-YAKB.** (Note: The Fire Shut Off Lever was black in G-YAKB.)

**Position of Fire Shut Off Lever**

1.4.194. A Fire Shut Off Lever (FSOL) was located in both cockpits in the Yak-52. The 2 FSOLs were vertically-aligned levers. Both rotated about a fulcrum mid-point. The 2 were



joined at the bottom end by a Bowden cable<sup>73</sup> and should therefore have always matched positions. The Bowden cable in turn linked both FSOLs to the Fuel Shut Off Valve (FSOV) on the engine. Activation of a FSOL would have closed the engine FSOV. The FSOL in the front cockpit was found to be in the closed position whilst the one in the rear cockpit was in a neutral position. The FSOV was closed. The Bowden cable between the FSOLs ran inside the port side of the fuselage and was connected to the airframe at irregular intervals. The Bowden cable was free to move in the gaps between each connection. The portion of the port side of the airframe between the 2 levers deformed in the crash, compressing the cable. The cable bowed out between successive connections, shortening its effective length and resulting in the difference in position of the FSOLs. As shown in Figure 1.4.13, the FSOL was the same shape as the throttle and moved in the same sense as both the throttle and RPM lever - fore and aft. The throttle was yellow in G-YAKB and the FSOL black. The FSOL was smaller than the throttle. The FSOL was normally stiffer than the throttle and was located forward of the throttle.

Exhibit 69

1.4.195. Operating the FSOL would have cut the fuel supply to the engine, resulting in a reduction in fuel pressure and subsequently stopping the engine a number of seconds after lever operation. This would result in the loss of thrust as described by the PIC. Apparent engine failure would have followed a period of time after lever operation – thereby reducing any obvious link between lever movement and engine failure. Activation of the FSOV would not have allowed operation of the primer pump in the left position. As the Panel could not be certain that the primer pump was in the left position it is not possible to determine when the FSOL was moved or whether it was the FSP that moved it. It is unlikely but possible that the FSP operated the front cockpit FSOL by accident. This could have been due to mistaking it for another control or by an item of Aircrew Equipment Assembly (AEA)/clothing interacting with it. The FSOL may have been operated by the FSP as a sensible precaution prior to impact. The FSOL may have been moved by airframe deformation during the impact.

Exhibit 148

1.4.196. Whilst the activation of the FSOV would have produced the loss of thrust reported by the PIC the Panel was unable to conclude when the FSOL was moved and therefore could not conclude whether the position of the FSOL had any bearing on the accident.



**Figure 1.4.14 G-YAKB in formation, showing under-carriage fully retracted.**

<sup>73</sup> A flexible cable used to transmit force by the movement of an inner cable relative to a hollow outer cable housing.



(Source: The Owner.) The Panel noted the variety of head protection worn in the photograph and in particular that the FSP in G-YAKB appears to be wearing a UK military flying helmet. The accident crew's head and face protection is considered in paragraph 1.4.204 and subsequent paragraphs.

### Position of the Landing Gear Control Lever

1.4.197. The Yak-52 landing gear position was controlled by the vertical movement of the Landing Gear Control Lever (LGCL) between the 'Extended' or 'Retracted' position. With the rear cockpit LGCL in the neutral position, control was limited to the front cockpit. The LGCL was prevented from moving by the Landing Gear Cock Ratchet (LGCR). In order to move the LGCL the LGCR had to be moved to the left. Once the LGCL was in the desired position the LGCR was returned to the right hand 'locked' position. The rear LGCL was in a neutral position. The front cockpit LGCL was found in the 'Extended' position with LGCR in mid-position. The LGCL had made a dent in the surrounding metal alongside the Landing Gear Extended advisory lights. The landing gear in the Yak-52 took approximately 15 seconds to deploy from selection to being locked down. The main gear was discovered folded under the wings on G-YAKB. The port main gear leg was in the locked position. The starboard main gear leg was unlocked. Yak-52 pilot notes stated that the approved technique for a forced landing in a Yak-52 was to leave the landing gear up. This reduced the risk of the aircraft rotating forwards on an unprepared surface.

Exhibit 82

Exhibit 69

Exhibit 82



**Figure 1.4.15 G-YAKB Front Cockpit Landing Gear Cock Lever in post-accident position. (Source: AAIB.)**

1.4.198. The dent made by the LGCL in the surrounding metalwork indicates that it had been in the down position at impact. Yak-52 expert opinion is that the nose gear leg was probably unlocked at the time of impact and that significant damage to both the undercarriage and wing would have occurred had the main gear legs been locked down at impact. There was no evidence of such damage. It is highly unlikely that the LGCR and LGCL could move to the final positions on impact. Given the unlocked status of the starboard and nose wheel legs it is most likely that the FSP selected the LGCL to down and that constituent parts had unlocked but were not locked down prior to impact. This indicates that the selection was made in the last 15 sec of flight. With no further evidence available to the Panel it is impossible to conclude why the LGCL was found in the extended position.

Exhibit 69



1.4.199. The lowering of the landing gear represents a divergence from published guidance which the panel was unable to explain. It may indicate that the FSP had not been adequately prepared for his role in a forced landing. As the aircraft impacted left wing first the position of the Landing Gear Control Lever had no effect on the outcome of the Forced Landing and the lowering of the landing gear was an **Other Factor**.

**Engine Malfunction Investigation**

1.4.200. The AAIB was unable to find a definitive cause for the engine failure.

Exhibit 69

**SURVIVAL ASPECTS**

**Aircrew Restraining Harnesses**

1.4.201. The 5-point harnesses in each cockpit comprised 2 shoulder straps, 2 lap straps and a negative-G strap secured by a 'cone and pin' locking mechanism. Replacement of a previous harness type was mandated in CAA MPD 1997-020-R1.

Exhibit 69

Exhibit 112

a. Both rear cockpit shoulder straps parted under load above the adjustment buckles. The rear cockpit left lap strap parted under load inboard of the adjustment buckle. The PIC's head and face impacted the aircraft coaming. The PIC suffered [REDACTED] injuries.

Exhibit 69

b. The front seat right hand shoulder strap failed under load below the adjustment buckle. The front seat negative-G strap parted from the airframe at its attachment point. The front seat harness locking mechanism released in the impact sequence. The FSP was ejected from the cockpit and was pronounced dead at the scene by an appropriately qualified person.

Witness 17

c. Parts of the aircrew restraining harnesses were noticeably sun faded.

Exhibit 69

d. Originally the harness would have been made of natural fibre surrounding nylon. Some of the straps had been replaced. Synthetic sections had been used to replace natural sections. There was no record of when this activity had been carried out.

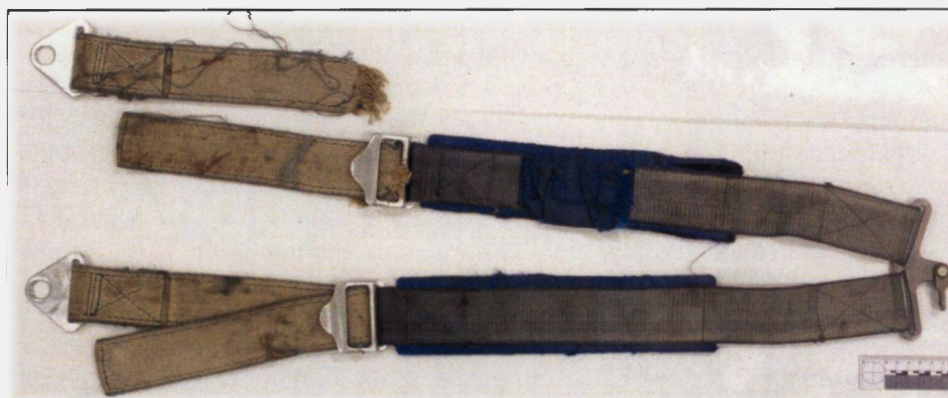

**Figure 1.4.16 The Front Seat Shoulder Straps from G-YAKB**

e. The fixed parts of the shoulder straps, above the adjustment buckle, and negative-G straps were made of synthetic fibre. The adjustable sections of the shoulder straps, below the adjustment buckle, and the lap straps were made of natural fibre.



**Figure 1.4.17 A Front Seat Lap Strap from G-YAKB**

f. The Yak manufacturer, Aerostar, does not know what the original design strength was for the harnesses. Stress test of 2 harness sections from G-YAKB, in comparison to a replacement harness section, resulted in the straps failing at 17% and 21% of the failure load of the replacement item. The Panel noted that the tested straps would have received significant loads in the crash sequence, which may have affected the post-crash tests. Aerostar use a 20 year life for the harness based on aircraft life being 20 years; G-YAKB was 24 years old.

Exhibit 113

Exhibit 114

g. There was no type design standard for the harnesses in a Yak-52. There was no calendar life for harnesses mandated by CAA or EASA. Whilst there was an EASA Certification Specification (CS) that identifies static and dynamic load conditions to be achieved in the design of protection for occupants of aerobatic aircraft<sup>74</sup>, the Yak-52 has not been certificated by EASA; therefore, the requirement was not applicable to the harnesses in G-YAKB. The only UK national guidance on harnesses was contained in CAA CAP 562 'Civil Aircraft Airworthiness Information and Procedures', which referred only to the orientation of stitched joints<sup>75</sup>. There was a requirement in the CAA Light Aircraft Maintenance Schedule (LAMS) to "Inspect" the "seats, belts/harnesses, attachment, locking and release" every 50 flying hrs or 6 months. The worksheet for the annual maintenance carried out on G-YAKB in Feb 16 identified that the harnesses had been inspected at the time in accordance with the LAMS. The inspection of the harness' integrity was reliant on visual assessment.

Exhibit 115

Exhibit 73

h. MAA RA1240 does not include a requirement for safety equipment.

1.4.202. The aircrew restraining harness was a vital piece of safety equipment. Provision of a suitable harness is a key part of a Duty of Care. A post-mortem report following the similar parting of the shoulder straps during another Yak-52 accident<sup>76</sup>, although in a relatively high speed impact, identified that the "*chances of survival, (of) the rear seat in particular, would have been greatly enhanced had the harnesses/ attachments not failed and head protection worn.*" The inspection of the aircraft in Feb 16 resulting in the issue of the CoV could reasonably have been taken as assurance that the harnesses were safe and fit for purpose; however, the resulting CoV was not examined by an airworthiness expert nor was anyone at MOD Boscombe Down aware that only a visual inspection would have taken place. The sun faded appearance would have probably stood out during an inspection of the aircraft; however, no-one reported a concern with the harnesses, other than unfamiliarity with a cone

<sup>74</sup>EASA CS-23 'Normal, Utility, Aerobatic and Commuter Aeroplanes' available at: <https://www.easa.europa.eu/document-library/certification-specifications/group/cs-23-normal-utility-aerobatic-and-commuter-aeroplanes#group-table>.

<sup>75</sup> [http://publicapps.caa.co.uk/docs/33/CAP562\\_Is4\\_Am1\\_28FEB2017.pdf](http://publicapps.caa.co.uk/docs/33/CAP562_Is4_Am1_28FEB2017.pdf), 'APPENDIX 25-5 Seat Belts' in Light Aircraft - Orientation of Stitched Joints', accessed on 20 Mar 17.

<sup>76</sup> AAIB Report into crash of Yak-52 Registration RA01337 on 20 Mar 94 estimates that the aircraft impacted the ground at approximately 200 kts.



latch. The parting of the rear cockpit shoulder straps resulted in the PIC's head interacting with the aircraft. The parting of the FSP's negative-G strap (which occurred as his seat was forced forward in the crash sequence) allowed him to slide forward in the cockpit at the same time as the engine block was pushed backwards by impact forces. The Panel was unable to determine how the harness locking mechanism in the front cockpit released; however, the parting of the front cockpit shoulder strap indicates that the harness was locked initially. The parting of the strap and coincident release of the harness allowed the FSP to be ejected from the cockpit. The FSP probably received injuries due to flail following the failure of his shoulder strap and also from impact with the ground following ejection from the aircraft. It is not possible to state that had the FSP been restrained he would have survived.

Exhibit 110

1.4.203. Whilst the Panel was unable to conclude that the FSP would have survived had he been restrained, the Panel was able to conclude that the failure of the PIC's harness straps led to significant injuries that otherwise wouldn't have occurred. The Panel determined that this was an **Aggravating Factor**.

#### **Aircrew Equipment Assemblies – Helmets**

1.4.204. Neither pilot was wearing a helmet with a visor. The FSP was wearing a Bose headset, his UK military-issue flying coverall and flying boots for the sortie. The PIC was wearing his own Campbell<sup>77</sup> Aero Classics hard shell flying helmet<sup>78</sup> with integrated communications, goggles, flying clothing and boots. The PIC was sitting on a high visibility jacket that had been borrowed from the Contractor as a booster cushion. The Aero Classics Warbird helmet (an upgrade from the PIC's helmet model) had been assessed by RAFCAM for suitability for use by Battle of Britain Memorial Flight (BBMF) aircrew. The report concluded that *"the energy attenuation provided by the Warbird helmet is poor, and is grossly inadequate compared with the attenuation afforded by in-service aircrew helmets. From an impact protection perspective it is the opinion of RAF CAM that the helmets should not be recommended for use by the BBMF."* No student reported an issue with the headsets during the week but in the phase debrief (which occurred after the accident) concerns were raised about the lack of helmets. This was recorded on the phase debrief sheet. The AAIB database contained a report<sup>79</sup> into a Yak-52 occurrence which concluded that had a helmet not been worn the *"accident would most likely have resulted in fatal injuries."*

Exhibit 116

Exhibit 117

1.4.205. The FSP and PIC were wearing different headwear:

a. The crew's choice of head protection was incoherent with their decision to wear parachutes, in that there was a risk of interaction with the airframe during abandonment and further risk of head injury in a parachute landing: wearing a helmet mitigates both. There was also a risk that the pilots' heads would interact with the cockpit structure even in normal operations, particularly in an aerobatic aircraft: a helmet would mitigate this risk. The use of a headset instead of a helmet for a parachute equipped aircraft created a risk that was not identified, captured or mitigated. No audit trail is available that demonstrates why a headset was thought sufficient in place of a helmet. This could, however, have been captured in a safety case for the activity.

b. The RAFCAM report states that had a helmet and visor combination been worn by the FSP, it could have mitigated his injuries but is inconclusive as to whether the crash would have been survivable. The construction of the Aero Classics helmet worn by the

Exhibit 110

<sup>77</sup>Campbell Aero Classics are a helmet manufacturer based in Loburn, New Zealand.

<sup>78</sup> CAM/LR/HFBS/01/07 Impact Assessment Of The Warbird Helmet For Use On The Battle Of Britain Memorial Flight 11 Apr 07.

<sup>79</sup> G-YAMS 27 Dec 04



PIC provided considerably less impact energy attenuation than the standard helmets typically worn in UK military aircraft. Had the PIC been wearing a helmet with greater energy attenuating properties then it is possible that his injuries would have been further reduced, particularly if the helmet were worn with visors, of an appropriate standard, in a locked down position.

1.4.206. It is possible that the wearing of a suitable helmet would have mitigated injuries sustained by both of the accident crew. The lack of suitable helmets was an **Aggravating Factor**.

1.4.207. **Recommendation.** QinetiQ should review the requirement to wear appropriate head and face impact protection by crews operating third party aircraft, in order to discharge a component of their Duty of Care.

#### **Aircrew Equipment Assemblies – Rudder Pedal Straps**

1.4.208. G-YAKB was equipped with standard Yak-52 rudder pedal/swing bar foot straps. These straps hold the pilots' feet on the rudder pedals. No integration assessment of the interaction between the straps and the range of UK flying boots worn by the ETPS personnel had been carried out. As no integration assessment had been conducted, any risks posed by the straps were not known.

Exhibit 83

#### **Aircrew Equipment Assemblies – Parachutes**

1.4.209. Both pilots were wearing a Strong Enterprises 'Squadron Seat' para-cushion<sup>80</sup> which was part of the G-YAKB inventory. The G-YAKB airframe log book did not record the condition of safety equipment provided with the aircraft. The labels on the para-cushions showed that they had been manufactured in Jan 08. The 'Parachute Packing Data Card' showed that they had both been repacked on 27 Nov 15. The packing card gave a packing cycle of re-pack every 120 days but the Strong Enterprises Owner's Manual had a 365-day repack cycle<sup>81</sup>. The applicable parachute legislation identified that:

Exhibits  
118-123

- a. The ANO contained no specific UK regulations for emergency parachutes.
- b. EASA publications stated that "*emergency parachutes are neither installed on aircraft as a component nor are they required by Commission Regulation (EU) No 965/2012 (Air Operations).*"
  - 1) *Emergency parachutes are not subject of EC Regulation No. 1321/2014 (Part M).*
  - 2) *The owner of the emergency parachute is responsible for keeping the emergency parachute in a proper condition in accordance with the approved instructions published by the manufacturer.*<sup>82</sup>

Exhibit 5

1.4.210. The Panel found when investigating the actual life of the para-cushions that notwithstanding the 120-day repack cycle shown on the parachute packing data card, the Owner's Manual required them to be serviced every "365 days unless local regulations regulate otherwise." Whilst there were no local regulations in force to alter the periodicity, no evidence was presented to the Panel that the condition of the parachutes had been checked

<sup>80</sup>Strong Enterprises are a parachute manufacturer based in Orlando, Florida.

<sup>81</sup><http://www.strongparachutes.com/docs/?et=Emergency> accessed on 13 Jan 17.

<sup>82</sup><https://www.easa.europa.eu/faq/19472> accessed on 20 Mar 17.

or that the information on the data cards had been researched and the correct date for packing cycle identified. The parachutes would have appeared to be out of date for servicing to anyone checking them at BDN. Only a physical equipment and documentation check by SQEP can result in an assurance of the condition and suitability to task of a third Party aircraft's safety and emergency equipment. It was most likely that ETPS personnel did not check the parachute packing cards. The parachutes being out of date for their stated packing cycle would have been conspicuous to anyone checking the parachute for serviceability. It was unlikely that professional aircrew would fly with out of date parachutes. Therefore the Panel concluded that no QE participant that flew in G-YAKB checked the parachutes.

1.4.211. The omission of a check of parachute serviceability was a failure in the discharge of a Duty of Care by the PIC and FSP to themselves and was an **Other Factor**.

1.4.212. **Recommendations.** The D MAA should review the regulations relating to hire or charter of third party aircraft in order to provide assurance that third party aircraft and their equipment are safe. The review should include the requirement for the organisation hiring the third party aircraft to confirm and record that:

- a. The safety and emergency equipment provided with the aircraft is appropriate and fit for purpose.
- b. The personnel flying in the aircraft will wear appropriate clothing, protective clothing and Aircrew Equipment Assemblies.
- c. An appropriate assessment of the third party aircraft has been undertaken to identify any idiosyncrasies that could affect Flight Safety.

#### **Abandonment and Egress Training**

1.4.213. ETPS written orders for QE stipulated that participants were to be content with emergency procedures prior to flight. Normal and emergency egress were discussed as a group at the aircraft but individual abandonment drills were not rehearsed from the cockpit and not all participants remained at the aircraft for the whole brief. An experienced pilot who attended the classroom Technical Brief, the Cockpit Safety Brief at the aircraft and carried out his own pre-flight aircraft research was not familiar with these actions, including normal operation of the canopy, until strapping in for the actual flight. To become familiar this pilot required the PIC to re-brief him once in the front cockpit. Another experienced fast jet pilot informed the Panel that he would not be confident in his ability to egress the aeroplane in an emergency.

Exhibit 46

Witness 3

Witness 6

Witness 34

1.4.214. The evidence available to the Panel indicated that the egress training prior to QE was insufficient. The Panel questioned why other QE TP and FTE students did not raise this issue. It was possible that the 2 pilots had a level and breadth of experience of operating different aircraft types which increased their individual awareness. Alternatively it was possible that, as fast jet pilots, their experience with assisted escape equipment led to them scrutinising their escape system to a greater degree than others. Nonetheless, this indicated to the Panel that the level of training in the Safety and Technical Briefs prior to the actual flight were insufficient. The FSP did not benefit from the Safety and Technical Briefs or cockpit familiarisation; therefore, not as well prepared as the QE aircrew to egress the aircraft in an emergency.

1.4.215. The insufficient preparation by QE aircrew, which resulted in them being unlikely to be able to abandon the aircraft in an emergency, did not affect the outcome in this instance, but was an **Other Factor**.

**OFFICIAL SENSITIVE**

1.4.216. **Recommendation.** CO ETPS should amend local orders, prior to the next QE, directing that all personnel practice emergency egress and abandonment before their first flight in a new aircraft type, in order to prepare them for flight.

**POST ACCIDENT EVENTS**

**Command and Control**

1.4.217. A Boscombe Down based Gazelle helicopter followed the accident aircraft pre-impact and found the crash site shortly afterwards. Initial Command and Control was exercised by the Aircraft Captain of the Gazelle. Subsequent formal Command and Control at the crash site was the responsibility of the Wiltshire Police, assisted by the AAIB as the investigating authority. A local 'Silver Control' Command Centre was established at MOD Boscombe Down.

Witness 10

Exhibit 25

Exhibit 27

**Damage to Aircraft, Public and Civilian Property, and Personnel**

1.4.218. G-YAKB was a civil registered aircraft which incurred significant damage from the impact with the ground; it was insured for 'club uses'. The accident was assessed by the insurance brokers Hayward Aviation Ltd. There were no aircraft-related costs attributable to the MOD. In terms of other damage:

Exhibit 64

- a. **Public property.** Other than the loss of the FSP's Service supplied flying equipment there was no damage to public property.
- b. **Civilian property.** The accident site was civilian property. G-YAKB was a civil-registered aircraft; responsibility for managing any subsequent remediation of the crash site rested with the insurers or aircraft owner. There were no civilian property related costs attributable to MOD.
- c. **Personnel.** The insurer's commercial activity to assess the cost of injury to and death of personnel was beyond the scope of this investigation. The RAF has lost an experienced operational pilot, instructor and Experimental Test Pilot Instructor whilst the PIC suffered serious injuries.
- d. **Damage to the environment.** The Wiltshire Police at the scene reported "*not too heavy environmental impact*". The Police log recorded that their link to the Environmental Agency was not being activated. An independent report commissioned by the AAIB assessed the fuel loss to be a maximum of 5.5 litres; retrospectively acknowledged to be an approximate estimate. The AAIB's analysis of the stretched filaments in the fuel gauges after the accident suggested there were approximately 80-85 litres of AVGAS LL in the aircraft when it crashed. The fuel probably leaked out through the severed aircraft fuel system pipework before evaporating or being absorbed by the chalk beneath the crash site.

Exhibit 25

Exhibit 124

Exhibit 69

**Emergency Response**

1.4.219. A detailed record of the incident response to the accident is at Annex A. The accident occurred in a location 9nm from BDN without direct access from public roads. The response to the accident involved multiple assets. Initial responders were guided to the crash location by the Gazelle. Aerodrome Rescue Fire Fighting (ARFF) services were required by RA3261. A reference within RA3261, JSP 426 Vol 3 Leaflet 2 was not accessible in the same location as the JSP itself. RA3261 stated that: "*When a crash takes place off an aerodrome, and the location is known, controllers should take action in accordance with Local/Unit Orders*"; JSP 426 Vol 3 Leaflet 2 contained a similar regulation and stated that "*DATCO/ATCO IC or other emergency coordinating body will initiate*

Witness 36

Exhibit 125

Exhibit 7



emergency action in accordance with unit orders.” The MOD Boscombe Down Defence Aerodrome Manual (DAM) stated that “The ERP has been produced with guidance contained within the MPCM<sup>83</sup>, RA1400<sup>84</sup> and JSP 426” but contained no further orders. The MOD Boscombe Down ERP stated that “Boscombe Down has no responsibility to provide PCM<sup>85</sup> to an offsite incident; however initial lifesaving response may be provided by the QinetiQ Fire Service and medical section”. The ERP does not have any explicit orders for response to offsite incidents but does contain PCM guidance. The ERP summary of “Out of Hours Duty Flying Executive Scenarios and Responsibilities” for “Incident Off-Site BDN based crew/aircraft” identified “Passage of info only” as the only required action following an incident to an aircraft operating from Boscombe Down. Local understanding at MOD Boscombe Down was that attendance at an emergency was only required out to 1000m from the perimeter. Deployment of QinetiQ Fire service followed a discussion between the Station Fire Officer (SFO) and ATC after the SFO requested clearance from ATC to deploy to the crash site.

Exhibit 126  
Witness 36

1.4.220. No clear order directing whether crews should respond to the accident existed. Although the crash site was more than 1 km away from the airfield, there was no legislation or policy that mandated a 1000m delineation for response; instead, ICAO<sup>86</sup> and CAP 168<sup>87</sup> advice was that units should be familiar with the geography within 1000m of the airfield boundary for crash response, and that certain planning considerations were appropriate out to 1000m. The Panel believed that over time the ICAO advice to be familiar with the airfield surrounds out to 1000m had metamorphosed into an unwritten belief that this is the geographical limit of responsibility. COs and managers owed a Duty of Care to the accident crew and to the emergency responders, in relation to the hazards associated with the aircraft and the potential risk that these might pose to rescuers. The scale and type of resources provided by MOD Boscombe Down had to be appropriate for the incident, balanced with the risks associated with continued operations at the airfield. Due to the location of the site and the awareness of occurrence, the assets at Boscombe Down were well-placed to respond. It was the COs’ and managers’ responsibility to assess whether reliance on civilian services to respond to an occurrence was appropriate. A Duty of Care does not cease at aircraft impact; equally there is no geographical or time limit to a Duty of Care. Incident response and PCM are 2 different activities and should not be conflated in orders.

1.4.221. There was no policy for the immediate response to off-site aircraft crashes which led to incoherence in orders, confusion at MOD Boscombe Down and delayed the response to this accident. This was an **Other Factor**. Whilst the omission in the MOD Boscombe Down ERP of an explicit requirement to respond, was incoherent with the Duty of Care, it did not affect the outcome of the accident; therefore, it was an **Other Factor**.

1.4.222. **Recommendation.**

- a. The Defence Fire Risk Management Organisation should issue policy for response requirements to all MOD aircraft operating sites in order to remove reliance on local orders.
- b. The D MAA should review stakeholder understanding of, and delineation between, incident response and PCM in order to remove confusion.

<sup>83</sup> Manual of Post Crash Management

<sup>84</sup> RA1400 was concerned with Flight Safety, the Panel is unsure of its relevance to immediate response.

<sup>85</sup> Post Crash Management is completely distinct from immediate response.

<sup>86</sup> ICAO Runway Risk Reduction Document 2<sup>nd</sup> Edition.

<sup>87</sup> <https://publicapps.caa.co.uk/docs/33/CAP%20168%20Licensing%20of%20Aerodromes.pdf> accessed on 20 Mar 17.

### Safety and Health Aspects of the Response

1.4.223. The Boscombe Down Fire Service had not received a brief on a G-YAKB when it arrived at Boscombe Down and did not have Yak-52 specific hazard information. Some external responders to the crash scene were unfamiliar with MOD procedures and equipment. At the crash scene a member of the emergency services attempted to ascertain whether aircraft power could be isolated prior to extraction of the PIC; neither the PIC, nor the Gazelle Aircraft Captain in attendance knew. The responders undertook the extraction of the PIC, judging the risk to their own lives and health to be acceptable in the circumstances. The Dorset and Wilts District Fire Commander was unaware of the capabilities of QinetiQ Fire Service appliances.

Witness 10

Witness 36

1.4.224. Power isolation, along with all pertinent rescue information, should be contained in an aircraft hazard data sheet. The Boscombe Down Fire Service had access to the MAA Hazard Database and had built up a civilian aircraft hazard catalogue for civil-registered aircraft based at the airfield but, as a visiting aircraft type, Yak-52 aircraft were not included. In the event of an occurrence involving an aircraft operating from an MOD airfield, the local civilian emergency services will probably be unfamiliar with airframe specific fire fighting requirements and the implications of the hazardous items, materials<sup>88</sup>, cargo or hazardous stores. They may also reasonably expect to receive this and other information from the aerodrome from where the aircraft was operating. These details were already captured in the MAA database for UK military aircraft. The incident highlighted the lack of collective training between Defence and civilian response organisations, despite Defence relying on the civilian response.

1.4.225. Without understanding the hazards associated with the aircraft, the emergency services had to extract the PIC at their own risk and this was an **Other Factor**.

#### 1.4.226. Recommendations:

- a. The D MAA should implement a system whereby MOD airfields must receive hazard information from visiting aircraft types, for dissemination to emergency services in the event of an occurrence, prior to issuing permission for them to operate from or visit the airfield.
- b. The D MAA should consider a requirement for the COs of each MOD airfield to establish and maintain training with local civilian response organisations.

### Post-Crash Management (PCM)

1.4.227. The Police and AAIB did not hand over primacy of the site to the MOD, as the crash was a civil air accident; therefore, there was no requirement for PCM. The MOD Boscombe Down PCM Incident Officer (PCMIO) was despatched to the crash site by Wg Cdr Flying in a liaison capacity. The crash site was within RNAS Yeovilton's PCM responsibilities; however, the assets from the Unit were not required.

Exhibit 27  
Exhibit 127  
Exhibit 29  
Exhibit 27

### Salvage Operations

1.4.228. The Joint Aircraft Recovery and Transportation Squadron (JARTS) recovered the wreckage from the site on 9 Jul 16. Under the direction of the AAIB, JARTS used

Exhibit 29

<sup>88</sup> For example typical hazards might include: the presence or absence of ejection seats, crew restraint specifications and any other hazards, AVGAS/AVTUR and components made of Man Made Mineral Fibre (MMMF).

mechanical cutting equipment to separate the aircraft into transportable sections<sup>89</sup>. The salvaged material was initially recovered to MOD Boscombe Down<sup>90</sup> before being delivered to the AAIB at Farnborough the following week. On 9 Aug 16, at the request of the Panel, JARTS undertook a further visual search of the crash site approximately 250m along the projected extended path of the crashed aircraft, looking for projected material: further pieces of canopy material and a solenoid valve were found within 15m of the crash site. Following harvest, a final search by JARTS on 15 Aug 16 revealed no further debris.

Exhibit 128

## SUPERVISION AND SAFETY CULTURE

### Supervision of Qualitative Evaluation Sorties

1.4.229. The flight was conducted under ANO Legislation. There was no requirement to authorise a flight in the ANO.

1.4.230. The ETPS supervisors were not able to supervise the PIC in a strict regulatory sense as his Yak-52 operations fell outside of their supervisory AoR; however, they were able to supervise the QE from the perspective of assessing the activity and reviewing ETPS participation in it. The PIC believed that he was assessed by ETPS pilots during the QE familiarisation flight. The ETPS FW tutor was not required to assess the PIC; instead, he demonstrated the QE profile to the PIC. ETPS supervisors were able to suggest or order the cessation of ETPS participation in QE had they perceived any reason so to do. Outside of any regulatory role ETPS supervisors and students alike were able to offer the PIC and QE participants advice and challenge as they saw fit.

### Supervisory Mechanisms

1.4.231. The following ETPS supervisory mechanisms were employed, even though ETPS did not directly supervise the third party activity of G-YAKB:

- a. **Aviation Task Risk Matrix.** The use and mis-use of the ATRM was considered in paragraph 1.4.134.
- b. **Warn Out.** The ETPS FOB at E2306 (Authorisation of Flights) included a 'Warn Out' form listed as 'Annex I ETPS Warn Out form'. The form at Annex I was entitled 'Boscombe Down Flight Notification'.
- c. **Out-brief.** The out-brief was a critical supervisory tool which provided a 'last chance' check that aircrew are ready in all respects for their sortie. An out-brief was usually conducted as a 'challenge and response'<sup>91</sup> between crew, command chain and nominated supervisor. The ETPS "FW Outbrief Proforma" challenges included "qualification/currency" and "crew responsibilities" and "emergency handling" for the intended sortie. The accident crew completed the out-brief; however, there is no record of the accident crew's responses to these challenges. The FSP had not attended the Yak-52 technical brief or the safety brief at the aircraft on 4 Jul 16 and

Exhibit 86

Exhibit 47

<sup>89</sup>The aircraft was separated into 5 sections comprising: the rear fuselage, aft of the back cockpit; the port wing from its root outwards from the fuselage; the starboard wing from a point approximately mid-span; the central fuselage, comprising the 2 cockpits; and the front fuselage from the forward bulkhead, including the engine.

<sup>90</sup>By coincidence JARTS was also based at MOD Boscombe Down.

<sup>91</sup> For example: It was confirmed by challenge and response that the crew had planned correctly, were medically fit and rested, were current, that relevant documentation was in date and whether there were any implications of aircraft un-serviceabilities – in addition to other, usually safety related items.



was declared as “Unqualified”<sup>92</sup> on the ATRM; these points should have been raised at the out-brief.

d. **In-brief.** The in-brief was a critical supervisory and Flight Safety tool. It was used to inform the supervisor of anything of note that occurred during the sortie, and to confirm all post flight processes are complete: for example logging of hours has been done. The FOB stated at E2306(8).1 “(OUTBRIEF/ INBRIEF PROCEDURES) The inbrief is to be carried out between the Aircraft Captain and Duty Tutor as applicable. Once the inbrief has been carried out the Aircraft Captain is to sign to this effect at the bottom of the pre-flight Warn Out...the Duty Tutor is to check all sorties have been properly ‘closed’...”. The ETPS ‘in-brief checklist’ was not a standalone item; it was contained within the FW Outbrief Proforma and is titled “Post Flight”. The checklist was not explicit as to what information the crew must pass to the supervisor and did not include a requirement to report Flight Safety Occurrences. The Panel was told by multiple interviewees that no in-briefs took place for Yak-52 QE. Seven “inbrief complete” fields on “Flight Notification” forms were not signed. Four out of 11 forms were either signed by the PIC or a ‘pp’ signature was given by the student or supervisor.

Witness 2  
Witness 3  
Witness 4  
Witness 6

1.4.232. The use of ATRMs, in-briefs and out-briefs was a sensible and well intentioned assurance measure for use throughout QE to review the activity and supervise ETPS participants, when supervision of the PIC directly was not possible. The completion and acceptance of an erroneous ATRM masked significant issues from ETPS supervisors, who could have stepped in with direction and guidance to other QE participants. Ultimately both ETPS supervisors and QE participants themselves had the ability to terminate QE sorties. A key constituent of an out-brief was the 2-way passage of information between the sortie aircrew and the supervisor concerning the serviceability of the aircraft. There was no evidence that indicated the PIC passed information about the deteriorating serviceability of G-YAKB to supervisors at in-brief or out-brief. Had ETPS supervisors been informed of the multiple failures the aircraft was carrying, it was probable that they would have ordered a review or cessation of the activity. The Flight Safety occurrences and unserviceabilities of the aircraft should have been passed immediately during the in-brief to the Duty Tutor and by any means possible to ETPS supervisors, as well as being formally reported as per RA 1410. The Panel was unable to conclude why in-briefs were not completed; however, the short in-brief checklist and requirement to in-brief, as they were captured within the out-brief and flight notification, lacked prominence. The inconsistently completed Warn Out Sheets did not indicate that a rigorous in-brief had been achieved. This meant that some forms showed an in-brief to have taken place when it hadn’t. This had the effect of providing ETPS supervisors with a false impression as to the level of review being achieved. The lack of in-briefs, coupled with the omission from the ETPS in-brief checklist of an explicit requirement to report Flight Safety occurrences and unserviceabilities, denied supervisors a critical source of information. Supervision of flying did not begin or end at any precisely defined point. It was all encompassing and would, when carried out correctly, include conversation and liaison outside the normal sortie brief-execution-debrief cycle. For example, it would have been reasonable to expect a supervisor to discuss learning points and sortie conduct with the ETPS students on an opportunity basis during QE week. The Panel noted the MRP detailed guidance for briefing topics<sup>93</sup> and no post flight guidance.

<sup>92</sup> On aircraft type.

<sup>93</sup> RA2305(5)

### ETPS Student/Staff Interaction

1.4.233. The FW QE tutor met the PIC on a daily basis throughout QE but did not liaise with the students during QE week. Following a Flight Safety occurrence<sup>94</sup> involving G-YAKB that went unreported on the first day of the QE week, the students were informally briefed by a supervisor that adherence to local flying orders was their responsibility rather than that of the PIC. No student reported taking Flight Safety concerns to a supervisor during the Yak-52 QE week despite multiple students witnessing reportable occurrences. As there was no reported reason as to why this was the case the Panel questioned whether ETPS Safety Culture was open and honest.

Witness 1

Witness 6  
Witness 7

1.4.234. It was normal within flying units to discuss and critique sortie content and occurrences, post event and outside of formal debrief. Despite the multiple unserviceabilities and witnessing of flying indiscipline, the participants of QE in G-YAKB did not communicate these observations to supervisors until too late but did discuss them between themselves. There was no proactive closing of the normal post-flight safety loop between participants and ETPS staff. HF evidence indicated that student and staff workload had suppressed interaction and certain levels of supervisory scrutiny due to alternative priorities. The Panel considered the current layout of ETPS, as well as prioritisation of workload to act as barriers to both passive and proactive ETPS Staff interaction with students.

Witness 3

1.4.235. The employment of the 'ETPS ATRM' and 'FW OUT-BRIEF PROFORMA' was a well meant attempt to replicate supervisory norms but failed to capture issues with QE activity and risks, which created a pre-flight false assurance. Furthermore, the ETPS in-brief process for QE, and wider supervision of flying, failed to bring to the attention of supervisors that Flight Safety occurrences were going unreported throughout Yak-52 QE and that G-YAKB's serviceability was deteriorating. The failure of ETPS supervisory mechanisms to capture Flight Safety issues both with G-YAKB and the QE sorties was an **Other Factor**. The ETPS FOB contained an editing error which was an **Observation**. Following the accident RAFCAM conducted a Human Factors study which considered, amongst other topics, the Safety Culture at ETPS. This study is summarised in paragraph 1.4.240.

#### 1.4.236. Recommendations.

- a. CO ETPS should amend the title of FOB E2306 Annex I, to ensure that it is consistent with the wording of FOB E2306.
- b. QinetiQ should ensure that operators of ETPS hosted third party aircraft are contractually obliged to use ETPS supervisory processes, in order to allow supervisors to review their activity.

### The Roles of Stakeholders

1.4.237. The QinetiQ CoP for the 'Use of Third-Party Aviation' required that "*QinetiQ managers must demonstrate that their planned use of third-party aviation complies with all relevant regulatory and legal requirements and that matters such as liability, responsibility and authority are unambiguously defined and understood by all participants*". Other than the Framework Agreement, the Panel was not given any evidence that a QinetiQ manager, or QinetiQ personnel collectively, had demonstrated the above. There was no evidence that anyone addressed the issue of QE in a PTF aircraft. Tasks were undertaken by disparate QinetiQ stakeholders, without a single responsible activity owner, one of whom was an ETPS tutor. The ETPS tutor had been given by his QinetiQ Line Manager:

Exhibit 60

<sup>94</sup> G-YAKB descended below Minimum Separation Distance during recovery due to weather.

a. The task of running QE. The Tutor used an ETPS spread sheet to confirm that chosen aspects of the exercise were ready. The spread sheet was not comprehensive in that it did not include contractual or airworthiness items that were outwith the tutor's TORs. The Panel noted the following:

Exhibit 117

- (1) The proposed Yak-52 QE activity had not been reviewed by the AHASP but the spread sheet stated that the AHASP certificate was in date. The exercise tutor held an honest belief that AHASP scrutiny of wider ETPS activity covered this item.
- (2) The ETPS 'Yak Pak 2016' gave a different aircraft G-limit to the PTF but the spread sheet stated that aircraft limits had been checked.
- (3) The spread sheet did not record the conduct of a familiarisation sortie.

Exhibit 129  
Exhibit 3

b. TORs that did not explicitly identify tasks to be achieved. Orders for QE phase runners are contained in the ETPS FOB E2370(7) and the QE FTS gives further orders for the execution of QE; however, the Tutor was not required by these orders to assess the PIC's competence.

Exhibit 130  
Exhibit 47  
Witness 1  
Exhibit 46

1.4.238. The requirements of the QinetiQ CoP would, in the main, be met by the production of a simple safety case for Yak-52 QE. Whilst an ETPS tutor had been put in place to run QE, his role was not explicitly captured in a single document. The delineation between, and communication requirements of, his role and those of other stakeholders was not clear. Stakeholders assumed that others were conducting necessary tasks, such as provision of a serviceable aircraft. Stakeholders also assumed that other tasks were unnecessary, such as the assurance of airworthiness documentation and the PIC's competence. Without a single person being responsible for the totality of the tasks the reality of this situation was never understood.

**Examples of Flight Safety Occurrences: Unserviceabilities and Cases of Flying Indiscipline**

1.4.239. Tables 1.4.3 and 1.4.4 respectively identify a number of aircraft unserviceabilities and cases of flying indiscipline that the Panel was informed of by witnesses from the 2016 Yak-52 QE in G-YAKB. All of the issues were reportable Flight Safety occurrences but none were reported. The PIC was acting as Safety Pilot for all sorties.

	Participant	Description as relayed to the Panel	Action Taken
1.	ETPS Student	Student noticed pre-flight that RPM gauge was u/s. Flight was flown as briefed.	No report made.
2.	ETPS Student	Student noticed that the headset he was given had been mended locally using tape, the aircraft RPM gauge in both cockpits and rear seat AI and gyro compass were u/s. The sortie went ahead.	No report made.
3.	ETPS Student	ETPS student noticed pre-flight that the RPM gauge was u/s. The sortie went ahead. ETPS student in front seat noticed that communications with PIC and via R/T were difficult. On landing it became apparent that the headset supplied by the PIC had gone u/s and had been repaired with tape.	No report made.
4.	ETPS Student	ETPS student noticed pre-flight that the RPM gauge and gyro compass were both u/s. The	No report made.

Witness 5

Witness 3

Witness 6

Witness 2



**OFFICIAL SENSITIVE**

		sortie went ahead.	
5.	ETPS Student	ETPS student noticed that the RPM gauge and AI were both u/s. The sortie went ahead.	No report made.
6.	QQ Employee	QinetiQ employee tasked to assist QE PIC observed said PIC failed to conduct a walk round.	No report made.
7.	QQ Employee	As above on a different date with different QinetiQ employee.	No report made.
8.	QQ Employee	As above on a different date with different QinetiQ employee.	No report made.
9.	QQ Employee	QinetiQ employee told by PIC that the RPM gauges were failing in both failure Modes.	No report made.

Witness 4  
 Witness 28  
 Witness 29  
 Witness 9  
 Witness 29

**Table 1.4.3 Flight Safety Occurrences**

	Participant	Description as relayed to the Panel	Action Taken
1.	ETPS Student	Whilst recovering to Boscombe Down PIC descended below published minima to maintain VMC. The PIC stated at the time words to the effect of 'the instruments are good for instrument flying' <sup>95</sup> .	Reported by ATC, not by TPS.
2.	ETPS Student	During the sortie the PIC entered an inverted spin below published minima for 'normal spinning'.	No report made.
3.	ETPS Student	PIC entered unplanned and un-briefed inverted spin below published minima for normal spinning.	No report made.
4.	ETPS Student	Once airborne the student reports that PIC performed an inverted spin below published spinning minima.	No report made.
5.	ETPS Student	FTE student landed aircraft. Minimum height for FTE control of the aircraft is 1000ft.	No report made.

Witness 7  
 Witness 3  
 Witness 6  
 Witness 4  
 Exhibit 131

**Table 1.4.4 Cases of Flying Indiscipline**

**Human Factors**

1.4.240. RAFCAM produced a Human Factors (HF) report based on evidence gathered by the Panel and by a further study conducted at ETPS following the accident. The report's recommendations were considered by the Panel and, where appropriate, included in the wider recommendations of this report. The following is a summary of the HF report findings:

Exhibit 132

a. **Workload.** Both students and staff reported that their workload was high. In the case of the staff this was attributed to course content, flying related administrative burden and plan changes due to aircraft availability. The report stated that workload would be increased if the course was running behind. No reason was given for this as running behind would only increase workload if there was a compulsion to catch up. High workload had the effect of reducing student/staff interaction and reducing the time available to prepare for sorties. Workload was also given as a reason for no time for reflection following a sortie which may have led to a lack of reporting. Workload varied over time and was also increased by a programme of change to the ETPS course. The report did not directly and unequivocally link a lack of reporting to high work load. The report acknowledged that steps had been taken to reduce or manage student workload; examples included removal of the student from the Fly Pro and

<sup>95</sup> G-YAKB is not IFR certificated.

## OFFICIAL SENSITIVE

movement of tasks. The Panel was also made aware of an increase in staff and the formation of a 'pre-course', both aimed at reducing workload. The Panel was unable to determine why stakeholders arrived at a situation where workload was allowed to detract from student/staff interaction and post-sortie reflection as these should have been prioritised.

b. **Crew Resource Management.** The report identified barriers to good CRM on QE sorties. The potential for cockpit gradients to exist during QE was also reported to the Panel by witnesses and the risk had been identified in the FTS. The report noted participants' reliance upon the PIC in an emergency situation and went on to note that there were 2 distinct descriptions of the PIC's briefed role, which created a risk that participants would be unclear about their own role in an emergency.

c. **Safety Culture.** The report stated that ETPS personnel considered there to be a good safety culture and an open and just culture at ETPS; however, it did identify further examples of a lack of reporting on QE sorties. The possible reasons for the lack of reporting were an assumption that the operator knew what they were doing; that the students did not feel it was their place as visiting aircrew to question local norms; and that they did not realise until later the scale of the indiscipline, represented by the performance of third parties, they had witnessed. The report noted that reporting was driven by the recognition of something being 'not normal'; however, the point of QE was to subject the student to an unfamiliar environment. It is an aim of TP training to normalise the abnormal. This may have meant that the ability to recognise something as being 'not normal' was diminished. When considering Yak-52 QE in isolation the Panel were unable to reconcile the opinions of witnesses that ETPS had a good Safety Culture when evidence showed that occurrences were not being reported, supervisors not applying rigour to ATRMs and in-briefs were signed for but not completed.

d. **QE Supervision.** The report noted the possibility that 2 cognitive biases may have contributed to the positive impression of the PIC at ETPS and consequently diminished the chances of a negative evaluation of him. There was no evidence of concerns regarding the PIC. QE debriefs were noted to be short due to the PIC needing to prepare for subsequent sorties, which led to lessons only being captured when a group debrief was held sometime after the exercise.

e. **QE reporting.** When specifically addressing Yak-52 QE, the report stated that reasons for a lack of occurrence reporting may have included: that no one participant (other than the PIC) would have had a complete picture of all instrumentation failures and all breaches of flying discipline; participants were confident in the abilities of the PIC; there were limited opportunities to detect and report issues; and that personnel had become accustomed to operating in abnormal circumstances and had modified their threshold for what was considered reportable.

f. **Procurement Process.** The report explained two biases which may explain the situation in the procurement process where multiple stakeholders were aware of a need to check and assure but none thought it their responsibility and all assumed that another stakeholder was actually doing the activity.

## RISK MANAGEMENT

### Joint Service Publication 815

1.4.241. The QE Risk Assessment did not include risks associated with placing ETPS personnel into an operation with no AOA or ADH, and to which the MRP did not apply. JSP

815 stated that “if the work-related defence activity is complex and/or if the consequences of failure whilst conducting the activity are significant for the health or safety of the workforce or public or for the environment, it may be appropriate to produce and document the risk assessment as a safety case; it is expected that many defence activities are in this category. The owning commanding officer or manager is to decide whether to produce such a safety case in consultation with relevant regulator(s) and recognising the requirements of legislation or Defence regulations.” The Panel found no evidence of consultation between MOD personnel and any regulator to justify not producing a safety case. There was no evidence that a safety case had been produced that considered all of the risks associated with the use of the Yak-52 for QE, or G-YAKB with the contracted PIC for the ETPS 2016 Fixed Wing Course. A Risk Assessment had been produced by ETPS, in the form of the QE FTS and Yak-52 Addendum. The operations of the aircraft on the ground and risks relevant to fire fighting were addressed in generic Risk Assessments. No Risk Assessment was produced by ETPS that identified type specific aviation hazards associated with the Yak-52; neither was such a document demanded from either CPT Ltd or the PIC.

Exhibit 46  
Exhibit 49  
Exhibit 106  
Witness 36

### QinetiQ Use of Third-Party Aviation Code Of Practice

1.4.242. The CoP stated that “Managers engaging third-party aviation are accountable for demonstrating that the proposed activity is justified by QinetiQ interest and engenders tolerable risk which has been reduced to As Low As Reasonably Practicable”. There was no evidence that a QinetiQ Manager demonstrated this however a safety case may have done so in a single simple document.

Exhibit 60

### Yak-52 Historic Occurrences

1.4.243. The AAIB database of Yak-52 General Aviation incidents reported in the UK recorded that between 1993 and 8 Jul 16 there had been 45 significant events; 6 of the events had involved a total of 11 fatalities<sup>96</sup>. Over the same period the Yak-52 fleet in the UK had grown to approximately 50 aircraft. The AAIB database included 5 incidents of engine malfunction leading to a Forced Landing, none of which resulted in fatalities<sup>97</sup>. Occurrence reporting in the UK has been governed by European Regulation 376/2014 since Nov 15<sup>98</sup> and before that the CAA’s CAP 382, neither of which mandated the recording of engine failures in flight if there were no fatalities or damage to the airframe. There were unreported engine failures that occurred during the same period, the Panel was informed of 6. A previous Yak-52 QE at BDN had resulted in a reported propeller strike.

Witness 7

### Risk Assessment

1.4.244. QE Flight Test Schedule (FTS) and Yak-52 FTS Addendum. The QE FTS Addendum directed crews to “ascertain the general operating hazards of an aircraft from the operator”. The Yak-52 Addendum contained 2 risks, each with 2 considerations. These were almost identical to those for the PC-6, Cessna 185, Extra EA-330LT, DC-3, PC-21; considerably different aircraft with variations in performance, crew seating and escape equipment.

Exhibit 46  
Exhibit 49

1.4.245. The FTS and Addendum identified some QE role risks, such as “Out-Of-Control manoeuvres”. The Addendum stated that there were “no new additional residual risks in accordance with MAA Duty Holder Aviation Risk Matrix (DHARM) RtL associated with ETPS QE activity on Yak-52 when compared to routine flying”. The Addendum did not identify

<sup>96</sup> <https://www.gov.uk/aaib-reports>

<sup>97</sup> In the course of the inquiry the Panel were informed of an engine malfunction, with similar symptoms to those reported by the PIC, occurring in Norway. No fault was found with the engine upon further investigation.

<sup>98</sup> <https://www.easa.europa.eu/document-library/regulations/regulation-eu-no-3762014>.



what the residual risks of routine flying were. The Addendum acknowledged the lack of a Platform Specific Risk Register but did not go on to replicate one or its contents, for example it did not identify significant differences in instrumentation, switches and selectors between cockpits as a risk cause. The Yak-52 risk assessment did not include emergency handling in an unfamiliar cockpit, tandem cockpit, with different controls available in front and rear cockpits or the reduced forward visibility from the rear cockpit as risk causes. The risk assessment did not consider a change of risk depending on which seat the PIC occupied. The FTS included the mitigation that “*All personnel to receive safety and emergency procedures briefings prior to flight*”. The FSP had not attended the formal briefs and the accident crew’s briefing timeline was not sufficient for a thorough safety and emergency brief. The Yak-52 FTS and Addendum included the following mitigations<sup>99</sup> of risks:

- a. “*The host operator will provide a qualified CRI to act as Safety Pilot and Captain*” was a mitigation to the hazard of ‘Unfamiliar Flying Environment’ leading to ‘impact with surface and crew injury’. The FTS was clear that the “*Captain - the Safety Pilot*” was not to be allowed to relinquish authority to the ETPS participant. Exhibit 49
- b. “*An ETPS tutor will fly with the host pilot before student flying takes place.*” Given that the tutor did not assess the competence of the Safety Pilot the risk reduction of this mitigation was not clear. Exhibit 46
- c. Altitudes for performing out of control manoeuvres<sup>100</sup> are to be “*agreed with ETPS QE Tutor and Yak Safety pilot*”. This mitigation was not conformed to. Exhibit 49
- d. “*No FTE student aircraft handling – below 1000 ft.*” This mitigation was not conformed to. Exhibit 49

1.4.246. A Safety Case<sup>101</sup>, including a Risk Assessment, should have been constructed in accordance with JSP 815, and to arrive at the safety assurances required by RA1240. The safety case could have been a simple document that stated the QE training aims, the plan to deliver them through Yak-52 operations and why both the Yak-52 and sub-contracting were considered appropriate. The safety case could have noted the historic safety record of the aircraft type and put in place mitigations to prevent recurrence of the significant events and fatalities. The document could also have addressed the conduct of QE in a PTF aircraft and the implications of reduced airworthiness requirements, as compared to a COA aircraft. The wider document set would cover activity necessary to ensure that the aircraft operation was legal. The safety case would also have provided an opportunity to document the risks associated with the use of a PIC whose currency requirements varied greatly from those of ETPS flying supervisors and risks associated with operations with headsets. The safety case could probably not have been produced in its entirety by ETPS as input was required from a Yak operator to construct or contribute to a platform specific risk register for the aircraft. This risk register would have been required in addition to the QE risks captured in the ETPS FTS and addendum and those due to differences in legislation or regulation. Exhibit 51

1.4.247. Whilst the Panel was informed that the FTS and Addendum had been produced according to the good practice technique of brainstorm followed by peer review, it did not result in Risk Assessments that were notably different for aircraft types with appropriate mitigations required for the identified risks. The fact that all FW QE addendums are almost identical indicated that this methodology was not followed with sufficient rigour. In direct contrast to the FW QE addendums the Rotary Wing (RW) QE Addendums varied significantly, contained platform specific risks and therefore exhibited the traits of Risk Assessments constructed using good practice. The omission from the Risk Assessment of Exhibit 49

<sup>99</sup> Risk Mitigation. A risk mitigation has to make the probability of a risk event lower or lessen the impact of a realised risk.

<sup>100</sup> Spinning.

<sup>101</sup> The format and content of which could have been determined locally.

PIC's intention to hand over control in an emergency based on poor cockpit visibility indicated that he was not consulted as a stakeholder in the risk identification process. ETPS staff could have conducted a cockpit assessment to identify differences in instruments and controls between cockpits. This would have produced different risks for each crew composition and PIC seating position. The extent of the differences between the front and rear cockpit Field Of View (FOV) could have been assessed and any associated risks captured in the Risk Assessment (Figures 1.4.4 and 1.4.5). The Panel noted that the FOV would only have generated new risks if it were deemed to adversely affect the completion a task. A check of the logbooks for G-YAKB would have provided the opportunity to identify any airframe specific risks. As CPT Ltd had been contractually obliged to supply a legal and airworthy aircraft it was assumed that no airframe or engine specific risks existed.

Exhibit 87

1.4.248. The FTS and Addendum did not state that the PIC gave mitigation for the risks associated with emergencies; however, as Aircraft Commander the PIC would be responsible for the entire conduct of the sortie. The FTS and Addendum did not state how the presence of the PIC reduced risk or by how much. ETPS documentation and supervisors' witness testimonies were very clear that the TP students and QE PIC had clearly defined roles within QE: the ETPS participant was to conduct the planned QE; the PIC was responsible for conducting a safe flight through advice and intervention. Whilst the ATRM recognised that the FSP was unqualified, the Panel was unable to determine whether a cockpit gradient would have existed between the PIC and an ETPS tutor in an emergency situation. The Panel noted that the FTS and Addendum did not adequately address the possibility that the ETPS QE participant may have more relevant flying experience than the PIC whose currency may be unknown. This would have been covered by a thorough emergency brief which ensured that each crew member had appropriate and acceptable responsibilities in the event of an emergency.

#### QinetiQ Risk Assurance Mechanisms

1.4.249. The ETPS Technical Operating Framework (TOF) mandated the production of a risk assessment and described how Risk Assessments should be conducted. QinetiQ used a two stage risk assurance process whereby Risk Assessments, created in accordance with TOF direction, were scrutinised at Hazardous Activity Management (HAM) Level 1 and sometimes escalated to HAM Level 2. HAM Level 2 was also termed the AHASP. Which level of risk management assurance was appropriate depended on the activity undertaken. In the case of new exercises or QEs the TOF directed that this should be HAM Level 2, or AHASP. The MOD supervisory chain believed that HAM level 2 scrutiny occurred for activities every 2 years; furthermore, the MOD chain of command considered it inappropriate to sign Risk Assessments for activity being delivered by third parties as to do so would be to create an "executive document". There was no evidence that Yak-52 QE was subjected to HAM review scrutiny in the 7 years the PIC had conducted QE; Yak-52 QE was not scrutinised at AHASP.

Exhibit 133

Witness 21

1.4.250. The long standing and annually recurring QE did not qualify as new; therefore, a review of it was not triggered. As the Yak-52 was a single engine piston aircraft and the service was contracted through an ATO, it was not considered worthy of extra attention by supervisors. There was also an assumption that previous supervisors had conducted rigorous assurance prior to the first iteration of the activity. Given that the Risk Assessment that would have fed the AHASP is likely to have been the FTS Addendum published for Yak-52 QE, it is unlikely that any type specific risks or general aviation risks would have been presented and scrutinised had an AHASP taken place. Whilst the Panel was repeatedly told that QinetiQ and AWC risk management practices were well found, the Panel was faced with the evidence that not only were Risk Assessments limited to the point of not being fit for purpose but the available assurance mechanism was not used for Yak-52 QE. The MOD chain of command had determined that signing a Risk Assessment for an activity that they did not control or regulate was inappropriate; however, they took no steps to assure



themselves that the third party operator had conducted a Risk Assessment either. The platform-specific Risk Assessments for Yak-52 QE, signed or otherwise, were 'shadow'<sup>102</sup> documents which may have demonstrated due diligence had the TOF been followed. The Risk Assessment work carried out focussed on QE activity and did not assess the risks of placing ETPS personnel, on duty, into the operations of a civilian PIC where there was no AOA, ADH or protection provided by the MRP.

1.4.251. In omitting a safety case for TP flight in a third party aircraft, with no AOA or ADH, which did not benefit from the protection of the MRP and was contracted by an organisation not bound by JSP815, supervisors removed an opportunity to discharge a Duty of Care. The inadequate safety case was considered in paragraph 1.4.27 to have been an **Other Factor**. The focus on QE specific risks and lack of attention to the production and ownership by a suitable party, of type or general aviation risks with respect to Yak-52 QE, resulted in a military TP being placed in a third party Aircraft without assured mitigation of risks which was an **Other Factor**. The focus on QE specific risks and lack of attention to quantifying type or general aviation risks resulted in the risk that actually resulted in the fatal accident not being identified.

1.4.252. **Recommendations:**

- a. The Chief Test Pilot should ensure that Risk Assessments for the use of third party aircraft include an assessment of the differences between the legislation and regulations governing ETPS and the third party, to identify differences in airworthiness and pilot competence requirements.
- b. CO ETPS should put in place a process which ensures that ETPS is in receipt of a type-specific risk register for a third party aircraft prior to the hire of that platform, in order to fully understand platform risk.

**Comparison of QE at ETPS, L'école du personnel navigant d'essais et de reception (EPNER) and the United States Air Force (USAF) Test Pilot School (TPS)**

1.4.253. The Panel visited EPNER and held a VTC with the USAF TPS in order to understand how TP schools of similar standing to ETPS conduct QE. From those forums the Panel identified that:

- a. EPNER considered QE to be a highly valuable exercise. EPNER conducted QE in Preview<sup>103</sup> and Intermediate Preview exercises. EPNER did not contract for their use of third party assets; instead, it was done for them by Direction Générale de l'Armement (DGA), which was the French equivalent to Defence Equipment and Support (DE&S). In 2016 EPNER used an L-39 Albatross for one of their exercises. EPNER sent pilots and maintainers to the providing company for training. The aircraft was then dry leased to EPNER through DGA. It was delivered and operated by the now qualified and current EPNER pilots acting as PIC. The contracted company remained responsible for the airworthiness of the L-39; however, pre and post flight checks and aircraft preparation were performed by DGA ground crew trained by the providing company. EPNER prepared a Risk Assessment for use of the L-39 which focused on QE activity rather than the risks associated with general operations of the platform.

Exhibit 39

<sup>102</sup> Shadow is used when a document is not strictly necessary from a legislative or regulatory stand point but the production of it is still considered good practice. In this case the Defence activity of TP training was delivered through the PIC's Yak-52 activity. It therefore could not be the MOD's responsibility to produce and own a full Yak-52 type Risk Assessment. Those Risk Assessments that were produced were 'shadow' documents.

<sup>103</sup> Full qualitative and quantitative evaluation of an unfamiliar aircraft, in role, using all flight test assessments.



b. USAF TPS considered QE to be a highly valuable exercise. Prior to USAF TPS conducting QE, the airworthiness of the aircraft was scrutinised by a Designated Technical Authority (DTA). The DTA was a nominated person. The DTA issued a Military Flight Release (MFR) for the aircraft, post QE Review Board (QRB). The QRB considered both the airworthiness of the aircraft and the competence of the sub-contracted Safety Pilot. The DTA used the services of a FAA accredited Designated Airworthiness Representative (DAR) to provide an independent report as to a type's airworthiness and the specific tail number's airworthiness. As part of the QRB a designated QE officer attested that he had researched the sub-contracted organisation and both it and the Instructor Pilot (IP) appeared sound. The aircraft was operated under CO USAF TPS's command as a Public Aircraft but the sub-contracted IP was not under CO USAF TPS's command per se. The IP was not subjected to a skills test as he had FAA documentation; however, he was required to fly with a USAF TPS IP prior to contract award. The Risk Assessment for a QE was focussed upon the QE activity. The aircrew equipment and clothing was that supplied by the operator.

Exhibit 40

1.4.254. There were similarities and differences between the QE models at the 3 schools. The fundamental difference was that of activity ownership. Both EPNER and USAF TPS owned the exercise, ETPS did not. Both USAF TPS and ETPS used a sub-contracted Safety Pilot but neither subjected him to a Skills Test, relying upon civilian qualifications to assure themselves of his competence; conversely, EPNER trained their own pilot as PIC, which delivered a system where the supervisors were not only completely familiar with the PIC's competence but they commanded him as well. The Panel had no information on what checks were carried out by DGA to ascertain the L-39's airworthiness but maintenance oversight was ensured by EPNER personnel completing pre and post flight checks on the aircraft. The USAF TPS subjected the aircraft itself to a process whereby a Federal employee was given responsibility for issuing the MFR and the activity was considered public, not private. In accepting ownership of the activity the comparator models put in place appropriate mechanisms to deliver a Duty of Care. This was an **Observation**.

1.4.255. **Recommendation.** The Commandant AWC should conduct a review of comparator models for QE, in order to identify and adopt best practice.

## PREVIOUS REPORTS

### Historic Audits and Assurance Visits at MOD Boscombe Down

1.4.256. The AWC Standards and Evaluation (STANEVAL) conducted an Internal Quality Audit (IQA) visit to ETPS on 23 Apr 13 and an IQA re-visit on 27 Nov 13. 2 Gp Staff conducted an Air Safety Assurance Visit (ASAV) 19-21 Nov 13. As a result of issues noted at the time, Air Officer Commanding (AOC) 2 Gp suspended flying at ETPS. ETPS was returned to flying following an Extraordinary Air System Safety Working Group (ASSWG) on 29 Jan 14. At a further ASSWG AOC 2 Gp directed that the AWC provide final assurance that progress was being made to address the outstanding issues. Following this AOC 2 Gp wrote to CAS on 3 Nov 14 to "confirm that all Risks to Life (RtL) associated with the routine operation of ETPS are currently managed and mitigated such that they are Tolerable and ALARP." Between this date and the accident sortie, successive MAA audits and a further 2 Gp ASAV were completed and 3 additional ASSWGs were held. The minutes of the first of the 3 additional ASSWGs stated that the ODH was content with the situation at ETPS. Whilst it should be emphasised that the following are short extracts that may therefore lack context, the report into the 23 Apr 13 IQA visit<sup>104</sup> contained:

Exhibit 134  
Exhibit 135  
Exhibit 136

Exhibit 137

<sup>104</sup> 20130429-AWC F792-ETPS Audit 23 Apr 13-U.

**OFFICIAL SENSITIVE**

Reference	Direct Extract
Serial 4	<i>"Balance of Workload across the unit was noted to be a challenge to manage, particularly with the varying experience of Instructors and limited aircraft availability. It was also noted the resourcing levels were considered to be at the minimum required to fulfil the unit role. It was also noted the resourcing levels were considered to be at the minimum required to fulfil the unit role."</i>
Serial 25	<i>"Availability of core AC remains a high concern. In particular, Hawk, Alpha Jet and Sea King."</i>
Serial 40	<i>"No post flight in-brief to capture flight safety issues."</i>
Serial 40 contd	<i>"Crews reported a lack of preparation for sorties due to the volume of work. Closely monitored for students but not staff. Too many admin tasks which could be completed by additional Ops or Admin staff. Crews relying on experience instead of comprehensive sortie briefing and planning."</i>
Serial 42	<i>"Lack of ETPS near-miss reports, due to workload."</i>
Serial 43	<i>"Crews admit that they don't always have time to submit flight safety reports."</i>
Serial 50 (findings)	<i>"There was concern over the process of Assurance of third party providers [sic]."</i>
Serial 50 (actions)	<i>"The process for assuring third party providers to be reviewed to allow easier assurance of competence and suitability."</i>

**Table 1.4.5 Extracts from 23 Apr 13 IQA Visit to ETPS Report**

1.4.257. The AWC STANEVAL report was acknowledged by the Chief Test Pilot on 11 Jul 13, who commented that he was extremely concerned that problems previously highlighted had not been addressed by the Unit. Again emphasising that the following are short extracts the 27 Nov 13 IQA<sup>105</sup> re-visit report contained the following:

Reference	Direct Extract
Serial 7.	<i>"It still is not a common practice for crews to in-brief after a sortie, which was raised in the last audit. One staff individual questioned was unaware of the 'In-brief guide' on the Ops desk. Use of a Risk Matrix was discussed with CO ETPS."</i>
Serial 8 – referring to Serial 40 above.	<i>"Any underlining cultural issue/opinion which leads to personnel considering they are above the rules needs to be challenged by the Senior Management and stamped out immediately."</i>
Serial 8 – referring to Serial 40 above.	<i>"ACTION (ETPS-41): AWC-Fly Div should investigate the issue associated with the potential lack of sortie preparation due to workload volume amongst the staff, to understand if the associated individual's statement is based on personal perception, staff workload or an embedded culture." "ACTION (ETPS-42): CO ETPS to issue a unit order to ensure preparedness of crews for aviation activities is checked during the out-brief process; with any concerns raised directly to the</i>

<sup>105</sup> 20131201-AWC Fg Div-ETPS Audit revisit 27 Nov 13 (2) – as revised 8 Jan 14.

**OFFICIAL SENSITIVE**

	<i>XO or CO. Staff are NOT to fly unless they are appropriately prepared for the sortie."</i>
Summary	<i>"ETPS continues to be an organisation working to the maximum with the resources available (inc. gaps in key areas). In order to successfully graduate the 2013 class, what could be described as general housekeeping activities that sit at the bottom of the In-Tray are not finding their way to the top and being addressed. However, these items are now impeding the ability to satisfactorily conduct external assurance of ETPS. Although the activity at ETPS could be considered tolerable and ALARP with respect to RtL, the evidence base is potentially suspect in two key areas: Cultural Attitude (Srl 8) and Staff Aircrew documents (Srl 10)."</i>
Summary	<i>"The acceptable workload of staff, outside their primary responsibilities, should be reviewed. Where necessary, additional short-term and long-term manpower should be raised to either AWC-Fly Div and/or QQ Air Div. Workload must not be allowed to detract from the maintenance of tolerable and ALARP with respect to RtL for ETPS aviation."</i>

**Table 1.4.6 Extracts from 27 Nov 13 IQA Revisit to ETPS Report**

1.4.258. The report<sup>106</sup> into the 2 Gp ASAV was supplied to the Panel as a 24 page document. The following short extracts were taken from the wider report:

Reference	Text
Assurance Programmes – Serial 1.	<i>"ETPS require use of 'exotic aircraft' - these are leased outwith the QQ fleet and MOD allotment process. For some ac (e.g. the Hunter from Hawker Hunter Aviation) the CAE and QQ team review the platform, CAMO, Maintenance orgs, ASMP and engage on a Managers Course - to gain assurance of a new capability prior to signature of an MoU. However, CAE and dep TAA had doubts about whether the airworthiness aspects of this process were being consistently applied across all such platforms (eg Bell/Huey Helo, Grippen)."</i>
Reporting & Investigation of Occurrences – Serial 2.	<i>"There appears to be a reluctance to report all incidents within the flying community of the AWC. This may be due to the potential loss of ac for 2 days as each incident is investigated. MOD - allotted ac on trials have a FAC (Flt Auth Cert) that is invalidated if there is an Occurrence, even if that occurrence is unrelated to airworthiness and/or an observation. This means that the ac has to stop the trial and have the occurrence fully investigated and the FAC re-issued by DQAFF before the trial can be continued, which can often take 48hrs. The QQ CAE cited lack of QQ indemnity for MOD allotted ac as the cause of this issue. Anecdotally, this appears to discourage crews and eng staff from raising occurrences so that they don't disrupt trials."</i>

**Table 1.4.7 Extracts from 2 Gp ASAV Report**

<sup>106</sup> 20140119-AWC ASAV-Finalised Visit Date: 19-21 Nov 13.



1.4.259. The extracts above are short and isolated parts of wider reports. The return of ETPS to flying operations and subsequent action by AOC 2 Gp indicated that the Chain of Command was assured that measures put in place had resulted in safe operations at ETPS. These measures included adoption of the ATRM, the issuing of orders to enforce in-briefing and increasing resource. However the findings of this Service Inquiry that relate to workload, Flight Safety and reporting culture, assurance of a third party aircraft, proper conduct of in-briefs and inadequate sortie preparation were consistent with the findings of the IQAs and ASAV that led to ETPS flying operations being suspended. The Panel's inquiry was specifically focussed on Yak-52 QE, with the result that the Panel did not conduct an investigation into progress made by MOD Boscombe Down in other areas identified by the various reports as needing attention or action; however, the Panel did note that documents were available that indicated that considerable progress had been made. The minutes of ASSWGs held on 21 Oct 15 and 18 May 16 both recorded increases in reporting. The minutes did not address third party aircraft activity; however, both recorded that all RtL associated with the routine operation of AWC aircraft were at least tolerable and ALARP. The second set of minutes marked the handover of the ODH role for T&E to COS Ops, which was itself a measure put in place to improve governance. The 2 Gp ASAV report dated 19 Nov 15 assessed the AWC T&E Flying Division Air Safety Management System (ASMS) as having 'Substantial Assurance' with 3 scrutinised areas being assessed as having 'Full Assurance'. The successive MAA audits of AWC Flying Division resulted in a letter to the Chief Test Pilot acknowledging that not only were the vast majority of Corrective Action Requirements closed but that the MAA had found that MOD Boscombe Down was committed to proactively managing the ASMS. The Panel therefore opined that recurrences of previously reported shortcomings meant that the remedial action had been taken and significant, documented, Air Safety progress made but this was not effective in preventing the Yak-52 QE accident.

1.4.260. The Panel was made aware of assurance activity that was under taken prior to use by ETPS of a new aircraft, an Aviat Husky. This activity included assurance of the aircraft's documentation by QinetiQ airworthiness and a review of the Husky Commander's qualifications and currency by CO ETPS. CO ETPS requested an assessment of the Husky Commander's ability to act as Safety Pilot. The Panel concluded that such assurance activity constituted good practice.

Exhibit 149  
Witness 20  
Witness 21

1.4.261. In not ensuring that all of the shortfalls identified in previous IQA and ASAV reports were addressed on a long term basis, the MOD Boscombe Down lessons process failed, which made an accident more likely and was an **Other Factor**.

1.4.262. **Recommendations.** The Chief Test Pilot should review the MOD Boscombe Down lessons process and the actions that resulted from previous reports dating back to 2013 to ensure: That measures put in place:

- a. Address the identified issues adequately.
- b. Are still both appropriate and are being carried out.

**SUMMARY OF FACTORS**

**Causal Factor**

1.4.263. As the Panel were unable to determine with certainty whether the aircraft impacted the ground under control, in wing borne flight or having stalled, the failed Forced Landing attempt following an unexplained loss of thrust was found to be the **Causal Factor**.

**Contributory Factors**

1.4.264. The following Factors were Contributory to the accident:

- a. The PIC operated an aircraft with recurring malfunctions, which were considered by ETPS Supervisors, in retrospect, and the Panel to have reduced Flight Safety. The RPM gauge failure which required the PIC to estimate RPM settings in normal operations, with unknown consequences to the engine, made accurate RPM assessment in an emergency impossible. The Panel was of the opinion that the QE flight should not have taken place without a serviceable RPM gauge. Flight with a failed rear seat AI and gyro compasses that would not slave may have caused a distraction to the PIC, confused the PIC or increased his workload in an emergency. Whilst unlikely, it is possible that the PIC was receiving erroneous altitude from the placarded altimeter. The combination of failed gyro compasses, placarded Altimeter, failed AI and failed RPM gauges would have denied the accident crew Situational Awareness and probably introduced distraction and confusion into an emergency. The Panel concluded that flight with multiple instrumentation failures was a **Contributory Factor**.
- b. The PIC's lack of recent Practice Forced Landings (PFLs) and currency reduced his ability to carry out a successful Forced Landing and was a **Contributory Factor**.
- c. The plan to delegate landing to an unqualified pilot in a Forced Landing made an unsuccessful outcome more likely and in the opinion of the Panel was a **Contributory Factor**.
- d. Despite adequate time to plan and prepare for a Yak-52 sortie being available the opportunity was not taken. As a result the crew's preparation was inadequate and probably omitted a thorough safety brief, with the result that the FSP was unable to contribute meaningfully to fault diagnosis or emergency handling. The Panel concluded that inadequate time spent in preparation, planning and briefing was a **Contributory Factor**.
- e. The accident crew continued the glide descent to the east having realised that a Forced Landing was likely, which reduced the options of landing surfaces available to them. This was a **Contributory Factor**.
- f. The decision to attempt a landing on the farm strip was a **Contributory Factor**.

**Aggravating Factors**

1.4.265. The following Factors were Aggravating to the outcome of the accident:

- a. Whilst the Panel was unable to conclude that the FSP would have survived had he been restrained, the Panel was able to conclude that the failure of the PIC's harness straps led to significant injuries that otherwise wouldn't have occurred. The Panel determined that this was an **Aggravating Factor**.

b. It is possible that the wearing of a suitable helmet would have mitigated injuries sustained by both of the accident crew. The lack of suitable helmets was an **Aggravating Factor**.

#### **Other Factors**

1.4.266. The following Other Factors were identified during the investigation of accident:

a. The Panel concluded that the Risk Assessment contained in the FTS and Yak-52 addendum did not constitute an adequate safety case for QE, which resulted in a reduction in the employer's opportunities to both discharge and document a Duty of Care, was an **Other Factor**.

b. Yak QE was not presented at AHASP as required by written orders, which removed a significant opportunity to: scrutinise the risks associated with Yak-52, identify the lack of planned airworthiness assurance, and understand the contractual arrangements being used to provide the service. This was an **Other Factor**.

c. The FOB applied to ETPS QE participants, who were ordered to conform to the MRP. By not conforming to the MRP and in particular the reporting requirements of RA 1410, QE participants were not following the orders contained in the FOB which was an **Other Factor**.

d. Whilst letters of appointment were issued for DDH and ODH the Yak QE was not covered by either. There was no AM(MF), DDH or ODH for QE activity conducted in G-YAKB which was an **Other Factor**.

e. Although the further sub-contracting of the Yak service to the PIC was allowable within the Framework Agreement, the fact that it had been and that the ATO was therefore not directly delivering QE, was not drawn to the attention of ETPS supervisors. This removed the opportunity to scrutinise the further sub-contracted QE activity for additional risk, and was an **Other Factor**.

f. The personnel charged with delivering the procurement and project management were not Suitably Qualified and Experienced Personnel for their roles and did not consult personnel who were, removing an opportunity to review the risk associated with the activity. This was an **Other Factor**.

g. Despite the existence of a CoP for the Use of Third Party Aircraft and a published Procurement Process, personnel were unable to describe the process and did not demonstrate understanding of their roles and responsibilities. This was an **Other Factor**.

h. The MOD's process, which was reliant on QinetiQ and did not provide independent assurance of the third party aircraft's airworthiness was an **Other Factor**.

i. Permission to conduct aerial work or to carry an extra person during a demonstration flight in G-YAKB had not been granted by the CAA, which contravened Article 23 of the ANO. This was an **Other Factor**.

j. The process that QinetiQ used, which did not ensure that any SQEP received and scrutinised G-YAKB's airworthiness documents, removed an opportunity to discover that ETPS personnel were to fly in an aircraft that was operating in contravention of the ANO was an **Other Factor**.

k. The reliance on CPT Ltd to provide an airworthy aircraft that was fit for purpose



~~OFFICIAL SENSITIVE~~

without sufficient assurance, denied supervisors an opportunity to understand the maintenance regime for G-YAKB and any associated risk, was an **Other Factor**.

l. The PIC was qualified to operate the Yak-52 in accordance with civilian requirements; his recent flying hours which were much lower than the guidelines within the ETPS ATRM, were not known or risk assessed by supervisors which was an **Other Factor**.

m. The PIC's omission of a brief, on both the restricted rear cockpit visibility and his emergency handling plans, to an ETPS supervisor led to a risk going unidentified and mitigation not being in place. This was an **Other Factor**.

n. The PIC's competence as a Safety Pilot throughout the entirety of QE was never formally assessed; therefore, the assumption that he provided a mitigation of risk was unproven, invalid and was an **Other Factor**.

o. Misuse of the ATRM which masked supervisory risk was an **Other Factor**.

p. The limited training provided to QinetiQ personnel, and their supervision by the PIC, resulted in additional un-assessed risk which was an **Other Factor**.

q. On balance of evidence the Panel opined that the PIC probably omitted a thorough external check of G-YAKB before the accident sortie. This probable omission removed an important opportunity to notice indications of the impending engine malfunction; however, the Panel was unable to conclude that any such indication existed. This omission was therefore an **Other Factor**.

r. The lack of communication between QinetiQ maintenance personnel and ETPS removed an opportunity for supervisors to review the conduct of QE, which was an **Other Factor**.

s. The incomplete ETPS Yak 52 briefing material provided for QE, which was insufficient for the FSP to prepare for the sortie, was an **Other Factor**.

t. The lowering of the landing gear represents a divergence from published guidance which the panel was unable to explain. It may indicate that the FSP had not been adequately prepared for his role in a forced landing. As the aircraft impacted left wing first the position of the Landing Gear Control Lever had no effect on the outcome of the Forced Landing and the lowering of the landing gear was an **Other Factor**.

u. The omission of a check of parachute serviceability was a failure in the discharge of a Duty of Care by the PIC and FSP to themselves and was an **Other Factor**.

v. The insufficient preparation by QE aircrew, which resulted in them being unlikely to be able to abandon the aircraft in an emergency, did not affect the outcome in this instance, but was an **Other Factor**.

w. There was no policy for the immediate response to off-site aircraft crashes which led to incoherence in orders, confusion at MOD Boscombe Down and delayed the response to this accident. This was an **Other Factor**.

x. Whilst the omission in the MOD Boscombe Down ERP of an explicit requirement to respond, was incoherent with the Duty of Care, it did not affect the outcome of the accident; therefore, it was an **Other Factor**.

y. Without understanding the hazards associated with the aircraft, the emergency

services had to extract the PIC at their own risk and this was an **Other Factor**.

z. The failure of ETPS supervisory mechanisms to capture Flight Safety issues both with G-YAKB and the QE sorties was an **Other Factor**.

aa. The focus on QE specific risks and lack of attention to the production and ownership by a suitable party, of type or general aviation risks with respect to Yak-52 QE, resulted in a military TP being placed in a third party Aircraft without assured mitigation of risks which was an **Other Factor**.

ab. In not ensuring that all of the shortfalls identified in previous IQA and ASAV reports were addressed on a long term basis, the MOD Boscombe Down lessons process failed, which made an accident more likely-and-was an **Other Factor**.

## Observations

1.4.267. The Panel made the following Observations during the investigation of accident:

a. The delineation of governance between civilian registered aircraft and those on the MAR was not prominent in the MRP. This was an **Observation**.

b. RAs relevant to the operation of civilian registered aircraft existed within an otherwise inapplicable MRP in order to act as 'signposts' to the correct legislation or offer guidance in the absence of regulation. This was an **Observation**.

c. The documentation required to show that CPT Ltd was an accredited ATO was not held in one location with the result that no single person had the visibility or understanding needed to confirm the ATO's accreditation. This was an **Observation**.

d. It was unclear from the available documentation whether the insurance requirements for QE were appropriate for the activity or if the insurance arranged for the use of G-YAKB during the ETPS QE week by the PIC was valid for the activity. QinetiQ had in place insurance that covered the activity in any case. Notwithstanding this, the process that QinetiQ and MOD used did not ensure that SQEP scrutinised G-YAKB's insurance documents, with the result that they could not demonstrate that the accident sortie was insured; this was an **Observation**.

e. No permission had ever been sought from the CAA for a Yak-52 to conduct aerial work, to carry extra persons on demonstration flights, or for activity under CAP 1395 Safety Standards Acknowledgement and Consent, which indicated to the Panel that no Yak-52 QE had ever been adequately scrutinised. This was an **Observation**.

f. A PTF was unavailable to aircraft where the type qualified for a COA; therefore, all the Yak-52 activity that had been conducted in support of ETPS must have used PTF aircraft which was an **Observation**.

g. It was an **Observation** that there were other aircraft types available that could have been considered to fulfil the role of Fixed Wing (FW) QE but to identify one that was a better choice than the Yak-52 was outside the scope of the Inquiry.

h. The ETPS FOB contained an editing error which was an **Observation**.

i. In accepting ownership of the activity the comparator models [for QE] put in place appropriate mechanisms to deliver a Duty of Care. This was an **Observation**.

**PART 1.5 – RECOMMENDATIONS**

1.5.1 **Introduction.** The following recommendations are made in order to enhance Defence Air Safety:

Recommendation	Analysis Reference
<b>1.5.2 Recommendations to the Chief of the Air Staff (CAS)</b>	
1.5.2.1 The CAS should review the Senior Duty Holder (SDH) role for Qualitative Evaluation (QE) to ensure that this Defence activity falls within the Duty Holder construct.	1.4.46
<b>1.5.3 Recommendations to the Senior Duty Holder (SDH)</b>	
1.5.3.1 The SDH should re-issue letters of appointment to the Test & Evaluation Operating Duty Holder and Delivery Duty Holder, emphasising their Duty Of Care responsibility for Defence Activity within their Areas of Responsibility for which they do not Duty Hold.	1.4.46
<b>1.5.4 Recommendations to the Director MAA (D MAA)</b>	
1.5.4.1 The D MAA should review the Military Airworthiness Authority Regulatory Publications to ensure prominence in the document set of its applicability to civil registered aircraft.	1.4.32
1.5.4.2 The D MAA should review the location of Regulatory Articles pertaining to the operation of civil registered aircraft.	1.4.32
1.5.4.3 The D MAA should put in place a requirement for assurance activity to be conducted by Suitability Qualified and Experienced MOD Personnel of the documentation of third party aircraft hired by MOD, or a defence contractor, for Defence activity.	1.4.66
<p>1.5.4.4 The D MAA should review the regulations relating to hire or charter of third party aircraft in order to provide assurance that third party aircraft and their equipment are safe. The review should include the requirement for the organisation hiring the third party aircraft to confirm and record that:</p> <ul style="list-style-type: none"> <li>a. The safety and emergency equipment provided in the aircraft is appropriate and fit for purpose.</li> <li>b. The personnel flying in the aircraft will wear appropriate clothing, protective clothing and Aircrew Equipment Assemblies.</li> <li>c. An appropriate assessment of the third party aircraft has been undertaken to identify any idiosyncrasies that could affect Flight Safety.</li> </ul>	1.4.212
1.5.4.5 The D MAA should review stakeholder understanding of, and delineation between, incident response and Post-Crash Management, in order to remove confusion.	1.4.222



**OFFICIAL SENSITIVE**

1.5.4.6 The D MAA should implement a system whereby MOD airfields must receive hazard information from visiting aircraft types, for dissemination to emergency services in the event of an occurrence, prior to issuing permission for them to operate from or visit the airfield.	1.4.226
1.5.4.7 The D MAA should consider a requirement for the Commanding Officer (CO) of each MOD airfield to establish and maintain training with local civilian response organisations.	1.4.226
<b>1.5.5 Recommendation to the Commandant Air Warfare Centre (AWC)</b>	
1.5.5.1 The Commandant AWC should conduct a review of comparator models for QE, in order to identify and adopt best practice.	1.4.255
<b>1.5.6 Recommendations to the AWC's Chief Test Pilot</b>	
1.5.6.1 The Chief Test Pilot should ensure that, prior to any further QEs being conducted, all ETPS activities benefit from the production of a safety case, which demonstrates how the employer's general duties are to be delivered and assured, in order to record that he has been satisfied that the risks have been reduced to Tolerable and ALARP.	1.4.28
1.5.6.2 The Chief Test Pilot should put in place robust measures to ensure that, prior to the hiring of a third party aircraft by QinetiQ for ETPS use, he understands the contractual arrangements in order to better assess the risk to his personnel.	1.4.52
1.5.6.3 The Chief Test Pilot should ensure that the QE safety case includes a description of the Pilot in Command's (PIC) qualifications and experience and that their currency is assessed against the ETPS ATRM in order to identify risk.	1.4.104
1.5.6.4 The Chief Test Pilot should ensure that Risk Assessments for the use of third party aircraft include an assessment of the differences between legislation and regulations governing ETPS and the third party, to identify key differences in airworthiness and pilot competence requirements.	1.4.252
1.5.6.5 The Chief Test Pilot should review the MOD Boscombe Down lessons process and the actions that resulted from previous reports dating back to 2013 to ensure that measures put in place:  a. Address adequately the identified issues.  b. Are still both appropriate and are being carried out.	1.4.262
<b>1.5.7 Recommendations to QinetiQ</b>	
1.5.7.1 QinetiQ should put in place robust measures to ensure that the further sub-contracting of third party aviation is understood, appropriately approved and any necessary assurance activity takes place.	1.4.52
1.5.7.2 QinetiQ should review the process for the contracting of QE services to clearly define the responsibilities for the assurance of the service to be provided.	1.4.59
1.5.7.3 QinetiQ should ensure that a single Suitably Qualified and Experienced Person has overall accountability for QE procurement.	1.4.59

**OFFICIAL SENSITIVE**

1.5.7.4 QinetiQ should ensure that all documentation pertaining to the operation of a third party aircraft at ETPS is filed within a single repository, in order to provide a clear auditable record.	1.4.66
1.5.7.5 QinetiQ should conduct an assessment of the use of alternative aircraft types to deliver QE training aims, to determine whether a more suitable aircraft could be identified.	1.4.81
1.5.7.6 QinetiQ should review support, including associated processes necessary to deliver it, to third party aircraft operators to ensure relevant risks are captured and personnel are suitably trained.	1.4.147
1.5.7.7 QinetiQ should review the requirement to wear appropriate head and face impact protection by crews operating third party aircraft, in order to discharge a component of their Duty of Care.	1.4.207
1.5.7.8 QinetiQ should ensure that operators of ETPS hosted third party aircraft are contractually obliged to use ETPS supervisory processes, in order to allow supervisors to review their activity.	1.4.236
<b>1.5.8 Recommendations to the CO ETPS</b>	
1.5.8.1 The CO ETPS should review the Flying Order Book (FOB) to ensure that it complies with the Air Navigation Order and MAA Regulatory Publications.	1.4.39
1.5.8.2 The CO ETPS should put in place robust measures to ensure that all ETPS personnel understand reporting requirements, when operating both ETPS fleet and third party aircraft, in order to ensure that all relevant occurrences are reported.	1.4.39
1.5.8.3 In order to ensure that QE risks are mitigated the CO ETPS should: <ul style="list-style-type: none"> <li>a. Identify the QE risks to be mitigated by the Safety Pilot.</li> <li>b. Define the duties of the Safety Pilot.</li> <li>c. Put in place robust measures to provide assurance of a PIC's ability to mitigate the risks through performing the duty of the Safety Pilot.</li> </ul>	1.4.119
1.5.8.4 CO ETPS should ensure that: <ul style="list-style-type: none"> <li>a. Both staff and students, operating a new aircraft type, receive the information necessary to operate the aircraft safely, specifically highlighting any role that they may be required to perform in an emergency, in order to adequately prepare them for flight.</li> <li>b. The PIC of a QE sortie give a thorough emergency and safety brief prior to any QE sortie, which includes the responsibilities of all crew members throughout an emergency and any aircraft peculiarities that may affect them, in order to adequately prepare them for flight.</li> </ul>	1.4.133
1.5.8.5 In order for the ATRM to be used effectively as a supervisory tool, CO ETPS should: <ul style="list-style-type: none"> <li>a. Review the utility of the Matrix.</li> </ul>	1.4.138

**OFFICIAL SENSITIVE**

b. Ensure that all ETPS supervisors and students receive periodic training on the correct use of the Matrix.	
1.5.8.6 The CO ETPS should have access to aircrew publications in English for all QE aircraft types, in order to ensure crews and supervisors are adequately briefed prior to QE.	1.4.173
1.5.8.7 The CO ETPS should amend local orders, prior to the next QE, directing that all personnel practice emergency egress and abandonment before their first flight in a new aircraft type, in order to prepare them for flight.	1.4.216
1.5.8.8 The CO ETPS should amend the title of FOB E2306 Annex I, to ensure that it is consistent with the wording of FOB E2306.	1.4.236
1.5.8.9 The CO ETPS should put in place a process which ensures that ETPS is in receipt of a type-specific risk register for a third party aircraft prior to the hire of that platform, in order to fully understand platform risk.	1.4.252
<b>1.5.9 Recommendation to the Defence Fire Risk Management Organisation</b>	
1.5.9.1 The Defence Fire Risk Management Organisation should issue policy for response requirements to all MOD aircraft operating sites, in order to remove reliance on local orders.	1.4.222



**PART 1.6 – CONVENING AUTHORITY COMMENTS**

1.6.1 This tragic accident was caused by a failed forced landing attempt following an unexplained engine problem. Although the Service Inquiry (SI) Panel were unable to understand much about the flight path of the aircraft in its final stages of flight, it was concluded that it hit the ground left wing low, travelling in an easterly direction. This probably occurred after the crew elected to change their plan from conducting a forced landing into a cornfield to attempting to go for a small grass airfield strip. The cause of the engine problem currently remains unknown and may continue to be so despite an extensive technical investigation by the Air Accident Investigation Branch. It can however be concluded that engine problems are not unusual on the YAK-52 and there are numerous documented cases of such since the aircraft came into common use in the UK for recreational flying. Regardless of the issue with the engine and the failed forced landing attempt, the Panel discovered a wide range of factors that likely contributed to this accident, aggravated the outcome or are worthy of note. These issues fall into 2 main areas; firstly, the hire of the YAK-52 aircraft for this activity and secondly, the operation of the aircraft whilst at the Empire Test Pilot School (ETPS). This was a civilian registered aircraft with a civilian aircraft commander and therefore could not fall under the MOD's Duty Holder construct which is now in common use across the Armed Forces. In any event in this case, with both the hire of the aircraft and its operation, there was a Duty of Care to those involved and indeed to the Test Pilot who tragically lost his life. On the balance of evidence found by the SI Panel, it is clear that the due diligence required to ensure that this activity was conducted safely fell short of that required. I commend the SI Panel for their work where, despite the lack of clear evidence with regard to the engine problem and final moments of the flight, they have found what I consider to be the most likely sequence of events. I concur with the cause, contributory, aggravating and other factors identified by the Panel.

1.6.2 The investigation has found that the fatal accident involving G-YAKB involved a range of issues including the risk of sub-contracting, inadequate supervision, lack of risk assessment, poor reporting and not learning lessons from the past. Assumptions that all would be well by contracting an Approved Training Organisation (ATO) without due diligence checks has masked a range of unsatisfactory issues, some of which played a part in this unfortunate accident. The delivery of the Yak-52 Qualitative Evaluation (QE) by QinetiQ and the MOD used a system wherein the individual responsible for an operation delivering Defence activity (and the serviceability of the aircraft being used), was a sub-sub-contracted civilian pilot operating an aircraft which he had borrowed and which was being operated for aerial work in contravention of the Air Navigation Order (ANO). Due to this being a civilian operation there was an absence of both a military Aircraft Operating Authority (AOA) and an Air Duty Holder (ADH) and therefore no model of simplicity allowing responsibility and accountability to be identified. Despite legislation, policy, regulation, orders, and contractual agreements being in place that should collectively have guaranteed the activity was completed safely, the activity went ahead: in contravention of the ANO; in an aircraft whose airworthiness and serviceability had not been assured locally; and with a Safety Pilot whose competence and currency had not been formally assessed by QinetiQ or Defence. Whilst no single organisational factor caused the fatality, they contributed collectively to create an environment that made an accident more likely. It is worth bringing out some of these factors in more detail in 2 key areas, namely contractual hire of the Yak-52 and its operation.

1.6.3 The MOD had put in place a system, through the Long Term Partnering Agreement, which relied upon QinetiQ for deliverables such as QE but there was no independent assurance by the MOD that the QE deliverable was in place in the safe form expected. In turn QinetiQ relied upon Command Pilot Training (CPT) Limited to provide the QE service with the only assurance in place being the knowledge that CPT was an ATO and had been contractually obliged to supply an airworthy aircraft and qualified pilot. The MOD Chain of Command, outside of ETPS, was informed of the Yak-52 QE at a routine update brief the week before the activity began. The Chain of Command believed that they were relying on QinetiQ to provide a safe service to Defence which in turn QinetiQ thought they were doing by the hire of the YAK-52 and its pilot from an ATO. So in many ways, all looked well to those responsible for the governance and contractual arrangements. However, whichever way you look at this it cannot be concluded that a safe service was being provided and there were some very serious omissions including: no assurance that the Yak-52 was airworthy, no check that it was serviceable, no confirmation that the Safety Pilot-In-Command was competent and that the aircraft was being used in a manner that was compliant with the ANO which it turned out not to be. All in all, there was not enough documentation or checks of sufficient rigour to say that this aircraft and pilot were fit for the purpose of the hire; it is my judgement that they were not. Indeed, QinetiQ was not in receipt of sufficient documentation to show that G-YAKB was legally able to carry additional persons on Demonstration Flights. QinetiQ also relied upon their Framework Agreement and Purchase Order with a Civil Aviation Authority (CAA) accredited ATO to ensure that the aircraft was correctly certificated. QinetiQ assumed that dealing with an ATO, and having in place contractual obligations on the ATO, provided a level of assurance that the service met all CAA requirements which was perhaps not unreasonable. QinetiQ's own assurance activity to confirm that the aircraft was correctly certificated consisted of taking delivery of various documents, which were not then subjected to sufficient scrutiny by trained personnel.

1.6.4 As ETPS was not a Yak-52 operator, a local risk register for the aircraft had not been produced. Neither was a risk register demanded from the sub-contracted ATO or the further sub-contracted Safety Pilot who had borrowed the aircraft for the purpose of the QE. The Yak-52's safety record, which included 11 fatalities in the UK up to the accident sortie, was not considered by QinetiQ or the Chain of Command. This placed the Front Seat Pilot in an aircraft with numerous historic occurrences, and no risk mitigation in place except the presence of a Safety Pilot who was familiar to supervisors but whose competence had not been formally assessed and whose duties were undefined. The requirements to achieve the qualifications held by the Safety Pilot were not documented and the implications of the significant differences between civilian and military qualification and currency requirements were not considered. Assurance activity in the form of a check of the Safety Pilot's logbook was also not conducted. Overall, no stakeholder grasped the reality of a sub-sub-contractor operating a borrowed aeroplane or the implications that this introduced either in the context of unassessed risk or the Chain of Command's understanding of what was actually being delivered. In short, stakeholders assumed all was well but did not check the detail with qualified persons. In this case, personnel charged with managing this procurement at MOD Boscombe Down were not Suitably Qualified Experienced Personnel (SQEP) for their roles and not sufficiently familiar with the governance in place. Finally, they did not consult airworthiness personnel who were in a position to scrutinise key documents. This led

directly to ETPS personnel flying in an aircraft that was unfit for purpose and operating in contravention of the ANO.

1.6.5 The Panel was mindful of the minimum equipment list for an aircraft operating in Visual Flight Rules; however, it is highly questionable whether G-YAKB was fit for the intended flight as it launched with failed RPM gauges in the front and rear cockpits, failed gyro compasses, an inoperative altimeter and a failed rear cockpit attitude indicator. These failures would have denied the accident crew critical information during the emergency and likely caused distraction and confusion. In particular, it would have been very difficult to diagnose an engine problem without RPM gauges in either cockpit and the reliance on a small magnetic standby compass during a major emergency could not be considered wise. Despite being serviced the aircraft had not had an engine overhaul in 24 years as it had never reached the required 750 hours limit for overhaul which was legal but perhaps questionable. The accident crew wore parachutes which would have appeared out of date for re-packing to anyone who inspected them, the Front Seat Pilot (fatality) wore no helmet and the aircraft cockpit had rudder pedal straps whose interaction with MOD aircrew clothing and Aircrew Equipment Assembly had not been assessed. The seat harness straps in G-YAKB were visibly faded, were found to be significantly weakened and components of the straps failed during the accident. It was not possible to state that the accident would have been survivable had the Front Seat Pilot, who was thrown clear, been restrained because the available space in the front cockpit was compressed during the crash sequence by the aircraft engine block; however, had he worn a helmet and visor his head injuries would have likely been far less. QinetiQ relied upon the sub-sub-contracted operator to ensure that the aircraft remained serviceable throughout QE week. Assurance activity that could have reviewed the aircraft serviceability was in place in the form of aircrew in and out-briefs but this unfortunately did not work to a point where the QE was questioned. The Safety Pilot did not tell ETPS supervisors about any of the unservicabilities on the aircraft on arrival or its deterioration during the week, neither were they reported by other QE participants. QinetiQ's procedure, which relied upon honest and punctual input from ETPS students, the Safety Pilot, and personnel involved with aircraft operations failed to identify that G-YAKB had multiple faults for the fatal QE flight on 8 Jul 16. The lack of reporting both from QinetiQ maintenance personnel and ETPS QE participants removed an opportunity for supervisors to review the conduct of the QE.

1.6.6 The Safety Pilot was inadequately prepared for the QE in that his recent flying hours were significantly lower than those expected and demanded from an ETPS supervisor. Despite another pilot recording the Safety Pilot flying with him, the Safety Pilot himself had only logged one flying hour in a Yak-52 in the time between the 2015 QE and the 2016 QE delivery flight. It is reasonably believed that his lack of recent Practice Forced Landings reduced his ability to carry out a successful Forced Landing on the day. QinetiQ relied upon CAA and European Aviation Safety Agency (EASA) qualifications to ensure that the Safety Pilot was competent but there was no CAA/EASA qualification that translated directly to ETPS QE. QinetiQ and MOD Supervisors were assured of the Safety Pilot's competence by receipt of his licences from CPT Ltd and by a familiarisation sortie but he was not formally assessed during this flight. Finally, QinetiQ's procedure failed to request documentation that might have contributed to an assessment of competence, for example his flying logbook.



1.6.7 The organisational aspects of this accident demonstrated that the lessons identified by previous internal audits and formal staff assurance reports had not been learnt. The impact of the staff's high work load, the lack of assurance of third party aircraft, the limited preparation and the absence of in-briefs were all previously identified inadequacies. Whilst the SI Panel was informed that the workload of both tutors and students on ETPS was high, no discernible reason was given for this. The Panel was unable to identify a time constraint on the accident crew or an operational imperative driving the work pattern at ETPS. The accident crew did not take advantage of the adequate planning and preparation time that was available; furthermore, the QE sortie briefs given to other participants had not included a thorough safety or emergency brief. The accident crew spent approximately 15 minutes planning, preparing and briefing for the sortie when other participants' preparation time totalled approximately 2 hours. Of note, QE participants who benefitted from significantly more briefing and preparation time than the Front Seat Pilot were not confident that they could abandon the aircraft in an emergency. The compressed preparation, planning and briefing time probably led to the situation where the Front Seat Pilot was unsure of his role and actions in an emergency, limiting his ability to contribute to the diagnosis of malfunctions. Potential evidence of this exists in that the undercarriage of the YAK-52 was selected down immediately prior to the crash, a divergence from the YAK-52 Forced Landing procedures which state that an actual forced landing should be done wheels up. The down selection of the gear was either done intentionally by the Front Seat Pilot through a lack of knowledge or he was directed to do so by the Safety Pilot. Whilst the Panel was advised not to rely upon the Safety Pilot's recollection of events, the Safety Pilot reported that the Front Seat Pilot was unable to complete an emergency action in the manual operation of the fuel pump at the correct tempo. These errors are likely logical outcomes of the short period spent preparing for the sortie. The Safety Pilot's plan to relinquish control of the aircraft in a Forced Landing was not briefed to supervisors nor probably the Front Seat Pilot himself and the SI Panel was unable to conclude who, if anyone, was controlling the aircraft when it struck the ground.

1.6.8 Multiple aircraft and agencies responded to the crash. The Defence policy for response to off-site aircraft crashes was that local orders were to be followed but local orders did not in turn clearly direct a response. The cascade from the Joint Service Publication leaflet, through the Military Regulatory Publication – Regulatory Article, to the Defence Aerodrome Manual and Emergency Response Plan all lacked clear direction. This led to confusion at MOD Boscombe Down and delayed the response to the accident. The emergency services had to extract the Safety Pilot at their own risk, as hazard information for the aircraft was not held by the MOD aerodrome from where it was operating. In addition, local civilian emergency services who had primacy for the response were unfamiliar with the capabilities of the MOD Boscombe Down based responders.

1.6.9 In summary, we will likely never know the cause of the engine problem that led to the failed Forced Landing attempt. However, the Panel has identified a range of issues that are frankly surprising and some either contributed to the accident or made the outcome worse. Many of the people involved in the contract hire had made the assumption that all was well but the gaps made by the sub-sub-contracting were not found as the reasonably expected due diligence was not undertaken. Regardless of the inadequacies of the contract hire, what perhaps is even more surprising is that this QE operation continued at ETPS for a week

~~OFFICIAL SENSITIVE~~

without either the aircrew, engineers or supervision picking up on what was clearly an unprofessional and deteriorating situation. We need to ask ourselves why this could happen under the gaze of the world's premier Test Pilot School.

**DG DSA**

1.6 - 5