



Rail Accident Investigation Branch

# Rail Accident Investigation: Interim Report

**Collision near London Waterloo station,  
15 August 2017**

Report IR2/2017  
December 2017

*Note: This interim report contains information obtained from the Rail Accident Investigation Branch's (RAIB) initial examination of the available evidence. Some of the information contained in this report may be refined or changed as the investigation progresses.*

*The purpose of a RAIB investigation is to improve safety by preventing future railway and tramway accidents or by mitigating their consequences. It is not the purpose of such an investigation to establish blame or liability. Accordingly, it is inappropriate that RAIB reports should be used to assign fault or blame, or determine liability, since neither the investigation nor the reporting process has been undertaken for that purpose.*

# Collision near London Waterloo station, 15 August 2017

## Summary

- 1 At around 05:42 hrs on Tuesday 15 August 2017, a passenger train leaving London Waterloo station and travelling at about 13 mph (21 km/h), collided with a stationary engineering train. There were no injuries, but both trains were damaged and there was serious disruption to train services.
- 2 The passenger train was the 05:40 hrs South West Trains service from Waterloo to Guildford and comprised 10 coaches, a combination of class 455 and class 456 electric multiple units. The engineering train was standing on a line adjacent to the intended route of the passenger train.
- 3 The collision occurred because a set of *points*<sup>1</sup> was not in the correct position and directed the passenger train away from its intended route. When the train passed over them, the points were in this position because of a temporary modification to the points control system, which also caused the train driver and signaller to receive indications that the points were correctly set.



Figure 1: Passenger and engineering trains after the collision

<sup>1</sup> This report contains technical terms (shown in italics the first time they appear in the report). These are explained in the appendix.

## The RAIB's role and the context of this interim report

- 4 The RAIB is responsible for conducting independent investigations into railway and tramway accidents in the UK. The purpose of its investigations is to improve safety by establishing the causes of accidents and making recommendations to reduce the likelihood of similar occurrences in the future or to mitigate their consequences.
- 5 The RAIB is not a prosecuting body; its investigations are focused solely on safety improvement and do not apportion blame or liability. The police and the Office of Rail and Road deal with contraventions of the law. None of their statutory duties are changed by the RAIB investigation.
- 6 The RAIB's investigation is running independently of those of the Office of Rail and Road, and the industry. However, all investigating agencies, and the industry, are co-operating fully with each other.
- 7 This interim report provides some key information including the RAIB's findings from its initial investigation. It builds upon the information already provided on the RAIB's website<sup>2</sup>. A final report will be published on completion of the investigation. All RAIB investigation reports are available on the RAIB website.

## Background information

### Parties involved

- 8 Network Rail owns and operates the infrastructure involved and employ the signaller. It was also part of the alliance of companies that were undertaking the upgrading works.
- 9 Southwest Trains operated the train and employed the driver (the franchise is now operated by South Western Railway).
- 10 The Wessex Capacity Alliance, formed of a number of infrastructure companies and Network Rail, was undertaking a programme of works on the lines leading into London Waterloo station.
- 11 OSL Global UK Limited was contracted by Colas Rail, part of the Wessex Capacity Alliance to undertake the signal works testing for the Waterloo upgrade.

### Accident location

- 12 Waterloo station is the London terminus of the south western main line with routes to Portsmouth, Weymouth via Southampton, Exeter via Salisbury and various commuter lines around west and south west London. The platforms are numbered 1 to 24 from south to north.
- 13 Departures from platform 11 are controlled by signal W21 and its associated route indicator. Both the signal and route indicator are repeated at low level (a co-acting signal) so that train drivers can easily see them from close up (figures 2 and 5).
- 14 Points 1524 A and 1524 B form one half of a *double slip*. The other half is formed by points 1525 A and 1525 B. Points 1524 C connect the double slip to the up main fast line (see figures 2 and 3). All of 1524 and 1525 point ends were operated by an electro-hydraulic mechanism known as a clamp-lock.

---

<sup>2</sup> <https://www.gov.uk/government/news/collision-near-london-waterloo-station-15-august-2017>.

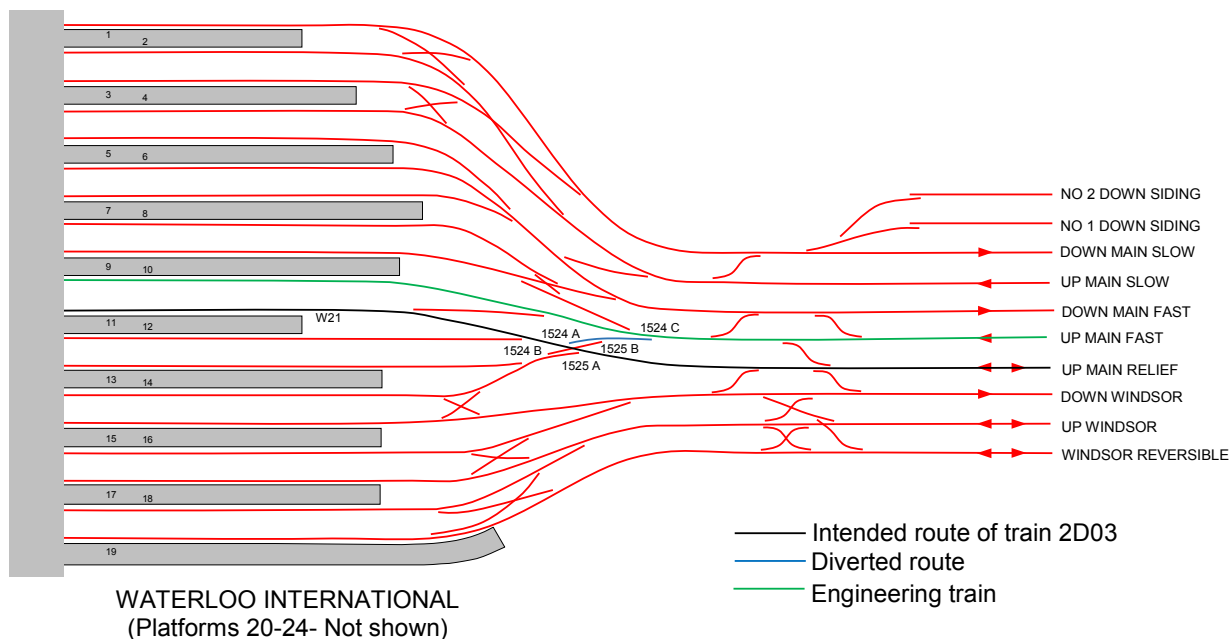

Figure 2: Schematic layout of tracks (platforms 1 to 19) at London Waterloo Station

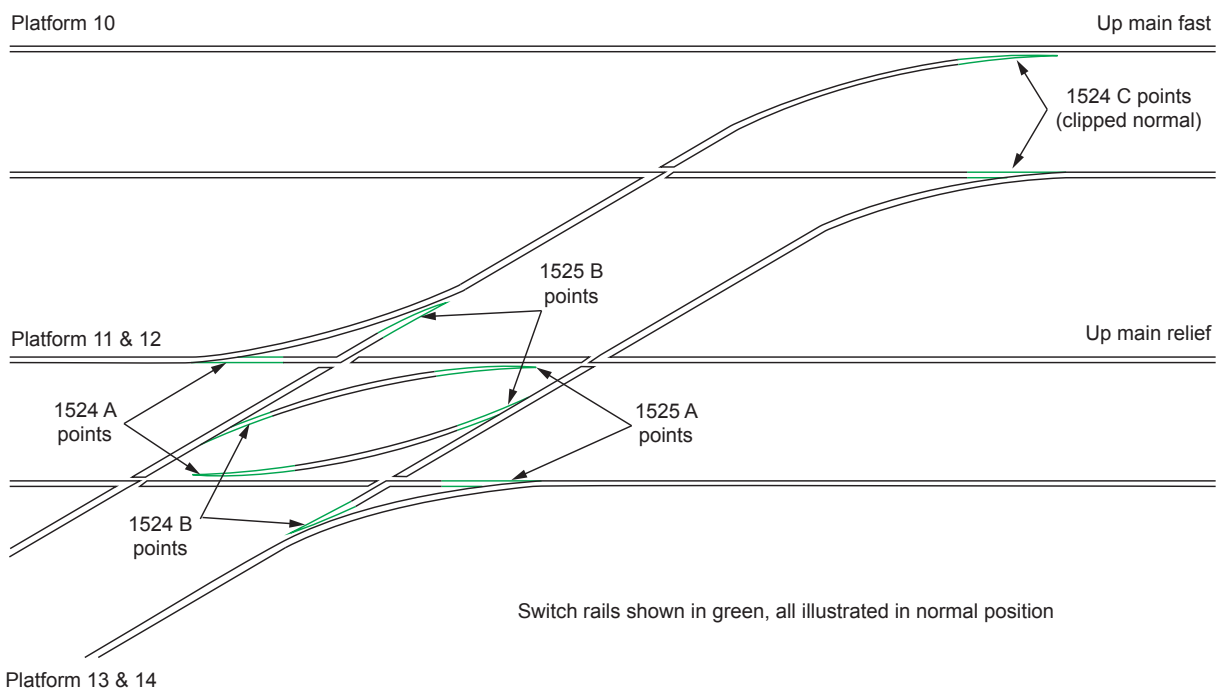

Figure 3: Detailed layout of accident location

15 Routes from platforms 11 and 12 via 1524 points would lead to the up main relief line with 1524 points *normal* and the up main fast line with 1524 points *reverse*.

External circumstances

16 At the time of the accident it was getting light (sunrise was at 05:46 hrs) and the weather was clear and dry.

### The upgrading works

- 17 The Wessex Capacity Alliance was undertaking a programme of upgrade works on the routes into Waterloo. The Alliance was awarded the contract in 2015 and is due to finish the works in late 2018. The works included extensions to platforms 1 to 4 and associated changes to trackwork and signalling.
- 18 Many of the work activities were undertaken during a partial closure of Waterloo station from 5 to 28 August 2017.
- 19 The engineering train was positioned on the line into platform 10 to act as a safety and visual barrier between the lines that were being relaid during the closure and the operational lines serving platforms 11 to 24.

### The accident

- 20 The collision occurred at 05:42 hrs as train 2D03, the 05:40 hrs Waterloo to Guildford service, was leaving platform 11. When the front of the train was around 65 metres from the platform end, and while travelling at 15 mph (24 km/h), it was directed to the left on 1524 A points and collided with the engineering train. Images from forward facing CCTV equipment shows that both *switch rails* of 1524 A points were lying midway between their normal and reverse positions (figure 4).
- 21 The driver had noticed that the points were not correctly set and applied the train's brakes around 3 seconds before the collision. This reduced the train's speed from 15 mph (24 km/h) to 13 mph (21 km/h) prior to the impact. The train came to a stop with the left hand wheels of the leading coach above the left-hand rail.



Figure 4: View from the train's forward facing CCTV of 1524 A points lying midway between normal (left switch rail closed) and reverse (right switch rail closed) (see appendix)

- 22 No one was injured, although there was some damage to the leading coach and to the engineering train. The accident caused severe disruption.
- 23 The train was directed to the left because the points which should have been set in the normal position were incorrectly lying in an intermediate state, close to the reverse position. The signalling system incorrectly indicated that the points were correctly set and safe, which meant that neither the signaller nor the driver were made aware of a problem.



Figure 5: View from the train's forward facing CCTV of the green signal and 'UR' (Up Main Relief) route indication, duplicated at high and low levels, at the departure end of platform 11

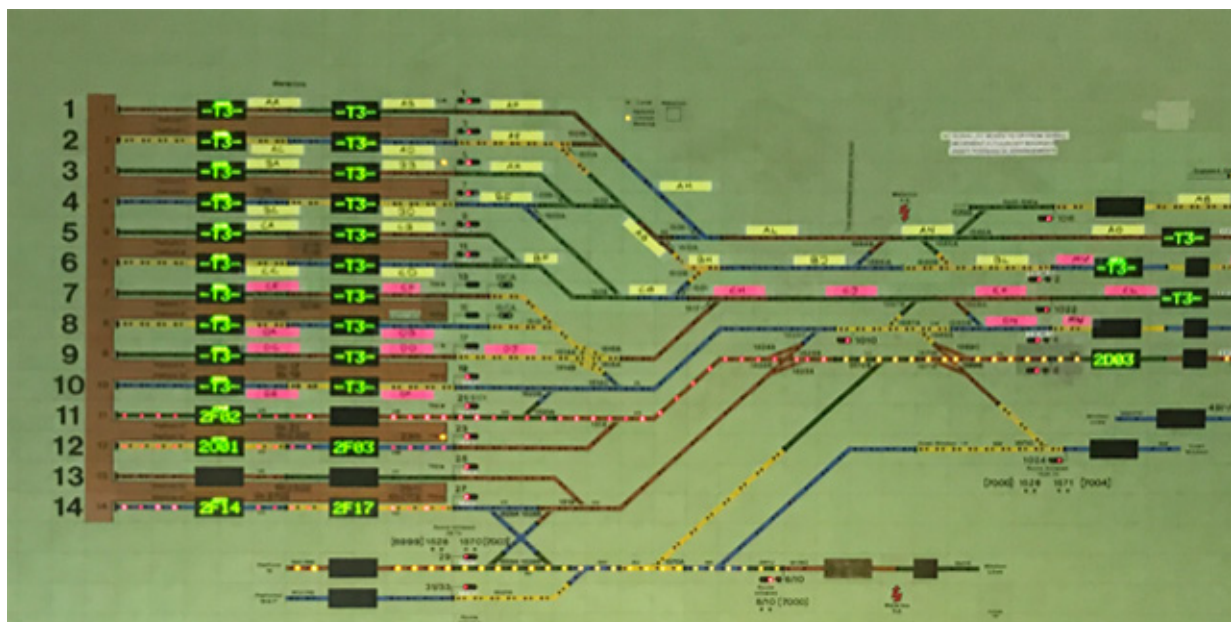

Figure 6: Signaller's view: the section of Wimbledon ASC panel showing the route out of platform 11, set for and occupied by train 2D03 (note that the engineering train was not displayed to the signaller, because indications on that part of the panel had been disconnected as the area was a worksite, not an operational railway).

## Initial findings

### Sequence of events

- 24 The moving rails on railway points are known as switch rails, the positions of which are detected by point detectors. On clamp lock points these are electrical contactors adjacent to each switch tip. Contacts associated with both the left and right hand rails must detect that the points are in the correct position before the detection *relay* can register. In the case of points, such as 1524 at Waterloo, with several ends, detectors at all ends must be reporting that the points are correctly set before a signal will clear for a train to pass over them. The wiring diagrams that follow are simplified to show only one detector and relay where there are actually normal and reverse position detection circuits in the installation.
- 25 Before the works began, the point detection for 1524 points had the detector for each end wired in series, meaning that all three ends must be in the same position before any current was returned to the detection relays. This current was then used to power the relays for 1524 A and B and 1524 C detection (figure 7a). Further circuitry required both detection relays to be correctly energised before trains were permitted to approach 1524 points.

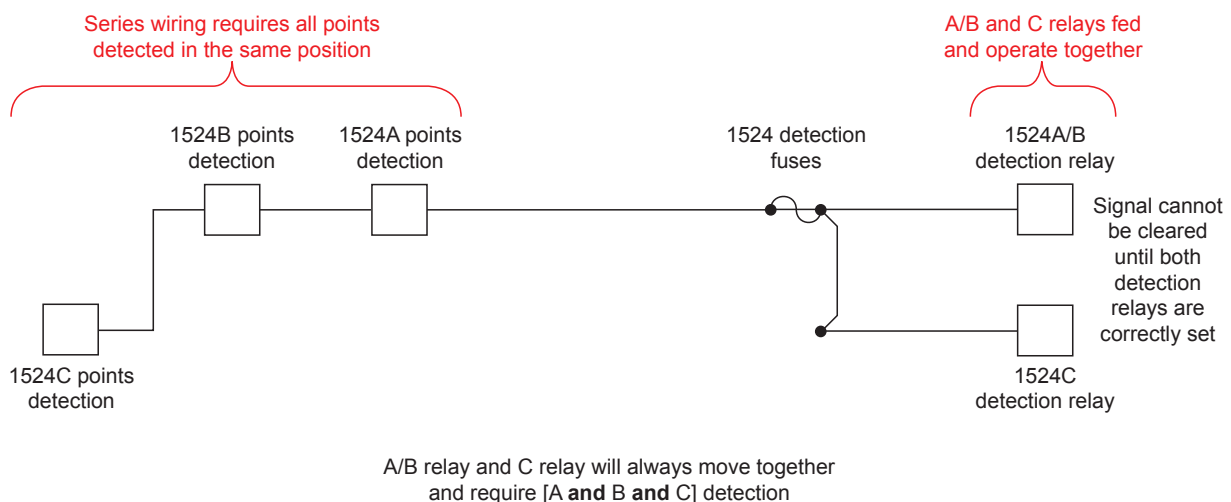

Figure 7a: 1524 points detection wiring as installed before work began

- 26 The signalling system had been fitted with a test desk, in advance of the August 2017 partial closure, to enable signalling functions to be simulated, so aiding testing during the works. This had been designed based on the signalling system wiring which existed in June 2016 and was installed and tested in August and September 2016. The test desk was only permitted to be used while trains were prevented from operating, and so the signalling testers had a process for removing fuses from the operational circuits and inserting *links* into the test desk circuits to use the test desk. This process was reversed before the line was restored to normal working (figure 7b).



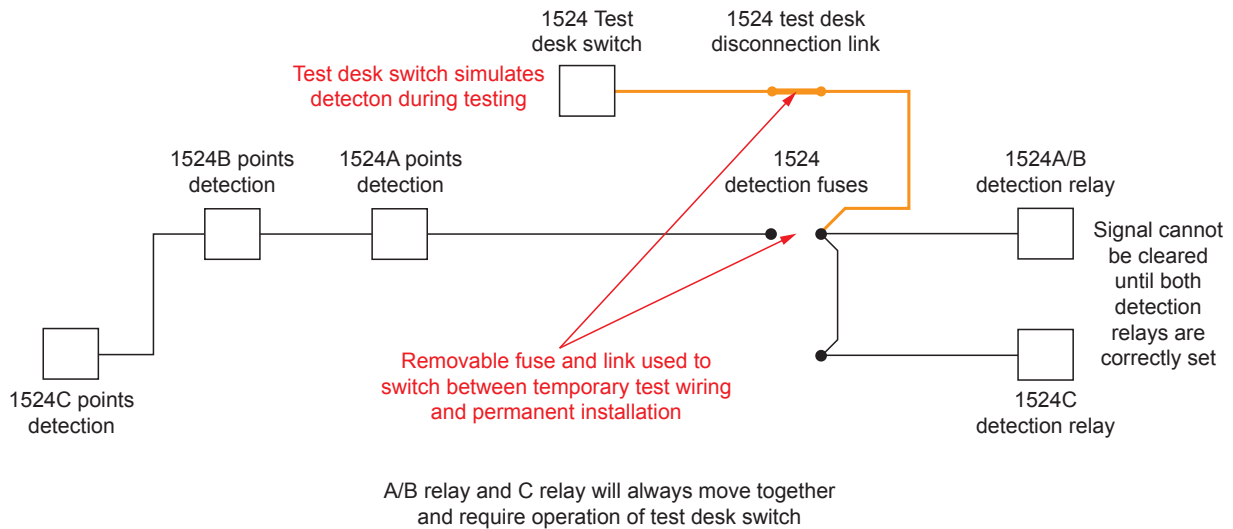

Figure 7b: 1524 test desk wiring as designed (shown when test desk in use)

27 To make room for the new station layout, it was necessary to relocate a track-side signalling location case, W14, which contained part of the wiring for the detection circuits for 1524 points. As part of the relocation, the design of the point detection wiring was modified to bring it in line with typical modern design. The detection for 1524 A and B points was now being returned to the relays on a separate circuit to the detection for 1524 C (figure 7c). As in paragraph 24, further circuitry required both detection relays to be correctly energised before trains were permitted to approach 1524 points, so the safety of the signalling system was unaffected by this change.

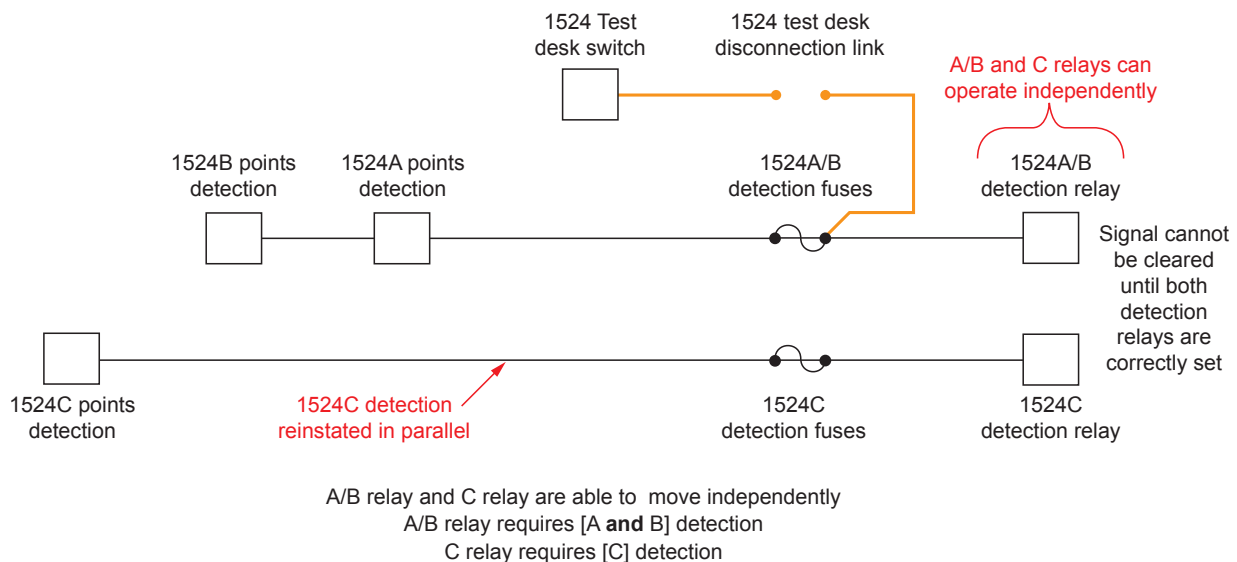

Figure 7c: change of circuit design: after location W14 abolished (shown with test desk 'switched' out)

28 The modification to the wiring of the point detection circuits in location case W14 and Waterloo relay room during the partial closure of Waterloo Station meant that the test desk no longer simulated the detection of 1524 points correctly because 1524 C points were no longer included in in the circuit that the test desk switch was connected to (figure 7d).

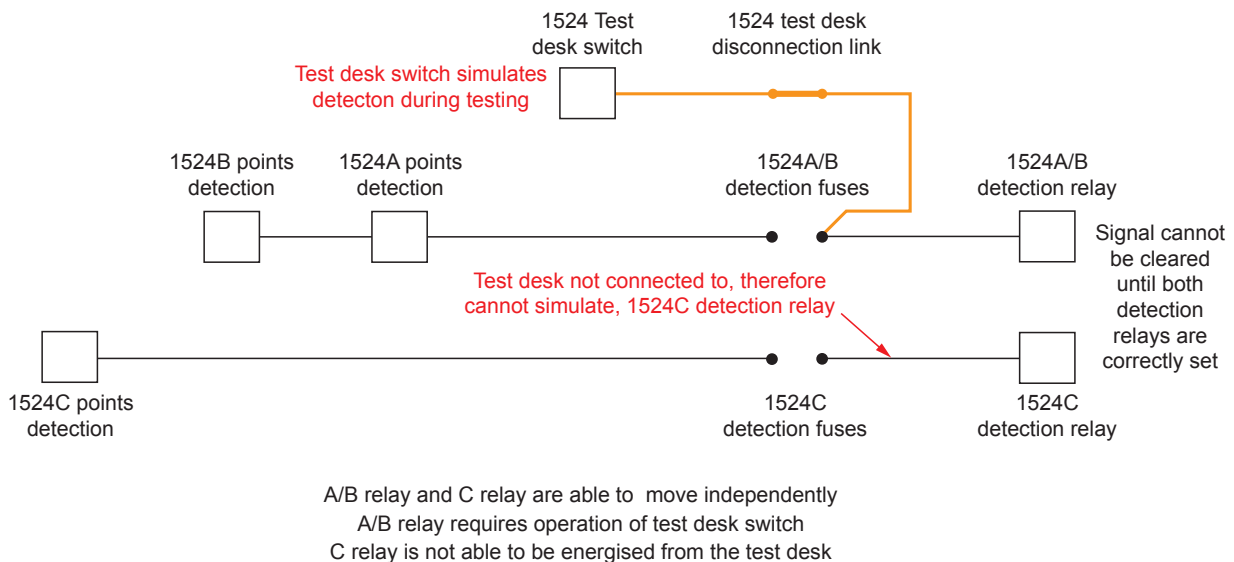

Figure 7d: 1524 points in test mode after location W14 abolished

29 On the weekend of 12/13 August 2017, while trains had been stopped from running on the lines leading to 1524 points, a temporary wiring modification was made in the relay room in an attempt to restore the correct operation of the 1524 points test desk switch. This modification (figure 7e) was not reviewed by a signalling designer and was incorrectly left in place when the railway was returned to operation on the morning of 14 August. Contrary to Network Rail standards, no test log or modification record has been found, and the RAIB is still investigating the exact circumstances surrounding the installation of this temporary wiring modification. Leaving this modification in place when the railway was returned to operation had the effect of changing the logic between the point detection and the relays so that if either 1524 A and B or 1524 C point ends were detected on the ground, the system reported all ends detected.

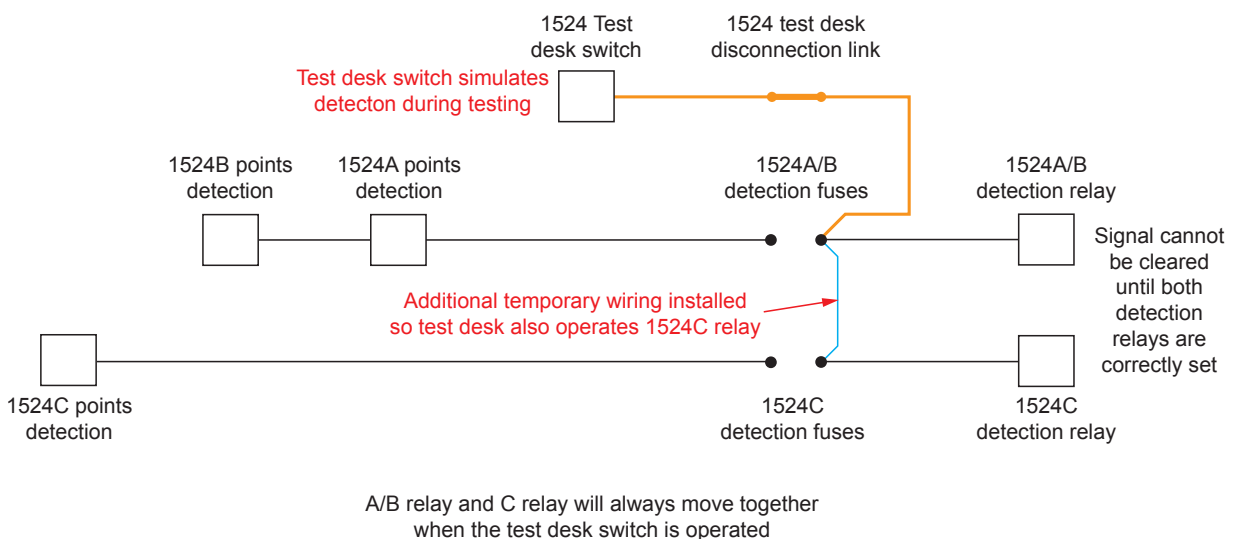

Figure 7e: 1524 points at time of testing, temporary wires added so that the test desk operated both sets of relays

- 30 During the night of 14/15 August, signalling testers at Wimbledon Area Signalling Centre (ASC) were checking signalling routes into Waterloo station. One of these routes required 1524 points to be called reverse (commanded to reverse position). The tester believed that all ends of 1524 points were secured in the normal position<sup>3</sup>, so did not expect them to move.
- 31 When 1524 points were called reverse, the A and B ends were free to move to the reverse position. The C end remained in the normal position as this end had been clipped in the normal position. As a result of the temporary wiring in the relay room (figure 7f), once A and B reached the reverse position all three ends of the points would have registered as reverse in the signalling system.

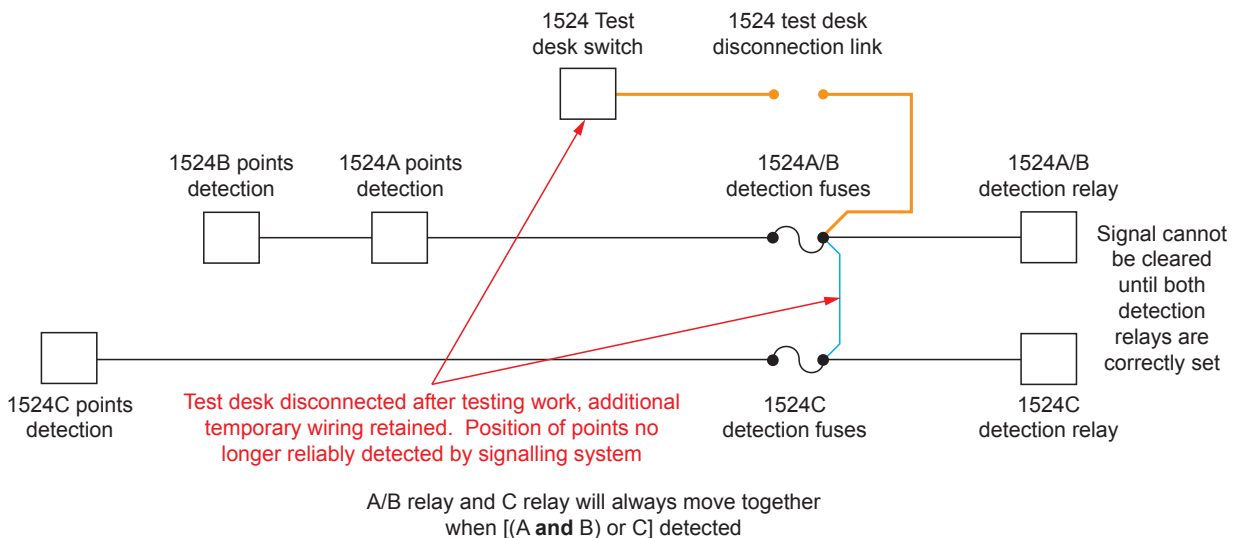

Figure 7f: 1524 points detection at time of derailment

- 32 When the route was cancelled and the testers returned the points switch on Wimbledon ASC signaller's panel to the normal position, points 1524 A and 1524 B began to move to the normal position. When the points had been moving for around one second and reverse detection was lost, normal detection was gained via the correctly detected C end and the temporary wiring. As soon as this normal detection was obtained, the power to the point motors was cut, resulting in the points remaining unlocked<sup>4</sup> and at, or close to, the reverse position.

<sup>3</sup> The tester was testing the route setting functions of the signalling system. The signalling interlocking allows a route to be called if the points are available to be called in the signalling logic. The points being immobilised by clips would not prevent this, although it would prevent the signals on the route giving proceed indications.

<sup>4</sup> Clamp lock points have a mechanical locking mechanism which holds the switch rail in place. This lock is released in the first part of the hydraulic actuator's movement and reengaged at the end of its travel.

- 33 At 05:17 hrs train 2F02 from Guildford to Waterloo passed over 1524 A points in the trailing direction as it travelled into platform 11, pushing the switch blades partially towards the normal position. The signalling system did not indicate this to the signaller because the point detection was maintained normal by the C end and the temporary wiring. Without this indication, the signaller had no means of detecting that this 'run through' had occurred. At 05:35 hrs train 2O02 from Wimbledon also ran through the points on its way into platform 12; again, this was not detected by the signalling system. The passage of the trains through the points was not sufficient to place the points fully into the normal position. Even if the points had been moved fully to the normal position, the clamp lock mechanism would have needed to be powered to engage the locks.
- 34 The signaller set the route for train 2D03 to depart and proceed along the up main relief line. Having received notification from the guard that the train was ready to depart, the driver of 2D03 checked he had the correct route indication and proceed signal before starting his train. The train reached 1524 points and was directed towards the engineering train and the collision occurred. One of the consequences was that the train damaged 1525 points which caused an Out Of Correspondence<sup>5</sup> indication to flash on the Wimbledon signaller's panel.
- 35 The signaller at Wimbledon was then contacted by the train driver to report the accident.

#### Securing of points

- 36 The test plan for the blockade required that, among others, points 1524 A, B and C be secured in their normal positions.
- 37 Points 1524 C (under the barrier train) were secured normal, however the A and B ends were not.
- 38 The tester (paragraph 30) believed that the points were secured as detailed in the test plan. The lack of point securing alone should not have resulted in a dangerous situation, as without the erroneous temporary circuitry, the signalling system would have correctly detected the position of 1524 A points. However, had they been secured, the accident would not have occurred.
- 39 The RAIB continues to investigate the circumstances which led to the points not being secured as intended.

#### **RAIB's future action in the investigation**

- 40 The RAIB's ongoing investigation is considering:
- the design processes intended to ensure safe design of modifications made during the engineering work, the processes for identifying errors and the reasons why these were ineffective on this occasion;
  - the extent of testing which could/should have identified the unsafe control system modification and the reason(s) why the error was not found by testing;
  - why the A and B ends of 1524 points were not secured as planned;

---

<sup>5</sup> A flashing light next to the point switch on the signaller's panel which indicates that the points are not in the position which the signalling system requires them to be in. It is therefore not safe to run trains over point whose Out Of Correspondence light is flashing.

- relevant aspects of the training, competence assessment, working hours and fatigue management for designers, checkers, installers and testers;
  - relevant underlying management factors; and
  - lessons learnt from previous similar accidents and incidents.
- 41 The RAIB's investigation report will include recommendations to reduce the likelihood and/or consequence of similar events occurring in the future.

**Rail Accident Investigation Branch**

**Date: 20 December 2017**

## Appendix - Glossary of terms

All definitions marked with an asterisk, thus (\*), have been taken from Ellis's British Railway Engineering Encyclopaedia © Iain Ellis. [www.iainellis.com](http://www.iainellis.com).

|             |   |
|-------------|---|
| Double Slip | A design of crossover with four sets of switch rails, which allows two railway lines to cross, with routes from each approach to each exit.                   |
| Link        | A removable component in an electrical circuit, designed to form a disconnection point.   |
| Normal      | The default position of a set of points, usually directing trains along the most often used route.*   |
| Points      | An assembly of switches and crossings, designed to divert trains from one line to another.*   |
| Relay       | An electromechanical device that utilises an electromagnet to operate electrical switches which determine the connection or disconnection of other circuits.* |
| Reverse     | The alternative position to normal of a set of points, usually directing trains along the less used route.*   |
| Switch rail | The moveable section of rail within a set of points, two switch rails move together to direct trains.   |

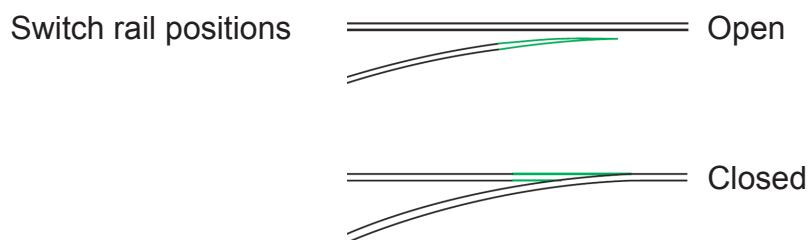

---

This interim report is published by the Rail Accident Investigation Branch, Department for Transport.

© Crown copyright 2017

Any enquiries about this publication should be sent to:

|             |   |
|-------------|---|
| RAIB        | Telephone: 01332 253300   |
| The Wharf   | Fax: 01332 253301   |
| Stores Road | Email: <a href="mailto:enquiries@raib.gov.uk">enquiries@raib.gov.uk</a> |
| Derby UK    | Website: <a href="http://www.gov.uk/raib">www.gov.uk/raib</a>           |
| DE21 4BA    |   |